

QLARITY[®]-BASED TERMINAL HARDWARE MANUAL

**BEIJER ELECTRONICS
2212 South West Temple #50
Salt Lake City, Utah 84115-2648
USA**

**Phone 801-466-8770
Fax 801-466-8792**

**Email info@bejerelectronicsinc.com
Web <http://www.bejerelectronicsinc.com>**

Copyright © 2011 Beijer Electronics. Printed in the USA. All rights reserved. No part of this publication may be reproduced, in any form or by any means without prior written permission from Beijer Electronics.

Qlarity and QTERM are registered trademarks of Beijer Electronics.

Microsoft, Windows, Windows NT, Windows 2000, Windows XP, Windows Vista, Windows 7, ActiveSync, and their respective logos are registered trademarks of Microsoft Corporation in the United States and other countries.

All other brand and product names used in this manual are trademarks or registered trademarks of their respective companies.

Manual updated 23 March 2011.

FCC Compliance Statement

This device complies with part 15 of the FCC Rules. Operation is subject to the following two conditions: (1) This device may not cause harmful interference, and (2) this device must accept any interference received, including interference that may cause undesired operation.

This equipment has been tested and found to comply with the limits for a Class A digital device, pursuant to part 15 of the FCC Rules. These limits are designed to provide reasonable protection against harmful interference when the equipment is operated in a commercial environment. This equipment generates, uses, and can radiate radio frequency energy and, if not installed and used in accordance with the instruction manual, may cause harmful interference to radio communications. Operation of this equipment in a residential area is likely to cause harmful interference, in which case the user will be required to correct the interference at his own expense. Any modification to this device (including any changes to the recommended antenna configuration) that are not expressly approved by Beijer Electronics could void the user's authority to operate this device.

Additionally, these devices may contain the following FCC module-certified components depending on product configuration: MQ4WUG2K7C (QTERM-G58) or MXFC910226 (QTERM-G55).

CONTENTS

CHAPTER 1. QTERM-G70 TERMINAL	1
1.1 Product Description	1
1.1.1 Specifications	2
1.2 Supported Interfaces	4
1.2.1 Serial Ports	4
1.2.2 Optional Ethernet Port	5
1.2.3 Optional PS/2 Keyboard Interface	5
1.2.4 Optional 5 Volt Power Supply on Secondary Serial Port	5
1.2.5 Optional Dual and Quad EIA-232 Serial Port Card	6
1.2.6 Optional Power-over-Ethernet Module	6
1.2.6.1 Power Requirements	6
1.2.6.2 Pinouts	7
1.3 Terminal Components	7
1.3.1 Touch Screen	7
1.3.2 Keyboard	8
1.3.3 Keypad	8
1.3.4 Speaker	9
1.3.5 Real-Time Clock	9
1.3.6 System Memory	9
1.3.7 Watchdog Timer	10
1.4 Installing to NEMA-4 Specifications	10
1.4.1 Cutout for Panel Mount Configuration	10
1.4.2 Installing the Panel Mount Terminal	11
1.4.3 Cutout for Drywall Mount Configuration	13
1.4.4 Installing the Drywall Mount Terminal	13
1.4.4.1 Removing the Drywall Mount Terminal	14
1.4.5 Applying Power	14
1.5 Powering On the Terminal for the First Time	15
CHAPTER 2. QTERM-G75 TERMINAL	17
2.1 Product Description	17
2.1.1 Specifications	18
2.2 Supported Interfaces	20
2.2.1 Serial Ports	20
2.2.2 Optional Ethernet Port	21
2.2.3 Optional PS/2 Keyboard Interface	21
2.2.4 Optional 5 Volt Power Supply on Secondary Serial Port	21
2.2.5 Optional Dual and Quad EIA-232 Serial Port Card	22
2.2.6 Optional Power-over-Ethernet Module	22
2.3 Terminal Components	22
2.3.1 Touch Screen	22
2.3.2 Keyboard	23
2.3.3 Keypad	23
2.3.4 Speaker	24

2.3.5 Real-Time Clock	25
2.3.6 System Memory	25
2.3.7 Watchdog Timer	25
2.4 Installing to NEMA-4 Specifications	25
2.4.1 Cutting Out the Panel	26
2.4.2 Installing the Terminal	27
2.4.3 Applying Power	28
2.4.4 Powering On the Terminal for the First Time	29
CHAPTER 3. QTERM-G55 TERMINAL	31
3.1 Product Description	31
3.1.1 Specifications	32
3.2 Supported Interfaces	34
3.2.1 Handheld Connector Interface	34
3.2.1.1 Power Interface	35
3.2.1.2 Primary Serial Interface	35
3.2.1.3 Secondary Serial Interface or Network Interface	35
3.2.1.4 E-stop Option	35
3.2.1.4.1 Power Interface with E-stop Option	36
3.2.1.4.2 Serial or Network Interface with E-stop Option	36
3.2.1.4.3 E-stop Switch Interface	36
3.2.1.5 Accessory Cable Wire Color Code	36
3.2.1.6 Integral Cable	37
3.2.1.6.1 Power Interface with Integral Cable	38
3.2.1.6.2 Primary Serial Interface with Integral Cable	38
3.2.1.6.3 Secondary Serial Interface or Network Interface with Integral Cable	38
3.2.1.7 E-stop Option with Integral Cable	38
3.2.1.7.1 Power Interface with E-stop Option and Integral Cable	39
3.2.1.7.2 Serial or Network Interface with E-stop Option and Integral Cable	39
3.2.1.7.3 E-stop Switch Interface with Integral Cable	39
3.2.1.8 Integral Cable Wire Color Code	39
3.2.2 Panel-mount Connector Interface	40
3.2.2.1 Optional Ethernet Port (Panel-mount)	41
3.2.3 Optional Power-over-Ethernet Module	41
3.2.3.1 Power Requirements	42
3.2.3.2 Pinouts (Panel-mount)	42
3.3 Terminal Components	43
3.3.1 Display	43
3.3.2 Keypad	44
3.3.3 Speaker	44
3.3.4 Real-Time Clock	45
3.3.5 System Memory	45
3.4 Installing to NEMA-4 Specifications	45
3.4.1 Cutout for Panel Mount Configuration	46
3.4.2 Installing the Panel Mount Terminal	46
3.4.3 Applying Power	47
3.4.4 Powering On the Terminal for the First Time	47

CHAPTER 4. QTERM-G56 TERMINAL	49
4.1 Product Description	49
4.1.1 Specifications	50
4.2 Supported Interfaces	52
4.2.1 Connector Interface	52
4.2.1.1 Power and USB Device Interfaces	53
4.2.1.2 Serial Multiprotocol Port Interface	53
4.2.1.3 Additional Serial Interface (without Ethernet option)	53
4.2.1.4 Network Interface (with Ethernet option)	53
4.2.1.5 Accessory Cable Wire Color Code and Demo Cable Pinout	54
4.2.2 Integral Cable	54
4.2.2.1 Power and USB Device Interfaces with Integral Cable	55
4.2.2.2 Serial Interface with Integral Cable	55
4.2.2.3 Additional Serial Interface with Integral Cable (without Ethernet option)	55
4.2.2.4 Network Interface with Integral Cable (with Ethernet option)	56
4.2.2.5 E-stop Option with Integral Cable	56
4.2.2.6 Power and USB Device Interfaces with E-stop Option and Integral Cable	56
4.2.2.7 Serial Interface with E-Stop Option and Integral Cable (without Ethernet option)	56
4.2.2.8 Additional Serial Interface with E-Stop Option and Integral Cable (without Ethernet option)	57
4.2.2.9 Network Interface with E-Stop Option and Integral Cable (with Ethernet option)	57
4.2.2.10 Serial Interface with E-stop Option and Integral Cable (with Ethernet option)	57
4.2.2.11 E-stop Switch Interface with Integral Cable	57
4.2.2.12 Integral Cable Wire Color Code	58
4.3 Terminal Components	58
4.3.1 Display	58
4.3.2 Touch Screen	59
4.3.3 Keypad	59
4.3.4 Speaker	59
4.3.5 Real-Time Clock	60
4.3.6 System Memory	60
4.3.7 Applying Power	61
4.4 Powering On the Terminal for the First Time	61
4.4.1 Accessing The Internal Mass Storage Via USB	62
CHAPTER 5. QTERM-G58 TERMINAL	63
5.1 Product Description	63
5.1.1 Specifications	64
5.2 Supported Interfaces	66
5.2.1 Connector Interface	66
5.2.1.1 Power and USB Device Interfaces	67
5.2.1.2 Serial Multiprotocol Port Interface	67
5.2.1.3 Accessory Cable Wire Color Code and Demo Cable Pinout	67
5.3 Terminal Components	68

5.3.1 Display	68
5.3.2 Touch Screen	68
5.3.3 Keypad	69
5.3.4 Speaker	69
5.3.5 Real-Time Clock	69
5.3.6 System Memory	70
5.3.7 Applying Power	70
5.4 Powering On the Terminal for the First Time	71
5.4.1 Powering and Charging the Battery Powered QTERM-G58	71
5.4.2 Accessing The Internal Mass Storage Via USB	72
CHAPTER 6. QTERM-Z60 TERMINAL	73
6.1 Product Description	73
6.1.1 Specifications	73
6.2 Supported Interfaces	75
6.2.1 Serial Ports	75
6.2.2 Five Volt Power Supply Output	76
6.2.3 External Reset Input	77
6.3 Terminal Components	77
6.3.1 Touch Screen	77
6.3.2 Speaker	77
6.3.3 System Memory	78
6.4 Installing to NEMA-4 Specifications	78
6.4.1 Cutting Out the Panel	78
6.4.2 Installing the Terminal	79
6.4.3 Applying Power	80
6.4.4 Powering On the Terminal for the First Time	81
CHAPTER 7. QTERM-G72 TERMINAL	83
7.1 Product Description	83
7.1.1 Specifications	84
7.2 Supported Interfaces	86
7.2.1 Primary Serial Port (Multiprotocol Port Interface)	86
7.2.2 Secondary Serial Port	87
7.2.3 Ethernet Port	88
7.2.4 USB 2.0 Port	89
7.2.5 Terminal Strip for Power Input	89
7.3 Terminal Components	90
7.3.1 Touch Screen	90
7.3.2 Speaker	90
7.3.3 Real-Time Clock	90
7.3.4 System Memory	90
7.3.5 Watchdog Timer	91
7.4 Installing to NEMA-4X Specifications	91
7.4.1 Cutting Out for Panel Mount	91
7.4.2 Installing the Terminal	92
7.4.3 Applying Power	94

7.4.4 Powering On the Terminal for the First Time	95
CHAPTER 8. POWER ON SETUP	97
8.1 Using a Touch Screen	97
8.2 Using a Keypad	100
8.3 Using a Keyboard	101
8.4 Power On Setup Functions	102
8.4.1 Flash Memory	103
8.4.1.1 App Mode	103
8.4.1.2 Erase FFS	105
8.4.2 Display	105
8.4.2.1 Contrast	105
8.4.2.2 Backlight	105
8.4.2.3 Orient	106
8.4.2.4 Touch	106
8.4.2.5 DCache	106
8.4.3 Calibration	107
8.4.3.1 Temp	107
8.4.3.2 Date	107
8.4.3.3 Time	108
8.4.3.4 Touchscreen	108
8.4.4 Network	109
8.4.5 Wireless	110
8.4.6 Security	110
8.4.7 COM1 and Any Additional Installed Serial Ports	111
8.4.8 Keypad	113
8.4.8.1 Keyclick	113
8.4.8.2 Key Repeat	113
8.4.8.3 Rpt Delay	114
8.4.8.4 Rpt Rate	114
8.4.8.5 AutoShift	114
8.4.8.6 AutoPower	115
8.4.8.7 Keypad Backlight	115
8.4.9 Keyboard	115
8.4.9.1 Rpt Delay	115
8.4.9.2 Rpt Rate	116
8.4.10 Sound	116
8.4.10.1 Volume	116
8.4.10.2 Note Amplitude	116
8.4.11 Feedback	116
8.4.11.1 Serial	117
8.4.11.2 Video	117
8.4.11.3 USB	117
8.4.11.4 UDP	117
8.4.11.5 Addr	118
8.4.11.6 Port Number	118
8.4.12 Miscellaneous	118

8.4.12.1 Information	118
8.4.12.2 Use Password.....	119
8.4.12.3 Change Password.....	119
8.4.13 Diagnostics	119
8.4.13.1 Keypad Key	120
8.4.13.2 Keybrd Key	120
8.4.13.3 Transmit Key	120
8.4.13.4 SDRAM Test	120
8.4.14 Done	121
8.4.14.1 Save and Exit	121
8.4.14.2 Exit w/o Save	121
8.5 Touch Screen Calibration.....	121

FIGURES

Figure 1, QTERM-G70 Serial Connector	4
Figure 2, QTERM-G70 Ethernet Port Pinouts	5
Figure 3, QTERM-G70 PS/2 Keyboard Interface Pinouts	5
Figure 4, QTERM-G70 Standard Key Legend.	7
Figure 5, QTERM-G70 Landscape Cutout	11
Figure 6, QTERM-G70 Front Panel Mount	12
Figure 7, QTERM-G70 Back Panel Mount	12
Figure 8, QTERM-G70 Drywall Mount.	13
Figure 9, QTERM-G75 Serial Connector	20
Figure 10, QTERM-G75 Ethernet Port Pinouts	21
Figure 11, QTERM-G75 PS/2 Keyboard Interface Pinouts	21
Figure 12, QTERM-G75 Standard Key Legend.	23
Figure 13, QTERM-G75 Landscape Cutout	26
Figure 14, QTERM-G75 Front Panel Mount	27
Figure 15, QTERM-G75 Back Panel Mount	28
Figure 16, QTERM-G55 Handheld Connector	34
Figure 17, QTERM-G55 Integral Cable Connector.	37
Figure 18, QTERM-G55 Panel-mount Serial Connector	40
Figure 19, QTERM-G55 Ethernet Port Pinouts	41
Figure 20, QTERM-G55 Display	43
Figure 21, QTERM-G55 Panel Mount Cutout	46
Figure 22, QTERM-G56 Handheld Connector	52
Figure 23, QTERM-G56 Integral Cable Connector.	55
Figure 24, QTERM-G56 Display	59
Figure 25, QTERM-G58 Handheld Connector	66
Figure 26, QTERM-G58 Display	68
Figure 27, QTERM-Z60 Serial Connector	76
Figure 28, QTERM-Z60 Display	77
Figure 29, QTERM-Z60 Landscape Cutout	79
Figure 30, QTERM-Z60 Front Panel Mount	80
Figure 31, QTERM-Z60 Back Panel Mount	80
Figure 32, QTERM-G72 Supported Interfaces	86
Figure 33, QTERM-G72 Serial Connector	87
Figure 34, QTERM-G72 Serial Connector	87
Figure 35, QTERM-G72 Ethernet Port	88
Figure 36, QTERM-G72 USB Port	89

Figures

Figure 37, QTERM-G72 3-Pin Terminal Strip89

Figure 38, QTERM-G72 Landscape Cutout92

Figure 39, QTERM-G72 Front Panel Mount93

Figure 40, QTERM-G72 Panel Mounting94

Figure 41, Touch Screen Landscape Orientation98

Figure 42, Touch Screen Portrait Orientation98

1.1 Product Description

The QTERM®-G70 terminal is an Ethernet-enabled graphic terminal with object-based programming. It features a robust list of industrial grade hardware features and options.

The QTERM-G70 features a QVGA, 320x240 pixel, LCD display available in STN color (256 colors) or optional grayscale (16 shades) or active-matrix TFT (256 colors). It uses a cold-cathode fluorescent backlight (CCFL). The CCFL provides high contrast and easy readability and is replaceable. On STN and grayscale units, the contrast is software-controlled and compensated for temperature.

The analog-resistive touch screen covers the full viewable area of the display as well as the pre-labeled legend underlay on each side of the display.

The QTERM-G70 comes equipped with one serial port using an EIA-232, EIA-422, or EIA-485 interface. A second serial port, an Ethernet port, and a PS/2 keyboard port are available as options.

Possible input devices include the touch screen and attachable keyboard (with an optional PS/2 connector). Custom configurations of the QTERM-G70 can also support an external keypad, a dual EIA-232 full serial port card or a quad EIA-232 full serial port card (contact Beijer Electronics for details). A speaker, which has programmable pitch and duration, comes standard, as does a battery-backed real-time clock. Other options include: an audio decoder for playing audio wave files, a hardware watchdog timer, and a 5 V/100 mA output from the auxiliary serial port to power external devices.

The QTERM-G70 terminal stores the firmware and the user application in a compressed format in flash memory and then transfers them to RAM memory when the terminal is powered on. The terminal is equipped with four megabytes of flash memory and sixteen megabytes of RAM memory.

The outer legend can be customized with your logo/name or graphics. The inner legend underlay around the display can be customized with your touch keys and graphics.

The QTERM-G70 terminal requires a DC power source in a range of 8 to 26 VDC. This power is supplied via the main DB9 serial connector. Other options for supplying power to the QTERM-G70 are PoE (Power-over-Ethernet) and five volts from a well-regulated power supply via the main DB9 serial connector. Please contact Beijer Electronics for more information about this option. The five volt power supply input option is only available on terminals with the TFT display option.

1.1.1 Specifications

The following tables contain the technical specifications for the QTERM-G70.

TERMINAL DISPLAY	
Color (standard)	STN 256 colors
Grayscale (optional)	FSTN 16 shades of gray
Active Matrix (optional)	TFT 256 colors
Enhanced TFT (optional)	Enhanced TFT 256 colors
Pixels	320 x 240
Dot Pitch	0.36 mm
Contrast	Software-controlled, temperature compensated (N/A on TFT units)
Lighting	Cold-cathode fluorescent, brightness is software-controllable
Backlight Brightness	Color 200 nits typical Grayscale 195 nits typical TFT 470 nits typical Enhanced TFT 600 nits typical
TOUCH SCREEN	
Analog-resistive operation	
Transparent touch area over viewable display	
Labeled touch underlay area on each side of display	
INTERFACE	
Standard	EIA-232 serial port with hardware or software handshaking
Baud rates	600 – 115,200 bps
Flow control	None XonXoff (software) RTS/CTS (hardware)
Data formats	7 or 8 data bits 1 or 2 stop bits Even, odd, or no parity (PC Tools support only 8 data bits)
Connector	DB9f (2 with optional second serial port) 8-pin modular (RJ45) with Ethernet option PS/2 keyboard connector (optional)
Options	Primary serial port configurable as EIA-232, EIA-422, or EIA-485 Secondary serial port available (EIA-232, EIA-422, or EIA-485) Ethernet 10/100Base-T with support for TCP/IP networking PS/2 keyboard port Additional dual or quad full EIA-232 serial port cards available

MEMORY	
Standard	4 Mbytes flash and 16 Mbytes SDRAM
SPEAKER	
Standard	Software programmable pitch and duration
Optional	Audio (.wav) decoder
REAL-TIME CLOCK	
Independent processor-based, real-time clock equipped with a battery backup	
PHYSICAL	
Configuration	Panel-mount
Housing	Glass-filled polyester, UL 94V-0 flame rating, accommodates panels from 0 to 7 mm thick with standard screws
Size	215 x 161 x 50 mm
Weight	1.16 kg
Processor	200 MHz Intel® XScale™ core platform
ENVIRONMENTAL	
Sealing	NEMA-4 front panel
Temperature	Operating: -10 to 60 °C, Storage: -20 to 70 °C
Humidity	0 to 95%, non-condensing
Vibration	5 to 5000 Hz, 4 g RMS
Shock	20 g, 3 ms, any axis
POWER	
8 to 26 VDC (See section 1.4.5 for current consumption)	
PoE (Power-over-Ethernet)	
Well-regulated 5V supply (contact Beijer Electronics)	
SOFTWARE	
Programming language	Qlarity® (object-based)
Design environment	Qlarity Foundry (Windows®)
Command line compiler	Qlarity (Win32 or Linux®)
CUSTOMIZING	
Outer legend	Customize with logo/name or graphics
Inner legend	Customize with touch keys and graphics
CERTIFICATION	
FCC Part 15, Class A CE Certification	

1.2 Supported Interfaces

1.2.1 Serial Ports

The QTERM-G70 comes standard with one serial port with DB9f connector. The serial port interface can be EIA-232, EIA-422, or EIA-485. A second serial port is available as an option, as well as two or four additional full EIA-232 serial ports are also optional.

NOTE  *The primary and auxiliary serial ports are wired as Data Communications Equipment (DCE).*

EIA-232	with proper cables and grounding the terminal can communicate up to five meters at a top speed of 115,200 bps
EIA-422	permits operation at distances up to 2,000 meters
EIA-485	permits multiple terminals to be connected in a multi-drop chain

Figure 1 shows the serial connector's orientation.

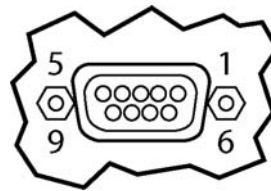

Figure 1
QTERM-G70 Serial Connector

The following table shows the pinouts for each type of serial interface.

Pin	232	422	485
1	—	Tx-	RTx-
2	Tx	Tx+	RTx+
3	Rx	Rx+	—
4	—	—	—
5	Ground	Ground	Ground
6	—	Rx-	—
7	CTS (in)		—
8	RTS (out)		—
9	Power	Power	Power

Power is supplied to the terminal through pin 9 and ground is supplied through pin 5 of the primary serial port connector.

1.2.2 Optional Ethernet Port

The optional Ethernet port has a standard 10/100Base-T interface with an 8-pin (RJ-45) modular jack connector and uses TCP/IP protocol. The connector orientation and pinout table are shown in Figure 2.

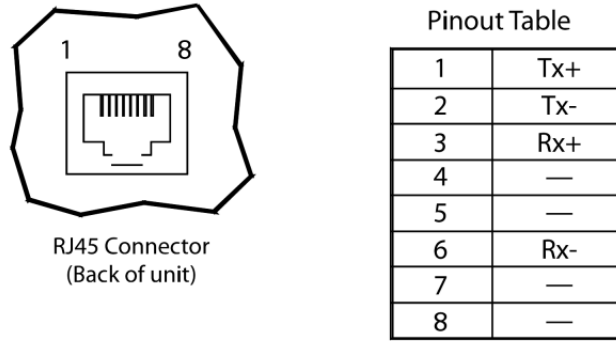

Figure 2
QTERM-G70 Ethernet Port Pinouts

1.2.3 Optional PS/2 Keyboard Interface

The optional PS/2 port can be used to connect a standard PS/2 keyboard to the QTERM-G70 terminal. The connector orientation and pinout table are shown in Figure 3.

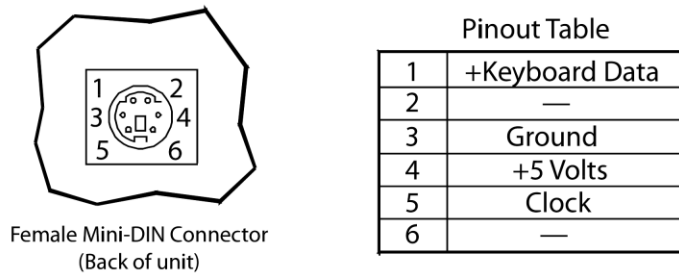

Figure 3
QTERM-G70 PS/2 Keyboard Interface Pinouts

NOTE PS/2 keyboard interface is not available in the terminals with the PoE option.

1.2.4 Optional 5 Volt Power Supply on Secondary Serial Port

The secondary serial port interface (if included) can optionally be configured to provide a 5 volt DC power supply. The supply can provide up to 100 mA current to a serial peripheral device (such as a barcode reader) connected to COM2. The 5 volt supply is provided on pin 9 and returns to ground on pin 5.

1.2.5 Optional Dual and Quad EIA-232 Serial Port Card

An additional two or four EIA-232 serial ports can be added to the QTERM-G70. **These serial ports have all necessary signals for EIA-232 serial communications and are wired as Data Terminal Equipment (DTE).**

The additional serial port option will add approximately 10 mA to the total current draw of the terminal plus 15 mA per connected serial cable.

The following table shows the pinouts for the additional serial port option.

Additional EIA-232 Serial Port Pinouts	
1	DCD (in)
2	Rx (in)
3	Tx (out)
4	DTR (out)
5	GND
6	DSR (in)
7	RTS (out)
8	CTS (in)
9	RI (in)

1.2.6 Optional Power-over-Ethernet Module

The optional Power-over-Ethernet module allows the user to provide power and communications to the QTERM-G70. The power can be provided from an IEEE 802.3af compliant hub or switch as well as from a standard power supply.

1.2.6.1 Power Requirements

The optimal power supplied to the QTERM-G70 through the PoE port is 48 VDC, although the unit will operate with a power input as low as 36 VDC, or as high as 57 VDC (see IEEE 802.3af specification). The power required to operate the terminal without any additional options is listed below.

Current Consumption	
Terminal	48 VDC
G70 STN Idle	120 mA
G70 TFT Idle	190 mA
Active Add	+15 mA

1.2.6.2 Pinouts

In accordance with the PoE standard (IEEE 802.3af), the PoE port is insensitive to polarity of the power supply and can receive power in either mode A (superimposed on the transmit and receive twisted pair conductors) or mode B (using the additional twisted pair conductors). This yields four possible ways to apply power to the PoE port as shown in the following table. The table also shows the conductor assignment for the transmit and receive lines as reference.

Port Pin Assignment		
Conductor	Mode A	Mode B
1	Tx+/V+	Tx+
2	Tx-/V+	Tx-
3	Rx+/V-	Rx+
4		V+
5		V+
6	Rx-/V-	Rx-
7		V-
8		V-

1.3 Terminal Components

1.3.1 Touch Screen

The QTERM-G70 touch screen provides user input through any number of touch keys located on or around the display. The standard key legend shown in Figure 4 provides areas for five soft keys down each side of the display. A custom legend underlay can be ordered to personalize the terminal for your application.

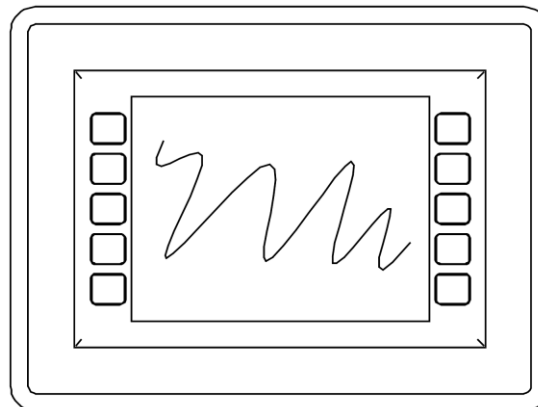

Figure 4
QTERM-G70 Standard Key Legend

Touch keys can also be defined in your user applications at any location on or around the display. Touch keys may be any size.

1.3.2 Keyboard

Using the optional PS/2 port, a standard PC keyboard may be used in addition to, or in place of, the touch screen. Power On Setup, the terminal setup utility, recognizes both touch keys and keyboard keys.

1.3.3 Keypad

The QTERM-G70 terminal can optionally include electronics for attaching an external keypad with up to 8 columns by 8 rows and up to 6 keypad LEDs. Contact Beijer Electronics for more information.

The keypad option will add 10 mA to the total current draw of the terminal plus the current driven out the LED outputs pins. The LED outputs are five-volt open-collector signals with a 1000 Ohm series resistor. This results in an approximate maximum output current drive of 5 mA on those pins. There are two connectors on the keypad module to facilitate connecting different sized keypads. The pinouts for those connectors are shown in the following tables.

Connector J1 - 0.1 Inch Pitch 16-pin Single-row Connector			
1	GND	9	Row 5
2	LED 1	10	Row 6
3	Row 1	11	Col 1
4	Row 2	12	Col 2
5	Row 3	13	Col 3
6	Row 4	14	Col 4
7	GND	15	Col 5
8	LED 2	16	Col 6

Connector J2 - 0.1 Inch Pitch 24-pin Dual-row Connector			
1	Row 1	13	Col 1
2	5 V or 3.3 V	14	LED 4
3	Row 2	15	Col 2
4	GND	16	LED 3
5	Row 3	17	Col 3
6	LED 6	18	LED 2
7	Row 4	19	Col 4
8	LED 5	20	LED 1

Connector J2 - 0.1 Inch Pitch 24-pin Dual-row Connector			
9	Row 5	21	Col 5
10	Row 8	22	Col 6
11	Row 6	23	Col 8
12	Row 7	24	Col 7

1.3.4 Speaker

A speaker is built into the QTERM-G70 terminal and faces to the back of the unit. Audio can be linked to events or actions (e.g., screen press, timer, etc.). Pitch and duration of a sound are controlled by API functions called from the user application. Refer to “Controlling the Speaker” section in the *Qlarity-based Terminal Programmer's Reference Manual*.

Optionally, an audio (.wav) decoder can be added to the QTERM-G70 to allow the speaker to play audio files. The audio decoder supports wave files meeting the following criteria:

- Sample rate of 8 kHz, 11.025 kHz, 16 kHz or 22.050 kHz
- Resolution of 8 or 16 bits per sample.

The audio decoder circuit amplifies the signal to 0.5 W rms at the speaker.

1.3.5 Real-Time Clock

The QTERM-G70 terminal is equipped with a battery-backed, real-time clock. The real-time clock can be used to time/date stamp messages or for timed polling and program execution.

WARNING



There may be danger of leakage if the battery is incorrectly replaced, creating a potential health hazard. Replace the battery only with the same (CR1220) or equivalent type as recommended by the manufacturer. Dispose of used batteries according to the manufacturer's instructions.

1.3.6 System Memory

The QTERM-G70 terminal stores the firmware and user applications in a compressed format in flash memory and then transfers them to RAM memory when the terminal is powered on. Four megabytes of flash memory and sixteen megabytes of RAM memory are standard.

For information on using resources efficiently to conserve memory when creating a user application, refer to “Edit Resources” section in the *Qlarity Foundry User Guide*.

For information on downloading new firmware, downloading a user application, and determining the size of a user application, refer to the *Qlarity Foundry User Guide*.

1.3.7 Watchdog Timer

A watchdog timer can be added to enforce proper operation of the QTERM-G70. The watchdog timer will reset the terminal if there is a problem that causes the firmware to lock up. This does not apply to software deadlocks in the Qlarity code. If that is required, then the Qlarity watchdog timer should be used, using the WatchdogEnable and WatchdogReset APIs.

1.4 Installing to NEMA-4 Specifications

A QTERM-G70 terminal uses a rugged, glass-filled polyester (UL 94V-0) case designed to mount into a panel or drywall. When properly installed in a NEMA-4 rated panel, the QTERM-G70 meets all NEMA-4 specifications including hose-down, icing, and salt spray.

A QTERM-G70 terminal can be installed in either a landscape or portrait orientation. When installing a terminal, you generally take the following steps.

- Decide whether you want to mount and use the terminal in a portrait or landscape orientation. “Portrait” means that the longest dimension is vertical; “landscape” means that the longest dimension is horizontal.
- Cut a hole in the panel or drywall. See [section 1.4.1, “Cutout for Panel Mount Configuration”](#) or [section 1.4.3, “Cutout for Drywall Mount Configuration”](#) for specifications.
- Install the QTERM-G70 terminal in the panel or drywall. See [section 1.4.2, “Installing the Panel Mount Terminal”](#) or [section 1.4.4, “Installing the Drywall Mount Terminal”](#) for instructions.
- Connect cables to the terminal. Verify that the thumb screws are tight or the locks snapped into place for each cable used.
- Apply DC power to the QTERM-G70 terminal. See [section 1.4.5, “Applying Power”](#) for information.

1.4.1 Cutout for Panel Mount Configuration

The QTERM-G70 terminal can be mounted in panels from 0 to 7 mm thick. No screw holes need to be drilled to install the terminal in the panel.

Make a rectangular hole in the panel using the following dimensions.

Landscape		Portrait	
Horizontal:	199 ± 1 mm	Horizontal:	145 ± 1 mm
Vertical:	145 ± 1 mm	Vertical:	199 ± 1 mm

Figure 5 is a diagram of the landscape cutout.

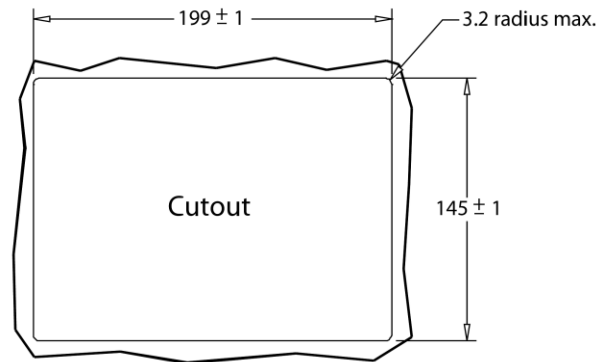



Figure 5
QTERM-G70 Landscape Cutout

File any rough edges smooth, especially on the face of the panel.

1.4.2 Installing the Panel Mount Terminal

NOTE  Use of an anti-static strap is recommended when performing installation and maintenance.

Take the following steps to install the terminal.

1. Verify that the panel surface around the cutout is clean and free of rough edges. A gasket built into the terminal will seal against this surface. Dirt or imperfections on the panel may prevent a proper seal.
2. Place the terminal into the panel cutout and verify that the terminal is oriented correctly. The touch screen legend may indicate the orientation. If not, you can determine which side should be at the top by the position of the serial port on the back panel as follows:
 - Landscape
When looking at the front of the unit, the back panel serial port(s) should be on the bottom of the terminal.
 - Portrait
When looking at the front of the unit, the back panel serial port(s) should be on the left side of the terminal.

Refer to [Figure 6](#).

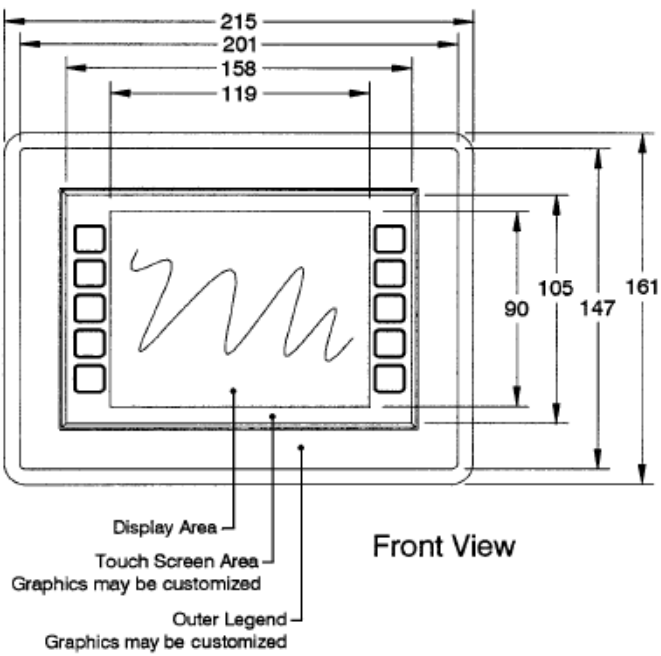

Figure 6
QTERM-G70 Front Panel Mount

3. On the back of the panel, place the terminal mounting bracket against the back of the terminal, and align it with the back panel. Refer to Figure 7.

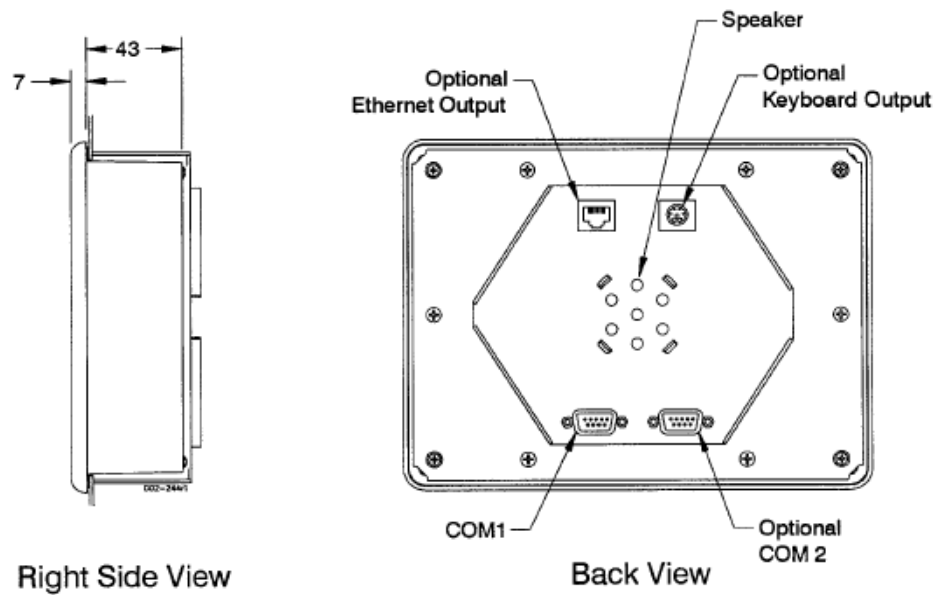



Figure 7
QTERM-G70 Back Panel Mount

4. Fasten the six screws (supplied with the terminal).

1.4.3 Cutout for Drywall Mount Configuration

The QTERM-G70 terminal with the drywall mount configuration will accommodate drywall thicknesses of 7 mm to 18 mm. The panel may be cut by using the template supplied with the unit or by using the dimensions given below. To use the template, simply identify where the unit is to be placed on the wall and tape the template up into position. Next cut along the indicated line. The cutout dimensions with appropriate tolerances are as follows.

Landscape	Portrait
Horizontal: 199 ± 1 mm	Horizontal: 145 ± 1 mm
Vertical: 145 ± 1 mm	Vertical: 199 ± 1 mm

NOTE  Care must be taken not to make the cutout oversize.

1.4.4 Installing the Drywall Mount Terminal

NOTE  Use of an anti-static strap is recommended when performing installation and maintenance.

Take the following steps to install the terminal. Refer to Figure 8.

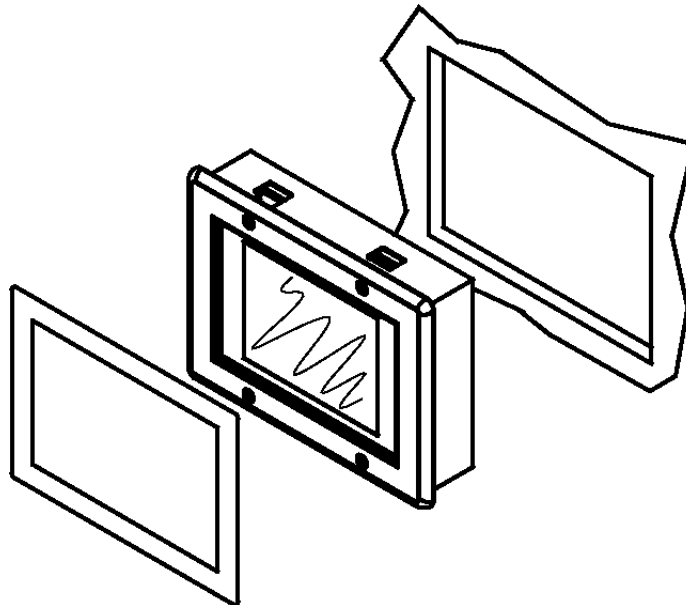

*Figure 8
QTERM-G70 Drywall Mount*

1. Verify that the unit is in the correct orientation. The touchscreen legend may indicate the orientation. If not, the top side may be identified by the position of the serial port(s) on the back panel as follows:

- Landscape
When looking at the front of the unit, the back panel serial port(s) should be on the bottom of the terminal.
 - Portrait
When looking at the front of the unit, the back panel serial port(s) should be on the left side of the terminal.
2. Connect all necessary cables to their correct places on the back panel.
 3. Insert the terminal into the cutout in the wall. If the unit will not fit into the opening, check to make sure that the cam locks on the top and bottom are not protruding from the case.
 4. Tighten all four screws on the front panel until the unit seats firmly in the cutout. The screws should be tightened approximately 2-3 full turns after a slight resistance is felt.

NOTE  *Do not over tighten the screws. Doing so will damage the cam locks and the unit will no longer mount securely into the wall.*

5. Using the supplied legend, remove the adhesive back and install on the front of the unit over the top of the four screws as indicated in the figure.

1.4.4.1 Removing the Drywall Mount Terminal

Removal of the G70 terminal requires the replacement of the outer legend. Replacements may be ordered from Beijer Electronics.

1. Remove the outer legend on the front of the unit to expose the four mounting screws.
2. Turn the screws counterclockwise until they begin to back out of the unit.
3. Gently pull the terminal from the wall cutout.

1.4.5 Applying Power

Power is supplied to the QTERM-G70 terminal via the primary serial port connector. Refer to [section 1.2.1, “Serial Ports”](#) for power and ground pin assignments. DC power must be in the range of 8 to 26 volts (the current will vary depending on the input voltage; see table below).

CAUTION



QTERM-G70 power must come from an SELV (Safety Extra Low Voltage) power source and should have a current limit on its output of 5 Amperes. It must provide a minimum of 8 volts DC power and be limited to a maximum of 26 volts DC. Limiting may be inherent to the supply or may be provided by supplementary overcurrent devices. If the QTERM-G70 does not respond or exhibits abnormal behavior on power up, disconnect power and contact Beijer Electronics for technical support.

Current Consumption			
Terminal	12 VDC	24 VDC	PoE
Standard unit (color, no options, idle)	400 mA	240 mA	120 mA
Standard TFT unit (TFT, no options, idle)	675 mA	350 mA	190 mA
Standard unit, active	add 90 mA	add 40 mA	add 15 mA
Standard TFT unit, active	add 90 mA	add 50 mA	add 15 mA
With keyboard option and keyboard attached	add 70 mA	add 35 mA	N/A
With Ethernet option and connection	add 40 mA	add 20 mA	N/A

1.5 Powering On the Terminal for the First Time

When you connect power to the QTERM-G70 terminal, it automatically loads the application saved in flash memory into RAM memory and executes the application. If no application is present, the terminal display may be blank but the backlighting verifies it is powered on.

When you power on the terminal for the first time, a demo application (or a special application custom designed for your company) loads. The demo application will help you verify that the terminal is operating properly. Follow the on-screen prompts or any documentation accompanying the program to guide you through tests or demonstrations designed to verify terminal operation.

Once you have verified that the terminal is functioning properly, refer to [Chapter 8, “Power On Setup”](#) for information on configuring your terminal. The Power On Setup utility includes functions to do the following:

- Change orientation of the terminal (portrait or landscape)
- Download a new user application to the terminal
- Select the application mode
- Set up communications settings for the terminal
- Adjust display contrast or backlight
- Enter network (Ethernet) settings
- Enter/change password (if used)
- Set the real-time clock

Notes

CHAPTER 2

QTERM-G75 TERMINAL

2.1 Product Description

The QTERM-G75 terminal is a large display Ethernet-enabled graphic terminal with object-based programming. It features a robust list of industrial grade hardware features and options.

The QTERM-G75 features a VGA, 640x480 pixel, active-matrix TFT LCD display (256 colors). It uses a dual lamp cold-cathode fluorescent backlight (CCFL). The CCFL provides high contrast and easy readability and is replaceable. The analog-resistive touch screen covers the full viewable area of the display as well as the pre-labeled legend underlay on each side of the display.

The QTERM-G75 comes equipped with one serial port using an EIA-232, EIA-422, or EIA-485 interface. A second serial port, an Ethernet port, and a PS/2 keyboard port are available as options.

Possible input devices include the touch screen and attachable keyboard (with an optional PS/2 connector). Custom configurations of the QTERM-G75 can also support an external keypad, a dual EIA-232 full serial port card or a quad EIA-232 full serial port card (contact Beijer Electronics for details). A speaker, which has programmable pitch and duration, comes standard, as does a battery-backed real-time clock. Other options include: an audio decoder for playing audio wave files, a hardware watchdog timer, and a 5 V/100 mA output from the auxiliary serial port to power external devices.

The QTERM-G75 terminal stores the firmware and the user application in a compressed format in flash memory and then transfers them to RAM memory when the terminal is powered on. The terminal is equipped with eight megabytes of flash memory and 32 megabytes of RAM memory. The Power-over-Ethernet units is equipped with four megabytes of flash memory and sixteen megabytes of RAM.

The outer legend can be customized with your logo/name or graphics. The inner legend underlay around the display can be customized with your touch keys and graphics.

The QTERM-G75 terminal requires a DC power source in a range of 8 to 26 VDC. This power is supplied via the main DB9 serial connector. Other options for supplying power to the QTERM-G75 are PoE (Power-over-Ethernet) or five volts from a well-regulated power supply via the main DB9 serial connector. Please contact Beijer Electronics for more information about this option.

2.1.1 Specifications

The following tables contain the technical specifications for the QTERM-G75.

TERMINAL DISPLAY	
Active Matrix (standard)	TFT 256 colors
Enhanced TFT (optional)	Enhanced TFT 256 colors
Pixels	640 x 480
Dot pitch	0.33 mm
Lighting	Dual lamp cold-cathode fluorescent, brightness software-controllable
Backlight brightness	TFT 550 nits typical, enhanced TFT 800 nits typical
TOUCH SCREEN	
Analog-resistive operation	
Transparent touch area over viewable display	
Labeled touch underlay area on each side of display	
INTERFACE	
Standard	EIA-232 serial port with hardware or software handshaking
Baud rates	600 – 115,200 bps
Flow control	None XonXoff (software) RTS/CTS (hardware)
Data formats	7 or 8 data bits 1 or 2 stop bits Even, odd, or no parity (PC Tools support only 8 data bits)
Connector	DB9f (2 with optional second serial port) 8-pin modular (RJ45) with Ethernet option PS/2 keyboard connector (optional)
Options	Primary serial port configurable as EIA-232, EIA-422, or EIA-485 Secondary serial port available (EIA-232, EIA-422, or EIA-485) Ethernet 10/100Base-T with support for TCP/IP networking PS/2 keyboard port Additional dual or quad full EIA-232 serial port cards available
MEMORY	
Standard	8 Mbytes flash and 32 Mbytes SDRAM
PoE	4 Mbytes flash and 16 Mbytes SDRAM

SPEAKER	
Standard	Software programmable pitch and duration
Optional	Audio (.wav) decoder
REAL-TIME CLOCK	
Independent processor-based, real-time clock equipped with a battery backup	
PHYSICAL	
Configuration	Panel-mount
Housing	Aluminum, accommodates panels from 0 to 12 mm thick with standard screws
Size	330 x 260 x 55.3 mm
Weight	2.9 kg
Processor	400 MHz Intel XScale core (standard)
	200 MHz Intel XScale core (PoE)
ENVIRONMENTAL	
Sealing	NEMA-4 front panel
Temperature	Operating: -10 to 60 °C Storage: -20 to 70 °C
Humidity	0 to 95%, non-condensing
Vibration	5 to 5000 Hz, 4 g RMS
Shock	20 g, 3 ms, any axis
POWER	
8 to 26 VDC (See section 2.4.3 for current consumption)	
PoE (Power-over-Ethernet)	
SOFTWARE	
Programming language	Qlarity (object-based)
Design environment	Qlarity Foundry (Windows)
Command line compiler	Qlarity (Win32 or Linux)
CUSTOMIZING	
Outer legend	Customize with logo/name or graphics
Inner legend	Customize with touch keys and graphics
CERTIFICATION	
FCC Part 15, Class A CE Certification	

2.2 Supported Interfaces

2.2.1 Serial Ports

The QTERM-G75 comes standard with one serial port with DB9f connector. The serial port interface can be EIA-232, EIA-422, or EIA-485. A second serial port is available as an option, as well as two or four additional full EIA-232 serial ports are also optional.

NOTE  *The primary and auxiliary serial ports are wired as Data Communications Equipment (DCE).*

EIA-232	with proper cables and grounding the terminal can communicate up to five meters at a top speed of 115,200 bps
EIA-422	permits operation at distances up to 2,000 meters
EIA-485	permits multiple terminals to be connected in a multi-drop chain

Figure 9 shows the serial connector's orientation.

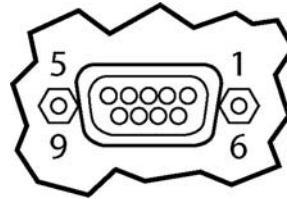

Figure 9
QTERM-G75 Serial Connector

The following table shows the pinouts for each type of serial interface.

Pin	232	422	485
1	—	Tx-	RTx-
2	Tx	Tx+	RTx+
3	Rx	Rx+	—
4	—	—	—
5	Ground	Ground	Ground
6	—	Rx-	—
7	CTS (in)		—
8	RTS (out)		—
9	Power	Power	Power

Power is supplied to the terminal through pin 9 and ground is supplied through pin 5 of the primary serial port connector.

2.2.2 Optional Ethernet Port

The optional Ethernet port has a standard 10/100Base-T interface with an 8-pin (RJ-45) modular jack connector and uses TCP/IP protocol. The connector orientation and pinout table are shown in Figure 10.

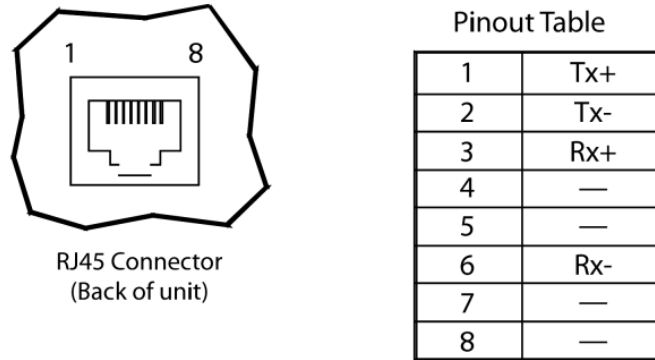

RJ45 Connector
(Back of unit)

Figure 10
QTERM-G75 Ethernet Port Pinouts

2.2.3 Optional PS/2 Keyboard Interface

The optional PS/2 port can be used to connect a standard PS/2 keyboard to the QTERM-G75 terminal. The connector orientation and pinout table are shown in Figure 11.

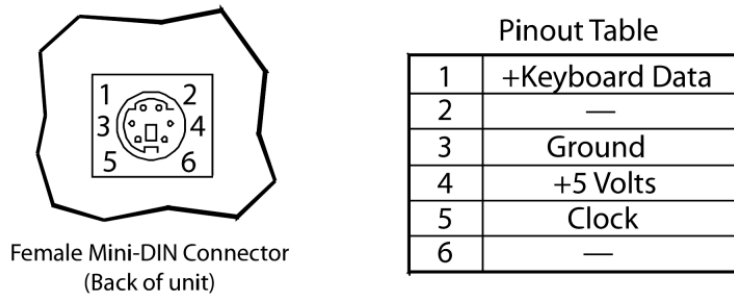

Female Mini-DIN Connector
(Back of unit)

Figure 11
QTERM-G75 PS/2 Keyboard Interface Pinouts

2.2.4 Optional 5 Volt Power Supply on Secondary Serial Port

The secondary serial port interface (if included) can optionally be configured to provide a 5 volt DC power supply. The supply can provide up to 100 mA current to a serial peripheral device (such as a barcode reader) connected to COM2. The 5 volt supply is provided on pin 9 and returns to ground on pin 5.

2.2.5 Optional Dual and Quad EIA-232 Serial Port Card

An additional two or four EIA-232 serial ports can be added to the QTERM-G75. **These serial ports have all necessary signals for EIA-232 serial communications and are wired as Data Terminal Equipment (DTE).**

The additional serial port option will add approximately 10 mA to the total current draw of the terminal plus 15 mA per connected serial cable.

The following table shows the pinouts for the additional serial port option.

Additional EIA-232 Serial Port Pinouts	
1	DCD (in)
2	Rx (in)
3	Tx (out)
4	DTR (out)
5	GND
6	DSR (in)
7	RTS (out)
8	CTS (in)
9	RI (in)

2.2.6 Optional Power-over-Ethernet Module

The optional Power-over-Ethernet module allows the user to provide power and communications to the QTERM-G75. The power can be provided from an IEEE 802.3af compliant hub or switch as well as from a standard power supply.

2.3 Terminal Components

2.3.1 Touch Screen

The QTERM-G75 touch screen provides user input through any number of touch keys located on or around the display. The standard key legend shown in [Figure 12](#) provides areas for five soft keys down each side of the display. A custom legend underlay can be ordered to personalize the terminal for your application.

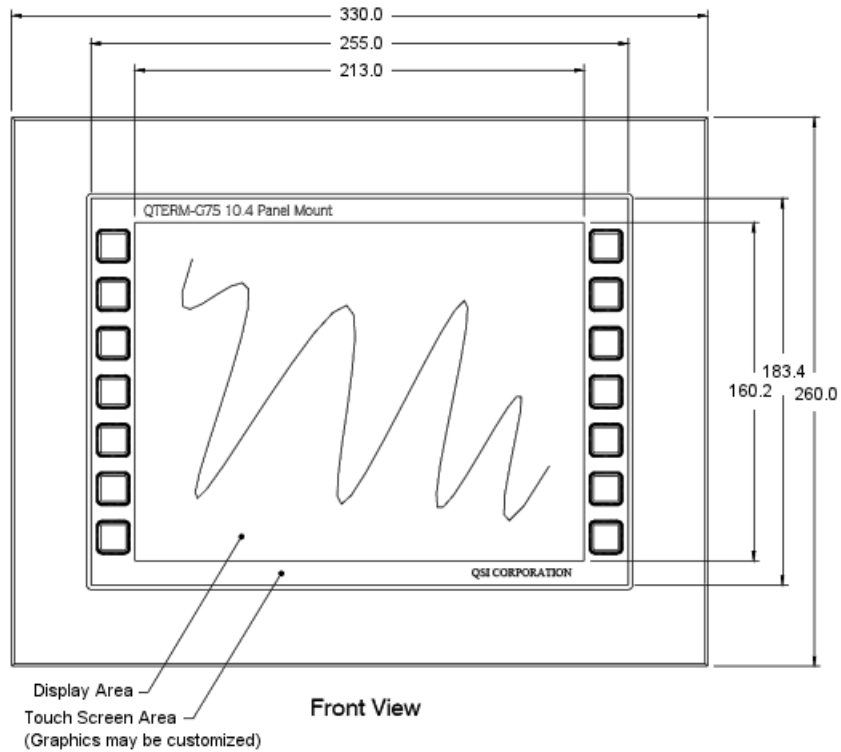

Figure 12
QTERM-G75 Standard Key Legend

Touch keys can also be defined in your user applications at any location on or around the display. Touch keys may be any size.

2.3.2 Keyboard

Using the optional PS/2 port, a standard PC keyboard may be used in addition to, or in place of, the touch screen. Power On Setup, the terminal setup utility, recognizes both touch keys and keyboard keys.

2.3.3 Keypad

The QTERM-G75 terminal can optionally include electronics for attaching an external keypad with up to 8 columns by 8 rows and up to 6 keypad LEDs. Contact Beijer Electronics for more information.

The keypad option will add 10 mA to the total current draw of the terminal plus the current driven out the LED outputs pins. The LED outputs are five-volt open-collector signals with a 1000 Ohm series resistor. This results in an approximate maximum output current drive of 5 mA on those pins. There are two connectors on the keypad module to facilitate connecting different sized keypads. The pinouts for those connectors are shown in the following table.

Connector J1 - 0.1 Inch Pitch 16-pin Single-row Connector			
1	GND	9	Row 5
2	LED 1	10	Row 6
3	Row 1	11	Col 1
4	Row 2	12	Col 2
5	Row 3	13	Col 3
6	Row 4	14	Col 4
7	GND	15	Col 5
8	LED 2	16	Col 6

Connector J2 - 0.1 Inch Pitch 24-pin Dual-row Connector			
1	Row 1	13	Col 1
2	5 V or 3.3 V	14	LED 4
3	Row 2	15	Col 2
4	GND	16	LED 3
5	Row 3	17	Col 3
6	LED 6	18	LED 2
7	Row 4	19	Col 4
8	LED 5	20	LED 1
9	Row 5	21	Col 5
10	Row 8	22	Col 6
11	Row 6	23	Col 8
12	Row 7	24	Col 7

2.3.4 Speaker

A speaker is built into the QTERM-G75 terminal and faces to the back of the unit. Audio can be linked to events or actions (e.g., screen press, timer, etc.). Pitch and duration of a sound are controlled by API functions called from the user application. Refer to “Controlling the Speaker” section in the *Qlarity-based Terminal Programmer's Reference Manual*.

Optionally, an audio (.wav) decoder can be added to the QTERM-G75 to allow the speaker to play audio files. The audio decoder supports wave files meeting the following criteria:

- Sample rate of 8 kHz, 11.025 kHz, 16 kHz or 22.050 kHz
- Resolution of 8 or 16 bits per sample.

The audio decoder circuit amplifies the signal to 0.5 W rms at the speaker.

2.3.5 Real-Time Clock

The QTERM-G75 terminal is equipped with a battery-backed, real-time clock. The real-time clock can be used to time/date stamp messages or for timed polling and program execution.

WARNING

There may be danger of leakage if the battery is incorrectly replaced, creating a potential health hazard. Replace the battery only with the same (CR1220) or equivalent type as recommended by the manufacturer. Dispose of used batteries according to the manufacturer's instructions.

2.3.6 System Memory

The QTERM-G75 terminal stores the firmware and user applications in a compressed format in flash memory and then transfers them to RAM memory when the terminal is powered on. Eight megabytes of flash memory and 32 megabytes of RAM memory are included on the standard unit. The PoE unit has four megabytes of flash memory and sixteen megabytes of RAM memory.

For information on using resources efficiently to conserve memory when creating a user application, refer to “Edit Resources” section in the *Qlarity Foundry User Guide*.

For information on downloading new firmware, downloading a user application, and determining the size of a user application, refer to the *Qlarity Foundry User Guide*.

2.3.7 Watchdog Timer

A watchdog timer can be optionally added to enforce proper operation of the QTERM-G75. The watchdog timer will reset the terminal if there is a problem causing the firmware to lock up. This does not apply to software deadlocks in the Qlarity code. If that is required, then the Qlarity watchdog timer should be used, using the WatchdogEnable and WatchdogReset APIs.

2.4 Installing to NEMA-4 Specifications

A QTERM-G75 terminal uses a rugged aluminum case designed to mount into a panel. When properly installed in a NEMA-4 rated panel, the QTERM-G75 meets all NEMA-4 specifications including hose-down, icing, and salt spray.

A QTERM-G75 terminal can be installed with either landscape or portrait orientation. When installing a terminal, you generally take the following steps.

- Decide whether you want to mount and use the terminal in portrait or landscape orientation. “Portrait” means that the longest dimension is vertical; “landscape” means that the longest dimension is horizontal.

- Cut a hole in the panel and drill the mounting holes. See [section 2.4.1, “Cutting Out the Panel”](#) for specifications.
- Install the QTERM-G75 terminal in the panel. See [section 2.4.2, “Installing the Terminal”](#) for instructions.
- Connect cables to the terminal. Verify that the thumb screws are tight or the locks snapped into place for each cable used.
- Apply DC power to the QTERM-G75 terminal. See [section 2.4.3, “Applying Power”](#) for information.

2.4.1 Cutting Out the Panel

The QTERM-G75 terminal can be mounted in panels from 0 to 12 mm thick. Fourteen screw holes need to be drilled to install the terminal in the panel. The mounting holes should be 4.6 mm in diameter and drilled as shown in the figure below. Make a rectangular hole in the panel using the following dimensions.

Landscape	Portrait
Horizontal: 291 ± 1 mm	Horizontal: 221 ± 1 mm
Vertical: 221 ± 1 mm	Vertical: 291 ± 1 mm

Figure 13 is a diagram of the landscape cutout.

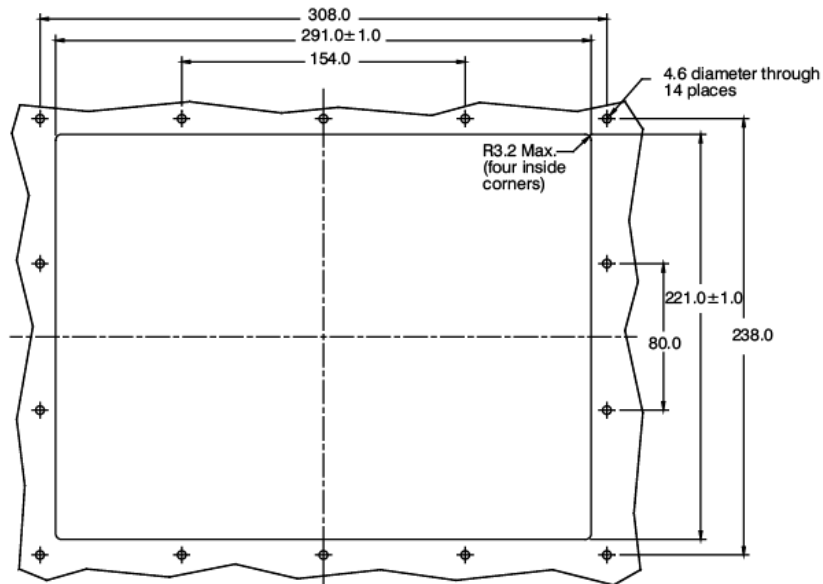

Panel Cutout Dimensions

Figure 13
QTERM-G75 Landscape Cutout

File any rough edges smooth, especially on the face of the panel.

2.4.2 Installing the Terminal

Take the following steps to install the terminal.

1. Verify that the panel surface around the cutout and mounting holes is clean and free of rough edges. A gasket built into the terminal will seal against this surface. Dirt or imperfections on the panel may prevent a proper seal.
2. Place the terminal into the panel cutout (inserting the studs into the mounting holes) and verify that the terminal is oriented correctly. The touch screen legend may indicate the orientation. If not, you can determine which side should be at the top by the position of the serial port on the back panel as follows:
 - Landscape
When looking at the front of the unit, the back panel serial port(s) should be near the top of the terminal.
 - Portrait
When looking at the front of the unit, the back panel serial port(s) should be on the right side of the terminal.

Refer to Figure 14.

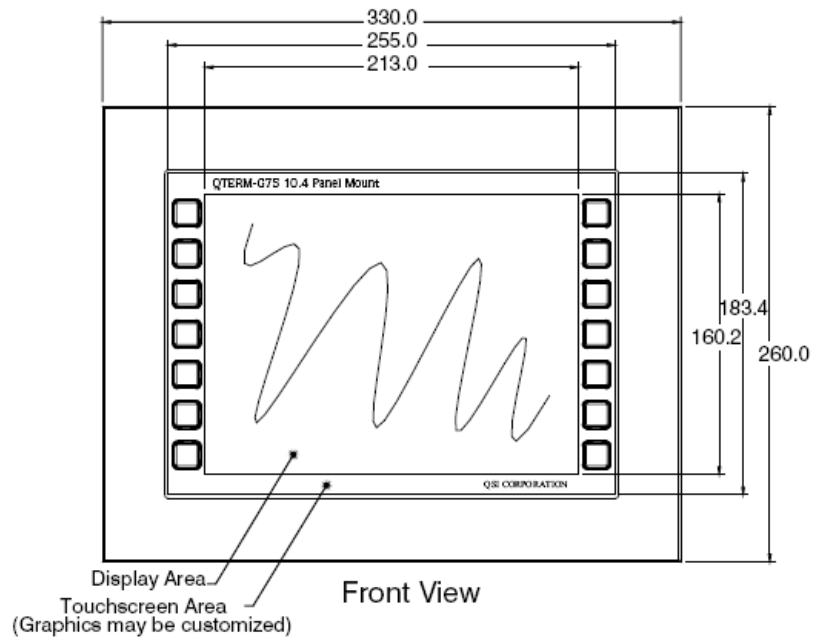

Figure 14
QTERM-G75 Front Panel Mount

3. On the back of the panel, align the terminal mounting bracket holes with the mounting studs and place the bracket against the back of the panel. Refer to Figure 15.

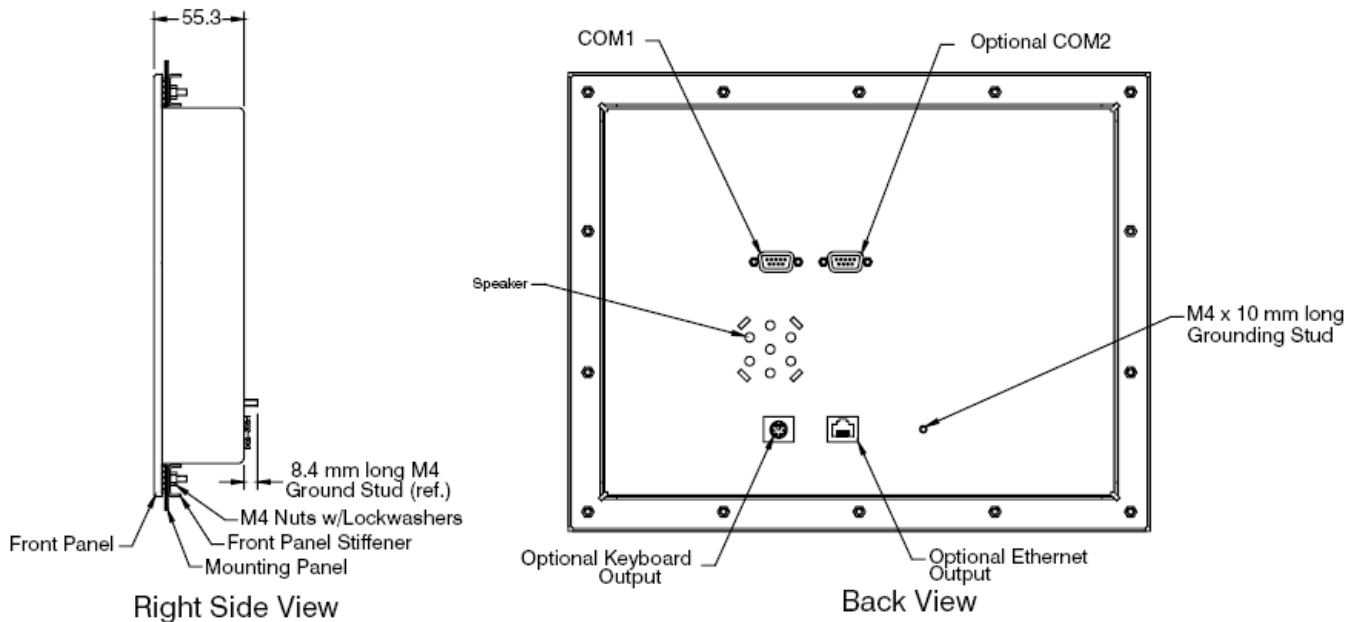

Figure 15
QTERM-G75 Back Panel Mount

4. Attachments with lockwashers (supplied with the terminal) onto each of the fourteen mounting studs. Tighten all nuts to create the seal between the terminal gasket and the panel. Avoid overtightening the nuts.

2.4.3 Applying Power

Power is supplied to the QTERM-G75 terminal via the primary serial port connector. Refer to [section 2.2.1, “Serial Ports”](#) for the pin assignments for power and ground. DC power must be in the range of 8 to 26 volts (the current will vary depending on the input voltage; see table below).

CAUTION



QTERM-G75 power must come from an SELV (Safety Extra Low Voltage) power source and should have a current limit on its output of 5 Amperes. It must provide a minimum of 8 volts DC power and be limited to a maximum of 26 volts DC. Limiting may be inherent to the supply or may be provided by supplementary overcurrent devices. If the QTERM-G75 does not respond or exhibits abnormal behavior on power up, disconnect power and contact Beijer Electronics for technical support.

Current Consumption		
Terminal	12 VDC	24 VDC
Standard unit idle	950 mA	475 mA
Enhanced unit idle	1.0 A	500 mA
Standard unit, active	add 100 mA	add 60 mA
Enhanced unit, active	add 100 mA	add 60 mA
With keyboard option and keyboard attached	add 70 mA	add 35 mA
With Ethernet option and connection	add 40 mA	add 20 mA

2.4.4 Powering On the Terminal for the First Time

When you connect power to the QTERM-G75 terminal, it automatically loads the application saved in flash memory into RAM memory and executes the application. If no application is present, the terminal display is blank but the back-lighting verifies that it is powered on.

When you power on the terminal for the first time, a demo application (or a special application custom designed for your company) loads. The demo application will help you verify that the terminal is operating properly. Follow the on-screen prompts or any documentation accompanying the program to guide you through tests or demonstrations designed to verify terminal operation.

Once you have verified that the terminal is functioning properly, refer to [Chapter 8, “Power On Setup”](#) for information on configuring your terminal. The Power On Setup utility includes functions to do the following:

- Change orientation of the terminal (portrait or landscape)
- Download a new user application to the terminal
- Select the application mode
- Set up communications settings for the terminal
- Adjust display contrast or backlight
- Enter network (Ethernet) settings
- Enter/change password (if used)
- Set the real-time clock

Notes

3.1 Product Description

The QTERM-G55 is a rugged, handheld or panel-mount Ethernet-enabled graphic terminal with object-based programming. It features a robust list of industrial grade hardware features and options.

The QTERM-G55 features a QVGA, 320x240 pixel, LCD transfective FSTN, grayscale (16 shades) display or optional active-matrix TFT (256 colors) display. Both displays use a light emitting diode (LED) backlight. The LED provides reasonable contrast at low power consumption and easy readability. The FSTN contrast is software-controlled and compensated for temperature. The transfective display provides excellent contrast in sunlight and high ambient light environments.

The QTERM-G55 comes equipped with one serial port using an EIA-232, EIA-422, or EIA-485 interface. A second serial port or an Ethernet or Power-over-Ethernet port are available as options. Units with the emergency stop (E-stop) option may be equipped with a single serial port, Ethernet or Power-over-Ethernet.

User input occurs through a rugged 24-key or 40-key membrane keypad with steel snap domes. The top row of keys are commonly used as soft keys to navigate through a set of changing menus at the bottom of the display. The standard keypad comes with four or five LEDs under the soft keys that can be used as status or alarm indicators. Power and shift buttons with LEDs are included on both keypad configurations. The power button puts the terminal into a sleep mode for low power consumption and provides instant-on function with no loss of program state.

The 40-key keypad allows for function / softkeys, eight-way directional control and numeric entry in the unshifted mode and alphanumeric data entry in the shifted mode. Keys can perform alternate functions when the shift key is enabled. Both the power and shift functions can be enabled or disabled in software.

The keypad legend can be customized with your logo/name and custom keys.

The QTERM-G55 terminal stores the firmware and the user application in a compressed format in flash memory and then transfers them to RAM memory when the terminal is powered on. The terminal is equipped with two megabytes of flash memory and sixteen megabytes of RAM memory.

The QTERM-G55 terminal includes a switching power supply with a wide input voltage range of 8 to 32 VDC. Typically, power is supplied through the 12-pin circular connector or integral cable (handheld) or the primary serial port (panel-mount). If the Power-over-Ethernet (PoE) option is selected, power is supplied through the Ethernet cable and your PoE-compliant hub.

3.1.1 Specifications

The following tables contain the technical specifications for the QTERM-G55.

TERMINAL DISPLAY	
Grayscale (standard)	FSTN 16 shades of gray
Active Matrix Color (optional)	TFT 256 colors
Pixels	320 x 240
Dot Pitch	FSTN 0.24 mm TFT 0.227 mm
FSTN Contrast	Software-controlled, temperature compensated
Lighting	Light emitting diode brightness is software-controllable
Backlight Brightness	FSTN 10 nits typical TFT 200 nits typical
KEYPAD	
24- or 40-keys	
Steel snap domes in membrane	
Lighted keypad with electroluminescent lighting (optional)	
Optional emergency stop switch (2-pole, normally closed)	
INTERFACE	
Standard	EIA-232 serial port with hardware or software handshaking
Baud rates	600 – 115,200 bps
Flow control	None XonXoff (software) RTS/CTS (hardware)
Data formats	7 or 8 data bits 1 or 2 stop bits Even, odd, or no parity (PC Tools support only 8 data bits)
Connector	Handheld - 12-pin round (Hirose HR30-8R-12SC) Integral cable with DB15f
	Panel-mount - DB9f (2 with optional second serial port) 8-pin modular (RJ45) with Ethernet option
Options	Primary serial port configurable as EIA-232, EIA-422, or EIA-485 Secondary serial port available (EIA-232, EIA-422, or EIA-485) Ethernet 10Base-T with support for TCP/IP networking Power-over-Ethernet

MEMORY	
Standard	2 Mbytes flash and 16 Mbytes SDRAM
SPEAKER	
Standard	Software programmable pitch and duration
Optional	Audio (.wav) decoder
REAL-TIME CLOCK	
Optional	Independent processor-based, real-time clock equipped with a battery backup
PHYSICAL	
Configuration	Panel-mount
	Handheld
Housing	Handheld - ABS/bicarbonate case with molded rubber boot
	Panel-mount - ABS/poly carbonate case with rubber overmold trim
Size	Handheld - 129 x 234 x 43 mm
	Panel-mount - 127 x 228.6 x 95.6 mm
Mass	Handheld - 520 g
	Panel-mount - 700 g
Processor	ARM720T 77 Mhz
ENVIRONMENTAL	
Sealing	Handheld - NEMA-12 (Standard) NEMA-4 (optional) Panel-mount - NEMA-4
Temperature	Operating: -20 to 60 °C Storage: -40 to 85 °C
Humidity	0 to 95%, non-condensing
Vibration	5 to 2000 Hz, 4 g RMS
Shock	20 g, 3 ms, any axis
POWER	
8 to 32 VDC (See section 3.4.3 for current consumption)	
PoE (Power-over-Ethernet)	
SOFTWARE	
Programming language	Qlarity (object-based)
Design environment	Qlarity Foundry (Windows)
Command line compiler	Qlarity (Win32 or Linux)

CUSTOMIZING	
Keypad legend	Customize with logo/name or graphics
CERTIFICATION	
FCC Part 15, Class B (Class A with Ethernet or PoE option)	
CE Certification	

3.2 Supported Interfaces

3.2.1 Handheld Connector Interface

The QTERM-G55 handheld terminal comes standard with one serial port through a 12-pin round connector (Hirose HR30-8R-12SC) or integral cable with strain relief, terminated with a DB15f connector. The serial port interface can be EIA-232, EIA-422 or EIA-485. A second serial port is available as an option on non-E-stop units.

EIA-232	with proper cables and grounding the terminal can communicate up to five meters at a top speed of 115,200 bps
EIA-422	permits operation at distances up to 2,000 meters
EIA-485	permits multiple terminals to be connected in a multi-drop chain

Figure 16 shows the handheld unit connector orientation.

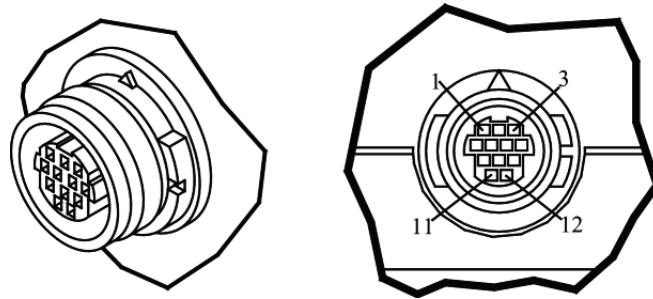

Figure 16
QTERM-G55 Handheld Connector

3.2.1.1 Power Interface

The following table shows the pinout for each type of power interface.

Pin	Regulated (standard)	5 Volt Unregulated	Power-over-Ethernet
1	8 - 32 VDC	4.5 - 5.5 VDC	No connect
2	Ground	Ground	Ground
11	No connect	No connect	PoE V+
12	No connect	No connect	PoE V-

The Power-over-Ethernet voltage difference [(PoE V+) -(PoE V-)] is typically 48 VDC. See the IEEE 802.3af specification for details.

3.2.1.2 Primary Serial Interface

The following table shows the power supply pinout for each type of primary serial interface.

Pin	EIA-232	EIA-422	EIA-485
3	Tx	Tx+	RTx+
4	RTS (out)	Tx-	RTx-
5	Rx	Rx+	No connect
6	CTS (in)	Rx-	No connect

3.2.1.3 Secondary Serial Interface or Network Interface

The following table shows the power supply pinout for each type of secondary serial interface or network interface.

Pin	EIA-232	EIA-422	EIA-485	Ethernet (including PoE)
7	Tx	Tx+	RTx+	Tx+
8	RTS (out)	Tx-	RTx-	Tx-
9	Rx	Rx+	No connect	Rx+
10	CTS (in)	Rx-	No connect	Rx-

3.2.1.4 E-stop Option

If the terminal is equipped with the E-stop option, the pinout changes to accommodate the switch signals, as shown below. Note that a secondary serial interface is not available if the E-stop option is selected.

3.2.1.4.1 Power Interface with E-stop Option

The following table shows the pinout for each type of power interface when the E-stop option is selected.

Pin	Regulated (standard)	5 Volt Unregulated	Power-over-Ethernet
1	8 - 32 VDC	4.5 - 5.5 VDC	No connect
2	Ground	Ground	Ground
3	No connect	No connect	PoE V+
4	No connect	No connect	PoE V-

3.2.1.4.2 Serial or Network Interface with E-stop Option

The following table shows the pinout for each type of serial or network interface.

Pin	EIA-232	EIA-422	EIA-485	Ethernet (including PoE)
7	Tx	Tx+	RTx+	Tx+
8	RTS (out)	Tx-	RTx-	Tx-
9	Rx	Rx+	No connect	Rx+
10	CTS (in)	Rx-	No connect	Rx-

3.2.1.4.3 E-stop Switch Interface

The following table shows the pinout for the two-pole normally closed E-stop switch. The conductors for each pole (Pole 1 and Pole 2) of the switch are shorted until the switch is activated. After activation, each pole is an open circuit until the switch is reset.

Pin	E-stop Switch
5	Pole 1
6	Pole 1
11	Pole 2
12	Pole 2

3.2.1.5 Accessory Cable Wire Color Code

The following table shows the wire color code for the 12-pin round connector to blank accessory cable. The cable contains fifteen conductors; however, only twelve conductors are connected to pins on the round connector. Six of the fifteen conductors in the cable are wired as 100 ohm twisted pairs, as shown in the table. One of the fifteen conductors is a non-insulated drain wire which is shorted to the foil shielding in the cable. This drain wire is not connected to the round connector.

Round Connector Pin	Wire Color	Twisted Pairs
1	Brown	
2	Red with Black Stripe	
3	Orange	
4	Yellow	
5	Green with Black Stripe	
6	Blue	
7	Black	Pair #1
8	White	Pair #1
9	Red	Pair #2
10	Green	Pair #2
11	Violet	
12	Gray	
No Connect	White with Red Stripe	Pair #3
No Connect	White with Green Stripe	Pair #3
No Connect	Drain	

3.2.1.6 Integral Cable

The handheld QTERM-G55 can be optionally equipped with an integral cable (instead of the 12-pin round connector). This cable is terminated with a DB15f connector. Figure 17 shows the integral cable connector orientation.

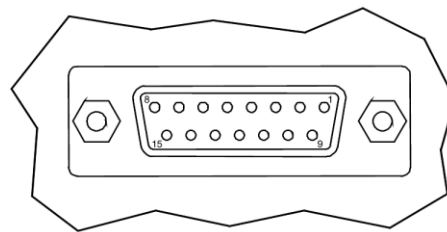

**Female DB15 Connector
(End of cable)**

*Figure 17
QTERM-G55 Integral Cable Connector*

3.2.1.6.1 Power Interface with Integral Cable

The following table shows the pinout for each type of power interface when the integral cable option is selected.

DB15f Pin	Regulated (standard)	5 Volt Unregulated	Power-over-Ethernet
9	8 - 32 VDC	4.5 - 5.5 VDC	No connect
1	Ground	Ground	Ground
15	No connect	No connect	PoE V+
8	No connect	No connect	PoE V-

3.2.1.6.2 Primary Serial Interface with Integral Cable

The following table shows the pinout for each type of serial interface.

DB15f Pin	EIA-232	EIA-422	EIA-485
11	Tx	Tx+	RTx+
5	RTS (out)	Tx-	RTx-
12	Rx	Rx+	No connect
4	CTS (in)	Rx-	No connect

3.2.1.6.3 Secondary Serial Interface or Network Interface with Integral Cable

The following table shows the pinout for each type of secondary serial interface or network interface.

DB15f Pin	EIA-232	EIA-422	EIA-485	Ethernet (including PoE)
7	Tx	Tx+	RTx+	Tx+
14	RTS (out)	Tx-	RTx-	Tx-
6	Rx	Rx+	No connect	Rx+
13	CTS (in)	Rx-	No connect	Rx-

3.2.1.7 E-stop Option with Integral Cable

If the terminal is equipped with the E-stop option and integral cable, the DB15f pinout changes to accommodate the switch signals, as shown below. Note that a secondary serial interface is not available if the E-stop option is selected.

3.2.1.7.1 Power Interface with E-stop Option and Integral Cable

The following table shows the pinout for each type of power interface when the E-stop option and integral cable are selected.

DB15f Pin	Regulated (standard)	5 Volt Unregulated	Power-over-Ethernet
9	8 - 32 VDC	4.5 - 5.5 VDC	No connect
1	Ground	Ground	Ground
11	No connect	No connect	PoE V+
5	No connect	No connect	PoE V-

3.2.1.7.2 Serial or Network Interface with E-stop Option and Integral Cable

The following table shows the pinout for each type of serial or network interface.

DB15f Pin	EIA-232	EIA-422	EIA-485	Ethernet (including PoE)
7	Tx	Tx+	RTx+	Tx+
14	RTS (out)	Tx-	RTx-	Tx-
6	Rx	Rx+	No connect	Rx+
13	CTS (in)	Rx-	No connect	Rx-

3.2.1.7.3 E-stop Switch Interface with Integral Cable

The following table shows the pinout for the two-pole normally closed E-stop switch when the integral cable option is selected. The conductors for each pole (Pole 1 and Pole 2) of the switch are shorted until the switch is activated. After activation, each pole is an open circuit until the switch is reset.

DB15f Pin	E-stop Switch
4	Pole 1
12	Pole 1
8	Pole 2
15	Pole 2

3.2.1.8 Integral Cable Wire Color Code

The following table shows the wire color code for the DB15f connector on the integral cable; this information is provided to facilitate removal of the DB15f if desired. Six of the fifteen conductors in the cable are wired as 100 ohm twisted pairs, as shown in the table. One of the fifteen conductors is a non-insulated drain wire which is shorted to the foil shielding in the cable.

DB15f Pin	Wire Color	Twisted Pairs
1	Red with Black Stripe	
2	White with Red Stripe	Pair #3
3	White with Green Stripe	Pair #3
4	Blue	
5	Yellow	
6	Red	Pair #2
7	Black	Pair #1
8	Gray	
9	Brown	
10	Drain	
11	Orange	
12	Green with Black Stripe	
13	Green	Pair #2
No 14	White	Pair #1
15	Violet	

3.2.2 Panel-mount Connector Interface

The panel-mount QTERM-G55 comes standard with one serial port with DB9f connector. The serial port interface can be EIA-232, EIA-422, or EIA-485. A second serial port is available as an option.

NOTE  *The primary panel-mount and auxiliary serial ports are wired as Data Communications Equipment (DCE).*

EIA-232	with proper cables and grounding the terminal can communicate up to five meters at a top speed of 115,200 bps
EIA-422	permits operation at distances up to 2,000 meters
EIA-485	permits multiple terminals to be connected in a multi-drop chain

Figure 18 shows the panel-mount unit serial connector orientation.

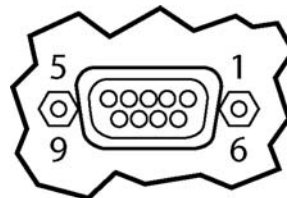

Figure 18
QTERM-G55 Panel-mount Serial Connector

The following table shows the pinouts for each type of serial interface.

Pin	232	422	485
1	—	Tx-	RTx-
2	Tx	Tx+	RTx+
3	Rx	Rx+	—
4	—	—	—
5	Ground	Ground	Ground
6	—	Rx-	—
7	CTS (in)		—
8	RTS (out)		—
9	Power	Power	Power

Power is supplied to the terminal through pin 9 and ground is supplied through pin 5 of the primary serial port connector. System ground is also connected to pin 5 of the secondary serial port connector.

3.2.2.1 Optional Ethernet Port (Panel-mount)

The optional Ethernet port has a standard 10Base-T interface with an 8-pin (RJ-45) modular jack connector and uses TCP/IP protocol.

The connector orientation and pinout table are shown in Figure 19.

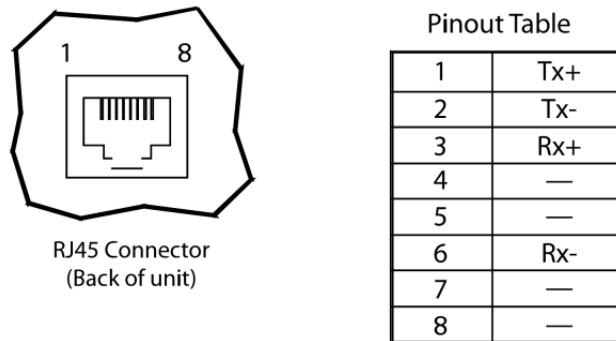

Figure 19
QTERM-G55 Ethernet Port Pinouts

3.2.3 Optional Power-over-Ethernet Module

The optional Power-over-Ethernet module allows the user to provide power and communications to the QTERM-G55. The power can be provided from an IEEE 802.3af compliant hub or switch as well as from a standard power supply.

3.2.3.1 Power Requirements

The optimal power supplied to the QTERM-G55 through the PoE port is 48 VDC. The analog-resistive touch screen covers the full viewable area of the display. The touch screen is the primary mechanism for user input.

For communications, the QTERM-G72 comes equipped with two serial ports. The primary serial port is software-configurable to EIA-232 (with RTS/CTS flow control), EIA-422 or EIA-485 interfaces. The secondary serial port uses an EIA-232 interface with hardware (RTS/CTS) or software flow control. The product also includes one 10/100Base-T Ethernet (RJ45 connector) and one USB 2.0 full speed port (mass storage devices only). The I/O connectors are accessible at the terminal back panel and are angled towards the bottom of the terminal to facilitate mounting in shallow panels areas.

Other key standard features include a speaker, which has programmable pitch and duration, and an audio decoder for playing audio wave files. The terminal also includes a battery-backed real-time clock and a hardware watchdog timer.

The terminal stores the firmware and the user application in a compressed format in flash memory and then transfers them to RAM memory when the terminal is powered on. The terminal is equipped with four megabytes of flash memory and 32 megabytes of RAM memory.

The QTERM-G72 electronics are packaged in a rugged and attractive black thermoplastic NEMA-4X housing which accommodates the same panel cutout as our QTERM-G70 terminal. Optional pad printing of the front bezel with logo/name or graphics is available as an option.

The QTERM-G72 terminal requires a DC power source in a range of 10 to 32 VDC. This power can be supplied either via the main DB9 serial connector or the 3-pin power terminal strip (which includes power input, return and chassis ground).

DC, although the unit will operate with a power input as low as 36 VDC, or as high as 57 VDC (see IEEE 802.3af specification). The power required to operate the terminal with out any additional options is listed below.

Current Consumption	
Terminal	48VDC
G55 STN Idle	70 mA
Active Add	+10 mA

3.2.3.2 Pinouts (Panel-mount)

In accordance with the PoE standard (IEEE 802.3af), the PoE port is insensitive to polarity of the power supply and can receive power in either mode A (superimposed on the transmit and receive twisted pair conductors) or mode B (using the additional twisted pair conductors). This

yields four possible ways to apply power to the PoE port as shown in the following table. The table also shows the conductor assignment for the transmit and receive lines as a reference.

Port Pin Assignment	
Conductor	Data
1	Tx+
2	Tx-
3	Rx+
4	PoE V+
5	
6	Rx-
7	PoE V-
8	

NOTE  The pinouts for the PoE option on the handheld terminal are shown in [section 3.2.1, “Handheld Connector Interface.”](#)

3.3 Terminal Components

3.3.1 Display

The standard QTERM-G55 features a QVGA, 320x240 pixel, LCD transfective FSTN, gray-scale (16 shades) display. It uses a light emitting diode (LED) backlight. The LED provides reasonable contrast at low power consumption and easy readability. The contrast is software-controlled and compensated for temperature. The transfective display provides excellent contrast in sunlight and high ambient light environments. Refer to Figure 20.

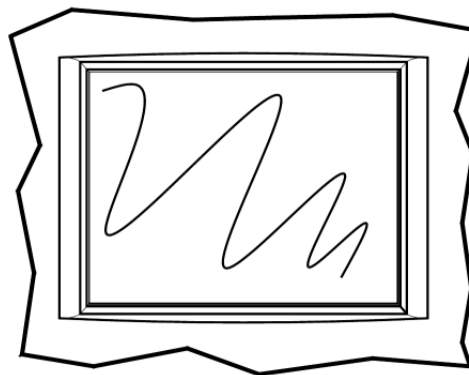

Figure 20
QTERM-G55 Display

The QTERM-G55 may be optionally equipped with a color QVGA, 320x240 pixel, active-matrix TFT LCD (256 colors). It also uses a light emitting diode (LED) backlight, with a typical brightness of 200 nits.

3.3.2 Keypad

User input occurs through a rugged 24-key or 40-key membrane keypad with steel snap domes. The top row of keys is commonly used as soft keys to navigate through a set of changing menus at the bottom of the display. The standard keypad comes with four or five LEDs under the soft keys that can be used as status or alarm indicators. Power and shift buttons with LEDs are included on both keypad configurations. The power button puts the terminal into a sleep mode for low power consumption and provides instant-on function with no loss of program state.

The 40-key keypad allows for function / softkeys, eight-way directional control and numeric entry in the unshifted mode and alphanumeric data entry in the shifted mode. Keys can perform alternate functions when the shift key is enabled. The power and shift functions can be enabled or disabled in software.

The keypad legend can be customized with your logo/name and custom keys.

3.3.3 Speaker

A speaker is built into the QTERM-G55 terminal and faces to the back of the unit. Audio can be linked to events or actions (e.g., screen press, timer, etc.). Pitch and duration of a sound are controlled by API functions called from the user application. Refer to “Controlling the Speaker” section in the *Qlarity-based Terminal Programmer's Reference Manual*. Newer models also include a course volume control that is accessible via software.

Optionally, an audio (.wav) decoder can be added to the QTERM-G55 to allow the speaker to play audio files. The audio decoder supports wave files meeting the following criteria:

- Sample rate of 8 kHz, 11.025 kHz, 16 kHz or 22.050 kHz
- Resolution of 8 or 16 bits per sample.

The audio decoder circuit amplifies the signal to 0.5 W rms at the speaker.

3.3.4 Real-Time Clock

The QTERM-G55 terminal can be optionally equipped with a battery-backed, real-time clock. The real-time clock can be used to time/date stamp messages or for timed polling and program execution.

WARNING

There may be danger of leakage if the battery is incorrectly replaced, creating a potential health hazard. Replace the battery only with the same (CR1220) or equivalent type as recommended by the manufacturer. Dispose of used batteries according to the manufacturer's instructions.

3.3.5 System Memory

The QTERM-G55 terminal stores the firmware and user applications in a compressed format in flash memory and then transfers them to RAM memory when the terminal is powered on. Two megabytes of flash memory and sixteen megabytes of RAM memory are standard.

For information on using resources efficiently to conserve memory when creating a user application, refer to “Edit Resources” section in the *Qlarity Foundry User Guide*.

For information on downloading new firmware, downloading a user application, and determining the size of a user application, refer to the *Qlarity Foundry User Guide*.

3.4 Installing to NEMA-4 Specifications

A QTERM-G55 terminal uses a rugged ABS poly carbonate with rubber overmold case designed to mount into a panel. When properly installed in a NEMA-4 rated panel, the QTERM-G55 meets all NEMA-4 specifications including hose-down, icing, and salt spray.

A QTERM-G55 terminal can be installed in either a landscape or portrait orientation. When installing a terminal, you generally take the following steps.

- Decide whether you want to mount and use the terminal in a portrait or landscape orientation. “Portrait” means that the longest dimension is vertical; “landscape” means that the longest dimension is horizontal.
- Cut a hole in the panel. See [section 3.4.1, “Cutout for Panel Mount Configuration”](#) for specifications.
- Install the QTERM-G55 terminal in the panel. See [section 3.4.2, “Installing the Panel Mount Terminal”](#) for instructions.
- Connect cables to the terminal. Verify that the thumb screws are tight or the locks snapped into place for each cable used.
- Apply DC power to the QTERM-G55 terminal. See [section 3.4.3, “Applying Power”](#) for information.

3.4.1 Cutout for Panel Mount Configuration

The QTERM-G55 terminal can be mounted in panels from 0 to 7 mm thick. No screw holes need to be drilled to install the terminal in the panel.

Make a rectangular hole in the panel using the following dimensions.

Horizontal:	117.2 ± 1 mm
Vertical:	212.6 ± 1 mm

File any rough edges smooth, especially on the face of the panel.

Figure 21 is a diagram of the panel mount cutout.

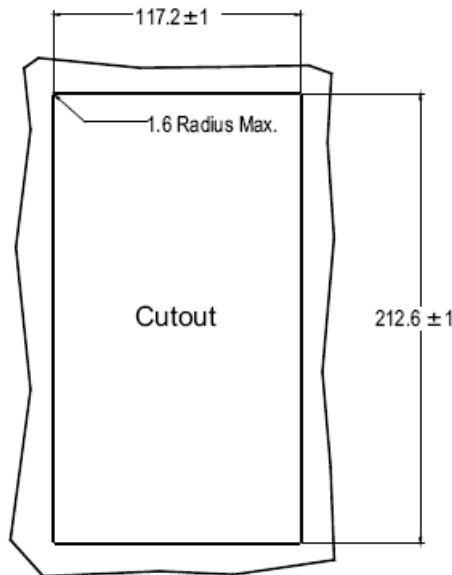



Figure 21
QTERM-G55 Panel Mount Cutout

3.4.2 Installing the Panel Mount Terminal

NOTE  Use of an anti-static strap is recommended when performing installation and maintenance.

Take the following steps to install the terminal. Refer to the illustrations on the next page.

1. Verify that the panel surface around the cutout is clean and free of rough edges. A gasket built into the terminal will seal against this surface. Dirt or imperfections on the panel may prevent a proper seal.
2. Place the terminal into the panel cutout and verify that the terminal is oriented correctly.

3. On the back of the panel, place the terminal mount in bracket against the back of the terminal, and align it with the back panel.
4. Fasten the six screws (supplied with the terminal).

3.4.3 Applying Power

Power is supplied to the QTERM-G55 terminal via the 12-pin round connector (handheld) or the primary serial port connector (panel-mount). Refer to [section 3.2.1, “Handheld Connector Interface”](#) or [section 3.2.2, “Panel-mount Connector Interface”](#) for the pin assignments for power and ground. DC power must be in the range of 8 to 32 volts (the current will vary depending on the input voltage; see following table).

CAUTION



QTERM-G55 power must come from an SELV (Safety Extra Low Voltage) power source and should have a current limit on its output of 5 Amperes. It must provide a minimum of 8 volts DC power and be limited to a maximum of 32 volts DC. Limiting may be inherent to the supply or may be provided by supplementary overcurrent devices. If the QTERM-G55 does not respond or exhibits abnormal behavior on power up, disconnect power and contact Beijer Electronics for technical support.

Current Consumption			
Terminal	12 VDC	24 VDC	PoE
Standard unit (grayscale, no options), idle	120 mA	70 mA	70 mA
Standard TFT unit (color), idle	170 mA	92 mA	90 mA
Standard unit, active	add 90 mA	add 40 mA	add 10 mA
Standard TFT unit (TFT, no options), active	add 90 mA	add 40 mA	add 20 mA
With Ethernet option and connection	add 50 mA	add 20 mA	N/A
Standard unit, sleep mode	12 mA	7 mA	30 mA
Standard TFT unit, sleep mode	60 mA	35 mA	50 mA

3.4.4 Powering On the Terminal for the First Time

When you connect power to the QTERM-G55 terminal, it automatically loads the application saved in flash memory into RAM memory and executes the application. If no application is present, the terminal display may be blank but the backlighting verifies it is powered on.

When you power on the terminal for the first time, a demo application (or a custom application designed for your company) loads. The demo application will help you verify that the terminal is operating properly. Follow the on-screen prompts or any documentation accompanying the program to guide you through tests or demonstrations designed to verify terminal operation.

Once you have verified that the terminal is functioning properly, refer to [Chapter 8, “Power On Setup”](#) for information on configuring your terminal. The Power On Setup utility includes functions to do the following:

- Change orientation of the terminal (portrait or landscape)
- Download a new user application to the terminal
- Select the application mode
- Set up communications settings for the terminal
- Adjust display contrast or backlight
- Enter network (Ethernet) settings
- Enter/change password (if used)
- Set the real-time clock (if available)

4.1 Product Description

The QTERM-G56 is a rugged handheld color LCD graphic terminal with object-based programming. It features a robust list of industrial-grade hardware features and options, including wired Ethernet.

The QTERM-G56 features a QVGA (320x240 pixel) transfective color TFT liquid crystal display (LCD, 256 colors) with integrated 4-wire analog-resistive touch screen. The display includes a light emitting diode (LED) backlight with software-controlled dimming capability. The LED provides reasonable contrast at low power consumption and easy readability. The transfective display provides excellent contrast in sunlight and high ambient light environments.

The QTERM-G56 is equipped with one serial “multiprotocol port,” which is a software-selectable EIA-232/422/485 serial port. The multiprotocol port 485 interface supports software-selectable AC terminations and a fail-safe network, which holds the 485 signal lines in a known state when no transceiver is transmitting. The terminal may optionally include one wired 10/100Base-T Ethernet interface. The QTERM-G56 (without the Ethernet option) includes one EIA-232 serial port with RTS/CTS flow control.

User input occurs through the touch screen and a rugged 24-key or 40-key membrane keypad with steel snap domes. The top row of keys are commonly used as soft keys to navigate through a set of changing menus at the bottom of the display. The standard keypad comes with four or five LEDs under the soft keys that can be used as status or alarm indicators. Power and shift buttons with LEDs are included on both keypad configurations. The power button enables and disables the internal power supply for low power consumption. The terminal may optionally include a software-enabled electroluminescent keypad backlight.

The standard 40-key keypad legend allows for function/soft keys, eight-way directional control and numeric entry in the unshifted mode and alphanumeric data entry in the shifted mode. Keys can perform alternate functions when the shift key is enabled. Both the power and shift functions can be enabled or disabled in software. The keypad legend can be customized with your logo/name and custom keys.

The QTERM-G56 terminal stores the firmware and the user application in a compressed format in flash memory and then transfers them to RAM memory when the terminal is powered on. The terminal is equipped with 4 MB of NOR flash memory (for firmware and application), 32 MB of RAM memory, and 256 MB of internal NAND flash memory for mass storage. The NAND memory is accessible as a FAT-formatted file system both from the application and via the USB device interface (although not simultaneously).

The QTERM-G56 terminal includes a switching power supply with a wide input voltage range of 8 to 32 VDC. Typically, power is supplied through the 12-pin circular push-lock connector or integral cable. The unit may also be powered from a 5 volt USB host port.

Other features include a speaker with software-controlled note pitch, duration, and volume. The terminal may optionally include an audio decoder for .wav file playback. All units feature a real-time clock with one second resolution and battery backup power. The terminal may optionally include an integral cable. Terminals with the integral cable may optionally include a 2-pole, normally closed emergency stop switch.

4.1.1 Specifications

The following tables contain the technical specifications for the QTERM-G56.

TERMINAL DISPLAY	
Active Matrix Color	TFT 256 colors transfective
Pixels	320 x 240
Pixel Pitch	0.2235 mm
Lighting	Light emitting diode brightness is software-controllable
Backlight Brightness	200 cd/m2 typical
Contrast	Transmissive: 150:1 typical
	Reflective: 15:1 typical
TOUCH SCREEN	
Analog-resistive operation	
Transparent touch area over viewable display	
KEYPAD	
24 or 40 keys	
Steel snap domes in membrane	
Lighted keypad with electroluminescent lighting (optional)	
Optional emergency stop switch (2-pole, normally closed; available with integral cable only)	
INTERFACE	
Serial	Software-selectable EIA-232/422/485 serial port with selectable 485 AC terminations and fail-safe network
Serial (second port, without Ethernet option)	EIA-232 serial port with hardware (RTS/CTS) or software (XON/XOFF) handshaking (RTS/CTS not available with integral cable option)
Baud Rates	600 – 115200 bps
Flow control	None XON/XOFF (software) RTS/CTS (hardware)

INTERFACE (continued)	
Data formats	7 or 8 data bits 1 or 2 stop bits Even, odd, or no parity (Development tools support only 8 data bits)
Connector	12-pin round (Hirose HR30-8R-12SC) Integral cable with DB15f (optional)
Ethernet (optional)	10/100Base-T with support for TCP/IP
USB device	USB 2.0 full speed (12 megabits/second) for access to internal NAND flash file system
MEMORY	
Standard	4 MB flash and 32MB SDRAM 256 MB NAND flash accessible as FAT-formatted file system
SPEAKER	
Software programmable pitch and duration	
Audio (.wav) decoder (optional)	
REAL-TIME CLOCK	
Standard	Independent processor-based real-time clock with battery backup, 1 second resolution
PHYSICAL	
Housing	ABS/polycarbonate case with molded rubber boot
Size	129 x 234 x 43 mm
Mass	510 g
Processor	ARM926EJ-S 192 Mhz
ENVIRONMENTAL	
Sealing	NEMA-12 (Standard)
	NEMA-4 (optional)
Temperature	Operating: -20 to 60 °C
	Storage: -40 to 85 °C
Humidity	0 to 95%, non-condensing
Vibration	5 to 2000 Hz, 4 g RMS
Shock	20 g, 6 ms, 6 axis
POWER	
8 to 32 VDC (See section 4.3.7 for current consumption)	
5 VDC USB Host Port	

SOFTWARE	
Programming language	Qlarity (object-based)
Design environment	Qlarity Foundry (Windows)
Command line compiler	Qlarity (Win32 or Linux)
CUSTOMIZING	
Keypad legend	Customize with logo/name or graphics
CERTIFICATION	
FCC Part 15, Class A	
CE Certification	

4.2 Supported Interfaces

4.2.1 Connector Interface

The QTERM-G56 handheld terminal comes with one serial multiprotocol port through a 12-pin round connector (Hirose HR30-8R-12SC) or integral cable with strain relief, terminated with a DB15f connector. The multiprotocol port interface is software-selectable to EIA-232, EIA-422 or EIA-485. The EIA-485 interface includes AC terminations and a fail-safe network, each of which can be set in software. Units without the Ethernet option also include one serial EIA-232 auxiliary port.

EIA-232	with proper cables and grounding the terminal can communicate up to five meters at a top speed of 115,200 bps
EIA-422	permits operation at distances up to 2,000 meters
EIA-485	permits multiple terminals to be connected in a multi-drop chain

Figure 22 shows the handheld unit connector orientation.

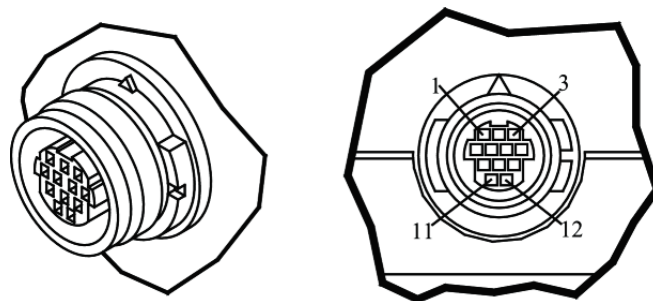

Figure 22
QTERM-G56 Handheld Connector

4.2.1.1 Power and USB Device Interfaces

The following table shows the pinout for the power and USB device interfaces.

Pin	Regulated (standard)	PC USB Host Port
1	8 - 32 VDC	4.5 - 5.5 VDC
2	Ground	Ground
11	N/A	USB D+
12	N/A	USB D-

4.2.1.2 Serial Multiprotocol Port Interface

The following table shows the connector pinout for the selected type of serial interface on the multiprotocol port.

Pin	EIA-232	EIA-422	EIA-485
3	Tx	Tx-	RTx-
4	RTS (out)	Tx+	RTx+
5	Rx	Rx+	No signal
6	CTS (in)	Rx-	No signal

4.2.1.3 Additional Serial Interface (without Ethernet option)

The following table shows the connector pinout for the G56L EIA-232 serial interface.

Pin	EIA-232
7	Tx
8	RTS (out)
9	Rx
10	CTS (in)

4.2.1.4 Network Interface (with Ethernet option)

The following table shows the cable pinout for the 10/100Base-T network interface.

Pin	Ethernet
7	Tx+
8	Tx-
9	Rx+
10	Rx-

4.2.1.5 Accessory Cable Wire Color Code and Demo Cable Pinout

The following table shows the wire color code for the 12-pin round connector to unterminated (“blank”) accessory cable and the pinout to the demo cable, which terminates in a 15-pin female D subminiature connector (DB15f); see [section 4.2.2, “Integral Cable”](#) for a diagram showing the DB15f orientation. The cable contains fifteen conductors; however, only twelve conductors are connected to pins on the round connector and DB15f. Ten of the fifteen conductors in the cable are wired as 100 ohm twisted pairs, as shown in the table. One of the fifteen conductors is a non-insulated drain wire that is shorted to the foil shielding in the cable. This drain wire is not connected to the round connector or DB15f connector.

Round Connector Pin	Wire Color	Twisted Pairs	Demo Cable DB15f Pin
1	Brown	–	9
2	Red with Black Stripe	–	1
3	Black	Pair #1	4
4	White	Pair #1	5
5	Red	Pair #2	10
6	Green	Pair #2	11
7	White with Red Stripe	Pair #3	7
8	White with Green Stripe	Pair #3	14
9	Yellow	Pair #4	6
10	Blue	Pair #4	13
11	Orange	Pair #5	2
12	Gray	Pair #5	3
No Connect	Violet	–	8
No Connect	Green with Black Stripe	–	12
No Connect	Drain	–	15

4.2.2 Integral Cable

The QTERM-G56 can be optionally equipped with an integral cable (instead of the 12-pin round connector). This cable is terminated with a DB15f connector. Figure 23 shows the integral cable connector orientation.

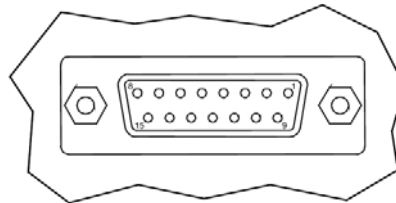

Female DB15 Connector
(End of cable)

Figure 23

QTERM-G56 Integral Cable Connector

4.2.2.1 Power and USB Device Interfaces with Integral Cable

The following table shows the pinout for the power and USB device interfaces when the integral cable option is selected.

DB15f Pin	Regulated (standard)	5 Volt USB Host
9	8 - 32 VDC	4.5 - 5.5 VDC
1	Ground	Ground
2	N/A	USB D+
3	N/A	USB D-

4.2.2.2 Serial Interface with Integral Cable

The following table shows the pinout for the selected typed of serial interface on the multiprotocol port.

DB15f Pin	EIA-232	EIA-422	EIA-485
4	Tx	Tx-	RTx-
5	RTS (out)	Tx+	RTx+
10	Rx	Rx+	No connect
11	CTS (in)	Rx-	No connect

4.2.2.3 Additional Serial Interface with Integral Cable (without Ethernet option)

The following table shows the pinout for the EIA-232 serial interface with integral cable.

Pin	EIA-232
7	Tx
14	RTS (out)
6	Rx
13	CTS (in)

4.2.2.4 Network Interface with Integral Cable (with Ethernet option)

The following table shows the pinout for the 10/100Base-T network interface.

DB15f Pin	Ethernet
7	Tx+
14	Tx-
6	Rx+
13	Rx-

4.2.2.5 E-stop Option with Integral Cable

If the terminal is equipped with the E-stop option (which requires the integral cable), the DB15f pinout changes to accommodate the switch signals, as shown below.

4.2.2.6 Power and USB Device Interfaces with E-stop Option and Integral Cable

The following table shows the pinout for the power and USB device interfaces when the E-stop option and integral cable are selected.

DB15f Pin	Regulated (standard)	5 Volt USB Host
9	8 - 32 VDC	4.5 - 5.5 VDC
1	Ground	Ground
2	N/A	USB D+
3	N/A	USB D-

4.2.2.7 Serial Interface with E-Stop Option and Integral Cable (without Ethernet option)

The following table shows the pinout for the selected typed of serial interface on the multiprotocol port with integral cable and E-stop option.

DB15f	EIA-232	EIA-422	EIA-485
4	Tx	Tx-	Rtx-
14	RTS (out)	Tx+	Rtx+
10	Rx	Rx+	No connect
13	CTS (in)	Rx-	No connect

4.2.2.8 Additional Serial Interface with E-Stop Option and Integral Cable (without Ethernet option)

The following table shows the pinout for the EIA-232 serial interface with integral cable and E-stop option.

Pin	EIA-232
7	Tx
6	Rx

4.2.2.9 Network Interface with E-Stop Option and Integral Cable (with Ethernet option)

The following table shows the pinout for the 10/100Base-T network interface with integral cable and E-stop option.

DB15f Pin	Ethernet
7	Tx+
14	Tx-
6	Rx+
13	Rx-

4.2.2.10 Serial Interface with E-stop Option and Integral Cable (with Ethernet option)

The following table shows the pinout for each type of serial or network interface.

DB15f Pin	EIA-232
4	Tx
10	Rx

NOTE  Due to pin constraints, the EIA-422 and EIA-485 multiprotocol serial port interfaces are not available with the E-stop/integral cable/Ethernet options, and the EIA-232 interface does not have RTS/CTS flow control. The terminal should be set in software or Power On Setup to EIA-232 only with no hardware handshaking

4.2.2.11 E-stop Switch Interface with Integral Cable

The following table shows the integral cable pinout for the two-pole normally closed E-stop switch. The conductors for each pole (Pole 1 and Pole 2) of the switch are shorted until the switch is activated. After activation, each pole is an open circuit until the switch is reset.

DB15f Pin	E-stop Switch
5	Pole 1
8	Pole 1
11	Pole 2
12	Pole 2

4.2.2.12 Integral Cable Wire Color Code

The following table shows the wire color code for the DB15f connector on the integral cable; this information is provided to facilitate removal of the DB15f if desired. Ten of the fifteen conductors in the cable are wired as 100 ohm twisted pairs, as shown in the table. One of the fifteen conductors is a non-insulated drain wire that is shorted to the foil shielding in the cable.

DB15f Pin	Wire Color	Twisted Pairs
1	Red with Black Stripe	–
2	Orange	Pair #5
3	Gray	Pair #5
4	Black	Pair #1
5	White	Pair #1
6	Yellow	Pair #4
7	White with Red Stripe	Pair #3
8	Violet	–
9	Brown	–
10	Red	Pair #2
11	Green	Pair #2
12	Green with Black Stripe	–
13	Blue	Pair #4
14	White with Green Stripe	Pair #3
15	Violet	–

4.3 Terminal Components

4.3.1 Display

The standard QTERM-G56 features a QVGA (320x240 pixel) transfective color TFT LCD (256 colors). The display includes a light emitting diode (LED) backlight with software-controlled dimming capability. The LED backlight provides reasonable contrast at low power consumption and easy readability. The transfective display provides excellent contrast in sunlight and high ambient light environments. Refer to Figure 24.

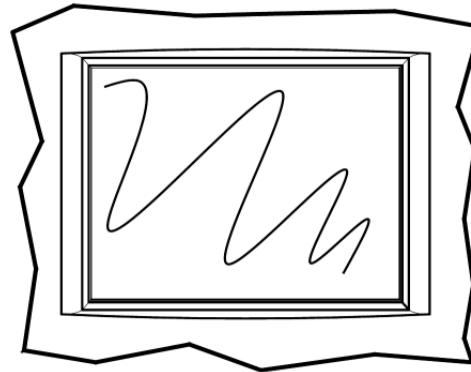

Figure 24
QTERM-G56 Display

4.3.2 Touch Screen

The QTERM-G56 touch screen provides user input through any number of touch keys located on the display. Touch keys can be defined in your user applications at any location on the display and may be any size. Most visible objects in the Qlarity Object libraries are inherently touch-sensitive. The touch screen functionality can also be enabled or disabled in software (either in the user application or via the Power On Setup utility).

4.3.3 Keypad

User input also occurs through a rugged 24-key or 40-key membrane keypad with steel snap domes. The top row of keys are commonly used as soft keys to navigate through a set of changing menus at the bottom of the display. The standard keypad comes with four or five LEDs under the soft keys that can be used as status or alarm indicators. Power and shift buttons with LEDs are included on both keypad configurations. The power button enables and disables the internal power supply for true shutdown.

The standard 40-key keypad legend allows for function / soft keys, eight-way directional control and numeric entry in the unshifted mode and alphanumeric data entry in the shifted mode. Keys can perform alternate functions when the shift key is enabled. The power and shift functions can be enabled or disabled in software.

The keypad legend can be customized with your logo/name and custom keys.

4.3.4 Speaker

A speaker is built into the QTERM-G56 terminal and faces to the back of the unit. Audio can be linked to events or actions (e.g., key press, timer, etc.). Pitch and duration of a note are controlled by API functions called from the user application. Refer to the “Controlling the Speaker” section in the *Qlarity-based Terminal Programmer’s Reference Manual*. Volume control is also accessible via software.

The terminal may optionally include an audio decoder that allows the terminal to play PCM audio (.wav) files. The audio decoder supports wave files meeting the following criteria:

- Sample rate of 8 kHz, 11.025 kHz, 16 kHz or 22.050 kHz
- Resolution of 8 or 16 bits per sample.

4.3.5 Real-Time Clock

The QTERM-G56 terminal includes a battery-backed real-time clock. The real-time clock can be used to time/date stamp messages or for timed polling and program execution.

WARNING



There may be danger of leakage if the battery is incorrectly replaced, creating a potential health hazard. Replace the battery only with the same (CR2032) or equivalent type as recommended by the manufacturer. Dispose of used batteries according to the manufacturer's instructions.

4.3.6 System Memory

The QTERM-G56 terminal stores the firmware and user applications in a compressed format in flash memory and then transfers them to RAM memory when the terminal is powered on. Four MB of flash memory and 32 MB of RAM memory are standard.

For information on using resources efficiently to conserve memory when creating a user application, refer to the “Edit Resources” section in the *Qlarity Foundry User Guide*.

For information on downloading new firmware, downloading a user application, and determining the size of a user application, refer to the *Qlarity Foundry User Guide*.

The QTERM-G56 also includes 256 MB of internal NAND flash which is accessible as a FAT-formatted file system both from the application and the USB device port (but not simultaneously). Refer to [section 4.4.1](#) for information on accessing the internal flash memory using the USB device port.

4.3.7 Applying Power

Power is supplied to the QTERM-G56 terminal via the 12-pin round connector or integral cable. DC power must be in the range of 8 to 32 volts (the current will vary depending on the input voltage; see the following table).

CAUTION



QTERM-G56 power must come from an SELV (Safety Extra Low Voltage) power source and should have a current limit on its output of 5 Amperes. It must provide a minimum of 8 volts DC power and be limited to a maximum of 32 volts DC. Limiting may be inherent to the supply or may be provided by supplementary overcurrent devices. If the QTERM-G56 does not respond or exhibits abnormal behavior on power up, disconnect power and contact Beijer Electronics for technical support.

Current Consumption		
Terminal	12 VDC	24 VDC
Power off	2 mA	5 mA
Idle	75 mA	50 mA
Ethernet option, active	155 mA	90 mA
Ethernet option, idle	130 mA	80 mA
Active	200 mA	115 mA
EL Keypad Backlight	add 10 mA	add 6 mA

4.4 Powering On the Terminal for the First Time

When you connect power to the QTERM-G56 terminal, the unit will remain unpowered until you press the power button on the keypad. The unit is turned on or off by pressing the power button. When the unit is powered on, it automatically loads the application saved in flash memory into RAM memory and executes the application. If no application is present, the Application Loader banner should appear on the display.

When you power on the terminal for the first time, a demo application (or a special application custom designed for your company) automatically loads. The demo application will help you verify that the terminal is operating properly. Follow the on-screen prompts or any documentation accompanying the program to guide you through tests or demonstrations designed to verify terminal operation.

Once you have verified that the terminal is functioning properly, refer to [Chapter 8, “Power On Setup”](#) for information on configuring your terminal. The Power On Setup utility includes functions to do the following:

- Change orientation of the terminal display (portrait or landscape)
- Download a new user application to the terminal

- Select the application mode
- Set up communications settings for the terminal
- Adjust display backlight
- Enter network (Ethernet) settings
- Enter/change password (if used)
- Set the real-time clock
- Set speaker volume
- Adjust settings for the keypad and keypad backlight (if available)

4.4.1 Accessing The Internal Mass Storage Via USB

The QTERM-G56 includes internal NAND flash for mass storage. This storage memory is accessible from both the application and the USB device interface, where it appears as a FAT-formatted file system to the USB host.

To access the internal mass storage via USB, connect the terminal to a PC or other USB host using the QTERM-G56 Programming Cable accessory. The USB host will enumerate the terminal, which should appear as a removable disk mounted to the host's file system. The file system may take several seconds to become available for viewing or modification. Files may be stored or retrieved using file access software on the PC, as with any USB mass storage device.

Note that many operating systems recommend or require that a USB removable disk be ejected before it is removed. See the documentation for your PC operating system for more details.

5.1 Product Description

The QTERM-G58 is a rugged handheld color LCD graphic terminal with object-based programming. It features a robust list of industrial-grade hardware features and options, including wireless (802.11b/g) Ethernet and battery power.

The QTERM-G58 features a QVGA (320x240 pixel) transfective color TFT liquid crystal display (LCD, 256 colors) with integrated 4-wire analog-resistive touch screen. The display includes a light emitting diode (LED) backlight with software-controlled dimming capability. The LED provides reasonable contrast at low power consumption and easy readability. The transfective display provides excellent contrast in sunlight and high ambient light environments.

The QTERM-G58 is equipped with one serial “multiprotocol port,” which is a software-selectable EIA-232/422/485 serial port. The multiprotocol port 485 interface supports software-selectable AC terminations and a fail-safe network, which holds the 485 signal lines in a known state when no transceiver is transmitting. The G58 also integrates an internal lithium-polymer battery pack for portable operation. The G58 may optionally include an 802.11b/g wireless Ethernet interface.

User input occurs through the touch screen and a rugged 24-key or 40-key membrane keypad with steel snap domes. The top row of keys are commonly used as soft keys to navigate through a set of changing menus at the bottom of the display. The standard keypad comes with four or five LEDs under the soft keys that can be used as status or alarm indicators. Power and shift buttons with LEDs are included on both keypad configurations. The power button enables and disables the internal power supply for low power consumption (and extended battery life). The terminal may optionally include a software-enabled electroluminescent keypad backlight.

The standard 40-key keypad legend allows for function / soft keys, eight-way directional control and numeric entry in the unshifted mode and alphanumeric data entry in the shifted mode. Keys can perform alternate functions when the shift key is enabled. Both the power and shift functions can be enabled or disabled in software.

The keypad legend can be customized with your logo/name and custom keys.

The QTERM-G58 terminal stores the firmware and the user application in a compressed format in flash memory and then transfers them to RAM memory when the terminal is powered on. The G58 is equipped with 4 MB of NOR flash memory (for firmware and application), 32 MB of RAM memory, and 256 MB of internal NAND flash memory for mass storage. The NAND memory is accessible as a FAT-formatted file system both from the application and via the USB device interface (although not simultaneously).

The QTERM-G58 terminal includes a switching power supply with a wide input voltage range of 8 to 32 VDC. Typically, power is supplied through the 12-pin circular push-lock connector or integral cable. The unit may also be powered from a 5 volt USB host port – in this case, the optional 802.11b/g wireless Ethernet interface is not accessible due to USB power supply limitations.

Other features include a speaker with software-controlled note pitch, duration, and volume. The terminal may optionally include an audio decoder for .wav file playback. All units feature a real-time clock with one second resolution and battery backup power.

5.1.1 Specifications

The following tables contain the technical specifications for the QTERM-G58.

TERMINAL DISPLAY	
Active Matrix Color	TFT 256 colors transfective
Pixels	320 x 240
Pixel Pitch	0.2235 mm
Lighting	Light emitting diode brightness is software-controllable
Backlight Brightness	200 cd/m ² typical
Contrast	Transmissive: 150:1 typical
	Reflective: 15:1 typical
TOUCH SCREEN	
Analog-resistive operation	
Transparent touch area over viewable display	
KEYPAD	
24 or 40 keys	
Steel snap domes in membrane	
Lighted keypad with electroluminescent lighting (optional)	
INTERFACE	
Serial	Software-selectable EIA-232/422/485 serial port with selectable 485 AC terminations and fail-safe network
Baud Rates	600 – 115200 bps
Flow control	None XON/XOFF (software) RTS/CTS (hardware)

INTERFACE (continued)	
Data formats	7 or 8 data bits 1 or 2 stop bits Even, odd, or no parity (Development tools support only 8 data bits)
Connector	12-pin round (Hirose HR30-8R-12SC)
Wireless Ethernet (optional)	802.11b/g Infrastructure or Ad Hoc mode Encryption: 128-bit WEP, WPA, WPA2 (TKIP/AES) Dual internal antennas for receive diversity
USB device	USB 2.0 full speed (12 megabits/second) for access to internal NAND flash file system
MEMORY	
Standard	4 MB flash and 32MB SDRAM 256 MB NAND flash accessible as FAT-formatted file system
SPEAKER	
Software programmable pitch and duration	
Audio (.wav) decoder (optional)	
REAL-TIME CLOCK	
Standard	Independent processor-based real-time clock with battery backup, 1 second resolution
PHYSICAL	
Housing	ABS/polycarbonate case with molded rubber boot
Size	129 x 234 x 50 mm
Mass	650 g
Processor	ARM926EJ-S 192 Mhz
ENVIRONMENTAL	
Sealing	NEMA-4
Temperature	Operating: -20 to 60 °C (-20 to 55 °C with Wireless Ethernet option)
	Storage: -40 to 85 °C
	Battery charge: 0 to 40 °C
Humidity	0 to 95%, non-condensing
Vibration	5 to 2000 Hz, 4 g RMS
Shock	20 g, 6 ms, 6 axis

POWER	
8 to 32 VDC (See section 5.3.7 for current consumption)	
5 VDC USB Host Port (Wireless Ethernet disabled)	
SOFTWARE	
Programming language	Qlarity (object-based)
Design environment	Qlarity Foundry (Windows)
Command line compiler	Qlarity (Win32 or Linux)
CUSTOMIZING	
Keypad legend	Customize with logo/name or graphics
CERTIFICATION	
FCC Part 15, Class A	
CE Certification	

5.2 Supported Interfaces

5.2.1 Connector Interface

The QTERM-G58 handheld terminal comes with one serial multiprotocol port through a 12-pin round connector (Hirose HR30-8R-12SC). The multiprotocol port interface is software-selectable to EIA-232, EIA-422 or EIA-485. The EIA-485 interface includes AC terminations and a fail-safe network, each of which can be set in software.

EIA-232	with proper cables and grounding the terminal can communicate up to five meters at a top speed of 115,200 bps
EIA-422	permits operation at distances up to 2,000 meters
EIA-485	permits multiple terminals to be connected in a multi-drop chain

Figure 25 shows the handheld unit connector orientation.

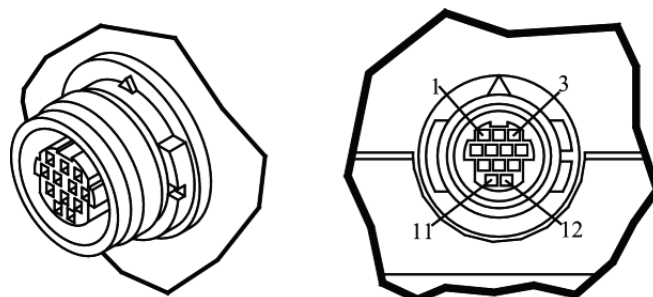

Figure 25
QTERM-G58 Handheld Connector

5.2.1.1 Power and USB Device Interfaces

The following table shows the pinout for the power and USB device interfaces.

Pin	Regulated (standard)	PC USB Host Port
1	8 - 32 VDC	4.5 - 5.5 VDC
2	Ground	Ground
11	N/A	USB D+
12	N/A	USB D-

5.2.1.2 Serial Multiprotocol Port Interface

The following table shows the connector pinout for the selected type of serial interface on the multiprotocol port.

Pin	EIA-232	EIA-422	EIA-485
3	Tx	Tx-	RTx-
4	RTS (out)	Tx+	RTx+
5	Rx	Rx+	No signal
6	CTS (in)	Rx-	No signal

5.2.1.3 Accessory Cable Wire Color Code and Demo Cable Pinout

The following table shows the wire color code for the 12-pin round connector to unterminated (“blank”) accessory cable and the pinout to the demo cable, which terminates in a 15-pin female D subminiature connector (DB15f). The cable contains fifteen conductors; however, only twelve conductors are connected to pins on the round connector and DB15f. Ten of the fifteen conductors in the cable are wired as 100 ohm twisted pairs, as shown in the table. One of the fifteen conductors is a non-insulated drain wire that is shorted to the foil shielding in the cable. This drain wire is not connected to the round connector or DB15f connector.

Round Connector Pin	Wire Color	Twisted Pairs	Demo Cable DB15f Pin
1	Brown	–	9
2	Red with Black Stripe	–	1
3	Black	Pair #1	4
4	White	Pair #1	5
5	Red	Pair #2	10
6	Green	Pair #2	11
7	White with Red Stripe	Pair #3	7
8	White with Green Stripe	Pair #3	14

Round Connector Pin	Wire Color	Twisted Pairs	Demo Cable DB15f Pin
9	Yellow	Pair #4	6
10	Blue	Pair #4	13
11	Orange	Pair #5	2
12	Gray	Pair #5	3
No Connect	Violet	–	8
No Connect	Green with Black Stripe	–	12
No Connect	Drain	–	15

5.3 Terminal Components

5.3.1 Display

The standard QTERM-G58 features a QVGA (320x240 pixel) transfective color TFT LCD (256 colors). The display includes a light emitting diode (LED) backlight with software-controlled dimming capability. The LED backlight provides reasonable contrast at low power consumption and easy readability. The transfective display provides excellent contrast in sunlight and high ambient light environments. Refer to Figure 26.

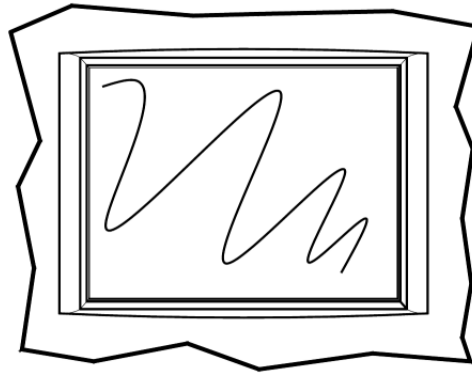

Figure 26
QTERM-G58 Display

5.3.2 Touch Screen

The QTERM-G58 touch screen provides user input through any number of touch keys located on the display. Touch keys can be defined in your user applications at any location on the display and may be any size. Most visible objects in the Qlarity Object libraries are inherently touch-sensitive. The touch screen functionality can also be enabled or disabled in software (either in the user application or via the Power On Setup utility).

5.3.3 Keypad

User input occurs through a rugged 24-key or 40-key membrane keypad with steel snap domes. The top row of keys are commonly used as soft keys to navigate through a set of changing menus at the bottom of the display. The standard keypad comes with four or five LEDs under the soft keys that can be used as status or alarm indicators. Power and shift buttons with LEDs are included on both keypad configurations. The power button enables and disables the internal power supply for true shutdown.

The standard 40-key keypad legend allows for function/soft keys, eight-way directional control and numeric entry in the unshifted mode and alphanumeric data entry in the shifted mode. Keys can perform alternate functions when the shift key is enabled. The power and shift functions can be enabled or disabled in software.

The keypad legend can be customized with your logo/name and custom keys.

5.3.4 Speaker

A speaker is built into the QTERM-G58 terminal and faces to the back of the unit. Audio can be linked to events or actions (e.g., key press, timer, etc.). Pitch and duration of a note are controlled by API functions called from the user application. Refer to the “Controlling the Speaker” section in the *Qlarity-based Terminal Programmer’s Reference Manual*. Volume control is also accessible via software.

The terminal may optionally include an audio decoder that allows it to play PCM audio (.wav) files. The audio decoder supports wave files meeting the following criteria:

- Sample rate of 8 kHz, 11.025 kHz, 16 kHz or 22.050 kHz
- Resolution of 8 or 16 bits per sample.

5.3.5 Real-Time Clock

The QTERM-G58 terminal includes a battery-backed real-time clock. The real-time clock can be used to time/date stamp messages or for timed polling and program execution.

WARNING



There may be danger of leakage if the battery is incorrectly replaced, creating a potential health hazard. Replace the battery only with the same (CR2032) or equivalent type as recommended by the manufacturer. Dispose of used batteries according to the manufacturer’s instructions.

5.3.6 System Memory

The QTERM-G58 terminal stores the firmware and user applications in a compressed format in flash memory and then transfers them to RAM memory when the terminal is powered on. Four MB of flash memory and 32 MB of RAM memory are standard.

For information on using resources efficiently to conserve memory when creating a user application, refer to the “Edit Resources” section in the *Qlarity Foundry User Guide*.

For information on downloading new firmware, downloading a user application, and determining the size of a user application, refer to the *Qlarity Foundry User Guide*.

The QTERM-G58 also includes 256 MB of internal NAND flash which is accessible as a FAT-formatted file system both from the application and the USB device port (but not simultaneously). Refer to [section 5.4.2](#) for information on accessing the internal flash memory using the USB device port.

5.3.7 Applying Power

Power is supplied to the QTERM-G58 terminal via the 12-pin round connector or integral cable. DC power must be in the range of 8 to 32 volts (the current will vary depending on the input voltage; see the following table).

CAUTION



QTERM-G58 power must come from an SELV (Safety Extra Low Voltage) power source and should have a current limit on its output of 5 Amperes. It must provide a minimum of 8 volts DC power and be limited to a maximum of 32 volts DC. Limiting may be inherent to the supply or may be provided by supplementary overcurrent devices. If the QTERM-G58 does not respond or exhibits abnormal behavior on power up, disconnect power and contact Beijer Electronics for technical support.

Current Consumption			
Terminal	12 VDC	24 VDC	Battery
Power off	2 mA	5 mA	—
Idle	100 mA	65 mA	110 mA
Active	180 mA	100 mA	195 mA
Charging	add 1200 mA max	—	—
Wireless Ethernet	add 95 mA	add 50 mA	add 125 mA
EL Keypad Backlight	add 10 mA	add 6 mA	add 13 mA

5.4 Powering On the Terminal for the First Time

When you connect power to the QTERM-G58 terminal, the unit will remain unpowered until you press the power button on the keypad. The unit is turned on or off by pressing the power button. When the unit is powered on, it automatically loads the application saved in flash memory into RAM memory and executes the application. If no application is present, the Application Loader banner should appear on the display.

When you power on the terminal for the first time, a demo application (or a special application custom designed for your company) automatically loads. The demo application will help you verify that the terminal is operating properly. Follow the on-screen prompts or any documentation accompanying the program to guide you through tests or demonstrations designed to verify terminal operation.

Once you have verified that the terminal is functioning properly, refer to [Chapter 8, “Power On Setup”](#) for information on configuring your terminal. The Power On Setup utility includes functions to do the following:

- Change orientation of the terminal display (portrait or landscape)
- Download a new user application to the terminal
- Select the application mode
- Set up communications settings for the terminal
- Adjust display backlight
- Enter network (Wireless Ethernet) settings
- Enter/change password (if used)
- Set the real-time clock
- Set speaker volume
- Adjust settings for the keypad and keypad backlight (if available)

5.4.1 Powering and Charging the Battery Powered QTERM-G58

WARNING

The QTERM-G58 internal battery pack is not user-serviceable. Contact Beijer Electronics for battery service or replacement.
DO NOT attempt to remove the battery pack from the terminal housing.
DO NOT puncture, bend, or place mechanical strain on the battery pack.
DO NOT attempt to charge the battery pack by any means other than the battery charge circuitry included on the QTERM-G58 circuit board.

The QTERM-G58 includes an internal rechargeable battery pack for untethered operation. Press the power button on the keypad to power the terminal on and off. The Qlarity Object

Library contains objects to indicate the current charge level of the battery, power source (external or battery), and other information. Refer to the Qlarity Foundry documentation for details.

Power (8 to 32 VDC) may be connected to the G58 terminal at any time. When external power is detected, the terminal will use external power instead of the battery for operation.

The internal battery is charged by connecting a 12 VDC supply and ground to the power pins of the terminal. Beijer Electronics offers charging cable accessories for standard AC mains power (with optional international plug kit) and a vehicle cigarette lighter adapter. If the terminal is powered off at connection, the power and shift LEDs on the keypad will light, and the display will show a battery charging icon. The icon and shift LED will flash during charging. A continuously lit shift LED and static battery icon on the display indicate that charging is complete. If the unit is powered on when the charge power supply is connected, the application can detect and indicate charge status if desired.

5.4.2 Accessing The Internal Mass Storage Via USB

The QTERM-G58 includes internal NAND flash for mass storage. This storage memory is accessible from both the application and the USB device interface, where it appears as a FAT-formatted file system to the USB host.

To access the internal mass storage via USB, connect the terminal to a PC or other USB host using the QTERM-G58 Programming Cable accessory. The USB host will enumerate the terminal, which should appear as a removable disk mounted to the host's file system. The file system may take several seconds to become available for viewing or modification. Files may be stored or retrieved using file access software on the PC, as with any USB mass storage device.

Note that many operating systems recommend or require that a USB removable disk be ejected before it is removed. See the documentation for your PC operating system for more details.

NOTE  *The QTERM-G58 terminal is a self-powered USB device and draws negligible power from the USB bus. Battery drain is comparable to untethered operation.*

QTERM-Z60 TERMINAL

6.1 Product Description

The QTERM-Z60 terminal is an economical graphic terminal with object-based programming. Two different models of the QTERM-Z60 exist to suit any environment and budget. In general, the Z60/H version is NEMA-4 rated and has a user-selectable serial port while the Z60/L is NEMA-12 rated, has one EIA-232 serial port and a slightly different display.

The QTERM-Z60 features a QVGA, 320x240 pixel, 256 color STN color LCD display. It uses a cold-cathode fluorescent backlight (CCFL). The CCFL provides high contrast and easy readability and is replaceable. The contrast is software controlled and temperature compensated. The analog-resistive touch screen covers the full viewable area of the display as well as the pre-labeled legend underlay around the display.

The QTERM-Z60/H is equipped with one user-selectable serial port (EIA-232, EIA-422, or EIA-485). The interface is selected using DIP switches. The QTERM-Z60/L is equipped with one EIA-232 serial port.

A speaker, which has programmable pitch and duration, comes standard as does a 5 VDC 200 mA output from the interface connector to power external devices. An external reset signal also comes standard to allow other devices to reset the QTERM-Z60.

The QTERM-Z60 terminal stores firmware and user applications in a compressed format in flash memory and then transfers them to RAM memory when the terminal is powered on. The terminal is equipped with two megabytes of flash memory and sixteen megabytes of RAM memory.

The QTERM-Z60 terminal requires a DC power source ranging from 8 to 32 VDC. This power is supplied via the main interface connector.

6.1.1 Specifications

The following tables contain the technical specifications for the QTERM-Z60.

TERMINAL DISPLAY	
Standard	STN 256 colors
Pixels	320 x 240
Dot Pitch	0.36 mm
Contrast	Software controlled, temperature compensated

TERMINAL DISPLAY	
Lighting	Cold-cathode fluorescent, brightness is software-controllable
Backlight Brightness	200 nits typical
TOUCH SCREEN	
Analog-resistive operation	
Transparent touch area over viewable display	
Labeled touch underlay area on each side of display	
INTERFACE	
Z60/H	EIA-232, -422 or -485 serial port
Z60/L	EIA-232 serial port
Baud rates	600 – 115,200 bps
Data formats	7 or 8 data bits 1 or 2 stop bits Even, odd, or no parity (PC Tools supports only 8 data bits)
Connector	Molex 43045-1218
Mating Connector	Molex 43025-1200
Mating Connector Pins	Molex 43030-0001
MEMORY	
Standard	2 Mbytes flash and 16 Mbytes SDRAM
SPEAKER	
Standard	Software programmable pitch and duration
PHYSICAL	
Configuration	Panel-mount
Housing	Glass-filled polyester, UL 94V-0 flame rating, accommodates panels from 0 to 7 mm thick with standard screws
Size	215 x 161 x 50 mm
Weight	0.98 kg
Processor	ARM 720T 77 MHz
ENVIRONMENTAL	
QTERM-Z60/H Sealing	NEMA-4 front panel
QTERM-Z60/L Sealing	NEMA-12/13 front panel
Temperature	Operating: 0 to 50 °C Storage: -10 to 60 °C
Humidity	0 to 95%, non-condensing

ENVIRONMENTAL	
Vibration	5 to 5000 Hz, 4 g RMS
Shock	20 g, 3 ms, any axis
POWER	
8 to 32 VDC (See section 6.4.3 for current consumption)	
SOFTWARE	
Programming language	Qlarity (object-based)
Design environment	Qlarity Foundry (Windows)
Command line compiler	Qlarity (Win32 or Linux)
CERTIFICATION	
FCC Part 15, Class A CE Certification	

6.2 Supported Interfaces

6.2.1 Serial Ports

The QTERM-Z60/H comes standard with one user-selectable serial port. The serial port interface can be selected via dip switches (EIA-232, EIA-422 or EIA-485). The QTERM-Z60/L is equipped with one EIA-232 serial port.

NOTE  *The serial port is wired as Data Communications Equipment (DCE)*

The interface is selected using DIP switches. The following table shows the dip switch settings.

Dip Switch Settings								
	1	2	3	4	5	6	7	8
EIA-232	off	off	off	off	off	on	off	off
EIA-422	off	off	off	off	on	off	off	off
EIA-485	on	on	on	on	on	off	off	off

Figure 27 shows the serial connector's orientation.

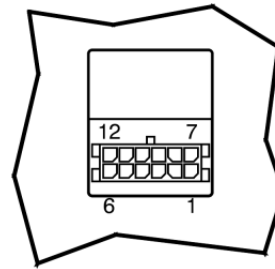

Connector Detail
(Back of Unit)

Figure 27
QTERM-Z60 Serial Connector

EIA-232	with proper cables and grounding the terminal can communicate up to five meters at a top speed of 115,200 bps
EIA-422	permits operation at distances up to 2,000 meters
EIA-485	permits multiple terminals to be connected in a multi-drop chain

The following table shows the pinouts for the interface connector.

Pin	Function
1	Power In
2	RS-232 TX (out)
3	EIA-422 TX+ (out)
4	EIA-422 RX+ (in), or EIA-485 RTX+
5	5 VDC output
6	No Connect
7	Ground
8	RS-232 RX (in)
9	EIA-422 TX- (out)
10	EIA-422 RX- (in), or EIA-485 RTX-
11	External Reset (in)
12	No Connect

6.2.2 Five Volt Power Supply Output

Pin 5 of the interface connector is a 5 VDC power supply and can supply up to 200 mA current to a serial peripheral device (such as a barcode reader). The ground return for the supply is on pin 7 of the interface connector.

6.2.3 External Reset Input

Pin 11 of the interface connector is a reset signal compatible with 5 VDC and 3.3 VDC logic signals. By applying a 3.3 VDC or 5 VDC pulse to this input, the terminal will perform a complete hardware reset.

6.3 Terminal Components

6.3.1 Touch Screen

The QTERM-Z60 touch screen provides user input through any number of touch keys located on or around the display. The standard key legend shown in Figure 28 provides areas for five soft keys down each side of the display. A custom legend underlay can be ordered to personalize the terminal for your application for shipments of over one hundred.

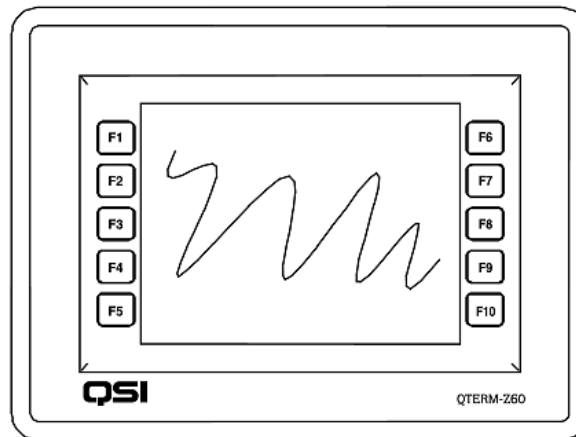

Figure 28
QTERM-Z60 Display

Touch keys can also be defined in your user applications at any location on or around the display. Touch keys may be any size.

6.3.2 Speaker

A speaker is built into the QTERM-Z60 terminal and faces to the back of the unit. Audio can be linked to events or actions (e.g., screen press, timer, etc.). Pitch and duration are controlled by API functions called from the user application. Refer to the “Controlling the Speaker” section in the *Qlarity-based Terminal Programmer's Reference Manual*.

6.3.3 System Memory

The QTERM-Z60 terminal stores the firmware and user applications in a compressed format in flash memory and then transfers them to RAM memory when the terminal is powered on. Two megabytes of flash memory and sixteen megabytes of RAM memory are standard.

For information on using resources efficiently to conserve memory when creating a user application, refer to the “Edit Resources” section in the *Qlarity Foundry User Guide*.

For information on downloading new firmware, downloading a user application, and determining the size of a user application, refer to the *Qlarity Foundry User Guide*.

6.4 Installing to NEMA-4 Specifications

A QTERM-Z60 terminal uses a rugged, glass-filled polyester (UL 94V-0) case designed to mount into a panel. When properly installed in a NEMA-4 rated panel, the QTERM-Z60 meets all NEMA-4 specifications including hose-down, icing, and salt spray.

A QTERM-Z60 terminal can be installed in either a landscape or portrait orientation. When installing a terminal, you generally take the following steps.

- Decide whether you want to mount and use the terminal in a portrait or landscape orientation. “Portrait” means that the longest dimension is vertical; “landscape” means that the longest dimension is horizontal.
- Cut a hole in the panel See [section 6.4.1, “Cutting Out the Panel”](#) for specifications.
- Install the QTERM-Z60 terminal in the panel. See [section 6.4.2, “Installing the Terminal”](#) for instructions.
- Connect cables to the terminal. Verify that the thumb screws are tight or the locks snapped into place for each cable used.

Apply DC power to the QTERM-Z60 terminal See [section 6.4.3, “Applying Power”](#) for information.

6.4.1 Cutting Out the Panel

The QTERM-Z60 terminal can be mounted in panels from 0 to 7 mm thick. No screw holes need to be drilled to install the terminal in the panel.

Make a rectangular hole in the panel using the following dimensions.

Landscape	Portrait
Horizontal: 199 ± 1 mm	Horizontal: 145 ± 1 mm
Vertical: 145 ± 1 mm	Vertical: 199 ± 1 mm

Figure 29 is a diagram of the landscape cutout.

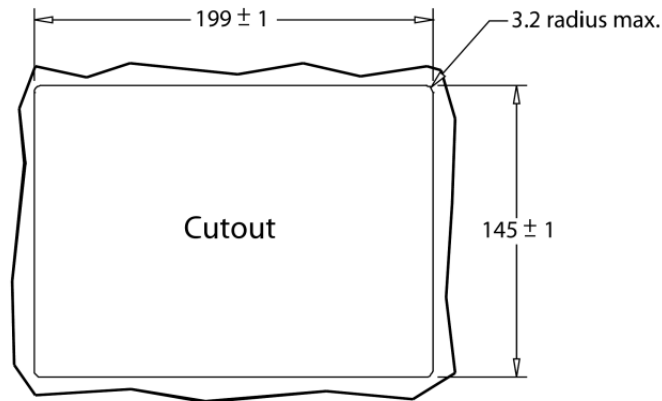



Figure 29
QTERM-Z60 Landscape Cutout

File any rough edges smooth, especially on the face of the panel.

6.4.2 Installing the Terminal

NOTE  Use of an anti-static strap is recommended when performing installation and maintenance.

Take the following steps to install the terminal.

1. Verify that the panel surface around the cutout is clean and free of rough edges. A gasket built into the terminal will seal against this surface. Dirt or imperfections on the panel may prevent a proper seal.
2. Place the terminal into the panel cutout and verify that the terminal is oriented correctly. The touch screen legend may indicate the orientation. If not, you can determine which side should be at the top by the position of the serial port on the back panel as follows:
 - Landscape
When looking at the front of the unit, the back panel serial port should be on the top of the terminal.
 - Portrait
When looking at the front of the unit, the back panel serial port should be on the right side of the terminal.

Refer to [Figure 30](#).

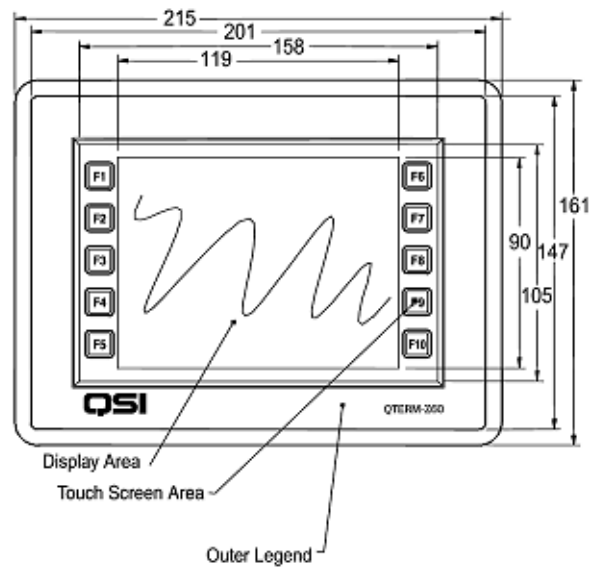

Figure 30
QTERM-Z60 Front Panel Mount

3. On the back of the panel, place the terminal mounting bracket against the back of the terminal, and align it with the back panel. Refer to Figure 31.

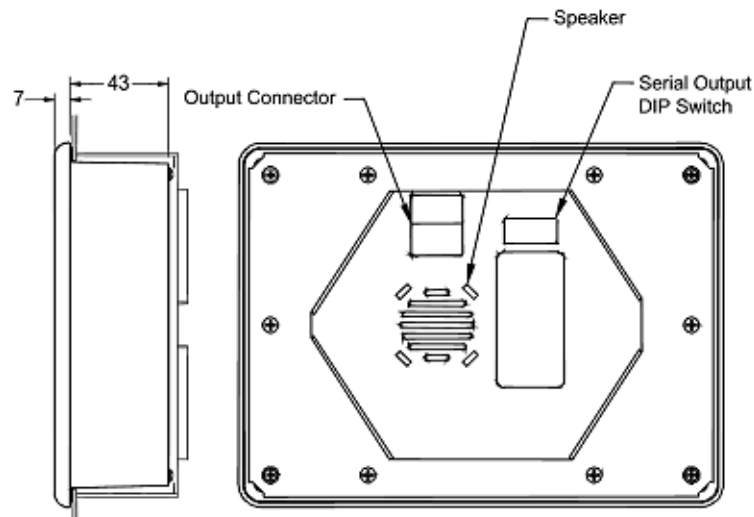

Figure 31
QTERM-Z60 Back Panel Mount

4. Fasten the six screws (supplied with the terminal).

6.4.3 Applying Power

Power is supplied to the QTERM-Z60 terminal via the interface connector. Refer to [section 6.2.1, “Serial Ports”](#) for the pin assignments for power and ground. DC power must be

in the range of 8 to 32 volts (the current will vary depending on the input voltage; see table that follows).

CAUTION



QTERM-Z60 power must come from an SELV (Safety Extra Low Voltage) power source and should have a current limit on its output of 5 Amperes. It must provide a minimum of 8 volts DC power and be limited to a maximum of 32 volts DC. Limiting may be inherent to the supply or may be provided by supplementary overcurrent devices. If the QTERM-Z60 does not respond or exhibits abnormal behavior on power up, disconnect power and contact Beijer Electronics for technical support.

QTERM-Z60/H / Z60/L Current Consumption		
Terminal	12 VDC	24 VDC
Standard unit, idle	390 mA	200 mA
Standard unit, active	add 40 mA	add 20 mA
Standard unit, 200 mA load on 5 VDC supply	add 140 mA	add 70 mA

6.4.4 Powering On the Terminal for the First Time

When you connect power to the QTERM-Z60 terminal, it automatically loads the application saved in flash memory into RAM memory and executes the application. If no application is present, the terminal display may be blank but the backlighting verifies it is powered on.

When you power on the terminal for the first time, a demo application (or a special application custom designed for your company) loads. The demo application will help you verify that the terminal is operating properly. Follow the on-screen prompts or any documentation accompanying the program to guide you through tests or demonstrations designed to verify terminal operation.

Once you have verified that the terminal is functioning properly, refer to [Chapter 8, “Power On Setup”](#) for information on configuring your terminal. The Power On Setup utility includes functions to do the following:

- Change orientation of the terminal (portrait or landscape)
- Download a new user application to the terminal
- Select the application mode
- Set up communications settings for the terminal
- Adjust display contrast or backlight
- Enter/change password (if used)

Notes

7.1 Product Description

The QTERM-G72 human machine interface terminal is a large display Ethernet-enabled graphic terminal with object-based programming. It features a robust list of industrial grade hardware features and options.

The QTERM-G72 features a vivid WVGA (800 x 480), 177 mm (7"), color graphics TFT-LCD display with 16 bit (65536) color (displayable colors are limited to 256 by Qlarity). The display includes an LED backlight with software controllable dimming. With the included Ethernet 10/100Base-T interface and two serial ports, this terminal is ready to connect to nearly any device.

The analog-resistive touch screen covers the full viewable area of the display. The touch screen is the primary mechanism for user input.

For communications, the QTERM-G72 comes equipped with two serial ports. The primary serial port is software-configurable to EIA-232 (with RTS/CTS flow control), EIA-422, or EIA-485 interfaces. The secondary serial port uses an EIA-232 interface with hardware (RTS/CTS) or software flow control. The terminal also includes one 10/100Base-T Ethernet (RJ45 connector) and one USB 2.0 full speed port (mass storage devices only). The I/O connectors are accessible at the terminal back panel and are angled towards the bottom of the terminal to facilitate mounting in shallow panel areas.

Other key standard features include a speaker, which has programmable pitch and duration, and an audio decoder for playing audio wave files. The terminal also includes a battery-backed real-time clock and a hardware watchdog timer.

The terminal stores the firmware and the user application in a compressed format in flash memory and then transfers them to RAM memory when the terminal is powered on. The terminal is equipped with four megabytes of flash memory and 32 megabytes of RAM memory.

The QTERM-G72 electronics are packaged in a rugged and attractive black thermoplastic NEMA-4X housing that accommodates the same panel cutout as our QTERM-G70 terminal.

The QTERM-G72 terminal requires a DC power source in a range of 10 to 32 VDC. This power can be supplied either via the main DB9 serial connector or the 3-pin power terminal strip (which includes power input, return, and chassis ground).

7.1.1 Specifications

The following tables contain the technical specifications for the QTERM-G72.

TERMINAL DISPLAY	
Type	TFT 16 bit (65536) color limited to 256 by Qlarity
Resolution	WVGA 800 x 480 (approximately 16:9 aspect ratio)
Dot pitch	0.19 mm x 0.19 mm
Lighting	White LED, brightness software-controllable
Backlight brightness	500 nits typical
Contrast ratio	500:1 (minimum)
TOUCH SCREEN	
Analog-resistive operation	
Transparent touch area over viewable display	
INTERFACE	
Primary serial port	User-configurable EIA-232, EIA-422, or EIA-485 interface with selectable 485 AC terminations and fail-safe network
Secondary serial port	EIA-232 serial port with hardware or software flow control
Baud rates	600 – 115,200 bps
Flow control	None Xon/Xoff (software) RTS/CTS (hardware)
Data formats	7 or 8 data bits 1 or 2 stop bits Even, odd, or no parity (PC development tool supports only 8 data bits)
Ethernet	10/100Base-T interface, supports TCP/IP and UDP protocol
USB host	USB 2.0 full speed (12 Mb/sec), supports only mass storage devices
Power connector	3-pin, 5.0 mm pitch terminal block. (Phoenix Contact MSTBVA 2,5/3-G – 1755529)
Connectors	2 DB9f 1 8-pin modular (RJ45) for Ethernet 1 USB type-A 1 3-pin terminal strip
MEMORY	
Standard	4 Mbytes NOR flash 32 Mbytes SDRAM

SPEAKER	
Standard	Software programmable pitch and duration with audio (.wav) decoder
REAL-TIME CLOCK	
Independent processor-based, real-time clock with battery backup, 1 second resolution	
PHYSICAL	
Configuration	Panel-mount
Size	224 (W) x 154 (H) x 60 (D) mm
Weight	1 kg
Processor	ARM926EJ-S 192 MHz
ENVIRONMENTAL	
Sealing	NEMA-4X front panel
Temperature	Operating: -20 to 70 °C Storage: -30 to 85 °C
Humidity	5 to 95%, non-condensing
Vibration	10 to 1500 Hz, 4 g, 0.5 octave/minute sweep 5 to 500 Hz, 1.5 g RMS
Shock	40 g, 11 ms, common orthogonal axis
ESD	8 kV contact 15 kV air
POWER	
10 to 32 VDC (See section 7.4.3 for current consumption)	
SOFTWARE	
Programming language	Qlarity (object-based)
Design environment	Qlarity Foundry (Windows)
Command line compiler	Qlarify (Win32 or Linux)
CERTIFICATION	
FCC Part 15, Class A CE Certification EN-55022, EN-55024 and EN-60950 UL Listed	

7.2 Supported Interfaces

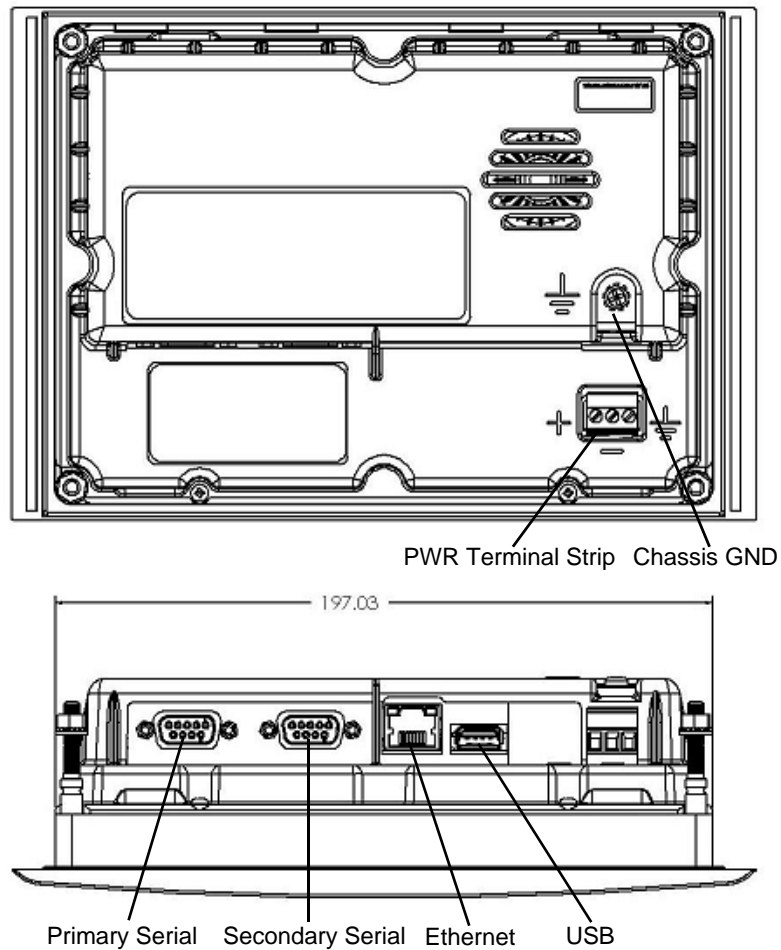



Figure 32
QTERM-G72 Supported Interfaces

7.2.1 Primary Serial Port (Multiprotocol Port Interface)

The primary serial port is user configurable to EIA-232, EIA-422, or EIA-485 interface.

NOTE  The primary and secondary serial ports are wired as Data Communications Equipment (DCE).

EIA-232	with proper cables and grounding the terminal can communicate up to five meters at a top speed of 115,200 bps
EIA-422	permits operation at distances up to 2,000 meters
EIA-485	permits multiple terminals to be connected in a multi-drop chain

Figure 33 shows the serial connector's orientation.

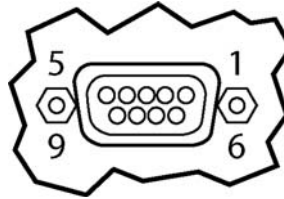

Figure 33
QTERM-G72 Serial Connector

The table below shows the pinouts for each type of serial interface on the primary serial port.

Pin	EIA-232	EIA-422	EIA-485
1	—	—	—
2	TX	TX-	RTX-
3	RX	RX+	—
4	—	—	—
5	Ground	Ground	Ground
6	—	—	—
7	CTS (in)	RX-	—
8	RTS (out)	TX+	RTX+
9	Power In	Power In	Power In

Power can be supplied to the terminal through pin 9 and ground return through pin 5 of the primary serial port connector.

CAUTION



Although the terminal includes protection circuitry to prevent power supply contention, power should not be simultaneously connected to both the 3-pin terminal strip and the primary DB9 connectors.

7.2.2 Secondary Serial Port

The secondary serial port on the QTERM-G72 is configured as EIA-232 only with hardware or software handshaking. The pins are defined below.

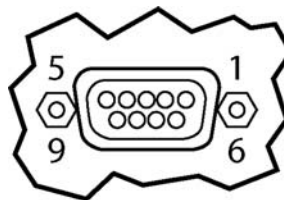

Figure 34
QTERM-G72 Serial Connector

Pinout Table	
1	—
2	TX
3	RX
4	—
5	Ground
6	—
7	CTS (in)
8	RTS (out)
9	—

7.2.3 Ethernet Port

The Ethernet port has a standard 10/100Base-T interface with an 8-pin (RJ-45) modular jack connector and uses TCP/IP protocol. The connector orientation and pinout table are shown below.

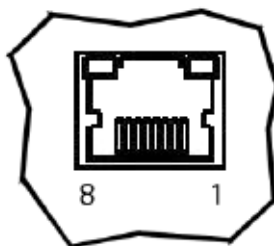

Figure 35
QTERM-G72 Ethernet Port

Pinout Table	
1	TX+
2	TX-
3	RX+
4	—
5	—
6	RX-
7	—
8	—

7.2.4 USB 2.0 Port

The QTERM-G72 includes a device USB 2.0 full-speed port. Only mass storage devices are compatible with the QTERM-G72.

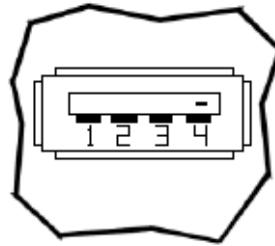

Figure 36
QTERM-G72 USB Port

7.2.5 Terminal Strip for Power Input

The 3-pin terminal strip is used to provide input voltage and ground to the terminal. The terminal strip provides a chassis ground connection. The chassis ground pin is isolated from the system ground of the terminal.

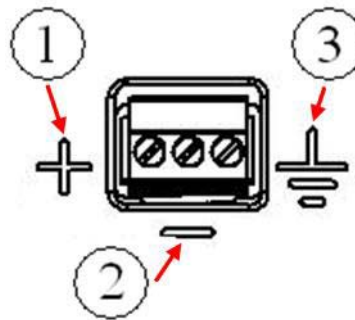

Figure 37
QTERM-G72 3-Pin Terminal Strip

Pin	Function
1	Power
2	Ground
3	Chassis GND

7.3 Terminal Components

7.3.1 Touch Screen

The QTERM-G72 touch screen allows user input in your applications at any location within the viewable area of the display.

7.3.2 Speaker

A speaker is built into the QTERM-G72 terminal and faces to the back of the unit. Audio can be linked to events or actions (e.g., screen press, timer, etc.). Pitch and duration of a sound are controlled by API functions called from the user application. Refer to the “Controlling the Speaker” section in the *Qlarity-based Terminal Programmer's Reference Manual*.

Also, an audio (.wav) decoder is available to allow the speaker to play audio files. The audio decoder supports wave files meeting the following criteria:

- Sample rate of 8 kHz, 11.025 kHz, 16 kHz or 22.050 kHz
- Resolution of 8 or 16 bits per sample.

The audio decoder circuit amplifies the signal to 0.5 W rms at the speaker.

7.3.3 Real-Time Clock

The QTERM-G72 terminal is equipped with a battery-backed, real-time clock. The real-time clock can be used to time/date stamp messages or for timed polling and program execution.

WARNING



There may be danger of leakage if the battery is incorrectly replaced, creating a potential health hazard. Replace the battery only with the same (CR 2032) or equivalent type as recommended by the manufacturer. Dispose of used batteries according to the battery manufacturer's instructions.

7.3.4 System Memory

The QTERM-G72 terminal stores the firmware and user applications in a compressed format in flash memory and then transfers them to RAM memory when the terminal is powered on. Four megabytes of flash memory and 32 megabytes of RAM memory are included on the standard unit.

For information on using resources efficiently to conserve memory when creating a user application, refer to “Edit Resources” section in the *Qlarity Foundry Manual*.

For information on downloading new firmware, downloading a user application, and determining the size of a user application, refer to the *Qlarity Foundry Manual*.

7.3.5 Watchdog Timer

A watchdog timer is included to enforce proper operation of the QTERM-G72. The watchdog timer will reset the terminal if there is a problem causing the firmware to lock up. This does not apply to software deadlocks in the Qlarity code. If that is required, then the Qlarity watchdog timer should be used, using the WatchdogEnable and WatchdogReset APIs.

7.4 Installing to NEMA-4X Specifications

A QTERM-G72 terminal uses a rugged chemical resistant polymer for the housing and mounting components. When properly installed in a NEMA-4X rated panel, the QTERM-G72 meets all NEMA-4X specifications including hose-down, icing, and salt spray. The QTERM-G72 accommodates the same panel cutout as the QTERM-G70 terminal.

A QTERM-G72 terminal can be installed with either landscape or portrait orientation. When installing a terminal, you generally take the following steps:

- Decide whether you want to mount and use the terminal in portrait or landscape orientation. “Portrait” means that the longest dimension is vertical; “landscape” means that the longest dimension is horizontal. (A cutout template is included with the terminal.)
- Cut a hole in the panel or drywall. See [section 7.4.1, “Cutting Out for Panel Mount”](#) for specifications.
- Install the QTERM-G72 terminal in the panel. See [section 7.4.2, “Installing the Terminal”](#) for instructions.
- Connect cables to the terminal. Verify that the thumb screws are tight or the locks snapped into place for each cable used.
- Apply DC power to the QTERM-G72 terminal. See [section 7.4.3, “Applying Power”](#) for information.

7.4.1 Cutting Out for Panel Mount

The QTERM-G72 terminal can be mounted in panels from 0.8 to 12 mm thick. No screw holes need to be drilled to install the terminal in the panel. Make a rectangular hole in the panel using the following dimensions.

Landscape	Portrait
Horizontal: 199 ± 1 mm	Horizontal: 145 ± 1 mm
Vertical: 145 ± 1 mm	Vertical: 199 ± 1 mm

Figure 38 is a diagram of the landscape cutout.

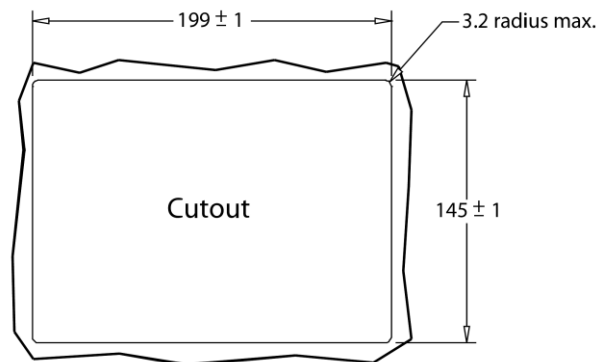



Figure 38
QTERM-G72 Landscape Cutout

File any rough edges smooth, especially on the face of the panel.

7.4.2 Installing the Terminal

Take the following steps to install the terminal.

NOTE  *Use of an anti-static strap is recommended when performing installation and maintenance.*

1. Verify that the panel surface around the cutout is clean and free of rough edges. A gasket built into the terminal seals against the panel surface. Dirt or imperfections on the panel may prevent a proper seal.
2. Place the terminal into the panel cutout and verify that the terminal is oriented correctly. The Beijer Electronics logo on the front panel, if included, or the printed labels on the back panel may indicate the orientation. If not, you can determine which side should be at the top by the position of the serial port(s) on the back panel as follows:
 - Landscape
When looking at the front of the unit, the back panel serial port(s) should be facing down.
 - Portrait
When looking at the front of the unit, the back panel serial port(s) should be facing left. Refer to Figure 39 for an example of a portrait installation.

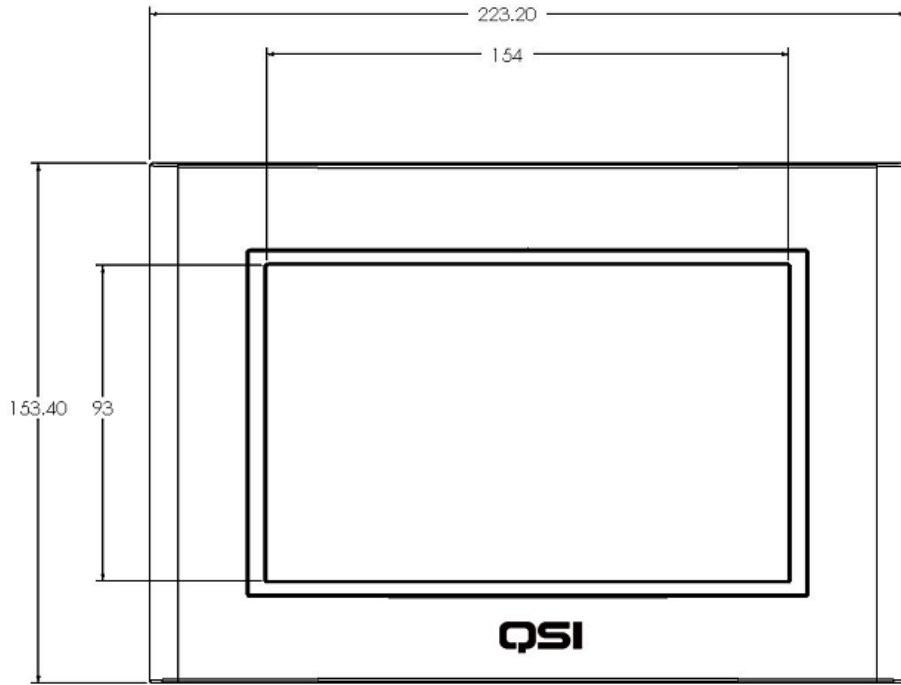

Figure 39
QTERM-G72 Front Panel Mount

3. On the back of the panel, align the terminal mounting ring holes with the mounting studs, and place the mounting ring against the back of the panel. Refer to Figure 40 for the loca-

tion of the mounting studs.

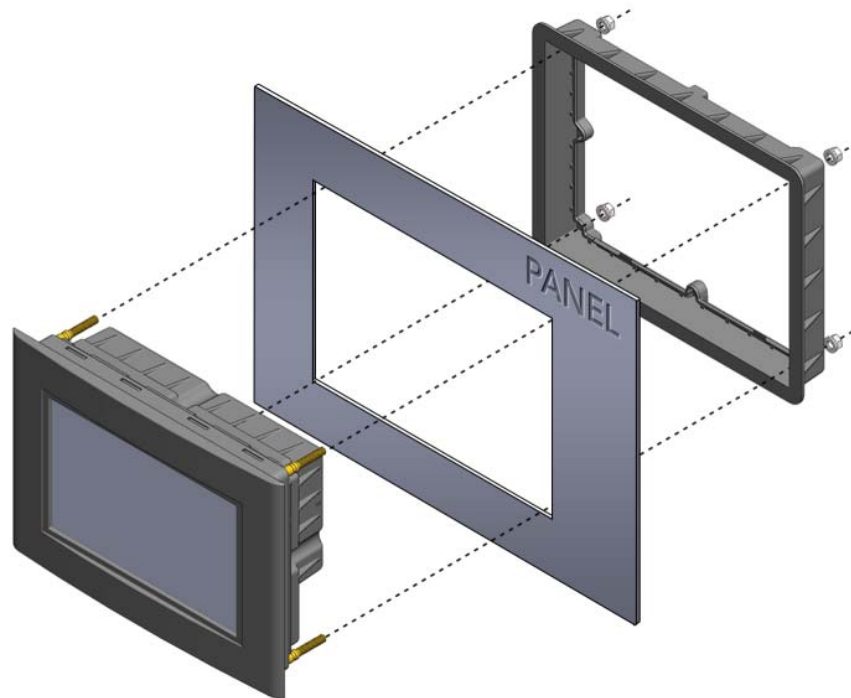

Figure 40
QTERM-G72 Panel Mounting

4. Install nuts and washers (supplied with the terminal) onto each of the four mounting studs. Tighten all nuts to create the seal between the terminal gasket and the panel. Avoid over-tightening the nuts.

7.4.3 Applying Power

Power is supplied to the QTERM-G72 terminal via the primary serial port connector or the 3-pin power terminal strip for input power, return, and chassis ground. Refer to [section 7.2.1, “Primary Serial Port \(Multiprotocol Port Interface\)”](#) for the pin assignments for power and ground. DC power must be in the range of 10 to 32 volts (the current will vary depending on the input voltage; see table below).

Make sure to connect the chassis ground connection first.

CAUTION



Although the terminal includes protection circuitry to prevent power supply contention, power should not be simultaneously connected to both the 3-pin terminal strip and the primary DB9 connectors.

CAUTION

QTERM-G72 power must come from an SELV (Safety Extra Low Voltage) power source and should have a current limit on its output of 5 Amperes. It must provide a minimum of 10 volts DC power and be limited to a maximum of 32 volts DC. Limiting may be inherent to the supply or may be provided by supplementary overcurrent devices. If the QTERM-G72 does not respond or exhibits abnormal behavior on power up, disconnect power and contact Beijer Electronics for technical support.

Typical Current Consumption		
Terminal	12 VDC	24 VDC
Standard TFT unit (idle)	460 mA	280 mA
Standard TFT unit (active)	530 mA	320 mA

7.4.4 Powering On the Terminal for the First Time

Make sure to connect the chassis ground connection first.

When you connect power to the QTERM-G72 terminal, it automatically loads the application saved in flash memory into RAM memory and executes the application. If no application is present, the terminal display is blank but the back-lighting verifies that it is powered on.

When you power on the terminal for the first time, a demo application (or a special application custom designed for your company) loads. The demo application will help you verify that the terminal is operating properly. Follow the on-screen prompts or any documentation accompanying the program to guide you through tests or demonstrations designed to verify terminal operation.

Once you have verified that the terminal is functioning properly, refer to [Chapter 8, “Power On Setup”](#) for information on configuring your terminal. The Power On Setup utility includes functions to do the following:

- Change orientation of the terminal (portrait or landscape)
- Download a new user application to the terminal
- Select the application mode
- Set up communications settings for the terminal
- Adjust display contrast or backlight
- Enter network (Ethernet) settings
- Enter/change password (if used)
- Set the real-time clock

Notes

CHAPTER 8

POWER ON SETUP

The Power On Setup utility is used to set up or change the operation settings of the terminal. Power On Setup includes functions to do the following:

- Download new firmware to the terminal
- Download user applications to the terminal
- Select the application mode
- Set communications settings for the terminal
- Adjust display settings (contrast, backlight, orientation)
- Enter network (Ethernet) settings
- Enter/change password (if used)
- Perform touch screen calibration (touch screen-based terminals only)
- Set the real-time clock

Most of these parameters can also be accessed and changed by the application at runtime. Refer to the Qlarity Foundry online documentation for the `GetSystemSetting()` and `SetSystemSetting()` API functions.

The method of entering the Power On Setup utility varies depending on whether you use a touch screen, a keypad or a keyboard. Instructions are provided for each type of input device in the following sections.

8.1 Using a Touch Screen

The touch areas used to enter the Power On Setup utility and calibrate the touch screen are not shown on the screen. However, after you enter the Power On Setup utility, the touch keys used to perform the functions are shown on the screen, with the exception of the QTERM-G58 (see the note on [page 99](#)).

The **[Setup]** touch area on a screen in landscape orientation is the left quarter of the touch screen, and the **[Calibration]** touch area is the right quarter of the touch screen. If the terminal screen is in portrait orientation, the **[Setup]** touch area is the top quarter of the touch screen, and the **[Calibration]** touch area is the bottom quarter of the touch screen. This means that you can touch the upper left corner to access the Power On Setup utility and the lower right corner to perform calibration in either orientation.

Figure 41 and Figure 42 identify the touch areas in each orientation.

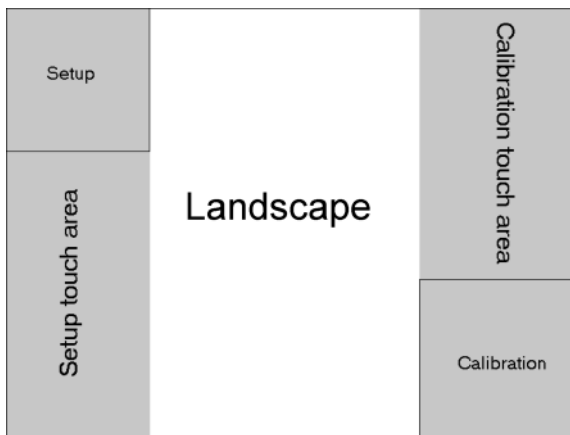

*Figure 41
Touch Screen Landscape Orientation*

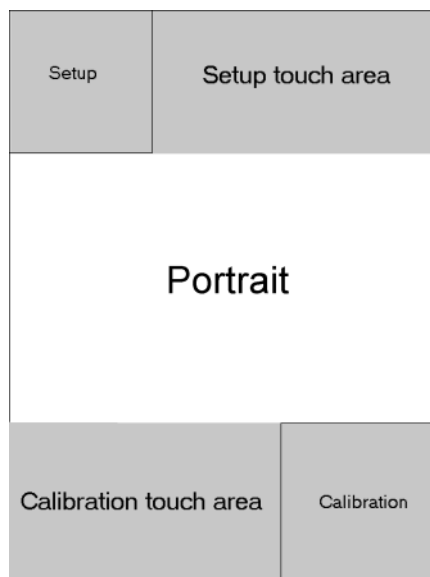

*Figure 42
Touch Screen Portrait Orientation*

NOTE  *If your touch screen is not working properly, it may need calibration. Refer to [section 8.5](#) for instructions.*

Do the following to start Power On Setup using a touch screen.

1. Turn off power to the terminal.
2. Press and hold the **[Setup]** touch area (see Figures 41 and 42) as you power on the terminal.

3. Continue pressing until “Power On Setup” appears on the screen, then release the touch area.
4. If a password is required, the prompt, “Enter password,” is displayed. Press the arrow touch keys on the screen (↑ ↓ ← →) to enter the password, and then press **[Select]**. After the password is entered, Power On Setup starts.

If you enter the password incorrectly, you must power the terminal off and back on and start over if you want to access all Power On Setup functions.

If a password is required but not entered or entered incorrectly, Power On Setup starts and some limited functions are available including Display, Calibration, and Done.

Use the touch keys described below to select functions and options in Power On Setup.

To move from category to category:

Press **[Next]** to move forward from one category of functions (e.g., Flash Memory, Display, Calibration, etc.) to another. A heading is highlighted when you move to it. Continue to press **[Next]** to move to the next page. Press **[Back]** to move backwards through the categories.

To move within a category:

When the heading of the category you want to edit is highlighted, press **[Select]** to move to the first function. Press **[Next]** and **[Back]** to move from function to function in the category. To go back to the category heading, go to the topmost function in the category and press **[Back]**; or go to the bottommost function and press **[Next]**. **[Next]** and **[Back]** then move from category to category again.

To change a function:

When at a function that you want to edit, press **[Select]** to move to the available options. Press **[Next]** or **[Back]** to toggle through the options (e.g., “off” and “on”). When the option you want is displayed, press **[Select]** to select the option and move back to the function name.

To save and exit:

When you are ready to exit Power On Setup, press either **[Next]** or **[Back]** (with a category heading highlighted) to move to **DONE** on the last page, and press **[Select]**. “Save and Exit” is highlighted. Press **[Select]** to save your changes and exit Power On Setup. To exit without saving the changes, press **[Next]** to move to **Exit w/o Save** and then press **[Select]**.

NOTE  Due to screen size limitations, the QTERM-G58 Power On Setup screen does not include touch keys for **[Next]**, **[Back]** and **[Select]**. Instead, use the keypad as described in [section 8.2](#).

Refer to [section 8.4](#) for information on specific functions.

8.2 Using a Keypad

You will use the left-most three keys on the top row of the keypad to navigate in Power On Setup. On the Beijer Electronics standard legends, these keys are labeled F1, F2 and F3. Key assignments are as follows.

F1	[Back]	move between categories, functions and options
F2	[Select]	select a category, function or option
F3	[Next]	move between categories, functions and options

Do the following to start Power On Setup using a keypad.

1. Turn off power to the terminal. You will need to remove power from the terminal or unplug it to turn off the power.
2. Press and hold any three keys (other than the Power key) as you power on the terminal. If the terminal is in Development Mode (see below), press and hold any single key (other than the Power key) as you apply power to the terminal
3. Continue to hold these keys until the words “Power On Setup” appear on the screen, then release the keys.
4. If a password is required, the prompt, “Enter password,” is displayed. Press the password key sequence on the keypad to enter the password, then press the **[Select]** key. After the password is entered, Power On Setup starts.

If you enter the password incorrectly, you must power the terminal off and back on and start over if you want to access all Power On Setup functions.

If a password is required but not entered or entered incorrectly, Power On Setup starts and some limited functions are available including Display, Calibration, and Done.

Use the keypad keys described below to select functions and options in Power On Setup.

To move from category to category:

Press **[F3]** to move forward from one category of functions (e.g., Flash Memory, Display, Calibration, etc.) to another. A heading is highlighted when you move to it. Continue to press **[F3]** to move to the next page. Press **[F1]** to move backwards through the categories.

To move within a category:

When the category heading you want to edit is highlighted, press **[F2]** to move to the first function. Press **[F1]** and **[F3]** to move from function to function in the category. To go back to the category heading, go to the topmost function and press **[F1]**; or go to the bottommost function and press **[F3]**. **[F1]** and **[F3]** then move from category to category again.

To change a function:

When at a function that you want to edit, press **[F2]** to move to the available options. Press **[F1]** and **[F3]** to toggle through the options (e.g., “off” and “on”). When the option you want is displayed, press **[F2]** to select the option and move back to the function name.

Saving and Exiting:

When you are ready to exit Power On Setup, press either **[F1]** or **[F3]** (with a category heading highlighted) to move to **DONE** on the last page, and press **[F2]**. “Save and Exit” is highlighted. Press **[F2]** to save your changes and exit Power On Setup. To exit without saving the changes, press **[F3]** to move to **Exit w/o Save** and press **[F2]**.

Refer to [section 8.4](#) for information on specific functions.

8.3 Using a Keyboard

You will use the following keyboard keys in Power On Setup.

- <P> start Power On Setup
- ← → move between categories, functions, and options
- <Enter> select a category, function, or option

Do the following to start Power On Setup using a keyboard.

1. Turn off power to the terminal.
2. Press and hold the <P> key as you power on the terminal.
3. Continue to hold <P> until the words “Power On Setup” appear on the screen, then release the key.
4. If a password is required, the prompt, “Enter password,” is displayed. Press the arrow keys (↑ ↓ ← →) on the keyboard (not the number key pad) to enter the password, and then press <Enter>. After the password is entered, Power On Setup starts.

If you enter the password incorrectly, you must power the terminal off and back on and start over if you want to access all Power On Setup functions.

If a password is required but not entered or entered incorrectly, Power On Setup starts and some limited functions are available including Display, Calibration, and Done.

Use the keyboard keys described below to select functions and options in Power On Setup.

To move from category to category:

Press → to move forward from one category of functions (e.g., Flash Memory, Display, Calibration, etc.) to another. A heading is highlighted when you move to it. Continue to press → to move to the next page. Press ← to move backwards through the categories.

To move within a category:

When the category heading you want to edit is highlighted, press **<Enter>** to move to the first function. Press **→** and **←** to move from function to function in the category. To go back to the category heading, go to the topmost function and press **←**; or go to the bottommost function and press **→**. **→** and **←** then move from category to category again.

To change a function:

When at a function that you want to edit, press **<Enter>** to move to the available options. Press **→** and **←** to toggle through the options (e.g., “off” and “on”). When the option you want is displayed, press **<Enter>** to select the option and move back to the function name.

Saving and Exiting:

When you are ready to exit Power On Setup, press either **→** or **←** (with a category heading highlighted) to move to **DONE** on the last page, and press **<Enter>**. “Save and Exit” is highlighted. Press **<Enter>** to save your changes and exit Power On Setup. To exit without saving the changes, press **→** to move to **Exit w/o Save** and then press **[Enter]**.

Refer to [section 8.4](#) for information on specific functions.

8.4 Power On Setup Functions

This section describes the functions in the Power On Setup utility by category. The categories are as follows:

- Flash Memory
- Display
- Calibration
- Network (with optional Ethernet port only)
- COM1 (and any additional installed serial ports)
- Keypad (optional)
- Keyboard (optional)
- Sound
- Feedback
- Miscellaneous
- Diagnostics (with keyboard/keypad only)
- Done

The following descriptions provide instructions for using the touch keys on a touch screen. If you are using a keyboard, the corresponding keyboard keys are as follows.

Touch key	Keyboard key	Keypad key
[Select]	<Enter>	[F2]
[Back]	←	[F1]
[Next]	→	[F3]

8.4.1 Flash Memory

The Flash Memory functions are used to place the terminal in the proper mode to download new firmware or a user application, place the terminal in the proper mode for developing a new user application or normal operation, and erase the flash file system.

8.4.1.1 App Mode

Download:

Select this option to place a terminal with either a serial port or the optional Ethernet port in the mode to download new firmware or a new user application that you want saved in flash memory. (Use “App Mode: Develop” if you do not want to save the user application to flash memory.) The terminal waits for the download and detects the type of file (firmware or user application) as it is sent.

NOTE  *If using an Ethernet port, make sure you have selected the proper network settings (see [section 8.4.4](#)).*

Press **[Next]** or **[Back]** to move to **FLASH MEMORY**. Press **[Select]** to move to **App Mode**, and press **[Select]** again to move to the options. Press **[Next]** or **[Back]** to select **Download**, then press **[Select]** to return to the function name.

Press **[Next]** or **[Back]** to move to the **DONE** section, and select **Save and Exit**. The terminal is ready to receive a download.

Download the firmware or a user application using the “Download Application” or “Upgrade Firmware” function in Qlarity Foundry (refer to the *Qlarity Foundry User's Manual* for instructions). When the unit is reset, it will automatically go into the Run App mode.

Press **[Next]** or **[Back]** to move to the **DONE** section, and select **Save and Exit** to exit Power On Setup.

Develop:

Select this option to set the terminal to the “Develop” application mode, normally only used when you are developing a new user application and want to download it to the terminal without saving it in flash memory. Press **[Next]** or **[Back]** to move to **FLASH MEMORY**. Press **[Select]** and then **[Next]** to move to **App Mode**, and press **[Select]** again to move to the

options. Press **[Next]** or **[Back]** to select **Develop**, then press **[Select]** to return to the function name.

Press **[Next]** or **[Back]** to move to the **DONE** section, and select **Save and Exit**. The terminal is ready for the user application to be downloaded.

Download the application through the serial or Ethernet port interface using the “Download Application” function in Qlarity Foundry (refer to the *Qlarity Foundry User's Manual* for instructions). (If you use an Ethernet port, make sure you have selected the proper network settings; see [section 8.4.4](#).)

While the terminal is in “Develop” mode, a user application downloaded to the terminal is not saved in flash memory. This saves unnecessary wear on the flash memory and speeds up download time while testing an application in development. However, the application is removed when the terminal is powered off.

If you previously downloaded an application using the “App Mode: Download” function, that application remains in flash memory (it is not overwritten by an application downloaded while in develop mode). This makes it possible to test a new application without copying over an existing application.

Press **[Next]** or **[Back]** to move to the **DONE** section, and select **Save and Exit** to exit Power On Setup.

Run App:

Select this option to set the terminal to the “Run App” operational mode. If the terminal is in “Run App” mode and a user application was saved in flash memory, the application runs when the terminal is powered on.

Press **[Next]** or **[Back]** to move to **FLASH MEMORY**. Press **[Select]** and then **[Next]** to move to **App Mode**, and press **[Select]** again to move to the options. Press **[Next]** or **[Back]** to select **Run App**, then press **[Select]** to return to the function name.

Press **[Next]** or **[Back]** to move to the **DONE** section, and select **Save and Exit** to exit Power On Setup.

Run Default:

Select this option to set the terminal to the “Run Default” operational mode. If the terminal is in “Run Default” mode, the default application associated with the firmware runs when the terminal is powered on. Not all firmware builds have a default application. Press **[Next]** or **[Back]** to move to **FLASH MEMORY**. Press **[Select]** and then **[Next]** to move to **App Mode**, and press **[Select]** again to move to the options. Press **[Next]** or **[Back]** to select **Run Default**, then press **[Select]** to return to the function name.

Press **[Next]** or **[Back]** to move to the **DONE** section, and select **Save and Exit** to exit Power On Setup.

8.4.1.2 Erase FFS

Use this function to erase the flash file system. The flash file system is used to store data collected by the application. The data is saved to flash memory so that it is available even after the terminal has been powered off and back on.

Press **[Next]** or **[Back]** to move to **FLASH MEMORY**. Press **[Select]** and then **[Next]** to move to **Erase FFS**, and press **[Select]** again to move to the options. Press **[Next]** or **[Back]** to select **Yes**. **The flash file system is erased when you press [Select] to return to the function name.**

If you do not want to erase the flash file system, select **No**, and press **[Select]** to return to the function name.

Press **[Next]** or **[Back]** to move to the **DONE** section, and select **Save and Exit** to exit Power On Setup.

8.4.2 Display

The Display functions are used to adjust the terminal display's contrast setting, adjust the brightness of the display's backlighting, change the orientation of the display (portrait or landscape), and use of draw caching.

8.4.2.1 Contrast

Use this function to adjust the contrast setting of the terminal display. It will not appear on TFT units.

Press **[Next]** or **[Back]** to move to **DISPLAY**. Press **[Select]** to move to **Contrast**, and press **[Select]** again to move to the options. The label, "(adjust)" is displayed on the right. Press **[Next]** or **[Back]** until the contrast is at the desired level. Press **[Select]** to return to the function name.

Press **[Next]** or **[Back]** to move to the **DONE** section, and select **Save and Exit** to exit Power On Setup.

NOTE  *The contrast can also be adjusted using an API function (see the Qlarity-based Terminal Programmer's Reference Manual.).*

8.4.2.2 Backlight

Use this function to adjust the brightness of the display.

Press **[Next]** or **[Back]** to move to **DISPLAY**. Press **[Select]** and then **[Next]** to move to **Backlight**, and press **[Select]** again. The label, "(adjust)" is displayed on the right. Press **[Next]** or **[Back]** until the backlight is at the desired level. Press **[Select]** to return to the function name.

Press **[Next]** or **[Back]** to move to the **DONE** section, and select **Save and Exit** to exit Power On Setup.

8.4.2.3 Orient

Use this function to change the orientation of the terminal display to match the physical terminal orientation. If the terminal is turned so that the longest dimension is vertical, select “portrait”; if the longest dimension is horizontal, select “landscape.”

Press **[Next]** or **[Back]** to move to **DISPLAY**. Press **[Select]** and **[Next]** to move to **Orient**, and press **[Select]** again to move to the options. Press **[Next]** or **[Back]** to select **Portrait** or **Landscape**. Press **[Select]** to return to the function name.

Press **[Next]** or **[Back]** to move to the **DONE** section, and select **Save and Exit** to exit Power On Setup.

8.4.2.4 Touch

Use this function to enable or disable the touch screen functionality on terminals with touch screens (this item will not appear in Power On Setup if the terminal does not have a touch screen).

Press **[Next]** or **[Back]** to move to **DISPLAY**. Press **[Select]** and **[Next]** to move to **Touch**, and press **[Select]** again to move to the options. Press **[Next]** or **[Back]** to select **On** or **Off**, then press **[Select]** to return to the function name.

Press **[Next]** or **[Back]** to move to the **DONE** section, and select **Save and Exit** to exit Power On Setup.

8.4.2.5 DCache

In applications where many objects are layered on top of each other, you may see a small latency when the screen updates. Draw caching stores objects in memory to improve display performance but does require more RAM to function.

There are currently four different levels of drawcaching supported (listed in order of amount of memory used).

Off	no objects are cached
Effective Enabled	only objects that are enabled and whose parents are enabled back to root are cached
Enabled	all enabled objects are cached
All	all objects are cached

Press **[Next]** or **[Back]** to move to **DISPLAY**. Press **[Select]** and **[Next]** to move to **DCache**, and press **[Select]** again to move to the options. Using **[Next]** and **[Back]**, select the level of draw caching desired. Press **[Select]** to return to the function name.

8.4.3 Calibration

The Calibration functions are used to calibrate the terminal to the air temperature and to calibrate the touch screen if it is not working properly.

8.4.3.1 Temp

A default temperature is set at the factory. If there is more than a 5 °Celsius difference between the default temperature shown and the surrounding air temperature, you may want to change this setting. This parameter is used in the terminal to help with display contrast compensation.

Press **[Next]** or **[Back]** to move to **CALIBRATION**. Press **[Select]** to move to **Temp**, and press **[Select]** again. Press **[Next]** or **[Back]** until the correct temperature is displayed, then press **[Select]** to return to the function name.

NOTE 

*The temperature sensor in the QTERM-G55 does not require calibration. Therefore, the current temperature is shown, but it cannot be modified with the **[Next]** or **[Back]** key.*

Press **[Next]** or **[Back]** to move to the **DONE** section, and select **Save and Exit** to exit Power On Setup.

8.4.3.2 Date

This function is used to set or change the real-time clock's date (if the real-time clock is available).

Press **[Next]** or **[Back]** to move to **CALIBRATION**, and press **[Select]** to move to **Date**. Then change the day, date, month, and year, as follows.

Press **[Select]** again to move to the “day of the week” field, and press **[Next]** or **[Back]** to change the day.

The date is entered in a two-digit field (01, 02, 10, etc.). Press **[Select]** to move to the first digit in the “date” field, and press **[Next]** or **[Back]** to change the digit. Press **[Select]** to move to the second digit in the “date” field, and press **[Next]** or **[Back]** to change the digit.

Press **[Select]** to move to the “month” field, and press **[Next]** or **[Back]** to change the month.

The year is entered in a two-digit field. Press **[Select]** to move to the first digit in the “year” field, and press **[Next]** or **[Back]** to change the digit. Press **[Select]** to move to the second digit in the “year” field, and press **[Next]** or **[Back]** to change the digit.

Press **[Select]** at the last digit to return to the function name. The date is immediately changed.

NOTE  *If you are using a keyboard, you can use the number keys (0–9) to enter the digits. If you are using a terminal with a keypad (24- or 40-key with standard Beijer Electronics legend), you can use the number keys (0-9) to enter the digits.*

Press **[Next]** or **[Back]** to move to the **DONE** section, and select **Save and Exit** to exit Power On Setup.

8.4.3.3 Time

This function is used to set or change the real-time clock's time. Press **[Next]** or **[Back]** to move to **CALIBRATION**, and press **[Select]** to move to **Time**. Then enter the hour, minutes, and seconds in 24-hour (or military) time (e.g., 13:10:25 for 1:10:25 p.m.) as follows.

Press **[Select]** to move to the first digit in the “hour” field, and press **[Next]** or **[Back]** to change the digit. Press **[Select]** to move to the second digit in the “hour” field, and press **[Next]** or **[Back]** to change the digit.

Press **[Select]** to move to each digit in the “minutes” field, and press **[Next]** or **[Back]** to change the digits.

Press **[Select]** to move to each digit in the “seconds” field, and press **[Next]** or **[Back]** to change the digits.

Press **[Select]** at the last digit to return to the function name. The time is immediately changed.

NOTE  *If you are using a keyboard, you can use the number keys (0–9) to enter the digits. If you are using a terminal with a keypad (24 or 40 key with standard Beijer Electronics legend), you can use the number keys (0-9) to enter the digits.*

Press **[Next]** or **[Back]** to move to the **DONE** section, and select **Save and Exit** to exit Power On Setup.

8.4.3.4 Touchscreen

You will only see this function if you are using a touch screen-based terminal. If the touch screen is not working properly, you can use this function to calibrate it.

NOTE  *You can also calibrate the touch screen without entering the Power On Setup utility (see [section 8.5](#)).*

Press **[Next]** or **[Back]** to move to **CALIBRATION**. Press **[Select]** and **[Next]** to move to **Touchscreen**, and press **[Select]** again. The message, “TOUCHSCREEN CALIBRATION, Please press center of cross” is displayed, and a “+” symbol appears on the screen.

Press the “+” symbol. The symbol moves to the bottom of the display. Press the “+” symbol in its new location. This completes calibration. When finished, the terminal returns to Power On Setup.

Press **[Next]** or **[Back]** to move to the **DONE** section, and select **Save and Exit** to exit Power On Setup.

8.4.4 Network

This function is only seen if your terminal has the optional Ethernet communications port. Use this function to enter network addresses for the Ethernet port. If you do not know the network addresses, consult your network administrator.

Press **[Next]** and **[Back]** to move to **NETWORK**. Press **[Select]** and **[Next]** to move to **DHCP** or the desired address field. For DHCP, press **[Select]** to move to the options, then press **[Next]** or **[Back]** to select **On** or **Off**. Press **[Select]** to return to the function name. For the address fields, press **[Select]** at the desired field to move to the first digit of the address. Press **[Next]** or **[Back]** to change the digit’s value. Press **[Select]** to move to the next digit and press **[Next]** or **[Back]** to change it. Continue to press **[Select]** and change each digit in the address as required. Press **[Select]** at the last digit to return to the function name.

NOTE  *If you are using a keyboard, you can use the number keys (0–9) to enter the digits. If you are using a terminal with a keypad (24 or 40 key with standard Beijer Electronics legend), you can use the number keys (0-9) to enter the digits.*

DHCP: On | Off

Enable or disable Dynamic Host Configuration Protocol. DHCP allows the unit to obtain its network configuration (IP address, subnet mask, gateway) dynamically from a server on the local area network. When DHCP is turned on, the address fields will disappear. They will re-appear when DHCP is turned off. **There may be a short delay while the unit updates the network settings when DHCP is turned on.**

IP: xxx.xxx.xxx.xxx

Enter the terminal’s IP address.

Sub: xxx.xxx.xxx.xxx

Enter the subnet mask.

Gate: xxx.xxx.xxx.xxx

Enter the IP address of the gateway (default route).

Press **[Next]** or **[Back]** to move to the **DONE** section, and select **Save and Exit** to exit Power On Setup.

8.4.5 Wireless

This function is only seen if your terminal has the optional 802.11b/g wireless Ethernet interface. Use this function to enter the service set and connection type information for the wireless network which your terminal will connect to. If you do not know this information, consult your network administrator.

Press **[Next]** and **[Back]** to move to **WIRELESS**. Press **[Select]** to enter the submenu, then press **[Next]** to move to the desired field.

SSID: <string, 24 characters or less>

Press **[Select]** with “SSID” highlighted to begin entering the new 802.11 Service Set Identifier. Press **[Next]** and **[Back]** to cycle through the alphanumeric characters. Press **[Select]** to select the highlighted character and move to the next character. To terminate entry after all desired characters in the string are entered, press **[Next]** until the termination symbol <> is displayed, then press **[Select]**. **The Power On Setup SSID entry method supports alphanumeric characters only. If the SSID must contain other characters, the SSID must be set by the application (see the online documentation for the SetSystemSettings() API function).**

Net Type: Infra | Ad Hoc

This item is used to select Infrastructure or Ad Hoc mode for wireless communications. Press **[Select]** with “Net Type” highlighted, then press **[Next]** or **[Back]** to select the desired mode. Press **[Select]** to complete selection.

Chan:

This item is used to select the 802.11 channel for wireless communications. This value is only important if the interface is to be used in Ad Hoc mode. Press **[Select]** with “Chan” highlighted to begin channel selection. Press **[Next]** or **[Back]** to cycle through the available channels until the desired setting is displayed. Then press **[Select]** to complete selection.

Region:

This item is used to select the geographical region where the 802.11 wireless interface will be used, as the channel frequencies vary by region. Due to current agency certification limitations, only the North American region is supported at this time.

8.4.6 Security

This function is only seen if your terminal has the optional 802.11b/g wireless Ethernet interface. Use this function to enter the wireless security settings and keys for the wireless network which your terminal will connect to. If you do not know this information, consult your network administrator.

Press **[Next]** and **[Back]** to move to **SECURITY**. Press **[Select]** to enter the submenu, then press **[Next]** to move to the desired field.

Auth: Open | SharedKey | WPA PSK | WPA None | WPA2 PSK

This item selects the 802.11 authentication scheme. Press **[Select]** with “Auth” highlighted to begin selection. Press **[Next]** and **[Back]** until the desired scheme is displayed. Press **[Select]** to complete selection.

Encryp: None | WEP128 | TKIP | AES

This item selects the 802.11 encryption algorithm. Press **[Select]** with “Encryp” highlighted to begin selection. Press **[Next]** and **[Back]** until the desired algorithm is displayed. Press **[Select]** to complete selection.

WEP Key: 1-4

If WEP encryption is selected, this item allows selection of the WEP key to use for 802.11 communications. The terminal supports up to 4 keys. Press **[Select]** with “WEP Key” highlighted to begin selection. Press **[Next]** and **[Back]** until the desired key number is displayed. Press **[Select]** to complete selection.

WEP Key 1 through WEP Key 4:

If WEP encryption is selected, these items are used to set the contents of the WEP Keys. Press **[Select]** with the desired “WEP Key #” highlighted to begin key setting. The key entry field will be displayed. The keys must be set in hexadecimal format. Press **[Next]** and **[Back]** until the desired hexadecimal digit is displayed. Press **[Select]** to accept that digit and move to the next. Unused digits at the end of the key should be set to 0. Entry will automatically terminate after the last digit has been set.

WPA Key:

If WPA (TKIP or AES) encryption is selected, this item is used to set the contents of the WPA Key. Press **[Select]** with “WPA Key” highlighted to begin setting the key. The key entry field will be displayed. The keys must be set in hexadecimal format. Press **[Next]** and **[Back]** until the desired hexadecimal digit is displayed. Press **[Select]** to accept that digit and move to the next. Unused digits at the end of the key should be set to 0. Entry will automatically terminate after the last digit has been set.

NOTE  *Key lengths must be at least 8 characters (16 hexadecimal digits). WPA keys may be up to 32 characters in length, but the Power On Setup utility only supports setting of 8-16 character keys (up to 32 hexadecimal digits). Longer keys must be set by the application.*

8.4.7 COM1 and Any Additional Installed Serial Ports

NOTE  *If you have an optional secondary serial port, you will also see the “COM2” category. You should configure both COM1 and COM2 as described in this section.*

Some custom terminals may be configured with up to 10 serial ports. On these units, sections for COM1 through COM10 will appear in the menu. All serial ports are configured in a similar manner.

Use the following functions to configure your serial communications port(s).

Press **[Next]** or **[Back]** to move to **COM1** or **COM2** (or the desired port). Press **[Select]** and **[Next]** to move to each field. Press **[Select]** at each field to move to the field entry. Press **[Next]** or **[Back]** to select the appropriate entry at each field. Press **[Select]** to return to the function name.

Baud Rate:

Select the baud rate (600 – 115,200 bps).

Data Bits:

Select the number of data bits, **7** or **8**.

NOTE 

The serial port must be set to 8 data bits to support user application downloads or firmware upgrades.

Parity:

Select the parity setting, **N** (none), **O** (odd), or **E** (even).

Stop bits:

Select the number of stop bits, **1** or **2**.

Flow Ctrl:

Select the type of flow control, **None**, **SW** (XonXoff, software), or **RTS/CTS** (hardware). If using hardware flow control (HW), refer to the pinout table in “Serial Ports” section for the appropriate terminal. Some terminals may also support **DTR/DSR** (hardware) flow control.

Press **[Next]** or **[Back]** to move to the **DONE** section, and select **Save and Exit** to exit Power On Setup.

TX Timeout:

Select the maximum amount of time to wait to send, if flow control is being used, before a transmission error occurs (and thus terminates the transmission). This setting helps to keep the unit from hanging indefinitely while waiting to transmit if communication between the unit and its counterpart breaks down. The timeout is specified in the number of 20 ms ticks to wait.

Press **[Next]** or **[Back]** to move to the appropriate **COM**. Press **[Select]** and **[Next]** to move to the “TX Timeout” field. Press **[Select]** again to move to the first digit in the field. Press **[Next]** or **[Back]** to change the digit's value. Press **[Select]** to move to the next digit and press **[Next]** or **[Back]** to change it. Continue to press **[Select]** and change each digit in the TX Timeout as required. Press **[Select]** at the last digit to return to the Port field.

NOTE 

If you are using a keyboard, you can use the number keys (0-9) to enter the digits. If you are using a terminal with a keypad (24 or 40 key with standard Beijer Electronics legend), you can use the number keys (0-9) to enter the digits.

Protocol:

For terminals equipped with a serial multiport, use this function to select the desired serial protocol (EIA-232, EIA-422, or EIA-485).

Press **[Select]** and **[Next]** to move to **Protocol**, and press **[Select]** again to move to the options. Press **[Next]** or **[Back]** to select the desired protocol, then press **[Select]** to return to the function name.

NOTE  *The multiport protocol setting will change the signal levels on the serial port pins. To prevent potential damage to equipment, set the protocol setting to the desired level before attaching the terminal to external devices.*

Termination:

For terminals equipped with a serial multiport, this item will appear if the 485 protocol is selected. Use this function to enable or disable the EIA-485 termination network

Press **[Select]** and **[Next]** to move to **Termination**, and press **[Select]** again to move to the options. Press **[Next]** or **[Back]** to select **On** or **Off**, then press **[Select]** to return to the function name.

Failsafe:

For terminals equipped with a serial multiport, this item will appear if the 485 protocol is selected. Use this function to enable or disable the EIA-485 failsafe network, which pulls the signal lines to the passive signal levels when no device is driving the bus.

Press **[Select]** and **[Next]** to move to **Failsafe**, and press **[Select]** again to move to the options. Press **[Next]** or **[Back]** to select **On** or **Off**, then press **[Select]** to return to the function name.

8.4.8 Keypad

You will only see this category if your terminal is set up to use a keypad. The Keypad functions are used to turn the keyclick, key repeat and auto shift features on or off. The default state of the keypad backlight (if available) is also set in this section.

8.4.8.1 Keyclick

Use this function to turn the audible keyclick on or off. If “on,” you will hear a click when a key on the keypad is pressed.

Press **[Next]** or **[Back]** to move to **KEYPAD**. Press **[Select]** to move to **Keyclick**, and press **[Select]** again to move to the options. Press **[Next]** or **[Back]** to select **On** or **Off**, then press **[Select]** to return to the function name.

Press **[Next]** or **[Back]** to move to the **DONE** section, and select **Save and Exit** to exit Power On Setup.

8.4.8.2 Key Repeat

Use this function to turn the key repeat feature on or off. If “on,” a key entry repeats if you hold down the key on the keypad.

Press **[Next]** or **[Back]** to move to **KEYPAD**. Press **[Select]** and then **[Next]** to move to **Key Repeat**, and press **[Select]** again to move to the options. Press **[Next]** or **[Back]** to select **On** or **Off**. Press **[Select]** to return to the function name.

If you selected **On**, you will see two additional functions, as described in the following sections.

Press **[Next]** or **[Back]** to move to the **DONE** section, and select **Save and Exit** to exit Power On Setup.

8.4.8.3 Rpt Delay

You will only see this function if you selected **On** at the “Key Repeat” field (see [section 8.4.8.2](#)). Use this function to select the delay time that you want between when a key is pressed and when it begins to repeat automatically.

Press **[Next]** to move to **Rpt Delay**, and press **[Select]** to move to the options. Press **[Next]** or **[Back]** to select the key repeat delay time in milliseconds. The time increments or decrements by 20 ms each time you press **[Next]** or **[Back]**. Press **[Select]** to return to the function name.

Press **[Next]** or **[Back]** to move to the **DONE** section, and select **Save and Exit** to exit Power On Setup.

8.4.8.4 Rpt Rate

You will only see this function if you selected **On** at the “Key Repeat” field (see [section 8.4.8.2](#)). Use this function to select the time that you want between each repeat when a key begins to repeat automatically.

Press **[Next]** to move to **Rpt Rate**, and press **[Select]** to move to the options. Press **[Next]** or **[Back]** to select the key repeat rate in milliseconds. The rate increments or decrements by 20 ms each time you press **[Next]** or **[Back]**. Press **[Select]** to return to the function name.

Press **[Next]** or **[Back]** to move to the **DONE** section, and select **Save and Exit** to exit Power On Setup.

8.4.8.5 AutoShift

When AutoShift is enabled, the system software will automatically handle the Shift function of the keypad, i.e., when the Shift key is pressed, the Shift LED is lit and subsequent key presses will return shifted key codes to the Qlarity application. Set AutoShift to **Off** to disable this automatic shift behavior. When AutoShift is disabled, pressing the Shift key will generate normal key messages, and the Shift LED may be manipulated using the SetLED API.

Press **[Next]** to move to **AutoShift**, then press **[Select]** to move to the options. Press **[Next]** or **[Back]** to select **On** or **Off**. Press **[Select]** to return to the function name.

Press **[Next]** or **[Back]** to move to the **DONE** section, and select **Save and Exit** to exit Power On Setup.

8.4.8.6 AutoPower

When AutoPower is enabled, the terminal will enter a low power sleep mode when the Power key on the keypad is pressed. If asleep, pressing the Power key awakens the terminal and resumes program execution. Set AutoPower to **Off** to disable this behavior. When AutoPower is disabled, pressing the Power key will generate normal key messages, and the Power LED may be manipulated using the SetLED API.

Press **[Next]** to move to **AutoPower**, then press **[Select]** to move to the options. Press **[Next]** or **[Back]** to select **On** or **Off**. Press **[Select]** to return to the function name.

Press **[Next]** or **[Back]** to move to the **DONE** section, and select **Save and Exit** to exit Power On Setup.

8.4.8.7 Keypad Backlight

This section will only appear if your terminal includes a keypad backlight. Use this function to set the default state of the keypad backlight (at power on). Select **On** to turn the keypad backlight on when the power is applied to the unit, or select **Off** to turn the keypad backlight off when the power is applied.

Press **[Next]** to move to **BACKLIGHT** in the **KEYPAD** section, then press **[Select]** to move to the options. Press **[Next]** or **[Back]** to select **On** or **Off**. Press **[Select]** to return to the function name.

Press **[Next]** or **[Back]** to move to the **DONE** section, and select **Save and Exit** to exit Power On Setup.

8.4.9 Keyboard

You will only see this category if you have a keyboard connected to the terminal. The Keyboard functions are used to set the key repeat delay time and rate.

8.4.9.1 Rpt Delay

Use this function to select the delay time that you want between when a key is pressed and when it begins to repeat automatically.

Press **[Next]** to move to **Rpt Delay**, and press **[Select]** to move to the options. Press **[Next]** or **[Back]** to select the key repeat delay time. The choices are: 250, 500, 750, or 1000 milliseconds. Press **[Select]** to return to the function name.

Press **[Next]** or **[Back]** to move to the **DONE** section, and select **Save and Exit** to exit Power On Setup.

8.4.9.2 Rpt Rate

Use this function to select the time that you want between each repeat when a key begins to repeat automatically.

Press **[Next]** to move to **Rpt Rate**, and press **[Select]** to move to the options. Press **[Next]** or **[Back]** to select the key repeat rate. The choices range from 2.0 to 30.0 characters per second (cps). The default is 6 cps. Press **[Select]** to return to the function name.

Press **[Next]** or **[Back]** to move to the **DONE** section, and select **Save and Exit** to exit Power On Setup.

8.4.10 Sound

This section only appears if the audio decoder option has been installed.

8.4.10.1 Volume

Set the master volume of the speaker. This affects volume of sounds played by the PlaySound API as well as that of the PlayNote API. (Exception: on QTERM-G55 terminals, only the PlayNote API is affected by the volume setting.)

Press **[Next]** or **[Back]** to move to **SOUND**. Press **[Select]** and then press **[Select]** again to move to the **Volume** setting. Press **[Next]** or **[Back]** until the volume is at the desired level. A tone will be played with each press to indicate the current volume.

8.4.10.2 Note Amplitude

Set the volume of beeps played by calls to PlayNote on units that include the optional audio decoder.

Press **[Next]** or **[Back]** to move to **SOUND**. Press **[Select]** and then press **[Next]** again to move to the **Note Amp** setting. Press **[Select]** again to start setting the note amplitude. Press **[Next]** or **[Back]** until the volume is at the desired level. A tone will be played with each press to indicate the current volume.

8.4.11 Feedback

The feedback functionality controls how the unit reports development information and fatal errors. Any combination of COM1, Display, USB, and UDP (Ethernet, if available) can be selected.

8.4.11.1 Serial

Use this function to enable or disable feedback to the primary serial (COM1) interface.

Press **[Select]** and **[Next]** to move to **Serial**, and press **[Select]** again to move to the options. Press **[Next]** or **[Back]** to select **On** or **Off**, then press **[Select]** to return to the function name.

Press **[Next]** or **[Back]** to move to the **DONE** section, and select **Save and Exit** to exit Power On Setup.

8.4.11.2 Video

Use this function to enable or disable feedback to the display.

Press **[Select]** and **[Next]** to move to **Video**, and press **[Select]** again to move to the options. Press **[Next]** or **[Back]** to select **On** or **Off**, then press **[Select]** to return to the function name.

Press **[Next]** or **[Back]** to move to the **DONE** section, and select **Save and Exit** to exit Power On Setup.

8.4.11.3 USB

Use this function to enable or disable feedback to the USB device communications interface.

Press **[Select]** and **[Next]** to move to **USB**, and press **[Select]** again to move to the options. Press **[Next]** or **[Back]** to select **On** or **Off**, then press **[Select]** to return to the function name.

NOTE 

Feedback via the USB device communications interface requires installation of the Beijer Electronics USB Communications drivers and a PC host application to gather and display the feedback. Contact Beijer Electronics Technical Support for additional details.

Press **[Next]** or **[Back]** to move to the **DONE** section, and select **Save and Exit** to exit Power On Setup.

8.4.11.4 UDP

Use this function to enable or disable feedback to the network interface via the UDP protocol. If this option is enabled, you should also set the desired IP address and port number to receive the feedback (see Addr and Port Number below).

Press **[Select]** and **[Next]** to move to UDP, and press **[Select]** again to move to the options. Press **[Next]** or **[Back]** to select **On** or **Off**, then press **[Select]** to return to the function name.

Press **[Next]** or **[Back]** to move to the **DONE** section, and select **Save and Exit** to exit Power On Setup.

8.4.11.5 Addr

Use this function to set the IP address to send UDP packets to for feedback.

Press **[Next]** or **[Back]** to move to **FEEDBACK**. Press **[Select]** and **[Next]** to move to the “UDP” field. Press **[Select]** again to move to the first digit in the “UDP” field. Press **[Next]** or **[Back]** to change the digit's value.

Press **[Select]** to move to the next digit and press **[Next]** or **[Back]** to change it. Continue to press **[Select]** and change each digit in the address as required. Press **[Select]** at the last digit to return to the UDP field.

NOTE  *If you are using a keyboard, you can use the number keys (0-9) to enter the digits.*

Press **[Next]** or **[Back]** to move to the **DONE** section, and select **Save and Exit** to exit Power On Setup.

8.4.11.6 Port Number

Use this function to set the port number to send UDP feedback packets to.

Press **[Next]** or **[Back]** to move to **FEEDBACK**. Press **[Select]** and **[Next]** to move to the “Port” field. Press **[Select]** again to move to the first digit in the “Port” field. Press **[Next]** or **[Back]** to change the digit's value. Press **[Select]** to move to the next digit and press **[Next]** or **[Back]** to change it. Continue to press **[Select]** and change each digit in the Port number as required. Press **[Select]** at the last digit to return to the Port field.

NOTE  *If you are using a keyboard, you can use the number keys (0-9) to enter the digits.*

Press **[Next]** or **[Back]** to move to the **DONE** section, and select **Save and Exit** to exit Power On Setup.

8.4.12 Miscellaneous

The Miscellaneous functions include the setting up of a password for Power On Setup and also a unit information display screen.

8.4.12.1 Information

Use this function to determine the current version of firmware, current BFF version, minimum BFF version, amount of RAM, amount of flash memory, the current flash file system size, and Ethernet MAC address of the unit.

Press **[Next]** or **[Back]** to move to **MISCELLANEOUS**. Press **[Select]** to move to **Information**, and press **[Select]** again to view this data.

Press any key to exit this screen and return to the function name.

Press **[Next]** or **[Back]** to move to the **DONE** section, and select **Save and Exit** to exit Power On Setup.

8.4.12.2 Use Password

Use this function to determine whether or not a password is required to access the Power On Setup utility.

Press **[Next]** or **[Back]** to move to **MISCELLANEOUS**. Press **[Select]** to move to **Use Password**, and press **[Select]** again to move to the options. Press **[Next]** or **[Back]** to select **Yes** or **No**, then press **[Select]** to return to the function name.

If you selected **Yes**, the “Change Password” function appears for you to define the password, as described in the following section.

Press **[Next]** or **[Back]** to move to the **DONE** section, and select **Save and Exit** to exit Power On Setup.

8.4.12.3 Change Password

You will only see this function if you selected **Yes** at the “Use Password” field. Use this function to set up or change the Power On Setup password (see [section 8.4.12.2](#)).

Press **[Next]** to move to **Change Password**, and press **[Select]**. The “Enter Password” prompt and the arrow keys (↑ ↓ ← →) with the **[Select]** key in the center are displayed.

Press a series of arrow keys in the order they must be entered as the password (e.g., ↑↑→→). An asterisk (*) appears in the “Enter Password” prompt for each arrow you press. When you have finished entering the password, press **[Select]** (in the center of the display). The “Confirm New Password” box is displayed.

Enter the password a second time to confirm it. The message, “Password will be changed on exit with save” is displayed.

Press **[Next]** or **[Back]** to move to the **DONE** section, and select **Save and Exit** to exit Power On Setup. The next time you access Power On Setup, the new password will be required.

8.4.13 Diagnostics

You will only see this category if your terminal is set up to use a keypad or keyboard. Use the Diagnostics functions to verify that a keypad or keyboard key is working properly.

NOTE  *Because the <Enter> key is required to exit Diagnostics, you cannot test it. All other keys may be tested.*

8.4.13.1 Keypad Key

Use this function to verify that keypad keys are mapped correctly on the terminal.

Press → or ← to move to **DIAGNOSTICS**. Press <Enter> to move to **Keypad Key**, and press <Enter> again. Press the key on the keypad that you want to test. The location (row and column) of the key that you pressed is displayed so that you can verify that it is correct. Press each key that you want to test. Press <Enter> to end diagnostics.

Press → or ← to move to the **DONE** section, and select **Save and Exit** to exit Power On Setup.

8.4.13.2 Keybrd Key

You will only see this function if you have a keyboard connected to your terminal. Use this function to verify that keyboard keys are mapped correctly on the terminal.

Press → or ← to move to **DIAGNOSTICS**. Press <Enter> to move to **Keybrd Key**, and press <Enter> again. Press the key on the keyboard that you want to test. The character that is mapped to the key you pressed is displayed, along with the decimal scan code in parenthesis. Press each key that you want to test. To test mapping of key combinations, press <Shift>, <Ctrl>, or <Alt> (as applicable) with the appropriate key.

Press <Enter> to end diagnostics and return to the function name.

Press → or ← to move to the **DONE** section, and select **Save and Exit** to exit Power On Setup.

8.4.13.3 Transmit Key

Use this function to send the results of the “Keypad or Keyboard Key” test through the COM1 port.

Press → or ← to move to **DIAGNOSTICS**. Press <Enter> and then → to move to **Transmit Key**, and press <Enter> to move to the options. Press → or ← to select **Yes** or **No**, then press <Enter> to return to the function name.

Press → or ← to move to the **DONE** section, and select **Save and Exit** to exit Power On Setup.

8.4.13.4 SDRAM Test

Some Qlarity-based terminals include the ability to do a comprehensive, non-destructive test on the synchronous DRAM memory. The contents of memory and the processor state are unharmed by the test.

Press **[Next]** to move to **SDRAM TEST**. Press **[Select]** to execute the test. A small dialog will appear indicating that the test is in process. When the test is completed (typically a few seconds) the dialog will change to indicate success or failure. Contact the Service Department at Beijer Electronics if you terminal reports a failure.

8.4.14 Done

Use the Done functions to exit Power On Setup with or without saving your changes.

8.4.14.1 Save and Exit

Press **[Next]** or **[Back]** to move to **DONE**. Press **[Select]** to move to **Save and Exit**, and press **[Select]** again to save your changes and exit Power On Setup. All changes that were made while in the Power On Setup utility are saved and reflected the next time the terminal is powered on.

NOTE  *Changes performed to the settings for “Erase FFS,” “Time,” and “Date” take effect immediately.*

8.4.14.2 Exit w/o Save

Press **[Next]** or **[Back]** to move to **DONE**. Press **[Select]** and then **[Next]** to move to **Exit w/o Save**, and press **[Select]** again **[Select]** to exit Power On Setup without saving the changes.

8.5 Touch Screen Calibration

If the touch screen is not working properly (e.g., if the touch keys do not work), it probably needs calibration. If you cannot navigate with the touch keys in the Power On Setup utility, do the following to switch the terminal to calibration mode and calibrate the touch screen without entering Power On Setup.

1. Turn off power to the terminal.
2. Press and hold the **[Calibrate]** touch area (see the illustrations in [section 8.1, “Using a Touch Screen”](#) for touch area locations) as you power on the terminal.
3. Continue pressing until the message, “TOUCHSCREEN CALIBRATION, Please press center of cross” is displayed and a “+” symbol appears on the screen.
4. Press the “+” symbol. The symbol moves to the bottom of the display.
5. Press the “+” symbol in its new location to complete calibration.

NOTE  *You can also calibrate the touch screen using the “Touchscreen” function in Power On Setup (see [section 8.4.3.4](#)).*

Notes