



Perfect Wireless Experience
完美无线体验

H350 for M2M LGA Series Hardware User Manual

Version : V1.0.9

Date : 2015.08.10



Copyright

Copyright ©2015 Fibocom Wireless Inc . All rights reserved.

Without the prior written permission of the copyright holder, any company or individual is prohibited to excerpt, copy any part of or the entire document, or transmit the document in any form.

Attention

The document is subject to update from time to time owing to the product version upgrade or other reasons. Unless otherwise specified, the document only serves as the user guide. All the statements, information and suggestions contained in the document do not constitute any explicit or implicit guarantee.

Trademark



The trademark is registered and owned by Fibocom Wireless Inc.

Versions

Version	Date	Remarks
V1.0.0	2013-09-03	Initial Version
V1.0.1	2013-09-11	Modified PIN description table
V1.0.2	2013-10-22	Modified tunable antenna level
V1.0.3	2013-12-18	Add H350-B50-10 description
V1.0.4	2014-12-26	<ol style="list-style-type: none">1. Add the related signal of POWER_ON and POWER_OFF;2. Delete the types of "A30" series, update operating temperature;3. Modify the description of POWER_ON, add the related AT commands; modify the design description of SIM card .
V1.0.5	2015-08-25	The company name is changed.
V1.0.6	2015-03-04	Modify the description of SIM_CD

V1.0.7	2015-04-21	Add the description of "Bottom(Perspective)" in PCB Layout ; Update the description of copyright and attention.
V1.0.8	2015-06-05	Update the description of the whole document; Modify the hardware diagram;
V1.0.9	2015-08-10	Update the fibocom logo.

Applicability Type

No .	Type	Note
1	H350-A50-00	

The difference of H350 series wireless module as listed below:

Model No .	GSM/GPRS/EDGE Band(MHz)	WCDMA Band(MHz)	HSDPA (Mbps)	HSUPA (Mbps)
H350-A50-00	900/1800	900/2100	21	5.76

Content

1 Foreword	6
1.1 Introduction	6
1.2 Reference Standards	6
2 Product Overview	8
2.1 Description	8
2.2 Specifications	8
2.3 Appearance	10
3 Structure	11
3.1 Dimension Diagram of Structure	11
3.2 PCB Layout Design	12
4 Hardware Introduction	13
4.1 Hardware Block Diagram	13
4.2 Pin Definition	14
4.2.1 Pin Map	14
4.2.2 Description of Pins	15
5 Hardware Interface	21
5.1 Power Interface	21
5.1.1 Power Supply	21
5.1.2 Power Consumption	21
5.1.3 VIO	23
5.1.4 VRTC	24
5.2 Power on/off and Reset Signal	25
5.2.1 Pin Definition of Power on/off Control Signal	25
5.2.2 Power on Signal	25
5.2.3 Power off Signal	26
5.2.4 Reset Signal	27
5.3 Status Indicating Signal	28
5.3.1 LPG Signal	28
5.3.2 SMI	28
5.3.3 WAKE_UP Signal	28
5.4 USB Interface	29
5.4.1 USB Interface Definition	29

5.4.2 USB Interface Application.....	29
5.5 UART Interface.....	31
5.5.1 UART Interface Description.....	31
5.5.2 UART Interface Application.....	32
5.5.3 Ring Indication.....	32
5.6 USIM Interface.....	33
5.6.1 USIM Pins.....	33
5.6.2 USIM Interface Design.....	33
5.6.2.1 “Normal Closed” SIM Card Circuit Design.....	33
5.6.2.2 “Normally Open” SIM Circuit Design.....	34
5.6.3 Points for Attention in USIM Design.....	35
5.6.4 USIM Hot-Plugging.....	35
5.6.4.1 Hardware Connection.....	35
5.6.4.2 Software Settings.....	36
5.7 Digital Audio.....	37
5.7.1 I2S.....	37
5.7.2 I2C.....	37
5.7.3 PCM Port Description.....	38
5.8 ADC Interface.....	38
5.9 Other Interfaces.....	38
6 Electrical and Environmental Features.....	39
6.1 Electrical Features.....	39
6.2 Environmental Features.....	39
7 RF Interface.....	40
7.1 Operating Frequency Band.....	40
7.1.1 Frequency Range of Antenna.....	40
7.2 RF PCB Design.....	40
7.2.1 Wiring Principle.....	40
7.2.2 Impedance Design.....	41
7.3 Antenna Design.....	41
7.3.1 Main Antenna Design Requirements.....	41

1 Foreword

1.1 Introduction

The document describes the electrical characteristics, RF performance, dimensions and application environment, etc. of H350 series wireless modules. With the assistance of the document and other instructions, developers can quickly understand the performance of H350 series wireless modules and develop products.

1.2 Reference Standards

The design of the product complies with the following standards:

- 3GPP TS 27.007 -v6.9.0: AT command set for User Equipment (UE)
- 3GPP TS 27.005 -v6.0.1: Use of Data Terminal Equipment -Data Circuit terminating Equipment (DTE-DCE) interface for Short Message Service (SMS) and Cell Broadcast Service (CBS)
- 3GPP TS 23.040 -v6.9.0: Technical realization of Short Message Service (SMS)
- 3GPP TS 24.011 -v6.1.0: Point- to - Point (PP) Short Message Service (SMS) support on mobile radio interface
- 3GPP TS 27.010 -v6.0.0: Terminal Equipment to User Equipment (TE-UE) multiplexer protocol
- 3GPP TS 27.060 -v6.0.0: Packet domain; Mobile Station (MS) supporting Packet Switched services
- 3GPP TS 25.304-v6.10.0: User Equipment (UE) procedures in idle mode and procedures for cell reselection in connected mode
- 3GPP TS 25.308 -v6.4.0: High Speed Downlink Packet Access (HSDPA); Overall description; Stage 2
- 3GPP TS 25.309 -v6.6.0: FDD enhanced uplink; Overall description; Stage 2
- 3GPP TS 23.038 -v6.1.0: Alphabets and language - specific information
- 3GPP TS 21.111 -v6.3.0: USIM and IC card requirements
- 3GPP TS 31.111 -v6.11.0 "USIM Application Toolkit (USAT)"
- 3GPP TS 45.002 -v6.12.0: Multiplexing and multiple access on the radio path
- 3GPP TS 51.014 -v4.5.0: Specification of the SIM Application Toolkit for the Subscriber Identity Module - Mobile Equipment (SIM-ME) interface

- 3GPP TS 51.010 -1 -v6.7.0: Mobile Station (MS) conformance specification; Part 1: Conformance specification
- 3GPP TS 22.004 -v6.0.0: General on supplementary services
- 3GPP TS 23.090 -v6.1.0: Unstructured Supplementary Service Data (USSD); Stage 2
- 3GPP TS 24.008 v6.19, Mobile radio interface Layer 3 specification;

2 Product Overview

2.1 Description

H350 series modules are 3G wireless modules with high integration density, supporting GSM/GPRS/ EDGE and UMTS/HSDPA/HSUPA/HSPA+.

2.2 Specifications

Specifications	
Operating Frequency Rang	UMTS (WCDMA) : 900/2100MHz
	GSM/GPRS/EDGE : 900/1800MHz
Data Rate	UMTS/HSDPA/HSUPA 3GPP release 7
	HSUPA 5.76Mbps (Cat 6)
	HSDPA 21Mbps (Cat 14) or 7.2Mbps (Cat 8)
	GSM 3GPP release 7
	EDGE (E-GPRS) multi-slot class 33(296kbps DL , 236.8kbps UL)
	GPRS multi-slot class 33(107kbps DL , 85.6kbps UL)
Physical Characteristics	Dimension : 29.8mm x 17.8mm x 2.00 mm
	Interface : LGA
	Weight : 2.5 grams
Environment	Operating Temperature: -30°C ~ +75°C
	Storage Temperature: -40°C ~ +85°C
Performance	
Operating Voltage	Voltage : 3.3V ~ 4.5V Normal : 3.8V
Current Consumption (Typical Value)	2mA (Sleep Mode)
	3G Idle : 13mA
	3G Talk : 500mA
	2G Talk : 260mA (GSM PCL5)
Tx Power (Typical Value)	Class 4 (2W) : 900 MHz, GSM
	Class 1 (1W) : 1800 MHz, GSM
	Class E2 (0.5W) : 900 MHz, EDGE
	Class E2 (0.4W) : 1800 MHz, EDGE

	Class 3 (0.25W) : 900/2100 MHz, WCDMA
Rx Sensitivity (Typical Value)	UMTS/HSPA : -109dBm
	GSM : -108dBm
Interface	
Radio Frequency Interface	Antenna
Function Interface	1 x USB 2.0 , 2 x UART , MUX Over UART1 , Multiple Profiles over USB
	SPI Support , I2C Support , I2S Support
	PCM , HSIC , GPIO , A/D , RTC
Data Features	
Protocol Stack	Embedded TCP/IP and UDP/IP protocol stack
EDGE	Multi-slot class 33 (5 Down; 4 Up; 6 Total)
	Coding Scheme MCS1~9
GPRS	Multi-slot class 33 (5 Down; 4 Up; 6 Total)
	Coding Scheme CS1~4
CSD	UMTS(14.4kbps) , GSM(9.6kbps)
USSD	Support
SMS	MO / MT Text and PDU modes
	Cell broadcast
Audio	Digital Audio
	Voice coders: EFR/HR/FR/AMR
Audio Frequency Control	Gain Control
Character Set	IRA , GSM , UCS2 , HEX
AT Commands	FIBOCOM proprietary AT commands
	GSM 07.05
	GSM 07.07
Accessories	Firmware Loader Tool over USB/UART
	User Manual
	Developer Kit

2.3 Appearance

The product appearance of H350 series wireless module is shown as below:

Top view:

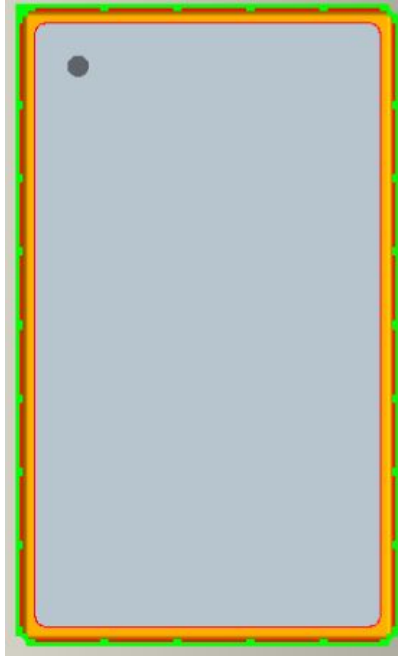

Figure 2- 1 Top View

Bottom view:

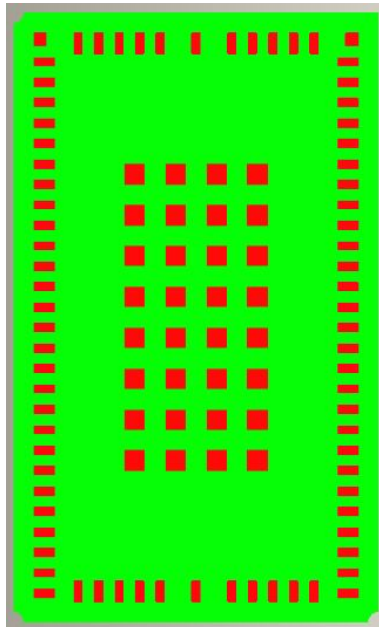

Figure 2- 2 Bottom View

3 Structure

3.1 Dimension Diagram of Structure

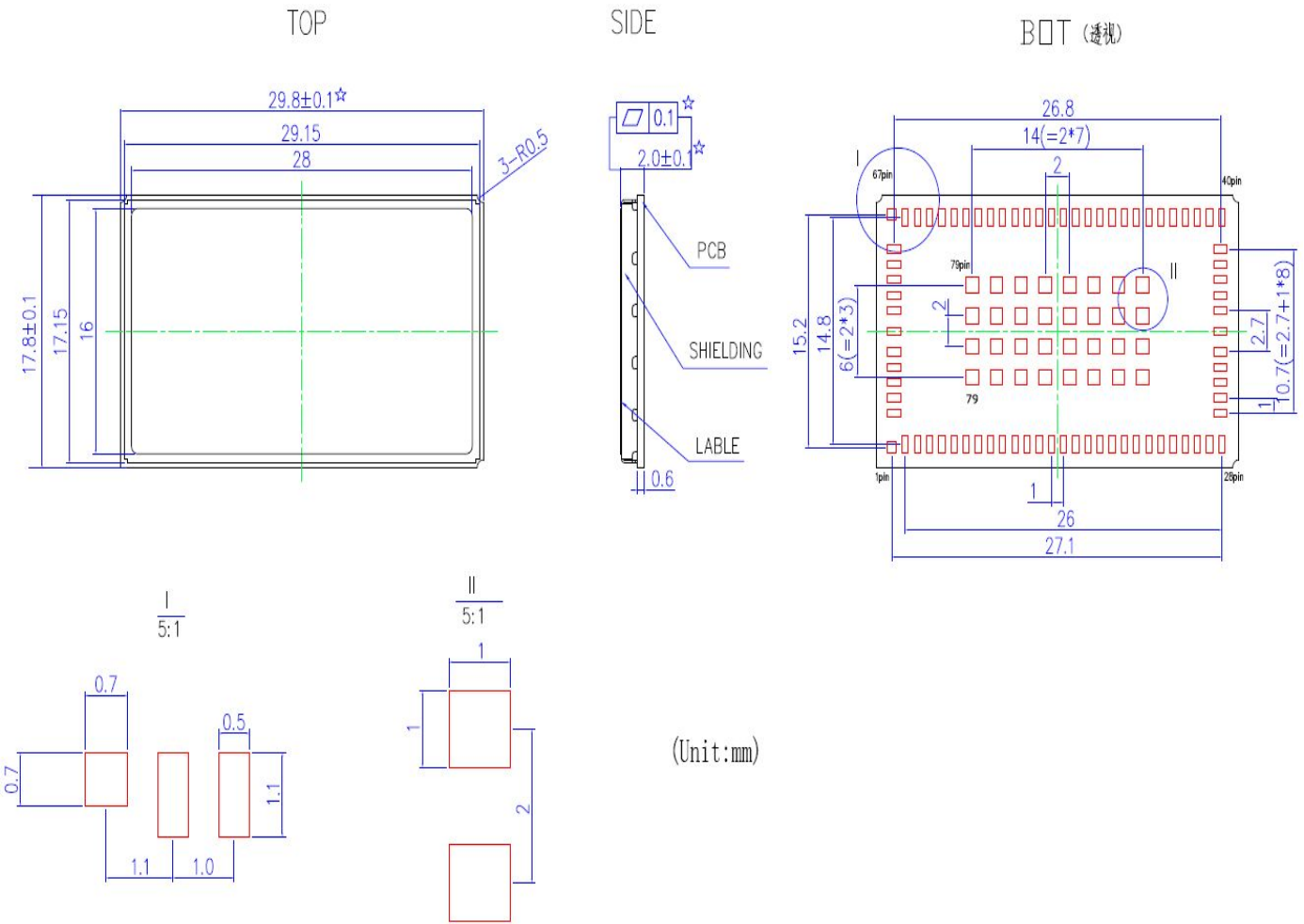

Figure 3- 1 Dimension Diagram of Structure

3.2 PCB Layout Design

H350 RECOMMENDED LAND PATTERN (Unit: mm)

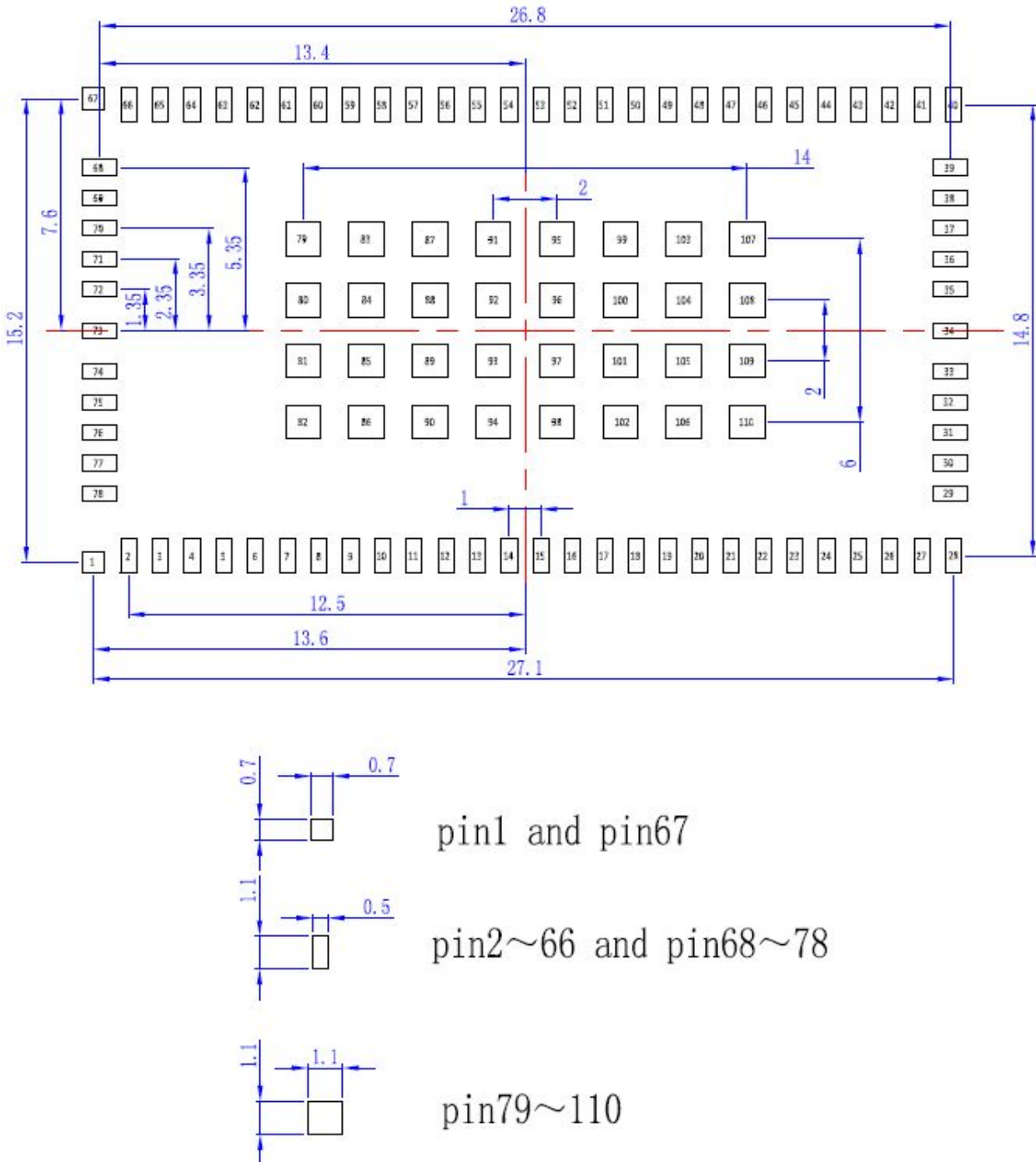

Figure 3- 2 Recommended PCB Layout

(Top View)

4 Hardware Introduction

4.1 Hardware Block Diagram

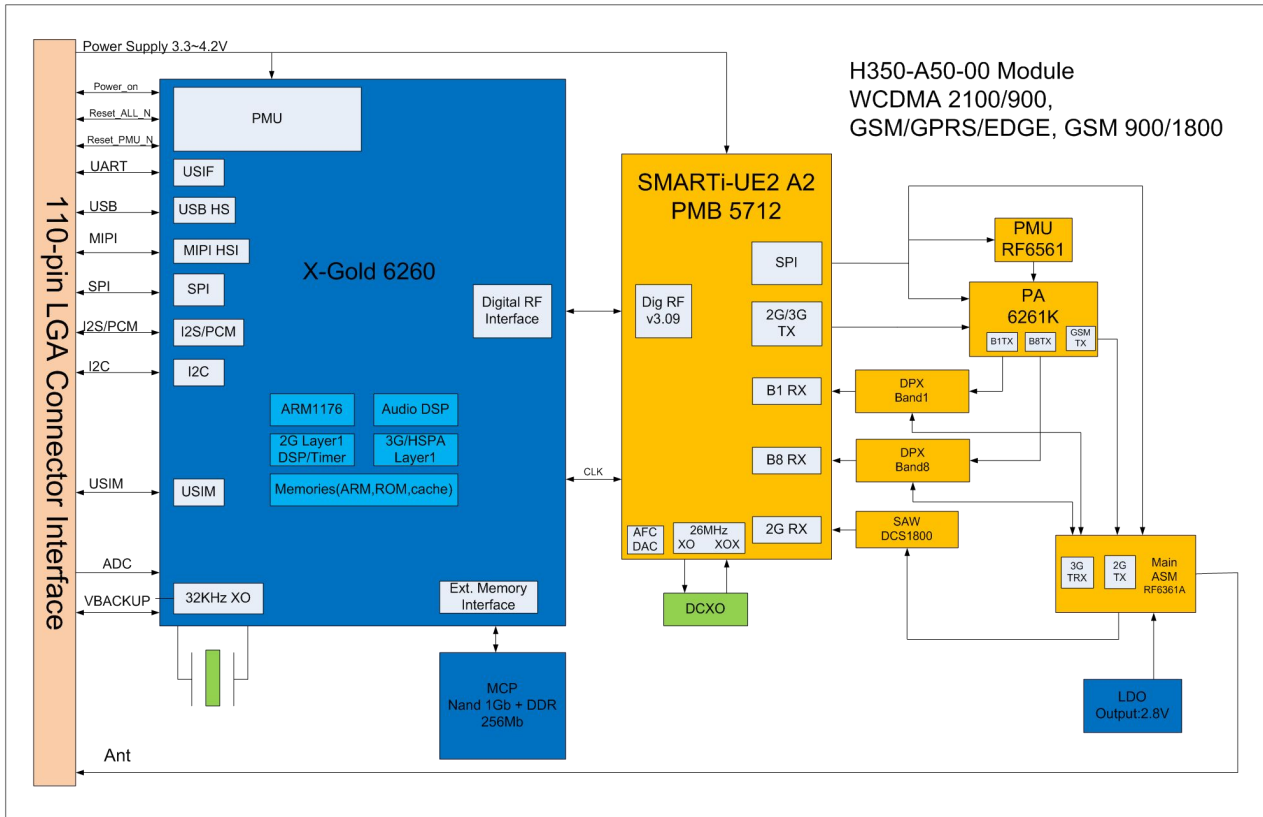
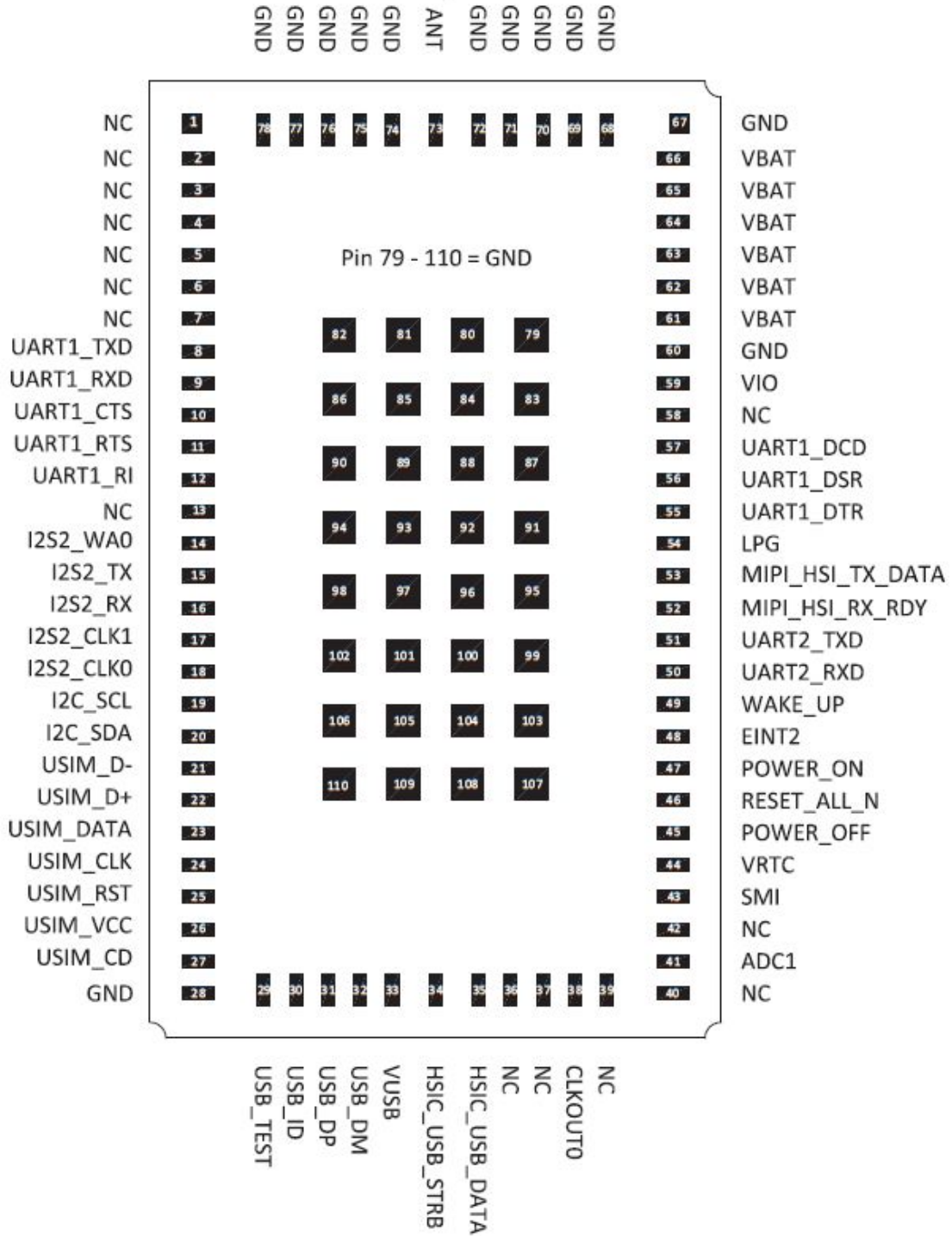

Figure 4-1 Block Diagram

4.2 Pin Definition

4.2.1 Pin Map



TOP (View)

Figure 4-2 Pin Diagram

4.2.2 Description of Pins

The logic signal level of H350 series is 1.8V. Pins of H350 series are described in the table below:

Pin#	Pin Name	I/O	Reset Value	Idle Value	Description
Power Supply					
61	VBAT	I			Main power supply, voltage range: 3.3V ~ 4.5V.
62	VBAT	I			
63	VBAT	I			
64	VBAT	I			
65	VBAT	I			
66	VBAT	I			
59	VIO	O			1.8V voltage output inside the modules.
44	VRTC	I/O			Backup battery input/output.
Power ON/OFF Signal					
45	POWER_OFF	I	PU	PU	Power off control signal, internal 4.7K pull-up resistor
47	POWER_ON	I	PU	PU	Power on control signal, internal 200K pull-up resistor
Reset Signal					
46	RESET_ALL_N	I	PU	PU	External reset signal input
USIM Interface					
27	USIM_CD	I	PU	PU	Insert USIM card to test; active low; Internal 390K pull-up resistor.
26	USIM_VCC	O			USIM card power supply: 1.8V or 3.3V.
25	USIM_RST	O	PP	PP	USIM card reset signal.
24	USIM_CLK	O	PP	PP	USIM card clock signal.
23	USIM_DATA	I/O	PU	PU	USIM card data signal, internal 4.7K pull-up resistor.

High Speed SIM Interface					
22	USIM_D+				High speed SIM card USB signal + (Temporarily not supported)
21	USIM_D-				High speed SIM card USB signal - (Temporarily not supported)
I ² S Interface					
17	I2S2_CLK1	O	PD	PD	I2S2 serial clock SCLK1
18	I2S2_CLK0	O	T	T	I2S2 serial clock SCLK0 (Default: CLK0)
14	I2S2_WA0	O	T	T	I2S2 field selection signal
15	I2S2_TX	O	T	T	I2S2 serial data output
16	I2S2_RX	I	T	T	I2S2 serial data input
USB Interface					
31	USB_DP	I/O			USB data signal+
32	USB_DM	I/O			USB data signal-
30	USB_ID	—			USB ID signal
33	VUSB	I			USB Power Input
29	USB_TEST	—			USB TEST signal
I ² C Interface					
20	I2C_SDA	I/O	PU	PU	I2C data signal line, Internal 1K pull-up resistor
19	I2C_SCL	O	PU	PU	I2C clock signal line, Internal 1K pull-up resistor.
UART1					
12	UART1_RI	O	L	L	UART1 Ring Indicator
56	UART1_DSR	I	T	T	UART1 DTE Ready
55	UART1_DTR	O	L	H	UART1 DCE Ready
57	UART1_DCD	O	L	L	UART1 Carrier Detect

10	UART1_CTS	I	PU	PU	UART1 Clear To Send
11	UART1_RTS	O	L	L	UART1 Request To Send
8	UART1_TXD	O	PP	PP	UART1 Transmitted Data
9	UART1_RXD	I	PU	PU	UART1 Received Data
UART2					
51	UART2_TXD	O	PP	PP	UART2 Transmitted Data
50	UART2_RXD	I	PU	PU	UART2 Received Data
ADC					
41	ADC1	I			ADC1, input voltage range:0~1.2V
EINT					
49	WAKE_UP	I	PU	PU	Interrupt of external wake-up, active low.
48	EINT2	I	PU	PU	External interrupt, active low.
USB HSIC					
35	HSIC_USB_DATA				HSIC USB data signal line (not supported yet)
34	HSIC_USB_STRB				HSIC USB pulse signal line (not supported yet)
Antenna					
73	ANT	I/O			Main antenna interface, impedance requirement: 50 ohm.
Others					
38	CLKOUT0	O	PP	PP	Digital audio clock output
43	SMI	O	L		Sleep Mode Indicator
54	LPG	O			Status indicator
52	MIPI_HSI_RX_RDY	I			MIPI signal (not supported yet)
53	MIPI_HSI_TX_DATA	O			MIPI signal (not supported yet)

NC					
1	NC				
2	NC				
3	NC				
4	NC				
5	NC				
6	NC				
7	NC				
13	NC				
36	NC				
37	NC				
39	NC				
40	NC				
42	NC				
58	NC				
GND					
28	GND				
60	GND				
67	GND				
68	GND				
69	GND				
70	GND				
71	GND				
72	GND				
74	GND				
75	GND				

76	GND				
77	GND				
78	GND				
79	GND				
80	GND				
81	GND				
82	GND				
83	GND				
84	GND				
85	GND				
86	GND				
87	GND				
88	GND				
89	GND				
90	GND				
91	GND				
92	GND				
93	GND				
94	GND				
95	GND				
96	GND				
97	GND				
98	GND				
99	GND				
100	GND				
101	GND				

102	GND				
103	GND				
104	GND				
105	GND				
106	GND				
107	GND				
108	GND				
109	GND				
110	GND				

H : High Voltage Level

L : Low Voltage Level

PD : Pull-Down

PU : Pull-Up

T : Tristate

OD : Open Drain

PP : Push-Pull

5 Hardware Interface

5.1 Power Interface

5.1.1 Power Supply

H350 modules require 3.3V~4.5V direct current power supply, which can provide the maximum GSM emission current of 2A.

Input power supply requirements:

Parameter	Minimum Value	Recommended Value	Maximum Value	Unit
VBAT	3.3	3.8	4.5	V

Points for attention in design:

1. Supply voltage fluctuation shall be lower than 300mV.
2. Minimum supply voltage drop shall be higher than 3.3V.

Filter capacitor of supply circuit is designed as follows:

Recommended capacitor	Application	Description
1000uF	Supply capacitance	Reduce power-supply fluctuation during phone call. The capacitance value bigger is better
10nF, 100nF	Digital signal noise	Filter the interference caused by clock and digital signals
8.2pF, 10pF	1800/1900/2100 MHz	Filter RF interference
33pF, 39pF	850/900 MHz	Filter RF interference

5.1.2 Power Consumption

The power consumption as listed below:

Parameter	Description	Condition	Typical Value	Unit
I _{off}	RTC mode		68.0	uA

I _{idle}	Idle mode(GSM)	MFRMS	5	12.1	mA				
	WCDMA	DRX	8	12.5	mA				
I _{sleep}	Low power mode (GSM)	DRX	2	1.9	mA				
			5	1.5	mA				
			9	1.5	mA				
	Low power mode (WCDMA)	DRX	6	1.8	mA				
			8	1.8					
			9	1.7					
I _{GSM-RMS}	GSM voice RMS Current	EGSM900 PCL	5	246.7	mA				
			10	91.9					
			15	61.2					
			19	57.2					
		DCS1800 PCL	0	172.2					
			5	82.1					
			10	60.3					
			15	57.9					
			I _{GSM-MAX}	GSM voice Peak current		EGSM900 PCL	5	1738.8	mA
							10	415.9	
15	135.3								
19	124.2								
DCS1800 PCL	0	1012.9							
	5	348.7							
	10	141.5							
	15	110.3							
GPRS	EGSM900 PCL=5	GPRS -1Rx slot TX slot	1	247.9	mA				
			4	373.7					
	EGSM900 PCL=10	GPRS -1Rx slot TX slot	1	89.0					
			4	220.3					
	DCS1800 PCL=0	GPRS -1Rx slot	1	172.4					

		TX slot	4	259.8	
	DCS1800 PCL10	GPRS -1Rx slot	1	60.3	
		TX slot	4	101.2	
EGPRS-RMS	EGSM900 PCL=8	GPRS -1Rx slot	1	165.2	mA
		TX slot	4	493.2	
	EGSM900 PCL=15	GPRS -1Rx slot	1	61.5	
		TX slot	4	107.7	
	DCS1800 PCL=2	GPRS -1Rx slot	1	174.9	
		TX slot	4	514.3	
	DCS1800 PCL=10	GPRS -1Rx slot	1	67.7	
		TX slot	4	109.6	
IWCDMA-RMS	WCDMA	Band1	24dBm	442.0	mA
			0dBm	131.2	
			-24dBm	120.6	
			-50dBm	118.7	
		Band8	24dBm	421.9	
			0dBm	128.6	
			-24dBm	121.8	
			-50dBm	120.2	

5.1.3 VIO

As the power supply for the digital circuit inside the module, VIO can be used as the status indicator for the module.

VIO can be used as the reference level of the module' s digital signals.

Parameter	Minimum Value	Recommended Value	Maximum Value	Unit
VIO in operation	1.773	1.8	1.827	V

5.1.4 VRTC

VRTC is the power supply of the RTC inside the module, and it can be used as the backup power signal as well.

Parameters	Minimum Value	Recommended Value	Maximum Value	Unit
VRTC output voltage	1.71	1.8	1.89	V
VRTC input voltage (RTC is in normal)	0.5	1.8	1.89	V
VRTC input current (RTC is in normal)			1.0	uA

The reference design of VRTC circuit is as follows:

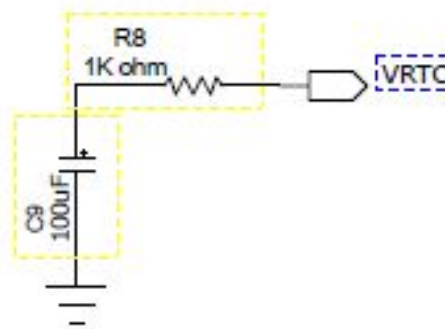

Figure 5- 1 VRTC Reference Design

Note:

- R8 is a current-limiting resistor, used to ensure the VRTC module works properly, free from being affected by peripheral circuits. $R8 \geq 1k \text{ ohm}$
- VRTC power consumption current $< 2\mu\text{A}$
- The value of C9 will affect the retaining time of RTC after VBAT powers off. The retaining time of RTC can be roughly calculated by the following formula:
 $T = (1.8 - 0.5) * C / I = 1.3C$, unit: second. Namely, if the value of C9 is 100uF, the retaining time of RTC will be around 130s.
- If the RTC backup power function is not required ,VRTC pin can be floating.

5.2 Power on/off and Reset Signal

5.2.1 Pin Definition of Power on/off Control Signal

H350 wireless modules provide three control signals to start up, shut down, and reset the modules. Pins definition as listed below :

Pin#	Pin Name	Electrical Level	Description
45	POWER_OFF	CMOS 1.8V	Power off signal
47	POWER_ON	CMOS 1.8V	Power on signal
46	RESET_ALL_N	CMOS 1.8V	External reset signal input

5.2.2 Power on Signal

After the module is connected to the power supply, the user can start up the module by setting low POWER_ON signal low. Timing sequence requirement of the startup pulse:

Parameter	Condition	Minimum Value	Typical Value	Maximum Value	Unit
Pulse Width		100	300	3000	ms

The timing sequence control is shown in the diagram below:

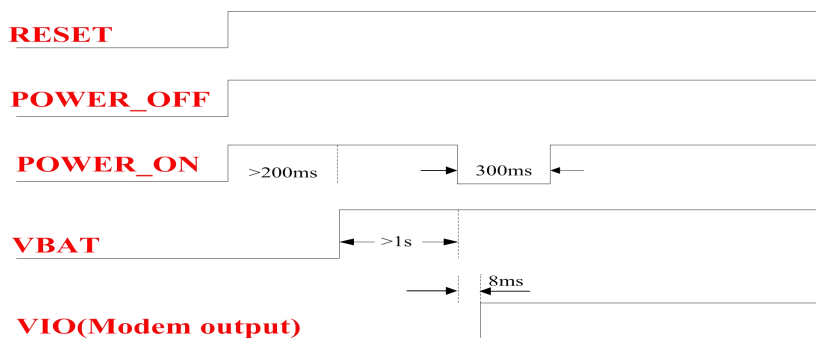

Figure 5-2 Timing Control

The recommended design of POWER_ON signal is as follows:

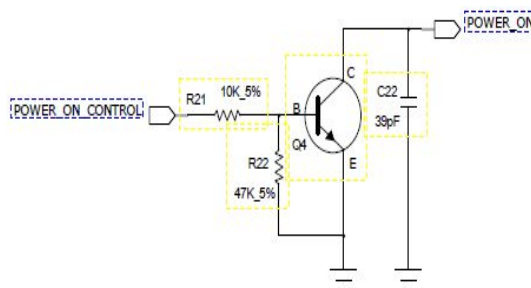

Figure 5-3 POWER_ON Reference Design

5.2.3 Power off Signal

H350 module supports two power_off modes. Through the software modes to turn off the module in general condition. If the system halted or happened exceptions, use the following hardware modes to turn off it, pull down the POWER_OFF signal. For details as listed below:

Off modes	Methods	Condition
Software off	Send AT+CPWROFF commands.	Normal power_off
Hardware off	Pull down the POWER_OFF signal.	Only used for system halted or happens exceptions and the software modes cannot be used.

The description of hardware power_off as follows (Pull down the POWER_OFF# signal or floating) : While pulling down the POWER_OFF# signal or floating, the modules` PMU (Power Management Unit) will be reset, then the module will get into off modes from working modes.

The timing sequence requirements of the pulse are as follows:

Parameter	Condition	Minimum Value	Typical Value	Maximum Value	Unit
Pulse Width		100	300	3000	ms

The timing sequence diagram as follows:

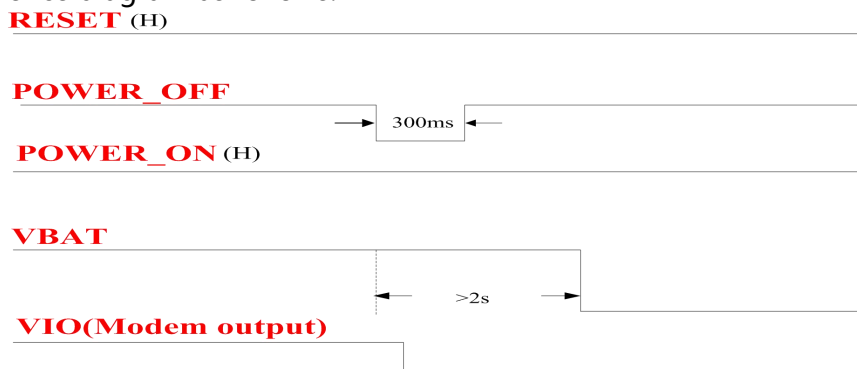

Figure 5-4 Power off Timing Control Diagram

The recommended design of POWER_ OFF signal is as follows:

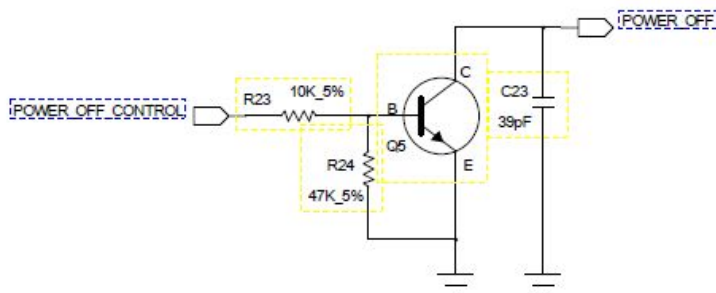

Figure 5-5 Recommended Design of POWER_OFF# Signal

5.2.4 Reset Signal

H350 wireless modules support external reset function. It is feasible to reset the module back to the original state by the Reset Signal.

When setting the Reset Signal low for 100ms, the module will be reset and restarted. When the user uses the Reset_N function, the PMU inside the module will not lose power.

Note: Reset signal is a sensitive signal line. In designing PCB layout, please keep the line away from RF interference, and make it well wrapped with ground wire. And it is advised to add an anti-shaking capacitor at the place close to the module end. At the same time, Reset_N signal line shall avoid the PCB edge and the surface, then reset the ESD can be avoided.

The timing sequence requirements of its pulse are as follows:

Parameter	Condition	Minimum Value	Typical Value	Maximum Value	Unit
Pulse Width		100	300	3000	ms

Recommended design:

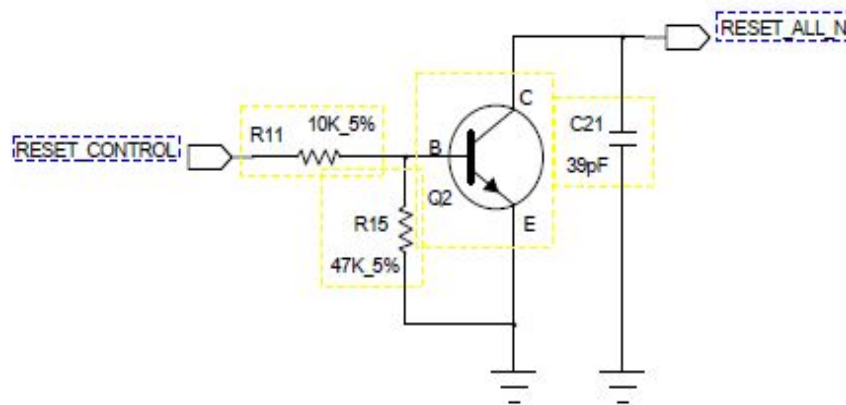

Figure 5-6 Recommended Design of Reset Circuit

5.3 Status Indicating Signal

The pins of status indicating signal as listed below:

Pin#	Pin Name	Description
54	LPG	LPG status Indicating
43	SMI	Sleep Mode Indicator
49	WAKE_UP	Sleep wake-up pin

5.3.1 LPG Signal

LPG signal description as listed below :

Status	Mode
idle(未注册)	600ms high level, 600ms low level
idle(已注册)	75ms high level, 3s low level
语音通信中 (Call)	low level
数据通信中	75ms high level, 75ms low level
Sleep(睡眠模式)	high level

Note: High level voltage is 1.8V.

5.3.2 SMI

SMI signal description as listed below :

Modes	Description
Sleep Mode	2.5S High; 100ms Low,repeat this
Other Mode	low level

5.3.3 WAKE_UP Signal

WAKE_UP signal description as listed below :

Module Mode	WAKE_UP Signal	Description
Sleep	Low level	Wake up the module from Sleep mode to Idle mode
	High level	Keep the module in Sleep mode
Idle/Call	Low level	Keep the module in Idle/Call mode
	High level	The module will not get into Sleep mode

5.4 USB Interface

5.4.1 USB Interface Definition

Pin#	Pin Name	I/O	Description
31	USB_DP	I/O	USB signal+
32	USB_DM	I/O	USB signal-
30	USB_ID	—	USB ID signal (NC is recommended)
33	VUSB	I	USB power input
29	USB_TEST	—	USB TEST signal(NC is recommended)

H350 wireless modules support USB 2.0. Before connecting it to PC, it is necessary to install the related USB driver.

After inserting the H350 wireless modules to PC, the USB interface will work with the driver and map seven ports on PC, as follows:

- One 3G Modem/AT port for initiating data traffic
- Three ports for dispatching AT Command
- One ports for capturing LOG information of the software
- Two port reserved for future use

5.4.2 USB Interface Application

Reference Circuit Design:

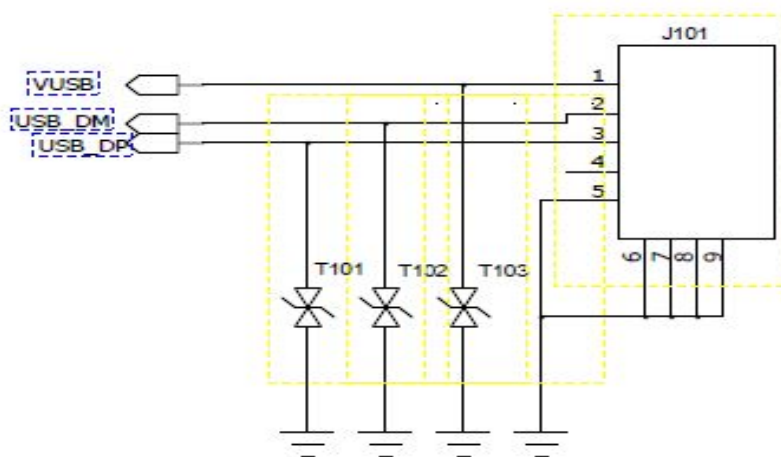

Figure 5- 7 USB Interface Reference Circuit Design

T101 and T102 shall be TVS with capacitance lower than 1pF; there is no specific limitation for the

capacitance of T103.

VUSB pin supplies power for USB. The recommended power supply range is 2.5V ~ 5.25V. In designing VUSB, there must be input, or it cannot recognize USB port.

USB_DP and USB_DM are the high-speed differential signal line, and their highest transmission rate is 480Mbps. The following requirements should be followed in designing PCB layout.

- USB_DP and USB_DM signal lines should have the same length, and should be parallel; avoid right angle wiring;
- USB_DP and USB_DM signal lines should be wrapped with GND at the ends.
- USB2.0 differential signal line should be laid at the signal layer closest to the ground layer.
- Ensure impedance matching; impedance is required to be 90ohm.

5.5 UART Interface

5.5.1 UART Interface Description

H350 wireless modules provide two UART for the users; one is standard 8-line serial port, and the other 2-line serial port.

The 8-line serial port UART1 supports full serial port mode with flow control function, and all the AT commands. Users can download software or receive and dispatch AT through UART1. The 2-line serial port UART2 only supports part of the AT commands.

Note:

- UART2 only supports the ordinary query function.
- UART2 does not support the hardware flow control, there are not the following pins : CTS, RTS, DTR, DSR, DCD, RI .
- UART2 does not support the MUX function.

UART1			
Pin#	Pin Name	I/O	Description
12	UART1_RI	O	UART1 Ring Indicator
56	UART1_DSR	I	UART1 DTE Ready
55	UART1_DTR	O	UART1 DCE Ready
57	UART1_DCD	O	UART1 Carrier Detect
10	UART1_CTS	I	UART1 Clear to send
11	UART1_RTS	O	UART1 Request to send
8	UART1_TXD	O	UART1 Transmitted Data
9	UART1_RXD	I	UART1 Received Data
UART2			
Pin#	Pin Name	I/O	Description
50	UART2_RXD	I	UART2 Received Data
51	UART2_TXD	O	UART2 Transmitted Data

5.5.2 UART Interface Application

Connect UART1 of H350 wireless module (DCE) to PC, and the signal direction of (DTE) is as follows:

MCU (DTE) application	Signal Direction	H350 module (DCE)
RXD		UART1_TXD
TXD		UART1_RXD
RTS		UART1_CTS
CTS		UART1_RTS
DSR		UART1_DTR
DTR		UART1_DSR
RI		UART1_RI
DCD		UART1_DCD

Connect UART2 of H350 wireless module (DCE) to PC, and the signal direction of (DTE) is as follows:

MCU (DTE) application	Signal direction	H350 module (DCE)
RXD		UART2_TXD
TXD		UART2_RXD

Note: the high level of the module' s UART interface is 1.8V. If it needs to connect it to 2.8V or 3.3V IO interface, it is necessary to switch the level.

In design: it is recommended to use SN74LVC2G07 to switch the level from 1.8V to 3.3V. During the communication between UART1 and PC, firstly raise the level from 1.8V to 3.3V, and then, employ SP3238 to switch the level. During the communication between UART2 and PC, firstly raise the level from 1.8V to 3.3V, and then, employ SPIEX3232EEA to switch the level. Pay attention to the signal direction when switching the level.

5.5.3 Ring Indication

UART1_RI signal is used to indicate the incoming calls and SMS, and dispatch pulses to the host application.

Working mode	Status
Default status	Low level
Incoming call ring	1s high level, and 1s low level, repeat this.
New SMS	150ms pulse

5.6 USIM Interface

H350 series wireless modules support USIM and high speed SIM cards. For now, they do not support 8-line intelligent USIM.

5.6.1 USIM Pins

Pin#	Pin Name	I/O	Function Description
26	USIM_VCC	O	USIM power supply signal
25	USIM_RST	O	USIM Reset signal
24	USIM_CLK	O	USIM clock signal
23	USIM_IO	I/O	USIM data signal
28	GND	GND	USIM ground signal
27	USIM_CD	I	USIM Plug-in detection signal The internal module has been pulled up. High level indicates that SIM card is not inserted. Low level indicates that card is inserted.

5.6.2 USIM Interface Design

5.6.2.1 “Normal Closed” SIM Card Circuit Design

Reference Circuit Design :

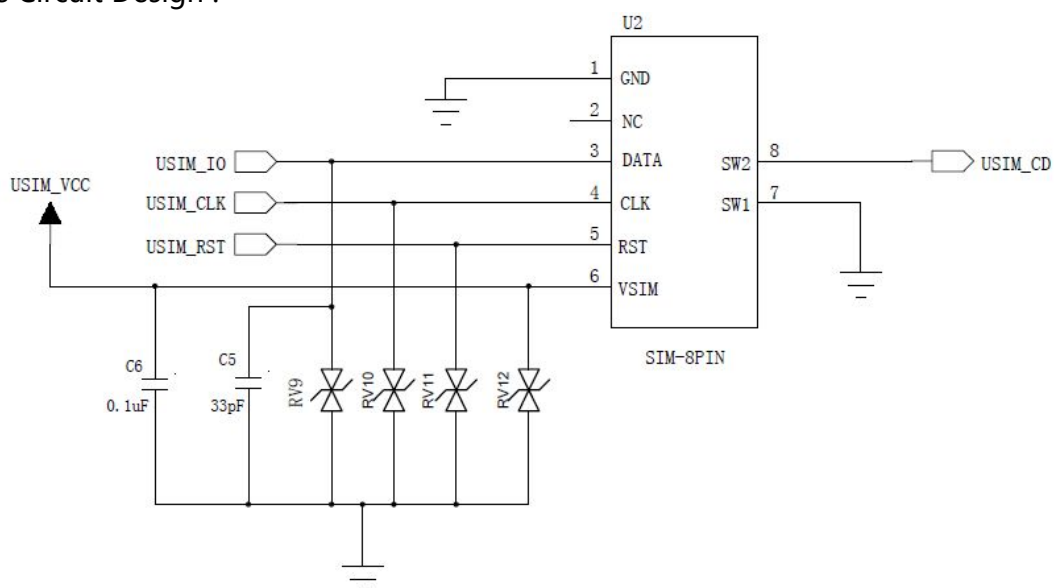

Figure 5-8 Reference Design of “Normally Closed” SIM Card Interface

Normally closed SIM Connector:

- 1) Pull out SIM card, pin 7 and pin 8 will short-circuit .
- 2) Insert SIM card, pin 7 and pin 8 will disconnect.

5.6.2.2 “Normally Open” SIM Circuit Design

Referenced Circuit Design:

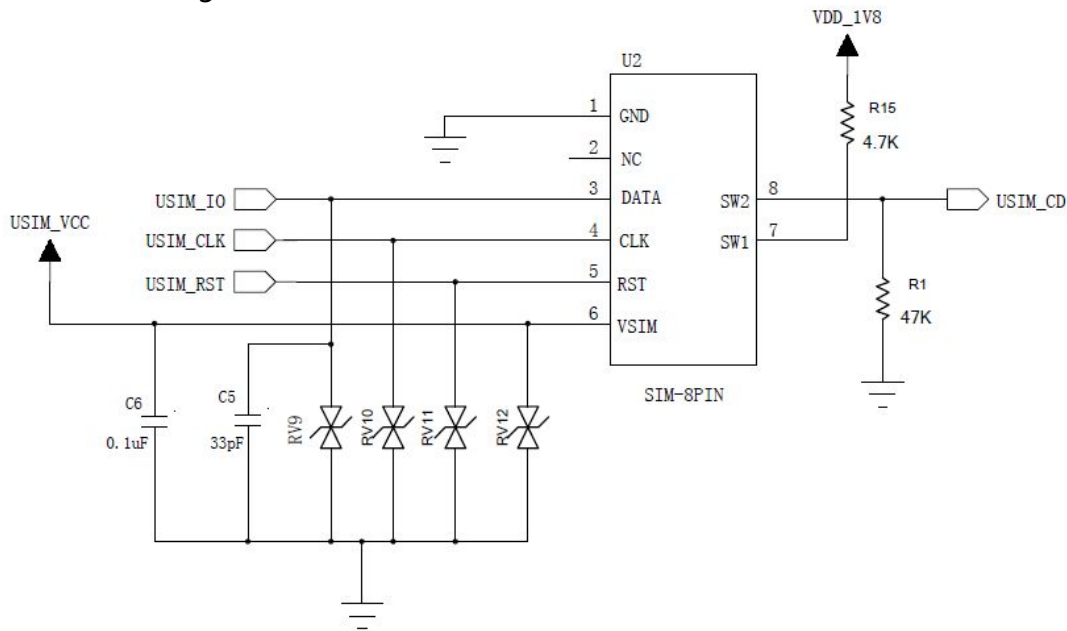

Figure 5-9 Reference Design of “Normally Open” SIM Card Interface

Normally Open SIM Connector:

- 1) Pull out SIM card, pin 7 and pin 8 will disconnect.
- 2) Insert SIM card, pin 7 and pin 8 will short-circuit

Note:

- In order to improve EMC performance, the SIM card slot should be close to the module to the largest extent.
- The filter capacitor on the SIM-card signal circuit should be placed close to SIM card pin to the largest extent.
- ESD device (like TVS) shall be added to the SIM-card signal circuit protection. ESD device should be placed close to SIM card pin.
- USIM_IO has been pulled up inside the module. No need to pull it up again from the outside.
- USIM_CD signal connection supports hot-plugging; active low. If the module detects the signal at low level, it means there is a card in the module.

5.6.3 Points for Attention in USIM Design

SIM card interface design is very important for the normal operation of the module and SIM card. The following points need to be complied with during the design:

- SIM card layout and wiring must keep away from EMI interference source, like RF antenna and digital switch signal.
- In order to ensure signal completeness, the wire distance between the module and SIM card should not exceed 100mm.
- In order to avoid mutual interference, USIM_CLK and USIM_IO signals should be separated in wiring. It would be best to wrap them with ground wire respectively.
- SIM card signal line should be protected with ESD. These protective devices should have small capacitance (like Zener diode, etc.). Users are recommended to select ESD devices with equivalent capacitance lower than 33pF. During layout, ESD device should be close to the SIM card interface.

5.6.4 USIM Hot-Plugging

H350 supports SIM card status-detection function. This function allows the hot-plugging of SIM card.

5.6.4.1 Hardware Connection

SIM card hot-plugging function needs to work with SIM_DETECT signal.

USIM_CD will be at low level without SIM card; after inserting SIM card, USIM_CD will be at high level.

Note :

- For “Normal closed” SIM card, as shown in the figure5-8, USIM_CD signal line is connected to U2’ s Pin8 (SW2), and Pin7 (SW1) is connected to the ground. When the SIM card is not inserted, SW2 and SW1 short circuit, SW2 will be at low level. When the SIM card is inserted, SW2 and SW1 will be disconnected, USIM_CD level will be pulled up.
- For “Normal opened” SIM card, as shown in the figure5-9, USIM_CD signal line is connected to U2’ s Pin8 (SW2), and Pin7 (SW1) will be pulled up 4.7K resistor . When the SIM card is not inserted, SW2 and SW1 will be disconnected, then SW2 will be at low level. When the SIM card is inserted, SW2 and SW1 will short circuit, USIM_CD level will be pulled up.

5.6.4.2 Software Settings

“+MSMPD” configures AT command for the SIM card status-detection function.

- If set AT+MSMPD=0, SIM card status-detection function will be closed, and the module will not detect USIM_CD signal.
- If set AT+MSMPD=1, SIM card status-detection function will be in opened, and the module will detect if the SIM card is inserted by USIM_CD Pin.
- If USIM_CD is at low level, which indicates SIM card is inserted, the module will automatically register it to the network.
- If USIM_CD is at high level, which indicates SIM card is not inserted, the module will not register it to the network.

Note: the default of +MSMPD parameter is “1”. USIM_CD is only the hot-plug detection. The module will not detect the USIM_CD at the first power on (No matter how the level status of SIM_CD, the module will read the SIM card and register network at the first power on).





5.7 Digital Audio

H350M.2 module supports digital audio I2S interface that supports normal I2S mode and PCM mode. I2S interface level is 1.8V on average.



I2S signal description:

Pin#	Pin Name	I/O	Description
18	I2S2_CLK0	O	Bit Clock
14	I2S2_WA0	O	Left and right channel clock (LRCK)
15	I2S2_TX	Os	Serial data output
16	I2S2_RX	I	Serial data input
20	I2C_DATA	I/O	I2C control signal input/output
19	I2C_SCL	O	I2C control clock signal
38	CLKOUT0	O	26MHz main clock output

5.7.1 I2S

H350	Signal Direction	Audio CODEC I2S Port
I2S2_CLK0		I2S_CLK
I2S2_WA0		I2S_LRCK
I2S2_RX		I2S_SDOUT
I2S2_TX		I2S_SDIN
CLKOUT0		I2S_MCLK

5.7.2 I2C

H350	Signal Direction	Audio CODEC I2C Port
I2C_SDA		I2C_SDA
I2C_SCL		I2C_SCL

Description:

- I2S interface can be configured as client-server work mode.
- Suitable for various audio sampling frequencies(48KHz, 44.1KHz, 32KHz, 24KHz, 22.5KHz, 16KHz, 12KHz, 11.025KHz and 8KHz).

5.7.3 PCM Port Description

H350	Signal Direction	Audio CODEC PCM Port
I2S2_CLK0(PCM_CLK , PCM clock signal)		PCM_CLK (PCM clock signal)
I2S2_WA0(PCM_SYNC , PCM frame synchronization signal)		PCM_SYNC (PCM frame synchronization signal)
I2S2_RX(PCM_DIN , PCM data input)		PCM_DOUT (PCM data output)
I2S2_TX(PCM_DOUT , PCM data output)		PCM_DIN (PCM data input)

Note:

- PCM interface can be configured as client-server work mode.
- Support short frame synchronization at 16, 32, 48, and 64 bit mode.
- Support burst and continuous mode transmission.
- Suitable for various audio sampling frequencies(48KHz, 44.1KHz, 32KHz, 24KHz, 22.5KHz, 16KHz, 12KHz, 11.025KHz and 8KHz).

5.8 ADC Interface

H350 supports ADC detection, with precision of 10bit. ADC input voltage is required to be 0~1.2V.

ADC signal description:

Pin#	Pin Name	I/O	Description
41	ADC1	I	ADC input

5.9 Other Interfaces

The module does not support GPIO and MIPI yet.

6 Electrical and Environmental Features

6.1 Electrical Features

The table below lists the range of H350' s electrical characteristics:

Parameters	Minimum Value	Maximum Value	Unit
Power supply signal	0	4.5	V
Digital signal	0	1.9	V

6.2 Environmental Features

This table below shows the environmental features of H350 :

Parameters	Minimum Value	Maximum Value	Unit
Operational Temperature	-30	+75	°C
Storage Temperature	-40	+85	°C

7 RF Interface

7.1 Operating Frequency Band

7.1.1 Frequency Range of Antenna

Operating Band	Tx	Rx
UMTS 2100 (Band I IMT)	1920 - 1980 MHz	2110 - 2170 MHz
UMTS 900 (Band VIII IMT)	880 - 915 MHz	925 - 960 MHz
GSM 900	880 - 915 MHz	925 - 960 MHz
DCS 1800	1710 - 1785 MHz	1805 - 1880 MHz

7.2 RF PCB Design

7.2.1 Wiring Principle

Because H350 has no RF connector, the user needs to connect a length of RF line to the antenna, or design a connector on the board. So, it is recommended to use microstrip line for RF line. It should be as short as possible with loss controlled below 0.2dB, and impedance of 50 ohm.

Reserve a π circuit (the earth terminals of the two parallel devices should be directly connected to the main ground) between H350 module and the antenna connector (or feed point) for antenna tuning.

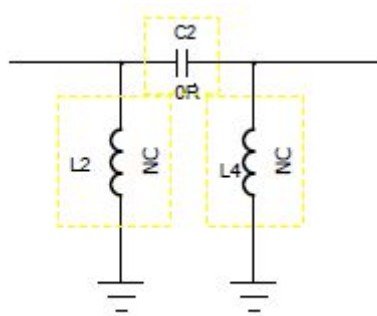

Figure 7- 1π -type Circuit

7.2.2 Impedance Design

The impedance of RF signal line of antenna interface needs to be controlled at 50 ohm.

7.3 Antenna Design

7.3.1 Main Antenna Design Requirements

(1) Antenna efficiency

Antenna efficiency is the ratio of the input power and radiant power. Because of the antenna's return loss, material loss and coupling loss, the radiant power is always lower than the input power. The ratio is recommended to be $> 40\%$ (-4dB).

(2) S11 or VSWR

S11 shows the matching degree of the antenna's 50 ohm impedance, which affects antenna efficiency to a certain extent. It is feasible to use VSWR testing method to measure the index. It is recommended that $S11 < -10\text{dB}$.

(3) Polarization

Polarization is the rotation direction of the electric field of the antenna at the direction of the largest radiation.

It is recommended to use linear polarization; for diversity antenna, it is recommended to use different polarization directions from that of the main antenna.

(4) Radiation pattern

Radiation pattern refers to the electromagnetic field intensity at various directions in the far field of the antenna. Half-wave doublet antenna is the perfect terminal antenna. In the case of built-in antenna, it is recommended to use PIFA.

- Antenna area: H 6mm * W 10mm * L 100mm. It is recommended to use PIFA or IFA.
- Antenna radiation direction: Omni-directional.

(5) Gain and directivity

Antenna directivity refers to the electromagnetic field intensity at various directions of the electromagnetic wave. Gain is the combination of the antenna efficiency and antenna directivity. It is recommended that antenna gain $\leq 2.5\text{dBi}$.

(6) Interference

In addition to antenna performance, other interference from the PCB will also affect the module performance. In order to ensure the high performance of the module, the interference must be

under control. Suggestions: keep speaker, LCD, CPU, FPC wiring, audio circuit, and power supply away from the antenna; add appropriate separation and shielding devices, or conduct filtering on the path.

(7) TRP/TIS

TRP(Total Radiated Power) :

- W900/ W2100 > 19dBm
- GSM900 > 28dBm
- DCS1800 > 25dBm

TIS (Total Isotropic Sensitivity) :

- W900 < -102dBm
- W2100 < -103dBm
- GSM900 < -102dBm
- DCS1800 < -102dBm