



GOODALLDESIGN



C2 Owners Manual

Contents

Contents	1
Introduction	4
<i>About this Owner's Manual.....</i>	<i>4</i>
<i>General Information</i>	<i>5</i>
Assembly	7
<i>Glossary.....</i>	<i>7</i>
<i>Tools needed.....</i>	<i>8</i>
<i>Arrival of goods</i>	<i>8</i>
<i>Platform.....</i>	<i>8</i>
<i>Mast</i>	<i>13</i>
<i>Rigging.....</i>	<i>15</i>
<i>Spinnaker pole.....</i>	<i>15</i>
Rigging.....	16
<i>Raising / Lowering the Mast.....</i>	<i>16</i>
<i>Spinnaker Pole.....</i>	<i>19</i>
<i>Spinnaker System</i>	<i>20</i>
<i>Boom</i>	<i>26</i>
<i>Mast Rotation.....</i>	<i>26</i>
<i>Rudders.....</i>	<i>27</i>
<i>Centerboards</i>	<i>29</i>
<i>Mainsail.....</i>	<i>29</i>
<i>Jib</i>	<i>33</i>
Sailing.....	35
<i>Launching</i>	<i>35</i>
<i>Recovery</i>	<i>35</i>
<i>Towing on the Water.....</i>	<i>37</i>
<i>Tuning.....</i>	<i>38</i>
Maintenance	46
Systems (Diagrams)	47
<i>Cunningham</i>	<i>47</i>
<i>Spinnaker Halyard</i>	<i>48</i>

Warranty 50

The Full Warranty Period..... 50

Warranty conditions..... 50

Exclusions, this Warranty does not cover 50

Operation Limitations..... 51

Limitations..... 51

Responsibilities 51

Voided warranty..... 51

Introduction

Congratulations on purchasing your new GOODALL C2. The C2 is the direct result of 7 years research and development. During that time we developed and learned from the CAPRICORN platform and now we have combined that knowledge with state of the art manufacturing techniques to bring you the highest quality and performance possible.

A handwritten signature in blue ink that reads 'Greg Goodall'.

Greg Goodall

Managing Director

Goodall Design

About this Owner's Manual

This manual has been compiled to help you set up and operate your C2 catamaran safely and easily. It contains details of the boat and its fitted equipment. Please read it carefully and familiarize yourself with it and the boat before rigging and sailing.

You have purchased a high performance racing catamaran and as such you should ensure that you are able to handle the catamaran in the anticipated wind and sea conditions. This owner's manual is not an instructional on boating safety or seamanship. If this is your first beach catamaran, or if your unfamiliar with it, please ensure you obtain handling experience before "assuming command" of the boat. Your Dealer, National Sailing Federation or Yacht Club will be pleased to advise you of local sailing schools, or competent instructors. Buoyancy aids are required for all racing events and are recommended to wear at all times by all crew.

In some countries, a driving license or authorization may be required, or specific regulations might apply. Please familiarize yourself with these.

This craft has been classified (in Australia) as a category C vessel, meaning a boat designed to operate in winds up to Beaufort force 6 scale and associated wave heights.

Always maintain your boat properly and make allowance for the deterioration that will occur in time and as a result of use. Any boat, however strong it may be, can be severely damaged if not used properly. Please read this manual and familiarize yourself with all aspects of maintenance and care for your boat.

Please keep this owner's manual in a safe place and hand it over to the new owner when you sell the boat.

General Information

MANUFACTURER: Goodall Design

MODEL: C2 F18

CATEGORY C: *“A boat designed to operate on winds up to force 6 on the Beaufort scale and associated wave heights (significant waves up to 2 meters) Such conditions may be encountered on exposed inland water, in estuaries and in coastal waters in moderate weather conditions.*

A significant wave height is the mean height of the highest one third of the wave, which approximately corresponds to the wave height estimated by an experienced observer. Some waves will be double this height.”

SPECIFICATIONS:

Length (L_{H1}) = 5.5 m (18 ft)

Width (B_{H1}) = 2.6 m (8.5 ft)

Mast height = 9.1 m (30 ft)

Main sail area = 15.3 m² (183 ft²)

Jib area = 4.15 m² (45 ft²)

Mast area = 1.7 m² (18.3 ft²)

Spinnaker area = 21 m² (226 ft²)

Maximum draft = 1.25 m with centre boards down

Maximum draft = 0.25 m with centre boards and rudders up

Weight fully rigged = 180 kg

IDENTIFICATION: Hull identification number (HIN) is on stern of each hull. Sail numbers are not always indicative of this.

LOADING ADVICE

Keep the total weight of provisions, persons and miscellaneous equipment not supplied by the manufacturer aboard below the Maximum Recommended Load and suitably distributed.

Maximum Recommended Load: ♀ x 2

♀ + ♀ + luggage = 200 kg.

OPENING THE HULL

Hatch covers in the aft deck must be sealed before leaving the shore. When storing the boat ashore, be sure to have the holes covered but leave the hatches open for ventilation purposes.

STABILITY, CAPSIZE AND RECOVERY

This boat is intended to be recovered after capsize by the crew. The minimum crew weight needed is 100 kg. See section **Recovery** for correct recovery technique.

DANGER FROM OVERHEAD POWER LINES AND OTHER OBSTACLES



When rigging and moving your boat, please look up and inspect the overhead area. Observe the location of overhead power lines and trees. These obstacles can damage your boat and are potentially dangerous or deadly to yourselves.



TOWING ON THE WATER

When towing is required, ensure that:

- The tow rope is secured around the mast step or main beam.
- The boat is towed at a low speed.
- The tow line is fastened in such a way that it can be released quickly when under load.
- The tow line is to be of sufficient length to maneuver safely.

Assembly

All GOODALL boats require minimal assembly; all parts are rigged in the factory and come almost fully assembled so that you can be on the water as soon as possible.

Should your boat have come through a local dealer, most of the assembly has probably already been done for you, but take this manual as a reference for building up and dismantling your C2 when transporting and storing.

Glossary

Aft: Back of the boat

Bow: Front of the boat

Batten: Thin rod which fits into a long narrow pocket in the sail

Bridle wire: One of the two wires connected to the bow and forestay

Boom: Spar at the foot of the sail

Centre board (Dagger Board): A retractable plate that slides vertically into each hull

Cleat: Fitting used for holding / securing ropes

Clew: Lower most after-most corner of a sail

Crossbar (Tiller): Bar that connects the rudder arms

Dolphin striker: Load bearing strap under the front beam

Downhaul (Cunningham): Control line to stretch the luff of the sail

Foot: Bottom edge of the sail

Forestay: Front wire supporting the mast

Gunwale: Top outermost edge of the hull

Goose neck: A hinge fitting connecting the boom to the mast

Halyard: Rope or wire used to hoist or lower a sail

Head: The top corner of the sail

Hound: Point where the stays are connected to the mast

Jib: Front sail

Jib Sheet: Control line for jib tension

Leeward: The side of the boat the sails are set to when sailing

Leech: Trailing edge of the sail

Luff: Front edge of the sail

Main sheet: Rope controlling the tension of the main sail

Mast rake: Angle of the mast from vertical

Mast step: Fitting where the mast is connected to the front beam

Gudgeon: Fitting on the transom to attach the rudder

Rudder stock: housing of a rudder blade

Shackle: U-shaped metal strip with a pin to secure halyards etc

Shrouds (Side stay): Wire supporting the mast sideways

Spinnaker: Isometric sail hoisted when sailing downwind

Spinnaker pole: the pole between the hulls used to fly the spinnaker

Spreaders (Diamond): Metal struts placed in pairs to support the mast control the bend in the mast

Stamaster: Adjustable side stay connectors

Stern: Back of the boat

Tack: Forward lower corner of the sail

Tiller (extension): Steering stick connected to the tiller crossbar

Traveler (Car): Runs on the traveler track, which the main sheet is attached

Traveler (Track): Runs side to side on the rear beam

Transom: Flat vertical plane of the end of the hull

Trapeze: Wire to extend the body beyond the gunwale while sailing

Windward: The side of the boat opposite to where the sails are set to when sailing

Tools needed

Your C2 parts will come from the factory pre-rigged so that it can be assembled easily, quickly and without an expensive tool kit, but be advised to have ready with you the following tools:

- Sharp knife
- Cross head screw driver - Philips #2
- 7 mm ring spanner
- 17 mm ring spanner or preferably a hexagonal socket
- 24 mm open spanner
- Torque wrench (optional)
- Shackle tool
- Tape measure
- Duralac sealant (anti corrosive paste)
- Marine grease

Arrival of goods

A typical delivery would consist of 4 packages

- 2 Hull boxes
- 1 Gear box with sails, boom, foils, rudder stocks etc.
- 1 Beam box with main and rear beam
- 1 Mast box with mast and spinnaker pole

Platform

1. Place the 2 cardboard boxes that contain the hulls parallel on a flat surface approximately 2 meters apart and carefully cut the top open. The sides of the boxes may be folded down to provide a clean and protective working surface. The packing frames inside the box should keep the hulls upright while you work.



2. The beams will come from the factory pre-rigged and ready to go onto the boat. The shorter bolts and smaller washers are for the outer locations and the longer bolts and bigger washers for the inner locations. To access the outer bolt holes you will have to remove the plastic end caps from the beams with a Phillips head screwdriver, don't undo any of the shock cords on the front beam as they are already in the correct position.



3. Wipe all dirt and grease from the beam pad before sitting the beam on. Make sure the beams are facing the correct way. The rear beam should have the traveler saddles facing backwards. Apply grease to the threaded part of all bolts before inserting them into the hull. Get all the bolts started before tightening any of the bolts. We recommend beginning with the inner front beam bolt. If a particular bolt is being difficult to fit. Release all the beam bolts and fit this bolt first.



4. Use a 17 mm hexagonal socket or spanner to tighten the bolts properly. The bolts should be set to 20Nm using a torque wrench. Check the bolts regularly but in never exceed the recommended 20 Nm.



5. To reduce the risk of any sharp edges inside the hull tracks cutting the tramp, use a small piece of rod wrapped in sand paper (120 grit or less) and slide the length of the track and back to sand the inside edge of it.



6. To fit the trampoline to the main beam, remove the end plate from the front beam and slide the trampoline into the front beam groove refitting the end plate once the tramp is in place.
7. Loosen all beam bolts 2 turns; fully remove the beam bolts from one end of the front beam and allow the bows to move closer together.
8. Insert the bolt ropes on either side into the track of the hull. Carefully slide the trampoline down the track on each hull. This is best done with 1 person on either side of the platform keeping it even on each side. It is recommended you have someone feed the tramp into the track while another person pulls the tramp on.



9. Refit the beam bolts that were removed in step 7. You will require a 2nd person to push the bows apart to achieve this. Then tighten the remaining bolts to 20 N/m.
10. Slide the alloy tube into the pocket at the rear end. Use the 3mm cord to lace the tramp to the rope buttons on the rear beam as per the picture. By starting at one side, tighten the lacing as much as possible and tie at the other end.



All cords and bungees will be pre-fitted at the factory. Refer to the systems section of this document for diagrams.

11. After the platform has been assembled, the dolphin striker will need to be tensioned. Use a 24mm spanner to extend the striker post between the front beam and the striker strap. The front beam should bow up in the centre (10mm).



- 12.** Toe straps have been provided on the trampoline. Tie the toe straps to the saddles on the rear beam and tighten to preference.



- 13.** Remove the bottom half of the Stamasters from the side stays and attach to the side chain plates with the locknut on the inside and the control line loop facing forward.



- 14.** The Continuous Cunningham system will be setup from the factory, refer to the Systems section for a diagram.
- 15.** Thread the mast rotation (yellow) through the tramp eye and cleat, then around the side stay. Use the spare skippers trapeze shock cord to take up the slack.

Mast

Your mast should already be fully assembled if purchased from a Goodall Design Dealer. If the mast has been shipped directly to you, there is a small amount of assembly required.

- If not already fitted, fit the spreader to their respective brackets and secure the locknuts using a 7mm spanner.



- Pass both diamond wires through the slots in the mast and wind them into the black adjuster nut. Make sure the lock nuts are used.



- Connect thread the adjuster bolt onto the adjuster nut with the mast base in place. Turn about ten turns onto the bolt and push the base into position



- Connect the diamond wires to the top diamond tangs. Make sure the lock pin is in place and cannot fall out

- To fit the diamond wires, the mast should lie flat on the ground. Clip the diamond arm end cap onto the wire and put your feet at one side of the mast at either side of the spreader. Pull the diamond wire until the cap slides into the spreader. Secure it with the screw provided. Repeat this on the other side. You will notice this takes considerably more strength. Make sure the spreaders are perpendicular to the face of the mast and set the diamond tension (in accordance with the tuning guide) with the 17mm bolt at the bottom of the mast base.



- To prevent the spreader being knocked out of alignment during capsize, wrap some high quality tape around the wire and arm. Maintain this as it can decay over time.

If the arms are out of alignment this can cause the arm to collapse and the mast to break.

- Check that the mast is straight in the sideways direction by sighting down the sail track. If the mast has a bend this means that one diamond wire is tighter than the other and they need to be made even. Determine which wire needs to be tightened and releasing it from the diamond arm and the tang towards the top of the mast. Twist the whole wire clock wise while looking from the top of the mast; this will turn the small threaded swage inside the mast base and shorten the wire. Refit the wire to the tang and diamond arm and check for straightness. Repeat if necessary.

Rigging

All rigging is fully assembled at the factory; it will simply need to be attached to the mast. The trapeze wires attach to the upper hole on the hound fitting. The side and forestay attach to the larger lower hole.



Spinnaker pole

Attach the spinnaker chute to the pole with the Velcro straps on the chute.



Now your Boat is ready to rig!!

Rigging

Raising / Lowering the Mast



When rigging and moving your boat, please look up and inspect the overhead area. Observe the location of overhead power lines and trees. These obstacles can damage your boat and are potentially dangerous or deadly to yourselves.



Before raising the mast you should organize your Spinnaker halyard, see **next**.

The usual procedure is to raise the mast from the back of the boat, however the hinged mast step allows the mast to be raised and lowered from any direction. The key to this is that the front of the mast must face the direction that it is to be raised from, or lowered to.

Raising the mast requires a minimum of 2 people. The usual procedure would be:

1. Put the assembled platform on a flat surface, preferably with its sterns windward.
2. Position the mast on the boat, sail track down, with the top of the mast out the stern.



3. Connect the side stays and for stays to the lower hole on the hound fitting ensuring that the forestay is in the center. Connect the Trapeze wires to the upper hole on the hound fitting.



4. Connect the side stays to the corresponding chain plates, with the Stamaster adjusters at maximum length.
5. Untangle and connect the skippers' trapeze wire to the shock cord on the deck. The skippers'

Trapeze will be the outer most on the shackle at the hound.

6. Turn the mast over, sail track up, and connect the base of the mast to the mast step using the hinge pin.



7. Walk the mast up from the stern, you will need to step onto the trap or pass the mast to a 3rd person already on the deck to complete this. At the same time the 2nd person should be pulling the mast up using one of the trapeze wires.



8. When the mast is vertical allow the mast to rotate so that sail groove now faces backwards. **DO NOT** let the mast rotate until it is vertical.

9. Hold the mast upright with one of the trapeze wires while bridle is connected to the chainplate. Connect the bridle to the front chainplates. Ensure the bridled wire with the jib downhaul (Dyneema) is attached to the starboard chainplate (bellow). Wrap tape around the split pins to ensure spinnaker does not catch and tear.



10. Set the fore stay to the appropriate hole on the bridle tube for the required mast rake, as per the tuning guide.
11. Adjust the Stamasters to tighten the rig as per the tuning guide.
12. **Take out the hinge pin from the mast step. This must be removed when sailing to avoid damage.**
13. Connect the crew trapeze wires to their shock cords.

Lowering the mast is basically the reverse as raising it (also requiring 2 people):

1. Detach the boom and spinnaker pole.
2. Put the pin back into the mast step hinge. **IMPORTANT!!!**
3. Loosen the tension on the side stays.
4. Undo at least on trapeze wire.
5. Use that trapeze wire to pull the mast forward, releasing the pin holding the bridle to the chainplate.
6. Turn the mast around so that the front of the mast is facing the aft direction
7. Gently ease the trapeze wire while the 2nd person stands on the trampoline and lowers the mast down. Be careful not to drop the mast on the track of the rear beam.
8. Remove the hinge pin and turn the mast over

9. Undo the remaining trapeze wires and take the Stamasters apart.

Spinnaker Pole

Setting up the spinnaker pole is done after the mast has been raised.

1. Fit the spinnaker pole to the front beam using the pin and retainer clip. The pole must be supported by the bridle loop while this is done.



2. Assure that the knots on both bow braces are the same length. Connect the front braces to the bow by passing a loop through the hole in the bow and then pass the knotted tail through the loop on the outside to prevent the loop coming back through. Work this firm so it will not move during sailing.





3. Adjust the bridle loop so that there is a small amount of pre-bend in the spinnaker pole.
4. Tie the 2mm cord from the ring to port bridle chain plate as this will support the ring while hoisting and dropping and limits spinnaker fouling.



5. Connect the 2 shock cords at the end of the chute to the loops under the trampoline. This should keep the chute taught. These pass UNDER the Cunningham lines.



Spinnaker System

Running the halyards and organizing the spinnaker system is usually done before the mast is raised. Setting up the pole and attaching the spinnaker is done after the mast has been raised.

BEFORE RAISING THE MAST

1. Take the tapered halyard and pass the Dyneema end through the hoisting cleat and up to the hoisting block near the top of the mast passing through any anti foul loops on the way. Make sure the halyard passes in front of all shroud wires and on the port side of the forestay at the hound fitting.

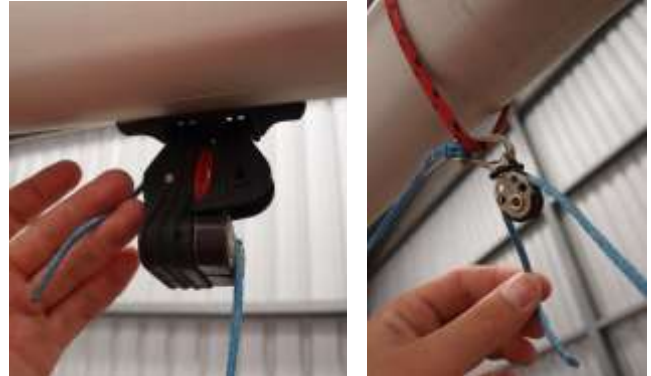

2. Take the Dyneema end and tie it to the mast base for later use, and cleat the other end.

AFTER RAISING THE MAST

HALYARD

1. Pass the retrieval end through the beam saddle, back to the take-up ring on the tramp. Pass it forward through the retrieval block and pass it through the hole in the tramp.



2. Pass the retrieval line through the eyelet in the bottom of the chute and use the tiller extension to pull it up and out by poking the extension down and tying the line to it.



3. Tie the retrieval line to the bridle until you are ready to attach the spinnaker.

4. Before racing you should be sure that the reinforced area of the halyard is in the cleat when the spinnaker is hoisted, adjust this by shortening or lengthening the knot at the head of the spinnaker. The reinforcement on the halyard is near the taper where the halyard feels extra thick.

TACK LINE

The tack line will be already threaded into your spinnaker pole for you. Once the pole is fully attached to the boat the tack line may be threaded as follows:

1. Take the tack line from where it exits the spinnaker pole and pass it around the cheek block on the bottom on the beam. Then, in this order, pass it through the trip line thimble, the cam cleat and the restraining saddle. This should all pass underneath all of the cunning ham lines.



2. Pass the line between the tramp and hull to the turning pulley on the outside of the beam and then pass it through the eyelet in the tramp.



3. On the underside of the tramp, pass the tack line through the ring on the spinnaker retrieval shock cord and finish by tying it off at starboard righting rope saddle on the main beam. These lines should pass on top of all other shock cords.



4. Before racing you should be sure that the reinforced area of the tack line is in the cleat when the tack is fully pulled out, adjust this by shortening or lengthening the knot at the tack of the spinnaker.

ATTACHING THE SPINNAKER

When attaching the spinnaker make sure it is not tangled or twisted. You may hoist, or partly hoist the spinnaker on land to make it easier to organize. This should only be done in sheltered areas or in light winds.

1. Untie the Dyneema end of the halyard from the mast base and tie it to the head of the spinnaker but ensure the runs clearly to the top hoisting pulley.
2. Tie the tack of the spinnaker to the Dyneema end of the tack line (at the front of the spinnaker pole).



3. Untie the retrieval from the bridal and pass it through the retrieval points on the spinnaker and tie it off at the top retrieval point.



4. The spinnaker sheets are attached by hitching the connecting loop in the middle of the spinnaker sheet through the eyelet in the clew of the spinnaker.



5. Take the port spinnaker sheet and pass it inside the crew's trapeze wire and run it through the ratchet on the deck. Then to the turning block attached to the front beam.
6. The other end of the spin sheet passes around the front of the forestay and threaded through the spinnaker blocks the same as the other sheet. The tails of the spinnaker sheet are then tied together.



Boom

Insert the block onto the goose neck and put the pin through the holes, from top to bottom. Secure the pin with the retaining clip.



Mast Rotation

Tie the quick release line from the mast base to the block that comes from the center hole in the tramp.

Rudders

Rudder stocks are uniquely port and starboard. When first attaching rudders they will be stiff, you can lubricate the transom gudgeons with a small amount of grease to assist you in this process.

Place the stocks onto the gudgeon at the transom. Make sure the lock plates snap over the casting and if safety requirements require it, fit the retaining rings on the bottom pins as well.



Connect the crossbar on the pins with the retaining clip.



You should check you rudder alignment before sailing for the first time, see the Tuning section on how to do this.

For the safety of yourself and others please ensure you are familiar with the Lock down mechanism before venturing onto the water.

LOCKING DOWN THE RUDDERS

1. Lift the lock down rod to release it from plastic lockup keeper.
2. Push the rudder to the fully down position.



3. Align the lockdown pin with the hole and squeeze the end of the lock down rod and the tiller arm to press it into position.



4. The lockdown rod should be set to the correct length from the factory. If for any reason you have to adjust it, simply undo the lock nut and rotate the rod to shorten or lengthen it. The rod should be under a medium amount of compression when in the lockdown position, such that there is a small bow in the rod.



RELEASING THE RUDDERS

Lift the middle of the rod to release the pin from the lockdown hole.

Raise the rudder. Press the lock down pin and rod into the plastic lock up keeper.



Centerboards

Both centerboards are the same, but the strap fitted to them makes them port and starboard. The straps should have the retainer knot on the outside of the boat.

The strap connecting the centerboards should pass under the toe straps and all other lines on the tramp deck. When sailing, pulling the strap will raise the board from either side of the boat.

Before putting the centerboards in their casing, rinse the board and the felt lining with water to remove sand and grit that might damage the board. Make sure to keep the centerboards in their protective covers during transportation and storage.

Mainsail

BATTENS

Battens are numbered 1-7, top to bottom.

Roll the main sail out on a flat surface and slide the battens in their corresponding sleeves. Make sure the tapered end fits nicely into the plastic batten pocket ends.

Run the 2 ends of the tie in strings through the hole in the batten, bottom to top and return the ends through the top eyelet. Separate the ends on either side and apply a half hitch around the tie in string.

Push the batten inwards with both thumbs, whilst keeping an end of the tie string in either hand. The half hitch will prevent the batten from coming loose again. When sufficient pressure has been applied, secure the tie in string with a reef knot on top of the half hitch. Feed the remaining ends back into the pocket.

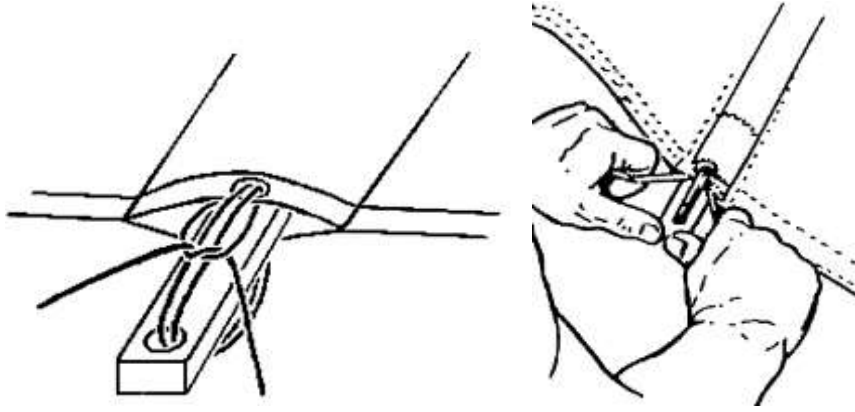

RAISING THE MAINSAIL

Make sure the halyard has a small, tight knot to the ring and shackle. Should you have trouble hooking or releasing your mainsail you should re arrange this knot. Set the boat with its bows to the wind.

Lay the main sail on the trampoline with the luff towards the mast track. Depending on how the main sail has been rolled, it may be required to unroll it completely

Attach the ring and shackle to the eyelet at the head of the main sail and ensure that the halyard is between the ring and mast track. If not the main sail will not engage the hook on the top of the mast.

Just above the boom, the mast track opening is wider to allow the luff of the main sail to enter the track.

Insert the main sail in the groove. Gently pull up the main sail using the halyard.

At the top, the ring will snap over the hook and lock on. Once this has happened pull the main sail down to secure the ring in the notch of the top hook and feed the remaining luff into the mast track.

Stow away the halyard line into the pocket of the trampoline.

Pass the outhaul line through the Clew eyelet of the mainsail and into the cleat.

Fit the bottom block of the main sheet system to the traveler car on the rear beam and secure the shackle.

Using the Dyneema soft shackle connect the clew of the main sail to the boom and top mainsheet block. It should pass around the boom around twice.

Locate the loose end of the main sheet and tie it to the loose end of the traveler line. Make sure the stopper knot on the traveler line prevents the traveler car from hitting the beam bolts at the ends of the traveler track.



Connect the Cunningham to the sail. This consists of 2 single tack pulleys that go either side of the main sail and a single pulley that is attached to a bracket just above the base of the mast. Run the rope loop from one of the clew pulleys through the clew eyelet of the main sail and through the other clew pulley and run the knotted end of the rope through the rope loop.



The clip on the end of the downhaul rope hooks into the hole the mast spanner.

LOWERING THE MAINSAIL

Before lowering the mainsail remove the Cunningham, mainsheet and boom from the sail.

1. Using the halyard, pull the sail up... you should feel it raise about 20mm.
2. While keeping tension on the halyard rotate the mast as far as possible in one direction and pull down on the clew of the sail as hard as you can.
3. Keep the tension on the clew of the sail and slowly release the halyard while allowing the mast to slowly rotate back.
4. The sail should drop out nicely, if not try rotating the mast the other direction.

Jib

JIB SHEET

Firstly the Jib sheet must be set up. The control line part of this will already be setup from the factory.

To finish setting up the jib sheet the Dyneema must be part must be passed through the cheek block on the pole and back through the single pulley on the jib car. Thread the small single pulley (this will be shackled to the jib clew) onto the Dyneema and then tie it back through the center of the jib car pulley.



Pass the jib traveler line (red) through the saddle on the spinnaker pole and then cleat it off in the cleat on the beam.



JIB DOWNHAUL

The jib downhaul runs from the center of the bridal, down the starboard bridal and back to the main beam. To set this up you just need to pass the control line (red), from where in is tied at the main beam, through the pulley attached to the Dyneema and back through the jam cleat on top of the beam.



RAISING THE JIB

Be sure to remove any twists in the downhaul line and halyard. Attach the jib halyard to the top webbing loop of the jib and run both the fore stay and the halyard in to the zip pocket.

Pull the halyard while holding onto the zip runner. Stop when the Dyneema loop on the halyard comes out. Loop the S hook from the jib downhaul to the Dyneema loop.



Pull the zip runner the remainder of the way down and close the webbing with the press stud.

Shackle the tack of the sail to the shackle on the apex of the bridal.

Set the jib luff tension as required.

Shackle the jib sheet single pulley to the clew of the jib. The middle hole will be best for most conditions.



Sailing

Now the boat is fully rigged you are almost ready to set out sailing. Before doing so you should always check over the entire boat and ensure all the shackles, and knots are tight and everything is ready and connected.

Launching

Launching is one of the trickiest parts of sailing, not only do you have to deal with breaking waves and swimmers, you have to do so with minimal rudders and centerboards.

Check over the boat and make sure everything is connected and all knots and shackles are tight prior to launching.

Make sure you are familiar with the rudder mechanism and all other aspects of the boats systems before launching.

Recovery

Despite the fact that a catamaran is essentially a stable platform capsizes happen, even to the best of us. Here are a few tips in minimizing damage when this happens and recovering the boat after it has happened.

As the boat rolls over you will most likely fall towards the rig. If possible avoid landing on the sail or rigging as this can seriously damage it or yourself.

As soon as you hit the water, release yourself and the crew from all lines, including the trapeze wire but **DO NOT** let go of the boat. Hold onto any piece of the boat you can; the capsized boat may drift away faster than you can swim.

Release the Cunningham, mainsheet, traveler, jib sheet and spinnaker sheet. If the spinnaker was in use at the time then it must be pulled into the spinnaker chute before attempting to recover the boat. This can be done from the underside of the boat but care must be taken not to catch the spinnaker as it is being retrieved.

It is essential for righting the boat to point the mast into the wind. If not already the case, let the boat pivot by moving your weight to the tip of the bow.

Take the righting line from under the trampoline and position yourself and crew on the lower hull between the front beam and the centre board casing. Lean out as much as you can. The mast will lift from the water slowly. Be patient, it can take some time, but as soon as the mast is out of the water, the wind will assist you by blowing onto the trampoline. As the boat comes up try to keep your body weight out of the water by pulling yourself up the righting line.



As soon as the boat is upright, grab the dolphin striker. This will, not only keep the boat from capsizing to the other side, but will also keep you and the crew connected to the boat. Climb aboard over the front beam and use the dolphin striker as a step.

Towing on the Water

When towing is required, ensure that:

- The tow rope is secured around the mast base or mast step.
- The boat is towed at a low speed.
- The tow line is fastened in such a way that it can be released when under load.
- The tow line is to be of sufficient length to maneuver safely.

Tuning

*"The philosophy of catamaran sailing is pretty simple... **'It doesn't matter where you are going as long as you are going there fast.'** The element of truth in this statement is that boat speed is ultimately important. Go fast. Look for pressure then angles; opposite priority compared to dinghy."* Greg Goodall on catamaran sailing

To achieve good results in regattas or just sailing fast, it is important to set up the boat for the conditions of the day.

The C2 is a very fast, high performance, racing catamaran with impeccable handling qualities. When you first sail one you are aware that everything happens very quickly. This also includes getting into trouble. As a result it is important that the set up of your boat is clean, simple and efficient. Things that tangle or are difficult to adjust should be eliminated. Almost any system can be made to work in light winds but if it doesn't work in strong winds then you would be better not having it.

PLATFORM

It is important to have your boat as stiff as possible. Make sure that the beam bolts are tight (no more than 20N/m). Keeping the striker strap and tramp tight will ensure the best platform stiffness. Reseating the beam pads will also improve the boat's stiffness, **see next**.

RESEATING BEAM PADS

After years of use the contact between the beam and the beam pad can deteriorate, resulting in reduced platform stiffness. To reseat your pads you will need the following: White gelcoat, masking tape, mould release wax, sandpaper, acetone and a 50mm paintbrush.

Follow these steps (do one beam at a time so that you have enough time before the gelcoat gels):

1. Remove the beam by undoing the beam bolts and pulling the beam out.
2. Briefly sand the beam pad to rough the surface and thoroughly clean beam and beam pad with solvent.
3. Wax the beam anywhere it touches the beam pad or gelcoat might touch it (follow the waxing instructions on the packaging).
4. Mask up the edge and area around the beam pad where you don't want gelcoat to be
5. Mix gelcoat and brush a 2mm thick layer onto the beam pad leaving a 10mm gap around the bolt holes
6. Bolt the beam back into place before gelcoat cures
7. Clean off any excess gelcoat with acetone
8. Repeat on other beam

By waxing the beams you should be able to remove them if you need to, however they will be quite stiff to do so.

RUDDER ALIGNMENT

Correctly aligning the rudders will have a marked effect on the feel and performance of the boat. The simplest method is to support the boat so that the rudders can be put in the fully down position. Use a

tape measure to measure the distance between the leading and trailing edges of the blades at the bottom of the transom. The rudders need to be set up so that they have 2 - 3mm of toe-in; that is the leading edges of the blades are 3mm closer together.



For boats produced **before 2012**: Unscrew the small screw that holds the end into the tiller cross bar and slide the white nylon spacer in or out as desired. DO NOT slide the rubber flex joint out of the nylon spacer. You will need to drill a small pilot hole into the nylon so you can re-screw the small screws back into the ends.

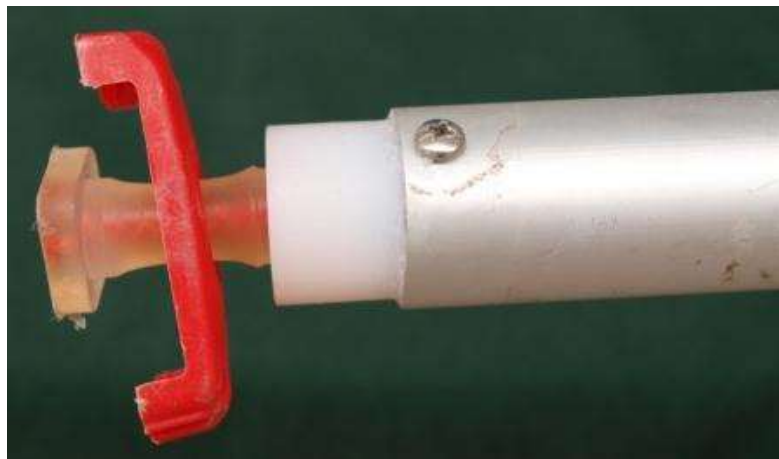

Boats produced **after 2012**: simply wind the adjuster eye in or out as needed. Remember to tighten the lock nut up after adjustment.



NOISY FOILS

Occasionally there will be a foil (rudder or centerboard) that will be very noisy at certain speeds.

Below shows two methods that have proven successful in removing this noise.

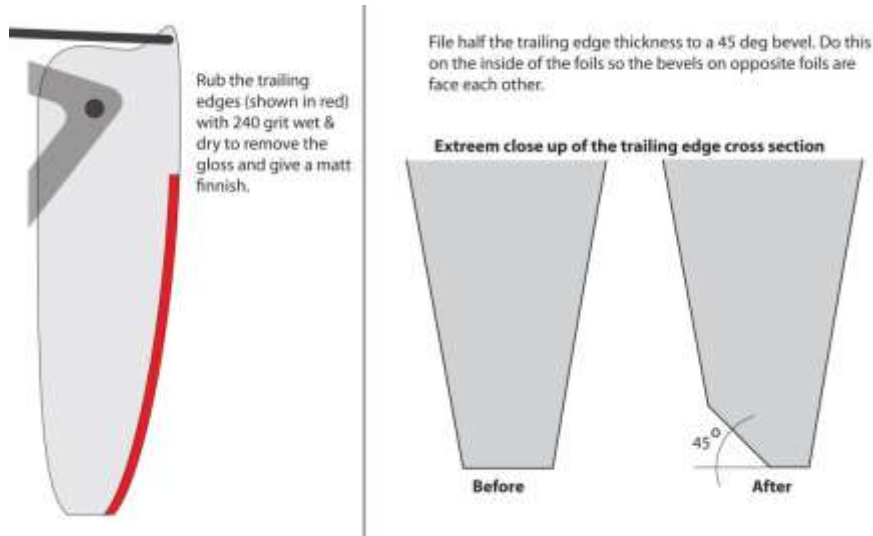

RIG TENSION

The rig tension is in general high to avoid the forestay sagging. If the tension is too high then the mast will not rotate easily. The tension will range from 50kg in light winds up to 100kg in windy conditions.

MAST RAKE

Mast rake affects the trim and balance of the boat. If the boat is sailed with too much mast rake the boat feels a bit heavy on the rudder and it won't accelerate out in the gusts. Insufficient mast rake on the other hand can induce a feeling of lee helm when sailing the boat.

The mast rake is measured with the forward trapeze wire.

Measure the distance to the attachment point of the forestay (bridle) in the hull. This requires the trapeze to be extended with a rope. Mark the rope where it touches the chain plate

Swing the front trapeze to the back of the boat and take the distance measured to the transom.





The standard setting, for 150kg crew weights is the top screw on the plastic rudder clip.

The total range is between the top of the lower pintle and halfway between the two pintles. With lighter crews carrying more and heavier crews carrying less mast rake.

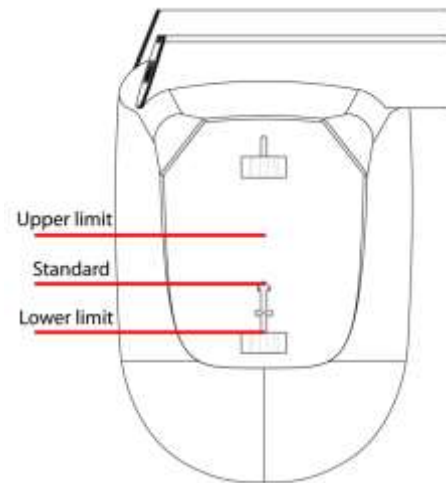

SPREADER RAKE

Spreader rake is a method of tuning the fore-aft stiffness of a mast below the hound fitting. Crew weight affects the required amount of spreader rake as it has a significant effect on the amount power developed by the rig.

To answer how much is sufficient rake can only be determined by sailing the boat and knowing what to look for.

If you have excellent height up wind, but lack boat speed and the boat won't accelerate in the wind gusts, then you need more rake. This helps the mast bend fore and aft which allows the sail to flatten and the leech to open in the wind gusts. (Also see notes on diamond tension.)

If you are lacking height and "grunt" in light to medium weather, then you have too much spreader rake.

The spreader rake is measured by placing a straight edge or string-line between the diamond wires at the spreaders and measure the distance to the back of the mast.

Settings depend heavily on the weight of the crew, with heavier crews generally carrying less rake than lighter crews. The factory setting for 150kg crew weight is 60mm. The range is between (55mm – 65mm)



DIAMOND TENSION

The tension on the diamond wires primarily controls the side bends of your mast. Upwind loose diamonds allow the middle of the mast to bend to leeward and the top of the mast to hook to windward. This tends to cause the boat to heel very easily in wind gusts. Generally speaking, diamond tension is a way of powering or depowering your rig. Wind the tension on to depower and wind them off to power up.

Turning the bolt on the mast base will adjust your diamond tension; this can also be done once the boat is fully rigged.

Diamond tension is run between 35 and 41 on the loose gauge, with the factory setting at 37.



PRE-BEND

Pre-bend of a mast is the result of diamond tension, spreader arms rake and mast stiffness. These days we do not really measure the pre-bend as the same pre-bend can be achieved by varying the amount of spreader arm rake and the diamond wire tension on a given mast.

BATTEN TENSION / WEIGHTS

Battens should be shaped to match the general curvature of the sail. The battens that are recommended and used are the Fibrefoam battens. These battens are a fiberglass foam sandwich construction that is light, strong and have excellent bend characteristics.

Battens should be tied firmly into the sail to remove creases along the batten pocket when sailing.

- Stiff battens hold the sail flat and help to twist the sail more easily, reducing power.
- A soft batten allows the sail to develop more camber and reduces the leach twist, increasing power.

On the table below is the recommended setting per batten.

Batten number (top-bottom)	Batten length	Stiffness - Batten weight	Drive - From front
1	1200 mm	2.5	44 %
2	1325 mm	2.0	44 %
3	1605 mm	1.4	44 %
4	1820 mm	1.2	44 %
5	2000	1.0	44 %
6	2125	1.0	44 %
7	2180	1.0	44 %

GENERAL SETTINGS

The tables below show some general settings currently used. These are guide lines that will make you gain control over the boat more quickly. Be encouraged to try new setting as this will help you learn how all the controls affect the boat. Remember, if in doubt, look around, do what top sailors do and ask why they do this. There is no magic, just experience and understanding the elements and your boat.

BOAT SETUP	Light wind 1-5 knots	Medium wind 6-15 knots	Strong wind 16-25 knots
Diamond Tension	35	35-37	37-41
Mast Rake	One hole forward on forestay	Neutral position	One hole back on forestay
Jib Traveler	100mm from the end of track	50 mm from the end of track	20mm from the end of track
Jib Downhaul	Firm (remove wrinkles)	Tight	Very Tight
Main Outhaul	100 mm from boom	20-30 mm from boom	Minimum

Upwind	Light wind 1-5 knots	Medium wind 6-15 knots	Strong wind 16-25 knots
Crew	No trapeze	Both trapeze	Both trapeze
Hull attitude	Nose down	Level	Nose up
Main traveler	Middle	Middle	Middle
Main sheet	Medium	Hard	Slightly less hard
Main tell tales	Upper flow correctly	Flowing both sides	Flowing both sides
Main Cunningham	Just remove wrinkles	Light - Hard	Extremely hard
Outhaul	100 mm from boom	20-30 mm from boom	Minimum
Mast rotation	Pointing to front of dagger board	Reduce as wind increases	Up to 20 knots 25° Above 20 knots 15°
Jib sheet	Light	Med	Hard
Jib traveler	100mm from the end	50 mm from the end	20mm from end
Jib downhaul	Firm (remove wrinkles)	Firm (remove wrinkles)	Tight
Centerboards	Down	Down	200 - 300mm up

Downwind	Light wind	Medium wind	Strong wind
	1-5 knots	6-15 knots	15-25 knots
Crew	No trapeze	Crew only trapeze	Crew only trapeze
Hull attitude	Nose down	Level	Nose up
Main traveler	Up to 300mm	Middle	Middle 200mm in large waves
Main sheet	light	Medium - Hard	Hard
Main tell tales	Flowing both sides	Flowing both sides	Top windward not flowing
Main Cunningham	Just remove wrinkles	Off	Off
Outhaul	Same as up wind	Same as up wind	Same as up wind
Mast rotation	Pointing to front of dagger board	Pointing to front of dagger board	Pointing to front of dagger board
Jib sheet	Light	Light	Jib fully off but not flapping
Jib downhaul	Same as up wind	Same as up wind	Same as up wind
Centre boards	Down	200 - 300mm up	500mm up

Maintenance

As with all equipment, care of your boat will result in better appearance, longer life and a smoother functioning of all components. Failure to care for your boat properly may void the warranty. Here are some tips to help you care for your boat

- After each use on salt water, rinse off with fresh water paying special attention to blocks and fittings. On fresh water traces of mud or algae can appear, rinsing this off is always a good idea.
- Keep the centerboards and rudders in their covers when not fitted to the boat. Ensure they are dry and clean before storing them.
- The mainsail is best rolled up top to bottom. Release all batten tensions and take the top diagonal batten taken out. Ensure it is dry and clean before storage.
- The jib is best rolled from top to bottom. Ensure it is dry and clean before storage.
- Store the sails in their sail bags, with no heavy items on top, in a dry, dark place without frost.
- When leaving the boat with the mast up, make sure sufficient anchorage is provided to keep the boat aground under heavy winds. Use a line of sufficient strength and padding on the hull. Always use the strong points of the boat to tie it to the anchorage points. They are the beams, dolphin striker and side stay chain plates.
- When leaving the boat with the mast up, fix the mast rotation so that it is NOT free to rotate and flog.
- It is not recommended to store the hull directly on the sand or grass as coloring can occur. It is better to use designated supports to keep the boat from the ground.
- Cover the trampoline for storing out in open air. UV from sunlight will damage the weave of the cloth.
- Check and remove water from the hulls after each trip. Open the inspection hatch, as there are no draining plugs, water must be removed using a sponge.
- When storing the boat ashore, be sure to have the holes covered but leave the hatches open for ventilation purposes.
- Check the blocks for smooth running and if the need arises, spray a little amount of Teflon based lubricant into the wheels. Roll the sheaves by hand to distribute the lubricant.
- Check the rigging for loose strands. Any rigging with a broken strand should be replaced immediately.
- All diamond wires will have a dab of epoxy on the diamond wires both above and below the spreader. TAPE is not suggested as it decays in the weather and easily slips. This prevents the spreader being knocked out of line during capsizes or spinnaker hoist where the halyard wraps

around the spreader and pulls it up. If the arms are out of alignment this can cause the arm to collapse and the mast to break.

- Lock rings, springs, clips and all similar fittings should be taped to prevent them catching and causing damage or injury.

Systems (Diagrams)

Some of the systems on your boat are extremely complex and others are quite simple. Here we have included diagrams of all the systems so that should you need to dismantle it, rebuilding it will be easy.

Cunningham

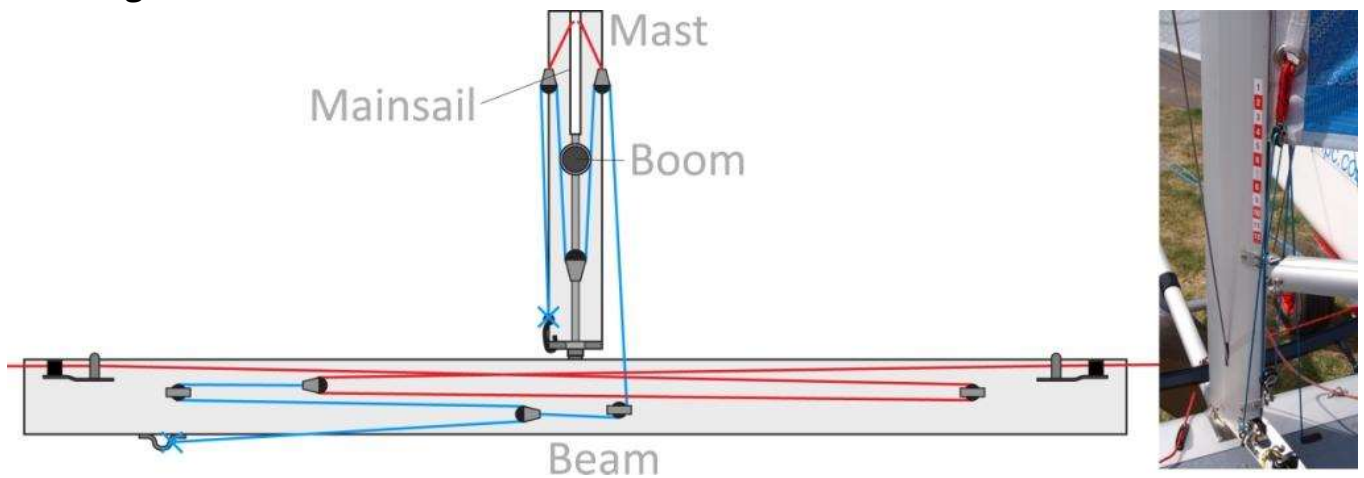

TAKEUP

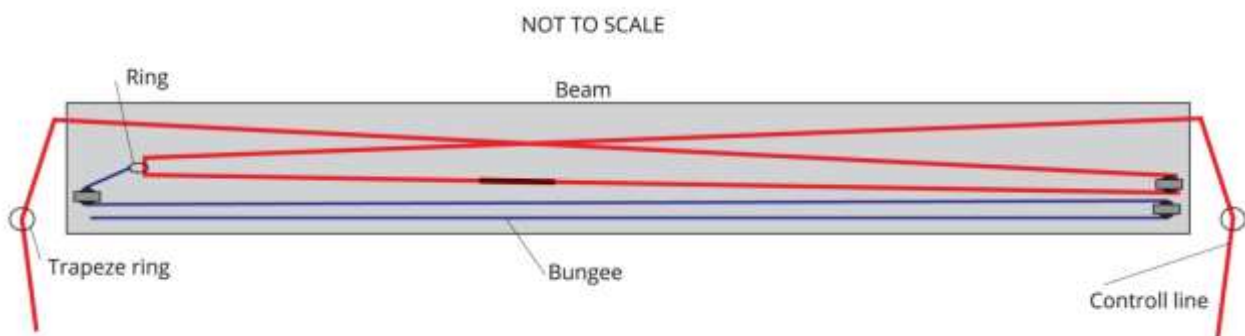

**Spinnaker Halyard
DUEL LINE SYSTEM (WITH TACK LINE)**

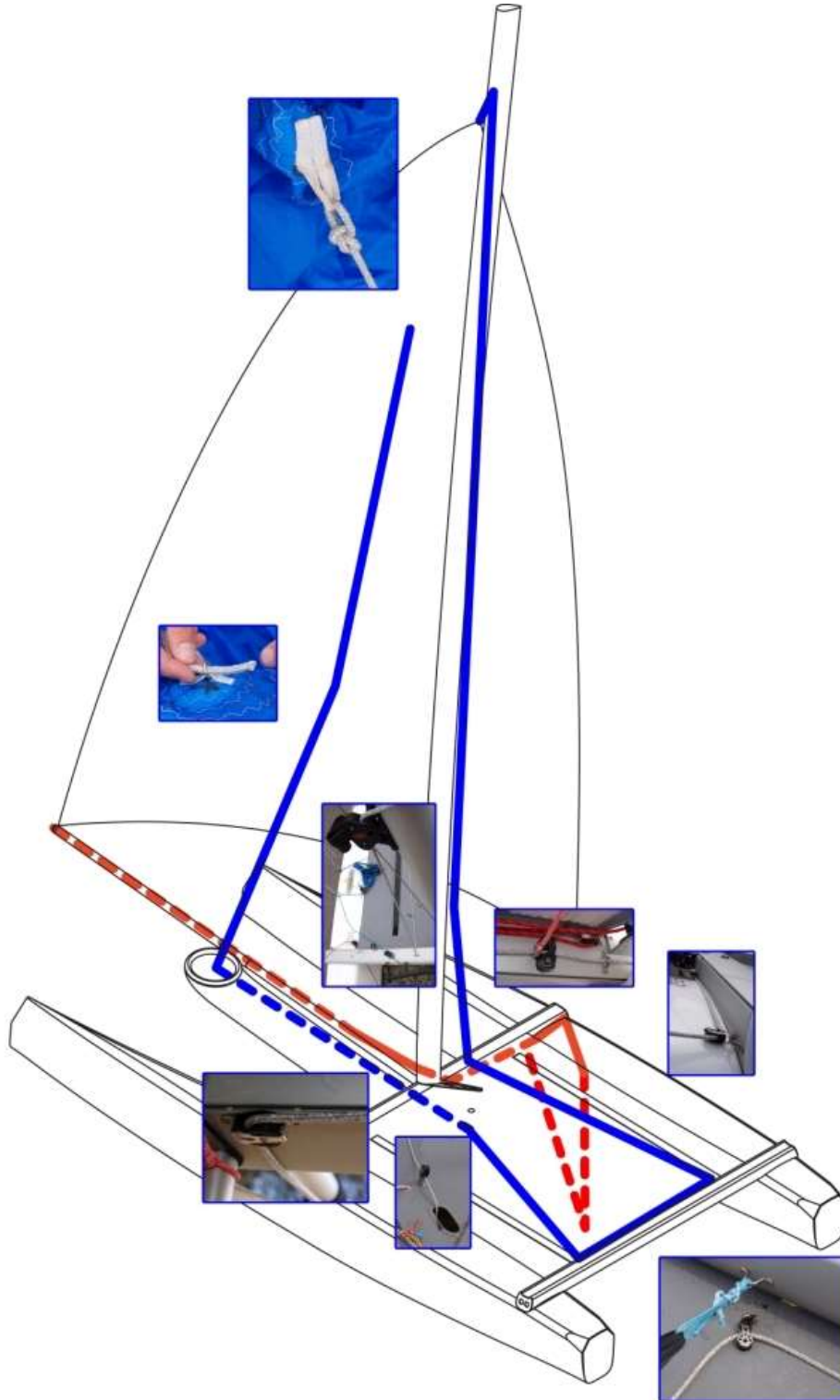

UNDER TRAMP SHOCK CORD LAYOUT

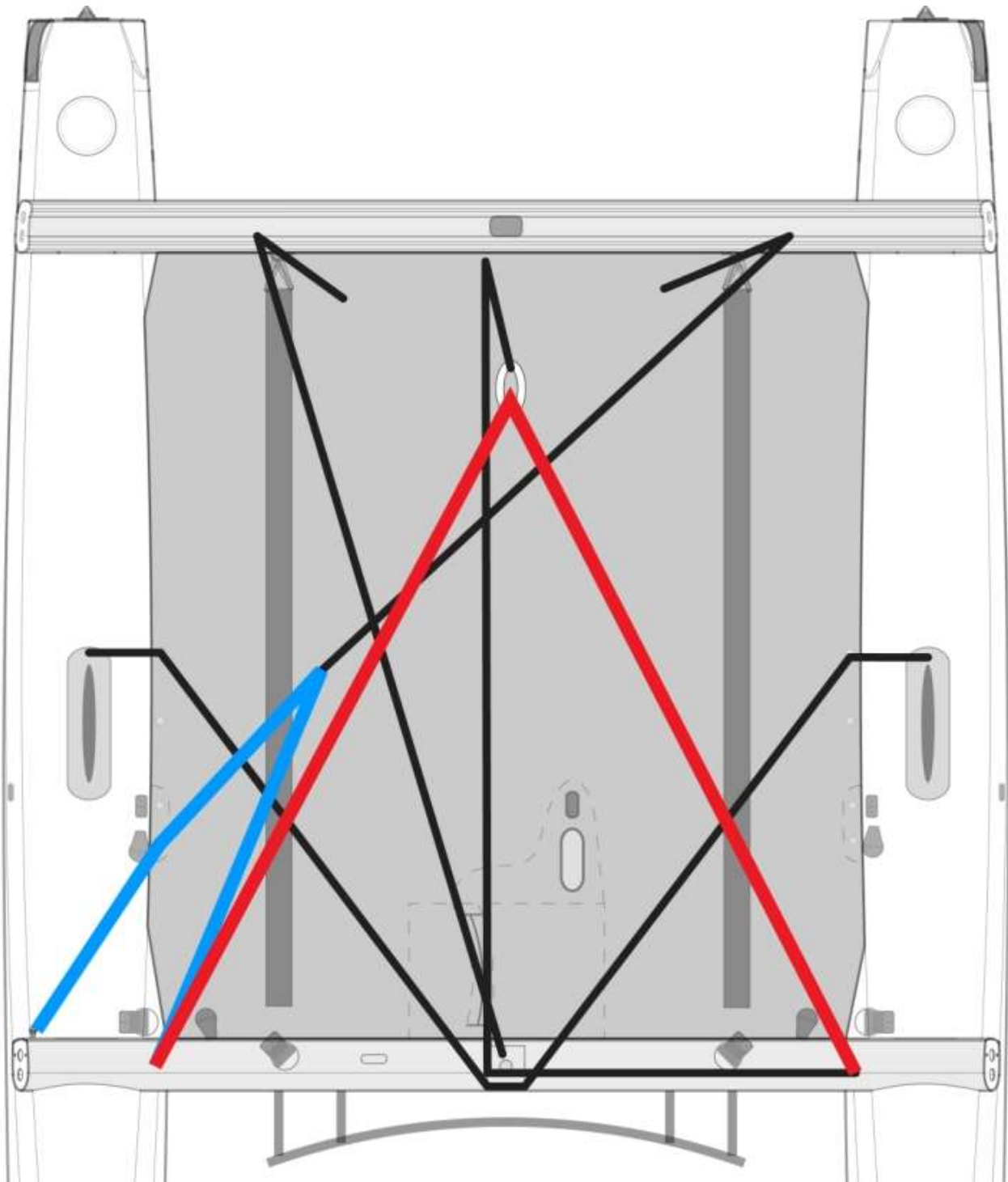

Warranty

The Full Warranty Period

The full warranty period is covering the first 2 years from the customer taking possession of the boat for the first time. During the Full Warranty Period, Goodall Design warrants to the customer that Goodall Design will at its discretion repair, replace or adjust free of charge any part of the boat Goodall Design finds to be defective in factory materials or workmanship when used within the operating limitations of the boat and the provisions of this warranty.

Warranty conditions

This Warranty is limited to the following conditions:

1. The boat is maintained and set up in accordance with the user's manual. Any defects or failure caused by inadequate maintenance or failure to set the boat up as per the user's manual are not covered under this warranty.
2. Secondary and subsequent damage caused by the failure of any component is not covered under this Warranty.
3. The boat must be delivered at the customer's expense to Goodall Design or its nominated representative for the warranted works as soon as possible after the need for the works becomes apparent.
4. This Warranty will not apply to any defect in, or which is attributable to, or which arises from the use of any modification made to the boat unless the modification has been made Goodall Design.
5. This Warranty does not cover damage arising as a consequence of the use of beach rollers, the use of a trailer, high speed beaching, collisions or any type or failing to ventilate the boat.
6. All works under this Warranty must be performed by Goodall Design or its nominated representative at their premises.
7. This Warranty is non-assignable and non transferable.
8. The use of any non Goodall Design equipment shall void Warranty. Equipment includes and not limited to, sails, spars etc.
9. This Warranty is subject to the Exclusions, Operating limitations and Responsibilities.

Exclusions, this Warranty does not cover

1. Damage by heat to composite laminates.
2. Damage by below zero temperatures to composite laminates.
3. "Print" on the hull surface.
4. "Print" from internal frames on the hull skin.
5. Faults or other damage resulting from a collision of any type.
6. Faults or other damage resulting from a capsize of any type.
7. Masts are not covered for failure when sailing under spinnaker.
8. Scratching of any Gelcoat surface.
9. Osmosis of any kind.
10. UV damage to Gelcoat surface.
11. Minor leaks.
12. Wear and tear on all parts. Including, but not limited to, sheets and ropes, rigging, hulls, foils, and spars.

13. Damage to sails due to misuse.
14. Damage to sails due to mast breaking.
15. Secondary and subsequent damage caused by the failure of any component.
16. Boat tuning.

Operation Limitations

This Warranty applies to boats used for recreational sailing or in organized club or championship racing on inland and coastal waters. It does not apply to defects occurring as a consequence of sailing in wind or sea conditions where a reasonable sailing club or association would not sail, or has abandoned racing due to extreme weather conditions. Nor does it apply to offshore sailing and ocean racing.

Crew weight (all persons on board AND luggage) on the boat must not exceed 200 kg

Limitations

The buyer assumes all risk and liability whatsoever resulting from the use of the catamaran and its parts. In no event shall Goodall Design be liable to the buyer for any indirect, special, or consequential damages or lost profits. The provisions of this warranty and limitation of liability may not be modified in any respect, except in writing, signed by a duly authorized officer or representative of Goodall Design. This warranty contains a complete and exclusive statement of Goodall Design's obligations with respect to any of its products.

Responsibilities

This Warranty does not apply unless the owner has kept the boat in good order at all times, performed any necessary preventative maintenance, regularly inspected rigging for signs of fatigue, and taken immediate action to prevent further damage if any fault appears.

Voided warranty

Goodall Design and its representatives may void a warranty for any and all of the above points. Goodall Design and its representatives also reserve the right to publish all sail and hull numbers of vessels that have had the Warranty Voided for any or all of the above points.