

## Non Domestic EPC Conventions for England & Wales Issue 4.0

The conventions in the following pages have been agreed, and approved, by the Non Domestic Energy Performance Certificate (NDEPC) Conventions Group. Membership of the group is open to all Accreditation Schemes as part of the on-going work to standardise the assessment process, and to ensure a uniformity of approach, that will assist Accreditation Schemes and Energy Assessors. The Group has been set up with the approval of DCLG.

These conventions (issue 4.0), which apply to assessments in England and Wales only, have been sent to you by your Accreditation Scheme and must be applied by all NDEPC accredited Energy Assessors. This also applies to those Energy Assessors currently in training. To enable Accreditation Schemes, Energy Assessors and training providers to manage the implementation process successfully please note that not all conventions are applied on the same date. For audit and management purposes, the conventions must be applied on the dates shown in the 'Implementation Date' column on the right-hand side of the table. These conventions will be included as part of future quality assurance checks of the assessments you have undertaken, and the EPCs you have produced, thereafter. New and amended conventions for v4.0 are highlighted by a **light blue background**.

The conventions are designed to improve the quality and accuracy of NDEPC. The conventions will, therefore, supersede any previous assessment process including the iSBEM manual. With this in mind, further conventions are being discussed and developed by the Conventions Group and these will be released to you in stages.

If you have any questions about the conventions, you must feed them back to your Accreditation Scheme (not to DCLG) so the issue you have raised, where appropriate, can be discussed at a future meeting of the Conventions Group. The conventions must be applied as issued, even if you believe there may be a convention that requires further clarification, until such time as the Conventions Group have had the opportunity to discuss the issue you have raised in more detail. Any subsequent change to the conventions will then be circulated to all NDEPC Energy Assessors.

Ref	Issue	Convention	Implementation date
<b>1. Fundamentals</b>			
<b>2. General Information</b>			
2.01	Assessment level	Refer to assessment level decision flowchart and notes – (Issue 1 1 <sup>st</sup> June 2010) amended in issue 2	17 January 2011

## Non Domestic EPC Conventions for England & Wales Issue 4.0

2.02	Use of defaults	The energy assessor shall only use the default values within the Software Tool in the absence of any conventions identified within this document or more specific information on the building. Where a default value is selected the assessor must provide evidence detailing why the default value has been selected to enable their Accreditation Scheme to verify appropriate use of default values during Quality Assurance processes. Use of default values should be avoided where possible.	1 June 2010
2.03	Air permeability	The SBEM default value of $25 \text{ m}^3/\text{hr m}^2$ for all existing buildings shall be amended as follows: Less than $10 \text{ m}^3/\text{hr m}^2$ – only with an accredited air pressure test result $10 \text{ m}^3/\text{hr m}^2$ – buildings > $500 \text{ m}^2$ built to 2002 Building Regulations (or later) $15 \text{ m}^3/\text{hr m}^2$ – buildings $\leq 500 \text{ m}^2$ built to 2002 Building Regulations (or later) and buildings built to 1995 Building Regulations $25 \text{ m}^3/\text{hr m}^2$ – buildings built to Building Regulations pre 1995 $35 \text{ m}^3/\text{hr m}^2$ – to be considered where buildings are pre 1995 regulations and where suitable evidence of high permeability exists, e.g. single skin metal clad structure within Planning Use Class B2 – B8 with large roller shutter doors and poor constructional details etc.	1 June 2010  <b>Amended 30 November 2012</b>
2.04	SBEM Weather Locations	For EPCs in England & Wales select the weather location closest to the subject address using the Excel lookup file – based on the Postcode Area (the initial 1 or 2 letters in the first part of the postcode). For EPCs in Northern Ireland the software should automatically default to 'Belfast'. See ' <b>SBEM Weather Locations 10.05</b> '	1 February 2012
2.05	Planning Use Class	The Energy Assessor is not responsible for establishing the official authorised Planning Use Class of a particular building. However, if Assessors are provided with the authorised Planning Use Class from a suitable source, then this should be entered as the 'Building Type' under the building 'General Details' data entry form. Otherwise, the Building Type will be based on the Assessor's visual assessment of the building on the day of inspection. In both cases, the Assessor is at liberty to alter the Building Type on a zone by zone basis as necessary, in order to model the activity types as seen. The Assessor should as a matter of course, record and be able to provide evidence for the selection of the main building type chosen and any subsequent changes made to the building type at zone level.	1 February 2012
<b>3. Project Database</b>			
3.01	Light pipes	Light pipes ( <i>previously referred to as sun pipes</i> ) and similar devices to be ignored.	1 June 2010

## Non Domestic EPC Conventions for England & Wales Issue 4.0

3.02	Adjacency assumed - party walls	Unless evidence to the contrary is readily and easily available, all buildings adjoining that building or part building which is being assessed, are assumed to be conditioned unless they are of Planning Class B2 to B8 in which case they are assumed to be unconditioned.	1 June 2010
3.03	Frame factor	The 'Frame Factor' within SBEM is set at 10% by default. The assessor should amend this figure where appropriate.	17 January 2011
3.04	Car parks	The following should be used in SBEM v3.5 to define an enclosed or underground car park which has mechanical ventilation and therefore requires either its own EPC or inclusion in an EPC. The activity must be set to "circulation", the HVAC system must be set to "Zones without HVAC system" and the mechanical supply/extract system or the mechanical exhaust system must be used to enter the required "Ventilation" or "exhaust" via the zone level tabs.	17 January 2011
3.07	Appropriate Use of U and Km values	<p>The following must be observed whenever an assessor is introducing their own U and Km values for building elements rather than selecting pre-defined values from the SBEM database</p> <ol style="list-style-type: none"> <li>1. The use of assessor defined values by Level 3 qualified assessors is only appropriate where the values have been calculated by a suitably qualified and accredited person\organisation or have been taken from an 'as built' design specification document. Suitable qualification\accreditation is through membership of a recognised U-value calculation competency scheme (BBA/TIMSA [UK]), OCDEA membership (England &amp; Wales, Northern Ireland) or any other scheme formally agreed between Accreditation Schemes/Approved Organisations and Government.</li> <li>2. Where U or Km values not calculated by the assessor (or introduced from the SBEM database) have been used for the SBEM assessment, a copy of the documentation stating the introduced values must be provided if called for audit with notes describing the validity of the values used. The source of the values will be added to the 'EPC Audit' section of the software used for production of the EPC. If both the U and Km values for a specific building element have been introduced by the assessor, then both values must come from the same source.</li> <li>3. Where the U and Km values used in the EPC assessment have been calculated by the assessor, the values used for the fabric elements pertaining to Thermal Conductivity, Thermal Resistance, Fabric Density and Specific Heat Capacity must be taken from the same source to ensure that the relationships between the values used are appropriate.</li> <li>4. U and Km values, not specific to the building being assessed and introduced from sources other than the SBEM approved database, are not acceptable for an EPC assessment.</li> </ol>	<b>21 January 2013</b>

## Non Domestic EPC Conventions for England & Wales Issue 4.0

3.08	Strongly ventilated spaces	<p>Where ventilation specifications are available, strongly ventilated spaces shall be defined as such in accordance with the table below:</p> <table border="1" data-bbox="539 256 1630 788"> <thead> <tr> <th>Option</th> <th>Brief Description</th> </tr> </thead> <tbody> <tr> <td>Exterior</td> <td>For an envelope separating the considered zone from the outside air or water</td> </tr> <tr> <td>Strongly ventilated spaces</td> <td>For an envelope separating the considered zone from a space provided with one or more permanent openings (i.e., that cannot be closed), with a capacity for the supply of fresh air and extract of inside air, determined according to section 5.3 of NEN 1087, of at least <math>3 \times 10^{-3}</math> m<sup>3</sup>/s per m<sup>2</sup> useable Area.</td> </tr> <tr> <td>Unheated adjoining space</td> <td>For an envelope separating the considered zone from an unheated adjoining space, other than meant under 'Strongly ventilated spaces'.</td> </tr> <tr> <td>Conditioned adjoining space</td> <td>For an envelope separating the considered zone from another conditioned zone.</td> </tr> <tr> <td>Underground</td> <td>For an envelope separating the considered zone from the ground.</td> </tr> <tr> <td>Same space</td> <td>For constructions representing the internal envelopes that separate contiguous zones which have been merged into one zone, i.e., the envelope is "contained" within the merged zone.</td> </tr> </tbody> </table> <p>iSBEM User Guide (February 2012) : Table 9: Options for 'Connects space to' field for envelopes</p> <p>Note that a strongly ventilated space is an alternative to an unheated adjoining space only and is not selected in any other circumstances. Where appropriate ventilation specifications are unavailable, a zone will be considered to be a strongly ventilated space if it is unheated and is one of the following:-</p> <ol style="list-style-type: none"> <li>1. Any part of the building being assessed that is identified with the activity of 'car park'</li> <li>2. Any non-heated/cooled industrial process area that has mechanical extraction/ventilation serving the whole of the zone in order to accommodate the on-going processes.</li> <li>3. Any area that has deliberate fixed openings in order to provide significant natural ventilation, e.g.:             <ol style="list-style-type: none"> <li>a. A plant room with louvered doors / vents for provision of combustion air</li> <li>b. A naturally ventilated internal, underground or basement store area with fixed openings</li> </ol> </li> </ol> <p>Note that windows that are left permanently open are not categorised as fixed openings. If in any doubt, the assessor is to assume the presence of a strongly ventilated space as a worst case default position. Site notes/evidence to be provided accordingly.</p>	Option	Brief Description	Exterior	For an envelope separating the considered zone from the outside air or water	Strongly ventilated spaces	For an envelope separating the considered zone from a space provided with one or more permanent openings (i.e., that cannot be closed), with a capacity for the supply of fresh air and extract of inside air, determined according to section 5.3 of NEN 1087, of at least $3 \times 10^{-3}$ m <sup>3</sup> /s per m <sup>2</sup> useable Area.	Unheated adjoining space	For an envelope separating the considered zone from an unheated adjoining space, other than meant under 'Strongly ventilated spaces'.	Conditioned adjoining space	For an envelope separating the considered zone from another conditioned zone.	Underground	For an envelope separating the considered zone from the ground.	Same space	For constructions representing the internal envelopes that separate contiguous zones which have been merged into one zone, i.e., the envelope is "contained" within the merged zone.	21 January 2013
Option	Brief Description																
Exterior	For an envelope separating the considered zone from the outside air or water																
Strongly ventilated spaces	For an envelope separating the considered zone from a space provided with one or more permanent openings (i.e., that cannot be closed), with a capacity for the supply of fresh air and extract of inside air, determined according to section 5.3 of NEN 1087, of at least $3 \times 10^{-3}$ m <sup>3</sup> /s per m <sup>2</sup> useable Area.																
Unheated adjoining space	For an envelope separating the considered zone from an unheated adjoining space, other than meant under 'Strongly ventilated spaces'.																
Conditioned adjoining space	For an envelope separating the considered zone from another conditioned zone.																
Underground	For an envelope separating the considered zone from the ground.																
Same space	For constructions representing the internal envelopes that separate contiguous zones which have been merged into one zone, i.e., the envelope is "contained" within the merged zone.																

## Non Domestic EPC Conventions for England & Wales Issue 4.0

3.09	Transparent curtain walling	<p>The description of 'curtain walling' in the SBEM database refers to solid or opaque wall construction only and therefore the U and Km values applied to this construction type do not include areas of glazing or translucent materials within the wall space.</p> <p>Areas of glazing or translucent material within a curtain wall should be treated as glazed areas and assessed following the SBEM methodology and iSBEM User Manual. See also '<b>Dimensions Convention 10.03</b>'.</p>	<b>21 January 2013</b>
<b>4. Geometry</b>			
4.01	Light wells	Light wells to be treated as external envelopes.	1 June 2010
4.02	Atria	All atria to be treated as Level 5 NDEPC assessment feature. Refer to accompanying <b>Level 3, Level 4 and Level 5 decision flowchart and notes 10.02</b> .	1 June 2010
4.03	Dimensions	Horizontal and vertical (inc. zone height) measurements to be carried out in accordance with diagrams and notes in 'CEPC Dimension Conventions' documentation.	1 June 2010
4.04	Measurement accuracy (for distance, area and volume)	<p>Calculated values entered into the software for the purpose of an EPC calculation must be provided with supporting calculations presented for audit.</p> <p>The minimum level of accuracy for calculated values entered into the software for the purpose of an EPC calculation is 2 decimal places i.e. 2 places after the decimal point for any given value.</p> <p>All measurements entered into the software must be recorded to at least 2 decimal places on site notes.</p> <p>Where the required level of measurement accuracy is not possible the reason must be recorded.</p>	<b>21 January 2013</b>
4.05	Roofs with multiple components	<p>Where the external roof of a zone or an individual component has a horizontal internal ceiling, the roof shall be entered as having a horizontal orientation and the area of the roof shall be the total horizontal internal surface area exposed to the conditioned space. The roof pitch angle shall be entered as the SBEM default of 45 degrees. See '<b>Roofs with Multiple Components 10.06: Horizontal internal ceiling (Examples 1 and 2)</b>'.</p> <p>Where a horizontal internal ceiling is not present, the roof area shall be that of the internal surface area exposed to the conditioned space and the orientation shall be the compass position that is 'faced' by the pitched component. The pitch angle shall be the angle of the component to the horizontal. See '<b>Roofs with Multiple Components 10.06: No horizontal internal ceiling</b>'.</p> <p>Where a roof structure is constructed of a number of pitched components then each shall be addressed individually and entered as separate components as part of the model, however if individual components have exactly the same set of properties they can be entered as one envelope comprising of the sum area of the components. See '<b>Roofs with Multiple Components 10.06: Roof structure with number of pitched components</b>'.</p>	<b>21 January 2013</b>

## Non Domestic EPC Conventions for England & Wales Issue 4.0

5. Global Building Services			
5.01	Electric power factor	<p>Electric power factor within SBEM must be left at the default value of &lt;0.9 unless you have provided a photograph of the power factor correction device and/or other compelling evidence to amend this figure.</p> <p>Where only a photograph of the power factor correction device is available the power factor shall be amended to '0.9 to 0.95'</p> <p>Compelling evidence includes the following:-</p> <ul style="list-style-type: none"> <li>• Photographic evidence; if the photograph can confirm the actual power factor figure from the device, then select the most appropriate figure within the SBEM power factor drop down options. If the photograph cannot confirm the actual figure but shows evidence of the power factor device, then the assessor shall select the option of '0.90-0.95' within SBEM for the power factor value.</li> <li>• Equipment specifications; name-plates, specification manuals and printouts from Building Mechanical Services (BMS) systems.</li> <li>• Utility bills.</li> <li>• Power factor calculations; conducted by electricians and power engineering specialists.</li> <li>• Meter readings; incorporating reactive unit consumption and appropriate calculations.</li> </ul>	<b>21 January 2013</b>
6. HVAC			
6.01	Variable speed pumps other than central heating	Ignored unless using approved DSM software which allows for this input option.	1 June 2010
6.02	Passive stack ventilation	Treat as per natural ventilation	1 June 2010
6.03	Electric room heaters	Any form of fanned or unfanned electric 'room heater' whether panel, bar, convector or storage heater shall have a user amended efficiency of 1 (i.e. 100%).	1 June 2010

## Non Domestic EPC Conventions for England & Wales Issue 4.0

6.04	LTHW boiler efficiencies	<p>The following hierarchy should be followed to establish suitable values for the 'Effective Heat Generating Seasonal Efficiency' for all boilers.</p> <ol style="list-style-type: none"> <li>1. Use ECA product list part load values at 30% and 100%* - these should be used to calculate the seasonal efficiency as per the Non Domestic Building Services Compliance Guide (NDBSCG).</li> <li>2. Use ECA product list full load value* (when part load values are not given).</li> <li>3. Use current SEDBUK values where available.</li> <li>4. Use either manufacturer's information* or 'boiler plate*' information or information from manufacturer's technical helpdesk*. Where a gross efficiency value is established for a non condensing boiler then a deduction of 0.05 (i.e. 5%) should be made to it to convert it to an appropriate seasonal efficiency.</li> <li>5. Use SAP tables (up to 70kW output).</li> <li>6. Use suitable SBEM default; it is essential for the site notes to provide evidence as to why the above methods were not used to obtain a more accurate value, i.e. by providing evidence of failed attempts.</li> </ol> <p>In addition to any boiler efficiency values established from the above the relevant heating credits should be added by following the guidance in the NDBSCG.</p> <p>*Net efficiencies/values must be converted to gross efficiencies as per the NDBSCG.</p>	17 January 2011
6.05	Electric HWS with and without storage	<p>Where an <b>electric system</b> has <b>no storage</b> then it should be entered as an '<b>instantaneous system</b>' with grid supplied electricity as its fuel and a seasonal efficiency of 1 (i.e. 100%).</p> <p>Where an <b>electric system</b> has <b>some/any storage</b> then '<b>electric instantaneous system</b>' should <b>NOT</b> be used and '<b>Stand-alone water heater</b>' should be used. Where such a system also has its losses or volume and insulation details entered then the efficiency of the system should be 1 (i.e. 100%).</p>	17 January 2011
6.06	HWS efficiencies and storage losses	<p>The presence of storage/losses <b>MUST</b> be entered for all storage systems and this should be done where possible by entering the losses (in MJ/month) in preference to the volume and insulation type and thickness. The source information (such as manufacturer's data) and/or calculation must be included in site notes.</p> <p>Where losses cannot be established then the volume and insulation details should be entered.</p> <p>Where the volume cannot be readily established via external visual inspection and/or paperwork it should be estimated as follows: the external dimensions of the unit will be used as if the storage vessel completely fills the unit with no deduction for insulation thickness.</p> <p>Where the insulation type can not be readily established via survey and/or paperwork it should be assumed to be uninsulated.</p> <p>Where details of the HWS are unavailable or there is no system then the HWS shall be entered as an '<b>instantaneous system</b>' with no storage with a seasonal efficiency of <b>0.5</b> (i.e. 50%). Where the fuel type can be readily determined then the appropriate fuel type must be entered otherwise 'grid electric' should be assumed.</p>	17 January 2011

## Non Domestic EPC Conventions for England & Wales Issue 4.0

6.07	Estimating Local Mechanical Exhaust rates in buildings	Where it is not possible to obtain details of the fan performance from the Fan nameplate or Building Logbook, Operation & Maintenance manual etc. during the Site Survey, an approximation of the of the air flow rate in $l\ s^{-1}\ m^{-2}$ (often written as $l/s/m^2$ in SBEM) can be established by using an appropriate ventilation rate from the attached table (Local Mechanical Exhaust and Ventilation Rates) and converting this to $l\ s^{-1}\ m^{-2}$ , using the zone height (do not adjust the height measurement used to compensate for an internal ceiling). It is not acceptable to use an arbitrary value such as $5\ l\ s^{-1}\ m^{-2}$ or a software applied default for extraction rates where the mechanical extraction rate is unknown.	17 January 2011  <b>Amended 30 November 2012</b>
6.08	Estimating the Specific Fan Power (SFP) in existing buildings	Where the fan power motor can be established from the fan nameplate or Building Logbook, Operation & Maintenance manual etc. during the site survey the established power will be used to calculate the SFP. If the power rating of a fan is known in horsepower then it shall be converted using the approximation of 1 horsepower = 746 Watts. Where the power rating of the fan is not established then the SBEM defaults will have to be used.	17 January 2011
6.09	Reversible Extract Fans	Reversible extract fans are treated in the same way as non-reversible extract fans in SBEM. It is not acceptable to use an arbitrary value or software default for the extraction rate where the actual value is unknown. Refer to ' <b>Estimating Local Mechanical Exhaust rates in existing buildings 6.07</b> ', to calculate the extraction rate, if necessary.	1 February 2012
6.10	Hot Water Storage Vessels	<p><b>Hot Water Storage Vessels</b></p> <p>Where you have a number of hot water storage vessels that have exactly the same fuel type and efficiency of operation, these can be entered into SBEM as one system incorporating the sum total of the storage losses of the individual storage vessels. In these circumstances it is permissible to aggregate vessels of different sizes as long as the storage losses are known for all individual vessels.</p> <p>Storage vessels that are identified by the insulation type cannot be aggregated as the SBEM model derives an assumption for the storage losses based upon insulation type and vessel size in these circumstances.</p> <p>Individual systems that vary by way of recirculation systems or by the use of CHP or solar energy cannot be aggregated and should be entered separately.</p> <p><b>Instantaneous Hot Water Systems</b></p> <p>Multiple instantaneous systems having the same fuel type and assumed efficiency can simply be entered as one system and allocated to all zones as appropriate.</p>	1 February 2012



## Non Domestic EPC Conventions for England & Wales Issue 4.0

7. Lighting			
7.01	Lighting options in SBEM	<p>If a building's original lighting design is available, and there is no discrepancy between that and the observed lighting within the building, the wattage and lux values, from that design, should be entered using the 'Full lighting design carried out' option in SBEM. If complimentary values are not available (i.e. both values from the same lighting design) the lighting design(s) must not be used.</p> <p>If the circuit wattage and lux levels can be accurately recorded by the assessor (see '<b>Use of Lux Level Meters 7.02</b>') the option for 'Full lighting design carried out' should also be used and the appropriate values entered. Wattage and lux values must not be entered separately nor is it acceptable to input assumed wattage or lux values from BSRIA publications or other reference documents or to accept or use software suggested default value.</p> <p>If the circuit wattage and lux values cannot be ascertained by either of the above methods it may be possible to use the 'Lighting chosen but calculation not carried out' option where the lumens per circuit wattage must be entered, calculated in line with building regulations guidance. This may not be possible for all zone activity selections. The evidence of how the values for lamp lumens and circuit wattage must be provided in the site notes.</p> <p>If none of the above options are applicable the 'Lighting parameters not available' option should be chosen and the appropriate lamp type for the zone should be selected. For zones with a mixture of lamp types please see '<b>Mixed lighting in a zone 7.03</b>'</p> <p>If no lamps are present, please see '<b>Missing Lamp Selection 7.05</b>'</p>	17 January 2011
7.02	Use of lux level meters	<p>Lux level readings, taken by an assessor, may only be used for the production of an EPC if the readings have been recorded in line with the Society of Light &amp; Lighting's Code for Lighting 2009. Evidence of achieving a complete blackout of windows and the required calculations to establish the grid size for the measurements taken must be provided.</p>	17 January 2011
7.03	Mixed lighting in a zone in SBEM	<p>Where a zone contains both general lighting and display lighting, and for the selected activity SBEM assumes the presence of display lamps, then the display lighting and the general lighting must be entered as 'display' and 'general' lighting respectively.</p> <p>Where a zone contains both general lighting and display lighting, and for the selected activity SBEM does not assume the presence of display lamps, then the zone must be subdivided to create additional 'display' zones to represent the display lighting. A suitable 'display' activity should be used for the 'display' zones and appropriate lighting entries entered. The remains of the original zone must have the original activity and only the general lighting is entered into the zone(s).</p> <p>Where a zone contains a mixture of lamp types providing general lighting (no display lighting) across the entire zone, such that simply splitting the zone to reflect the lamp's locations is not practicable, then the following method should be followed:</p> <ol style="list-style-type: none"> <li>1. The proportion of the zone's area lit by each lamp type should be established.</li> <li>2. The zone should then be split into a number of zones to match the number of lamp types and for each lamp type the relevant proportion of the zone area and all of the zone's envelopes, including glazing, should be entered into each relevant zone along with the appropriate respective lamp type.</li> </ol>	17 January 2011

## Non Domestic EPC Conventions for England & Wales Issue 4.0

7.04	Display lighting	<p>Where zones incorporate an activity whereby SBEM automatically assumes the presence of display lighting but none is actually present, the display lighting efficiency for SBEM shall be entered such that it is the same as that of the general lighting present in that zone.</p> <p>Where possible this should be calculated but as this requires detailed measurements of the lm and cW this is not usually practical in existing buildings. The following 'default' values should therefore be used:</p> <ol style="list-style-type: none"> <li>1. For all general lamp types except Tungsten or Tungsten Halogen; you must enter that the display lighting uses efficient lamps and enter 50lm/cW in the relevant Lumens per circuit wattage box.</li> <li>2. For Tungsten or Tungsten Halogen general lamps; you <b>do not</b> enter that the display lighting uses efficient lamps and you do not have to enter a value in the Lumens per circuit wattage box.</li> </ol>	17 January 2011
7.05	Missing Lamp Selection	Where a lamp type is to be selected for a zone but no lamp is currently fitted the assessor should select the least efficient lamp type that can be housed in the installed light fitting. If no light fittings are observed or the acceptable lamp type(s) cannot be ascertained the default selection of 'tungsten' lamps must be made.	1 February 2012
<b>8. EPBD Audit Trail</b>			
<b>9. Recommendations</b>			
<b>10. Appendices</b>			
10.01	Commercial EPC Conventions	<p>Glossary of Terms – Issue 1</p> <p>Updated Glossary of Terms – Issue 2</p> <p><a href="#">Updated Glossary of Terms – Issue 4</a></p>	<p>1 June 2010</p> <p>17 January 2011</p> <p><b>30 November 2012</b></p>

## **Glossary of Terms**

### **Air Permeability**

Air permeability is expressed as volume flow per hour ( $\text{m}^3 \text{h}$ ) of air supplied to the space per square metre ( $\text{m}^2$ ) of envelope area for an internal to external pressure difference of 50 Pa i.e.  $25 \text{ m}^3 \text{ hr}^{-1} \text{ m}^{-2}$  at 50Pa.

### **Atrium**

In this context, a non-continuously occupied interior space within a building, often several stories high, bounded on at least one side by occupied spaces set to the conditions determined from the activity database. There may or may not be building elements (such as glazing) surrounding the atrium (although there may need to be something for smoke control in case of fire). The atrium itself is not maintained to the conditions set by the activity database for adjoining spaces. The technical purpose of the atrium can be one or more of the following:-

- Providing a buffer between the thermal conditions in the adjoining spaces and the exterior, to reduce the direct impact of the exterior on those zones. In this case it should not be maintained to conditions as though it is occupied. (If it is conditioned and the features below do not apply, in this context it is not considered to be an atrium.)
- Providing a means for daylight to reach the middle of deep plan spaces that would otherwise not receive it
- Encouraging stack effect or other passive ventilation to draw extract air from the adjoining spaces.

### **Automatic Blind Control**

In this context internal or inter-pane (but not exterior) blinds that are motorised so that the position can be modified to control solar heat gain and/or glare, controlled by automatic sensors. The control regime must also open the blinds as the heat gain and or daylight levels decrease, so that the use of these natural resources can be optimised for each zone. Note that exterior shading devices can be modelled using iSBEM in the definition of each window; however SBEM currently does not model the re-radiation effects of blinds where solar gain has entered the space before it is modulated by the shading device.

### **Demand Controlled Ventilation**

Is defined as supply and/or extract ventilation that is modulated to match the needs of the actual occupation level of each zone, rather than operating at a constant level defined by the activity database. Thus the energy required to adjust the condition of the supply air and that required to move the air can be reduced. The rate of ventilation would typically be controlled by presence detectors,  $\text{CO}_2$  sensors or another device that senses the varying requirement.

### **Fixed Building Services**

Are those which are directly attached or connected to the building and cannot be removed/disconnected without the use of tools. A portable electric heater with a plug allowing it to be removed from the building without the use of tools is not considered a fixed building service. Although the presence of such a system clearly shows there is an expectation of conditioning and an EPC is required.

### **Light Pipes**

A light pipe is a tube/pipe, consisting of internal reflective surfaces, which channels daylight to an internal area.

## Non Domestic EPC Conventions for England & Wales Issue 4.0 6<sup>th</sup> July 2012

### Lightwell

A lightwell is a space surrounded by the walls of a building but that has no roof or glazing above it. It is therefore similar to a courtyard in appearance. The walls that surround the lightwell are exposed to external air.

### Mixed Use building

A building that incorporates both commercial areas and residential spaces.

### Night Ventilation Strategy

Can be defined as the presence of suitable systems, controls and operating strategy such that overnight ventilation (passive and/or mechanical) is used to cool down the exposed building mass and thereby offset daytime cooling demands. If no such operation and subsequent offset is possible through the *automatic* operation of systems and controls then night ventilation strategy is deemed to be not present as part of the building energy asset rating.

### Self-contained dwelling

A unit designed to accommodate a single household. This would imply it has its own kitchen and bathroom.

### Significant Alteration

Alterations that are covered by the Building Regulations.

### Ventilation with Enhanced Thermal Coupling to Structure

This is a further development of the *Night Ventilation strategy* such that significant components of the building structure in addition to its ordinary surfaces are exposed to night ventilation, in order to enhance the building's capability of offsetting daytime cooling demands. An example of this procedure is the *TermoDeck* system where night ventilation is passed through ducts in the solid floors of the building, thereby increasing the 'coolth' contained in the thermal capacity of the building structure available to offset subsequent summertime daytime cooling loads.

### Variable Speed Drive systems

HVAC system designs are increasingly incorporating variable speed drives (VSDs) to provide control, and reduce the energy consumption of, the motors on fans and pumps.

The term Variable-Speed Drive describes the equipment used to control the speed of pumps, fans and compressors. Variable speed drives may be purely mechanical, electromechanical, hydraulic, or electronic. It is generally accepted that variable speed pumping systems offer significant benefits compared to constant flow systems.

For alternating current (AC) electric motors this is achieved by controlling the frequency and/or voltage of the electrical power supplied to the motor. As the motor reduces the operating speed of the fan, pump or compressor the power required to operate the system is greatly reduced.

# Non Domestic EPC Conventions for England & Wales Issue 4.0 6<sup>th</sup> July 2012

10.02	<b>Commercial EPC Delivery - Updated Assessment Level Decision Flow Chart – Issue 4</b>	1 June 2010 17 January 2011	1 February 2012 <b>30 November 2012</b>
-------	---	--------------------------------	--

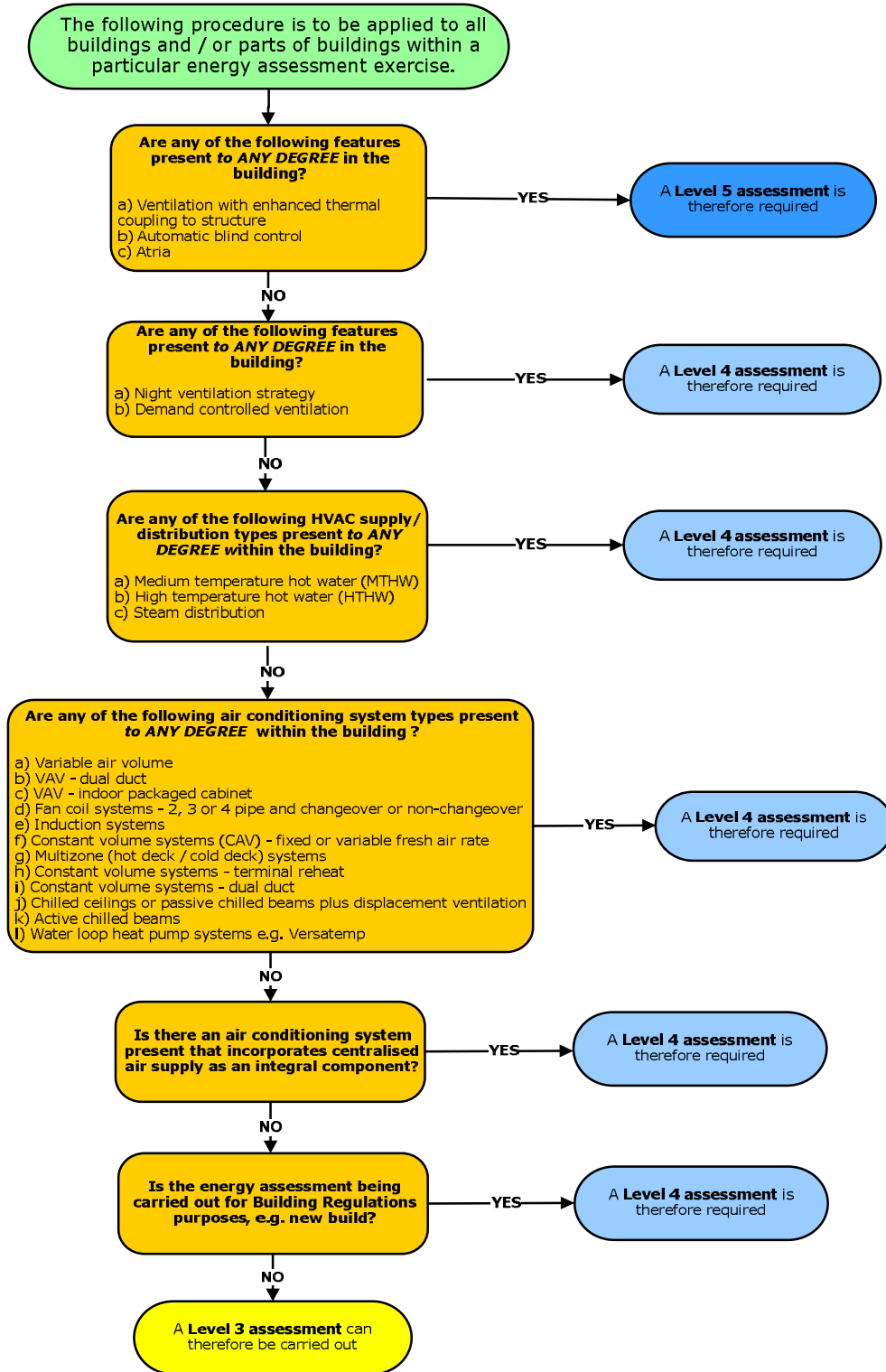

## Non Domestic EPC Conventions for England & Wales Issue 4.0 6<sup>th</sup> July 2012

### Assessment Level Decision Flow Chart: Accompanying Notes

#### ***Night Ventilation Strategy***

Can be defined as the presence of suitable systems, controls and operating strategy such that overnight ventilation (passive and/or mechanical) is used to cool down the exposed building mass and thereby offset daytime cooling demands. If no such operation and subsequent offset is possible through the *automatic* operation of systems and controls then night ventilation strategy is deemed to be not present as part of the building energy asset rating.

#### ***Ventilation with Enhanced Thermal Coupling to Structure***

This is a further development of the *Night Ventilation strategy* such that significant components of the building structure in addition to its ordinary surfaces are exposed to night ventilation, in order to enhance the building's capability of offsetting daytime cooling demands. An example of this procedure is the *TermoDeck* system where night ventilation is passed through ducts in the solid floors of the building, thereby increasing the 'coolth' contained in the thermal capacity of the building structure available to offset subsequent summertime daytime cooling loads.

#### ***Demand Controlled Ventilation***

Is defined as supply and/or extract ventilation that is modulated to match the needs of the actual occupation level of each zone, rather than operating at a constant level defined by the activity database. Thus the energy required to adjust the condition of the supply air and that required to move the air can be reduced. The rate of ventilation would typically be controlled by presence detectors, CO<sub>2</sub> sensors or another device that senses the varying requirement.

#### ***Automatic Blind Control***

In this context internal or inter-pane (but not exterior) blinds that are motorised so that the position can be modified to control solar heat gain and/or glare, controlled by automatic sensors. The control regime must also open the blinds as the heat gain and or daylight levels decrease, so that the use of these natural resources can be optimised for each zone. Note that exterior shading devices can be modelled using iSBEM in the definition of each window; however SBEM currently does not model the re-radiation effects of blinds where solar gain has entered the space before it is modulated by the shading device.

#### ***Atrium***

In this context, a non-continuously occupied interior space within a building, often several stories high, bounded on at least one side by occupied spaces set to the conditions determined from the activity database. There may or may not be building elements (such as glazing) surrounding the atrium (although there may need to be something for smoke control in case of fire). The atrium itself is not maintained to the conditions set by the activity database for adjoining spaces. The technical purpose of the atrium can be one or more of the following :-

- providing a buffer between the thermal conditions in the adjoining spaces and the exterior, to reduce the direct impact of the exterior on those zones. In this case it should not be maintained to conditions as though it is occupied. (If it is conditioned and the features below do not apply, in this context it is not considered to be an atrium.)
- providing a means for daylight to reach the middle of deep plan spaces that would otherwise not receive it
- encouraging stack effect or other passive ventilation to draw extract air from the adjoining spaces.

# Non Domestic EPC Conventions for England & Wales Issue 4.0 6<sup>th</sup> July 2012

10.03 Dimensions Convention

1<sup>st</sup> June 2010

17<sup>th</sup> January 2011

## Dimensions Convention

### Horizontal dimensions

Consider

- Plan view of two buildings in a terrace
  - Separated by a party wall
  - Building 1 has two zones
- Wall types
  - “Perimeter” surrounds each building (external and party walls)
  - “Internal” refers to walls within each building (partitions)

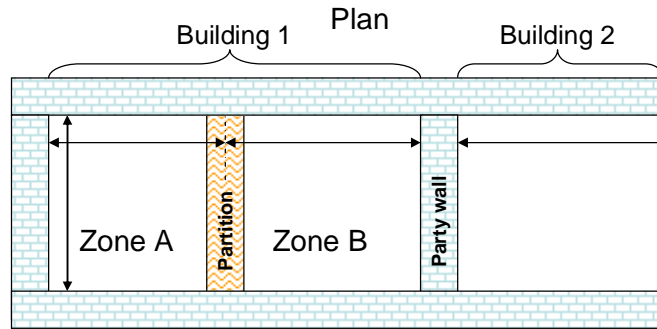

Generally follow RICS definition of Gross Internal Area

Need to measure

- Inside perimeter walls
- Mid point of internal walls
- Party walls are perimeter, so measure to surface, not mid point

### Openings

- Inside structural opening ( $w \times h$ )
- *Not just glass area*
- Percentage glazing is as viewed from inside
  - i.e. percentage of wall area to full zone height (defined below)
- 100% Glazing
  - Enter a wall of total area
  - Enter glazing with same area (or as 100%)

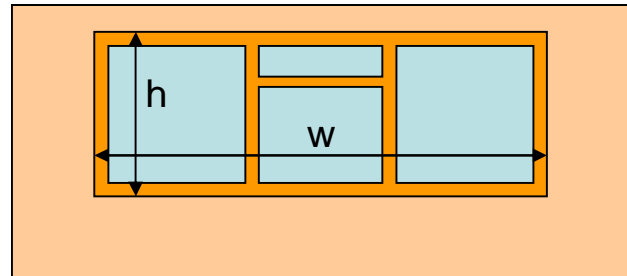

### Zone height and element areas

Generally zone height is top of slab to top of slab for ground and intermediate floors, or soffit/eaves level at roof level

- For ground and intermediate floors
  - Zone height is top of floor to top of floor
- For top floors with flat roof
  - Zone height is top of floor to soffit/underside of roof slab

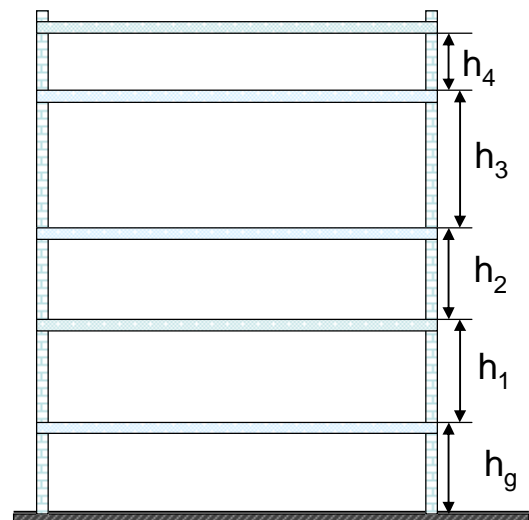

**Non Domestic EPC Conventions for England & Wales Issue 4.0 6<sup>th</sup> July 2012**  
**Dimensions Convention (continued)**

- For top floors with pitched roof but flat ceiling
  - Zone height is top of floor to underside of soffit/eaves level
  - U value is from under ceiling to outside roof including insulation wherever it is
    - that is, consistent with the area being entered
  - Area of gable wall is that below soffit/eaves level i.e. length  $L_4$  x  $h_4$

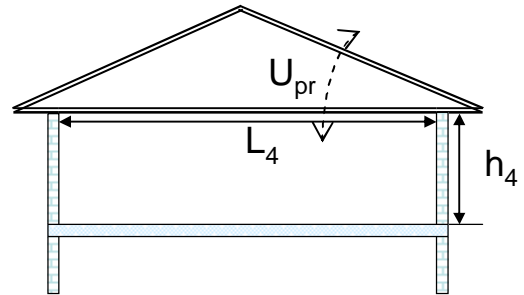

- For top floors with pitched roof and dropped ceiling with or without insulation at ceiling level
  - Zone height ( $h_4$ ) is top of floor to underside of soffit/eaves level (not ceiling)
  - U value is from under ceiling to outside roof
  - Side and end wall areas are calculated to soffit/eaves level i.e. dropped ceiling is treated as though it is at soffit/eaves level

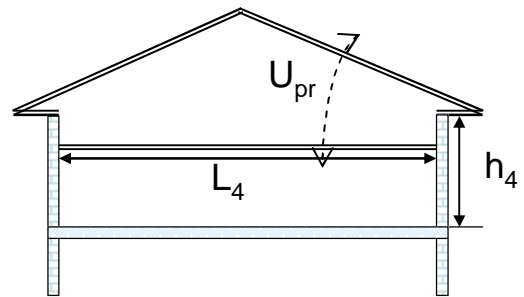

- For rooms with pitched ceiling (e.g. where ceiling is fixed in line of pitched roof)
  - Zone height ( $h_4$ ) is top of floor to underside of soffit/eaves level (*not average room height*)
  - Roof heat loss area is as seen from underside of ceiling, i.e.  $L_r$  x  $d$  (zone depth)
  - U value is from under ceiling to outside roof ( $U_r$ )
  - End wall area is whole gable up to roof apex (as this is all exposed to inside temperature)

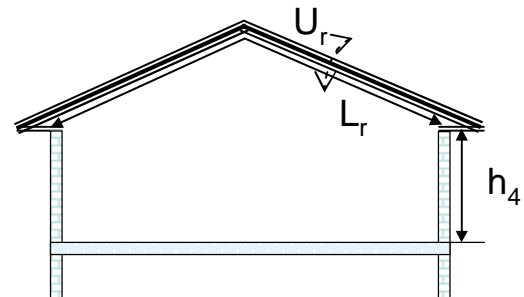

- If there is a horizontal ceiling half way up the pitched roof, split the area into
  - The part with a void ( $L_{r1}$ ), using the U-value including the void ( $U_{r1}$ )
  - The part where there is no void ( $L_{r2}$ ,  $L_{r3}$ ), using the U-value without a void ( $U_{r2}$ )
  - Zone height is still to underside of soffit/eaves level

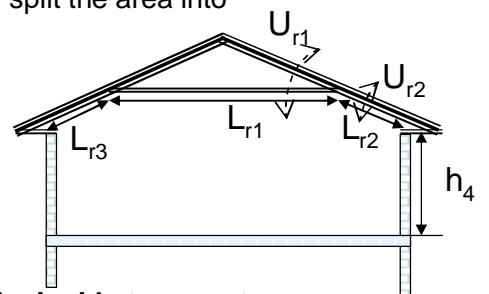

So the general rule is always to **input the area exposed to the inside temperature, and the U-value between this surface and outside.**



## Non Domestic EPC Conventions for England & Wales Issue 4.0 6<sup>th</sup> July 2012

### Dimensions Convention (continued)

- Intermediate floors with suspended ceilings and raised floors

- Zone height is top of floor slab to top of next floor slab e.g.  $h_1$
- So, ignore the suspended ceilings and raised floors for the purposes of
  - zone height
  - surrounding wall areas
- But include their impact on Kappa values of the slabs above and below so that thermal mass effects are calculated correctly

- With suspended timber ground floor and ventilated void below

- Zone height is top of suspended floor surface to top of first floor surface ( $h_{sf}$ )
- Where the floor U value is calculated it should take account of the ventilated void ( $U_{sf}$ )

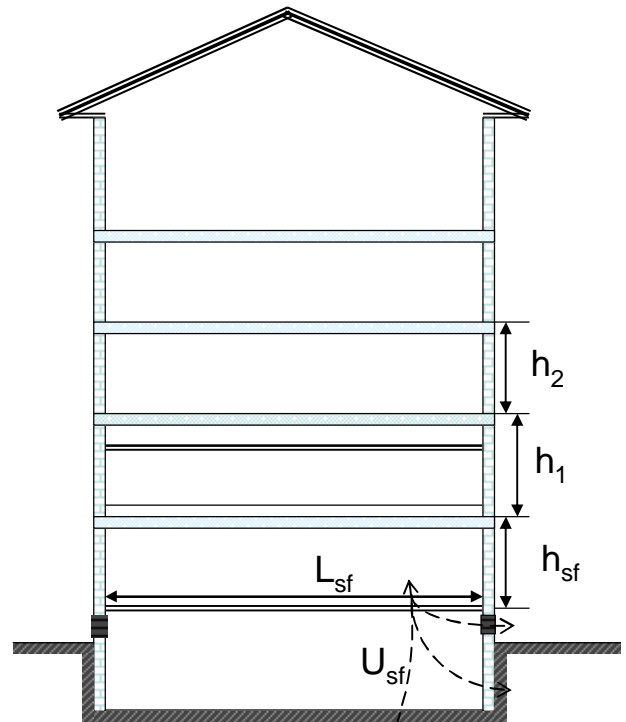

When there are walls of different heights to consider:

- For sloping floors and ceilings (e.g. auditoria)

- If the activity above and under the floor is the same, or the void is inaccessible, choose normal zone height, otherwise
- zone height = weighted average external wall height  $h_{a1}$ ,  $h_{a2}$ ,  $h_{a3}$ , etc (from where floor adjoins each wall to top of floor above)
- Zone area  $A_a$  is projected area/plan area as per RICS GIA standard
- Make sure in addition that all external (and internal) wall and slab areas are input so that all heat loss/gain and thermal mass is calculated
- **Note that zoning for daylight areas must be carried out manually in these circumstances (do not use automatic daylight zoning)**

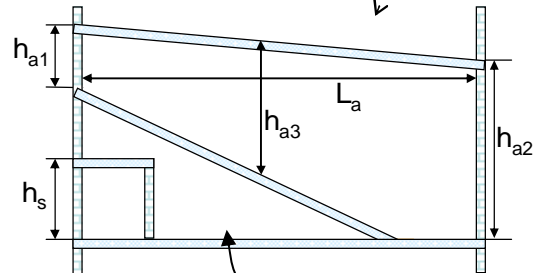

Don't forget this void is another zone if it has a different activity! Its zone height = area weighted average vertical wall height. If it has the same activity or is inaccessible, then merge with auditorium and enter zone area as though the floor is flat ( $L_a \times d$ ). However, the sloping floor area must be input so that thermal mass is calculated.)

- For cubical rooms under the sloping floor
  - Zone height = top of slab to top of slab ( $h_s$ )

## Non Domestic EPC Conventions for England & Wales Issue 4.0 6<sup>th</sup> July 2012

### Dimensions Convention (continued)

- For rooms with mono-pitched ceiling
  - Zone height is top of floor to weighted average height of all external walls -  $h_{4av}$
  - Area of roof ( $A_r$ ) is as seen from underside i.e.  $L_r$  x zone depth
  - U value from under ceiling to outside roof is  $U_r$
  - Use total area of external gable wall
  - Note that zoning for daylight areas must be carried out manually in these circumstances**

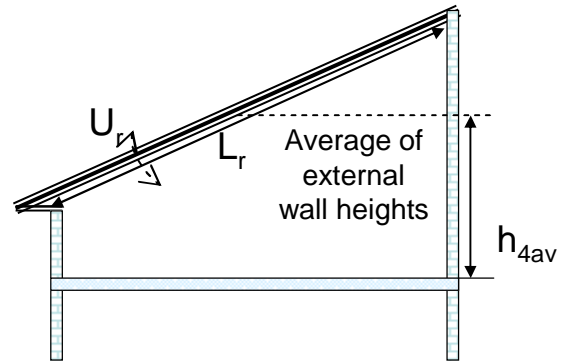

- If there is a horizontal ceiling under the mono-pitched roof
  - Level with or below eaves: zone height at eaves
  - Above eaves: zone height = average exposed wall height
  - Roof area would have to be divided into areas with different U-values with and without void
- Curved roof** – all buildings with curved roof sections shall be approximated as in the diagram:
  - Circular (not elliptical or other shapes)
  - Semi-circular so that width = 2 x height

- Walls are  $70-90^\circ$  from horizontal, roofs are  $<70^\circ$
- So zone height  $h_{cw}$  = dividing point between wall and roof, where slope =  $70^\circ$  at "eaves"

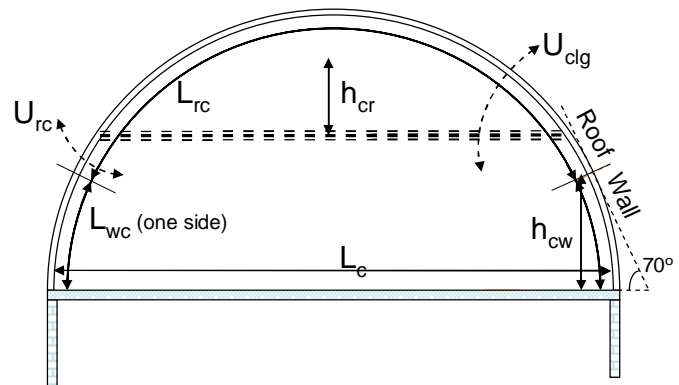

- If a floor (e.g. as shown dotted) meets roof at  $<70^\circ$ , there is no wall, so zone height  $h_{cr}$  = average height of space

- If the dotted line represents the ceiling with an unoccupied void above, remember to input
  - the area of roof where the slope  $<70^\circ$  between this ceiling and the "eaves", with its U value ( $U_{rc}$ ), and
  - the flat ceiling with U value ( $U_{clg}$ ) including the void above the ceiling
- Treat dormer windows the same as for a room in a pitched roof (see below)

For consistency, the convention is to assume all such roofs are semi-circular. If floor width =  $L_c$  and building depth is  $d$

- Zone height  $h_{cw} = 0.171 \times L_c$
- Wall height  $L_{wc} = 0.175 \times L_c$
- Area curved walls =  $L_{wc} \times d \times 2$  (both sides)
- Curved roof width  $L_{rc} = 1.222 \times L_c$
- Area curved roof =  $L_{rc} \times d$

**Non Domestic EPC Conventions for England & Wales Issue 4.0 6<sup>th</sup> July 2012**  
**Dimensions Convention (continued)**

- For room in roof (or mansard roof):
  - Areas and U values should correspond
  - U values for walls should include any voids –  $U_{w1}$ ,  $U_{w2}$
  - Zone height ( $h_{w1}$ ) = height of vertical part of walls adjacent to exterior
  - If this varies, calculate area weighted average height of external walls

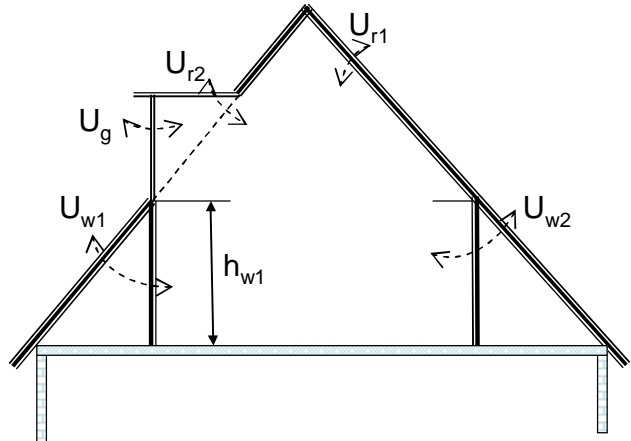

- Where there are dormer windows (i.e. window bays that project through the roof)
  - Do not adjust zone height for the dormer windows
  - Zone manually for daylit areas (if the glazing > 20% of vertical wall area)
  - Enter the glazing details and areas as normal
  - **Note that zoning for daylit areas must be carried out manually in these circumstances**

## Non Domestic EPC Conventions for England & Wales Issue 4.0 6<sup>th</sup> July 2012

10.04 Local Mechanical Exhaust and Ventilation Rates

1<sup>st</sup> June 2010

17<sup>th</sup> January 2011

### Local Mechanical Exhaust and Ventilation Rates

Room or Building	Air Changes per Hour
Assembly Rooms	10
Bakeries	30
Banks/Building Societies	6
Bathroom (non domestic) without Shower	8
Bathroom (non domestic) with Shower	20
Bathroom (domestic)	10
Bedrooms	4
Boiler Rooms	30
Cafés and Coffee Bars	15
Canteens	12
Cellars	10
Cinemas and Theatres	10
Club / Games Rooms	10
Compressor Rooms	20
Conference Rooms	10
Dairies	10
Night Club / Disco	20
Dye Works	30
Electroplating Shops	12
Engine Rooms	30
Entrance Halls, Corridors	5
Factories and Workshops	10
Fitness Centres	12
Foundries	30
Garages (workshop)	10
Glass houses	60
Hairdressing Salons	15
Hotel Bars	10
Kitchens – Non Domestic	40
Kitchens – Domestic	15
Laboratories	15
Launderettes / Laundries	15
Lecture Theatres	10
Libraries	4
Living Rooms	6
Meeting Room	10
Offices	6
Photo and X-ray Darkrooms	8
Public House Bars	15
Recording Studios	12
Restaurants	15
Schoolrooms	10 l/s/Person
Shops and Supermarkets	10
Sports Hall / Squash Courts / Gymnasiums	6
Stores and Warehouses	6
Swimming Pools	10
Tea Making	10
Toilets	10
Utility Rooms	20
Welding Shops (General Extract)	30

# Non Domestic EPC Conventions for England & Wales Issue 4.0 6<sup>th</sup> July 2012

10.05	SBEM Weather Locations	1 <sup>st</sup> February 2012
-------	------------------------	-------------------------------



CL2\_1 SBEM  
Weather Locations Lc



CL2\_1 SBEM  
Weather Locations Lc



CEPC CL2.1 SBEM  
Weather Locations+F

10.06	Roofs With Multiple Components	21 January 2013
-------	--------------------------------	-----------------

**Roofs with Multiple Components**

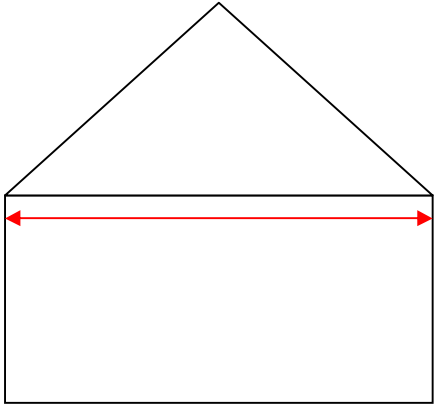

**Horizontal internal ceiling (Example 1)**

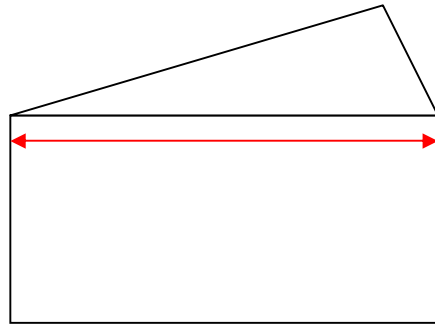

**Horizontal internal ceiling (Example 2)**

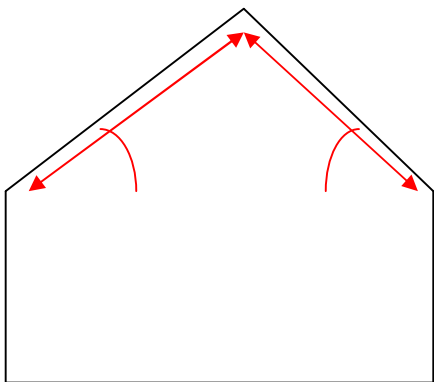

**No horizontal internal ceiling**

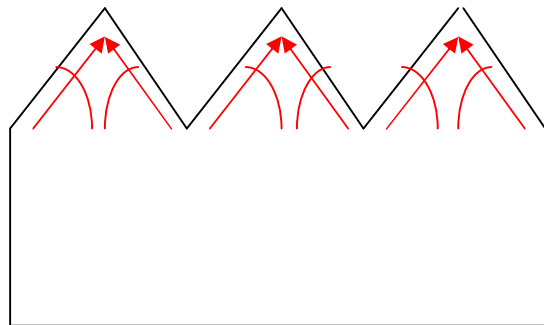

**Roof structure with number of pitched components**