



User's Manual

SteamScrubber® & FlaskScrubber® Glassware Washers

Models

44000 Series 44200 Series
44003 Series 44203 Series
44004 Series 44204 Series

Register your product online at
www.labconco.com/productreg.html
or return the attached card and
receive **FREE LabbyWear™!**



Labconco's Mascot,
Labby the LABster

FREE Video

on washer operation
available on VHS or CD.
See Product Registration
Card to order.



*Protecting your
laboratory environment*

LABCONCO®

LABCONCO CORPORATION
8811 PROSPECT AVENUE
KANSAS CITY, MO 64132-2696
800-821-5525, 816-333-8811
FAX 816-363-0130
E-MAIL labconco@labconco.com
HOME PAGE www.labconco.com

Copyright Information

Copyright © 2002 Labconco Corporation. All rights reserved.

Labconco Corporation
8811 Prospect Avenue
Kansas City, Missouri 64132

The information contained in this manual and the accompanying product are copyrighted and all rights are reserved by Labconco Corporation. Labconco Corporation reserves the right to make periodic design changes without obligation to notify any person or entity of such change.

FlaskScrubber® and SteamScrubber® are registered trademarks of Labconco Corporation.

Warranty

Labconco provides a warranty on all parts and factory workmanship. The warranty includes areas of defective material and workmanship, provided such defect results from normal and proper use of the equipment.

The warranty for all Labconco products will expire one year from date of installation or two years from date of shipment from Labconco, whichever is sooner, except the following:

- Purifier® Delta® Series Biological Safety Cabinets carry a three-year warranty from date of installation or four years from date of shipment from Labconco, whichever is sooner.
- SteamScrubber and FlaskScrubber Glassware Washers carry a two-year warranty from date of installation or three years from date of shipment from Labconco, whichever is sooner.
- Carts carry a lifetime warranty.
- Glassware is not warranted from breakage when dropped or mishandled.

This limited warranty covers parts and labor, but not transportation and insurance charges. In the event of a warranty claim, contact Labconco Corporation or the dealer who sold you the product. If the cause is determined to be a manufacturing fault, the dealer or Labconco Corporation will repair or replace all defective parts to restore the unit to operation. Under no circumstances shall Labconco Corporation be liable for indirect, consequential, or special damages of any kind. This statement may be altered by a specific published amendment. No individual has authorization to alter the provisions of this warranty policy or its amendments. Lamps and filters are not covered by this warranty. Damage due to corrosion or accidental breakage is also not covered.

Limitation of Liability

The disposal and/or emission of substances used in connection with this equipment may be governed by various federal, state, or local regulations. All users of this equipment are required to become familiar with any regulations that apply in the user's area concerning the dumping of waste materials in or upon water, land, or air and to comply with such regulations. Labconco Corporation is held harmless with respect to user's compliance with such regulations.

Contacting Labconco Corporation

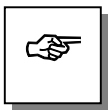

If you have questions that are not addressed in this manual, or if you need technical assistance, contact Labconco's Customer Service Department or Labconco's Product Service Department at 1-800-821-5525 or 1-816-333-8811, between the hours of 7:00 a.m. and 6:00 p.m., Central Standard Time.

Visit Labconco's web site at: <http://www.labconco.com> or email Labconco at: labconco@labconco.com.

TABLE OF CONTENTS

CHAPTER 1: INTRODUCTION	1
About This Manual	2
Typographical Conventions	3
Your Next Step	4
CHAPTER 2: PREREQUISITES	5
Hot Water Requirements	6
Purified Water Requirements	6
Electrical Requirements	7
Drain Requirements	8
Space Requirements	8
Your Next Step	9
CHAPTER 3: GETTING STARTED	11
Unpacking Your Glassware Washer	12
Washer Components	13
Removing the Shipping Skid	15
Setting Up Your Washer	15
Installing the Casters or Leveling Feet	16
Leveling the Washer	18
Centering the Washer Door	20
Attaching the Washer to the Countertop	20
Connecting the Water Supplies	21
Connecting the Hot Water	21
Connecting the Purified Water Supply	23
Installing Faucet Adapters	26
Attaching the Hose-End Coupling	27
Connecting the Drain Hose	27
Connecting the Power Supply	30
Testing Your Washer	32
Connecting the Hose-End Coupling	33
Running the Diagnostics	33
Disconnecting the Hose-End Coupling	35
Your Next Step	36

CHAPTER 4: USING YOUR WASHER	37
Arranging the Washer Racks	37
The SteamScrubber Racks	38
Lowering the Top Washer Arm and Top Rack	38
The FlaskScrubber Rack	41
Loading Glassware into the FlaskScrubber	42
The Detergent Dispenser	44
Filling the Neutralizing Acid Dispenser	46
Selecting an Operating Cycle	47
Programming and Starting a Wash Cycle	47
Interrupting a Wash Cycle	49
CHAPTER 5: MAINTAINING YOUR WASHER	51
Maintaining the Stainless Steel Interior	51
Maintaining the Air Gap	53
Maintaining the Water Fill Valve	53
Maintaining the Overflow Dome	54
Replacing the Washer Light Bulb	56
Removing the Washer Top, Back, and Side Panels	57
Cleaning the Sump Filter Screen	58
CHAPTER 6: MODIFYING YOUR WASHER	59
Disconnecting the Purified Water Pump	59
FlaskScrubber Options	60
Installing Pipet Inserts in a FlaskScrubber	61
Installing the Adjustable-Height Upper Rack	63
Installing the Upper Spindle Rack	66
Installing Inserts into the Spindle Rack	68
CHAPTER 7: TROUBLESHOOTING	71
APPENDIX A: FLASKSCRUBBER AND STEAMSCRUBBER COMPONENTS	76
APPENDIX B: GLASSWARE WASHER DIMENSIONS	80
APPENDIX C: GLASSWARE WASHER SPECIFICATIONS	88
APPENDIX D: GLASSWARE WASHER ACCESSORIES	94
FlaskScrubber Accessories	94
SteamScrubber Accessories	98
Expendables	102
DECLARATION OF CONFORMITY	103

CHAPTER 1

INTRODUCTION

Congratulations on your purchase of a Labconco Glassware Washer. Labconco manufactures two types of Glassware Washers, the SteamScrubber[®] and the FlaskScrubber[®]. Each of these washers is available in a Mobile, Undercounter, and Freestanding model. Each washer model is available in 115V or 230V, and with or without a window in the door.

Your Labconco Glassware Washer is designed and manufactured to thoroughly clean your laboratory glassware and accessories. Using the soft-touch control panel, you can select pre-programmed wash cycles or program customized wash cycles to facilitate your individual requirements.

The Glassware Washer Liquid Crystal Display (LCD) identifies the cycle selected and details about the cycle. Models with a window and light in the door allow you to visually monitor the operation of your washer. Option switches for steaming and using purified water for the final rinses allow you to choose the best conditions for cleaning your glassware.

About This Manual

This manual is designed to help you learn how to install, use, and maintain your Glassware Washer. Instructions for performing routine maintenance and making minor modifications to your washer are also included.

Chapter 1: Introduction provides a brief overview of the Glassware Washer, explains the organization of the manual, and defines the typographical conventions used in the manual.

Chapter 2: Prerequisites explains what you need to do to prepare your site before you install your Glassware Washer. Hot water, purified water, electrical, and drainage requirements are discussed.

Chapter 3: Getting Started contains the information you need to properly unpack, inspect, install, and test your Glassware Washer.

Chapter 4: Using Your Washer discusses the basic operation of your washer. Information on how to arrange the racks inside your washer, properly position the glassware, fill the detergent dispenser, and select an operating cycle is included.

Chapter 5: Maintaining Your Washer explains how to perform routine maintenance on your Glassware Washer. Information on how to safely clean the interior of your washer, maintain the water fill valve, clean the overflow dome, and replace the light bulb is included.

Chapter 6: Modifying Your Washer describes how to disconnect the purified water pump, how to install pipet inserts in a FlaskScrubber, and how to install an optional top rack in a FlaskScrubber.

Chapter 7: Troubleshooting contains a table of problems you may encounter while using your Glassware Washer, including the probable causes of the problems, and suggested corrective actions.

Appendix A: FlaskScrubber and SteamScrubber Components contains labeled diagrams of all of the components of the Glassware Washers.

Appendix B: Glassware Washer Dimensions contains comprehensive diagrams showing all of the dimensions for the Freestanding, Mobile, and Undercounter models of the Glassware Washers.

Appendix C: Glassware Washer Specifications contains the program times and water consumption requirements for the Glassware Washers. Wiring diagrams for both the 115V and 230V washers are also included.

Appendix D: Glassware Washer Accessories lists the part numbers and descriptions of all of the accessories available for your Glassware Washer.

Typographical Conventions

Recognizing the following typographical conventions will help you understand and use this manual:

- Book, chapter, and section titles are shown in italic type (e.g., *Chapter 3: Getting Started*).
- Steps required to perform a task are presented in a numbered format.
- Comments located in the margins provide suggestions, reminders, and references.
- Critical information is presented in boldface type in paragraphs that are preceded by the exclamation icon. Failure to comply with the information following an exclamation icon may result in injury to the user or permanent damage to your Glassware Washer.



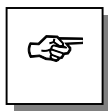

- Important information is presented in capitalized type in paragraphs that are preceded by the pointer icon. It is imperative that the information contained in these paragraphs be thoroughly read and understood by the user.
- Information that is specific to a particular model of Glassware Washer is preceded by a letter icon. The F icon indicates the text is specific to the Freestanding washer model. The M icon indicates the text is specific to the Mobile washer model. The U icon indicates the text is specific to the Undercounter washer model.

Your Next Step

If your Glassware Washer needs to be installed, proceed to *Chapter 2: Prerequisites* to ensure your installation site meets all of the requirements. Then, go to *Chapter 3: Getting Started* for instructions on how to install your Glassware Washer and make all of the necessary connections.

For information on the operational characteristics of your Glassware Washer, go to *Chapter 4: Using Your Washer*.

If your Glassware Washer is installed and you need to perform routine maintenance on the washer, proceed to *Chapter 5: Maintaining Your Washer*.

For information on making modifications to the configuration of your washer, go to *Chapter 6: Modifying Your Washer*.

Refer to *Chapter 7: Troubleshooting* if you are experiencing problems with your Glassware Washer.

CHAPTER 2

PREREQUISITES

Before you install your Glassware Washer, you need to prepare your site for installation. Carefully examine the location where you intend to install your Glassware Washer. You must be certain that the area is level and of solid construction. In addition, a hot water source, a drain, a purified water source (if applicable), and an electrical source must be located near the installation site.

Carefully read this chapter to learn:

- the hot water source requirements for your installation site.
- the purified water source requirements for your installation site.
- the electrical supply requirements for your installation site.
- the drainage requirements for your installation site.

Refer to *Appendix C: Glassware Washer Specifications* for complete Glassware Washer electrical and environmental conditions, specifications and requirements.

Hot Water Requirements

An existing hot water supply may be used as the hot water source for your Glassware Washer. However, the washer requires the inlet water temperature to be greater than 120°F (49°C) to fully activate powdered detergents and raise the glassware temperatures to achieve fast and complete drying. Hotter water will produce better washing results. The maximum temperature of the inlet water should be no more than 150°F (66°C).

Water pressure must be between 20-120 psi (138-827 kPa) at the washer and provide a minimum of 1.25 gallons (4.7 liters) per minute flow rate.

A shut-off valve should be installed in the water supply line plumbed to the washer. The hot water inlet valve on the Glassware Washer is equipped with a female 3/8 NPT fitting.

Purified Water Requirements

Pressurization is not required for the purified water source.

If you intend to use purified water for the final rinse cycles, a purified water supply is required. The washer can be connected to an in-house, pressurized, purified water tap; a water purification system; or a purified water container.

The purified water system must be provided with supply piping of sufficient size to permit at least 1.25 gallons (4.7 liters) per minute of flow (3/8" internal diameter (ID) minimum tube is recommended). The purified water inlet valve on your washer is equipped with a plastic hose barb connection to accommodate 3/8" (9.5 mm) ID flexible plastic or rubber hose. Use a spring or band hose clamp to secure the hose to the hose barb connection. The hose barb connection may be removed from the valve to expose

a male 3/4" - 11-1/2 NH hose coupling. A rigid plastic, tin-lined, or stainless steel tubing and fitting can be connected to the washer fitting.



All connections on the purified water system must be airtight so that the washer pump is not allowed to pull air instead of water.

If the purified water is stored in a carboy, at least 5.8 gallons (22 liters) must be available for each wash cycle. If all 5.8 gallons are not available at the start of a wash cycle, but instead are produced concurrently with the wash cycle, the production rate must permit at least 1.25 gallons (4.7 liters) per minute to be delivered to the washer. In addition, all 5.8 gallons (22 liters) must be made available over a 5-minute period.

Electrical Requirements

If your Glassware Washer is an Undercounter or Freestanding model, it should be hard-wired directly into a junction box using conduit. A 20 Amp circuit breaker or fuse is required for models rated at 115V (60 Hz) or 230V (50/60 Hz).



If your Glassware Washer is a Mobile model, a dedicated electrical outlet is required. A 20 Amp circuit breaker or fuse is required for models rated at 115V (60 Hz) or 230V (50/60 Hz). 115V models are equipped with a 20 Amp NEMA 5-20P plug. 230V models are equipped with a 15 Amp NEMA 6-15P plug. It may be necessary to remove the plug and install a different plug to match the available receptacle.



Drain Requirements

U

F

The Glassware Washer drain hose connects to a fitting on the rear side of the pump/motor assembly. The drain hose is installed at the factory prior to shipment. The hose provides a flexible coupling to the building drain piping and can be secured with a spring or band hose clamp. (A band hose clamp is provided with the washer.)

U

F

Tubing or pipe, ½" (1.3 cm) ID or larger, should be provided for the building drain. The use of an air gap is strongly recommended to prevent siphoning of wastewater into the washer.

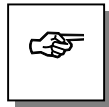

DO NOT REDUCE THE SIZE OF THE DRAIN PLUMBING.

M

Mobile models drain into a sink through a hose assembly that attaches to the faucet.

Space Requirements

U

If your Glassware Washer is an Undercounter model, you must ensure the undercounter opening is the proper size to accommodate the washer. The dimensions for the Undercounter washer are shown below in Figure 2-2.

Figure 2-2

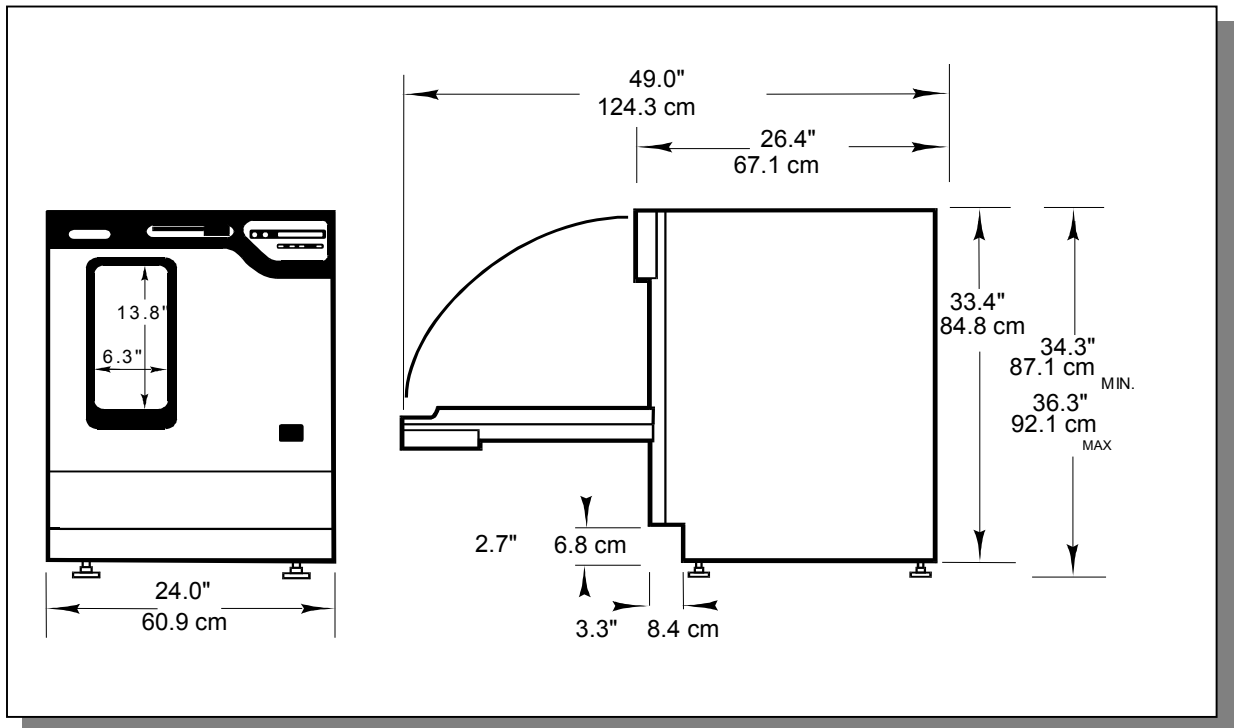

Your Next Step

After you have determined that the location for your Glassware Washer accommodates the installation and operational requirements of your washer, you are ready to unpack and install your washer. Proceed to *Chapter 3: Getting Started*.

CHAPTER 3

GETTING STARTED

Now that the site for your Glassware Washer is properly prepared, you are ready to unpack, inspect, install, and test your washer. Read this chapter to learn how to:

- unpack and move your washer.
- set up your washer.
- connect the hot water and purified water sources for your washer.
- connect the electrical supply source to your washer.
- properly drain your washer.
- perform set-up diagnostics on your washer.

Depending upon which model of washer you are installing, you may need common plumbing and electrical installation tools in addition to a 9/16" wrench, a flat-blade screwdriver, a phillips screwdriver, and a carpenter level to complete the instructions in this chapter.



The Glassware Washer weighs over 70 lbs. (33 Kg). The carton allows for lifting with a mechanical lift truck or hand truck. If you must lift the washer manually, use at least two (2) persons and follow safe-lifting guidelines.

Unpacking Your Glassware Washer

The United States Interstate Commerce Commission rules require that claims be filed with the delivery carrier within fifteen (15) days of delivery.

Carefully unpack your Glassware Washer and inspect the washer for damage that may have occurred in transit. If your washer is damaged, notify the delivery carrier immediately and retain the entire shipment intact for inspection by the carrier.

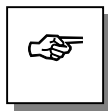

DO NOT RETURN GOODS WITHOUT THE PRIOR AUTHORIZATION OF LABCONCO. UNAUTHORIZED RETURNS WILL NOT BE ACCEPTED.

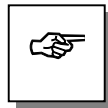

IF YOUR WASHER WAS DAMAGED IN TRANSIT, YOU MUST FILE A CLAIM DIRECTLY WITH THE FREIGHT CARRIER. LABCONCO CORPORATION AND ITS DEALERS ARE NOT RESPONSIBLE FOR SHIPPING DAMAGES.

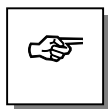

BE CERTAIN TO REMOVE ALL PACKAGING MATERIALS, DETERGENT SAMPLES AND ANY MATERIALS THAT ARE NOT AN INTEGRAL COMPONENT OF THE GLASSWARE WASHER FROM THE INSIDE OF THE WASHER PRIOR TO INSTALLING THE WASHER.

Do not discard the carton or packing material for your washer until you have checked all of the components and installed and tested the washer.

Do not remove the washer from its shipping skid until it is ready to be placed into its final location. Move the washer by placing a flat, low dolly under the shipping skid.

Washer Components

As previously mentioned, Labconco manufactures two types of Glassware Washers, the SteamScrubber and the FlaskScrubber. Each of these washers is available in a Mobile, Undercounter, and Freestanding model. Each washer model is available in 115V or 230V, and with or without a window.

The different washer models require different assembly components. Locate the model of washer you received in the following group of tables. Verify that the components listed are present and undamaged.

Catalog #	Washer Description	
44000-00	SteamScrubber Mobile – 115 V	SteamScrubber Mobile Models
44000-01	SteamScrubber Mobile – 230 V	
44000-10	SteamScrubber Mobile – 115 V with window	
44000-11	SteamScrubber Mobile – 230 V with window	

Plus the Following:

Part #	Component Description
44882-01	Four (4) Casters
45036-00	User Manual
44222-00	Six (6) ounces of LabSolutions Powder Detergent (with MSDS)
45221-00	Eight (8) ounces of LabSolutions Liquid Detergent (with MSDS)
45223-00	Four (4) ounces of LabSolutions Neutralizing Acid Rinse (with MSDS)
44056-00	One (1) Aerator Adapter
44057-00	One (1) Adapter Fitting

Catalog #	Washer Description	
44003-00	SteamScrubber Undercounter – 115 V	SteamScrubber Undercounter Models
44003-01	SteamScrubber Undercounter – 230 V	
44003-10	SteamScrubber Undercounter – 115 V with window	
44003-11	SteamScrubber Undercounter – 230 V with window	

Plus the Following:

Part #	Component Description
18798-01	Four (4) Leveling Feet
45036-00	User Manual
44629-00	Two (2) Screws
14888-00	One (1) Clamp
44222-00	Six (6) ounces of LabSolutions Powder Detergent (with MSDS)
45221-00	Eight (8) ounces of LabSolutions Liquid Detergent (with MSDS)
45223-00	Four (4) ounces of LabSolutions Neutralizing Acid Rinse (with MSDS)
14201-20	Elbow (1)

SteamScrubber Freestanding Models	Catalog #	Washer Description
	44004-00	SteamScrubber Freestanding – 115 V
	44004-01	SteamScrubber Freestanding – 230 V
	44004-10	SteamScrubber Freestanding – 115 V with window
	44004-11	SteamScrubber Freestanding – 230 V with window
	Plus the Following:	
	Part #	Component Description
	18798-01	Four (4) Leveling Feet
	45036-00	User Manual
	44680-00	One (1) Hole Plug
14888-00	One (1) Clamp	
44222-00	Six (6) ounces of LabSolutions Powder Detergent (with MSDS)	
45221-00	Eight (8) ounces of LabSolutions Liquid Detergent (with MSDS)	
45223-00	Four (4) ounces of LabSolutions Neutralizing Acid Rinse (with MSDS)	
14201-02	Elbow (1)	
FlaskScrubber Mobile Models	Catalog #	Washer Description
	44200-00	FlaskScrubber Mobile – 115 V
	44200-01	FlaskScrubber Mobile – 230 V
	44200-10	FlaskScrubber Mobile – 115 V with window
	44200-11	FlaskScrubber Mobile – 230 V with window
	Plus the Following:	
	Part #	Component Description
44882-01	Four (4) Casters	
45036-00	User Manual	
44222-00	Six (6) ounces of LabSolutions Powder Detergent (with MSDS)	
45221-00	Eight (8) ounces of LabSolutions Liquid Detergent (with MSDS)	
45223-00	Four (4) ounces of LabSolutions Neutralizing Acid Rinse (with MSDS)	
44056-00	One (1) Aerator Adapter	
44057-00	One (1) Adapter Fitting	
FlaskScrubber Undercounter Models	Catalog #	Washer Description
	44203-00	FlaskScrubber Undercounter – 115 V
	44203-01	FlaskScrubber Undercounter – 230 V
	44203-10	FlaskScrubber Undercounter – 115 V with window
	44203-11	FlaskScrubber Undercounter – 230 V with window
	Plus the Following:	
	Part #	Component Description
18798-01	Four (4) Leveling Feet	
45036-00	User Manual	
44629-00	Two (2) Screws	
14888-00	One (1) Clamp	
44222-00	Six (6) ounces of LabSolutions Powder Detergent (with MSDS)	
45221-00	Eight (8) ounces of LabSolutions Liquid Detergent (with MSDS)	
45223-00	Four (4) ounces of LabSolutions Neutralizing Acid Rinse (with MSDS)	
14201-02	Elbow (1)	

Catalog #	Washer Description	FlaskScrubber Freestanding Models
44204-00	FlaskScrubber Freestanding – 115 V	
44204-01	FlaskScrubber Freestanding – 230 V	
44204-10	FlaskScrubber Freestanding – 115 V with window	
44204-11	FlaskScrubber Freestanding – 230 V with window	

Plus the Following:

Part #	Component Description
18798-01	Four (4) Leveling Feet
45036-00	User Manual
44680-00	One (1) Hole Plug
14888-00	One (1) Clamp
44222-00	Six (6) ounces of LabSolutions Powder Detergent (with MSDS)
45221-00	Eight (8) ounces of LabSolutions Liquid Detergent (with MSDS)
45223-00	Four (4) ounces of LabSolutions Neutralizing Acid Rinse (with MSDS)
14201-02	Elbow (1)

If you did not receive one or more of the components listed for your washer, or if any of the components are damaged, contact Labconco Corporation immediately for further instructions.

Removing the Shipping Skid

After you verify the washer components, move your washer to the location where you want to install it. Then, follow the steps listed below to remove the shipping skid from your washer.

Move the washer by placing a flat, low dolly under the shipping skid.

To remove the shipping skid:

1. Make certain any loose items inside the washer have been removed.
2. Gently place the washer on its back, positioning the washer on the shipping carton or other cushioning material.
3. Remove the four screws fastening the skid to the washer.

Retain the shipping skid until you test the various features of the washer.

Setting Up Your Washer

After you remove the skid from your washer, you must install either casters or leveling feet on the bottom of the washer. If you have an Undercounter or Freestanding

model, then you must level the washer and center the washer door. If you have an Undercounter model, you must also attach the washer to the countertop or worksurface.

Installing the Casters or Leveling Feet

M

If you have the Mobile model, the washer must rest on a level floor. Refer to Figure 3-1 and follow the steps below to install the casters on your washer.

To install the casters:

1. Locate the holes on the bottom of the washer where the four skid-fastening screws were previously attached.
2. Thread the four casters into these holes until the casters fit tightly.
3. Carefully move the washer into an upright position. Be careful to distribute the weight evenly on the casters when setting the washer upright.

Figure 3-1

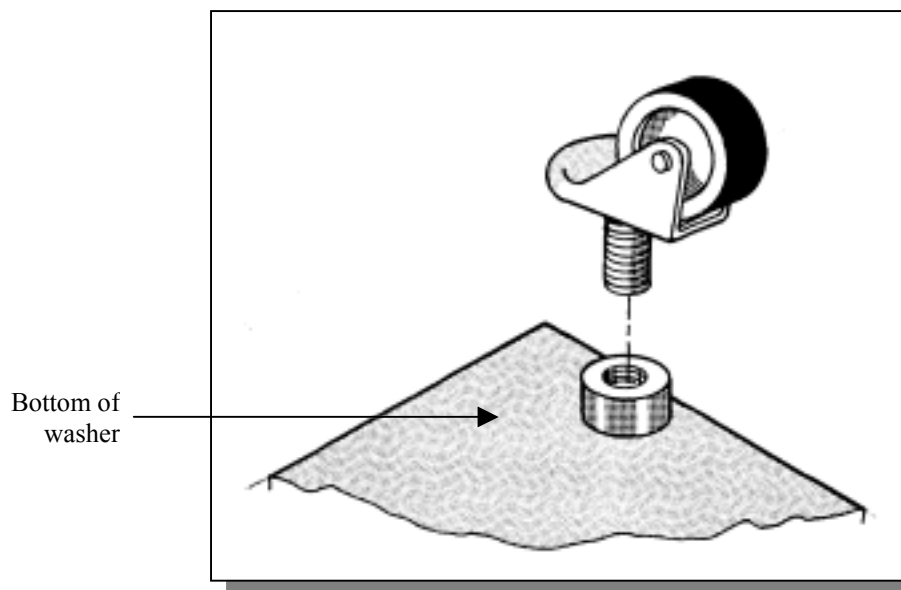

If you have the Undercounter or Freestanding model of the SteamScrubber or FlaskScrubber washer, refer to Figure 3-2 and follow the steps detailed below to install the leveling feet on your washer.



To install the leveling feet:

1. Locate the holes on the bottom of the washer where the four skid-fastening screws were previously attached.
2. Thread the four leveling feet into the holes.
3. Carefully move the washer into an upright position. Be careful to distribute the weight evenly on the leveling feet when setting the washer upright.

Figure 3-2

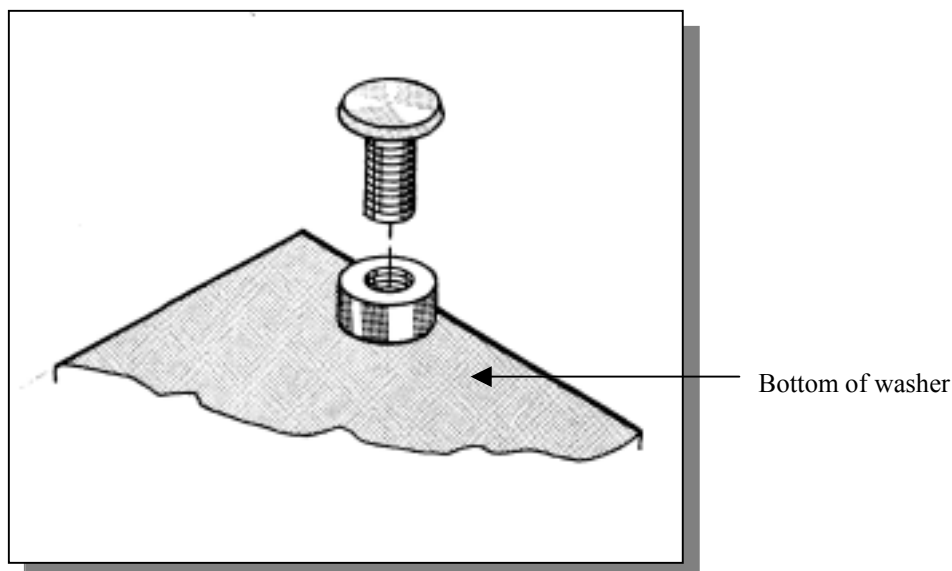

Leveling the Washer

F

If you have the Freestanding model of the SteamScrubber or FlaskScrubber Glassware Washer, after you have installed the leveling feet, you must level the washer by adjusting the leveling feet.

To level the washer:

1. Position the washer in its final installation site.
2. Place a carpenter level on the washer in the positions shown in Figure 3-3.

Figure 3-3

Position the level in both directions to ensure the washer is level front-to-back and side-to-side.

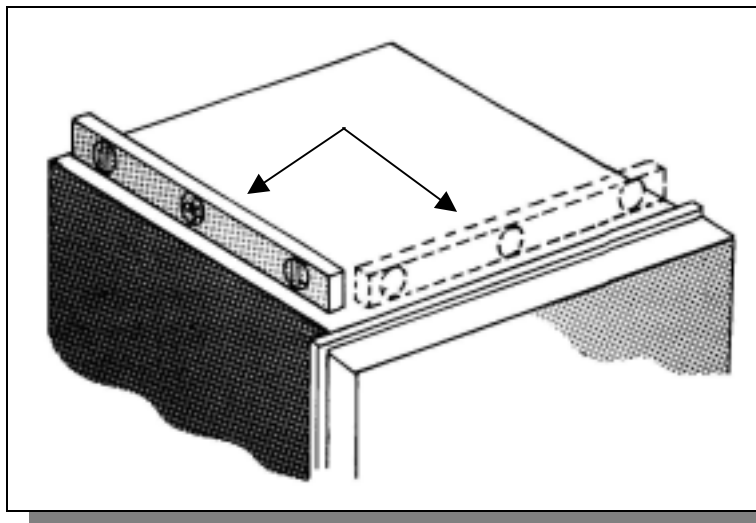

3. Turn the four leveling feet, as needed, to level the washer. A leveling foot is illustrated in Figure 3-4.

Figure 3-4

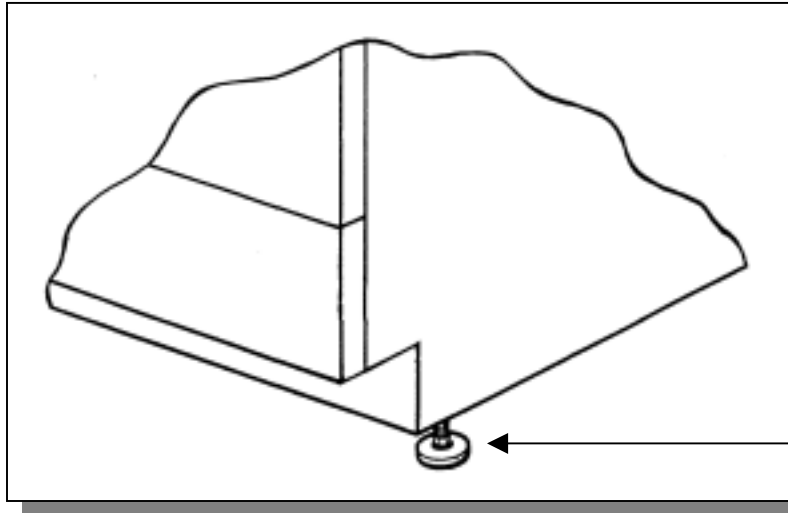

Turn the leveling foot clockwise to lower the washer and counterclockwise to raise the washer.

Leveling foot

If you have the Undercounter model, you may level it side-to-side by placing a short level on the inside top edge of the door. Refer to Figure 3-5 for the placement of the level on the washer.



Figure 3-5

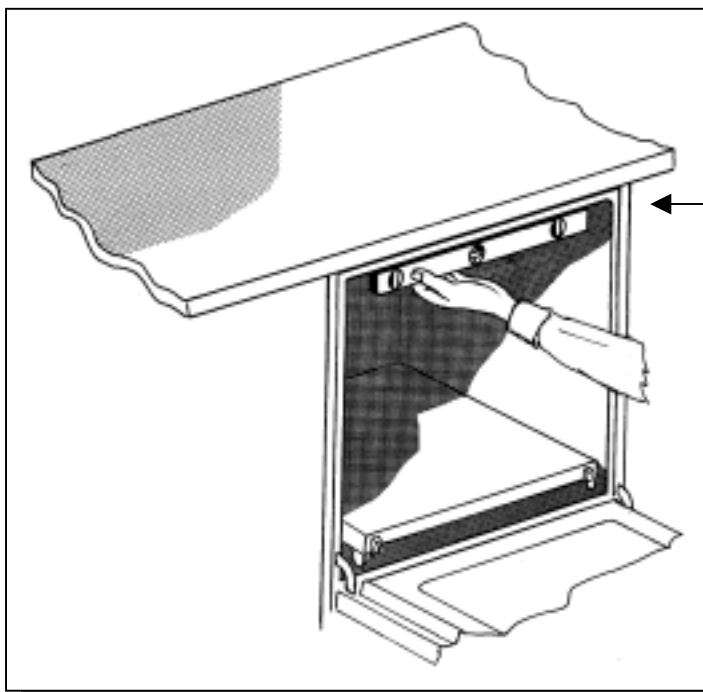

Position the level as shown to level the Undercounter model washer from side-to-side.

Centering the Washer Door

When the washer is level, check the operation of the washer door for alignment with the washer tank. If the door is not centered in the opening, you must center the door by adjusting the corresponding leveling foot. (For example, if the door hits the right side of the tank, raise the right front corner of the washer. If the door hits the left side of the tank, raise the left front corner of the washer.)

Attaching the Washer to the Countertop

U

If you have an Undercounter Glassware Washer, two screws have been provided to attach the front of the washer to the underside of the countertop or worksurface. After the washer is leveled in its final position and the washer door is properly centered, install the two screws as shown in Figure 3-6 to stabilize the unit and prevent it from moving.

Figure 3-6

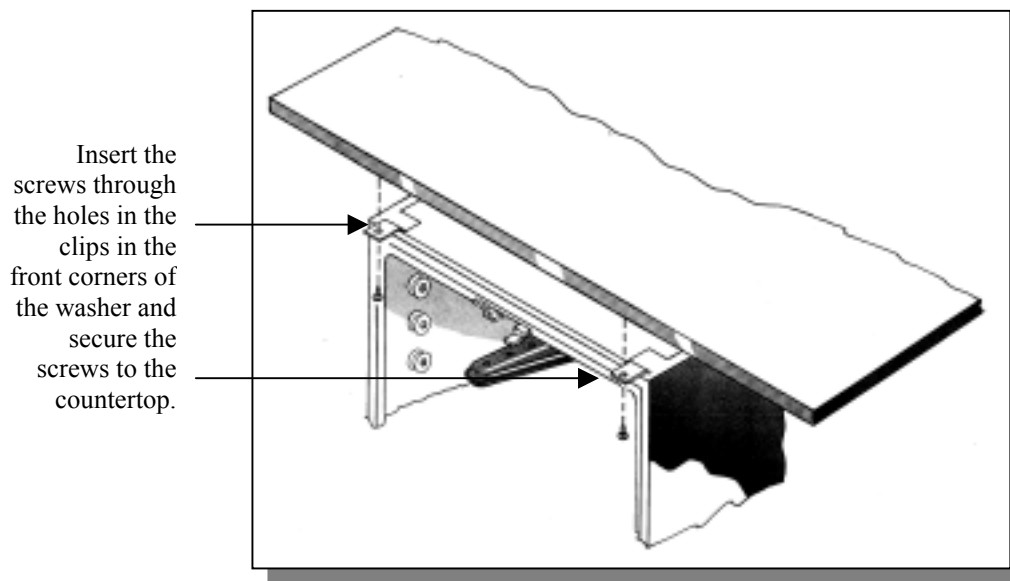

Connecting the Water Supplies

A hot water supply must be attached to your Glassware Washer. If you need purified water for the final rinse cycle, then you must also connect a purified water source to your washer.

Connecting the Hot Water

To prevent valve clogging, flush all of the hot water lines for your hot water supply source prior to connecting the washer to the water lines. The water supply valve to which the hot water supply must be connected is located in the lower right front corner of the washer. The lower panel of the washer must be removed to access the valve. To remove the panel, refer to Figure 3-7 and the instructions below.



Before continuing with this section, be certain your hot water source meets the requirements discussed in Hot Water Requirements in Chapter 2: Prerequisites.

To remove the lower panel:

1. Remove the two screws at the bottom of the lower panel of your washer.
2. Remove the panel by lifting slightly and pulling out.

Figure 3-7

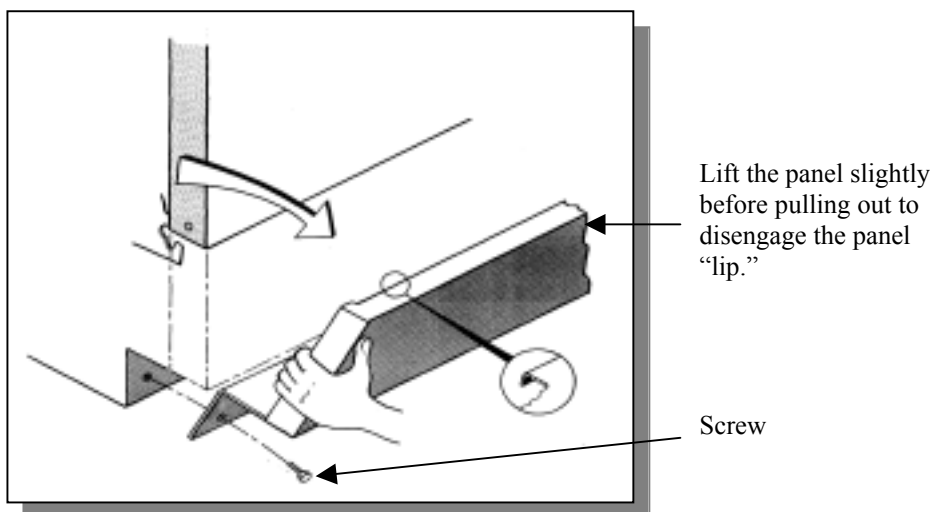

After you remove the lower panel, you are ready to connect the hot water source. Refer to Figure 3-8 and follow the instructions below to connect the hot water.

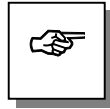

YOU MUST PROVIDE THE PLUMBING FITTINGS AND COMPONENTS NEEDED TO CONNECT THE HOT WATER SUPPLY SOURCE. THE WASHER HOT WATER SUPPLY VALVE IS EQUIPPED WITH A COMPRESSION FITTING ELBOW FOR A 3/8" OD TUBE.

To connect the hot water supply:

1. Be certain the hot water supply piping has been thoroughly flushed prior to connecting it to the washer. Debris in the piping can clog the washer valve.
2. Make the necessary plumbing connections to properly connect the hot water supply to the washer.
3. It may be necessary to place a loop in the supply tube if the shut off valve is behind the glassware washer. This will allow the washer to be slid in or out of its operating position.

Figure 3-8

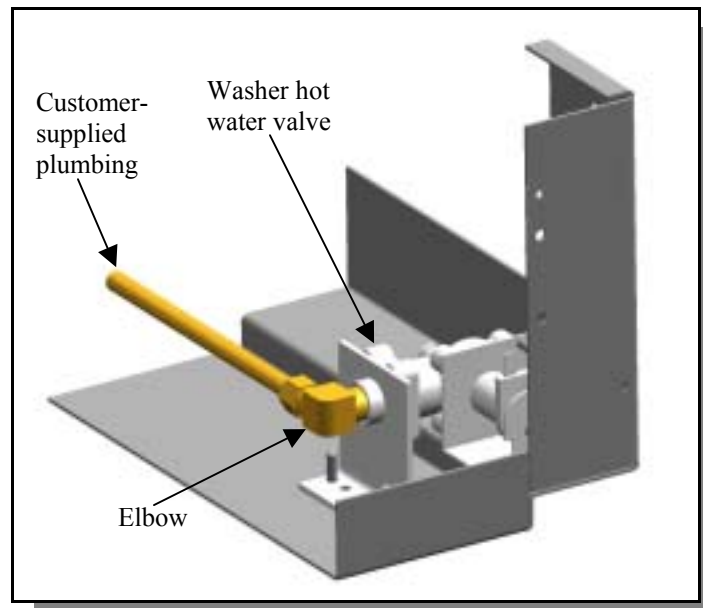

Connecting the Purified Water Supply

To prevent valve and pump clogging, flush all of the water lines for your purified water supply source prior to connecting the washer to the water lines. The water supply valve to which the purified water supply must be connected is located in the lower right front corner of the washer. The lower panel of the washer must be removed to access the valve. Refer to Figure 3-9 and follow the instructions below to connect the purified water source.

Before continuing with this section, be certain your purified water source meets the requirements discussed in Purified Water Requirements in Chapter 2: Prerequisites.

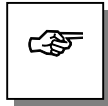

THE PURIFIED WATER INLET VALVE IS EQUIPPED WITH A PLASTIC HOSE BARB CONNECTION TO ACCOMMODATE 3/8" (9.5 MM) ID FLEXIBLE PLASTIC OR RUBBER HOSE. THE HOSE CONNECTION MAY BE REMOVED FROM THE VALVE TO EXPOSE A MALE 3/4" - 11-1/2 NH HOSE COUPLING. RIGID PLASTIC, TIN-LINED, OR STAINLESS STEEL TUBING AND FITTINGS MAY BE CONNECTED TO THE WASHER FITTING.

Figure 3-9

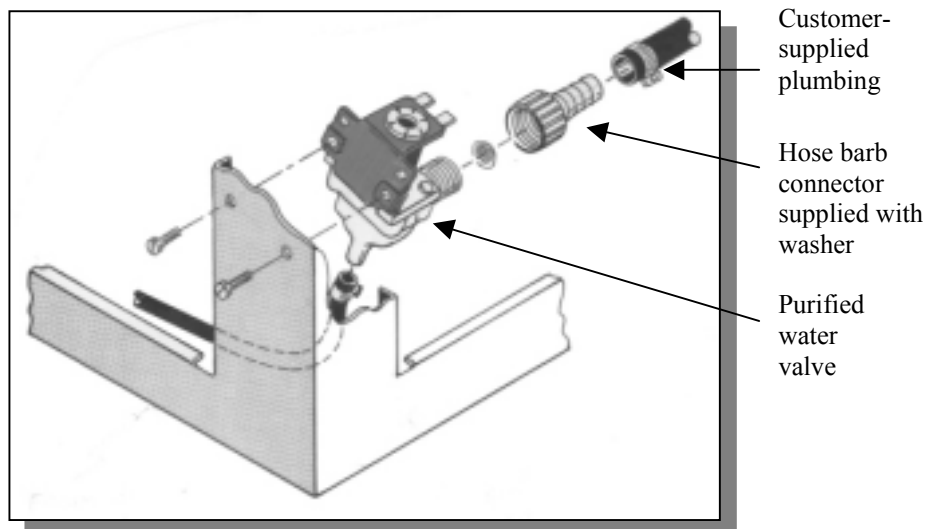

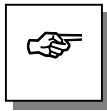

AT LEAST 1.25 GALLONS (4.7 LITERS) PER MINUTE OF PURIFIED WATER FLOW IS REQUIRED. AT LEAST 5 GALLONS OF PURIFIED WATER MUST BE AVAILABLE FOR EACH WASH CYCLE. A 3/8" ID PIPE IS THE MINIMUM RECOMMENDED.

M

If the washer is a Mobile model and is moved to various locations, and if purified water is used, provisions must be made to use a flexible hose from a source of house-purified water. If a carboy is used, place the carboy on a carboy cart and move it with the washer. Be careful not to let the hose kink or become damaged.

If you do not use purified water during the washer cycle, you may want to disconnect the purified water pump. Refer to the section, Disconnecting the Purified Water Pump in Chapter 6: Modifying Your Washer.

To connect the purified water supply:

1. Make certain the purified water supply piping has been thoroughly flushed prior to connecting it to the washer.
2. Remove the two screws at the bottom of the lower panel of your washer, as shown in Figure 3-7.
3. Remove the panel by lifting slightly and pulling out.
4. Make the necessary plumbing connections to properly connect the purified water supply to the washer.

NOTE: If the purified water source is a carboy, complete steps 5 and 6.

5. Connect the purified water source through either the top or the bottom of the carboy, as illustrated in Figures 3-10 and 3-11. If the purified water supply feeds directly from the carboy top, make certain the hose is submerged under the water line. Attach a weight to the end of the tubing, as shown in Figure 3-11, to keep it from floating on top of the water and possibly allowing air into the system.
6. Make certain the top of the carboy is vented to permit proper flow from the carboy to the washer.

Figure 3-10

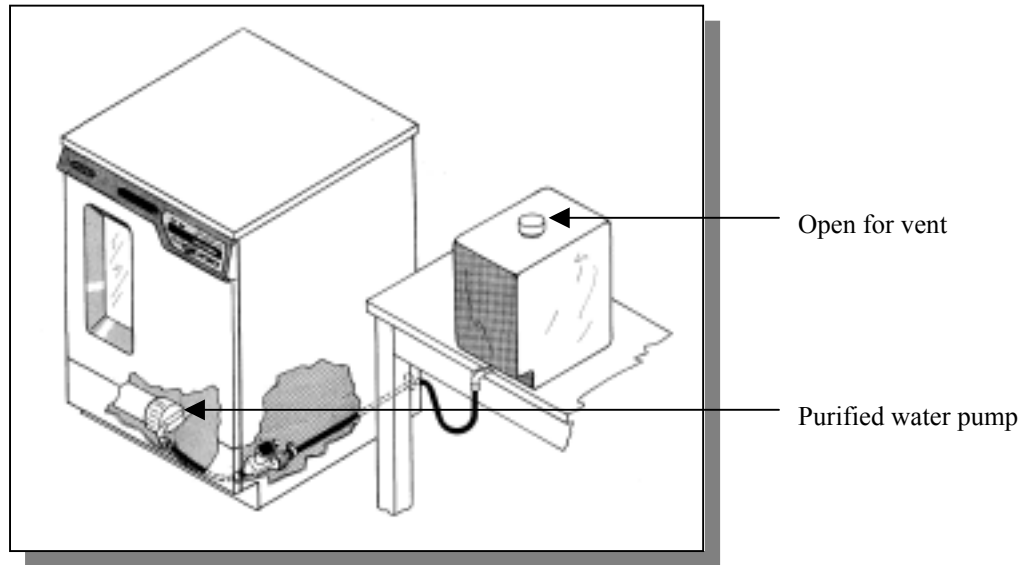

Example of a Bottom Feed Connection

Figure 3-11

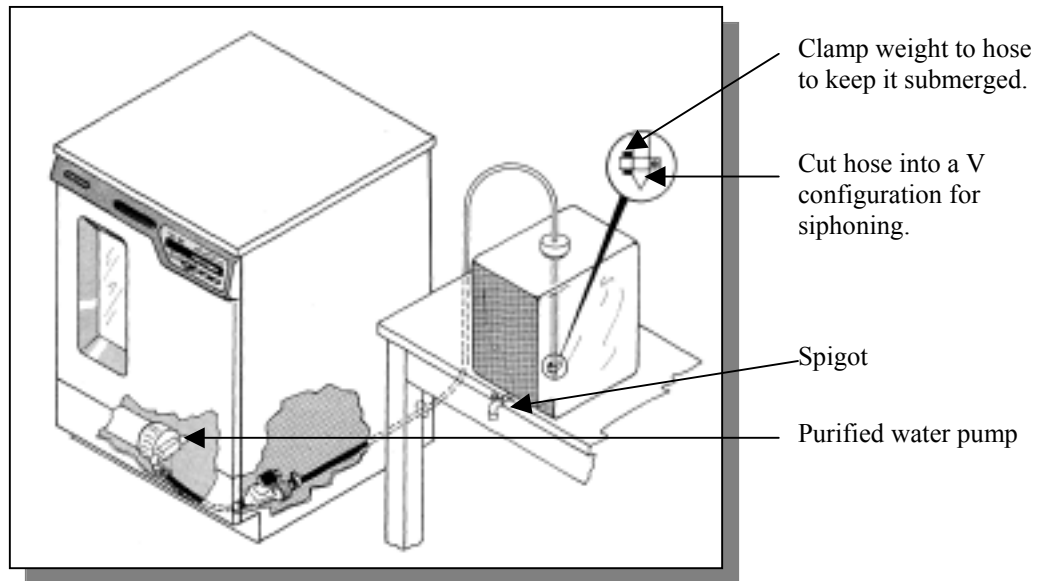

Example of a Top Feed Connection

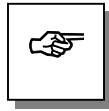

MAKE CERTAIN THAT ALL OF THE CONNECTIONS ON THE PURIFIED WATER SYSTEM ARE AIR TIGHT. THE PUMP MUST NOT PULL AIR INSTEAD OF WATER. MAKE CERTAIN THE SUPPLY HOSE IS NOT CRIMPED.

M

Installing Faucet Adapters

If you purchased a Mobile Glassware Washer, you need to install a faucet adapter to provide a quick disconnect high-pressure coupling between the faucet and the hose-end fill/drain connector on your washer. Examples of two faucet adapter configurations are shown in Figure 3-12.

Figure 3-12

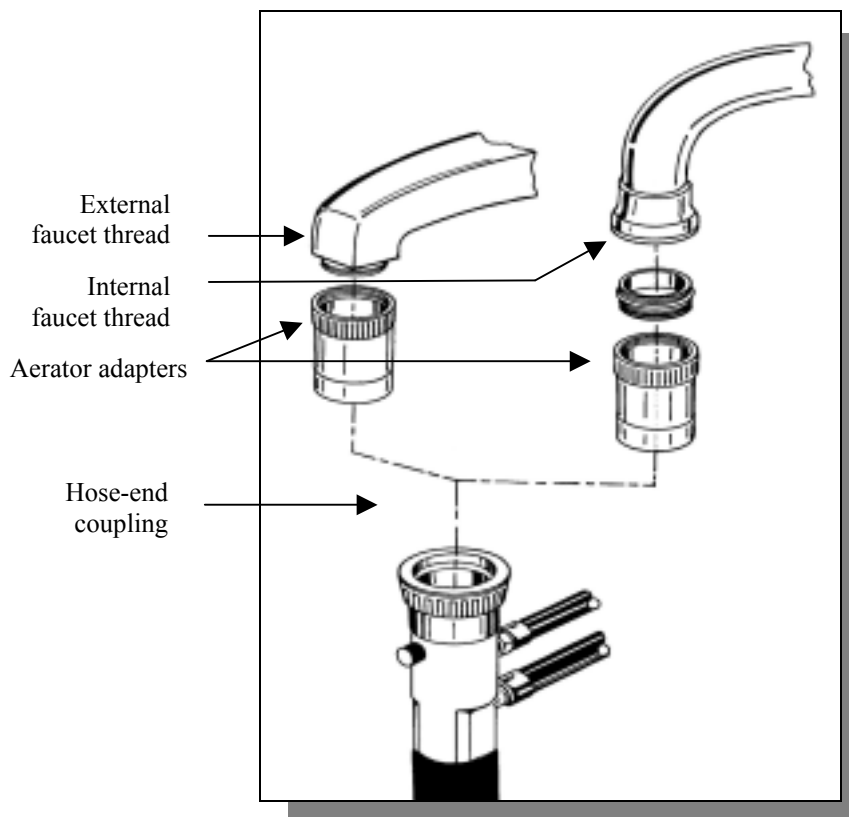

An aerator adapter and a standard-size adapter fitting are provided with your Mobile washer. If the adapter fitting provided does not allow for a tight connection to your faucet, a variety of internally and externally threaded fittings are available at your local hardware store. Use caution when installing the fittings to prevent stripping the threads.

Attaching the Hose-End Coupling

After you have installed the faucet adapter, the hose-end coupling of your washer (shown in Figure 3-12) attaches and seals to the aerator adapter by pushing the parts together. The hose-end coupling must be snapped into place **BEFORE** turning on the hot water faucet. Turn the hot water on **SLOWLY** until the faucet is completely open.

Connecting the Drain Hose



Before continuing with this section, be certain that your drain meets the requirements detailed in *Drain Requirements* in *Chapter 2: Prerequisites*. The washer drain hose is connected to a fitting on the rear side of the pump/motor assembly.

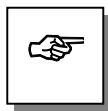

BE CERTAIN YOU CONFORM TO ALL LOCAL PLUMBING CODES WHEN YOU ROUTE AND CONNECT THE DRAIN.

The drain hose is installed at the factory. The hose provides a flexible coupling to the drain piping and can be secured with a spring or band hose clamp. (A band hose clamp is provided with your washer.)

Tubing or pipe ½" (1.3 cm) ID should be used for the drain.

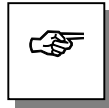

DO NOT ROUTE THE DRAIN TO AN ELEVATION MORE THAN 30" (76 cm) ABOVE THE PUMP DISCHARGE. DO NOT REDUCE THE SIZE OF THE DRAIN PLUMBING.

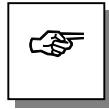

DO NOT REMOVE THE HOSE FROM THE CLAMP ON THE REAR OF THE GLASSWARE WASHER.

The use of an air gap is strongly recommended for all installations to prevent the siphoning of waste water into the washer.

The drain piping can be routed to either a sink or a floor drain. If you route the drain piping to a sink drain without using an air gap, the highest point of the drain pipe must be above the sink drain, as shown in Figure 3-13.

Figure 3-13

If an air gap is not used, the drain line must be elevated above the water level of the sink.

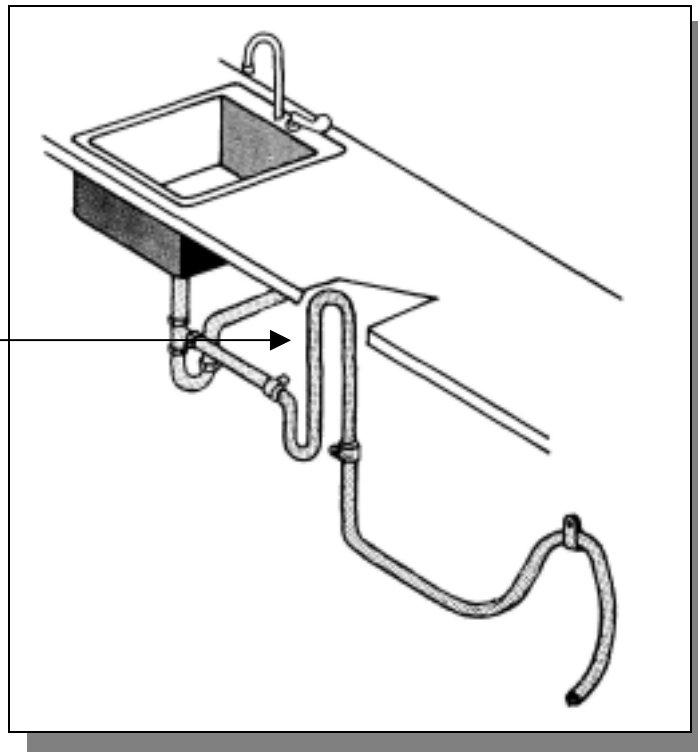

If you route the drain piping to a sink drain and use an air gap, refer to Figure 3-14 for the placement of the air gap.

Figure 3-14

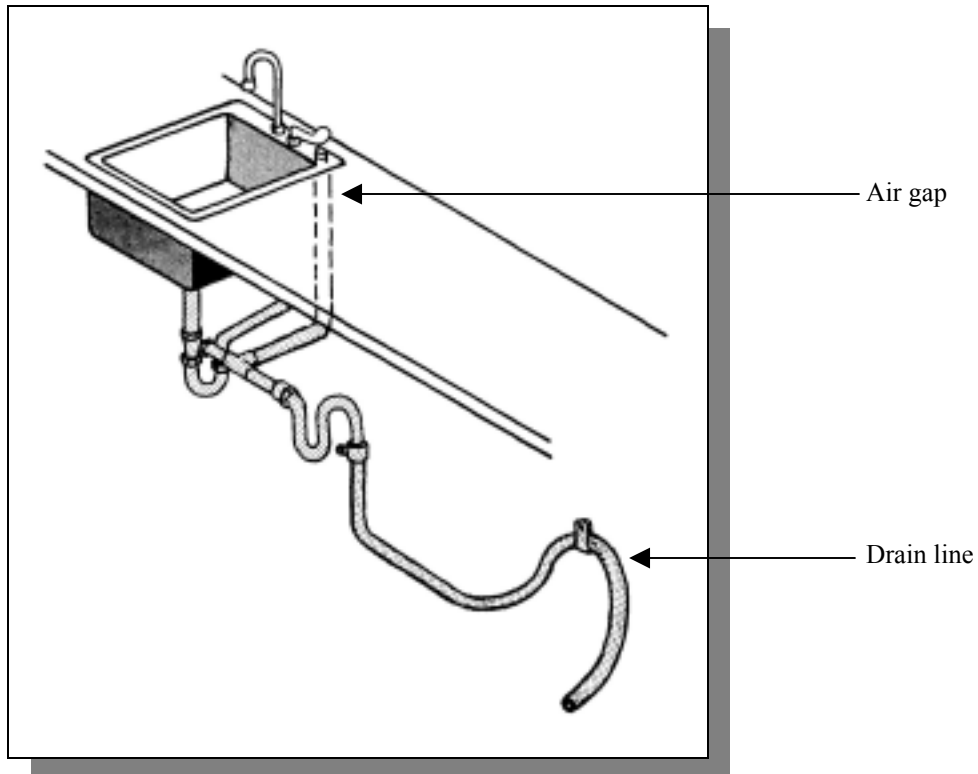

If you route the drain piping to a floor drain, refer to Figure 3-15 for placement of the drain tubing and trap.

Figure 3-15

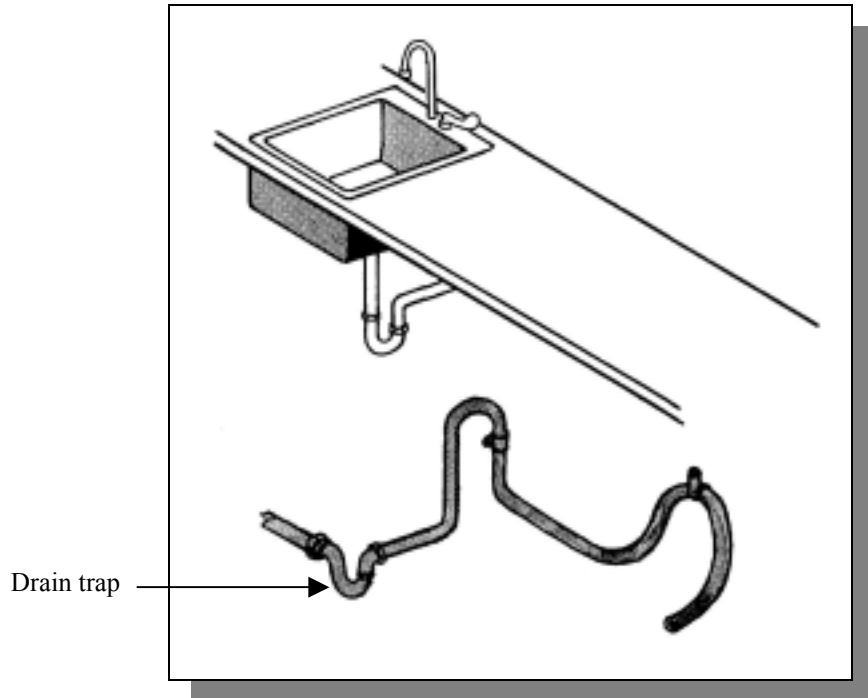

Connecting the Power Supply

Before continuing with this section, be certain your power supply meets the requirements specified in *Electrical Requirements* in *Chapter 2: Prerequisites*. Undercounter and Freestanding Washers should be hard-wired directly into a junction box. Refer to Figure 3-16 and follow the steps below to connect your washer to the appropriate power source.

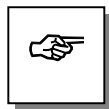

BE CERTAIN THAT YOU CHECK AND CONFORM TO ALL LOCAL ELECTRICAL CODES. DO NOT DISTURB ANY INTERNAL WIRING IN THE WASHER.

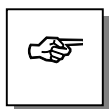

THE SUPPLY CIRCUIT MUST CONSIST OF NUMBER 12 AWG 3-WIRE CABLE OR HEAVIER. WASHERS MUST BE CONNECTED TO A SERVICE WITH A 20 AMP CIRCUIT BREAKER OR FUSE.

Wire must comply with all local electrical codes. Type THW or THWN wire may be used if it complies.

To connect the electrical supply:

1. Remove the lower panel on the washer by removing the two screws located at the bottom of the panel, as shown previously in Figure 3-7.
2. Lift the panel slightly and pull outward.
3. Remove the cover over the electrical junction box, shown in Figure 3-16, by removing the two screws.
4. On 115V models, connect the customer-supplied power wires to the black and white wires, using wire nuts. On 230V models, attach customer-supplied power wires to the brown and blue wires, using wire nuts.
5. Connect the customer-supplied ground wire to the green screw.

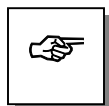

CUSTOMER-SUPPLIED WIRES MUST BE CLAMPED TO THE HOLE WHERE THEY PASS THROUGH THE REAR OF THE JUNCTION BOX, IF PRESCRIBED BY LOCAL CODES. IF IT IS NECESSARY TO USE A BUSHING WITH AN INTEGRAL CLAMP AT THE INLET TO THE JUNCTION BOX, REMOVE THE PLASTIC BUSHING SUPPLIED WITH THE WASHER BEFORE INSTALLING THE NEW BUSHING.

6. Replace the cover on the electrical junction box.
7. Replace the lower panel on the washer.

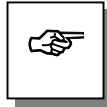

BEFORE TURNING ON THE WASHER, MAKE CERTAIN THE WATER IS TURNED ON AND NO PACKING MATERIAL REMAINS INSIDE THE WASHER.

Figure 3-16

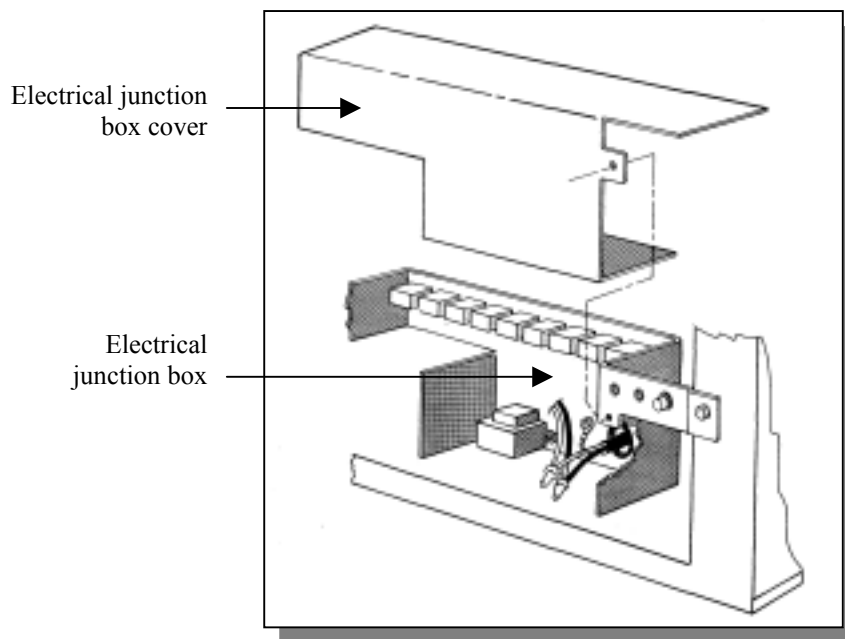

Testing Your Washer

Now that you have made the required water and electrical connections to your washer, you need to test the operation of the washer. A series of diagnostic steps are provided in this section.



If the washer is interrupted in the middle of the diagnostic steps, wait 4 to 5 seconds before opening the washer door to prevent hot water from splashing out. The hot water and steam from the washer may cause scalding.

Connecting the Hose-End Coupling

M

If you purchased a Mobile Glassware Washer, the first action you must take is to connect the hose-end coupling to the hot water faucet. Snap the hose-end coupling onto the aerator adapter on the faucet by pushing the parts together, as shown previously in Figure 3-12. After the hose-end coupling is attached to the faucet, slowly turn on the hot water faucet.

Running the Diagnostics

To ensure your washer is operating properly, it is recommended that you perform the diagnostics procedure detailed below, which should take approximately 10 minutes to complete. Refer to Figure 3-17 to familiarize yourself with the control panel before you begin the procedure.

Figure 3-17

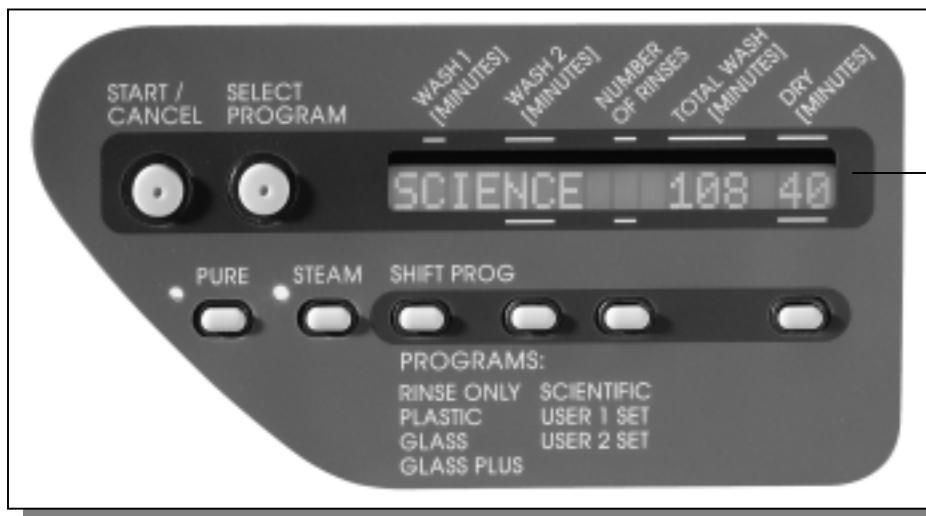

The Scientific wash cycle is selected. The wash will run a total of 108 minutes, with a 40 minute drying time.

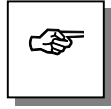

BEFORE OPERATING THE WASHER WITH THE PURIFIED WATER OPTION SELECTED, CHECK THE PURIFIED WATER SUPPLY FOR AMPLE QUANTITY.

To run the diagnostics test:

1. Locate the control panel on the front of your washer.
2. Press and hold the bottom right button and close the handle of your washer by sliding the door latch knob to the right.
3. The display window should read: PRESS SELECT: TST.
4. Press the Select Program button.
5. The display window should read: FILL VIA TAP. Tap water should be heard entering the washer. Allow tap water to enter for approximately one minute.
6. Press the Select Program button.
7. The display window should read: DE-ION PUMP ONLY.
8. Press the Select Program button.
9. The display window should read: FILL VIA DE-ION. De-ionized (DI) water enters the washer and the DI pump should be heard. After approximately 4 minutes the float switch should turn off the flow of DI water.
10. Press the Select Program button.
11. The display window should read: PUMP - ON: WASH. The wash cycle should activate.
12. Press the Select Program button.
13. The display window should read: PAUSE. All washer functions should be off.
14. Press the Select Program button.
15. The display window should read: PUMP - ON: DRAIN. The water drains from the washer. Allow all the water in the washer to drain. You can tell when this occurs when the sound of the pump changes.
16. Press the Select Program button.
17. The display window should read: DETERGENT CUP. Within a minute, you should hear the detergent cup lid open.

18. Press the Select Program button.
19. The display window should read: HEAT – HIGH
T’STAT and the heater activates.
20. Press the Select Program button.
21. The display window should read: HEAT – LOW
T’STAT and the heater activates.
22. Press the Select Program button.
23. The display window should read: BLOWER ON. The
washer blower should be heard.
24. Press the Select Program button.
25. The display window should read: DONE. Open the
door latch to turn off the electronics, or select a wash
cycle and use the washer.

Disconnecting the Hose-End Coupling



If you purchased a Mobile Glassware Washer, you can choose to disconnect the hose-end coupling from the hot water faucet after the diagnostics procedure is completed. Refer to Figure 3-18 and the instructions below to disconnect the hose-end coupling.

To disconnect the hose-end coupling:

1. Turn off the hot water faucet.
2. Push the pressure relief button on the hose-end coupling to relieve the water pressure.
3. Pull down on the plastic release ring on the hose-end coupling to disconnect it from the faucet.

Figure 3-18

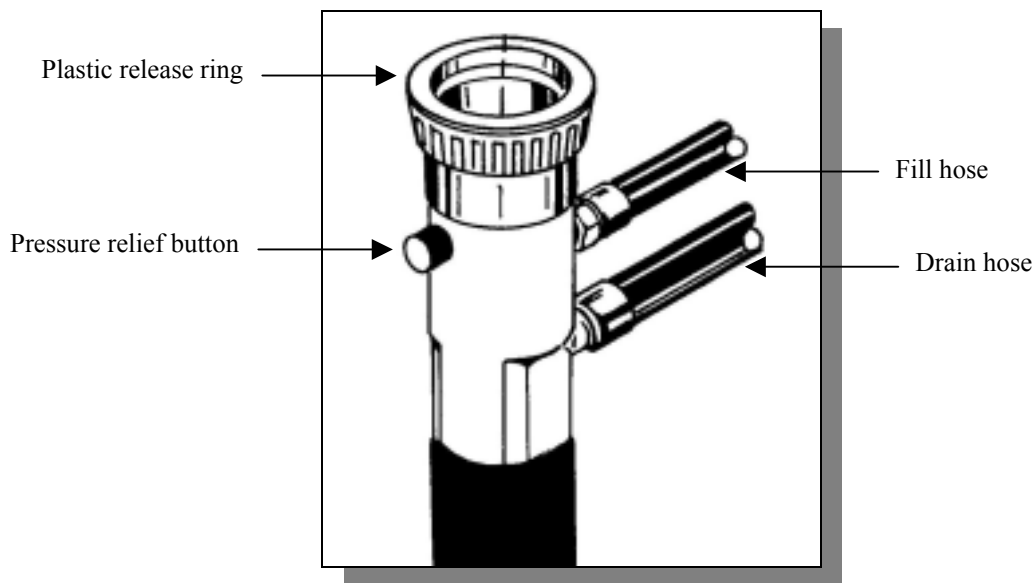

Your Next Step

The installation and setup of your Glassware Washer is now complete. To learn how to load and operate your washer, proceed to *Chapter 4: Using Your Washer*. To make a modification to the configuration of your washer, proceed to *Chapter 6: Modifying Your Washer*. To perform additional diagnostics on your washer, proceed to *Chapter 7: Troubleshooting*. To learn about the maintenance requirements for your washer, proceed to *Chapter 5: Maintaining Your Washer*.

CHAPTER 4

USING YOUR WASHER

After your washer has passed the basic diagnostics test detailed in *Chapter 3: Getting Started*, you are ready to begin using your washer. Read this chapter to learn how to:

- arrange the racks inside your washer to meet your specific needs.
- properly position glassware inside your washer.
- fill the detergent and neutralizing acid dispensers.
- interrupt a wash cycle after it has begun.
- select an operating cycle.



Do not use the Glassware Washer in a manner not specified by the manufacturer. The electrical protection properties of the washer may be impaired if the washer is used inappropriately.

Arranging the Washer Racks

The FlaskScrubber and SteamScrubber are equipped with different rack configurations to accommodate the various types of laboratory glassware. In addition to the standard configuration of the Glassware Washers, many optional racks and inserts are available to customize your washer to

best suit your needs. For a complete list of available rack accessories, refer to *Appendix D: Glassware Washer Accessories*.

If you purchased a SteamScrubber, proceed to the following section, *The SteamScrubber Racks*. If you purchased a FlaskScrubber, proceed to the section, *The FlaskScrubber Racks*, later in this chapter.

The SteamScrubber Racks

The SteamScrubber is equipped with two racks (a top rack and a bottom rack). The top rack of the SteamScrubber Glassware Washer is designed to accommodate beakers and other wide-mouth laboratory glassware. The top rack is not recommended for narrow-necked glassware.

The bottom rack of the SteamScrubber Glassware Washer is designed to accommodate flasks, beakers, culture tubes, graduated cylinders, Erlenmeyer flasks, petri dishes, watch glasses, BOD bottles, and a variety of other laboratory glassware. There are a variety of inserts that are available to accommodate the various types of glassware, as detailed in *Appendix D*.

Lowering the Top Washer Arm and Top Rack

The top rack of your SteamScrubber may be lowered to accommodate taller glassware. Perform the steps listed below to lower the washer arm and the top rack. Refer to Figure 4-1 for help in lowering the washer arm. Figure 4-2 illustrates how to remove the rail bumpers. Refer to Figure 4-2 for help in lowering the top rack rails.

To lower the top washer arm and the top rack of the SteamScrubber:

1. Open the washer door by sliding the latch knob to the left. Pull the door toward you and down.
2. Depress the button on the right side of the upper wash arm tower, as illustrated in Figure 4-1.
3. Lower the upper portion of the tower and the wash arm by gently pushing down.

Figure 4-1

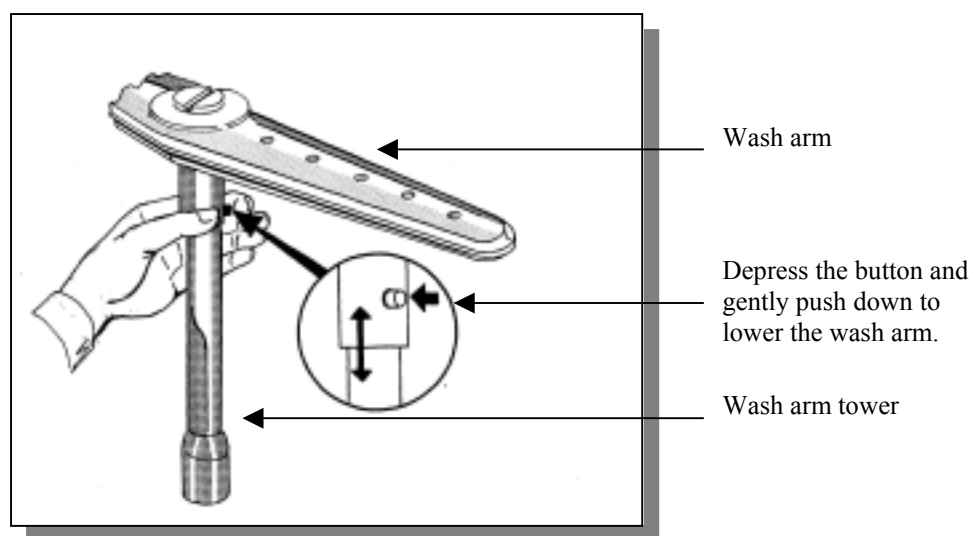

4. Secure the wash arm by clicking the wash arm into the upper hole in the wash arm support tube.
5. Remove the rubber bumper at the front of each side rail, as shown in Figure 4-2.

Figure 4-2

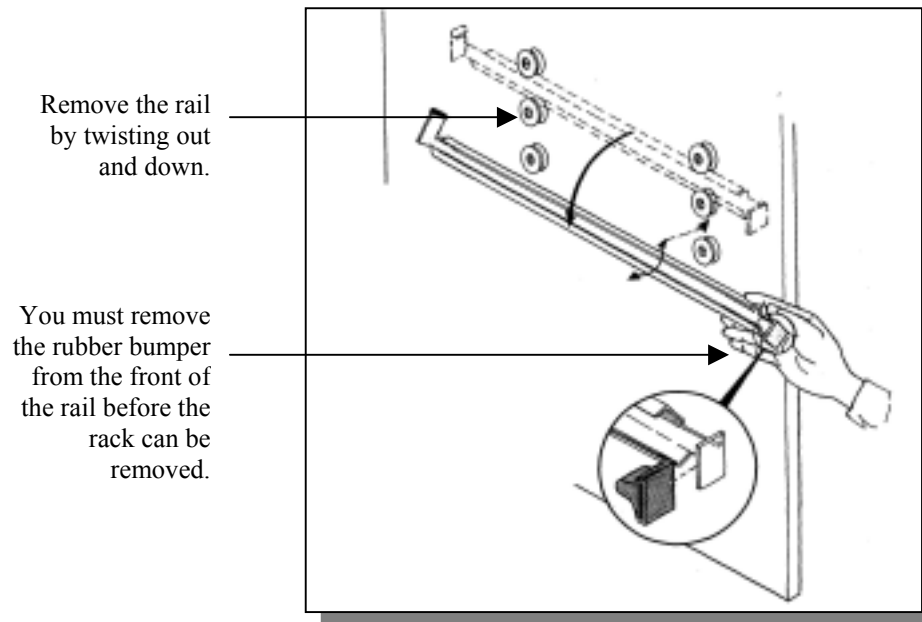

6. Pull the upper rack forward and lift the front until the wheels disengage from the track.
7. With a twisting motion, remove the rails from the rollers on each side of the tank, as shown above in Figure 4-2.
8. Reposition the rails on the lower set of rollers and with a twisting motion insert them in the rollers.
9. Place the rack rollers in the rails.
10. Replace the rubber bumpers.

The FlaskScrubber Rack

The FlaskScrubber Glassware Washer is equipped with a spindle rack and four glassware holders. The FlaskScrubber spindle rack is designed for narrow-necked glassware such as volumetric flasks, Erlenmeyer flasks, graduated cylinders, Kjeldahl flasks, test tubes, and digestion tubes.

Two sizes of spindles are provided with the washer: twenty-four 1/4" OD and ten 1/8" OD spindles. The glassware holders that are included with your Glassware Washer allow for the positioning and washing of beakers and other wide-mouth glassware. The optional Multi-Pin Insert, part number 44049-01, may be positioned over spindles. Figure 6-9 illustrates the placement of the Multi-Pin Insert. The spindles can be removed with a screw driver and replaced with the plugs included with the washer.

Figure 4-3

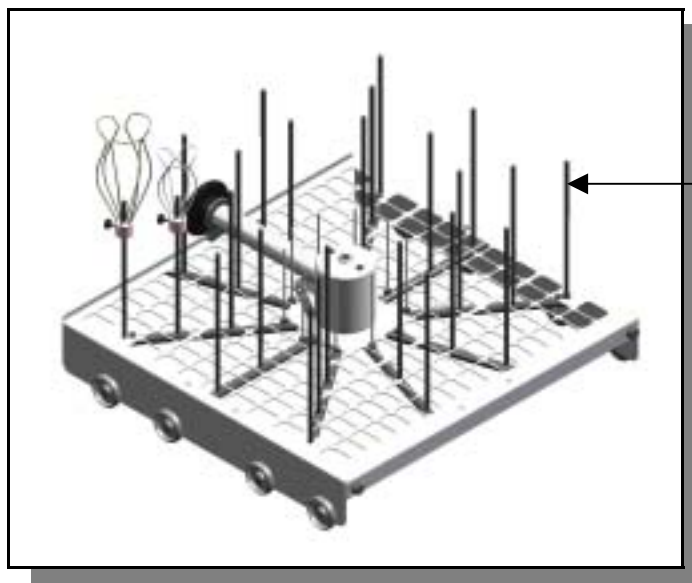

To remove a spindle, insert a screwdriver into the slot on the top of the spindle and turn counter-clockwise. After removing the spindle, thread a nylon plug into the resulting hole.

Optional top racks are available for the FlaskScrubber to expand the washer's capacity to accommodate many types of glassware. An Upper Spindle Rack is available with 24 spindles and an upper rack is available with 24 pins.



IF THE MULTI-PIN INSERT IS INSTALLED ON THE BOTTOM RACK AND THE OPTIONAL UPPER RACK IS USED, DO NOT HEAVILY LOAD THE MULTI-PIN INSERT WITH WIDE MOUTH GLASSWARE. THIS MAY RESTRICT WATER FLOW FROM THE LOWER DISTRIBUTION ARM TO THE GLASSWARE IN THE UPPER RACK.

Loading Glassware into the FlaskScrubber

To load glassware onto a spindle, place the glassware on the spindle and adjust the position by raising or lowering the spring clip, as shown in Figure 4-4. The outlet of the spindle should be as close to the center of the flask as possible. Do not allow the glassware to rest on the tip of the spindle.

Figure 4-4

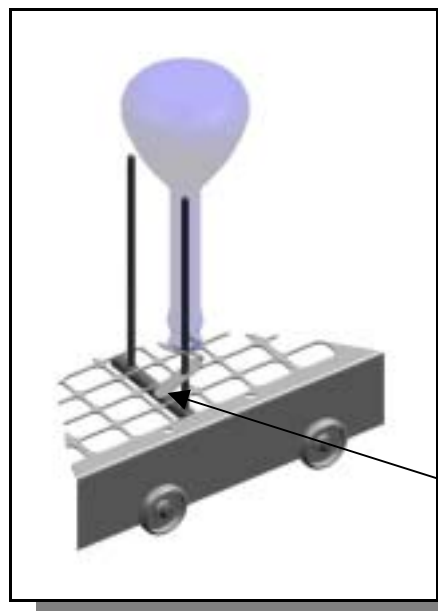

Squeeze the spring clip together and raise or lower the clip to position the glassware properly.

Two large and two small Glassware Holders are supplied with each FlaskScrubber. These holders enable you to place wide-mouth glassware onto the FlaskScrubber spindles. To position glassware in a glassware holder and install the holder on a spindle, refer to Figure 4-5 and follow the instructions below.

To use a Glassware Holder:

1. Press the glassware into the holder; the clamps should spring out and grip the glassware.
2. Loosen the set screw in the hub, as shown in Figure 4-5, and raise or lower the holder to position the spindle near the center of the glassware. Do not allow the glassware to rest on the tip of the spindle.
3. Re-tighten the set screw.

Figure 4-5

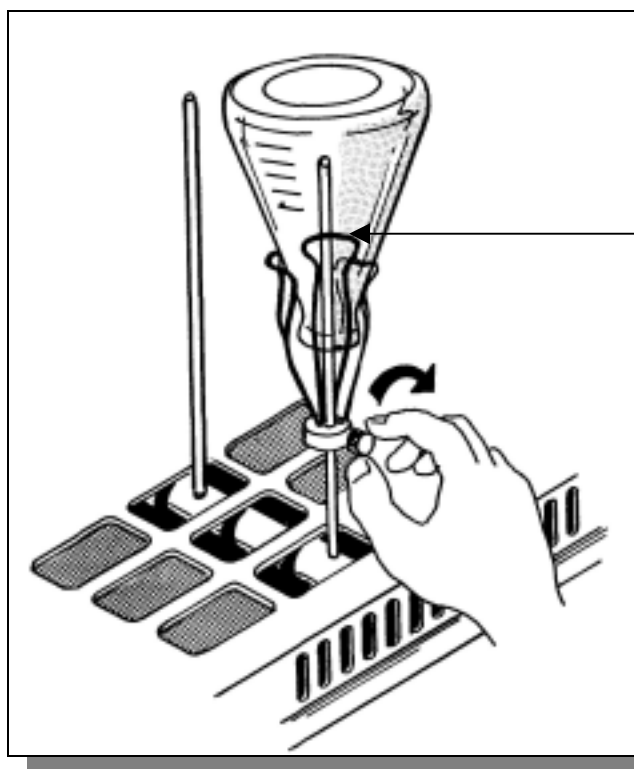

Press the glassware into the glassware holder. Then, turn the set screw counterclockwise to loosen the glassware holder hub. Position the glassware holder so that the spindle is near the center of the glassware. Turn the set screw clockwise to tighten the glassware holder in place.

Glassware should be loaded so that it does not touch each other during a wash cycle. The washer has been designed for quiet operation. To prevent noise and glass breakage, be certain that the glassware does not touch.

Place heavily soiled items toward the center of the racks. Place lightly soiled items in the corners.

The Detergent Dispenser

Your Glassware Washer is equipped with a detergent dispenser that contains a main wash cavity and a neutralizing solution port, as shown in Figure 4-6. In addition, the washer door has a depression where detergent may be added for use during the first wash of the cycle.

Figure 4-6

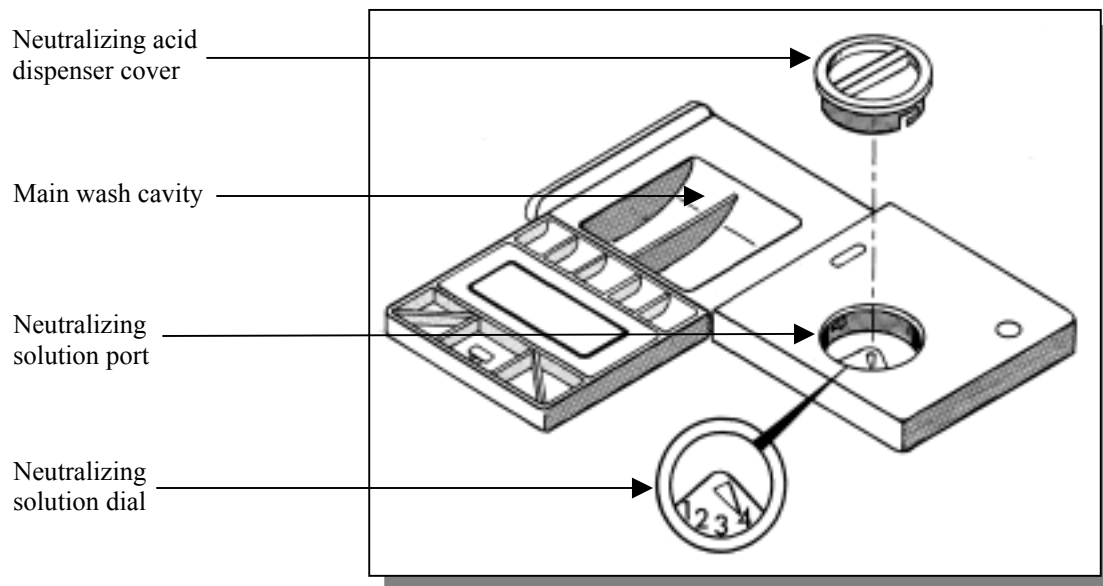

The detergent dispenser opens during the second wash cycle, except when the Plastic cycle is selected, which has only one wash cycle. If your glassware is heavily soiled, you may want to add powder detergent to the pre-wash cavity. Do not use liquid detergent in the pre-wash cavity in the washer door. The initial drain and fill cycle will flush the liquid detergent out of the washer prior to the first wash. Refer to the table below to determine which cavities to fill, based on the selected wash choice. You may use either the pre-wash cavity stamped in the washer door or the one on the lid of the detergent cup.

Wash Cycle	Fill Pre-wash Cavity	Fill Main Cavity
Rinse Only	NO	NO
Plastic	NO	YES
Glass	OPTIONAL	YES
Glass Plus	OPTIONAL	YES
Scientific	OPTIONAL	YES
User 1	OPTIONAL	YES
User 2	OPTIONAL	YES



Do not use combustible solvents in the Glassware Washer. If soiled glassware contains flammable compounds, rinse the glassware thoroughly prior to placing the glassware into the washer. Heaters in the washer are very hot and could cause a fire.

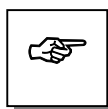

ALWAYS RINSE GLASSWARE THOROUGHLY BEFORE PLACING THE GLASSWARE INTO THE WASHER. PETROLEUM BASED COMPOUNDS MAY DEGRADE CERTAIN INTERNAL WASHER COMPONENTS.

Non-foaming powder or liquid detergent formulated for labware washers, in conjunction with adequate hot water, is vital for obtaining clean glassware. If the water is soft, less detergent may be needed. Too much detergent with softened water may cause etching of the glassware. This appears as a permanent cloudy film on the glassware.

To achieve the best results with your Glassware Washer, use Labconco's LabSolutions Detergent.

Store detergent in a cool, dry place. Immediately replace the detergent container lid after dispensing. If lumps develop due to exposure to moisture, discard the detergent according to local regulations.

Fill the main detergent cavity three-fourths full if the water hardness grains per gallon (GPG) for your water measures 0 – 4 GPG (soft water). Fill the detergent cavity completely if your water measures 4 GPG or higher (medium to hard water). If you use the pre-wash cavity stamped in the washer door, fill it completely.



To open the detergent dispenser, gently slide the white tab sideways. If the tab is pulled upward or perpendicular to the door, it will break.

Filling the Neutralizing Acid Dispenser

If it is necessary to neutralize the alkalinity of the detergent, a mild or weak acid may be placed in the detergent cup neutralizing dispenser from which it will be dispensed during the first rinse. If pure water rinse is selected, the last two rinses will be made with pure water. To avoid dispensing neutralizing acid during a pure rinse, more than two rinses should be selected. The dispenser holds approximately 170 ml and should be checked and replenished as needed. To fill the neutralizing acid dispenser, refer to Figure 4-6 and follow the instructions below.

To fill the neutralizing acid dispenser:

1. Twist and pull up on the cap to remove the round cover on the neutralizing solution port.
2. Fill the cavity with LabSolutions Neutralizing Acid Rinse, part number 45222-00, 1M citric acid or 10% phosphoric acid until the level of the liquid rises and is visible in the port.
3. Set the dial to read 4 ml.
4. Replace the cover.

Selecting an Operating Cycle

The microprocessor control on your Glassware Washer allows you to select one of four factory preset wash cycles, to custom program two additional cycles, or to run a rinse-only cycle. The control panel is shown in Figure 4-7.

Figure 4-7

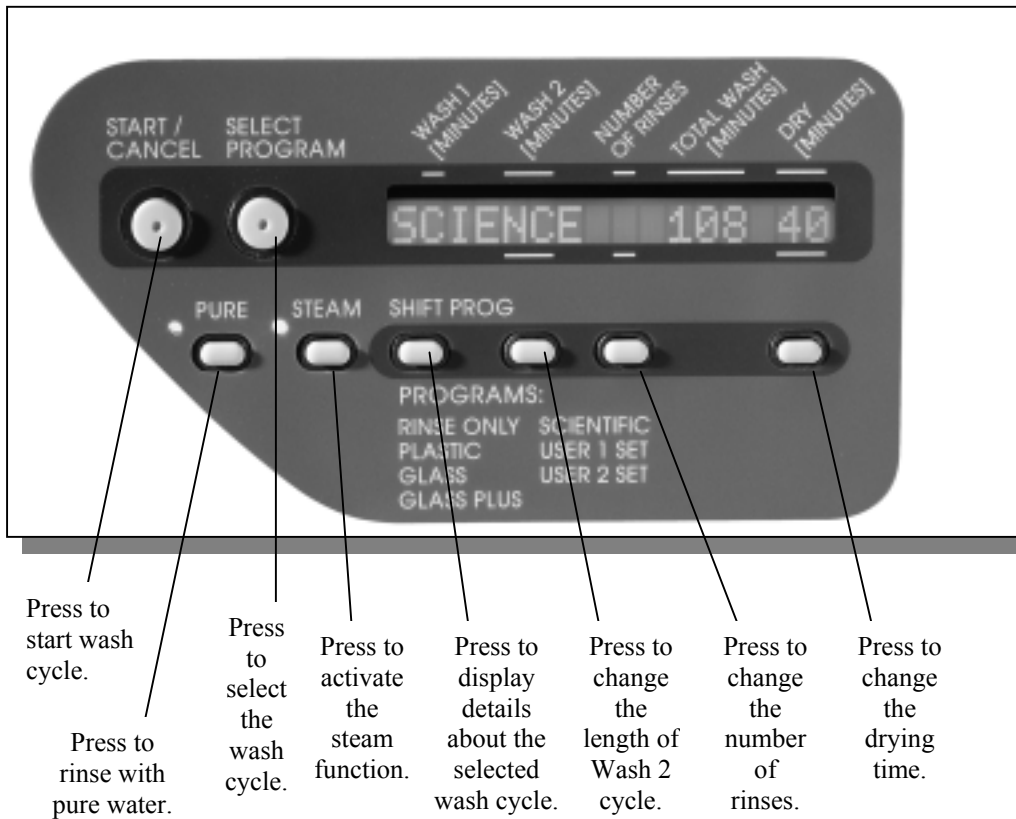

Programming and Starting a Wash Cycle

Refer to *Appendix C: Glassware Washer Specifications* for complete details on the various factory-set programs and the options available for customizing cycles. After you have decided which washer cycle you need to use, follow the instructions below to start your washer.

Washers built for use on 230V have the capability to wash glassware at a temperature of 180°F (82°C). They also are able to operate at the lower temperature of 140°F (60°C) which is the standard temperature of the 115V models. Selecting a high-heat operation is achieved by selecting an appropriate program.

On 230V models, the Glass Plus, Scientific, and User 2 Set programs operate at the higher temperature. When one of these programs is selected, the display window indicates the program chosen, as well as the term, “HI HEAT.” When the Rinse Only, Plastic, Glass, or User 1 Set program is selected, the display window indicates the program chosen, as well as the term, “LOW HEAT.”

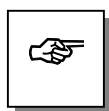

USE CARE WHEN SELECTING HIGH-HEAT PROGRAMS IF PLASTIC WARE IS BEING WASHED.

To start a wash cycle:

1. Close the washer door and energize the electronic control by sliding the door latch knob from the left to the right position to lock the latch.
2. Press the Select Program button until the desired program is shown on the display. To observe the details of the program, press the Shift Prog button. The display will then show the Wash 1 time, the Wash 2 time, the number of rinses, the total wash time, and the drying time.
3. If you need to alter the Wash 2 time, the number of rinses, or the drying time, press the appropriate button directly below the displayed parameter until the desired information is displayed.
4. If a pure water rinse is needed, press the corresponding button. If the purified water is feeding from a non-pressurized system, make certain there is adequate water in the reservoir (a minimum of 5 gallons or 18.9 liters).

If steam operation is needed, press the corresponding button. In this mode, the Glassware Washer will refill with fresh water after the completion of Wash 1. Both the sump and steam heaters will operate for 10 minutes to produce hot vapor to penetrate and soften dried residue, allowing detergent and hot water to work effectively.

5. On Mobile washers, turn the hot water on.
6. Press the Start button to begin the wash cycle.
7. Press the Shift Program button if you want the display to indicate details about what mode the washer is in and the time remaining.

Interrupting a Wash Cycle

To temporarily pause a wash cycle, simply unlatch the washer door. After the door is unlatched, wait 4 to 5 seconds before opening the door to prevent water from splashing out of the washer.

To resume the wash cycle, close and re-latch the washer door. The washer will pause to equalize temperatures and then the cycle will resume at the point it was interrupted.

The wash cycle can be terminated at any time by pressing the Start/Cancel button.

CHAPTER 5

MAINTAINING YOUR WASHER

Under normal operation, your Glassware Washer will require little routine maintenance to keep it functioning properly. Read this chapter to learn how to:

- safely clean the stainless steel interior
- maintain the water fill valve
- clean the overflow dome
- remove the top and side panels of your washer
- clean the filter screen

Maintaining the Stainless Steel Interior

The interior of your Glassware Washer is stainless steel.

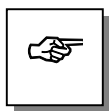

NEVER USE METAL SCOURING PADS ON THE STAINLESS STEEL INTERIOR. METAL SCOURING PADS CAN SCRATCH OR LEAVE METAL CHIPS THAT WILL RUST.

To maintain the appearance and quality of the stainless steel interior, perform the following tasks as needed:

- Wipe the outer edges on the inside door panel to remove particles and residue that occur during loading.
- Use a sponge sprinkled with non-abrasive stainless steel cleaner to gently wipe the washer tank and door to remove surface discoloration caused by exposure to halogenated compounds or steel parts. In some cases, the finish may be slightly dulled by this action.

If your water has a high mineral content, film or spots may develop on the washer interior. If the procedures listed above do not eliminate the film or spots, you may need to follow the steps below to run your washer through a special cycle.

To remove film or spots from the washer interior:

1. Remove all glassware from the washer.
2. Choose the Glass Program, Steam OFF, Pure Rinse OFF, and set the drying time to zero.
3. After the first fill is complete, open the washer and carefully pour one cup of bleach into the bottom of the tank.
4. Close the washer door and allow the unit to wash and drain (approximately six minutes).
5. When the washer fills the second time, open the washer and add two cups of 4-8% acetic acid (or white vinegar) to the bottom of the tank.
6. Close the washer door and allow the unit to wash and drain without further interruption.

Maintaining the Air Gap

If you employed an air gap during the installation of your washer, you need to clean the air gap at least once a month. The air gap is not part of the washer; therefore, it is not covered by the washer warranty. The air gap protects the washer against water backing up in the event of a clogged drain.

Check the air gap for build-up any time your washer is not draining well.

Most types of air gaps are easy to clean. Simply follow the manufacturer's directions for maintaining your air gap.

Maintaining the Water Fill Valve

The filter screen of the water fill valve, illustrated in Figure 5-1 below, may require periodic cleaning to remove trapped particles. A low water fill occurs if the blockage is not removed.

Figure 5-1

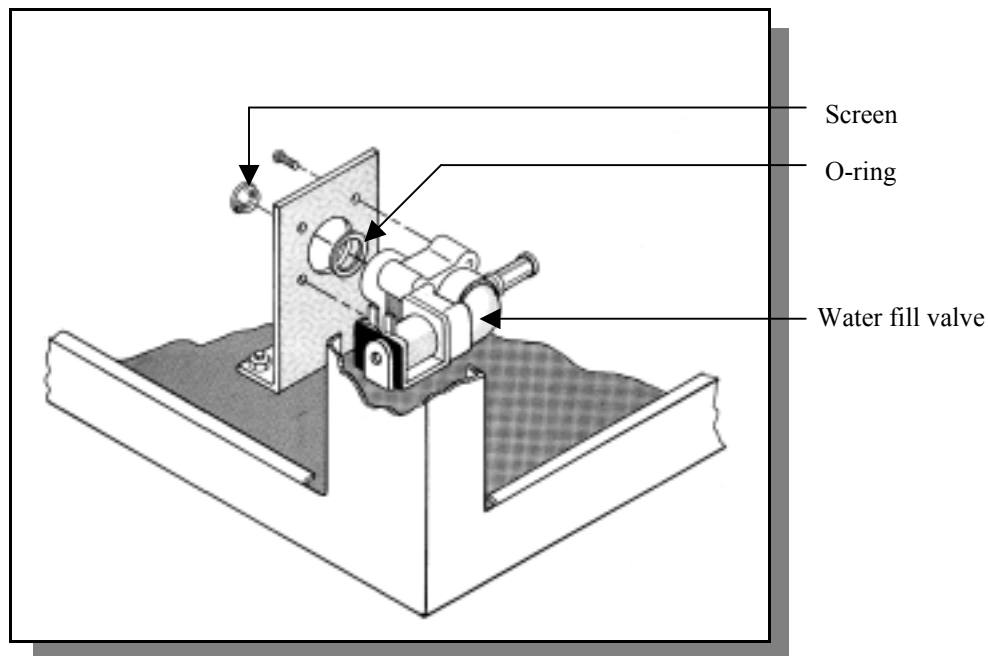

Refer to Figure 3-7 in Chapter 3: Getting Started for an illustration showing how to remove the lower panel of your washer.

To clean the water fill valve:

1. Turn off the water and electricity to the washer. Unplug the Mobile model; turn off the circuit breaker that services the Undercounter or Freestanding model.
2. Remove the two screws at the bottom of the lower panel of your washer.
3. Remove the panel by lifting slightly and pulling out.
4. Place a pan under the fill valve.
5. Remove the four screws from the valve plate and separate the valve from the inlet connection.
6. Drain the water into the pan.
7. Remove the valve filter screen and clean it under running water.
8. Replace the screen and reassemble the valve connection. Be certain the O-ring gasket, identified in Figure 5-1, is positioned in the groove in the fill valve body.
9. Tighten all screws; replace the lower panel, restore electrical power to the washer, and turn on the water.
10. Check for leaks and adjust as needed. Replace the lower panel.

Maintaining the Overflow Dome

The overflow dome is located inside the washer in the front left corner, as illustrated in Figure 5-2. The dome may require periodic cleaning to remove residue from inside the dome.

Figure 5-2

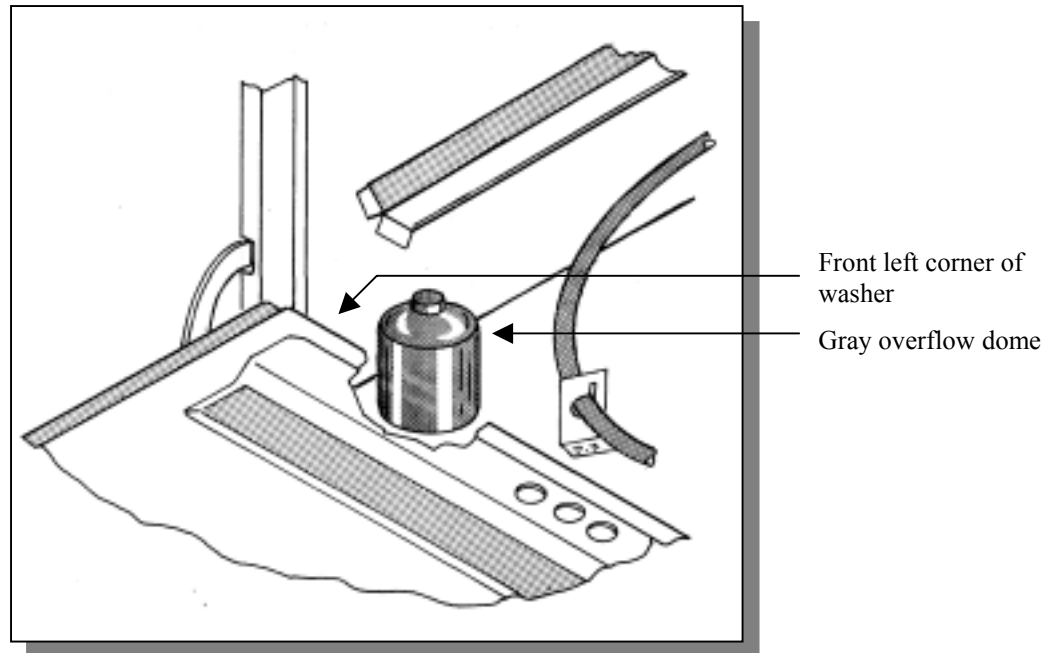

To clean the overflow dome:

1. Turn off electrical power to the Glassware Washer.
2. Remove the two screws at the bottom of the lower panel of your washer.
3. Remove the panel by lifting slightly and pulling out.
4. Locate the gray dome in the front left corner of the washer.
5. Remove the nut from the bottom of the dome stem by holding the dome with one hand and loosening the nut with the other.
6. Lift the dome off and clean it with warm soapy water.
7. Clean the spot inside the washer where the dome was positioned.
8. Replace the dome and tighten the nut until the plastic stem is flush with the surface of the nut.
9. Replace the lower panel.

Figure 3-7 in Chapter 3: Getting Started illustrates how to remove the lower panel of your washer.

Replacing the Washer Light Bulb

If your Glassware Washer is equipped with a window, you will need to periodically replace the 25-watt washer light bulb. Refer to Figure 5-3 and follow the instructions below to replace the washer light bulb.

To replace the washer light bulb:

1. Turn off electrical power to the Glassware Washer.
2. Remove the outer door panel by removing the two screws located on each side of the washer, identified in Figure 5-3.
3. Remove the bulb by pressing in on the bulb and rotating the bulb counterclockwise.
4. Insert the new bulb and rotate clockwise into place, as shown in Figure 5-3.
5. Replace the outer door panel.

Figure 5-3

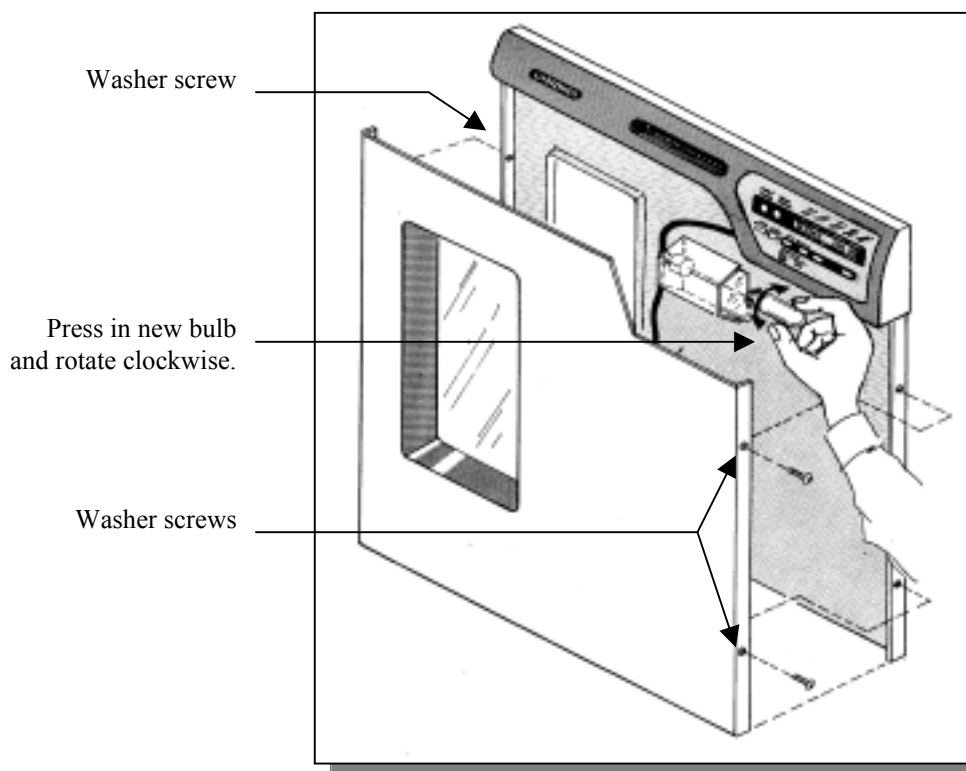

Removing the Washer Top, Back, and Side Panels

There may be times when you need to remove the washer top, back, and side panels to clean, maintain, or repair your washer. Refer to Figure 5-4 and follow the instructions below to remove the top, back, and side panels of your washer.

To remove the washer top, back, and side panels:

1. Turn off electrical power to the Glassware Washer.
2. Remove all of the screws from the back panel of the washer and remove the back panel.
3. Remove the two screws in the front of the washer that attach the washer top to the sides.
4. Remove the two screws in the back of the washer that attach the washer top to the sides.
5. Slide the washer top toward the rear. Lift the washer top and remove.
6. Remove the two screws from each side of the washer at the front edge.
7. Remove one screw at the rear of the washer.
8. Remove the side panels.

Figure 5-4

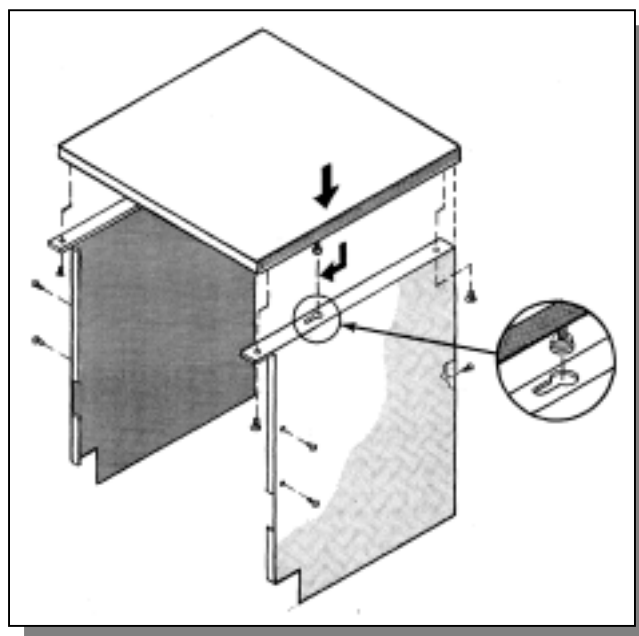

Remove four screws that attach the top to the sides. Then, slide the washer top toward the rear of the washer and lift to remove.

Cleaning the Sump Filter Screen

If debris accumulates on the filter screen that is located in the washer sump, you can remove and clean the screen. To clean the sump filter screen, refer to Figure 5-5 and follow the instructions below.

To clean the sump filter screen:

1. Open the washer door and remove the bottom rack.
2. If you have a SteamScrubber, remove the upper wash arm. Depress the button on the wash arm tower and lift the upper portion of the tower to remove the wash arm. If you have a FlaskScubber, remove the plastic clamp and rubber diaphragm from the wash tower, as illustrated in Figure 5-5.
3. Lift and rotate the lower wash arm.
4. Remove the screw and clip at the rear of the filter screen.
5. Carefully lift the screen, using care not to drop debris into the pump.

Refer to Figure 4-1 in Chapter 4: Using Your Washer for an illustration of the SteamScrubber wash arm and tower.

Figure 5-5

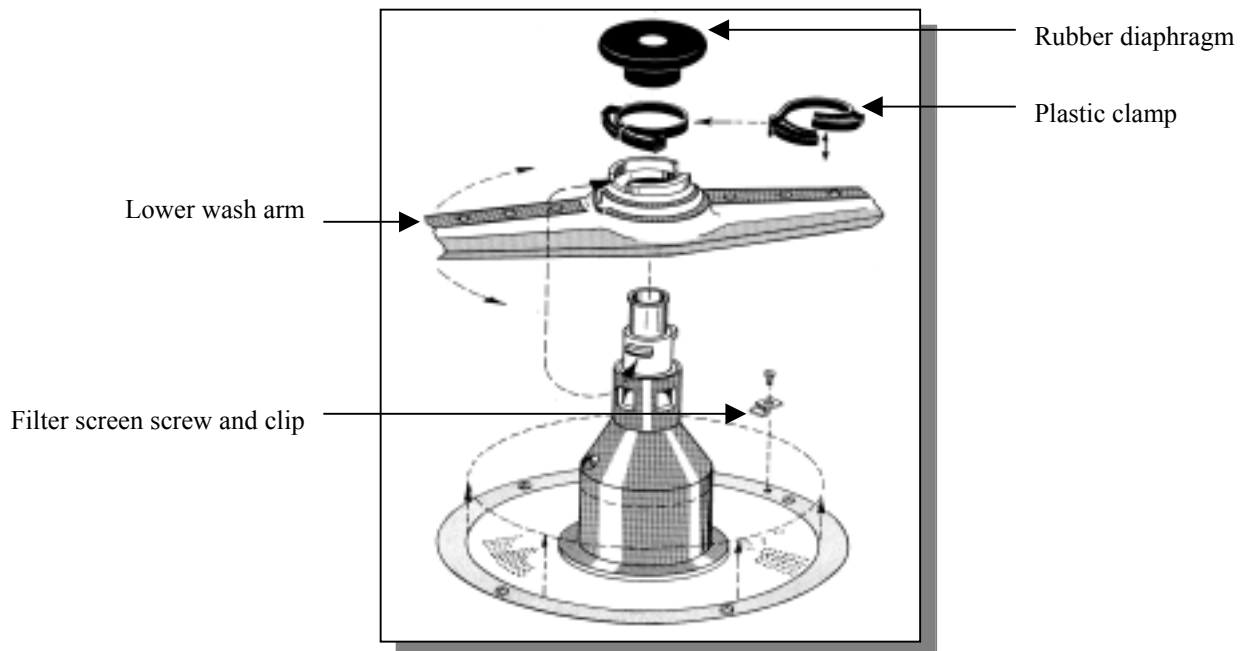

CHAPTER 6

MODIFYING YOUR

WASHER

The configuration of your washer may need to be changed to accommodate your needs. For example, you may want to disconnect the purified water pump, install pipet inserts, or install an optional top rack. Read this chapter to learn how to:

- disconnect the purified water pump from your washer
- install pipet inserts in a FlaskScrubber washer
- install an upper rack in a FlaskScrubber washer
- install inserts into FlaskScrubber spindle racks
- install the upper spindle rack

Disconnecting the Purified Water Pump

If you have no need for the purified water pump on your washer, you may choose to disconnect it. Refer to Figure 6-1 and follow the steps detailed below to disconnect the purified water pump.

*Refer to Figure 3-7
in Chapter 3:
Getting Started for
help in removing
the lower panel.*

To disconnect the purified water pump:

1. Disconnect the washer from its electrical source.
2. Remove the two screws at the bottom of the lower panel of your washer.
3. Remove the panel by lifting slightly and pulling out.
4. Remove the red wire (circuit 30) from the N.O. terminal of the deionized pump relay.

Figure 6-1

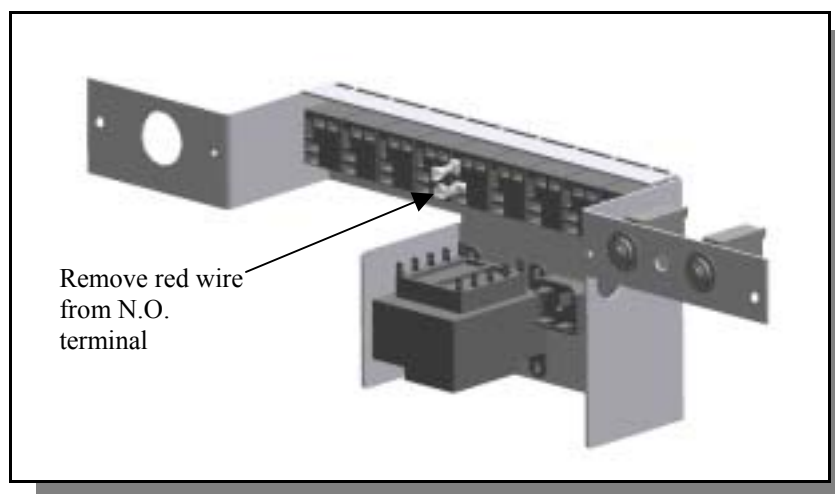

FlaskScrubber Options

If you purchased a FlaskScrubber Glassware Washer, you can modify the configuration of your washer to better suit your needs, if desired. Optional accessories include two Pipet Inserts, Adjustable Height Upper Rack, and an Upper Spindle Rack. The Pipet Inserts are easily installed in place of one or more spindles in the washer and are designed to accommodate 1 ml to 50 ml pipets.

Installing Pipet Inserts in a FlaskScrubber

Two sizes of Pipet Inserts are available. The 8-place Pipet Insert, shown in Figure 6-2 accommodates 1 ml to 10 ml pipets. Multiple Pipet Inserts may be installed, if desired. Refer to Figure 6-2 and follow the instructions below to install an 8-place Pipet Insert.

To install an 8-place Pipet Insert:

1. Insert a screwdriver into the top of any $\frac{1}{4}$ " spindle and turn counterclockwise to remove the spindle. Small spindles may be removed by hand.
2. In the position previously occupied by the spindle, thread into place the short spindle you received with the Pipet Insert.
3. Push the Pipet Insert over the short spindle.

Figure 6-2

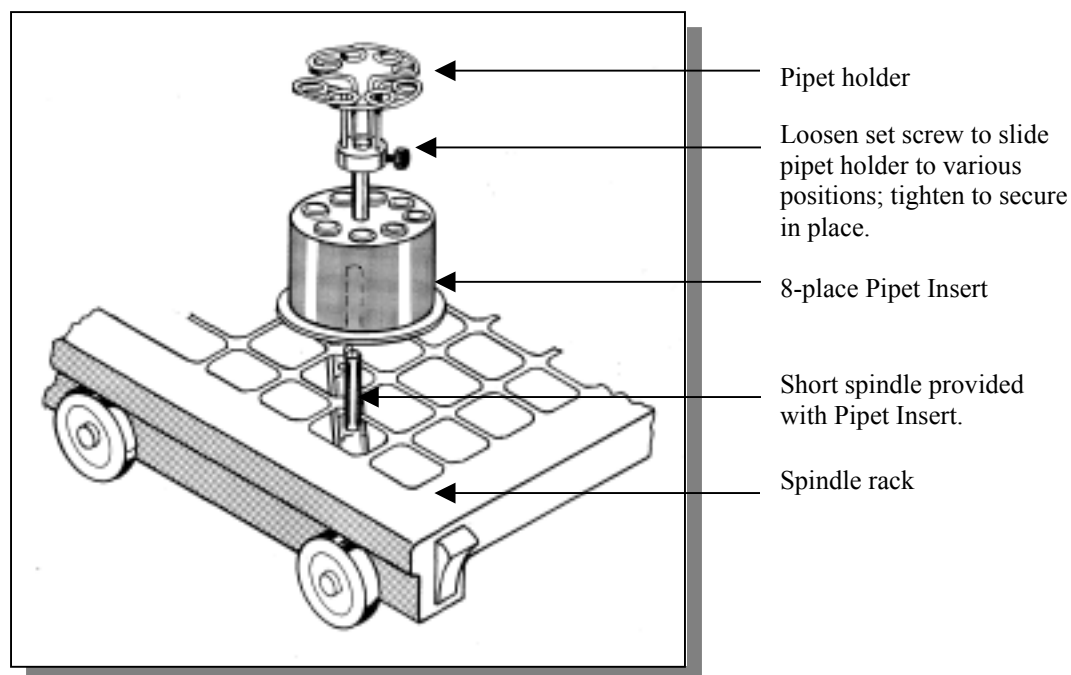

The 14-place Pipet Insert, shown in Figure 6-3, accommodates 1 ml to 50 ml pipets. Two of these inserts may be installed, if desired. Refer to Figure 6-3 and follow the instructions below to install a 14-place Pipet Insert.

To install a 14-place Pipet Insert:

1. Use a screwdriver to remove the three spindles on either the right side or left side of the spindle rack. Remove others if necessary.
2. Replace the front and back spindles with the two short spindles that you received with the Pipet Insert.
3. Replace all other spindles with one of the plastic plugs that you received with your washer.
4. With the support facing the center of the spindle rack, slide the Pipet Insert over the spindles until it completely seats.
5. Pipets can be pushed into the 14 receptacles and rest on the support.

Figure 6-3

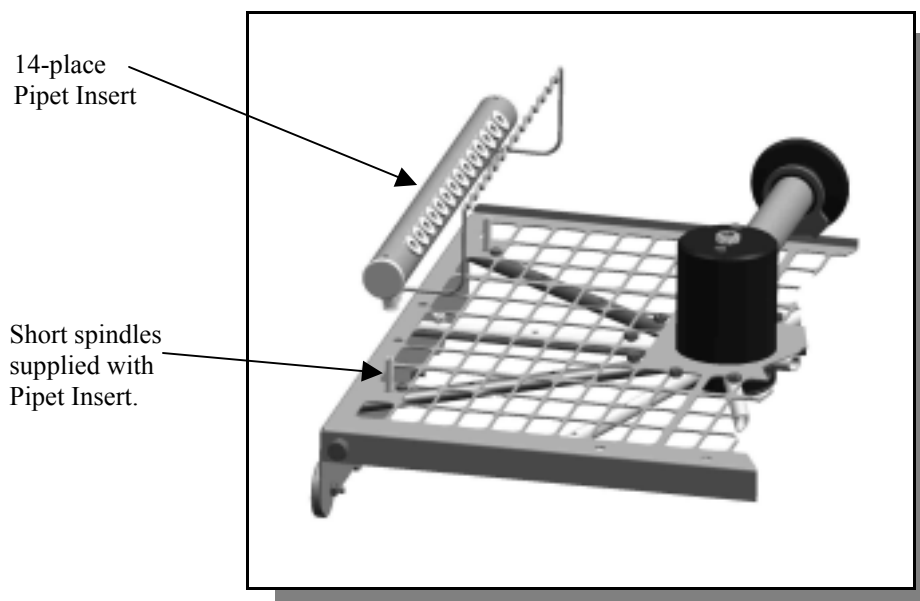

Installing the Optional Adjustable-Height Upper Rack

An optional top rack, shown in Figure 6-6, is available to increase the capacity of the FlaskScrubber to handle wide-mouth glassware, including beakers. To install the optional top rack, refer to Figures 6-4 and 6-5 and follow the instructions below.

To install the optional upper rack:

1. Remove all of the parts from the carton. See Appendix D for a list of parts shipped.
2. Use a 3/8" hex wrench to remove the black plug in the center of the spindle rack and replace with the 1/2" to 3/8" bushing.
3. If the rack is to be located in the upper position, thread in the hub-adapter assembly that you received with the rack (see Figure 6-4). If the rack is to be located in the lower position, (see Figure 6-4A), remove the nozzle from the hub-adapter assembly and thread it into the bushing.

Figure 6-4

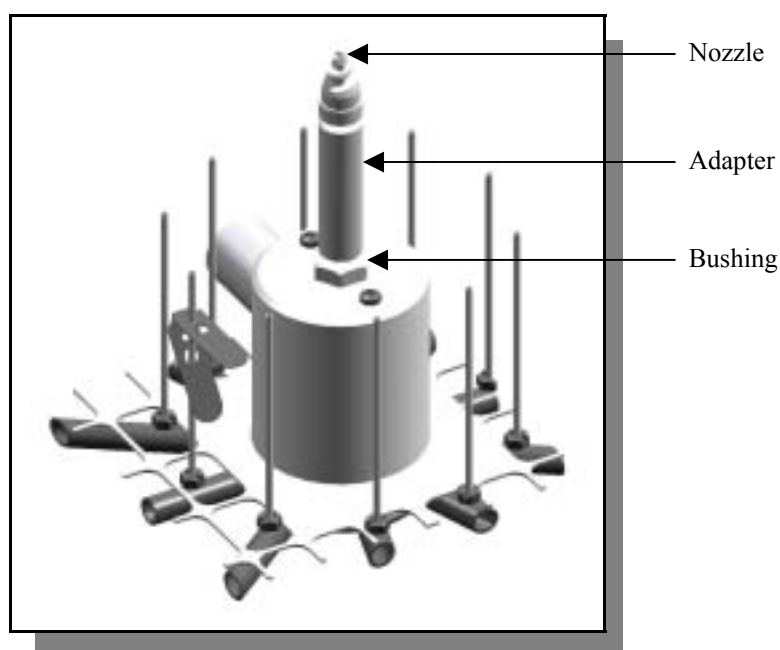
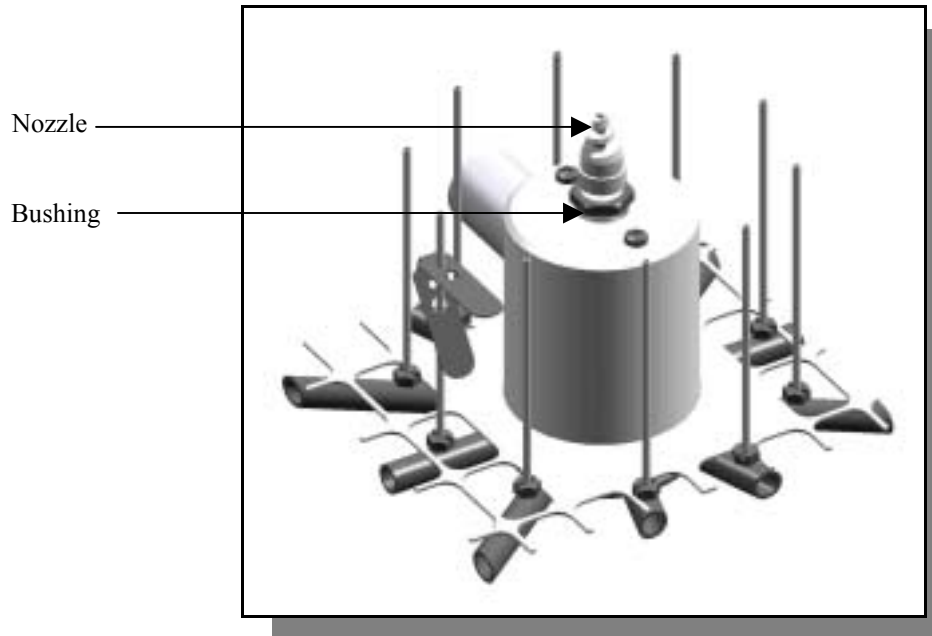

Figure 6-4A



Install the rails with the slots on the bottom.

4. Install the left and right rails by tilting the top of the rails between the rollers on the sides of the washer tank and push the bottoms of the rails into place, as illustrated in Figure 6-5. Install both rails at the same height.
5. Install the frame of the top rack by inserting the rollers on the rack into the rails on the sides of the washer.
6. Push in the frame of the top rack until its rollers are secure within the rails. Then, install the two basket inserts, as illustrated in Figure 6-6. By rotating the baskets 180°, they may be positioned higher or lower.
7. Install the two gray rubber bumpers on the ends of the rails, as shown in Figure 6-5, to secure the rack rollers.

Figure 6-5

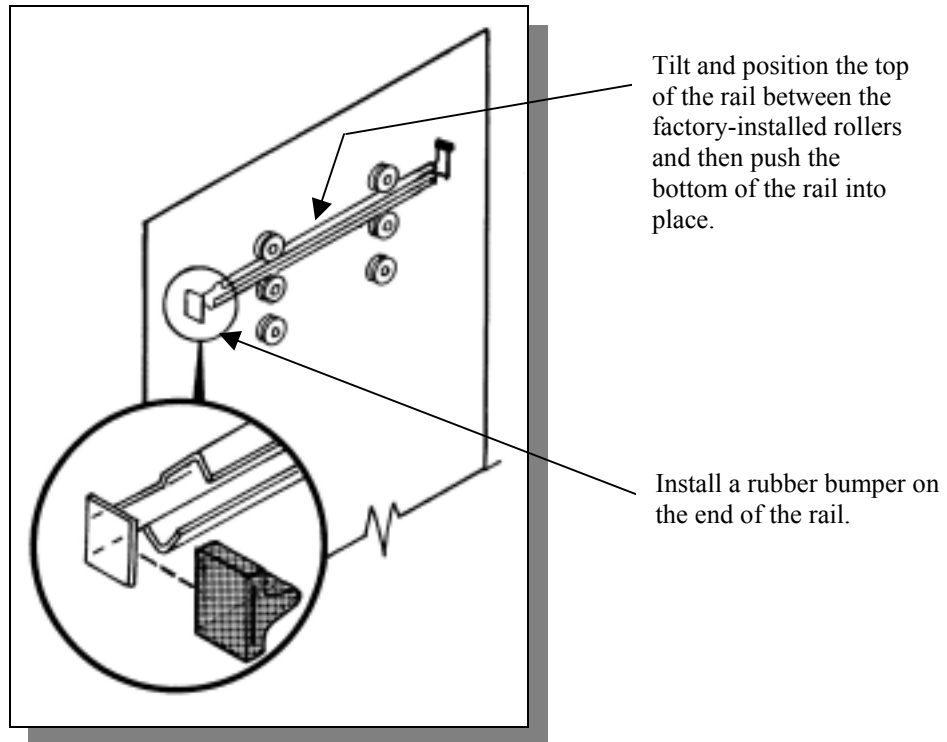
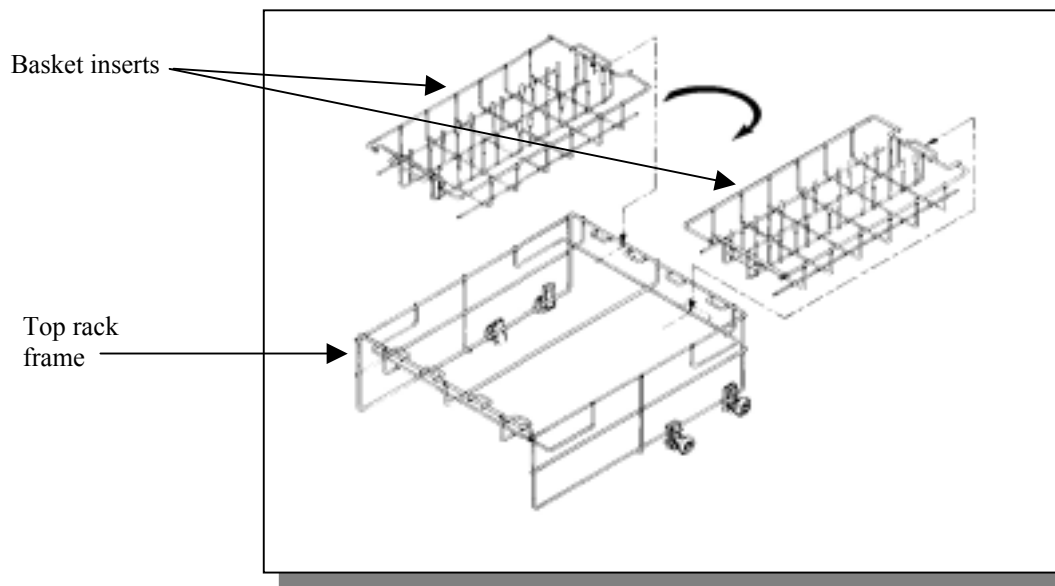

Figure 6-6



Installing the Optional Upper Spindle Rack

The Upper Spindle Rack expands the capability of the FlaskScrubber by providing 24 additional spindles for washing narrow-neck glassware. The rack may be customized by removing spindles or by installing Multi-Pin Inserts which hold beakers or other wide mouth glassware.

To install the optional Upper Spindle Rack

- A. Modifying the existing lower spindle rack.
1. Using a 3/8" hex wrench, remove the plug in the center of the hub.
 2. Install the upper supply tube assembly into the center of the hub. See Figure 6-7.
 3. Keep the plug so that it can replace the upper supply tube when it is desired to wash with the upper spindle rack removed.

Figure 6-7

Remove plug and
install upper supply
tube into the hub

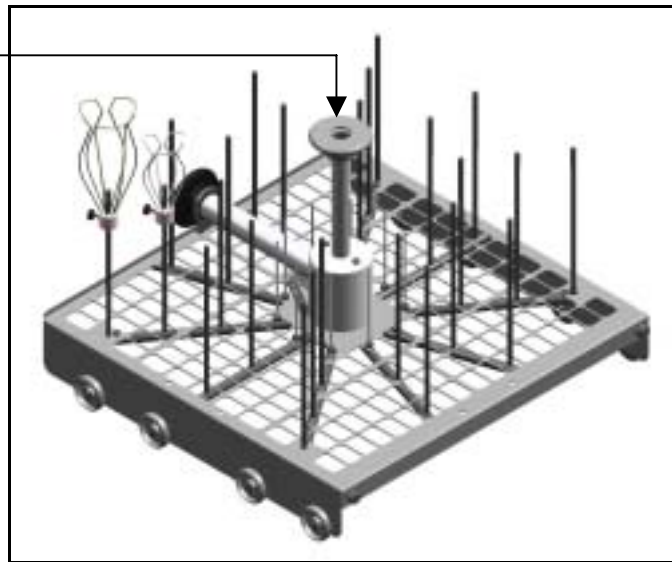

B. Install the upper rails and the upper spindle rack. See Figure 6-8.

1. Install the rear rubber bumpers to the ends of the rails.
2. Install the left and right rails by tilting the top of the rails between the rollers on the side of the washer tank and push the bottoms of the rails into place. Rails must be positioned between the top sets of rollers as shown in Figure 6-8. (Upper Spindle Rack cannot be positioned in the lower set of rollers.)

Figure 6-8

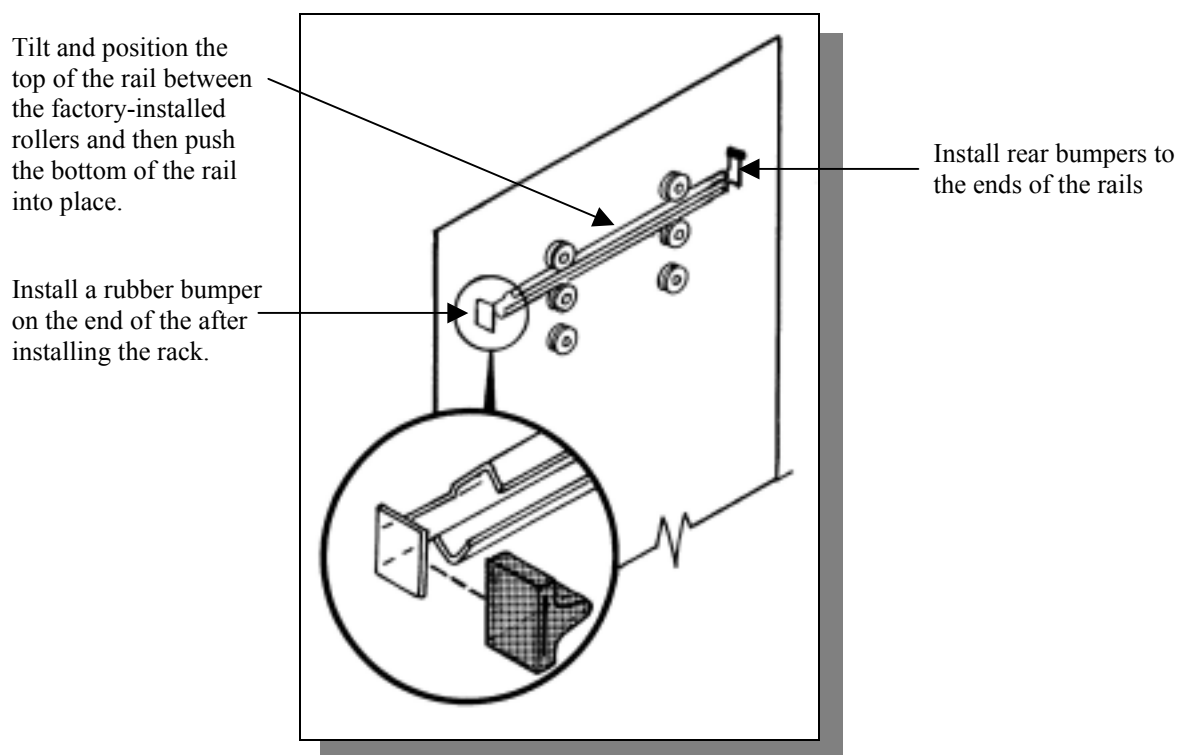

3. Install the frame of the Upper Spindle Rack by inserting the rollers on the rack into the rails on each side of the washer.
4. Push the Upper Spindle Rack into the washer until its rollers are secure within the rails.
5. Install the two gray rubber bumpers on the ends of the rails, as shown to secure the rack rollers.

C. Adjust the rubber diaphragm

The rubber diaphragm, that is on the upper supply tube assembly installed in Step A, should almost touch the lower portion of the hub in the upper spindle rack when both racks are inside the washer. The diaphragm should not interfere with the hub when either rack is pulled out.

1. Loosen the clamp at the bottom of the diaphragm (if necessary) by pressing the clamping surfaces sideways.
2. Raise or lower the diaphragm as needed.
3. Reinstall the clamp securely by squeezing the two halves together.

When the Upper Spindle Rack is in place, it limits the height of the glassware that can be washed. If very tall glassware or long pipets are to be washed, remove the Upper Spindle Rack and replace the plug in the center of the hub on the lower spindle rack.

Installing Insert into the Spindle Rack

A Multi-Pin insert is available that can be placed directly on the FlaskScrubber spindle rack that can hold beakers or wide mouth glassware. The insert can be positioned either on the left side, right side or front.

To install an insert

1. Remove all glassware, spring retainers and glassware holders.
2. Lower the insert down over the spindle making sure that the two alignment pins enter the two holes in the rack. If necessary, spindles may be removed using a screwdriver in the slot on the top of the spindles. Be sure to replace any removed spindle with a plug supplied with the washer.

Figure 6-9

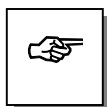
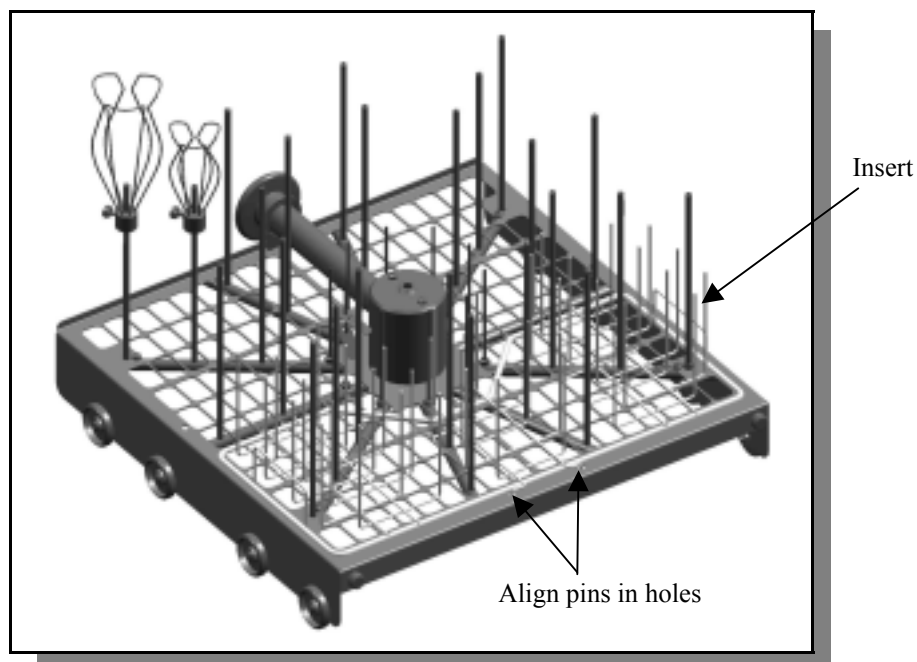

IF THE MULTI-PIN INSERT IS INSTALLED ON THE BOTTOM RACK AND THE OPTIONAL UPPER RACK IS USED, DO NOT HEAVILY LOAD THE MULTI-PIN INSERT WITH WIDE MOUTH GLASSWARE. THIS MAY RESTRICT WATER FLOW FROM THE LOWER DISTRIBUTION ARM TO THE GLASSWARE IN THE UPPER RACK.

CHAPTER 7

TROUBLESHOOTING

Refer to the following table if your Glassware Washer fails to operate properly. If the suggested corrective actions do not solve your problem, contact Labconco for additional assistance.

PROBLEM	CAUSE	CORRECTIVE ACTION
Detergent cup fails to open	Malfunction of cup	Replace cup.
	Malfunction of relay	Check electrical continuity or replace relay.
	Glassware interfering with cup door	Move glassware.
Noises during operation	Glassware rattling	Load glassware properly. Do not allow glassware to touch.
	Door panel vibrating	Tighten panel screws.
	Wash arms hitting	Check glassware loading. Check for damaged wash arm bushing.
	Water inlet line makes occasional hammering sound	Check with plumber.
	Purified water pump is activated	No corrective action needed. This is normal for about 2 minutes.

PROBLEM	CAUSE	CORRECTIVE ACTION
Door drops too far (below door stop)	Bent door hinge	Replace door hinge.
Poor drying	Water is not hot enough	Check inlet water temperature (minimum 120° F) at the washer.
	Flask, beaker, or labware with concave bottoms not loaded correctly	Tilt these articles when loading so that water drains off.
	Recondensation	If clean labware is left in the washer, recondensation may occur. Open latch after completion of cycle to allow moisture-laden air to escape.
	Heater(s) disconnected or malfunctioned	Reconnect or replace heater.
	Blower disconnected or malfunctioned	Reconnect or replace blower.
Poor washing results	Water is not hot enough	Check inlet water temperature. Must be at least 120°F. Recommended temperature is 150°F.
	Improper loading	Check washer loading instructions in <i>Chapter 4</i> in this manual.
	Detergent too old or amount wrong	Replace detergent or change quantity used.
	Detergent caked in cup	Clean cup. Replace with fresh detergent. Check water inlet temperature. Must be at least 120°F.
	Insufficient wash time	Increase wash cycle time.
	Insufficient water	Check to be sure the water shut-off valve is fully open. Check to be sure the water pressure is between 20 and 120 psi at a flow rate of 1.25 gallons per minute.
	Blocked fill valve screen	Check screen in fill valve.

PROBLEM	CAUSE	CORRECTIVE ACTION
Not draining properly	Clogged filter	Clean sump filter.
	Drain line clogged or kinked	Disconnect drain line and clean or remove kink.
Purified water does not fill	Crimp in supply hose	Refer to installation instructions for proper purified water piping installation.
	Blown fuse	Replace fuse.
	Motor wires disconnected	Reconnect wires.
	Drain hose not elevated above water level.	Elevate drain hose per installation instructions.
Racks binding or out of place	Roller missing	Replace roller.
	Roller binding	Adjust or replace rollers and rails.
	Upper rack rail bent	Replace rail.
Tank and inner door have surface rust	Collects normally	Clean with stainless steel cleaner and soft cloth.
	Glassware is contaminated with mineral acids.	Pre-rinse glassware.
Washer does not run	No power to washer	Check fuse or circuit breaker.
	Door latch is open	Latch washer door by pushing door in.
Washer door opens and closes badly	Cabinet opening is not square	Correct opening with leveling feet.
	Door hitting counter-top mounting screws	Adjust mounting screws.
Washer leaks	Washer is not level	Adjust leveling feet.
	Door not sealing	Adjust door latch.
	Tank gasket loose	Check gasket and correct.
	Split fill tube	Replace fill tube.

PROBLEM	CAUSE	CORRECTIVE ACTION
Washer leaks (cont.)	Fill tube out of trap	Reinstall fill tube.
	Loose connection at fill valve	Check fill valve and correct.
	Improper detergent	Use non-foaming detergent. Use only proper amount of detergent.
	Obstruction in drain line	Remove obstruction.
Washer leaks around door seal	Improper installation	Check cabinet opening to see if it is aligned properly with the door. Washer must be level. Adjust feet to level unit.
	Unit not level	Adjust feet to level unit.
	Door opened during operation	Allow 4-5 seconds before opening door after unlatching.
Washer will not drain	Clogged drain	Clean out drain.
	Blockage of air gap	Clean the air gap by lifting the cover, unscrewing the cap, and removing any accumulated material. See <i>Chapter 5</i> .
	Kink in drain hose	Check for a kink in the drain hose.
	Filter blocked	Check filter in washer and clean as needed.
Washer will not fill	Improper drain installation	Refer to installation instructions in <i>Chapter 3</i> .
	Fill valve clogged	Clean fill valve.
	Drain hose not elevated above water level	Elevate drain hose per instructions in <i>Chapter 3</i> .
Selection buttons on control panel inoperable or controls malfunction	Microprocessor memory error	Perform "Factory Reset". Open latch on door. Press "Pure" button and simultaneously close door latch. Release "Pure" button and display will read "Factory Reset". Press "Select Program" button to choose wash cycle.

APPENDIX A

FLASKSCRUBBER AND STEAMSCRUBBER COMPONENTS

The following components are available for your Glassware Washer. The FlaskScrubber components are listed first, then the SteamScrubber components.

FLASKSCRUBBER COMPONENTS

Item	Part # 115V	Part # 230V	Quantity	Description
1	44447-00	44447-00	1	Upper Basket Rail (R.H.)
1A	44451-00	44451-00	1	Upper Basket Rail (L.H.)
2	44352-00	44352-00	1	Overflow Dome
3	44981-00	44981-00	1	Detergent Cup
4	45038-03	45038-04	1	Controller Assembly
4A	45037-00	45037-00	1	Display Assembly
5	14804-01	14804-01	1	Drain/Water Supply Hose (Mobile) (Not Shown)
5A	44861-01	44861-01	1	Drain Hose (Undercounter, Freestanding) (Not Shown)
6	44105-00	44688-00	1	Motor Start Relay
7	44114-00	44692-00	1	Hot Water Inlet Valve (Mobile)
7A	13613-00	13613-01	1	Hot Water Inlet Valve (Undercounter, Freestanding)
8	44114-00	44692-00	1	Purified Water Inlet Valve
9	45298-01	45298-01	1	Thermostat, Sump 180°F
10	44863-00	44863-00	1	Fill Trap
11	45278-00	45278-00	1	Vacuum Blower (FlaskScrubbers)
12	45261-00	45262-00	1	Sump Heater
13	44871-00	44871-01	1	Pump Assembly
14	45298-00	45298-00	1	Thermostat, Sump – 140°F
15	45279-00	45279-00	1	Purified Water Pump
16	44606-00	44606-00	1	Vacuum Duct Assembly
17	45297-00	45297-00	1	Thermostat, Back (230V models require 2) (Not Shown)
18	45163-00	45178-00	1	Power Cord (Mobile)
19	45094-00	45094-01	1	Bulb - 25T8DC 120 (115V), 25T8DC 230 (230V) (Not Shown)
20	13272-03	13272-03	1	Breaker, Circuit
20A	13272-07	13272-07	2 (230V) 1 (115V)	Breaker, Circuit (Mobile)

Figure A-1

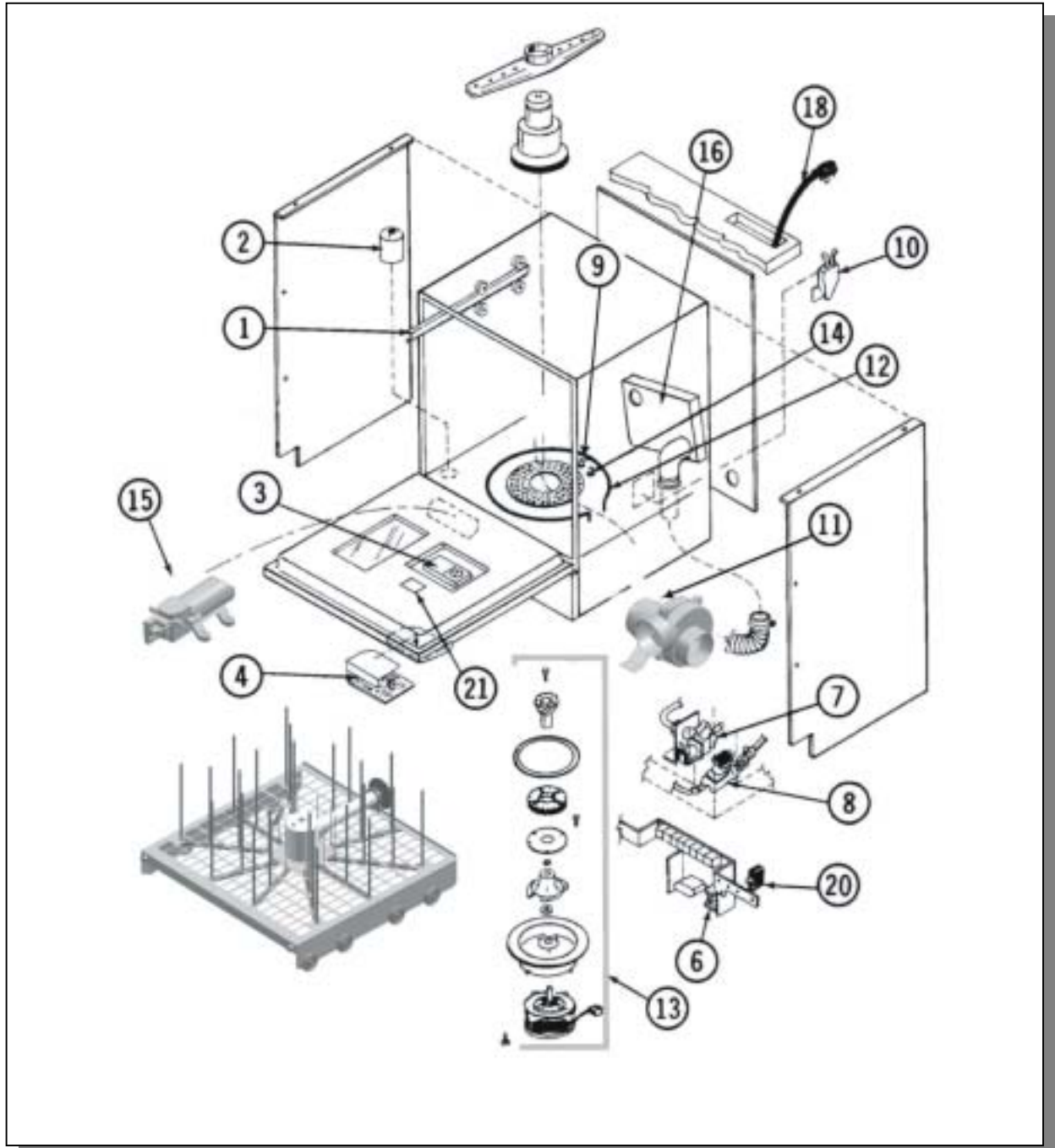

STEAMSCRUBBER COMPONENTS

Item	Part # 115V	Part # 230V	Quantity	Description
1	44447-00	44447-00	1	Upper Basket Rail (R.H.)
1A	44451-00	44451-00	1	Upper Basket Rail (L.H.)
2	44352-00	44352-00	1	Overflow Dome
3	44981-00	44981-00	1	Detergent Cup
4	45038-03	45038-04	1	Controller Assembly
4A	45037-00	45037-00	1	Display Assembly
5	14804-01	14804-01	1	Drain/Water Supply Hose (Mobile) (Not Shown)
5A	44861-01	44861-01	1	Drain Hose (Undercounter, Freestanding) (Not Shown)
6	44105-00	44688-00	1	Motor Start Relay
7	44114-00	44692-00	1	Hot Water Inlet Valve (Mobile)
7A	13613-00	13613-01	1	Hot Water Inlet Valve (Undercounter, Freestanding)
8	44114-00	44692-00	1	Purified Water Inlet Valve
9	45298-01	45298-01	1	Thermostat, Sump 180°F
10	44863-00	44863-00	1	Fill Trap
11	45254-00	45254-01	1	Blower
12	45261-00	45262-00	1	Sump Heater
13	44871-00	44871-01	1	Pump Assembly
14	45298-00	45298-00	1	Thermostat, Sump – 140°F
15	45297-00	45297-00	1	Thermostat, Back (Not Shown)
16	45279-00	45279-00	1	Purified Water Pump
17	44363-00	44363-00	1	Blower Shroud Assembly
18	45163-00	45178-00	1	Power Cord (Mobile)
19	45094-00	45094-01	1	Bulb – 25T8DC 120 (115V), 25T8DC 230 (230V) (Not Shown)
20	13272-07	13272-07	2 (230V) 1 (115V)	Breaker, Circuit (Mobile)
20A	13272-03	13272-03	1	Breaker, Circuit

Figure A-2

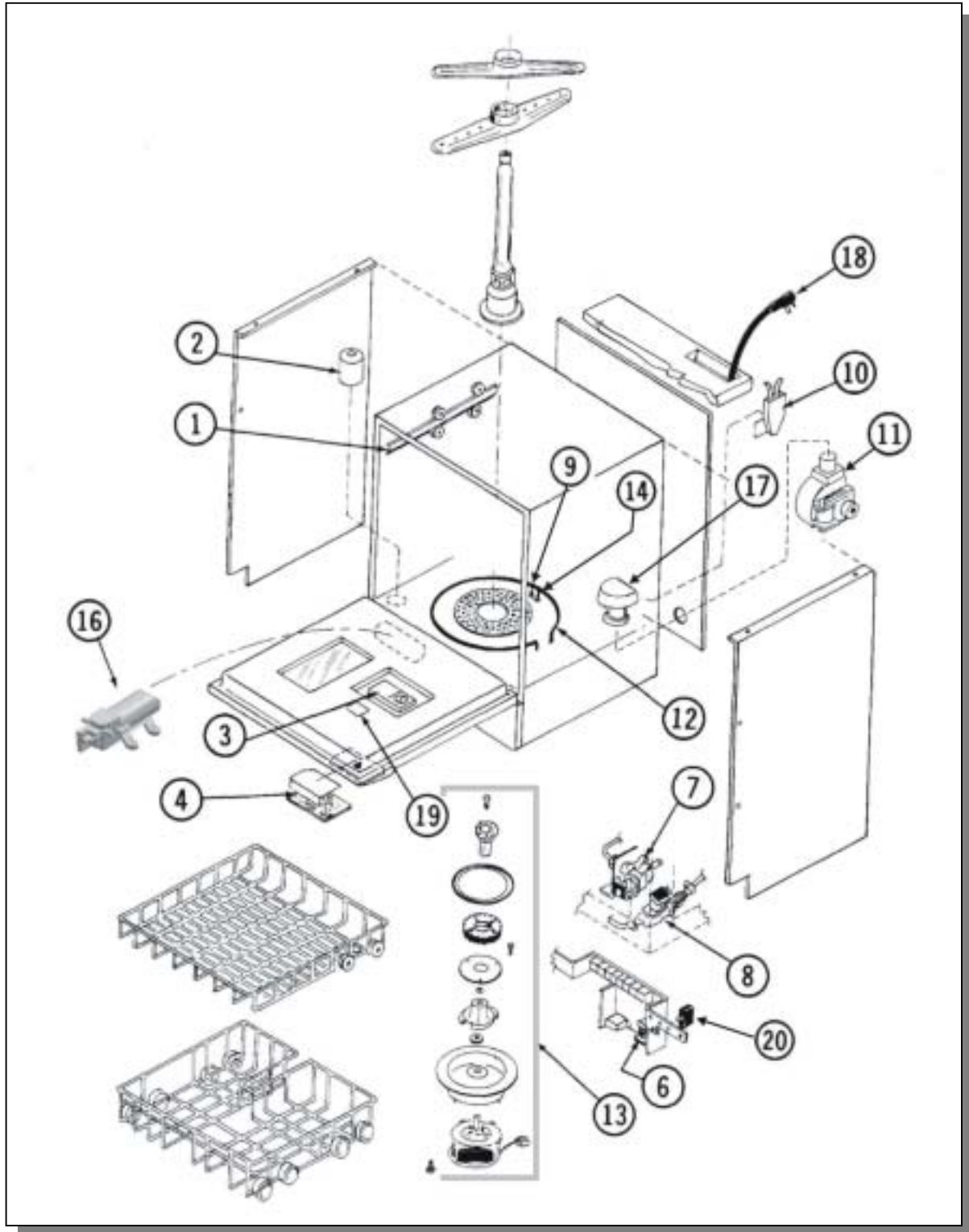

APPENDIX B

GLASSWARE WASHER DIMENSIONS

Freestanding Washer

English: Inch

Figure B-1

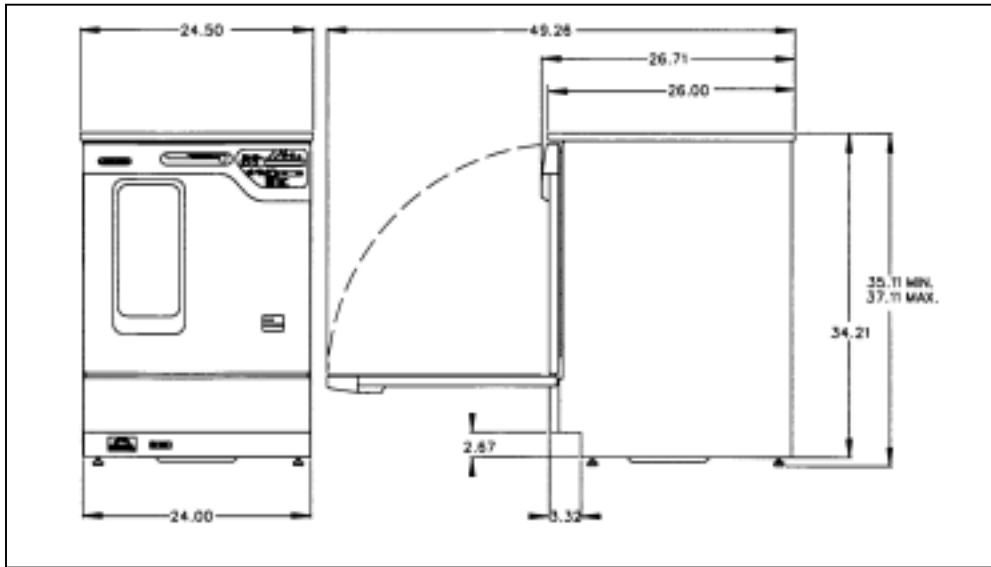

Metric: cm

Figure B-2

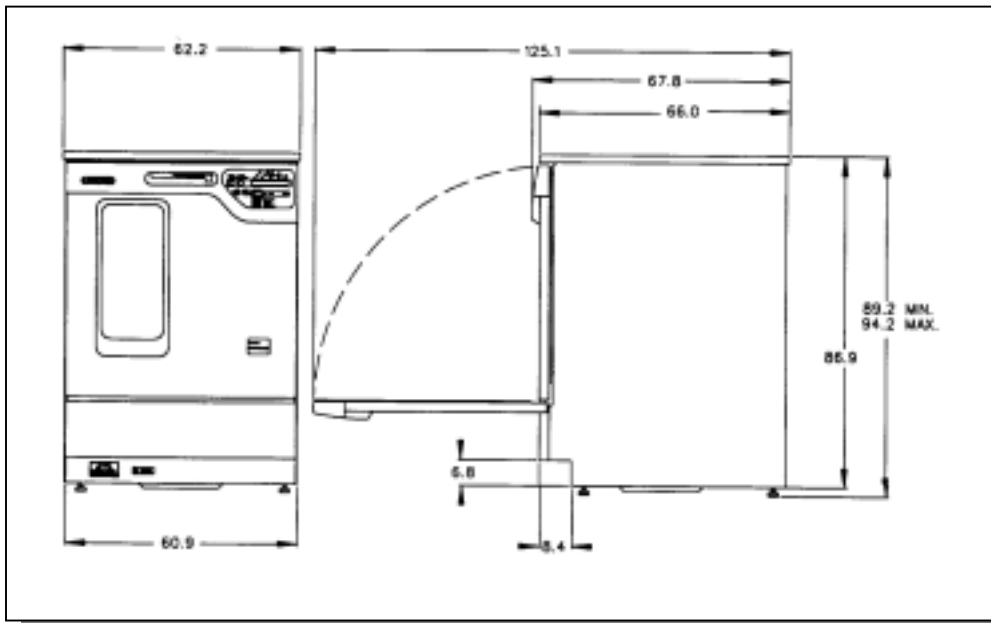

Mobile Washer

English: Inch

Figure B-3

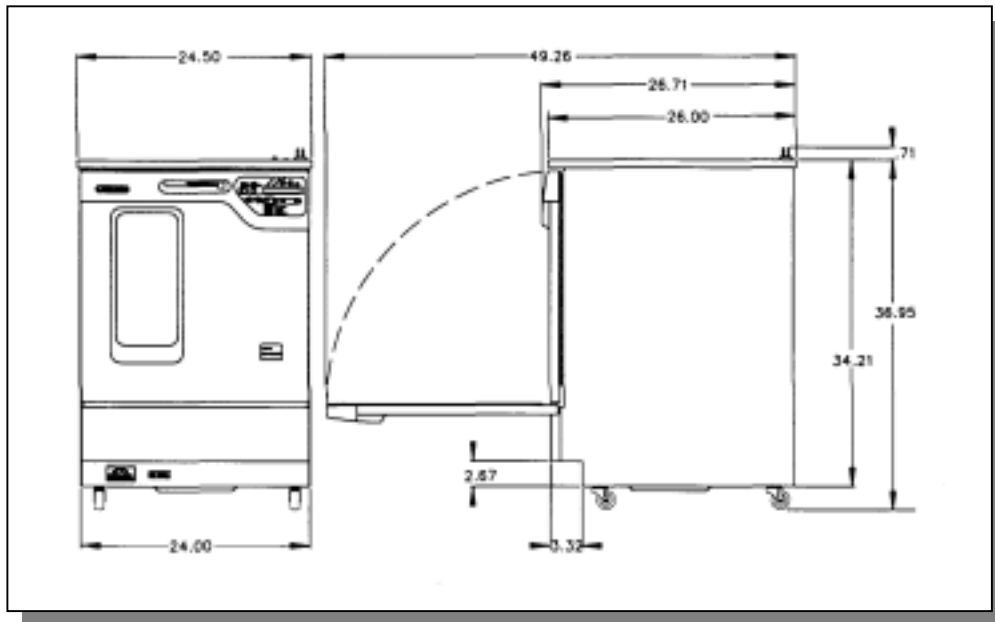

Metric: cm

Figure B-4

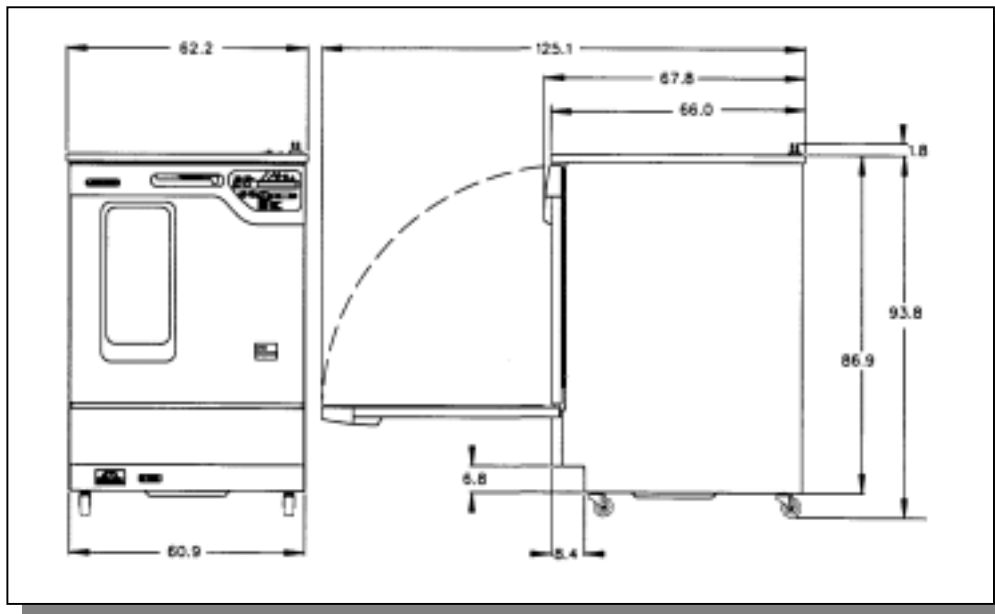

Undercounter Washer

English: Inch

Figure B-5

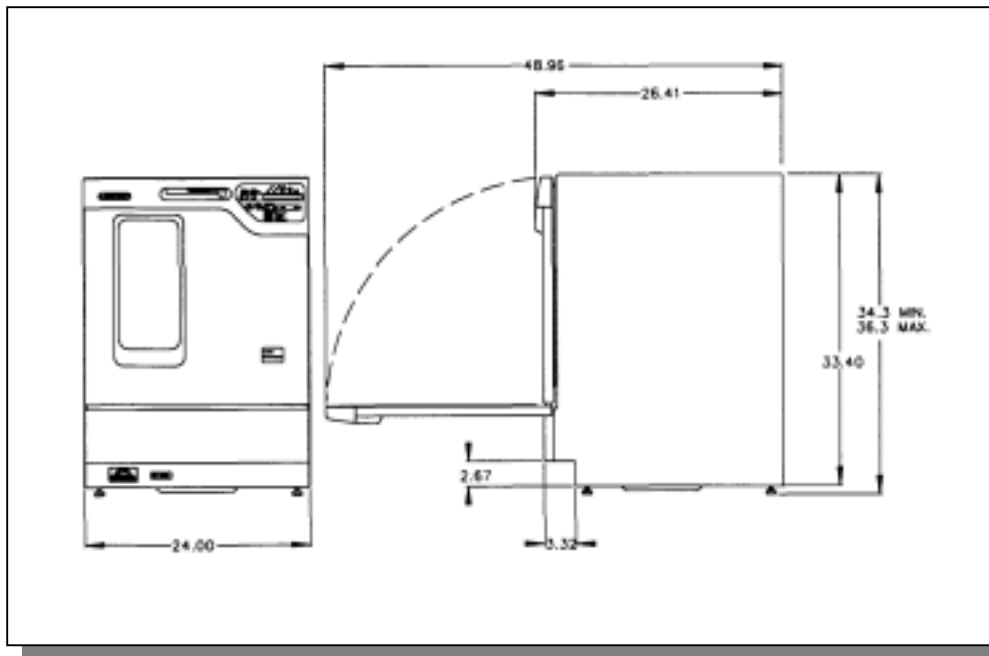

Metric: cm

Figure B-6

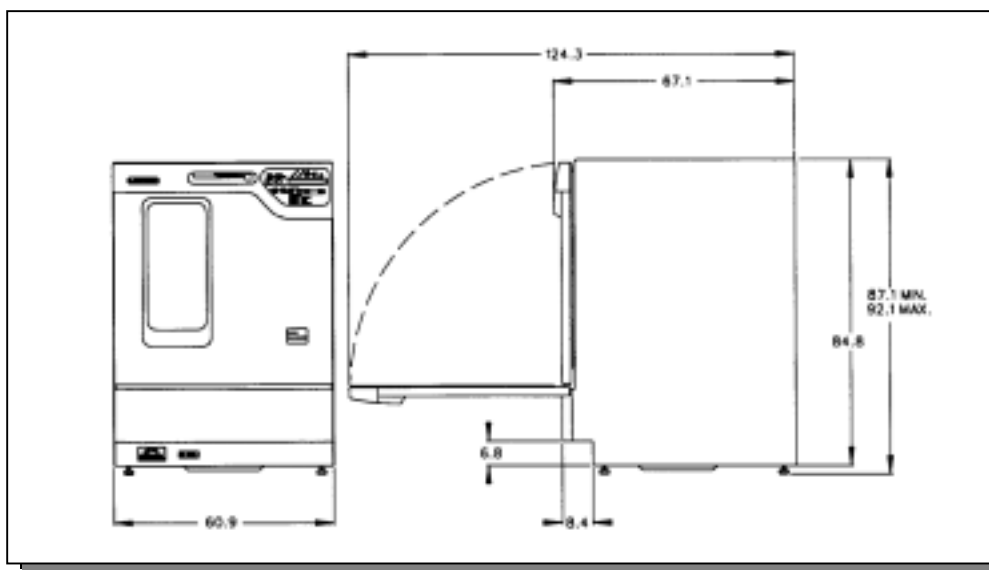

Interior - All SteamScrubbers

Figure B-7

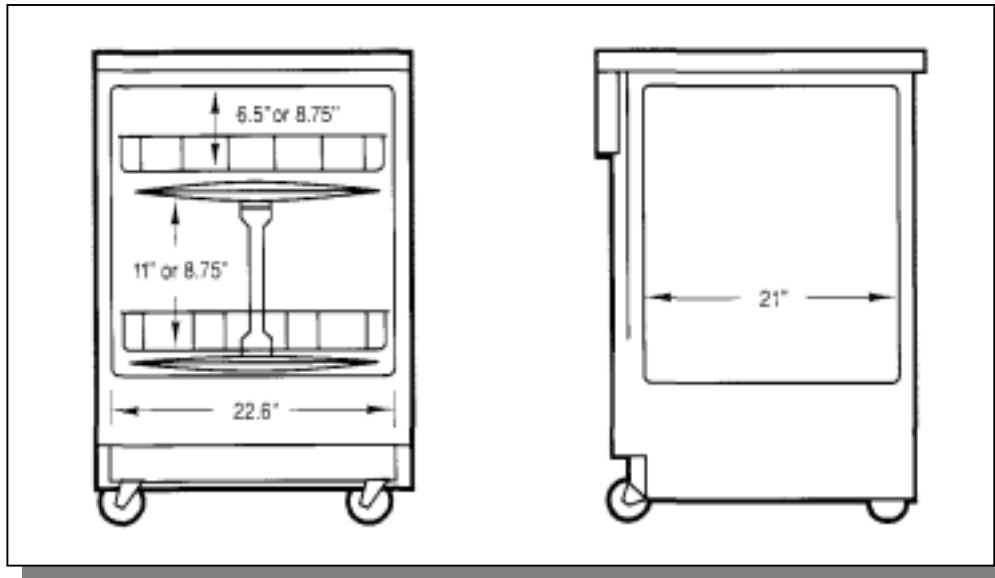

Interior - All FlaskScrubbers

Figure B-8

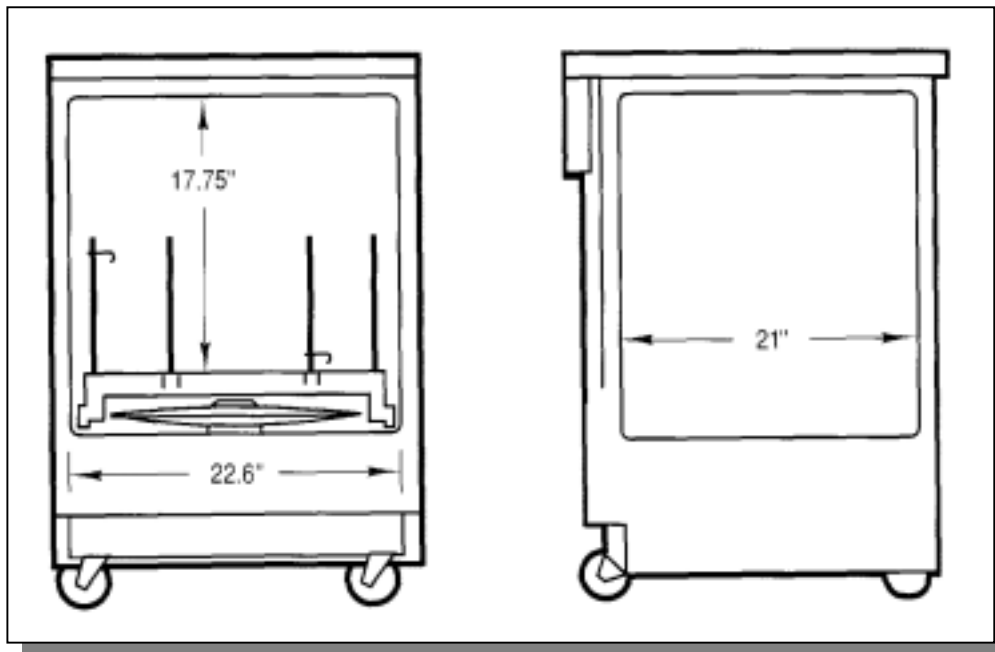

Interior – All FlaskScrubbers with Accessory Upper Spindle Rack

Figure B-8A

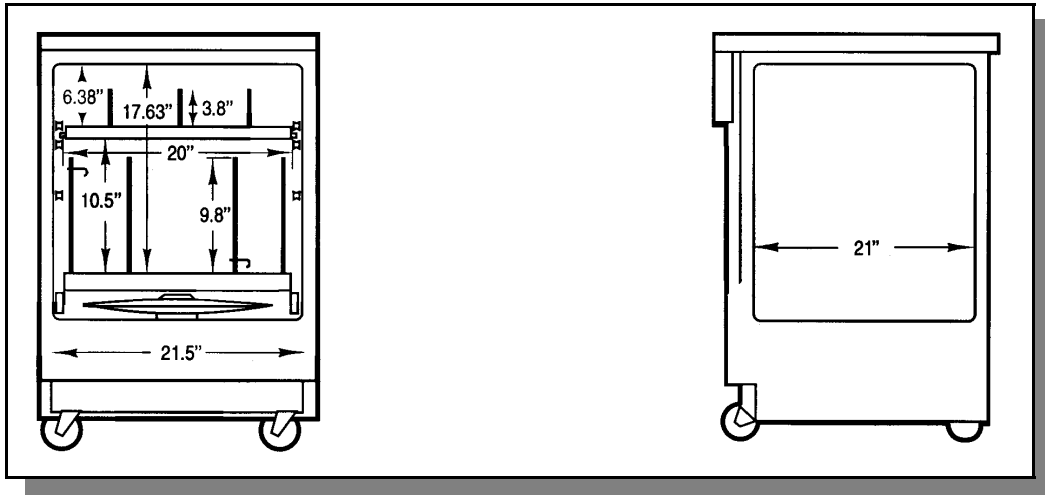

FlaskScrubber Basic Spray Pattern

Figure B-9

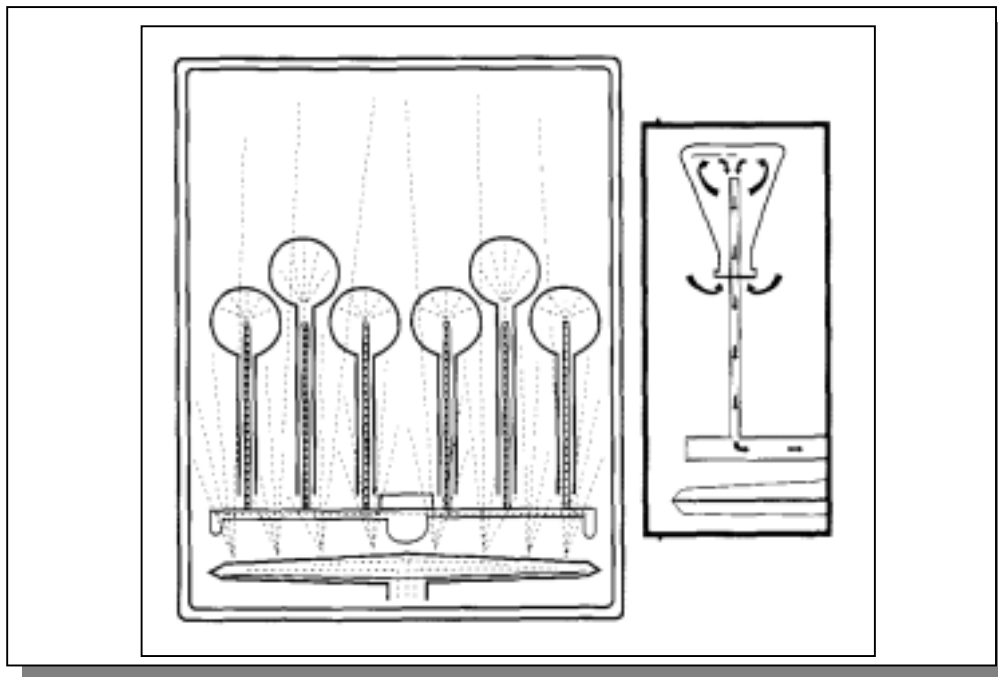

FlaskScrubber Spray Pattern with Accessory Top Rack and Hub Adapter

Figure B-10

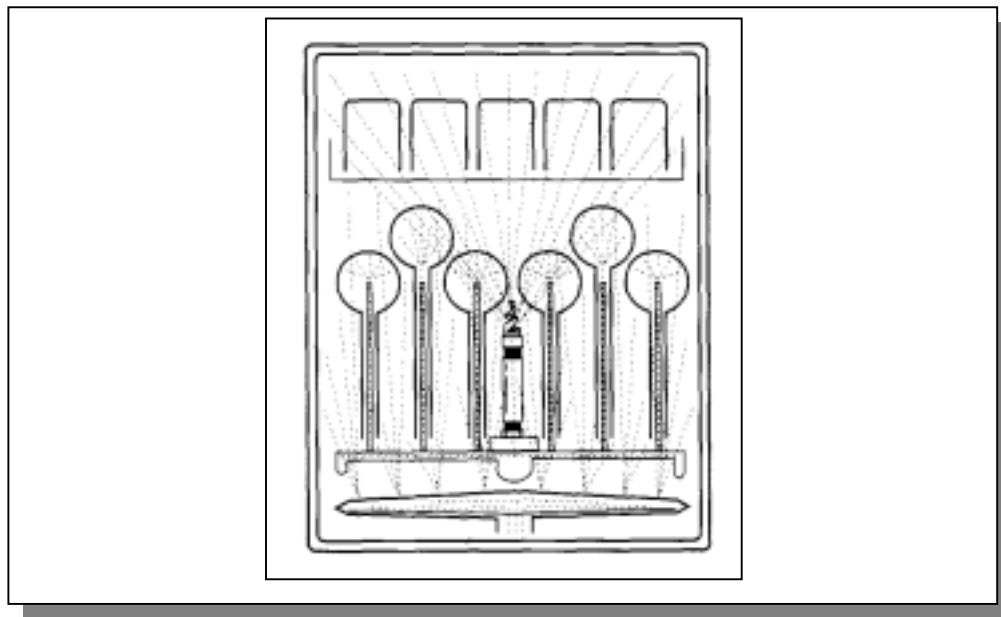

FlaskScrubber Spray Pattern with Accessory Upper Spindle Rack

Figure B-11

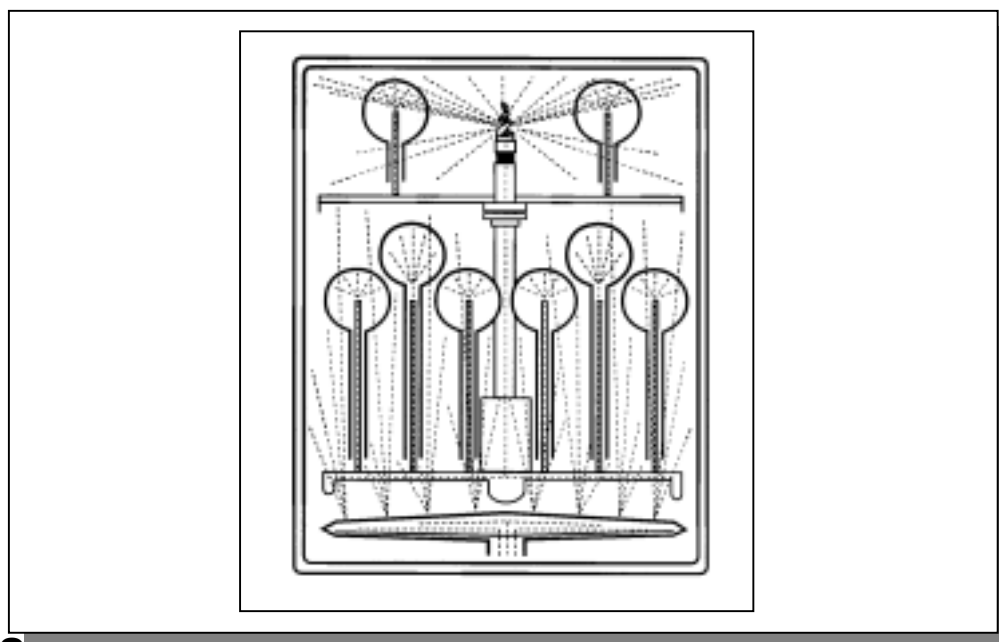

SteamScrubber Spray Pattern

Figure B-12

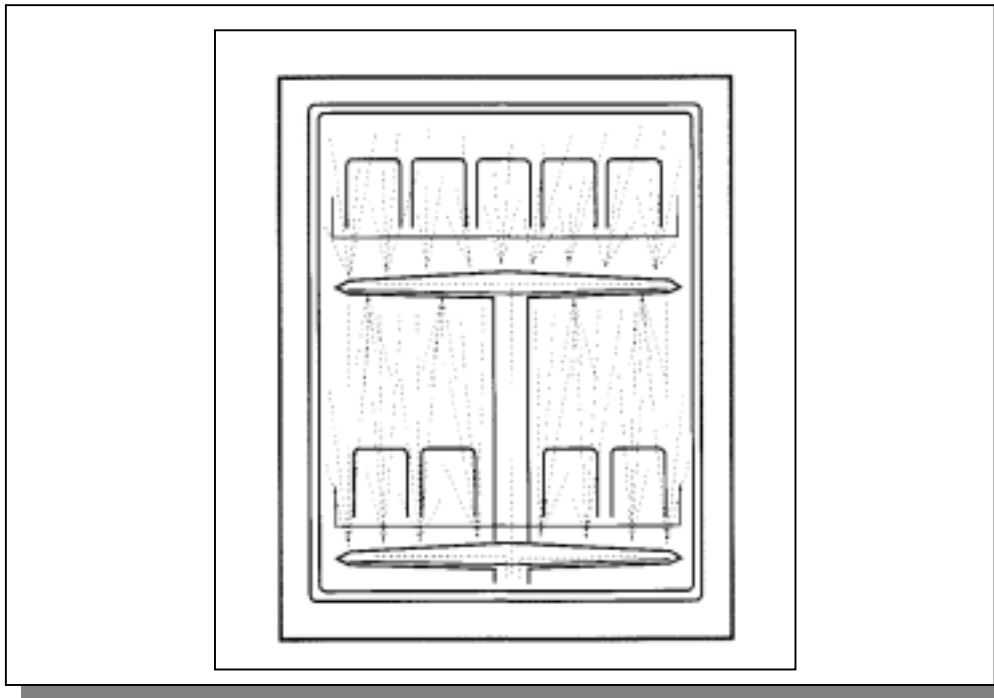

Appendix B: Glassware Washer Dimensions

APPENDIX C

GLASSWARE WASHER SPECIFICATIONS

This Appendix contains various specifications for the Glassware Washer, including program times and water consumption for both the 115V and 230V models, as well as wiring diagrams for the 115V and 230V models.

Glassware Washer Specifications

- Minimum fill water temperature: 120°F (49°C)
- Water consumption per fill: 2.9 gallons (11 liters)
- Minimum feed water pressure: 20 psi (138 kPa)
- Maximum feed water pressure: 120 psi (827 kPa)
- Minimum purified water feed pressure: 0 psi (0 kPa)
- Heat rejected from washer: less than 104 BTU/minute (115V models); less than 170 BTU/minute (230V models)

Electrical Specifications

- Operating voltage for 115V washers: 104/127V
- Operating voltage for 230V washers: 207/253V
- Maximum amperage for 115 volt washers: 16.0 amperes
- Maximum amperage for 230 volt washers: 12.0 amperes
- Frequency 115 volt washers: 60 Hz
- Frequency 230 volt washers: 50/60 Hz
- Phase: Single
- Sump element power: 1,200 watts (115V models); 2,000 watts (230V models)

Environmental Conditions

- Indoor use only.
- Maximum altitude: 6562 feet (2000 meters).
- Ambient temperature range: 41° to 104°F (5° to 40°C).
- Maximum relative humidity: 80% for temperatures up to 88°F (31°C), decreasing linearly to 50% relative humidity at 104°F (40°C).
- Main supply voltage fluctuations not to exceed $\pm 10\%$ of the nominal voltage.
- Transient overvoltages according to Installation Categories II (Overvoltage Categories per IEC 1010). Temporary voltage spikes on the AC input line that may be as high as 1500V for 115V models and 2500V for 230V models are allowed.
- Used in an environment of Pollution degrees 2 (i.e., where normally only non-conductive atmospheres are present). Occasionally, however, a temporary conductivity caused by condensation must be expected, in accordance with IEC 664.

Program Times and Water Consumption (115V Models)

Program	Rinse Only	Plastic	Glass	Glass Plus	Scientific	User 1 Set	User 2 Set
Wash 1		-	5	5	5	5	5
Steam	-	-	†	†	10	†	10
Wash 2	-	10	20*	30*	40*	10*	10*
Rinse 1	4	2	2	2	2	2	2
Rinse 2	**	4	4	4	4	4	4
Rinse 3	**	**	**	4	4	**	**
Rinse 4	**	**	**	4	4	**	**
Rinse 5	**	**	**	**	4	**	**
Rinse 6	-	**	**	**	4	**	**
Dry	0 ††	10 ††	20 ††	30 ††	40 ††	10 ††	10 ††
Total Factory Set Time (minutes)	13	43	71	107	153		
Total User Set Time (minutes)	13 to 108	33 to 158	41 to 176	41 to 176	41 to 176	41 to 176	41 to 176
Total Water Consumed w/ Factory Settings +++	2.9 Gallons (11 liters)	8.7 Gallons (33 liters)	11.6 Gallons (44 liters)	17.4 Gallons (66 liters)	23.2 Gallons (88 liters)	11.6 Gallons (44 liters)	11.6 Gallons (44 liters)

Note: Times shown are for tap rinses. Pure rinses (two final rinses) adds 3 minutes.

†Steam adds 10 minutes to total program time.

* Select from 10, 20, 30, or 40 minute Wash 2 time.

** Additional rinse adds 4 minutes.

††Select from 0, 10, 20, 30, 40, 50, or 60 minute Dry time.

+++Add 2.9 gallons (11 liters) for each additional rinse.

Program Times and Water Consumption (230V Models)

Program	Rinse Only	Plastic Lo Heat	Glass Lo Heat	Glass Plus Hi Heat	Scientific Hi Heat	User 1 Set Lo Heat	User 2 Set Hi Heat
Wash 1		-	5	5	5	5	5
Steam	-	-	†	†	10	†	10
Wash 2	-	10	20*	30*	40*	10*	10*
Rinse 1	4	2	2	2	2	2	2
Rinse 2	**	4	4	25	25	4	25
Rinse 3	**	**	**	4	4	**	**
Rinse 4	**	**	**	4	4	**	**
Rinse 5	**	**	**	**	4	**	**
Rinse 6	-	**	**	**	4	**	**
Dry	0 ††	10 ††	20 ††	30 ††	40 ††	10 ††	10 ††
Total Factory Set Time (minutes)	17	48	77	136	184		
Total User Set Time (minutes)	17 to 116	38 to 167	47 to 186	68 to 207	68 to 207	44 to 186	68 to 207
Total Water Consumed w/ Factory Settings +++	2.9 Gallons (11 liters)	8.7 Gallons (33 liters)	11.6 Gallons (44 liters)	17.4 Gallons (66 liters)	23.2 Gallons (88 liters)	11.6 Gallons (44 liters)	11.6 Gallons (44 liters)

Note: Times shown are for tap rinses. Pure rinses (two final rinses) adds 3 minutes.

†Steam adds 10 minutes to total program time.

* Select from 10, 20, 30, or 40 minute Wash 2 time.

** Additional rinse adds 4 minutes.

††Select from 0, 10, 20, 30, 40, 50, or 60 minute Dry time.

+++Add 2.9 gallons (11 liters) for each additional rinse.

Wiring Diagram (115V Models)

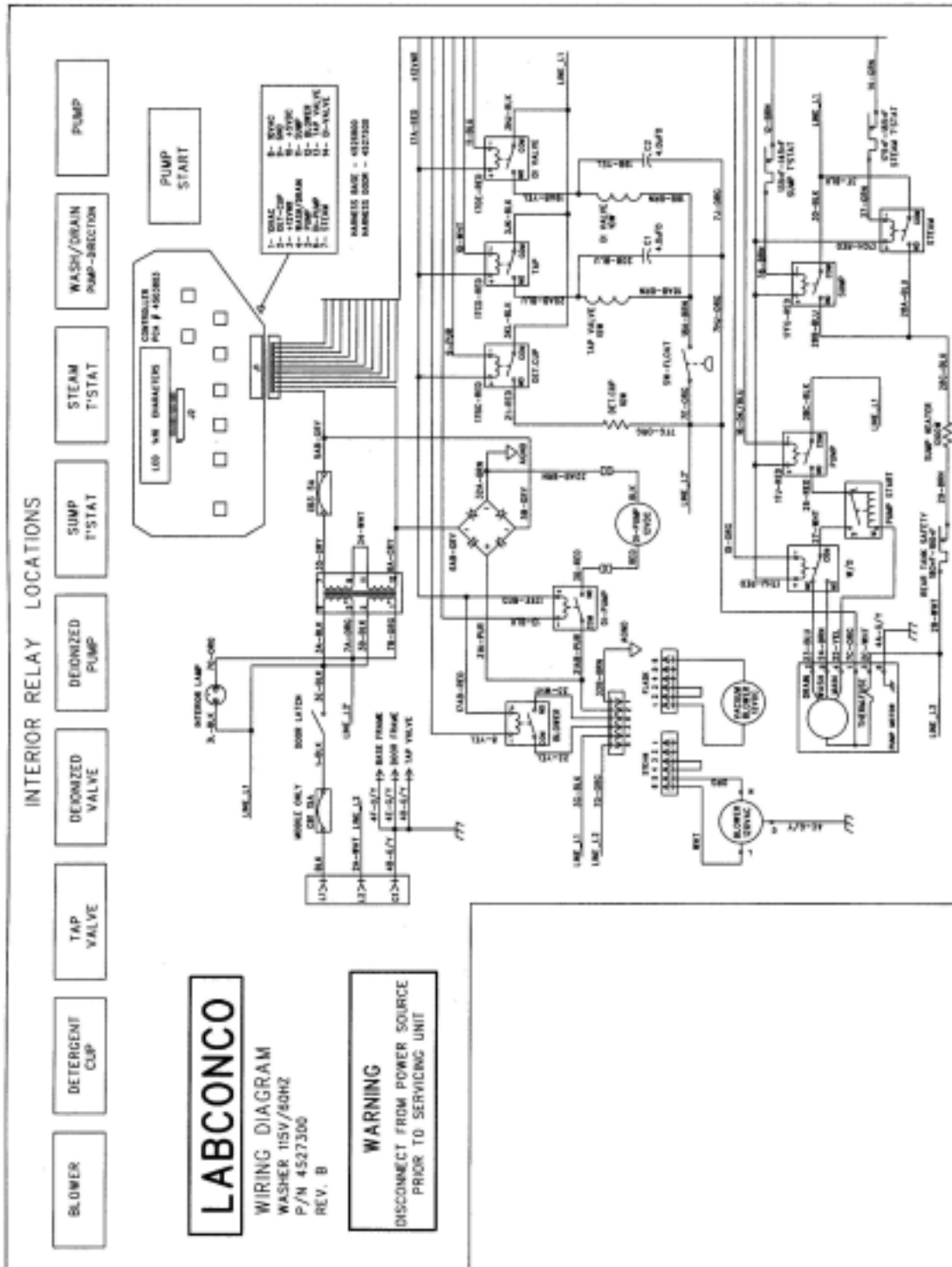

Wiring Diagram (230V Models)

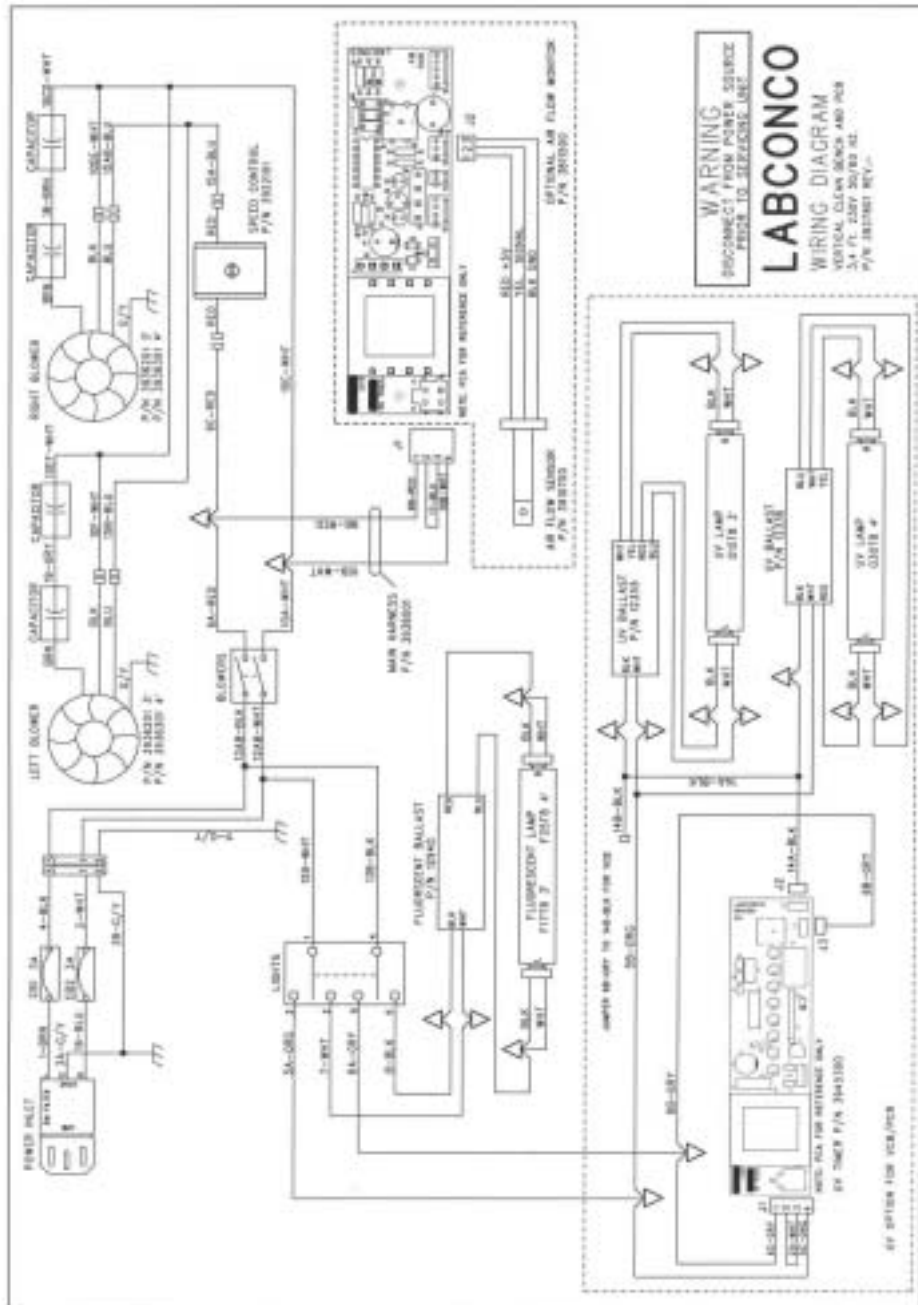



APPENDIX D

GLASSWARE WASHER

ACCESSORIES

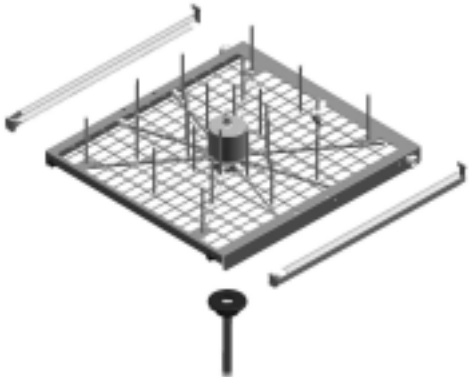
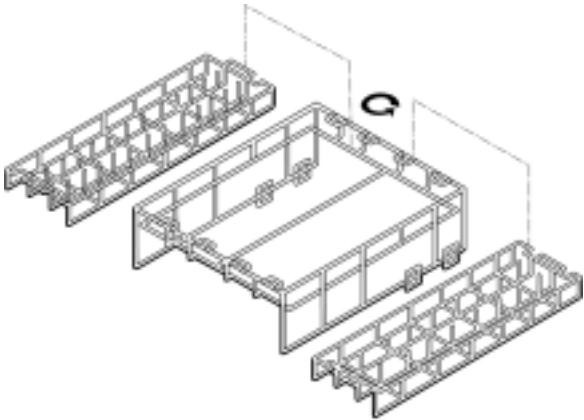
Accessories

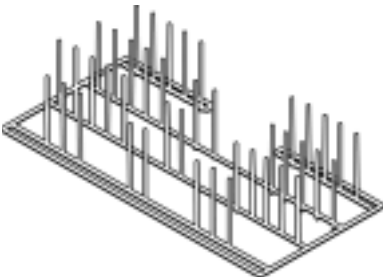
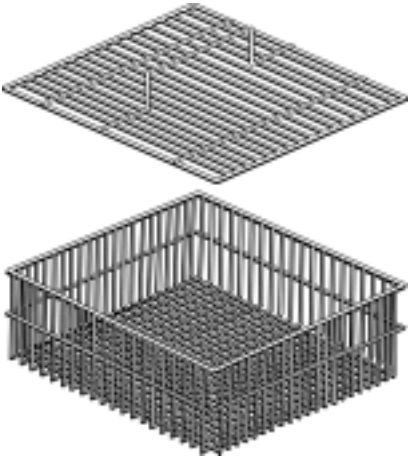
PART #	DESCRIPTION	
45250-00	<p>Upper Spindle Rack – Stainless Steel. Contains one upper spindle rack with 24 spindles and 24 spindle clips, hub adapter, two upper rails with end caps.</p>	
44944-01	<p>Upper Rack, Adjustable Height – Stainless Steel. Contains one upper rack with two inserts, two hub adapters, two upper rails, and two end caps.</p>	

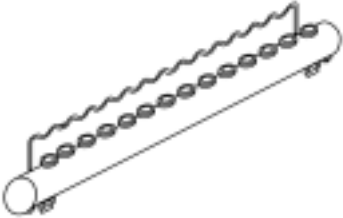
PART #	DESCRIPTION	
44049-01	<p>Multi-Pin Insert – Stainless Steel. For use with beakers, Erlenmeyer flasks, and wide-mouth glassware. For placement in bottom rack.</p>	
44022-01	<p>Utensil Basket – Stainless Steel. For miscellaneous labware such as stoppers, spatulas, small beakers, etc. Furnished with drop-in cover (part number 44038-01).</p>	
44942-00	<p>8-Place Pipet Washer – Stainless Steel. Holds 1 ml to 10 ml pipets.</p>	
44943-01	<p>14-Place Pipet Washer – Stainless Steel. Holds 1 ml to 50 ml pipets.</p>	

Appendix D: Glassware Washer Accessories

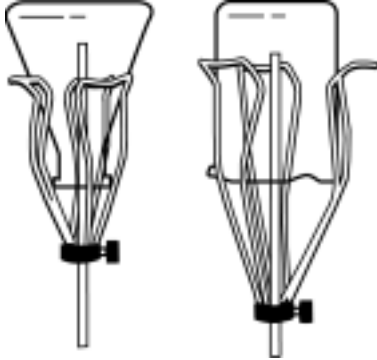
PART #	DESCRIPTION	
44246-00	Glassware Holder – Small. Grips wide-mouth glassware over spindles.	
44248-00	Glassware Holder – Large. Grips wide-mouth glassware over spindles.	
91002-00	Interconnect Kit. Allows WaterPro RO Station to be attached to the glassware washer.	
90750-00	WaterPro RO Station. Provides purified water for the final rinses. 115V, 60 Hz.	
90750-02	WaterPro RO Station. Provides purified water for the final rinses. 230V, 50 Hz.	
90672-01	Prefilter/Carbon Kit. Includes 3 prefilters and 3 carbon filters.	
90787-00	Reverse Osmosis Membrane.	

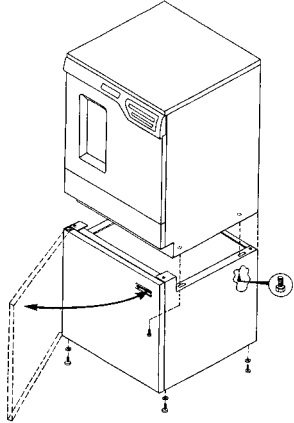
PART #	DESCRIPTION	
45800-00	Stand. For use with Freestanding and Mobile models. Raises washer approximately 17 inches. Front opens to provide storage underneath washer.	 A technical line drawing of a rectangular stand designed for a glassware washer. The stand has a front door that is shown in an open position, indicated by a curved arrow. The washer is mounted on top of the stand. The stand has four legs, each with a small circular base. A small circular detail with a screw symbol is shown on the right side of the stand, indicating a fastener. The drawing uses solid lines for the main structure and dashed lines for the open door and some internal components.

SteamScrubber Accessories

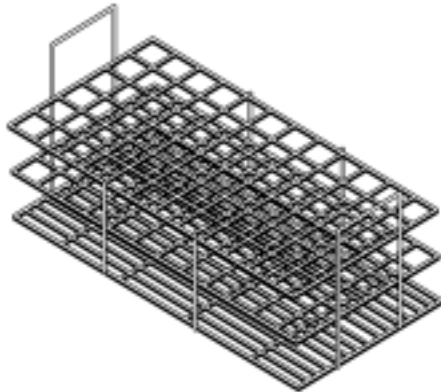
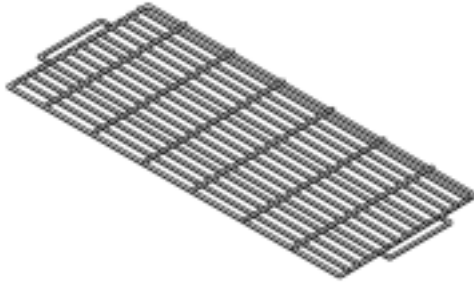
PART #	DESCRIPTION	
44016-01	<p>Culture Tube/Test Tube Insert – Stainless Steel. Insert for 10 mm to 12 mm tubes.</p>	
44020-01	<p>Culture Tube/Test Tube Insert – Stainless Steel. Insert for 15 mm to 18 mm tubes.</p>	
44021-01	<p>Culture Tube/Test Tube Insert – Stainless Steel. Insert for 20 mm to 25 mm tubes.</p>	
4401301	<p>Culture tube/Test Tube Insert – Stainless Steel. Insert for 10 mm to 12 mm tubes. Includes 44016-01 and retainer top 4401401</p>	
44014-01	<p>Retainer Top for Culture Tube Insert – Stainless Steel. For use with all culture tube inserts to keep lightweight tubes in place under water pressure.</p>	

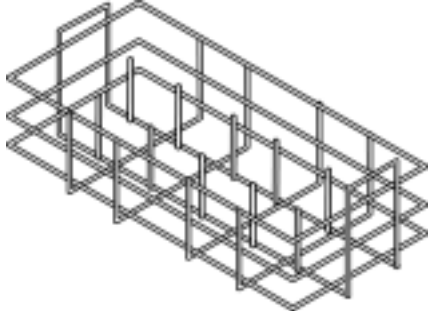
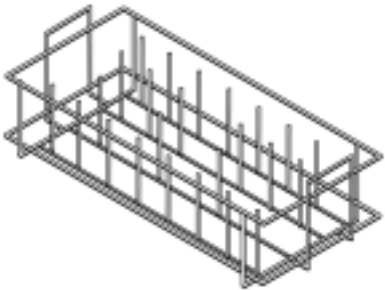
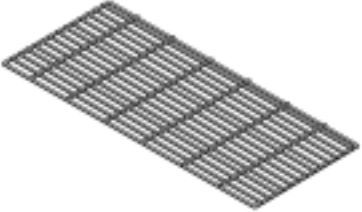
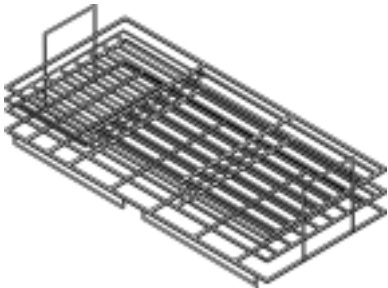
PART #	DESCRIPTION	
44015-01	<p>10-Pin Insert – Stainless Steel. For use with beakers, Erlenmeyer flasks, and other wide-mouth glassware.</p>	
44018-01	<p>32-Pin Insert – Stainless Steel. For use with beakers, Erlenmeyer flasks, and other wide-mouth glassware.</p>	
44019-01	<p>Retainer Top – Stainless Steel. To keep lightweight flasks in place under water pressure. For use with 44018-01 or 44015-01.</p>	
44042-01	<p>Petri Dish Insert – Stainless Steel. For plates, petri dishes, and watch glasses.</p>	

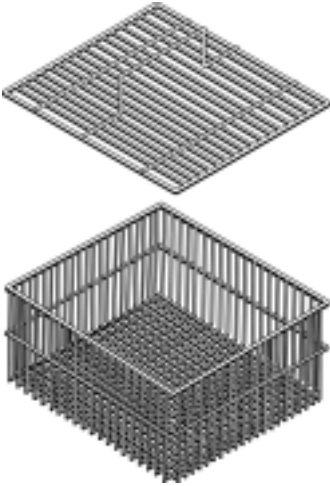
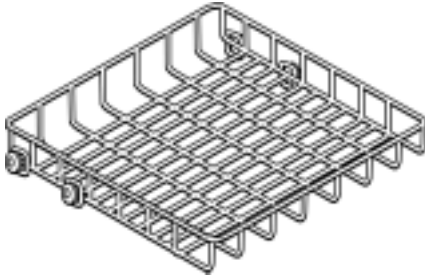
PART #	DESCRIPTION	
44048-01	<p>BOD Rack/Beaker/ Erlenmeyer Flask Insert – Stainless Steel. Rack secures glassware used in oxygen-demand determination, beakers, and Erlenmeyer flasks.</p>	
44022-01	<p>Utensil Basket – Stainless Steel. For miscellaneous labware such as stoppers, spatulas, small beakers, etc. Furnished with drop-in cover (part number 44038-01).</p>	
44011-02	<p>Top Rack – Stainless Steel. Included with washer.</p>	

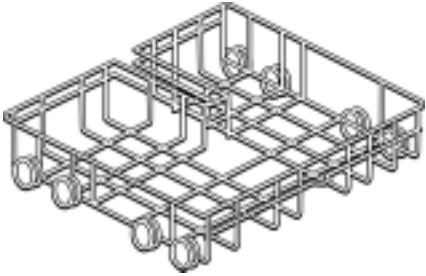
PART #	DESCRIPTION	
44012-02	Bottom Rack – Stainless Steel. Included with washer.	
91002-00	Interconnect Kit. Allows WaterPro RO Station to be attached to the washer.	
90750-00	WaterPro RO Station. Provides purified water for the final rinses. 115V, 60 Hz.	
90750-02	WaterPro RO Station. Provides purified water for the final rinses. 230V, 50 Hz.	
90672-01	Prefilter/Carbon Kit. Includes 3 prefilters and 3 carbon filters.	
90787-00	Reverse Osmosis Membrane.	

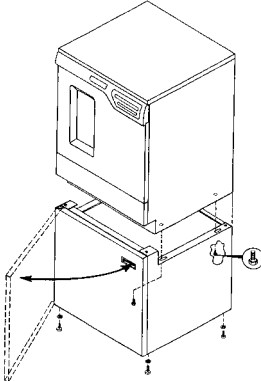
PART #	DESCRIPTION	
45800-00	<p>Stand. For use with Freestanding and Mobile models. Raises washer approximately 17 inches. Front opens to provide storage underneath washer.</p>	

EXPENDABLES

PART #	DESCRIPTION
44220-00	10-lb. LabSolutions Powder Detergent
44221-00	27.5-lb. LabSolutions Powder Detergent
45220-00	1 gallon LabSolutions Liquid Detergent
45222-00	1 liter LabSolutions Neutralizing Acid Rinse

DECLARATION OF CONFORMITY

Application Council Directive(s): 73/23/EEC, 89/336/EEC

Standard(s) to which conformity is declared: EN61010, EN55022, EN50082-1

Manufacturer's Name: Labconco Corporation

Manufacturer's Address: 8811 Prospect Avenue
Kansas City, MO 64132 USA

Importer's Name: See Shipping/Customs Documents*

Importer's Address: See Shipping/Customs Documents for your equipment

Type of Equipment: Laboratory Equipment – Glassware Washers

Model No.: Washers with Micro Processor Control

44000-01 – 230V Steamscribber - Mobile	44200-01 – 230V Flaskscribber – Mobile
44000-11 – 230V Steamscribber - Mobile	4420011 – 230V Flaskscribber – Mobile

44003-01 – 230V Steamscribber – Undercounter	44203-01 – 230V Flaskscribber – Undercounter
44003-11 – 230V Steamscribber – Undercounter	44203-11 – 230V Flaskscribber – Undercounter

44004-01 – 230V Steamscribber – Freestanding	44204-01 – 230V Flaskscribber – Freestanding
44004-11 – 230V Steamscribber – Freestanding	44204-11 – 230V Flaskscribber - Freestanding

Serial No.: Various – See Individual Declaration

Year of Manufacture: 1997 and Subsequent

I, the undersigned, hereby declare that the equipment specified above conforms to the above Directive(s) and Standard(s).

See individual Declaration of Conformity which
will be signed by the importer for your country.

Place: _____

(Signature)

Date: _____

(Full Name)

(Position)

*An individual version of this declaration is included with your shipping/customs documentation.

Labconco P/N 36960-13 REV A ECO B296