



Grandstream Networks, Inc.

GXV3611 User Manual

Safety Instructions

These instructions are intended to assist users with the operation of the GXV3611 and also to instruct on how to avoid dangerous situations or damage to the device.

Warnings: Serious injury or death may be caused if any of the warnings below are neglected.

Cautions: Injury or damage to the equipment may occur if any of the following caution messages are neglected.



Warnings Follow these safeguards to prevent serious injury or death.



Cautions Follow these precautions to prevent potential injury or material damage.



Warnings:

Input voltage should meet both the SELV (Safety Extra Low Voltage) and the Limited Power Source with DC 12V according to the IEC60950-1 standard. Please refer to the technical specifications for more details.

Do not use a third-party power adapter or power cord

When the device is installed on the wall or ceiling, make sure that it is firmly attached.



Notice:

Make sure that the power supply voltage is correct before using the camera.

Do not drop the device or expose it to physical shock.

Do not expose the device to temperatures outside the range of -10 °C to +60 °C when the device is in operation.

Do not expose the device to damp/wet conditions or high electromagnetism radiation.

To avoid heat accumulation, make sure that your operating environment has proper ventilation.

Do not attempt to open, disassemble, or modify the device

A few parts (e.g. electrolytic capacitor) of the equipment shall be replaced regularly according to their average life time. The average life time varies from the differences between operating environments and usage history. Regular maintenance checks are recommended for all users. Please contact your dealer for more details.



Notice:

The smoke detector in the GXV 3611 mini dome camera is not intended to replace any smoke

detector alarm system. The smoke detector does not comply with the National Alarm and Signaling Code, nor does it provide any form of visual or audible signal to alert the premises dwellers. You must not replace any existing smoke alarm system with this product.

Contents

Welcome	5
Package Contents	6
Product Overview	7
GXV3611 Overview	7
GXV3611 Side View.....	7
GXV3611 Sample Connection Diagram.....	7
GXV3611 Key Features.....	8
GXV3611 Lens Specification	9
Minimum Recommended System Requirement	11
Connect your GXV3611	11
Configuring the GXV3611 via Web Browser	12
Access GXV3611 Web Configuration Menu.....	12
GXV3611 Home Web Page	13
GXV3611 Status Page	15
GXV3611 Video & Audio Page.....	15
GXV3611 Networking Page.....	17
GXV3611 DDNS Page	18
GXV3611 SIP Page.....	18
GXV3611 Date & Time Page	20
GXV3611 Maintenance Page.....	21
GXV3611 Administrator Page	21
GXV3611 Change Password Page.....	22
GXV3611 SMTP Page.....	22
GXV3611 FTP Page	23
GXV3611 Alarm Event.....	23
GXV3611 Motion Detection.....	26
GXV3611 System Log.....	28
FAQ.....	29

Welcome

The GXV3611 is a next generation mini IP dome camera for remote monitoring and surveillance over your LAN or internet.

The GXV3611 combines best in class IP video technology and SIP protocols for a robust IP surveillance solution. The product features H.264 video streams with up to 30 frames per second in full D1, delivering rich image clarity at rapid transmission rates. Integrated SIP can pass alarms to the PSTN, mobile phones, SIP IP phones, SIP videophones and enables 2-way VoIP communication.

The GXV3611 ensures ease of use, integration and deployment with a multilingual graphical user interface. The GXV3611 can be quickly installed and connected to your network and accessed from anywhere over the internet. Grandstream's flexible video management software enables users to monitor multiple environments in one easy to use application. The intuitive web interface lets users easily access, manage, view and record live video streams from the device.

The GXV3611 is a powerful solution for small to medium sized offices, homes and storage facilities looking to safeguard their valuables.

Package Contents

Items in the package:

- GXV3611 IP Camera
- 12V DC power Adapter
- Quick installation guide



GXV3611



Power Adapter

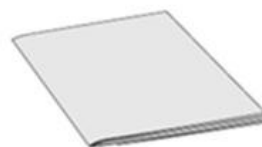

Quick Installation Guide

Product Overview

GXV3611 Overview



GXV3611 Side View



GXV3611 Sample Connection Diagram

Connectors and cables

PINs – Alarm In connector, and Alarm out connector.

AUDIO IN – 3.5mm port for audio input devices (microphone, pickup and etc.).

NETWORK – 10/100 Switch LAN port for connecting to Ethernet. The indicator will be steady for connection and flashing for network activity.

AUDIO OUT – 3.5mm port for audio output devices (speakers, and etc.).

DC 12V – 12V DC power jack; UL Certified.

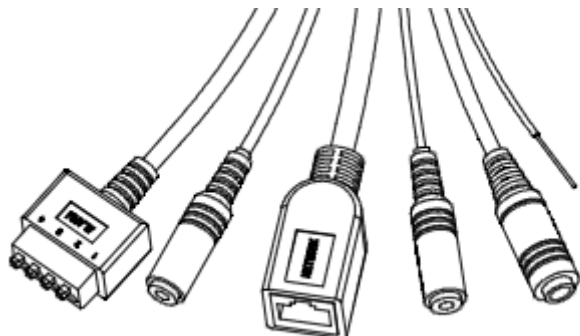

POWER – The indicator will be **solid green** if the power is on.

Ground – wire used for grounding

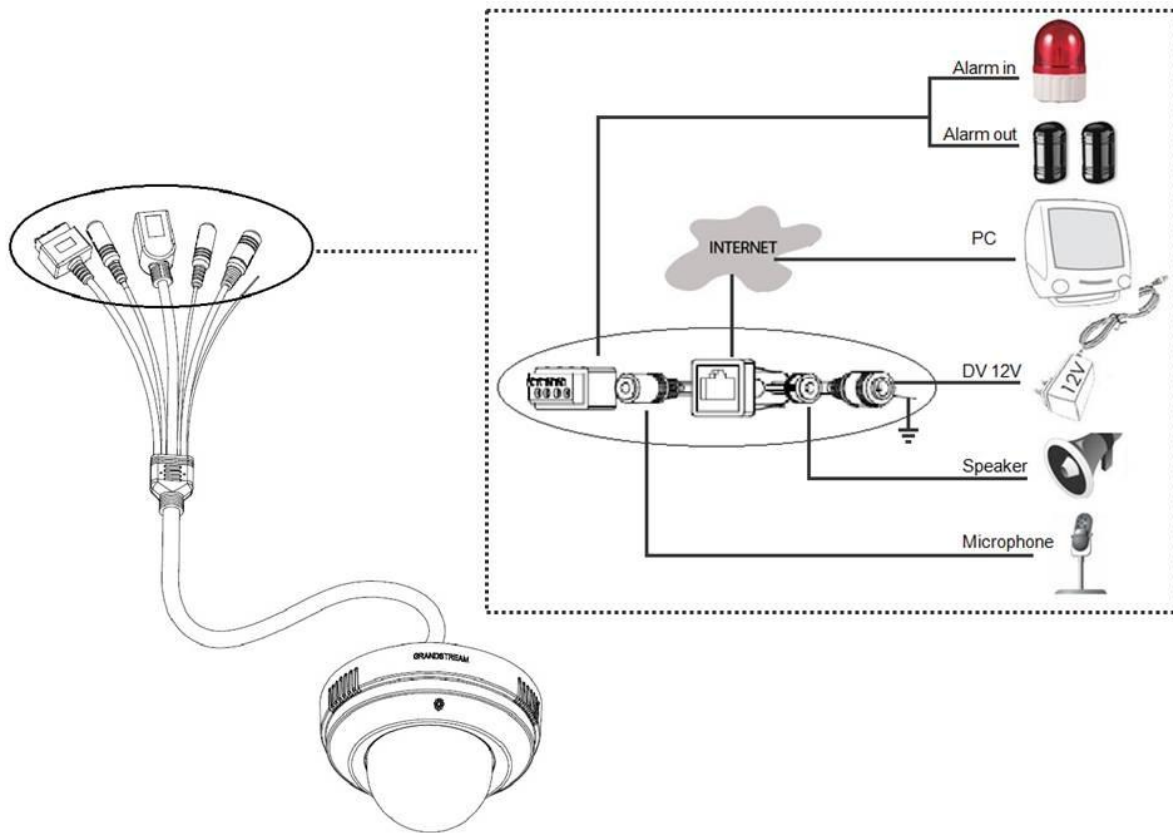

GXV3611 Key Features

The table below lists the key features the GXV3611 Supports.

Features	GXV3611-HD	GXV3611-LL
Image Sensor	1/3.2", 2-Megapixel CMOS, 1600H x 900V	1/4", CMOS, 680H x 512V
Lens Type	1/3", 4.2mm, F1.8, Mega, fixed focal length, changeable	1/4", 4.5m, F 1.9 fixed focal length, VGA, changeable
Minimum Illumination	0.05Lux at F1.2	
Video Compression	H.264, JPEG, Motion JPEG	
Max Video Resolution	1600x900; 1280x720; 800x450; 640x360; 480x270; 320x180; EPTZ	640x480 (VGA), 320x240 (QVGA), 720x480 (NTSC D1), 352x240 (NTSC CIF), 176x112 (NTSC QCIF); 720x576 (PAL D1), 352x288 (PAL CIF), 172x144 (PAL QCIF)
Max Frame Rate in	20fps for 1600x900,	30fps for VGA & NTSC

Max Resolution	30fps for 1280 x 720, 800x450, 640x360, 480x270, 320x180	25fps for PAL
Video Bit Rate	32 Kbps – 8 Mbps	32 Kbps – 2 Mbps
Video Output	N/A	1BNC (voltage 1.0Vp-p, resistance 75)
Audio Input	3.5mm LINE IN	
Audio Output	3.5mm LINE OUT	
Audio Compression	G.711, G.726	
Alarm Input	Yes -1, Normal Open	
Alarm Output	Yes -1	
Serial Ports	RS485	
Embedded Analytics	Motion Detection (up to 16 target areas), video loss (pending)	
Pre-/post alarm buffer	24MB	
Snapshots	Triggers upon alarm events, send via email/FTP	
Network Protocol	TCP/UDP/IP, RTP/RTCP, RTSP, DHCP, DDNS, HTTP, HTTPS, SMTP, FTP, SIP	
Network Port	10M/100M auto-sensing, RJ45	
Multi-streaming-rate for Preview and Recording	Yes	
Security	password, multi-privilege login	
Power over Ethernet (PoE)	Standard, IEEE 802.3af Class 3	
SIP/VoIP Support	Yes	
Weight	0.43Kg	0.43Kg
Dimension	138mm(D)*85.6mm(H)	138mm(D)*85.6mm(H)
Temperature / Humidity	0°C – 45°C(32°F–133°F) Humidity 10–90% RH (non-condensing)	0°C – 45°C(32°F–133°F) Humidity 10–90% RH (non-condensing)
Power	Output: 12VDC/1.5A; Input: 100–240VAC, 50–60Hz	Output: 12VDC/1.5A; Input: 100–240VAC, 50–60Hz
Compliance	FCC Part 15, Subpart B Class B; EN 55022 Class B, EN 61000-3-2, EN 61000-3-3, EN 55024, EN 60950-1; C-tick AS/NZS CISPR 22, CISPR 24	FCC Part 15, Subpart B Class B; EN 55022 Class B, EN 61000-3-2, EN 61000-3-3, EN 55024, EN 60950-1; C-tick AS/NZS CISPR 22, CISPR 24

GXV3611 Lens Specification

Parameters	GXV3611-HD	GXV3611-LL
Lens Mount	M12	M12

Lens Format	1/3" 2 Mega pixels	1/4"
Focal Length	4.2 mm	4.5 mm
Aperture (D/f')	1.8	1.9
View Angle	71	64
Size (Diameter x Length 1 x Length 2)	14x15.8mm	14x12.91mm

Installation Guide

Minimum Recommended System Requirement

- Windows 2000 Server Professional, Windows XP, Windows Vista.
- CPU: Intel Pentium 4 or higher, 2 GHz.
- RAM: 1 GB (4 GB recommended for larger systems).
- Support for DirectX 8.0 and above.

Connect your GXV3611

Using the Power adapter as power supply

- Connect an RJ-45 cable to the NETWORK port of the GXV3611.
- Connect the other end of the RJ-45 cable to your network or PC.
- Connect the power supply to the DC 12V power jack on the back of the GXV3611.
- Connect the other end of the power supply to a wall outlet. The POWER LED will turn solid green.

Using PoE as power supply:

- Connect an RJ-45 to the NETWORK port of GXV3611.
- Connect the other end of the RJ-45 cable to a PoE switch. The POWER indicator will turn solid green.

NOTE: If you are going to connect the device to a hub/switch/router, please use a straight-through cable. A cross over cable should be used if you are going to connect the device directly to a PC.

Configuring the GXV3611 via Web Browser

The GXV3611's embedded Web server responds to HTTP/HTTPS GET/POST requests. Embedded HTML pages allow you to configure your IP camera through Microsoft Internet Explorer.

Access GXV3611 Web Configuration Menu

- Connect your PC to the same network as the GXV3611.
- Configure the IP address of your PC to: 192.168.1.XXX (1<XXX<255) and configure the subnet mask to 255.255.255.0.
- Make sure that the device is turned on and connected to the network.
- Start Internet Explorer on your computer.
- Enter 192.168.1.168 in the address bar of the browser.
- Enter the administrator user name and password to access the Web Configuration Interface
- The default user name and password are both set to **admin**.
- IE will indicate that "This website wants to install the following add-on: 'GSViewerX.cab' from 'Grandstream Networks Inc'." Install this add-on by following the instructions in IE.
- You will see the home page.

GXV3611 Home Web Page

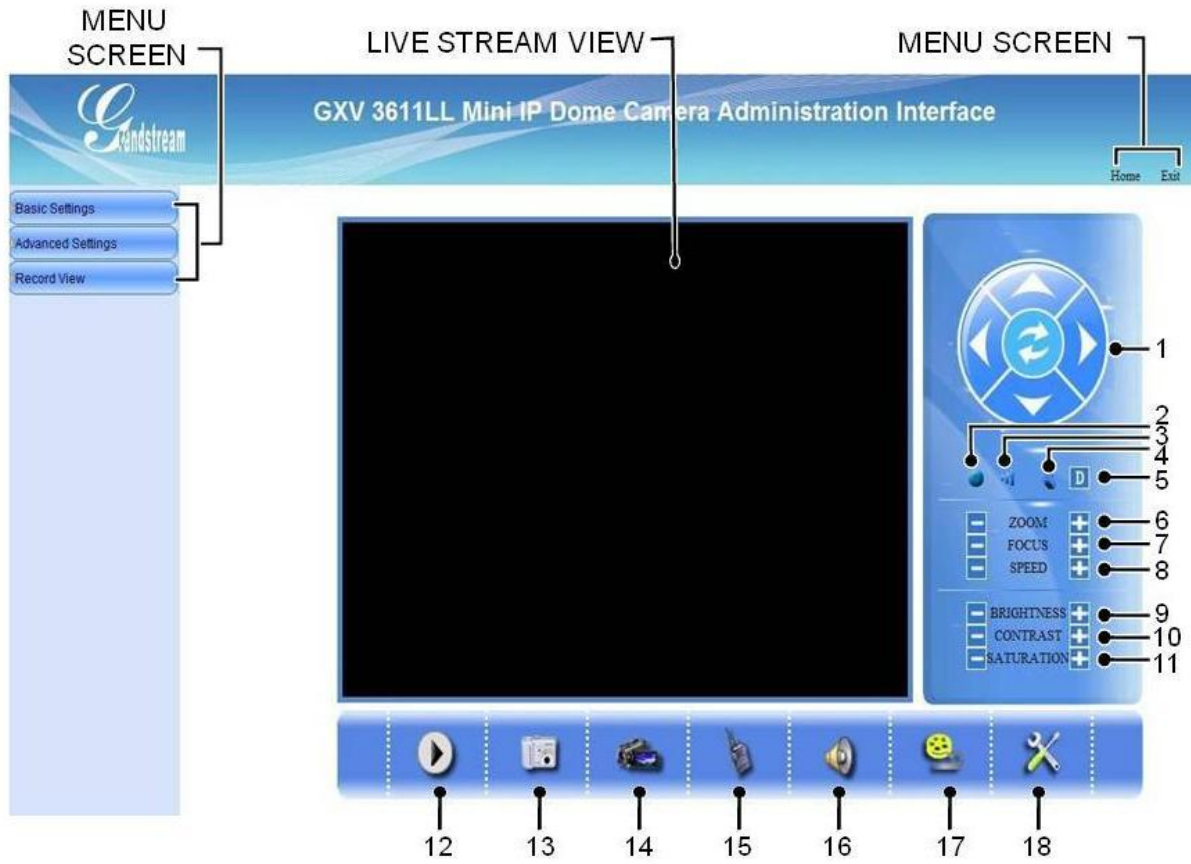

Figure2: Home web page of GXV3611-LL

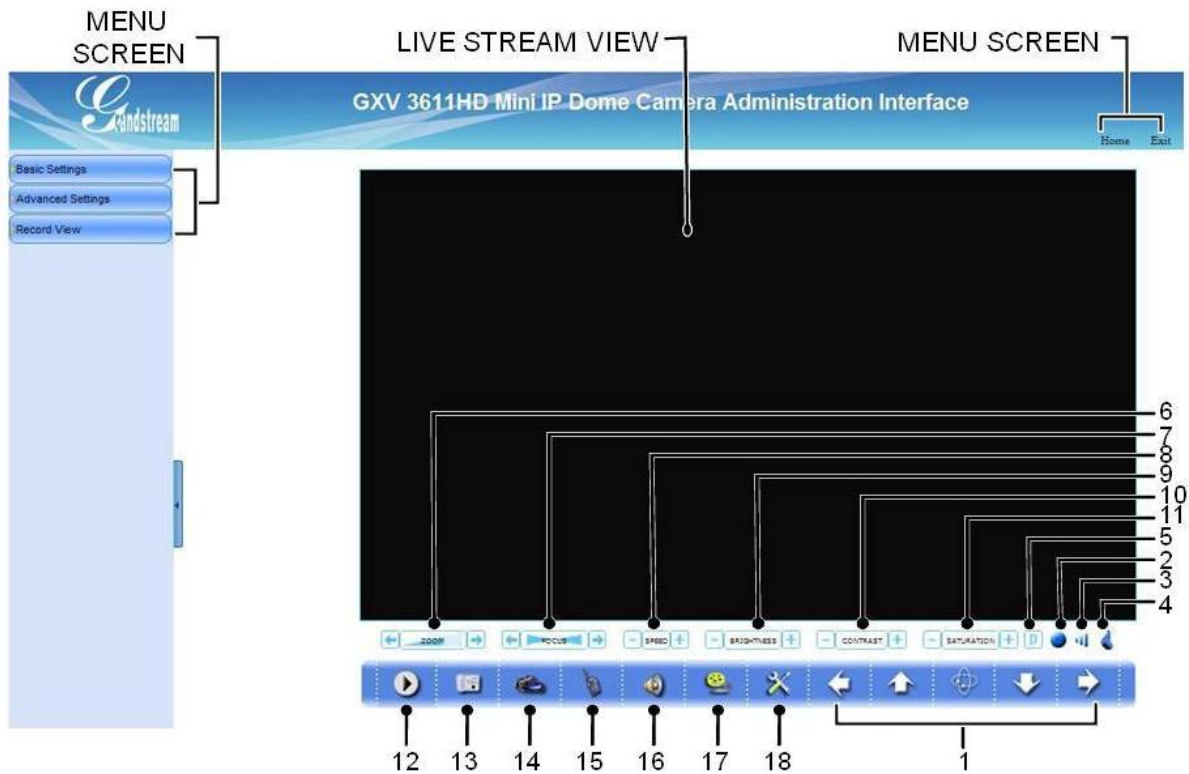

Figure3: Home web page of GXV3611-HD

Items on GXV3611 Home Page

- | | |
|---------------------------|---|
| 1 Control Console | PTZ Console controller. PTZ device needs to be connected. |
| 2 Motion Detection | If the motion detection alarm is triggered, the indicator will flash red . Click on the indicator to turn off the alarm. |
| 3 Alarm Event | If an alarm event is triggered, the indicator will flash red . Click on the indicator to turn off the alarm. |
| 4 Smoke Detector | If alarm is triggered for smoke detector, the indicator will flash red . Click on the indicator to turn off the alarm. |
| 5 Default | Click this option to reset the video brightness, contrast, and saturation to their factory default configuration. |
| 6 ZOOM | Zoom in/Zoom Out |
| 7 FOCUS | Adjusts the focus of images. |
| 8 SPEED | Adjusts the rotation speed of the console. |
| 9 BRIGHTNESS | Adjusts the image brightness. |
| 10 CONTRAST | Adjusts the image contrast. |
| 11 SATURATION | Adjusts the image saturation. |
| 12 Play | Plays/Stops the video. |
| 13 Capture | Captures the image displayed and saves it to C:\GS_Capture (default directory). |
| 14 Record | Records the video and saves it to C:\GS_Record (default directory). |

- 15 Talk** Establishes two-way audio.
- 16 Sound Off/On** Toggles the sound On or Off.
- 17 Playback** Replays the saved video.
- 18 Config** Configures the Save Location for captured images and recorded videos.

Note: PTZ is not supported by GXV3611LL. PTZ controls work when GXV3611HD is set to EPTZ.

GXV3611 Status Page

System Statistics

System Statistics lists hardware and software information, for example, the part number, the software version, about the GXV3611.

Hardware Version – This field contains the product’s hardware information.

Part Number – This field contains the product part number information.

Bootloader Version – Bootloader code version number.

Core Version – Core code version number.

Base Version – Base code version number.

Firmware Version – Firmware code version number.

System Up Time Since – This field shows the system up time since the last reboot.

System Statistics	
Product Model:	GXV3611HD
Hardware Version:	V0.3A
Part Number:	9670000103A
Bootloader Version:	1.0.2.0
Core Version:	1.0.3.1
Base Version:	1.0.3.5
Firmware Version:	1.0.3.5
System Up Time Since:	55 minutes

Network Status

MAC Address – The device ID, in HEXADECIMAL format.

LAN IP Address – This field shows the LAN IP address of the GXV3611.

LAN Subnet Mask – This field shows the LAN subnet mask of the GXV3611.

LAN Default Gateway – This field shows the LAN default gateway of the GXV3611.

DDNS Status – This field shows the status of DDNS.

MAC Address:	00:0B:82:00:00:00
LAN IP Address:	192.168.1.168
LAN Subnet Mask:	255.255.255.0
LAN Default Gateway:	192.168.1.1
DDNS Status:	Disabled

Camera Type

This section shows the Lens information of GXV3611. The Lens type information contains the brand name, the size of image sensor, the resolution and so on.

GXV3611 Video & Audio Page

Video Settings

Preferred Video Codec – The GXV3611 supports the H.264 video codec.

Resolution – The higher the resolution is, the better the video quality is, and higher bandwidth is required.

Resolution Low -----> High
 QCIF CIF 2CIF D1

Bit Rate – The number of bits that are conveyed or processed per unit of time.

Maximum Frame Rate – The video frame

rate is adjustable based on network conditions. *Increasing the frame rate will increase the amount of data significantly therefore consuming more bandwidth.* Video will be impaired due to packet loss when there is insufficient bandwidth.

Bit Rate Control – Variable Bit rate (VBR) and Constant Bit Rate (CBR).

Variable Bit Rate - If VBR is selected, the codec varies the amount of output data per time segment. VBR produces a better quality-to-space ratio. The bits available are used to enable more flexibly and encode sound or video data more accurately, with fewer bits used in less demanding passages and more bits used in difficult-to-encode passages.

Constant Bit Rate - If CBR is selected, the codec's output data is constant regardless of the input data. The output bit rate is defined in "Bit rate". CBR is useful for streaming multimedia content on limited capacity channels. It is easier to calculate required bandwidth as well as the required storage space using CBR.

Image Quality – If 'Bit Rate Control' is set to "VBR", "Image quality" needs to be configured. The better the video quality is, the higher the bit rate will be.

I-frame Interval – While streaming video over a network, compression technologies are used to show the incremental difference between each frame. I-frames are used to help keep the video looking normal. When intervals are shorter, the video quality is higher but uses more bandwidth.

Preferred Video Codec:	H264
Resolution:	D1 704*480
Bit Rate:	1024 kbps
Maximum Frame Rate:	30 fps
Bit Rate Control:	<input checked="" type="radio"/> CBR <input type="radio"/> VBR
Image Quality:	Normal
I-frame Interval:	30 Frame (1-100)

NOTE: The users might need to configure the **Primary Stream** and **Secondary Stream** properly. Sometimes, the user might like to watch the live video stream from the web GUI in low resolution mode while recording a copy via GSurf/GS_NVR in high resolution due to the limitation of internet bandwidth. In this case, for example, primary stream can be configured to have better resolution, and then the users can use primary stream to record while watching secondary video streams.

Audio Settings

Preferred Audio Codec:	PCMA	Audio Compression:	32 kbps
Microphone Volume:	3	Speaker Volume:	10
Line In:	Internal	Line Out:	Internal

Audio Compression – Audio compression is a form of data compression designed to reduce the size of audio files. Usually, the higher the audio compression is, the better the audio quality is.

Preferred Audio Codec – The GXV3611 supports up to 3 different Vocoder types, a-law (PCMA), u-law (PCMU) and G.726.

Line In – toggle between build-in microphone and external microphone.

Microphone Volume – Set the volume of the microphone chosen in “Line in”

Line Out - toggle between build-in microphone and external speaker.

Speaker Volume - Set the volume of the microphone chosen in “Line out”

Power Frequency

Frequency - The frequency of provided power. This setting is only available for GXV3611HD.

Frequency: Hz

On Screen Display (OSD) Settings

OSD Time/ Text – The time stamp and channel name displayed on the screen.

Include Time Include Text:
 OSD Position: OSD Opacity: OSD Color:

GXV3611 Networking Page – Assign an IP to GXV3611

GXV3611 supports IP version 4. The IP address can set automatically via DHCP, or a static IP address can be set manually. To make GXV3611 work properly, the user needs to set the DNS configuration properly. For security purposes, the user can also assign the GXV3611 an HTTP Port other than 80.

IP Address Configuration

The GXV3611 operates in two modes:

Dynamically Assigned via DHCP – all the field values for the Static IP mode are not used. The GXV3611 acquires its IP address from the first DHCP server it discovers on its LAN.

Statically Configured as – configures all of the following fields: IP address, Subnet Mask, Default Gateway IP address, DNS Server 1 (primary), DNS Server 2 (secondary). These fields are set to zero by default. *Static IP addresses are recommended for the GXV3611*

IP Address Configuration

Dynamically Assigned via DHCP
 Statically Configured as:
 IP Address:
 Subnet Mask:
 Default Gateway:

DNS Configuration

There are two methods of DNS configuration on the GXV3611:

DNS Configuration

Obtain DNS Server Address Automatically
 Use the Following DNS Server Address:
 Primary DNS Server:
 Secondary DNS Server:

1. The GXV3611 can obtain the DNS server automatically
2. Users can configure their own preferred DNS server

HTTP Port

The GXV3611 supports user configured http ports.

If the HTTP port is changed, the port number is needed to access the web GUI, for instance:

<http://192.168.1.168:8080>.

HTTP

HTTP Port:

NOTE: If the HTTP Port is 80, when you add this device to GSurf or GS_NVR, the RTSP port is 554. If the HTTP Port is changed, when you add this device to GSurf or GS_NVR, please make sure the RTSP port number equals HTTP Port plus 2000.

GXV3611 DDNS Page

Dynamic DNS provides devices that have a variable, often changing IP address with a well known hostname resolvable by network applications through standard DNS queries.

Set up DDNS

1. Apply for a domain name from your service provider.
2. Login to the web configuration page, click **Basic Settings > DDNS**.
3. Enter the required information

Dynamic DNS Settings	
DDNS Active:	Disabled ▾
DDNS ISP Type:	dyndns.org ▾
Site Name:	<input type="text"/>
DDNS Account:	<input type="text"/>
DDNS Password:	<input type="text"/>
STUN Server:	<input type="text"/>

DDNS Active – If you want to use DDNS, please set this field to “Enabled” .

DDNS ISP Type – Select your DDNS ISP Type.

Site Name – The DDNS name for your device.

DDNS Account/ DDNS Password – The account and password from the DDNS Provider.

STUN Server – If the device is behind a router, a STUN server is needed to help penetrate the NAT.

4. Click **Save** to save the changes. You might need to reboot the device to apply all the changes.

GXV3611 SIP Page

The GXV3611 has the ability to receive phone calls and make phone calls when an alarm event is triggered through motion detection or alarm input. Register the GXV3611 to a SIP

server to enable the product to make and receive phone calls. To make outgoing phone calls out, the user needs to configure the **Phone List** properly.

Register GXV3611 to a SIP Server

1. From the GXV3611 home page, click **Basic Settings > SIP**.
2. Go to **SIP Settings** Tab.
3. Enter the required information.

Registered – The field shows the registration status of the account with the SIP server. Click **Refresh** to send out another registration.

Unregister on Reboot – The default setting is No. If set to “Yes”, the SIP user’s registration information will be cleared on reboot.

Account Name – The field configures the SIP account name.

SIP Server – The SIP Server’s IP address or Domain name provided by your service provider.

Outbound Proxy – The IP address or Domain name of the Outbound Proxy, Media Gateway, or Session Border Controller. Used for firewall or NAT penetration in different network environments. If the system detects a symmetric NAT, STUN will not work. ONLY

outbound proxies can provide a solution for a symmetric NAT.

SIP User ID – User account information provided by your service provider (ITSP); this is either an actual phone number or is formatted like one.

Authenticate ID – The SIP service subscriber’s Authenticate ID used for authentication. It can be identical to or different from the SIP User ID.

Authenticate Password – The SIP service subscriber’s account password for the GXV to register to the SIP server of the ITSP.

STUN Server – If the device is behind a router, a STUN server is needed to help penetrate the NAT.

Registration Expiration – This parameter allows users to specify the time frequency (in minutes) in which the GXV refreshes its registration with the specified registrar. The default interval is 60 minutes.

Local SIP Port – This parameter defines the local SIP port used to listen and transmit. The default value is 5060.

Local RTP Port – This parameter defines the local RTP-RTCP port pair that is used to listen and transmit. The default value is 5004.

4. Click **Save** to save all the changes. You need to restart the device to apply all changes.

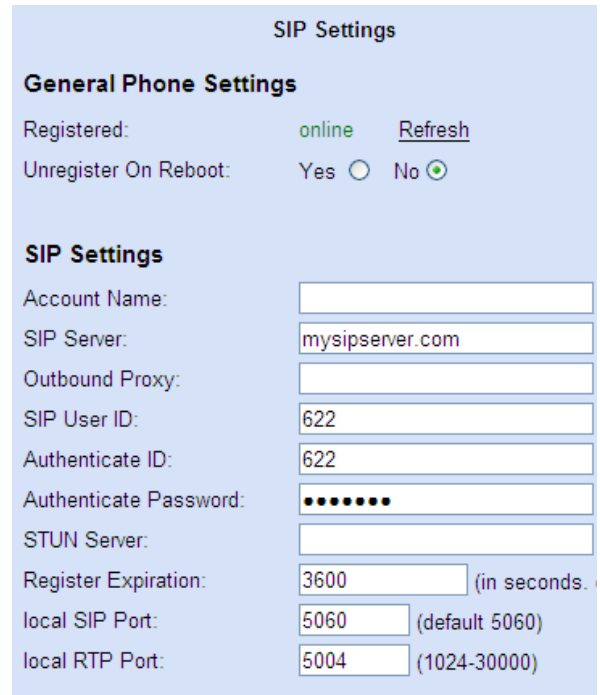

SIP Settings

General Phone Settings

Registered: online [Refresh](#)

Unregister On Reboot: Yes No

SIP Settings

Account Name:

SIP Server:

Outbound Proxy:

SIP User ID:

Authenticate ID:

Authenticate Password:

STUN Server:

Register Expiration: (in seconds)

local SIP Port: (default 5060)

local RTP Port: (1024-30000)

Configure *Phone List* Page

To make sure the GXV3611 can make phone calls to the number you preferred when alarm is triggered. You need to add number to the phone list.

Steps to add phone number:

1. From the GXV3611 home page, click **Basic Settings > SIP**.
2. Go to **Phone List** Tab.
3. Enter the **Phone number** and **name**, click **Add a Number** to save all the changes.
4. Numbers added to the system will be listed in this page.

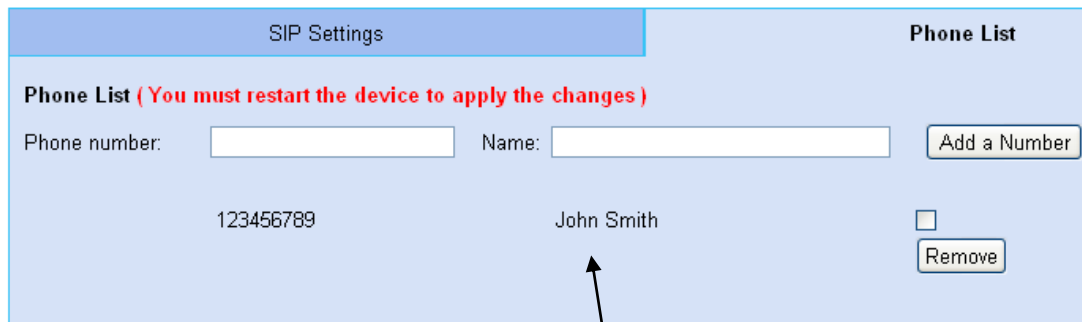

Available phone numbers

NOTE: With current firmware, only the first phone number in the list will be called when an alarm is triggered.

GXV3611 Date & Time Page

This page allows you to configure the system time on GXV3611.

Current System Time - displays the current date and time (24h clock).

Set the Device Time

Update via NTP Server - the camera will obtain the time from an NTP server. Specify the NTP server's IP address or host name. And you can select your time zone from the drop-down list or define your own time zone setting.

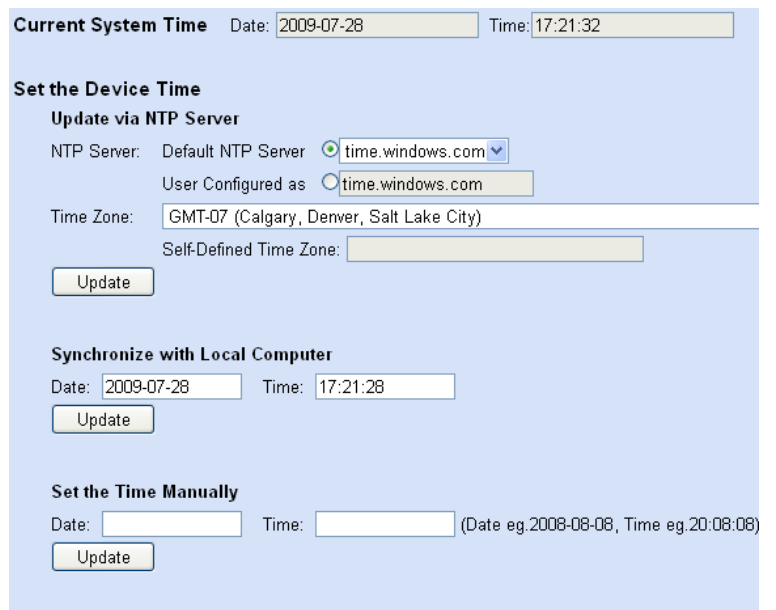

NOTE: If using a host name for the NTP server, a DNS server must be configured under

Basic Settings > Networking.

Synchronize with Local Computer - sets the time from the clock on your computer.

Set the Time Manually - this option allows you to manually set the time and date.

GXV3611 Maintenance Page**Server Maintenance**

Restart – Click this button to restart the GXV3611.

Restore – Click this button to perform a partial factory reset (The IP address will not be cleared) .

Server Maintenance

Restart	Restart the device.
Restore	Reset settings, except IP address, to factory default.

Firmware Upgrade and Provisioning Items

Upgrade via – This field lets you choose the firmware upgrade method. The GXV3611 supports HTTP, HTTPS and TFTP.

Firmware Server Path – The IP address or domain name of the firmware server (the location of the firmware files) .

Automatic Upgrade Interval – Enter the frequency (in minutes) in which the HTTP/HTTPS/TFTP server will be checked for new firmware upgrades or configuration changes.

Automatic Upgrade – The default setting is “No.” Choose “Yes” to enable automatic HTTP/HTTPS/TFTP upgrade and provisioning. When set to “No”, the IP Camera will only perform a HTTP/HTTPS/TFTP upgrade and perform a configuration check once during the boot process.

Firmware Upgrade and Provisioning

Upgrade via :	HTTP
Firmware Server Path :	my.firmwai
Automatic Upgrade Interval :	10080
Automatic Upgrade :	<input checked="" type="checkbox"/> YES

Performing a firmware upgrade:

1. Download the firmware package from <http://www.grandstream.com/firmware.html>.
2. Unzip the firmware package and copy the files to the firmware upgrade server directory.
Upgrades are supported via TFTP, HTTP and HTTPS.
3. Log in to the **Maintenance page** of the GXV3611. Select the server type from the dropdown list under the “Upgrade Via” field. Enter your server’s root directory in the “Firmware Server Path” field.
4. Reboot the GXV3611 to begin the firmware upgrade process.

GXV3611 Administrator Page

All current users will be list in the User List section of this page. You can also add and remove users here.

User List

The field lists all of the current users. You can insert or remove users from the list by click on the **Add** or **Delete** button.

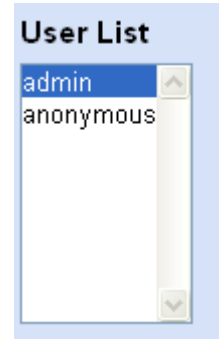

Allow Anonymous Login

If 'Allow Anonymous Login' is set to Yes, no user name and password are required to login to the GXV3611 web configuration pages.

If you login anonymously, you will not be able to change any settings.

Camera Name Settings

This field lets you configure the name of the GXV3611, which helps GSurf and GS_NVR to indentify the device when using **GS_Search** to search all the Grandstream network cameras or digit video cameras in the same subnet.

GXV3611 Change Password Page

Changing the default password is strongly recommended for security purposes. To change the password, go to **Change Password** page; enter **Current Password, New Password** and Confirm New Password; Click **Save** to save all the changes.

A window will appear with a prompt for a new password. Enter the user name and new password to re-log into the web configuration pages.

GXV3611 SMTP Page

The SMTP server is used to send out emails when an alarm event or motion detection is triggered. The SMTP settings must be configured to make sure the alarm email is sent out properly.

SMTP Server Settings

Enable SMTP – The default setting is “No.” If you want the GXV3611 to send out emails with the captured image when an alarm is triggered, set this field to “Yes.”

SMTP Server – The IP or hostname of the SMTP server, for example, smtp.gmail.com.

SMTP Server Settings

Enable SMTP: Yes No

SMTP Server: Port:

From E-Mail address:

To E-Mail address:

This server requires a secure connection(SSL): Yes No

User Name:

Password:

Test Email Account Settings:

1 Required Fields.
2 Valid DNS server is required for hostname.

Port – The port of the SMTP server. The GXV3611 supports port 25 and SSL port 465, which is for SMTP with an encrypted connection.

From E-Mail Address – The email address that sends out the alarm email(s).

To E-Mail Address – The email addresses that the alarm email(s) will be sent to. You can have up to 3 emails configured.

This server requires a secure connection (SSL) – Set this field to Yes if the SMTP server requires a secure connection.

User Name/ Password – The user name and password required to log in to your SMTP server, for example, 123@gmail.com/123.

Test Email Account Settings – Click the Test button to send a test email from the *From E-Mail* to the *To E-Mail* to make sure that SMTP is configured properly. If the receiver can get the test email, then the SMTP settings are ready to go.

GXV3611 FTP Page

The FTP server is used to store video files if you configure the GXV3611 to record video and upload it to the FTP server when an alarm event or motion detection is triggered.

FTP Settings

Enable FTP – The default setting is “No,” if you want the GXV3611 to upload the recorded video to the FTP server when an alarm is triggered, set this field to “Yes.”

FTP Server – The IP address or hostname of the SMTP server, ie. ftp.myserver.com.

Port – The port that your FTP server is using.

User Name / Password – The user name and password required to log into your FTP server

Path – The directory in the FTP server where recorded video will be uploaded.

Test FTP Account Settings – Click the Test button to upload a sample file to make sure that FTP is properly configured.

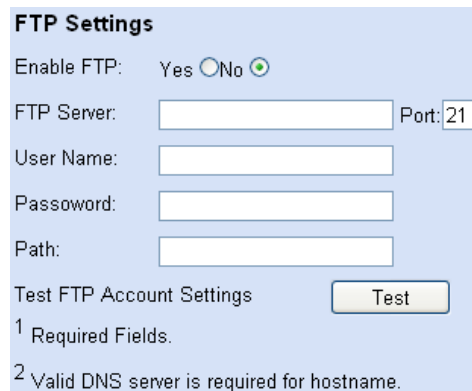

GXV3611 Alarm Event

The GXV3611 supports alarm inputs, for example, infrared detector, smoke detector and so on.

Follow the steps to make Alarm Input work:

1. Connect alarm input equipment to the GXV3611.
2. Set up the alarm event time schedule.

3. Configure the alarm actions which you would like the GXV3611 to take when alarm is triggered.

Note: The smoke detector in the GXV 3611 mini dome camera is not intended to replace any smoke detector alarm system. The smoke detector does not comply with the National Alarm and Signaling Code, nor does it provide any form of visual or audible signal to alert the premises dwellers. You must not replace any existing smoke alarm system with this product.

How Alarm Input and Alarm Output Work

Alarm-in is the alarm input port; users are able to connect sensors such as infrared sensor, smoke sensor or light sensor to it. The detectable signal voltage range for alarm-in is from 1.8V to 15 V **NOTE:** Please do not connect a device that has a signal voltage that is higher than 15V, this will damage the IP camera.

Internally, the Alarm-out uses relays as a switch (30VAC/2A); users can connect devices such as alarm siren or alert light to this port. Under normal circumstances, the circuit is open. When there is an alarm event, the GXV3611 will close the circuit to trigger the alarm.

Connect Alarm Input Equipment to the GXV3611

Here are two sample connection diagrams. Connect the alarm equipment to the GXV3611 by following the diagram below.

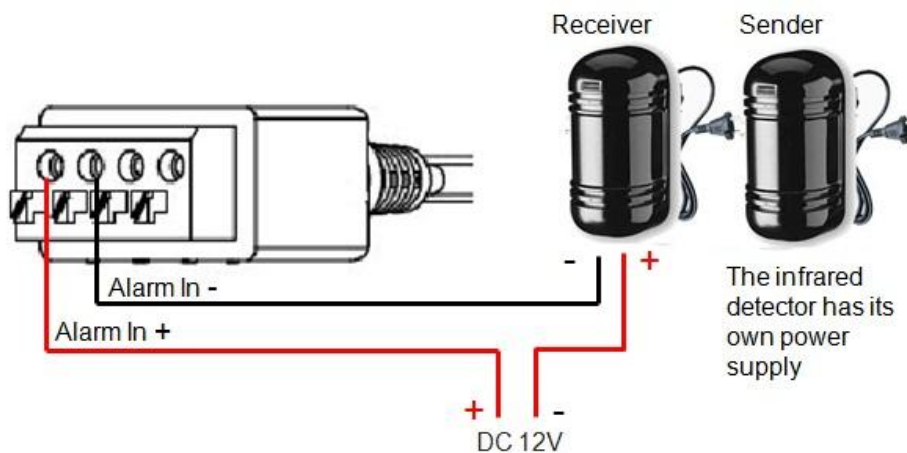

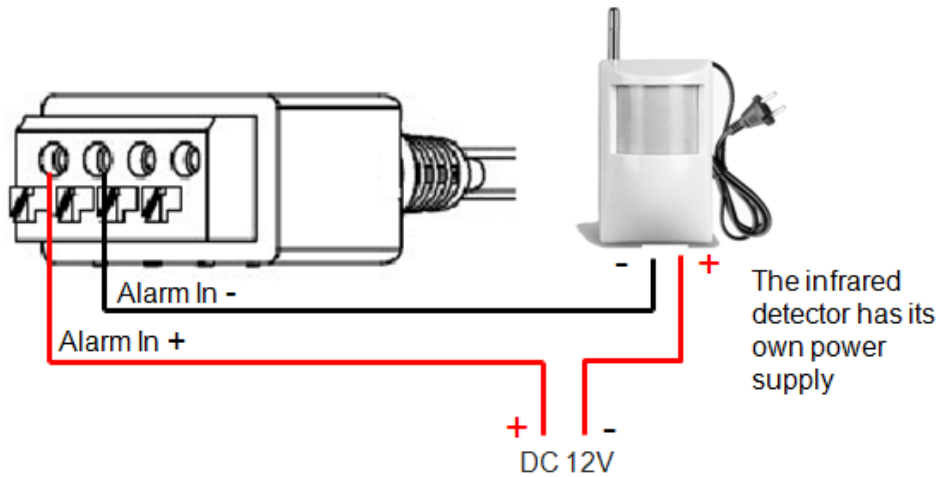

Set up Alarm Event Time Schedule

This section allows you to configure the time during which the GXV3611 will monitor the Alarm Input. The GXV3611 can not only monitor your settings but can also take actions when the alarm is triggered.

Dropdown list for date Available time schedules

Alarm Event Time Schedule

Start Time: : End Time: :

Date	Start Time	End Time	Remove
Tuesday	00:00	23:59	<input type="checkbox"/>
Saturday	00:00	23:59	<input type="checkbox"/>

Select All:

To add a schedule, select the **date** from the dropdown list, **Start Time** and **End time** and Click **Add** to add a new time schedule.

To delete a schedule, check the schedule you would like to remove and click **Delete**.

Set up Alarm Actions

An alarm action is what the GXV3611 is going to do when an alarm is triggered during the defined time period – the time schedule. The GXV3611 allows multiple alarm actions.

Record Video – If this option is selected, the GXV3611 will

Alarm Action

Record Video From Pre Alarm seconds to After Alarm seconds

Choose a Storage Method:

SD Card USB Flash Drive

Voice Alarm to SIP Phone

Alarm Output.

Upload to Alarm Center.

Record Video and Upload to FTP Server.

Email JPEG and Store it to USB card or SD drive.

record the video when an alarm is triggered. You can enter the length of the video recording (in seconds). You can also choose the storage method for video files: SD card, USB Flash drive, or USB hard drive.

Voice Alarm to SIP Phone – If this option is selected, the GXV3611 will make calls to the number listed in the **Phone List** page using the configured SIP account when an alarm is triggered. To use this function, the settings in **SIP** page must be configured properly.

Alarm Output – If this option is selected, the alarm will output via the configured method/equipment when it is triggered.

Upload to Alarm Center – This option is an integrated feature with GSurf. If this option is checked, the GXV3611 will report the alarm event to GSurf.

Record Video and Upload to FTP server – If this option is selected, the GXV3611 will record the video and upload it to the FTP server when an alarm is triggered. You must check Record Video and configure the FTP page properly to use this feature.

Email JPEG and Store it to USB drive or SD card – If this option is selected, the GXV3611 will capture the image and store it to connected live storage device when an alarm is triggered.

How to connect an Alarm Output Equipment to GXV3611

Here is a sample connection diagram. Connect the alarm output equipment to the GXV3611 by following the diagram below.

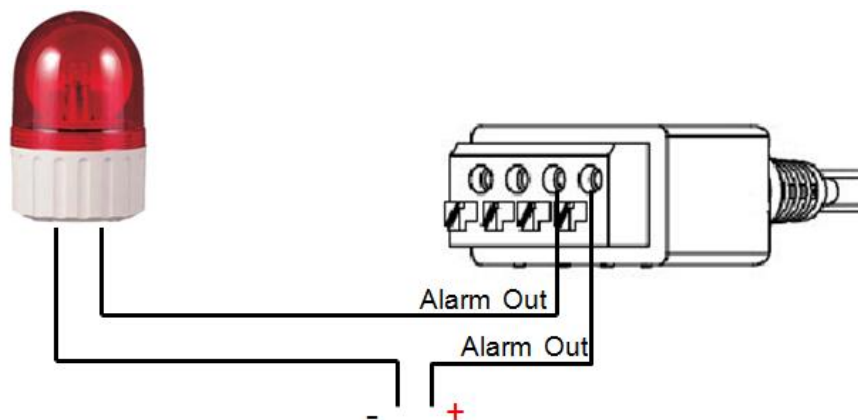

GXV3611 Motion Detection

The GXV3611 supports Motion Detection. To utilize this feature, please follow the below steps:

1. Setup the motion detection monitored area.
2. Configure the motion detection time schedule.
3. Configure alarm action properly.

Setup Motion Detection Monitored Area

Enable Motion Detection – If this option is selected, motion detection will be enabled. If

something/somebody moves in the motion detection region, an alarm will be triggered.

Show Motion Detection Regions – If this option is selected, the motion detection regions will be displayed on the screen with a white border.

The white border for Motion Detection Regions



NOTE: If **Upload to Alarm center** is checked for **Alarm Actions**, the white border will **flash red** when a motion detection alarm is triggered.

To Edit a Monitored Area

1. In the **Select a Region** dropdown list, select the region ID.
2. Click **Edit**.
3. Click on the video, drag and draw you preferred area.
4. Set the Sensitivity. Click the **Save** button to save the sensitivity.

NOTE: The Sensitivity value varies from 0 to 100. The larger the value is, the higher the sensitivity.

5. Click **Save** to save the settings.

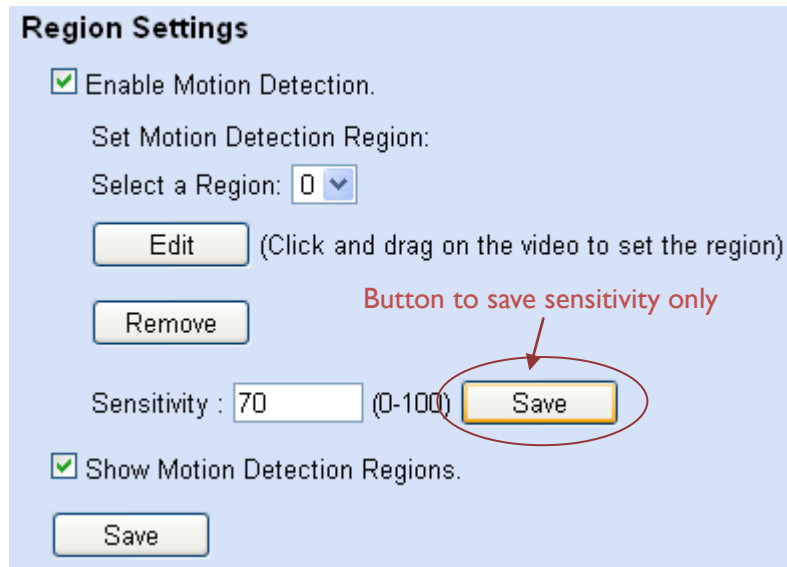

To Remove a Monitored Area

1. In the **Select a Region** dropdown list, select the region you would like to remove.
2. Click **Remove**.
3. Click **Save** to save the changes.

Configure Motion Detection Time Schedule & Alarm Actions

For more detailed information, please refer to the **Time Schedule** and **Alarm Actions for Alarm Event**.

GXV3611 System Log

This page is used to set up the system log server path and system log level. Once they are correctly configured, the device will send out system log messages to the system log server, which will help perform troubleshooting.

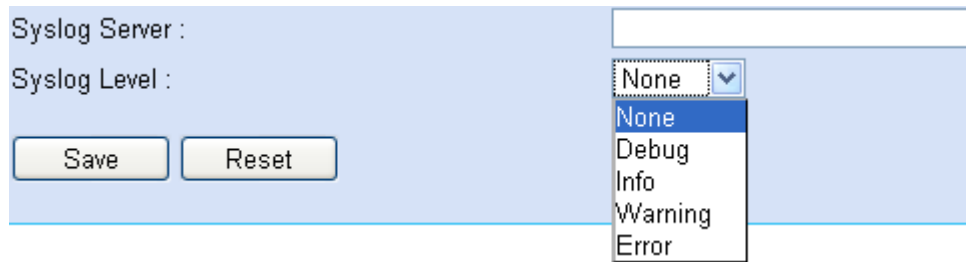

The screenshot displays a configuration panel for system logging. It includes a text input field for the Syslog Server address, a dropdown menu for the Syslog Level (currently set to 'None'), and two buttons labeled 'Save' and 'Reset'.

Syslog Server – The IP address or URL of System log server.

Syslog Level – Select the device to report the log level. Default is None. The level is one of Debug, Info, Warning or Error.

IP VIDEO SURVEILLANCE FAQ

1. What is the default IP address of GXV3601/3501/3504/3611?

The IP address of GXV3501/ 3504/ 3601/ 3611 is 192.168.1.168 at the factory default settings. You can perform a factory reset by pressing the RESET button on the device for 7 seconds.

2. Why can I not view the live video stream in Microsoft Internet Explorer?

Please check whether the IE add-on is installed correctly.

Once you log into the GXV3501/ 3504/ 3601/ 3611's web interface Internet Explorer will indicate that "This website wants to install to following add-on: 'GSViewer. cab' from Grandstream Networks, Inc.". Please install this add-on when prompted by IE.

3. How do you manually uninstall the Grandstream video viewer add-on for IE?

Please follow these steps to uninstall the add-on:

1. Delete the *GSViewerX Control* from *C:\WINDOWS\Downloaded Program Files* directory
2. Delete *GSNetClient.dll*, *GS_Replay.exe*, *GSViewerX.ocx*, *hi_h264dec_w.dll*, *lik_VoiceEngine_dll.dll* and *GSViewerX.inf* from *C:\WINDOWS\system32*

4. Why can't I access the GXV3501/ 3504/ 3601/ 3611 web configuration interface?

Q 1: Is your internet service down?

A 1: Connect a PC to the internet to test the connection.

Q 2: Are the PC and the device in different subnets?

A 2: Check the subnet mask and default gateway of the device and PC.

Q 3: Is there a conflict with another IP address?

A 3: Try to change the IP address of the device.

Q 4: Has the HTTP port been changed?

A 4: Contact the administrator of the device for more information.

5. The GXV3501/ 3504/ 3601/GXV3601/GXV3611 web configuration page is not displayed correctly in Internet Explorer 8?

In IE8, Compatibility View might need to be enabled for the GXV3501/ 3504/ 3601/ 3611 web configuration page to load properly. To enable compatibility view, open IE8, click *Tools*, *Compatibility View Setting*, and add the GXV3501/ 3504/ 3601/ 3611 web configuration pages to the Compatibility View.

6. Why does IE indicate to install Grandstream Video Viewer add-on after a firmware upgrade? The add-on was properly installed before the firmware upgrade process.

New firmware will often upgrade the add-on as well. To watch the live video stream, you must install the newest version of the add-on.

7. How do you watch secondary video stream?

Login to the home page of the GXV3501/ 3504/ 3601/ 3611 web GUI, click Play to watch the video stream. To watch a secondary video stream, right click on the video, and select *Secondary Stream* on the pop-up menu. Try reinstalling the Grandstream Viewer add-on for IE if you cannot see the video stream.

8. Why is audio missing from the recorded video when an alarm is triggered?

Please double check whether the device has an audio input connected.

The GXV3504 has 4 audio input ports and one MIC IN port. The GXV3501 has a MIC IN port for an audio input. The GXV3601/3611 has a built-in microphone and one MIC IN port for audio inputs.

9. What is DDNS? Is it important for IP surveillance product to have DDNS support?

DDNS is an acronym for Dynamic Domain Name Service. It is important to choose an IP network camera that has DDNS support for dynamic IP addresses.

Chances are that the network has a dynamic IP address (which changes with every log on). A DDNS service makes sure that the camera's IP address always matches up to the current server address. DDNS also allows for a website to be linked to the IP camera that is constantly updated with the correct information and has a reliable feed.

10. Why is Windows Media Player unable to play the recorded videos files?

The GXV3501/ 3504/ 3601/ 3611 all use the H.264 video codec. Windows Media Player may lack the proper H.264 decoder to play the recorded video. Please download the Microsoft FFDSHOW H.264 decoder from <http://sourceforge.net/projects/ffdshow-tryout/> and install it.

11. Alarm Triggered Events do not work in GSurf.

Please double check the Alarm Action on your GXV3501/ 3504/ 3601/ 3611. Login to the web GUI of the GXV3501/ 3504/ 3601/ 3611, go to the *Motion Detection* or *Alarm Events* page, and make sure option *Upload to Alarm Center* is checked.

12. It is recommended that you save your video files in different directories when using GSurf and GS_NVR.

GSurf and GS_NVR are different programs that have the ability to delete recorded video files. It is better to save video files in different directories when using GSurf and GS_NVR in the event that they automatically delete files that you might want to keep.

13. How can I use a cell phone to watch the GXV3501/ 3504/ 3601/ 3611 video stream?

You must set the video resolution to QCIF to watch the GXV3501/3504 /3611 video stream

from a cell phone. Make sure to set the bit rate to 64kbps to ensure the best video quality.

14. Why doesn't the IP address of the device reset when I click the "Restore" button on the Maintenance page?

The GXV3501/ 3504/ 3601/ 3611 could be installed in areas that are not easy to access. For example, it could be installed on the roof of a building or the ceiling of an office. This makes it difficult to reinstall the device, therefore the "Restore" function will not clear the IP address. Press the RESET button on the device for at least 6 seconds until you hear a beep to perform a factory reset of all parameters (including the IP address).

15. Why can't the live video stream be viewed using a mobile phone or GSurf after changing the HTTP Port of the device?

Make sure that the RTSP port of the device is set to 2000 plus the HTTP Port number. For example, if the HTTP port is 88, then the RTSP port of the device that you configured on GSurf / mobile phone should be 2088.

16. Some notes when using SD cards / USB drives.

- NOTE:**
1. The GXV3501/ 3504/ 3601/ 3611 only supports FAT32 formatted USB drives
 2. The GXV3501/ 3504/ 3601/ 3611 support SD and SDHC
 3. It takes 10-15 seconds to read SDHC and USB drives with large memory capacities.

Please wait 15 seconds to unplug the SD/USB drive after you plug them into the device.

4. If there are many files (ie. 1800 or more image batch files) on the SD/USB drive, it can take up to 5 minutes to read them. Please do not refresh the web interface at this time as the GXV3501 /3504 /3611 will restart reading the SD/USB drive. Grandstream is currently working on a fix for this issue.

17. Why is there a black / flashing bar at the bottom of the video feed?

This can occur if the GXV3501 /3504 does not recognize the standard of the connected camera. If you experience this issue, please restart the GXV3501 /3504. The GXV3501 /3504 will detect the standard of the connected camera and use it when the GXV3501 /3504 boots up. To avoid this make sure to connect analog cameras before booting up the GXV3501 /3504.

18. Port forwarding

Two ports must be forwarded on your router to watch video from a GXV3501 /3504 /3611 that is located on a private network from a PC in a public network. The web port (HTTP) and the RTSP port. Please make note that the RTSP port number changes according to the web port. If the web port is 80, then the RTSP port is 554. If the web port is not 80, then the RTSP port equals the web port +2000. For example, if the web port is 88, then the RTSP port will be 2088.

19. Tested PC display adapters.

<i>Display Adapter</i>	<i>Test Result</i>
SiS 650/651/740/661 FX/741/760 Series	Works normally
Intel(R) 82945R Express Chipset Family	Works normally
VIA/S3G UniChrome Pro IGP	Works normally
NIVDIA Geforce 7300GS	Works normally
SiS 661FX	Works normally
SiS Mirage Graphics	Works normally
SiS 661 Series	Works normally
Intel(R) G33/G31 Express	Works normally
SiS Mirage3 Graphics	Works normally
SiS 661FX/GX Mirage Graphics	Works normally
S3 Graphics ProSavageDDR(Microsoft Corporation)	Works normally
XGI Velari Z7/Z9/Z9S V1.08.12	There is some delay when playing videos.
Intel 965 Express Chipset Family	Works normally
ATI Mobility Radeon X1300	Works normally
Intel(R) G45/G43 Express Chipset	Works normally
Mobile Intel 965 Express Chipset Family	Works normally
Mobile Intel(R) 4 Series Express Chipset Family	Works normally
Mobile Intel® 945GM Express Chipset Family	Works normally
Mobile intel® 915GM/GMS, 910GML Express Chipset Family	Works normally
Intel® G45/G43 Express Chipset	Works normally
ATI Technologies, RAGE XL PCI	This display adapter cannot display videos.