

Jun

| 14

# User Manual DVH4013

## **Three Phase Electronic Electricity Meter**

for

## **DIN Rail-Assembling**

Date	11.06.2014
Last changes	17.03.2015



DZG Metering GmbH, Heidelberger Str. 32, D-16515 Oranienburg



The contents of this user manual are copyright reserved.

Translations, prints and copies are only allowed authorized by DZG.

All mentioned brand names and product names are ownership of DZG Metering GmbH.

Contents may be completed, changed or deleted without prior announcements.

The descriptions of this user manual are not integral part of contracts.





© DZG Metering GmbH All rights reserved.

DZG Metering GmbH  
Heidelberger Str. 32  
D-16515 Oranienburg

**Notice:**

This manual describes electricity meters of the type DVH4013. It includes all necessary informations for assembling, setting into operation and use of the meter.

**Used Symbols**

	<p><b>Danger through Electric Voltages</b> The symbol indicates warnings, which may lead to personal injuries or death if it is ignored. Take all necessary precautions to avoid danger !</p>
	<p><b>Warning</b> The symbol indicates warnings to a possible dangerous situation which may lead to personal injuries or damage to properties. Avoid dangerous situations !</p>
	<p><b>Attention!</b> „Attention“ indicates warnings, which may lead to damage of properties if not observed.</p>
	<p><b>Notice</b> „Notice“ indicates important information in the manual.</p>
	<p>The symbol is printed on the nameplate and references to further informations in a instruction manual prepared for the customer.</p>



## Content

<b>1</b>	<b>Properties</b> .....	<b>7</b>
1.1	<b>Common</b> .....	<b>7</b>
1.2	<b>Properties</b> .....	<b>7</b>
1.3	<b>Technical Standards</b> .....	<b>8</b>
<b>2</b>	<b>Safety</b> .....	<b>9</b>
2.1	<b>Responsibility</b> .....	<b>9</b>
2.2	<b>Common safety instructions</b> .....	<b>9</b>
2.3	<b>Service- and warranty instructions</b> .....	<b>9</b>
2.4	<b>Disposal (product end of life information)</b> .....	<b>9</b>
2.5	<b>Environment</b> .....	<b>9</b>
2.6	<b>Service and Warranty</b> .....	<b>9</b>
<b>3</b>	<b>Typecode</b> .....	<b>10</b>
<b>4</b>	<b>Assembling and Installation</b> .....	<b>11</b>
4.1	<b>Assembling</b> .....	<b>11</b>
4.2	<b>Installation</b> .....	<b>12</b>
4.3	<b>Protection Housing</b> .....	<b>14</b>
4.4	<b>Terminals for extern tarif control</b> .....	<b>14</b>
<b>5</b>	<b>Firmware</b> .....	<b>15</b>
<b>6</b>	<b>Nameplate</b> .....	<b>15</b>
<b>7</b>	<b>LCD-Display</b> .....	<b>16</b>
<b>8</b>	<b>User Buttons</b> .....	<b>17</b>
<b>9</b>	<b>RS485 Interface</b> .....	<b>17</b>
<b>10</b>	<b>Test LEDs</b> .....	<b>17</b>
<b>11</b>	<b>Components</b> .....	<b>18</b>
11.1	<b>Blockdiagramm</b> .....	<b>18</b>
11.2	<b>Real time clock (RTC)</b> .....	<b>18</b>
11.3	<b>S0-Pulse Output</b> .....	<b>19</b>
<b>12</b>	<b>Functionality</b> .....	<b>20</b>
12.1	<b>Measurement</b> .....	<b>20</b>
12.2	<b>Firmware Architecture</b> .....	<b>20</b>
12.3	<b>Energy Checksum Mechanism</b> .....	<b>21</b>
12.4	<b>Self Monitoring</b> .....	<b>21</b>
12.5	<b>Additional Registration Functions</b> .....	<b>21</b>
12.5.1	Demand channel .....	21
12.5.2	History data record .....	22
12.5.3	Instantaneous parameter measurements .....	22
12.5.4	Load profile .....	22
12.6	<b>Display Modes</b> .....	<b>23</b>
12.6.1	Status Diagramm .....	23
12.6.2	AUTO Mode and ALT Mode.....	24
12.6.3	TEST Mode .....	24
12.6.4	Second index .....	25
12.6.5	Security functions.....	25
12.6.6	Fatal Error .....	25
<b>13</b>	<b>Registers</b> .....	<b>26</b>
13.1	<b>Instantaneous data</b> .....	<b>26</b>
13.2	<b>Basic Parameter</b> .....	<b>26</b>
13.2.1	Status Register .....	27



<b>13.3</b>	<b>Tarif rate and Demand intervall .....</b>	<b>27</b>
<b>13.4</b>	<b>Load Profile Parameter.....</b>	<b>28</b>
<b>13.5</b>	<b>Display Settings.....</b>	<b>28</b>
<b>13.6</b>	<b>Energy Register.....</b>	<b>29</b>
<b>13.7</b>	<b>Maximum Demand Register .....</b>	<b>35</b>
<b>13.8</b>	<b>Logging Register .....</b>	<b>43</b>
13.8.1	Logging Demand Resets .....	43
13.8.2	Logging Power Outages .....	44
13.8.3	Logging Clock Synchronisation .....	45
<b>13.9</b>	<b>Accuracy Test.....</b>	<b>46</b>
<b>14</b>	<b>Manufacturing.....</b>	<b>46</b>
<b>15</b>	<b>EG-Declaration of Conformit .....</b>	<b>47</b>

## Tables

<b>Tab. 1:</b>	<b>Technical Properties .....</b>	<b>8</b>
<b>Tab. 2:</b>	<b>Typecode .....</b>	<b>10</b>
<b>Tab. 3:</b>	<b>Terminal block .....</b>	<b>13</b>
<b>Tab. 4:</b>	<b>Terminals tarif control.....</b>	<b>14</b>
<b>Tab. 5:</b>	<b>Description Nameplate.....</b>	<b>15</b>
<b>Tab. 6:</b>	<b>Display Elements .....</b>	<b>16</b>
<b>Tab. 7:</b>	<b>User Buttons .....</b>	<b>17</b>
<b>Tab. 8:</b>	<b>Load Profile Channels .....</b>	<b>22</b>
<b>Tab. 9:</b>	<b>Format/Unit Displayed Values.....</b>	<b>24</b>
<b>Tab. 10:</b>	<b>Display Lists.....</b>	<b>24</b>
<b>Tab. 11:</b>	<b>Instantaneous Data .....</b>	<b>26</b>
<b>Tab. 12:</b>	<b>Basic Parameter .....</b>	<b>26</b>
<b>Tab. 13:</b>	<b>Status Register .....</b>	<b>27</b>
<b>Tab. 14:</b>	<b>Basic Parameter .....</b>	<b>27</b>
<b>Tab. 15:</b>	<b>Load Profile Parameter .....</b>	<b>28</b>
<b>Tab. 16:</b>	<b>Display Settings .....</b>	<b>28</b>
<b>Tab. 17:</b>	<b>Energy Registers.....</b>	<b>35</b>
<b>Tab. 18:</b>	<b>Maximum Demand Registers.....</b>	<b>42</b>
<b>Tab. 19:</b>	<b>Logging Demand Registers.....</b>	<b>43</b>
<b>Tab. 20:</b>	<b>Logging Power Outages.....</b>	<b>44</b>
<b>Tab. 21:</b>	<b>Logging Clock Synchronisation .....</b>	<b>45</b>
<b>Tab. 22:</b>	<b>Quantity of pulses.....</b>	<b>46</b>

## Pictures

<b>Abb 1:</b>	<b>Housing .....</b>	<b>11</b>
<b>Abb 2:</b>	<b>Hosuing Dimensions .....</b>	<b>11</b>
<b>Abb 3:</b>	<b>Terminal Block (Top view/Bottom view).....</b>	<b>12</b>
<b>Abb 4:</b>	<b>Connection diagramm .....</b>	<b>12</b>
<b>Abb 5:</b>	<b>Label Protection Hosuing.....</b>	<b>14</b>
<b>Abb 6:</b>	<b>Nameplate .....</b>	<b>15</b>
<b>Abb 7:</b>	<b>LCD.....</b>	<b>16</b>
<b>Abb 8:</b>	<b>User Buttons .....</b>	<b>17</b>
<b>Abb 9:</b>	<b>Blockdiagramm.....</b>	<b>18</b>
<b>Abb 10:</b>	<b>Status digramm display modes .....</b>	<b>23</b>

## Abbreviations

+A	Import active energy (to customer)
-A	Export active energy (from customer)
dd	day
DIN	German Institut for Standards
EN	European Standard
FNN	Forum Netztechnik/Netzbetrieb im VDE
FIFO	First IN-First OUT
HH or hh	Hour
IEC	International Electrotechnical Commission
Imp/kWh	quantity of pulses each kWh
Imp/kvarh	quantity of pulses each kvarh
IR	Infrared
LCD	Liquid Crystal Display
LED	Light Emitting Diode
MM or mm	Month or Minutes
OBIS	Object Identification System
+P	Import active power
-P	Export active power
PTB	Physikalisch Technische Bundesanstalt
+Q	Import reactive Power
-Q	Export reactive Power
RTC	Real Time Clock
+R	Import reactive energy (inductive)
-R	Export reactive energy (kapacitive)
SS or ss	Seconds
TOU	Time Of Use
Tx	Tariff (z.B. T1 Tariff1, T2 Tariff2, ...)
VDE	Association of Electrotechnic/Elektronik/Informationstechnik e.V.
yyyy	Year



# 1 Properties

## 1.1 Common

Welcome to use this three phase Din Rail meter. Let's introduction it's functions and operations of this product.

This meter is three phase – 4 wire direct connected electricity meter. It adopts the advanced technology of LSI (Large Scale Integrated circuit) and digital signal processing. The craftworks of our product are exquisite and the functions provided are comprehensive and client-oriented. The energy meter is an intelligent instrument equipped with leading technology.

The functionality of the single phase Din Rail energy meter includes active energy total and tariff dependant, demand measurement, instantaneous measurement for voltage, current, frequency, power factor and power, RS485 communication, anti-tamper protection and event record, power quality detection, load profile, pulse output for test, self check.

Appropriate Use

The electricity meter DVH4013 and all versions of it are allowed to be used for measuring electrical energy only.

## 1.2 Properties

<b>Type</b>	<b>Three phase electricity meter direct connection</b>
<b>Voltage</b>	
Nominal voltage $U_n$	3x230/400 V <sub>AC</sub>
Voltage range	0.8 – 1.15 $U_n$
<b>Frequency</b>	
Nominal frequency $f_n$	50 Hz
Frequency range	0.98 – 1.02 $f_n$
<b>Current</b>	
Reference current $I_{ref} = I_b = 10 I_{tr}$	5 A
Maximum current $I_{max}$	65A
Minimum current $I_{min}$	0.25 A
Starting current $I_{st}$	$\leq 0.004 I_b$
<b>Accuracy</b>	
Cl. B	Class B in compliance with DIN EN 50470-1,-3
<b>Measuring Active Energy</b>	
Two Energy Directions	+A/-A
<b>Energy Register</b>	
Total Energie	+A and -A
Tarif Energy T1, T2, T3, T4	+A and -A
<b>Tarif control</b>	
external	Terminals 13 and 33
<b>Meter constant</b>	
LED-Output	1000 Imp/(kWh)
<b>Display</b>	
LCD	7 digit with additional symbols
Life cycle	> 12 years
<b>RS485- Data Interface</b>	
Connector	Terminals
Parameter	9.600 bps, 8E1 (setable)
Communication protocol	Modbus RTU
<b>Power Consumption</b>	



Voltage circuit	< 2 W / 10 VA at $U_n$
Current circuit	< 4 VA at $I_b$
<b>Temperature Range</b>	
Typical Operation	-25°C to +70°C
Storage	-40°C to +85°C
<b>EMC Properties</b>	
Isolation	4 kV AC, 50 Hz, 1min
High Voltage	10 kV, Impuls 1,2/50 $\mu$ s
<b>Housing</b>	
Dimension	DIN-Rail 86x35x62 mm
Material	fiber-glass reinforced Polycarbonat (flame resistant EN 62053-21, recyclable)
Class of protection	II
Degree of protection	IP 51
<b>Weight</b>	
Weight	appr. 0,5 kg

**Tab. 1: Technical Properties**

### 1.3 Technical Standards

- IEC 62053-21: Static meters for active energy (classes 1 and 2)  
 IEC 62052-11: Electricity metering equipment (AC)-General requirements, tests and test conditions – part 11: metering equipment  
 IEC 62053-31: Electricity metering equipment (AC)- Particular requirements – part 31: Pulse output devices for electromechanical and electronic meters (two wires only)  
 EN 50022: Low voltage switchgear and controlgear for industrial use; mounting rails, top hat rails, 35 mm wide, for snap-on mounting of equipment

[1] PTB Requirements:

[1.1] „Anforderungen an elektronische und software-gesteuerte Messgeräte und Zusatzeinrichtungen für Elektrizität, Gas, Wasser und Wärme“, PTB-A 50.7 2002

[1.2] „Messgeräte für Elektrizität, Elektrizitätszähler und deren Zusatzeinrichtungen“, PTB-A 20.1, Dezember 2003

[2] Legal Directives:

“Legal Metrology Guide/ general rules”, published in Federal Journal Nr 108a on June 15<sup>th</sup> 2002

[3] WELMEC-Guide 7.2, software guide



## 2 Safety

### 2.1 Responsibility

The owner or provider is responsible for the proper use of the device. The installation, putting into operation and reinstallation of the meter is only allowed to be done by electrically skilled persons, which got knowledge about the contents of this user manual.

### 2.2 Common safety instructions

For installation, setting into operation and deinstallation of the device the local requirements for safety requirements has to be observed.



#### **Danger**

Inappropriate use of parts under high voltage may lead to grave injuries and accidents, which may be fatal even with 230V.

The conductors which are connected to the device must be disconnected to the mains during assembling and installation. It must be used a prevention for being switched on accidentally.

---

The device is not allowed to be used out of specifications.

### 2.3 Service- and warranty instructions

Damaged devices can't be repaired by yourself. The warranty and liability will be terminated with opening the device. The same applies to damages caused by external influences.

For the device no servicing is required.

### 2.4 Disposal (product end of life information)



This meter was designed and built by DZG to provide many years of service, and is backed by our commitment to provide high quality support. When it eventually reaches the end of its serviceable life, it should be disposed of in accordance with local or national legislation.

### 2.5 Environment

This meter is designed for indoor use or in a cabinet environment only (avoiding extreme weather conditions) in accordance with IEC 62052-11 and IEC 62053-21, with the terminal cover fitted.

### 2.6 Service and Warranty

This meter product is warranted against defects in material and workmanship for a period of one year from date of shipment. During the warranty period DZG will at its option, either repair or replace products which prove to be defective. For warranty service or repair, this product must be returned to a service facility designated by DZG. DZG does not warrant that the operation of the meter or firmware will be uninterrupted or error free.

Damaged devices can't be repaired by yourself. The warranty and liability will be terminated with opening the device. The same applies to damages caused by external influences.

For the device no servicing is required.

### 3 Typecode

1	2	3	.	4	5	
						direct connection
DV						four-wire three-phase meter
	H40					Static meter
		13				range $I_{max} / I_{ref} = 1300\%$

DVH4013 with

- two energy directions +A/-A
- four tarif
- S0-Pulse Output

**Tab. 2: Typecode**

## 4 Assembling and Installation

### 4.1 Assembling

The meter constructed for assembling on DIN-rail TH 35-7.5 according to IEC 60715.



Abb 1: Housing

Nr	Element
1	Meter Hook
2	User Buttons
3	LCD
4	DIN Rail
5	Meter cover
6	Meter case
7	Terminal block with cover



Abb 2: Hosuing Dimensions

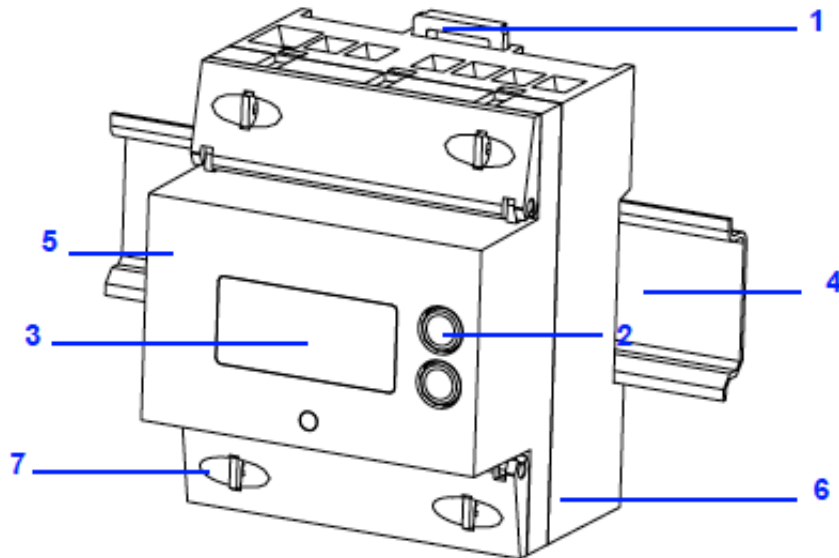

**Abb 3: Terminal Block (Top view/Bottom view)**

## 4.2 Installation

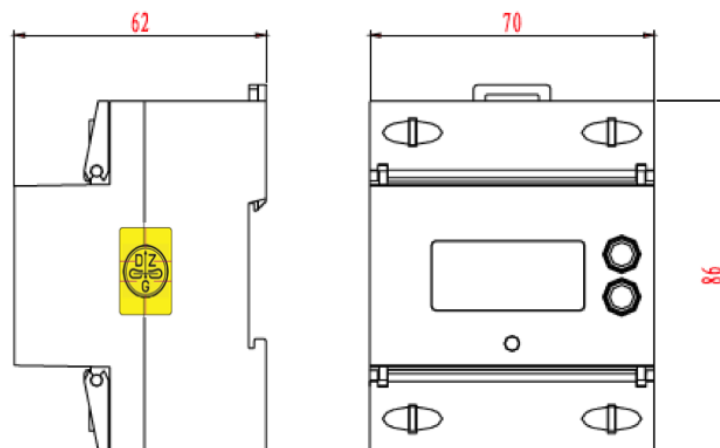
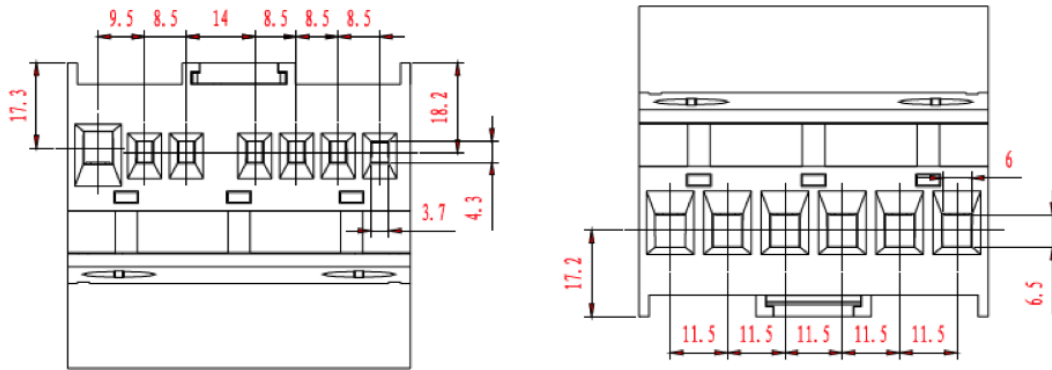
The connection diagramm printed on the housing needs to be considered connecting the meter to the mains power.

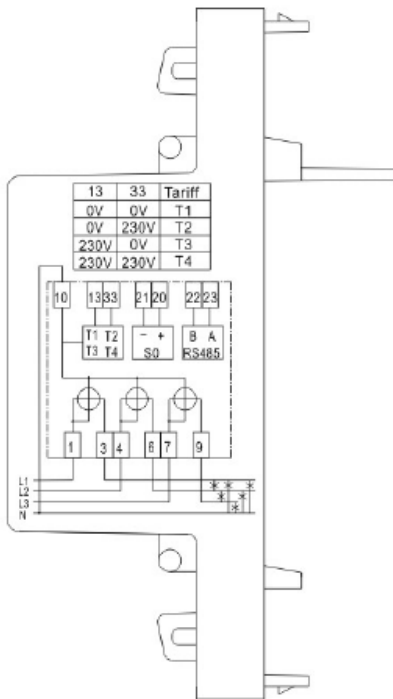

**Abb 4: Connection diagramm**

Terminal	Terminal Nr	Terminal-Ø[mm]	Terminal screw	torque M [Nm]
Current In L1	1	6,5	M4 Pozidrive PZ2	M < 2,7Nm
Current Out L1	3			
Current In L2	4			
Current Out L2	6			
Current In L3	7			
Current Out L3	9			
Voltage N	10			
external tarif control	13	4,3	M3 Pozidrive PZ2	M < 1.0Nm
	33			
S0-Output (pos voltage)	20			
S0-Output (neg. voltage)	21			
RS485 Interface B	22			
RS485 Interface A	23			

**Tab. 3: Terminal block**



### Warning

The requirements of the netprovider need to be fulfilled.  
Selective hedges has to be used according requirements of the netproviders.

### Attention!

#### Damage of the terminals due to high torque

The specified maximum torques must not be exceeded !  
Ensure that the connected lines are fixed with the needed torque compliant to EN 60999 for a safe connection. The needed torque depends on the type of used lines and the maximum current.

### 4.3 Protection Housing

The assembled meter base and meter cover will be protected against unauthorized opening with a manufacturer label (format 18x26 mm, corner radius 0,5 mm) on the side of the housing.



Abb 5: Label Protection Hosuing

### 4.4 Terminals for extern tarif control

The activation of tarif registration is done with the terminals 13 and 33 according to the following table:

terminal		activated tarif
13	33	
0 V	0 V	T1
0 V	230V <sub>AC</sub>	T2
230V <sub>AC</sub>	0 V	T3
230V <sub>AC</sub>	230V <sub>AC</sub>	T4
0V: no voltage between terminal 10 (N) and terminal 13 or 33 230V <sub>AC</sub> : phase voltage bewteen terminal 10 (N) and terminal 13 or 33		

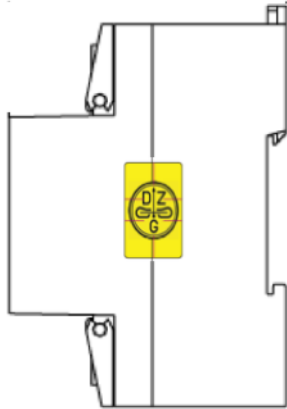
Tab. 4: Terminals tarif control

### Notice

The connection of the tarif switching unit to N is done internally in the meter.

## 5 Firmware

The firmware of the meter has the version number FW1.13 with the checksum AE40(Hex). The firmware version is displayed on the LCD.

## 6 Nameplate



Abb 6: Nameplate

Nr	Element	Function
1	terminal block with cover	sealable terminal cover
2	meter number	with barcode 128. The first two characters f.e. 14 means the year of production f.e. 2014.
3	type code	
4	user keys	Scroll up/down of the display list
5	LCD	7 digits with additional symbols
6	active tariff	the active tariffs for T3 and T4 are displayed with arrows on the LCD
7	constant S0-Pulseoutput	500 Imp/kWh
8	LED	test LED 1000 Imp/kWh
9	technical nominal data	
10	two energy directions	Import (+A) and Export (-A) energy measurement
11	protection class	
12	3 phase	
13	number approval document	
14	year of certification	CE sign, year of certification, named body for MID approval

Tab. 5: Description Nameplate

## 7 LCD-Display

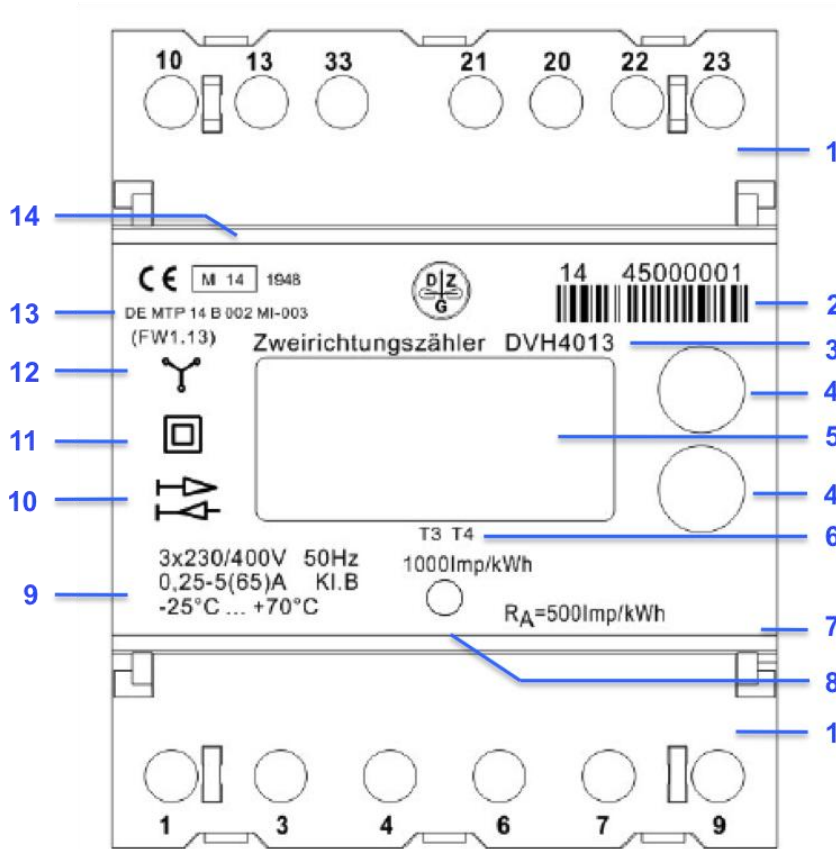
The LCD has the following format:

- LCD size: 37.5 mm × 17 mm
- Digit size: 3.38 mm × 1,53 mm



Abb 7: LCD

Nr	Element	Function
1	Unit	unit of the displayed value (kWh, kW, W, V, A)
2	values	according defined display list
3	arrows for active tarif T3 or T4	the labels T3 and T4 are printed under the LCD
4	active tarif T1 or T2	
5	indication of phase voltages	Lx < 50% Un: symbol off Lx > 120% Un: symbol is flashing
6	indication energy direction	Export Import
7	OBIS Code	Identifier of the displayed value

Tab. 6: Display Elements

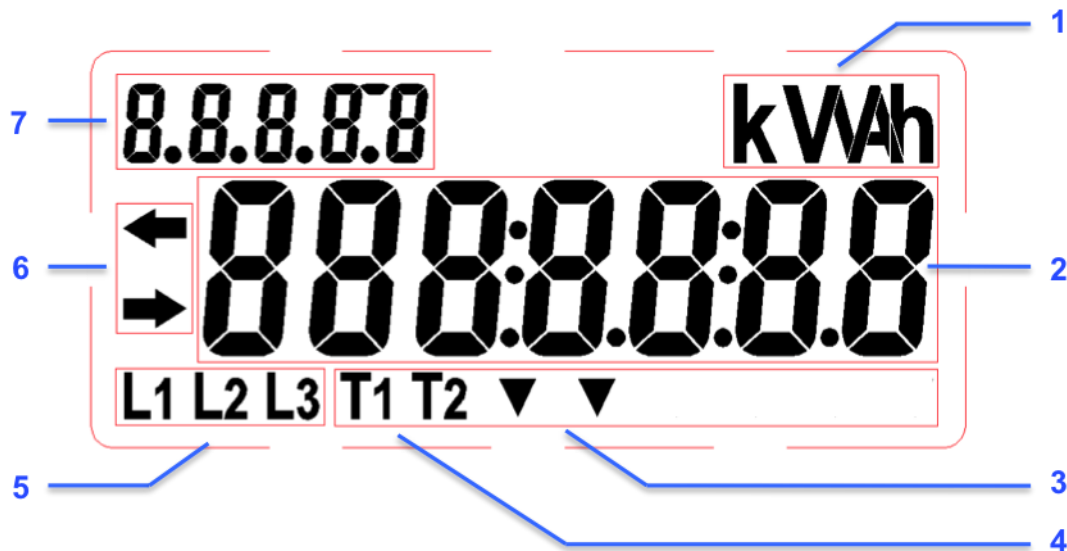

## 8 User Buttons

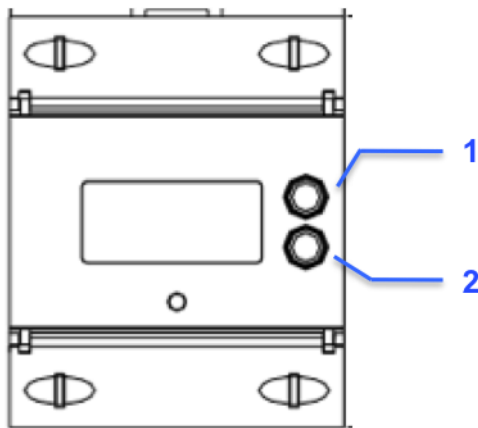

**Abb 8: User Buttons**

Nr	Element	Function
1	Button „Up“	<ul style="list-style-type: none"> <li>- Switch backlight of the LCD ON</li> <li>- Scrolling the display items</li> <li>- Enter display ALT Mode</li> </ul>
2	Button „Down“	<ul style="list-style-type: none"> <li>- Switch backlight of the LCD ON</li> <li>- Scrolling the display items</li> <li>- Enter display ALT Mode</li> <li>- Reset demand register</li> </ul>

**Tab. 7: User Buttons**

The detailed functions of the buttons to switch into the different display modes is explained under the chapter „Display-Modes“.

## 9 RS485 Interface

The interface is provided for meter reading and programming according to Modbus-RTU via RS485. The pin definition is as following:

Connection:

- Terminal 22: B
- Terminal 23: A

The Baudrate can be selected with 9600, 19200 or 38400 Bd.  
The Modbus-RTU protocol is described in an own document

## 10 Test LEDs

The meter has one pulse LED for active energy with 1000 Imp/kWh.  
The ON-time of a pulse is 40 ms.

## 11 Components

### 11.1 Blockdiagramm



Abb 9: Blockdiagramm

Current measuring:	manganin shunt
Voltage measuring:	resistor divider
A/D:	analog to digital converter for the sampled voltage and current
MCU:	Micro Controller Unit
RTC:	real Time Clock
Communication interface:	RS485-Interface
Data storage:	nonvolatile storage for energy register +A and meter parameter in EEPROM and Dataflash memory.
Display:	LCD with 7 digits and additional symbols
LED Pulse output:	active energy +A and -A, 1000 Imp/kWh
Configurable Pulse Output:	S0-Pulse Output for active energy +A, 500 Imp/kWh

### 11.2 Real time clock (RTC)

AC power and super capacitor are powering the internal clock.

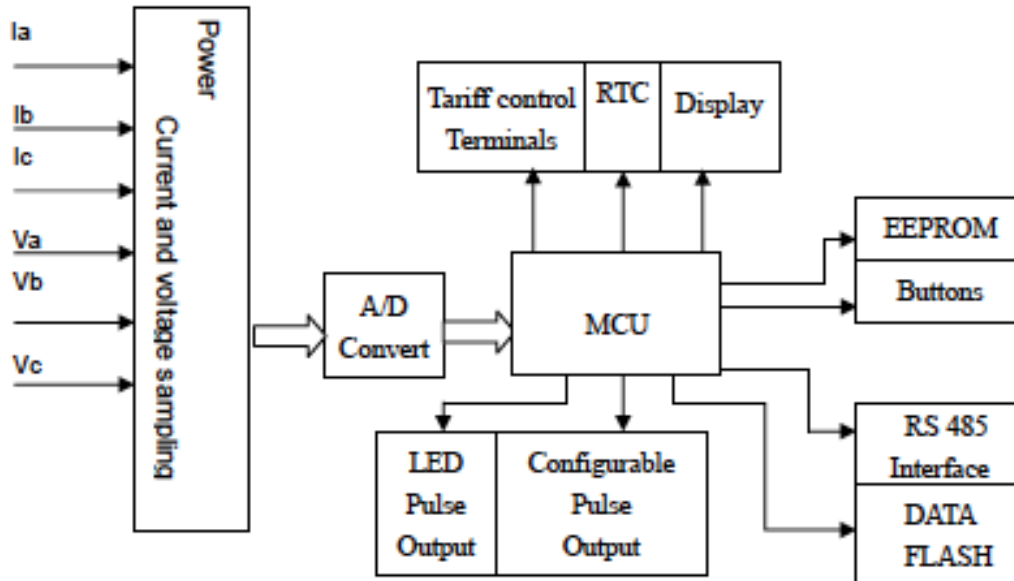
Built-in 32.768kHz quartz oscillator, frequency adjusted for high precision ( $\pm 5 \times 10^{-6}$  at ambient temperature 25 °C)



accuracy:  $<\pm 0.5 \text{ sec/day at } 23 \text{ }^\circ\text{C}$ . The variation of the time-keeping accuracy with temperature is less than  $0.1\text{s}/^\circ\text{C}/\text{day}$ ).

The RTC uses Gregorian calendar. (100years calendar including leap year).

The time and date can be set through the RS485-interface by software.

### 11.3 S0-Pulse Output

The meter provides on terminal 20 (positiv voltage) and 21 (negative voltage) a puls output for active energy +A according IEC 62053-31:

Maximum voltage:	80 V <sub>DC</sub> (standard is 27 V)
Maximum current:	60 mA (standard 27 mA)
Pulse constant:	500 Imp/kWh
Pulse duration:	80 ms



## 12 Functionality

### 12.1 Measurement

The meter measures three phase active energy for energy import +A and energy export -A with accuracy class B.

The meter provides an energy register for total energy and for each tarif T1,T2,T3 and T4 for each energy direction separately.

Additionally the total energy for each phase L1, L2 and L3 for import and export energy are measured.

The measurement of the energy is based on the measured power according the following calculations:

$$P_{total} = P_{L1} + P_{L2} + P_{L3}$$

$P_{total} > 0$ : counting energy for +A

$P_{total} < 0$ : counting energy for -A

The line current is measured with a shunt-resistors. The line-voltage is divided with resistors to a voltage level which can be measured by the A/D-converter units.

The voltages of the shunt resistor and voltage divider are measured with an A/D unit which supports the MCU with the realtime digital values for voltage and current.

The MCU calculates in realtime active power, energy and demand based on the converted analog signals for voltage and current.

The energy for +A, -A and the tariff T1,T2,T3 and T4 are counted in registers wich are stored in a non volatile memory. This values are diplayed on the LCD.

The measured energy is indicated on an LED with 1000 Imp/kWh used for testing the accuracy of the meter. Additionally the energy for +A is put to a S0-puls output with 500 Imp/kWh used for external registration devices.

### 12.2 Firmware Architecture

The functionality of the meter is periodically processed in the main loop of the application layer. The main loop is interrupted by interrupt service routines based on timer events and asynchron events.

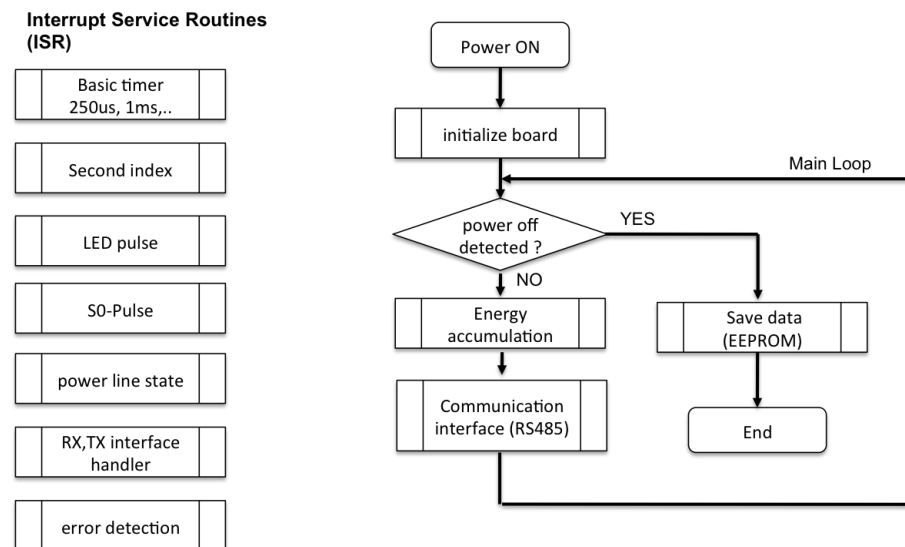



## 12.3 Energy Checksum Mechanism

The energy registers are stored once in the internal RAM of the MCU and once in the external EEPROM. In each memory two backups are available. The contents, original and backup, are stored together with a checksum.

Before the current energy consumption ( $\Delta E$ ) is accumulated to the energy registers in the RAM or EEPROM the energy registers are red out and the checksum is controlled. If the check sum is not correct the backup registers are used.

The current  $\Delta E$  is accumulated to the energy register and the check sum is calculated new. This informations are stored to the memories. Finally a new back up of the energy registers and the checksum is created.

## 12.4 Self Monitoring

The meter has an internal software watch dog. If the firmware is running abnormally without feeding the watch dog periodically, the watch dog will reset the main CPU. Watchdog events lead to fatal error if the events occur more times within a defined time slot.

The meter has implemented a self-monitoring system. If the meter recognizes no proper operation (measurement, memory check, watchdog events) so that billing relevant values may not be used anymore it displays a „Fatal Error“.

## 12.5 Additional Registration Functions

This functions are not approved according MID. The values may be used for information and not for billing purposes.

### 12.5.1 Demand channel

The demand channel the supports the following demand measurements:

- active import demand of total energy
- active import demand for T1, T2, T3 and T4
- active export demand of total energy
- active export demand for T1, T2, T3 and T4

The meter supports block methods for demand calculation:

The demand interval is programmable for 60, 120, 300, 600, 900 or 1200 seconds.

The demand can be reset by:

No.	Ways of Demand Reset	Description
1	Demand reset by software	Demand can be reset by software through RS485 interface
2	Demand reset by Button „Down“	if button is pressed more than 4 s the demand registers are stored to previous and the current register are set to zero.

There is time limit between two demand reset actions for 30minutes.

When demand reset occurs, the current energy and the maximum demand will be automatically saved for the last month. The energy of current month will be continuously cumulated, and the demand will be reset and restart to record.



### 12.5.2 History data record

There are 20 months history energy and demand data.  
All this history data can be read out via Software through RS485 interface.

### 12.5.3 Instantaneous parameter measurements

The instantaneous values can be read out via RS485 interface.

- Voltage and current
- total power factor
- total active power
- Frequency

### 12.5.4 Load profile

Load profile interval is configurable with 1, 2, 5, 10, 15, 30, 60, 120, 300, 600, 900 , 1800, 3600 seconds.

Memory capable: 8 channels(the first channel should be time) with together 43200 entries.

The load profile data are stored with time stamp.

- first channel time stamp
- up to 7 further channel with values selectable according the following list:

value	total	L1	L2	L3
Active import energy	√	---	---	---
Active export energy	√	---	---	---
Active import demand	√	---	---	---
Active export demand	√	---	---	---
Active import power	√	---	---	---
Active export power	√	---	---	---
Voltage	---	√	√	√
Current	---	√	√	√
Power factor	√	---	---	---
Frequency	√	---	---	---
Status	---	---	---	---

**Tab. 8: Load Profile Channels**

Note: √ load profile channel  
--- no load profile possible

## 12.6 Display Modes

The meter support three different display modes:

- AUTO Mode
- ALT Mode
- TEST Mode

### 12.6.1 Status Diagramm

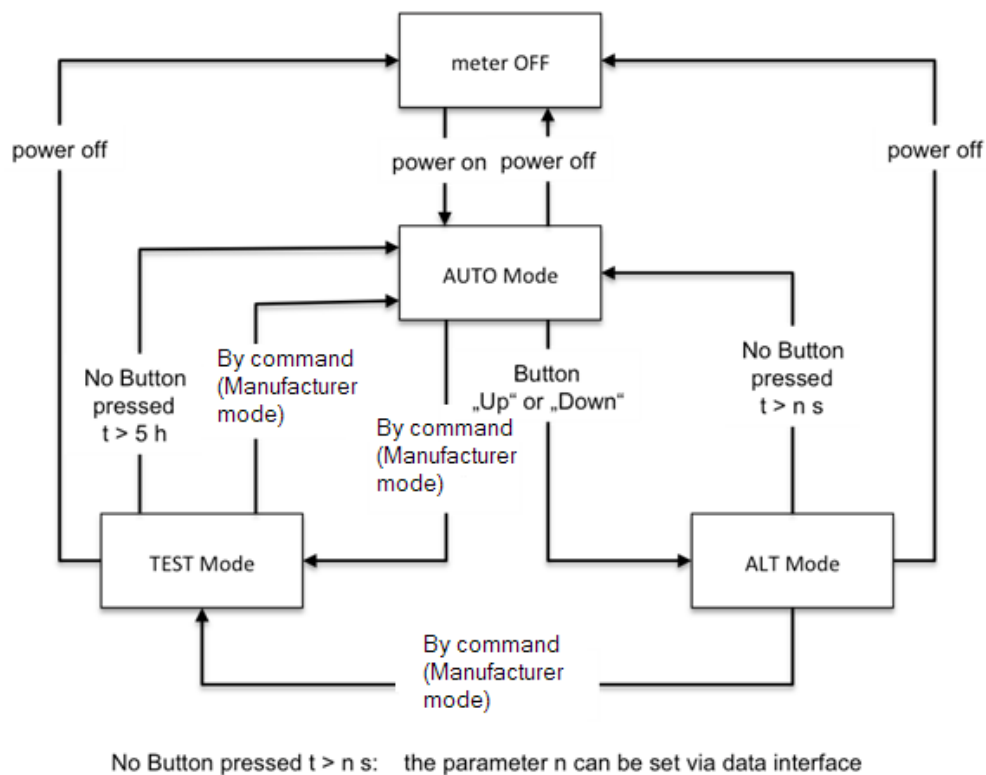

**Abb 10: Status digramm display modes**

After power on the meter shows for 2s self-check status and goes on to the AUTO-Mode. With the user buttons it can be changed between the different modes.

## 12.6.2 AUTO Mode and ALT Mode

In the AUTO Mode and ALT Mode all values which may be used for billing are displayed. This part of the display list can't be changed by the user with any interface of the meter.

The display lists can be expanded with additional values by the user via the RS485 interface and a parameter setting programm. Each list can have 32 entries.

The different values are displayed with the following formats and units:

Type of value	Format	unit
Energy	x.x	kWh
Demand	x.xxxx	kW
Power	x.x	W
Voltage	x.x	V
Current	x.xxx	A
Power Factor	x.xx	---
Date	ddmm-yy	---
Time	hh:mm:ss	---
Firmware Version	x.xx	---

**Tab. 9: Format/Unit Displayed Values**

In the AUTO Mode and ALT Mode the following display lists are fix defined:

Nr.	OBIS Code	Value	AUTO Mode	ALT Mode
1	0.2.0	Firmware Version	x	x
3	1.8.0	total active energy +A (import)	x	x
4	1.8.1	active energy +A (T1)	x	x
5	1.8.2	active energy +A (T2)	x	x
6	1.8.3	active energy +A (T3)	x	x
7	1.8.4	active energy +A (T4)	x	x
8	2.8.0	total ctive energy -A (export)	x	x
9	2.8.1	active energy -A (T1)	x	x
10	2.8.2	active energy -A (T2)	x	x
11	2.8.3	active energy -A (T3)	x	x
12	2.8.4	active energy -A (T4)	x	x
...	....	further values may be extended to the different lists setable by the user	....	....

**Tab. 10: Display Lists**

In the AUTO Mode the next value of the defined list is displayed automatically with a setable time period.

In the ALT Mode the next value is displayed after an user button was pressed.

## 12.6.3 TEST Mode

The TEST Mode list is defined by the manufacturer and can't be changed by the user. Entry or exit of the test mode can only by command in the manufacturer mode (meter cover must be open).





#### **12.6.4 Second index**

The second index is a continuously incremented second counter. It is used as time stamp for maximum demand measurement, all events inside the meter, such as time stamp for power outage, clock synchronization etc.

#### **12.6.5 Security functions**

The register for energy, demand, meter parameter and event records will be saved in non volatile memory if the power is off.

The meter detects and registers current status and events:

Event logging with date and time:

- power off (last 20 events)
- time synchronisation (last 20 events)
- time asynchron (last 20 entries)

#### **12.6.6 Fatal Error**

The meter has implemented a self-monitoring system. If the meter recognizes no proper operation so that billing relevant values may not be used anymore it displays a „Fatal Error“. This status will be indicated with current display items flashing (1Hz).

## 13 Registers

### 13.1 Instantaneous data

Access Level R: read only R/W: read/write W(M): write only in manufacturer mode (meter cover opened)				
Modbus Address	Register	Access level	Units	LCD displayed
0000	Total active import power	R	W	setable
0002	Total active export power		W	setable
0004	voltage L1	R	V	setable
0006	voltage L2	R	V	setable
0008	voltage L3	R	V	setable
000A	current L1	R	A	setable
000C	current L2	R	A	setable
000E	current L3	R	A	setable
0014	total import demand	R	W	setable
0016	total export demand	R	W	setable
0018	THD voltage L1	R	%	setable
001A	THD voltage L2	R	%	setable
001C	THD voltage L3	R	%	setable
0010	Power factor	R	A	setable
0012	Frequency	R	Hz	setable

Tab. 11: Instantaneous Data

### 13.2 Basic Parameter

Access Level R: read only R/W: read/write M: write only in manufacturer mode (meter cover opened)				
Modbus Address	Register	Access level	Units	LCD displayed
0400	Second Index	R/W(M)	s	setable
0402	Meter ID	R/W(M)		setable
0405	SoftWare Date	R/W(M)		setable
0407	SoftWare time	R/W(M)		setable
0409	Clock Asynchronous Period	R/W	s	setable
040B	Communication baud	R/W	bps	setable
040C	Rated voltage	R	V	setable
040D	Rated current	R	A	setable
040E	Frequency	R	Hz	setable
040F	Maximum current	R	A	setable
0410	Active constant	R	imp/kWh	setable
0411	Active remote constant	R/W(M)	imp/kWh	setable
0412	Demand reset number	R		setable
0413	Status Register	R/W(M)		setable

Tab. 12: Basic Parameter



### 13.2.1 Status Register

Bit	Meaning
0	RTC error
1	EEPROM Error
2	Dtaflash Error
3	reserved
4	reserved
5	reserved
6	reserved
7	reserved
8	Phase L1 failure
9	Phase L2 failure
10	Phase L3 failure
11	Phase sequence wrong
12	reserved
13	reserved
14	reserved
15	reserved

**Tab. 13: Status Register**

### 13.3 Tarif rate and Demand intervall

Access Level				
R: read only				
R/W: read/write				
M: write only in manufacturer mode (meter cover opened)				
Modbus Address	Register	Access level	Units	LCD displayed
0800	Demand interval	R/W	s	setable
0802	Current active tarif	R		no
0803	tarif rate control (fix set to exeternal)	R		no

**Tab. 14: Basic Parameter**



## 13.4 Load Profile Parameter

Access Level				
R: read only				
R/W: read/write				
M: write only in manufacturer mode (meter cover opened)				
Modbus Address	Register	Access level	Units	LCD displayed
0C00	Load profile interval	R/W	s	no
0C01	LP recorded number	R		no
0C02	Load profile channels config 1 ---Second Index	R	s	no
0C03	Load profile channels config 2	R/W		no
0C04	Load profile channels config 3	R/W		no
0C05	Load profile channels config 4	R/W		no
0C06	Load profile channels config 5	R/W		no
0C07	Load profile channels config 6	R/W		no
0C08	Load profile channels config 7	R/W		no
0C09	Load profile channels config 8	R/W		no

Tab. 15: Load Profile Parameter

## 13.5 Display Settings

Access Level				
R: read only				
R/W: read/write				
M: write only in manufacturer mode (meter cover opened)				
Modbus Address	Register	Access level	Units	LCD displayed
1000	Auto Mode Scrolling duration	R/W (M)		no
1002	In the Test Mode	R/W(M)		no
1010	Auto display item count	R/W(M)		no
1012	Test display item count	R/W(M)		no
1100	AUTO Mode Display Items 1-32	R/W		no
1120	ALT mode Display Items 1-32	R/W		no
1140	TEST Mode Display Items 1-32	R/W(M)		no

Tab. 16: Display Settings

The fix defined display lists of AUTO and ALT mode each of them individually can be extended by the user. Each display list may have 32 entries.



## 13.6 Energy Register

The meter saves up to 20 previous registers. The save function is triggered via RS485 data interface.

Access Level				
R: read only				
R/W: read/write				
M: write only in manufacturer mode (meter cover opened)				
Modbus Address	Register	Access level	Units	LCD displayed
4000	Current_Total-(Import kWh)	R	kWh	yes
4020	Current_L1-(Import kWh)	R	kWh	setable
4040	Current_L2-(Import kWh)	R	kWh	setable
4060	Current_L3-(Import kWh)	R	kWh	setable
4002	Current_Total-(Import kWh)-T1	R	kWh	yes
4004	Current_Total-(Import kWh)-T2	R	kWh	yes
4006	Current_Total-(Import kWh)-T3	R	kWh	yes
4008	Current_Total-(Import kWh)-T4	R	kWh	yes
4100	Current_Total-(Export kWh)	R	kWh	yes
4120	Current_L1-(Export kWh)	R	kWh	setable
4140	Current_L2-(Export kWh)	R	kWh	setable
4160	Current_L3-(Export kWh)	R	kWh	setable
4102	Current_Total-(Export kWh)-T1	R	kWh	yes
4104	Current_Total-(Export kWh)-T2	R	kWh	yes
4106	Current_Total-(Export kWh)-T3	R	kWh	yes
4108	Current_Total-(Export kWh)-T4	R	kWh	yes
4200	PREV1_Total-(Import kWh)	R	kWh	setable
4220	PREV1_L1-(Import kWh)	R	kWh	setable
4240	PREV1_L2-(Import kWh)	R	kWh	setable
4260	PREV1_L3-(Import kWh)	R	kWh	setable
4202	PREV1_Total-(Import kWh)-T1	R	kWh	setable
4204	PREV1_Total-(Import kWh)-T2	R	kWh	setable
4206	PREV1_Total-(Import kWh)-T3	R	kWh	setable
4208	PREV1_Total-(Import kWh)-T4	R	kWh	setable
4300	PREV1_Total-(Export kWh)	R	kWh	setable
4320	PREV1_L1-(Export kWh)	R	kWh	setable
4340	PREV1_L2-(Export kWh)	R	kWh	setable
4360	PREV1_L3-(Export kWh)	R	kWh	setable
4302	PREV1_Total-(Export kWh)-T1	R	kWh	setable
4304	PREV1_Total-(Export kWh)-T2	R	kWh	setable
4306	PREV1_Total-(Export kWh)-T3	R	kWh	setable
4308	PREV1_Total-(Export kWh)-T4	R	kWh	setable
4400	PREV2_Total-(Import kWh)	R	kWh	setable
4420	PREV2_L1-(Import kWh)	R	kWh	setable
4440	PREV2_L2-(Import kWh)	R	kWh	setable
4460	PREV2_L3-(Import kWh)	R	kWh	setable
4402	PREV2_Total-(Import kWh)-T1	R	kWh	setable
4404	PREV2_Total-(Import kWh)-T2	R	kWh	setable
4406	PREV2_Total-(Import kWh)-T3	R	kWh	setable
4408	PREV2_Total-(Import kWh)-T4	R	kWh	setable
4500	PREV2_Total-(Export kWh)	R	kWh	setable
4520	PREV2_L1-(Export kWh)	R	kWh	setable
4540	PREV2_L2-(Export kWh)	R	kWh	setable
4560	PREV2_L3-(Export kWh)	R	kWh	setable
4502	PREV2_Total-(Export kWh)-T1	R	kWh	setable
4504	PREV2_Total-(Export kWh)-T2	R	kWh	setable
4506	PREV2_Total-(Export kWh)-T3	R	kWh	setable



4508	PREV2 Total-(Export kWh)-T4	R	kWh	setable
4600	PREV3 Total-(Import kWh)	R	kWh	setable
4620	PREV3 L1-(Import kWh)	R	kWh	setable
4640	PREV3 L2-(Import kWh)	R	kWh	setable
4660	PREV3 L3-(Import kWh)	R	kWh	setable
4602	PREV3 Total-(Import kWh)-T1	R	kWh	setable
4604	PREV3 Total-(Import kWh)-T2	R	kWh	setable
4606	PREV3 Total-(Import kWh)-T3	R	kWh	setable
4608	PREV3 Total-(Import kWh)-T4	R	kWh	setable
4700	PREV3 Total-(Export kWh)	R	kWh	setable
4720	PREV3 L1-(Export kWh)	R	kWh	setable
4740	PREV3 L2-(Export kWh)	R	kWh	setable
4760	PREV3 L3-(Export kWh)	R	kWh	setable
4702	PREV3 Total-(Export kWh)-T1	R	kWh	setable
4704	PREV3 Total-(Export kWh)-T2	R	kWh	setable
4706	PREV3 Total-(Export kWh)-T3	R	kWh	setable
4708	PREV3 Total-(Export kWh)-T4	R	kWh	setable
4800	PREV4 Total-(Import kWh)	R	kWh	setable
4820	PREV4 L1-(Import kWh)	R	kWh	setable
4840	PREV4 L2-(Import kWh)	R	kWh	setable
4860	PREV4 L3-(Import kWh)	R	kWh	setable
4802	PREV4 Total-(Import kWh)-T1	R	kWh	setable
4804	PREV4 Total-(Import kWh)-T2	R	kWh	setable
4806	PREV4 Total-(Import kWh)-T3	R	kWh	setable
4808	PREV4 Total-(Import kWh)-T4	R	kWh	setable
4900	PREV4 Total-(Export kWh)	R	kWh	setable
4920	PREV4 L1-(Export kWh)	R	kWh	setable
4940	PREV4 L2-(Export kWh)	R	kWh	setable
4960	PREV4 L3-(Export kWh)	R	kWh	setable
4902	PREV4 Total-(Export kWh)-T1	R	kWh	setable
4904	PREV4 Total-(Export kWh)-T2	R	kWh	setable
4906	PREV4 Total-(Export kWh)-T3	R	kWh	setable
4908	PREV4 Total-(Export kWh)-T4	R	kWh	setable
4A00	PREV5 Total-(Import kWh)	R	kWh	setable
4A20	PREV5 L1-(Import kWh)	R	kWh	setable
4A40	PREV5 L2-(Import kWh)	R	kWh	setable
4A60	PREV5 L3-(Import kWh)	R	kWh	setable
4A02	PREV5 Total-(Import kWh)-T1	R	kWh	setable
4A04	PREV5 Total-(Import kWh)-T2	R	kWh	setable
4A06	PREV5 Total-(Import kWh)-T3	R	kWh	setable
4A08	PREV5 Total-(Import kWh)-T4	R	kWh	setable
4B00	PREV5 Total-(Export kWh)	R	kWh	setable
4B20	PREV5 L1-(Export kWh)	R	kWh	setable
4B40	PREV5 L2-(Export kWh)	R	kWh	setable
4B60	PREV5 L3-(Export kWh)	R	kWh	setable
4B02	PREV5 Total-(Export kWh)-T1	R	kWh	setable
4B04	PREV5 Total-(Export kWh)-T2	R	kWh	setable
4B06	PREV5 Total-(Export kWh)-T3	R	kWh	setable
4B08	PREV5 Total-(Export kWh)-T4	R	kWh	setable
4C00	PREV6 Total-(Import kWh)	R	kWh	setable
4C20	PREV6 L1-(Import kWh)	R	kWh	setable
4C40	PREV6 L2-(Import kWh)	R	kWh	setable
4C60	PREV6 L3-(Import kWh)	R	kWh	setable
4C02	PREV6 Total-(Import kWh)-T1	R	kWh	setable
4C04	PREV6 Total-(Import kWh)-T2	R	kWh	setable
4C06	PREV6 Total-(Import kWh)-T3	R	kWh	setable



4C08	PREV6 Total-(Import kWh)-T4	R	kWh	setable
4D00	PREV6 Total-(Export kWh)	R	kWh	setable
4D20	PREV6 L1-(Export kWh)	R	kWh	setable
4D40	PREV6 L2-(Export kWh)	R	kWh	setable
4D60	PREV6 L3-(Export kWh)	R	kWh	setable
4D02	PREV6 Total-(Export kWh)-T1	R	kWh	setable
4D04	PREV6 Total-(Export kWh)-T2	R	kWh	setable
4D06	PREV6 Total-(Export kWh)-T3	R	kWh	setable
4D08	PREV6 Total-(Export kWh)-T4	R	kWh	setable
4E00	PREV7 Total-(Import kWh)	R	kWh	setable
4E20	PREV7 L1-(Import kWh)	R	kWh	setable
4E40	PREV7 L2-(Import kWh)	R	kWh	setable
4E60	PREV7 L3-(Import kWh)	R	kWh	setable
4E02	PREV7 Total-(Import kWh)-T1	R	kWh	setable
4E04	PREV7 Total-(Import kWh)-T2	R	kWh	setable
4E06	PREV7 Total-(Import kWh)-T3	R	kWh	setable
4E08	PREV7 Total-(Import kWh)-T4	R	kWh	setable
4F00	PREV7 Total-(Export kWh)	R	kWh	setable
4F20	PREV7 L1-(Export kWh)	R	kWh	setable
4F40	PREV7 L2-(Export kWh)	R	kWh	setable
4F60	PREV7 L3-(Export kWh)	R	kWh	setable
4F02	PREV7 Total-(Export kWh)-T1	R	kWh	setable
4F04	PREV7 Total-(Export kWh)-T2	R	kWh	setable
4F06	PREV7 Total-(Export kWh)-T3	R	kWh	setable
4F08	PREV7 Total-(Export kWh)-T4	R	kWh	setable
5000	PREV8 Total-(Import kWh)	R	kWh	setable
5020	PREV8 L1-(Import kWh)	R	kWh	setable
5040	PREV8 L2-(Import kWh)	R	kWh	setable
5060	PREV8 L3-(Import kWh)	R	kWh	setable
5002	PREV8 Total-(Import kWh)-T1	R	kWh	setable
5004	PREV8 Total-(Import kWh)-T2	R	kWh	setable
5006	PREV8 Total-(Import kWh)-T3	R	kWh	setable
5008	PREV8 Total-(Import kWh)-T4	R	kWh	setable
5100	PREV8 Total-(Export kWh)	R	kWh	setable
5120	PREV8 L1-(Export kWh)	R	kWh	setable
5140	PREV8 L2-(Export kWh)	R	kWh	setable
5160	PREV8 L3-(Export kWh)	R	kWh	setable
5102	PREV8 Total-(Export kWh)-T1	R	kWh	setable
5104	PREV8 Total-(Export kWh)-T2	R	kWh	setable
5106	PREV8 Total-(Export kWh)-T3	R	kWh	setable
5108	PREV8 Total-(Export kWh)-T4	R	kWh	setable
5200	PREV9 Total-(Import kWh)	R	kWh	setable
5220	PREV9 L1-(Import kWh)	R	kWh	setable
5240	PREV9 L2-(Import kWh)	R	kWh	setable
5260	PREV9 L3-(Import kWh)	R	kWh	setable
5202	PREV9 Total-(Import kWh)-T1	R	kWh	setable
5204	PREV9 Total-(Import kWh)-T2	R	kWh	setable
5206	PREV9 Total-(Import kWh)-T3	R	kWh	setable
5208	PREV9 Total-(Import kWh)-T4	R	kWh	setable
5300	PREV9 Total-(Export kWh)	R	kWh	setable
5320	PREV9 L1-(Export kWh)	R	kWh	setable
5340	PREV9 L2-(Export kWh)	R	kWh	setable
5360	PREV9 L3-(Export kWh)	R	kWh	setable
5302	PREV9 Total-(Export kWh)-T1	R	kWh	setable
5304	PREV9 Total-(Export kWh)-T2	R	kWh	setable
5306	PREV9 Total-(Export kWh)-T3	R	kWh	setable



5308	PREV9 Total-(Export kWh)-T4	R	kWh	setable
5400	PREV10 Total-(Import kWh)	R	kWh	setable
5420	PREV10 L1-(Import kWh)	R	kWh	setable
5440	PREV10 L2-(Import kWh)	R	kWh	setable
5460	PREV10 L3-(Import kWh)	R	kWh	setable
5402	PREV10 Total-(Import kWh)-T1	R	kWh	setable
5404	PREV10 Total-(Import kWh)-T2	R	kWh	setable
5406	PREV10 Total-(Import kWh)-T3	R	kWh	setable
5408	PREV10 Total-(Import kWh)-T4	R	kWh	setable
5500	PREV10 Total-(Export kWh)	R	kWh	setable
5520	PREV10 L1-(Export kWh)	R	kWh	setable
5540	PREV10 L2-(Export kWh)	R	kWh	setable
5560	PREV10 L3-(Export kWh)	R	kWh	setable
5502	PREV10 Total-(Export kWh)-T1	R	kWh	setable
5504	PREV10 Total-(Export kWh)-T2	R	kWh	setable
5506	PREV10 Total-(Export kWh)-T3	R	kWh	setable
5508	PREV10 Total-(Export kWh)-T4	R	kWh	setable
5600	PREV11 Total-(Import kWh)	R	kWh	setable
5620	PREV11 L1-(Import kWh)	R	kWh	setable
5640	PREV11 L2-(Import kWh)	R	kWh	setable
5660	PREV11 L3-(Import kWh)	R	kWh	setable
5602	PREV11 Total-(Import kWh)-T1	R	kWh	setable
5604	PREV11 Total-(Import kWh)-T2	R	kWh	setable
5606	PREV11 Total-(Import kWh)-T3	R	kWh	setable
5608	PREV11 Total-(Import kWh)-T4	R	kWh	setable
5700	PREV11 Total-(Export kWh)	R	kWh	setable
5720	PREV11 L1-(Export kWh)	R	kWh	setable
5740	PREV11 L2-(Export kWh)	R	kWh	setable
5760	PREV11 L3-(Export kWh)	R	kWh	setable
5702	PREV11 Total-(Export kWh)-T1	R	kWh	setable
5704	PREV11 Total-(Export kWh)-T2	R	kWh	setable
5706	PREV11 Total-(Export kWh)-T3	R	kWh	setable
5708	PREV11 Total-(Export kWh)-T4	R	kWh	setable
5800	PREV12 Total-(Import kWh)	R	kWh	setable
5820	PREV12 L1-(Import kWh)	R	kWh	setable
5840	PREV12 L2-(Import kWh)	R	kWh	setable
5860	PREV12 L3-(Import kWh)	R	kWh	setable
5802	PREV12 Total-(Import kWh)-T1	R	kWh	setable
5804	PREV12 Total-(Import kWh)-T2	R	kWh	setable
5806	PREV12 Total-(Import kWh)-T3	R	kWh	setable
5808	PREV12 Total-(Import kWh)-T4	R	kWh	setable
5900	PREV12 Total-(Export kWh)	R	kWh	setable
5920	PREV12 L1-(Export kWh)	R	kWh	setable
5940	PREV12 L2-(Export kWh)	R	kWh	setable
5960	PREV12 L3-(Export kWh)	R	kWh	setable
5902	PREV12 Total-(Export kWh)-T1	R	kWh	setable
5904	PREV12 Total-(Export kWh)-T2	R	kWh	setable
5906	PREV12 Total-(Export kWh)-T3	R	kWh	setable
5908	PREV12 Total-(Export kWh)-T4	R	kWh	setable
5A00	PREV13 Total-(Import kWh)	R	kWh	setable
5A20	PREV13 L1-(Import kWh)	R	kWh	setable
5A40	PREV13 L2-(Import kWh)	R	kWh	setable
5A60	PREV13 L3-(Import kWh)	R	kWh	setable
5A02	PREV13 Total-(Import kWh)-T1	R	kWh	setable
5A04	PREV13 Total-(Import kWh)-T2	R	kWh	setable
5A06	PREV13 Total-(Import kWh)-T3	R	kWh	setable





5A08	PREV13 Total-(Import kWh)-T4	R	kWh	setable
5B00	PREV13 Total-(Export kWh)	R	kWh	setable
5B20	PREV13 L1-(Export kWh)	R	kWh	setable
5B40	PREV13 L2-(Export kWh)	R	kWh	setable
5B60	PREV13 L3-(Export kWh)	R	kWh	setable
5B02	PREV13 Total-(Export kWh)-T1	R	kWh	setable
5B04	PREV13 Total-(Export kWh)-T2	R	kWh	setable
5B06	PREV13 Total-(Export kWh)-T3	R	kWh	setable
5B08	PREV13 Total-(Export kWh)-T4	R	kWh	setable
5C00	PREV14 Total-(Import kWh)	R	kWh	setable
5C20	PREV14 L1-(Import kWh)	R	kWh	setable
5C40	PREV14 L2-(Import kWh)	R	kWh	setable
5C60	PREV14 L3-(Import kWh)	R	kWh	setable
5C02	PREV14 Total-(Import kWh)-T1	R	kWh	setable
5C04	PREV14 Total-(Import kWh)-T2	R	kWh	setable
5C06	PREV14 Total-(Import kWh)-T3	R	kWh	setable
5C08	PREV14 Total-(Import kWh)-T4	R	kWh	setable
5D00	PREV14 Total-(Export kWh)	R	kWh	setable
5D20	PREV14 L1-(Export kWh)	R	kWh	setable
5D40	PREV14 L2-(Export kWh)	R	kWh	setable
5D60	PREV14 L3-(Export kWh)	R	kWh	setable
5D02	PREV14 Total-(Export kWh)-T1	R	kWh	setable
5D04	PREV14 Total-(Export kWh)-T2	R	kWh	setable
5D06	PREV14 Total-(Export kWh)-T3	R	kWh	setable
5D08	PREV14 Total-(Export kWh)-T4	R	kWh	setable
5E00	PREV15 Total-(Import kWh)	R	kWh	setable
5E20	PREV15 L1-(Import kWh)	R	kWh	setable
5E40	PREV15 L2-(Import kWh)	R	kWh	setable
5E60	PREV15 L3-(Import kWh)	R	kWh	setable
5E02	PREV15 Total-(Import kWh)-T1	R	kWh	setable
5E04	PREV15 Total-(Import kWh)-T2	R	kWh	setable
5E06	PREV15 Total-(Import kWh)-T3	R	kWh	setable
5E08	PREV15 Total-(Import kWh)-T4	R	kWh	setable
5F00	PREV15 Total-(Export kWh)	R	kWh	setable
5F20	PREV15 L1-(Export kWh)	R	kWh	setable
5F40	PREV15 L2-(Export kWh)	R	kWh	setable
5F60	PREV15 L3-(Export kWh)	R	kWh	setable
5F02	PREV15 Total-(Export kWh)-T1	R	kWh	setable
5F04	PREV15 Total-(Export kWh)-T2	R	kWh	setable
5F06	PREV15 Total-(Export kWh)-T3	R	kWh	setable
5F08	PREV15 Total-(Export kWh)-T4	R	kWh	setable
6000	PREV16 Total-(Import kWh)	R	kWh	setable
6020	PREV16 L1-(Import kWh)	R	kWh	setable
6040	PREV16 L2-(Import kWh)	R	kWh	setable
6060	PREV16 L3-(Import kWh)	R	kWh	setable
6002	PREV16 Total-(Import kWh)-T1	R	kWh	setable
6004	PREV16 Total-(Import kWh)-T2	R	kWh	setable
6006	PREV16 Total-(Import kWh)-T3	R	kWh	setable
6008	PREV16 Total-(Import kWh)-T4	R	kWh	setable
6100	PREV16 Total-(Export kWh)	R	kWh	setable
6120	PREV16 L1-(Export kWh)	R	kWh	setable
6140	PREV16 L2-(Export kWh)	R	kWh	setable
6160	PREV16 L3-(Export kWh)	R	kWh	setable
6102	PREV16 Total-(Export kWh)-T1	R	kWh	setable
6104	PREV16 Total-(Export kWh)-T2	R	kWh	setable
6106	PREV16 Total-(Export kWh)-T3	R	kWh	setable



6108	PREV16_Total-(Export kWh)-T4	R	kWh	setable
6200	PREV17_Total-(Import kWh)	R	kWh	setable
6220	PREV17_L1-(Import kWh)	R	kWh	setable
6240	PREV17_L2-(Import kWh)	R	kWh	setable
6260	PREV17_L3-(Import kWh)	R	kWh	setable
6202	PREV17_Total-(Import kWh)-T1	R	kWh	setable
6204	PREV17_Total-(Import kWh)-T2	R	kWh	setable
6206	PREV17_Total-(Import kWh)-T3	R	kWh	setable
6208	PREV17_Total-(Import kWh)-T4	R	kWh	setable
6300	PREV17_Total-(Export kWh)	R	kWh	setable
6320	PREV17_L1-(Export kWh)	R	kWh	setable
6340	PREV17_L2-(Export kWh)	R	kWh	setable
6360	PREV17_L3-(Export kWh)	R	kWh	setable
6302	PREV17_Total-(Export kWh)-T1	R	kWh	setable
6304	PREV17_Total-(Export kWh)-T2	R	kWh	setable
6306	PREV17_Total-(Export kWh)-T3	R	kWh	setable
6308	PREV17_Total-(Export kWh)-T4	R	kWh	setable
6400	PREV18_Total-(Import kWh)	R	kWh	setable
6420	PREV18_L1-(Import kWh)	R	kWh	setable
6440	PREV18_L2-(Import kWh)	R	kWh	setable
6460	PREV18_L3-(Import kWh)	R	kWh	setable
6402	PREV18_Total-(Import kWh)-T1	R	kWh	setable
6404	PREV18_Total-(Import kWh)-T2	R	kWh	setable
6406	PREV18_Total-(Import kWh)-T3	R	kWh	setable
6408	PREV18_Total-(Import kWh)-T4	R	kWh	setable
6500	PREV18_Total-(Export kWh)	R	kWh	setable
6520	PREV18_L1-(Export kWh)	R	kWh	setable
6540	PREV18_L2-(Export kWh)	R	kWh	setable
6560	PREV18_L3-(Export kWh)	R	kWh	setable
6502	PREV18_Total-(Export kWh)-T1	R	kWh	setable
6504	PREV18_Total-(Export kWh)-T2	R	kWh	setable
6506	PREV18_Total-(Export kWh)-T3	R	kWh	setable
6508	PREV18_Total-(Export kWh)-T4	R	kWh	setable
6600	PREV19_Total-(Import kWh)	R	kWh	setable
6620	PREV19_L1-(Import kWh)	R	kWh	setable
6640	PREV19_L2-(Import kWh)	R	kWh	setable
6660	PREV19_L3-(Import kWh)	R	kWh	setable
6602	PREV19_Total-(Import kWh)-T1	R	kWh	setable
6604	PREV19_Total-(Import kWh)-T2	R	kWh	setable
6606	PREV19_Total-(Import kWh)-T3	R	kWh	setable
6608	PREV19_Total-(Import kWh)-T4	R	kWh	setable
6700	PREV19_Total-(Export kWh)	R	kWh	setable
6720	PREV19_L1-(Export kWh)	R	kWh	setable
6740	PREV19_L2-(Export kWh)	R	kWh	setable
6760	PREV19_L3-(Export kWh)	R	kWh	setable
6702	PREV19_Total-(Export kWh)-T1	R	kWh	setable
6704	PREV19_Total-(Export kWh)-T2	R	kWh	setable
6706	PREV19_Total-(Export kWh)-T3	R	kWh	setable
6708	PREV19_Total-(Export kWh)-T4	R	kWh	setable
6800	PREV20_Total-(Import kWh)	R	kWh	setable
6820	PREV20_L1-(Import kWh)	R	kWh	setable
6840	PREV20_L2-(Import kWh)	R	kWh	setable
6860	PREV20_L3-(Import kWh)	R	kWh	setable
6802	PREV20_Total-(Import kWh)-T1	R	kWh	setable
6804	PREV20_Total-(Import kWh)-T2	R	kWh	setable
6806	PREV20_Total-(Import kWh)-T3	R	kWh	setable



6808	PREV20_Total-(Import kWh)-T4	R	kWh	setable
6900	PREV20_Total-(Export kWh)	R	kWh	setable
6920	PREV20_L1-(Export kWh)	R	kWh	setable
6940	PREV20_L2-(Export kWh)	R	kWh	setable
6960	PREV20_L3-(Export kWh)	R	kWh	setable
6902	PREV20_Total-(Export kWh)-T1	R	kWh	setable
6904	PREV20_Total-(Export kWh)-T2	R	kWh	setable
6906	PREV20_Total-(Export kWh)-T3	R	kWh	setable
6908	PREV20_Total-(Export kWh)-T4	R	kWh	setable

Tab. 17: Energy Registers

## 13.7 Maximum Demand Register

The meter saves up to 20 Maximum Demand register. The demand interval is defined in register 0800. It's possible to define demand registers displayed on the LCD.

Access Level				
R: read only				
R/W: read/write				
W(M): write only in manufacturer mode (meter cover opened)				
Modbus Address	Register	Access level	Units	
8000	Current_Maximum demand-(Import kW)	R	kW	
C000	Current_Maximum demand-(Import kW) Second Index	R	s	
8002	Current_Maximum demand-(Import kW)-T1	R	kW	
C002	Current_Maximum demand-(Import kW)-T1 Second Index	R	s	
8004	Current_Maximum demand-(Import kW)-T2	R	kW	
C004	Current_Maximum demand-(Import kW)-T2 Second Index	R	s	
8006	Current_Maximum demand-(Import kW)-T3	R	kW	
C006	Current_Maximum demand-(Import kW)-T3 Second Index	R	s	
8008	Current_Maximum demand-(Import kW)-T4	R	kW	
C008	Current_Maximum demand-(Import kW)-T4 Second Index	R	s	
8100	Current_Maximum demand-(Export kW)	R	kW	
C100	Current_Maximum demand-(Export kW) Second Index	R	s	
8102	Current_Maximum demand-(Export kW)-T1	R	kW	
C102	Current_Maximum demand-(Export kW)-T1 Second Index	R	s	
8104	Current_Maximum demand-(Export kW)-T2	R	kW	
C104	Current_Maximum demand-(Export kW)-T2 Second Index	R	s	
8106	Current_Maximum demand-(Export kW)-T3	R	kW	
C106	Current_Maximum demand-(Export kW)-T3 Second Index	R	s	
8108	Current_Maximum demand-(Export kW)-T4	R	kW	
C108	Current_Maximum demand-(Export kW)-T4 Second Index	R	s	
8200	PREV1_Maximum demand-(Import kW)	R	kW	
C200	PREV1_Maximum demand-(Import kW) Second Index	R	s	
8202	PREV1_Maximum demand-(Import kW)-T1	R	kW	
C202	PREV1_Maximum demand-(Import kW)-T1 Second Index	R	s	
8204	PREV1_Maximum demand-(Import kW)-T2	R	kW	
C204	PREV1_Maximum demand-(Import kW)-T2 Second Index	R	s	
8206	PREV1_Maximum demand-(Import kW)-T3	R	kW	
C206	PREV1_Maximum demand-(Import kW)-T3 Second Index	R	s	
8208	PREV1_Maximum demand-(Import kW)-T4	R	kW	
C208	PREV1_Maximum demand-(Import kW)-T4 Second Index	R	s	
8300	PREV1_Maximum demand-(Export kW)	R	kW	
C300	PREV1_Maximum demand-(Export kW) Second Index	R	s	
8302	PREV1_Maximum demand-(Export kW)-T1	R	kW	
C302	PREV1_Maximum demand-(Export kW)-T1 Second Index	R	s	



8304	PREV1 Maximum demand-(Export kW)-T2	R	kW	
C304	PREV1 Maximum demand-(Export kW)-T2 Second Index	R	s	
8306	PREV1 Maximum demand-(Export kW)-T3	R	kW	
C306	PREV1 Maximum demand-(Export kW)-T3 Second Index	R	s	
8308	PREV1 Maximum demand-(Export kW)-T4	R	kW	
C308	PREV1 Maximum demand-(Export kW)-T4 Second Index	R	s	
8400	PREV2 Maximum demand-(Import kW)	R	kW	
C400	PREV2 Maximum demand-(Import kW) Second Index	R	s	
8402	PREV2 Maximum demand-(Import kW)-T1	R	kW	
C402	PREV2 Maximum demand-(Import kW)-T1 Second Index	R	s	
8404	PREV2 Maximum demand-(Import kW)-T2	R	kW	
C404	PREV2 Maximum demand-(Import kW)-T2 Second Index	R	s	
8406	PREV2 Maximum demand-(Import kW)-T3	R	kW	
C406	PREV2 Maximum demand-(Import kW)-T3 Second Index	R	s	
8408	PREV2 Maximum demand-(Import kW)-T4	R	kW	
C408	PREV2 Maximum demand-(Import kW)-T4 Second Index	R	s	
8500	PREV2 Maximum demand-(Export kW)	R	kW	
C500	PREV2 Maximum demand-(Export kW) Second Index	R	s	
8502	PREV2 Maximum demand-(Export kW)-T1	R	kW	
C502	PREV2 Maximum demand-(Export kW)-T1 Second Index	R	s	
8504	PREV2 Maximum demand-(Export kW)-T2	R	kW	
C504	PREV2 Maximum demand-(Export kW)-T2 Second Index	R	s	
8506	PREV2 Maximum demand-(Export kW)-T3	R	kW	
C506	PREV2 Maximum demand-(Export kW)-T3 Second Index	R	s	
8508	PREV2 Maximum demand-(Export kW)-T4	R	kW	
C508	PREV2 Maximum demand-(Export kW)-T4 Second Index	R	s	
8600	PREV3 Maximum demand-(Import kW)	R	kW	
C600	PREV3 Maximum demand-(Import kW) Second Index	R	s	
8602	PREV3 Maximum demand-(Import kW)-T1	R	kW	
C602	PREV3 Maximum demand-(Import kW)-T1 Second Index	R	s	
8604	PREV3 Maximum demand-(Import kW)-T2	R	kW	
C604	PREV3 Maximum demand-(Import kW)-T2 Second Index	R	s	
8606	PREV3 Maximum demand-(Import kW)-T3	R	kW	
C606	PREV3 Maximum demand-(Import kW)-T3 Second Index	R	s	
8608	PREV3 Maximum demand-(Import kW)-T4	R	kW	
C608	PREV3 Maximum demand-(Import kW)-T4 Second Index	R	s	
8700	PREV3 Maximum demand-(Export kW)	R	kW	
C700	PREV3 Maximum demand-(Export kW) Second Index	R	s	
8702	PREV3 Maximum demand-(Export kW)-T1	R	kW	
C702	PREV3 Maximum demand-(Export kW)-T1 Second Index	R	s	
8704	PREV3 Maximum demand-(Export kW)-T2	R	kW	
C704	PREV3 Maximum demand-(Export kW)-T2 Second Index	R	s	
8706	PREV3 Maximum demand-(Export kW)-T3	R	kW	
C706	PREV3 Maximum demand-(Export kW)-T3 Second Index	R	s	
8708	PREV3 Maximum demand-(Export kW)-T4	R	kW	
C708	PREV3 Maximum demand-(Export kW)-T4 Second Index	R	s	
8800	PREV4 Maximum demand-(Import kW)	R	kW	
C800	PREV4 Maximum demand-(Import kW) Second Index	R	s	
8802	PREV4 Maximum demand-(Import kW)-T1	R	kW	
C802	PREV4 Maximum demand-(Import kW)-T1 Second Index	R	s	
8804	PREV4 Maximum demand-(Import kW)-T2	R	kW	
C804	PREV4 Maximum demand-(Import kW)-T2 Second Index	R	s	
8806	PREV4 Maximum demand-(Import kW)-T3	R	kW	
C806	PREV4 Maximum demand-(Import kW)-T3 Second Index	R	s	
8808	PREV4 Maximum demand-(Import kW)-T4	R	kW	
C808	PREV4 Maximum demand-(Import kW)-T4 Second Index	R	s	



8900	PREV4 Maximum demand-(Export kW)	R	kW	
C900	PREV4 Maximum demand-(Export kW) Second Index	R	s	
8902	PREV4 Maximum demand-(Export kW)-T1	R	kW	
C902	PREV4 Maximum demand-(Export kW)-T1 Second Index	R	s	
8904	PREV4 Maximum demand-(Export kW)-T2	R	kW	
C904	PREV4 Maximum demand-(Export kW)-T2 Second Index	R	s	
8906	PREV4 Maximum demand-(Export kW)-T3	R	kW	
C906	PREV4 Maximum demand-(Export kW)-T3 Second Index	R	s	
8908	PREV4 Maximum demand-(Export kW)-T4	R	kW	
C908	PREV4 Maximum demand-(Export kW)-T4 Second Index	R	s	
8A00	PREV5 Maximum demand-(Import kW)	R	kW	
CA00	PREV5 Maximum demand-(Import kW) Second Index	R	s	
8A02	PREV5 Maximum demand-(Import kW)-T1	R	kW	
CA02	PREV5 Maximum demand-(Import kW)-T1 Second Index	R	s	
8A04	PREV5 Maximum demand-(Import kW)-T2	R	kW	
CA04	PREV5 Maximum demand-(Import kW)-T2 Second Index	R	s	
8A06	PREV5 Maximum demand-(Import kW)-T3	R	kW	
CA06	PREV5 Maximum demand-(Import kW)-T3 Second Index	R	s	
8A08	PREV5 Maximum demand-(Import kW)-T4	R	kW	
CA08	PREV5 Maximum demand-(Import kW)-T4 Second Index	R	s	
8B00	PREV5 Maximum demand-(Export kW)	R	kW	
CB00	PREV5 Maximum demand-(Export kW) Second Index	R	s	
8B02	PREV5 Maximum demand-(Export kW)-T1	R	kW	
CB02	PREV5 Maximum demand-(Export kW)-T1 Second Index	R	s	
8B04	PREV5 Maximum demand-(Export kW)-T2	R	kW	
CB04	PREV5 Maximum demand-(Export kW)-T2 Second Index	R	s	
8B06	PREV5 Maximum demand-(Export kW)-T3	R	kW	
CB06	PREV5 Maximum demand-(Export kW)-T3 Second Index	R	s	
8B08	PREV5 Maximum demand-(Export kW)-T4	R	kW	
CB08	PREV5 Maximum demand-(Export kW)-T4 Second Index	R	s	
8C00	PREV6 Maximum demand-(Import kW)	R	kW	
CC00	PREV6 Maximum demand-(Import kW) Second Index	R	s	
8C02	PREV6 Maximum demand-(Import kW)-T1	R	kW	
CC02	PREV6 Maximum demand-(Import kW)-T1 Second Index	R	s	
8C04	PREV6 Maximum demand-(Import kW)-T2	R	kW	
CC04	PREV6 Maximum demand-(Import kW)-T2 Second Index	R	s	
8C06	PREV6 Maximum demand-(Import kW)-T3	R	kW	
CC06	PREV6 Maximum demand-(Import kW)-T3 Second Index	R	s	
8C08	PREV6 Maximum demand-(Import kW)-T4	R	kW	
CC08	PREV6 Maximum demand-(Import kW)-T4 Second Index	R	s	
8D00	PREV6 Maximum demand-(Export kW)	R	kW	
CD00	PREV6 Maximum demand-(Export kW) Second Index	R	s	
8D02	PREV6 Maximum demand-(Export kW)-T1	R	kW	
CD02	PREV6 Maximum demand-(Export kW)-T1 Second Index	R	s	
8D04	PREV6 Maximum demand-(Export kW)-T2	R	kW	
CD04	PREV6 Maximum demand-(Export kW)-T2 Second Index	R	s	
8D06	PREV6 Maximum demand-(Export kW)-T3	R	kW	
CD06	PREV6 Maximum demand-(Export kW)-T3 Second Index	R	s	
8D08	PREV6 Maximum demand-(Export kW)-T4	R	kW	
CD08	PREV6 Maximum demand-(Export kW)-T4 Second Index	R	s	
8E00	PREV7 Maximum demand-(Import kW)	R	kW	
CE00	PREV7 Maximum demand-(Import kW) Second Index	R	s	
8E02	PREV7 Maximum demand-(Import kW)-T1	R	kW	
CE02	PREV7 Maximum demand-(Import kW)-T1 Second Index	R	s	
8E04	PREV7 Maximum demand-(Import kW)-T2	R	kW	
CE04	PREV7 Maximum demand-(Import kW)-T2 Second Index	R	s	



8E06	PREV7 Maximum demand-(Import kW)-T3	R	kW	
CE06	PREV7 Maximum demand-(Import kW)-T3 Second Index	R	s	
8E08	PREV7 Maximum demand-(Import kW)-T4	R	kW	
CE08	PREV7 Maximum demand-(Import kW)-T4 Second Index	R	s	
8F00	PREV7 Maximum demand-(Export kW)	R	kW	
CF00	PREV7 Maximum demand-(Export kW) Second Index	R	s	
8F02	PREV7 Maximum demand-(Export kW)-T1	R	kW	
CF02	PREV7 Maximum demand-(Export kW)-T1 Second Index	R	s	
8F04	PREV7 Maximum demand-(Export kW)-T2	R	kW	
CF04	PREV7 Maximum demand-(Export kW)-T2 Second Index	R	s	
8F06	PREV7 Maximum demand-(Export kW)-T3	R	kW	
CF06	PREV7 Maximum demand-(Export kW)-T3 Second Index	R	s	
8F08	PREV7 Maximum demand-(Export kW)-T4	R	kW	
CF08	PREV7 Maximum demand-(Export kW)-T4 Second Index	R	s	
9000	PREV8 Maximum demand-(Import kW)	R	kW	
D000	PREV8 Maximum demand-(Import kW) Second Index	R	s	
9002	PREV8 Maximum demand-(Import kW)-T1	R	kW	
D002	PREV8 Maximum demand-(Import kW)-T1 Second Index	R	s	
9004	PREV8 Maximum demand-(Import kW)-T2	R	kW	
D004	PREV8 Maximum demand-(Import kW)-T2 Second Index	R	s	
9006	PREV8 Maximum demand-(Import kW)-T3	R	kW	
D006	PREV8 Maximum demand-(Import kW)-T3 Second Index	R	s	
9008	PREV8 Maximum demand-(Import kW)-T4	R	kW	
D008	PREV8 Maximum demand-(Import kW)-T4 Second Index	R	s	
9100	PREV8 Maximum demand-(Export kW)	R	kW	
D100	PREV8 Maximum demand-(Export kW) Second Index	R	s	
9102	PREV8 Maximum demand-(Export kW)-T1	R	kW	
D102	PREV8 Maximum demand-(Export kW)-T1 Second Index	R	s	
9104	PREV8 Maximum demand-(Export kW)-T2	R	kW	
D104	PREV8 Maximum demand-(Export kW)-T2 Second Index	R	s	
9106	PREV8 Maximum demand-(Export kW)-T3	R	kW	
D106	PREV8 Maximum demand-(Export kW)-T3 Second Index	R	s	
9108	PREV8 Maximum demand-(Export kW)-T4	R	kW	
D108	PREV8 Maximum demand-(Export kW)-T4 Second Index	R	s	
9200	PREV9 Maximum demand-(Import kW)	R	kW	
D200	PREV9 Maximum demand-(Import kW) Second Index	R	s	
9202	PREV9 Maximum demand-(Import kW)-T1	R	kW	
D202	PREV9 Maximum demand-(Import kW)-T1 Second Index	R	s	
9204	PREV9 Maximum demand-(Import kW)-T2	R	kW	
D204	PREV9 Maximum demand-(Import kW)-T2 Second Index	R	s	
9206	PREV9 Maximum demand-(Import kW)-T3	R	kW	
D206	PREV9 Maximum demand-(Import kW)-T3 Second Index	R	s	
9208	PREV9 Maximum demand-(Import kW)-T4	R	kW	
D208	PREV9 Maximum demand-(Import kW)-T4 Second Index	R	s	
9300	PREV9 Maximum demand-(Export kW)	R	kW	
D300	PREV9 Maximum demand-(Export kW) Second Index	R	s	
9302	PREV9 Maximum demand-(Export kW)-T1	R	kW	
D302	PREV9 Maximum demand-(Export kW)-T1 Second Index	R	s	
9304	PREV9 Maximum demand-(Export kW)-T2	R	kW	
D304	PREV9 Maximum demand-(Export kW)-T2 Second Index	R	s	
9306	PREV9 Maximum demand-(Export kW)-T3	R	kW	
D306	PREV9 Maximum demand-(Export kW)-T3 Second Index	R	s	
9308	PREV9 Maximum demand-(Export kW)-T4	R	kW	
D308	PREV9 Maximum demand-(Export kW)-T4 Second Index	R	s	
9400	PREV10 Maximum demand-(Import kW)	R	kW	
D400	PREV10 Maximum demand-(Import kW) Second Index	R	s	



9402	PREV10 Maximum demand-(Import kW)-T1	R	kW	
D402	PREV10 Maximum demand-(Import kW)-T1 Second Index	R	s	
9404	PREV10 Maximum demand-(Import kW)-T2	R	kW	
D404	PREV10 Maximum demand-(Import kW)-T2 Second Index	R	s	
9406	PREV10 Maximum demand-(Import kW)-T3	R	kW	
D406	PREV10 Maximum demand-(Import kW)-T3 Second Index	R	s	
9408	PREV10 Maximum demand-(Import kW)-T4	R	kW	
D408	PREV10 Maximum demand-(Import kW)-T4 Second Index	R	s	
9500	PREV10 Maximum demand-(Export kW)	R	kW	
D500	PREV10 Maximum demand-(Export kW) Second Index	R	s	
9502	PREV10 Maximum demand-(Export kW)-T1	R	kW	
D502	PREV10 Maximum demand-(Export kW)-T1 Second Index	R	s	
9504	PREV10 Maximum demand-(Export kW)-T2	R	kW	
D504	PREV10 Maximum demand-(Export kW)-T2 Second Index	R	s	
9506	PREV10 Maximum demand-(Export kW)-T3	R	kW	
D506	PREV10 Maximum demand-(Export kW)-T3 Second Index	R	s	
9508	PREV10 Maximum demand-(Export kW)-T4	R	kW	
D508	PREV10 Maximum demand-(Export kW)-T4 Second Index	R	s	
9600	PREV11 Maximum demand-(Import kW)	R	kW	
D600	PREV11 Maximum demand-(Import kW) Second Index	R	s	
9602	PREV11 Maximum demand-(Import kW)-T1	R	kW	
D602	PREV11 Maximum demand-(Import kW)-T1 Second Index	R	s	
9604	PREV11 Maximum demand-(Import kW)-T2	R	kW	
D604	PREV11 Maximum demand-(Import kW)-T2 Second Index	R	s	
9606	PREV11 Maximum demand-(Import kW)-T3	R	kW	
D606	PREV11 Maximum demand-(Import kW)-T3 Second Index	R	s	
9608	PREV11 Maximum demand-(Import kW)-T4	R	kW	
D608	PREV11 Maximum demand-(Import kW)-T4 Second Index	R	s	
9700	PREV11 Maximum demand-(Export kW)	R	kW	
D700	PREV11 Maximum demand-(Export kW) Second Index	R	s	
9702	PREV11 Maximum demand-(Export kW)-T1	R	kW	
D702	PREV11 Maximum demand-(Export kW)-T1 Second Index	R	s	
9704	PREV11 Maximum demand-(Export kW)-T2	R	kW	
D704	PREV11 Maximum demand-(Export kW)-T2 Second Index	R	s	
9706	PREV11 Maximum demand-(Export kW)-T3	R	kW	
D706	PREV11 Maximum demand-(Export kW)-T3 Second Index	R	s	
9708	PREV11 Maximum demand-(Export kW)-T4	R	kW	
D708	PREV11 Maximum demand-(Export kW)-T4 Second Index	R	s	
970A	PREV11 Maximum demand-(Export kW)-T5	R	kW	
9800	PREV12 Maximum demand-(Import kW)	R	kW	
D800	PREV12 Maximum demand-(Import kW) Second Index	R	s	
9802	PREV12 Maximum demand-(Import kW)-T1	R	kW	
D802	PREV12 Maximum demand-(Import kW)-T1 Second Index	R	s	
9804	PREV12 Maximum demand-(Import kW)-T2	R	kW	
D804	PREV12 Maximum demand-(Import kW)-T2 Second Index	R	s	
9806	PREV12 Maximum demand-(Import kW)-T3	R	kW	
D806	PREV12 Maximum demand-(Import kW)-T3 Second Index	R	s	
9808	PREV12 Maximum demand-(Import kW)-T4	R	kW	
D808	PREV12 Maximum demand-(Import kW)-T4 Second Index	R	s	
9900	PREV12 Maximum demand-(Export kW)	R	kW	
D900	PREV12 Maximum demand-(Export kW) Second Index	R	s	
9902	PREV12 Maximum demand-(Export kW)-T1	R	kW	
D902	PREV12 Maximum demand-(Export kW)-T1 Second Index	R	s	
9904	PREV12 Maximum demand-(Export kW)-T2	R	kW	
D904	PREV12 Maximum demand-(Export kW)-T2 Second Index	R	s	
9906	PREV12 Maximum demand-(Export kW)-T3	R	kW	



D906	PREV12 Maximum demand-(Export kW)-T3 Second Index	R	s	
9908	PREV12 Maximum demand-(Export kW)-T4	R	kW	
D908	PREV12 Maximum demand-(Export kW)-T4 Second Index	R	s	
9A00	PREV13 Maximum demand-(Import kW)	R	kW	
DA00	PREV13 Maximum demand-(Import kW) Second Index	R	s	
9A02	PREV13 Maximum demand-(Import kW)-T1	R	kW	
DA02	PREV13 Maximum demand-(Import kW)-T1 Second Index	R	s	
9A04	PREV13 Maximum demand-(Import kW)-T2	R	kW	
DA04	PREV13 Maximum demand-(Import kW)-T2 Second Index	R	s	
9A06	PREV13 Maximum demand-(Import kW)-T3	R	kW	
DA06	PREV13 Maximum demand-(Import kW)-T3 Second Index	R	s	
9A08	PREV13 Maximum demand-(Import kW)-T4	R	kW	
DA08	PREV13 Maximum demand-(Import kW)-T4 Second Index	R	s	
9B00	PREV13 Maximum demand-(Export kW)	R	kW	
DB00	PREV13 Maximum demand-(Export kW) Second Index	R	s	
9B02	PREV13 Maximum demand-(Export kW)-T1	R	kW	
DB02	PREV13 Maximum demand-(Export kW)-T1 Second Index	R	s	
9B04	PREV13 Maximum demand-(Export kW)-T2	R	kW	
DB04	PREV13 Maximum demand-(Export kW)-T2 Second Index	R	s	
9B06	PREV13 Maximum demand-(Export kW)-T3	R	kW	
DB06	PREV13 Maximum demand-(Export kW)-T3 Second Index	R	s	
9B08	PREV13 Maximum demand-(Export kW)-T4	R	kW	
DB08	PREV13 Maximum demand-(Export kW)-T4 Second Index	R	s	
DB10	PREV13 Maximum demand-(Export kW)-T8 Second Index	R	s	
9C00	PREV14 Maximum demand-(Import kW)	R	kW	
DC00	PREV14 Maximum demand-(Import kW) Second Index	R	s	
9C02	PREV14 Maximum demand-(Import kW)-T1	R	kW	
DC02	PREV14 Maximum demand-(Import kW)-T1 Second Index	R	s	
9C04	PREV14 Maximum demand-(Import kW)-T2	R	kW	
DC04	PREV14 Maximum demand-(Import kW)-T2 Second Index	R	s	
9C06	PREV14 Maximum demand-(Import kW)-T3	R	kW	
DC06	PREV14 Maximum demand-(Import kW)-T3 Second Index	R	s	
9C08	PREV14 Maximum demand-(Import kW)-T4	R	kW	
DC08	PREV14 Maximum demand-(Import kW)-T4 Second Index	R	s	
9D00	PREV14 Maximum demand-(Export kW)	R	kW	
DD00	PREV14 Maximum demand-(Export kW) Second Index	R	s	
9D02	PREV14 Maximum demand-(Export kW)-T1	R	kW	
DD02	PREV14 Maximum demand-(Export kW)-T1 Second Index	R	s	
9D04	PREV14 Maximum demand-(Export kW)-T2	R	kW	
DD04	PREV14 Maximum demand-(Export kW)-T2 Second Index	R	s	
9D06	PREV14 Maximum demand-(Export kW)-T3	R	kW	
DD06	PREV14 Maximum demand-(Export kW)-T3 Second Index	R	s	
9D08	PREV14 Maximum demand-(Export kW)-T4	R	kW	
DD08	PREV14 Maximum demand-(Export kW)-T4 Second Index	R	s	
9E00	PREV15 Maximum demand-(Import kW)	R	kW	
DE00	PREV15 Maximum demand-(Import kW) Second Index	R	s	
9E02	PREV15 Maximum demand-(Import kW)-T1	R	kW	
DE02	PREV15 Maximum demand-(Import kW)-T1 Second Index	R	s	
9E04	PREV15 Maximum demand-(Import kW)-T2	R	kW	
DE04	PREV15 Maximum demand-(Import kW)-T2 Second Index	R	s	
9E06	PREV15 Maximum demand-(Import kW)-T3	R	kW	
DE06	PREV15 Maximum demand-(Import kW)-T3 Second Index	R	s	
9E08	PREV15 Maximum demand-(Import kW)-T4	R	kW	
DE08	PREV15 Maximum demand-(Import kW)-T4 Second Index	R	s	
9F00	PREV15 Maximum demand-(Export kW)	R	kW	
DF00	PREV15 Maximum demand-(Export kW) Second Index	R	s	





9F02	PREV15 Maximum demand-(Export kW)-T1	R	kW	
DF02	PREV15 Maximum demand-(Export kW)-T1 Second Index	R	s	
9F04	PREV15 Maximum demand-(Export kW)-T2	R	kW	
DF04	PREV15 Maximum demand-(Export kW)-T2 Second Index	R	s	
9F06	PREV15 Maximum demand-(Export kW)-T3	R	kW	
DF06	PREV15 Maximum demand-(Export kW)-T3 Second Index	R	s	
9F08	PREV15 Maximum demand-(Export kW)-T4	R	kW	
DF08	PREV15 Maximum demand-(Export kW)-T4 Second Index	R	s	
A000	PREV16 Maximum demand-(Import kW)	R	kW	
E000	PREV16 Maximum demand-(Import kW) Second Index	R	s	
A002	PREV16 Maximum demand-(Import kW)-T1	R	kW	
E002	PREV16 Maximum demand-(Import kW)-T1 Second Index	R	s	
A004	PREV16 Maximum demand-(Import kW)-T2	R	kW	
E004	PREV16 Maximum demand-(Import kW)-T2 Second Index	R	s	
A006	PREV16 Maximum demand-(Import kW)-T3	R	kW	
E006	PREV16 Maximum demand-(Import kW)-T3 Second Index	R	s	
A008	PREV16 Maximum demand-(Import kW)-T4	R	kW	
E008	PREV16 Maximum demand-(Import kW)-T4 Second Index	R	s	
A100	PREV16 Maximum demand-(Export kW)	R	kW	
E100	PREV16 Maximum demand-(Export kW) Second Index	R	s	
A102	PREV16 Maximum demand-(Export kW)-T1	R	kW	
E102	PREV16 Maximum demand-(Export kW)-T1 Second Index	R	s	
A104	PREV16 Maximum demand-(Export kW)-T2	R	kW	
E104	PREV16 Maximum demand-(Export kW)-T2 Second Index	R	s	
A106	PREV16 Maximum demand-(Export kW)-T3	R	kW	
E106	PREV16 Maximum demand-(Export kW)-T3 Second Index	R	s	
A108	PREV16 Maximum demand-(Export kW)-T4	R	kW	
E108	PREV16 Maximum demand-(Export kW)-T4 Second Index	R	s	
A200	PREV17 Maximum demand-(Import kW)	R	kW	
E200	PREV17 Maximum demand-(Import kW) Second Index	R	s	
A202	PREV17 Maximum demand-(Import kW)-T1	R	kW	
E202	PREV17 Maximum demand-(Import kW)-T1 Second Index	R	s	
A204	PREV17 Maximum demand-(Import kW)-T2	R	kW	
E204	PREV17 Maximum demand-(Import kW)-T2 Second Index	R	s	
A206	PREV17 Maximum demand-(Import kW)-T3	R	kW	
E206	PREV17 Maximum demand-(Import kW)-T3 Second Index	R	s	
A208	PREV17 Maximum demand-(Import kW)-T4	R	kW	
E208	PREV17 Maximum demand-(Import kW)-T4 Second Index	R	s	
A300	PREV17 Maximum demand-(Export kW)	R	kW	
E300	PREV17 Maximum demand-(Export kW) Second Index	R	s	
A302	PREV17 Maximum demand-(Export kW)-T1	R	kW	
E302	PREV17 Maximum demand-(Export kW)-T1 Second Index	R	s	
A304	PREV17 Maximum demand-(Export kW)-T2	R	kW	
E304	PREV17 Maximum demand-(Export kW)-T2 Second Index	R	s	
A306	PREV17 Maximum demand-(Export kW)-T3	R	kW	
E306	PREV17 Maximum demand-(Export kW)-T3 Second Index	R	s	
A308	PREV17 Maximum demand-(Export kW)-T4	R	kW	
E308	PREV17 Maximum demand-(Export kW)-T4 Second Index	R	s	
A400	PREV18 Maximum demand-(Import kW)	R	kW	
E400	PREV18 Maximum demand-(Import kW) Second Index	R	s	
A402	PREV18 Maximum demand-(Import kW)-T1	R	kW	
E402	PREV18 Maximum demand-(Import kW)-T1 Second Index	R	s	
A404	PREV18 Maximum demand-(Import kW)-T2	R	kW	
E404	PREV18 Maximum demand-(Import kW)-T2 Second Index	R	s	
A406	PREV18 Maximum demand-(Import kW)-T3	R	kW	
E406	PREV18 Maximum demand-(Import kW)-T3 Second Index	R	s	



A408	PREV18 Maximum demand-(Import kW)-T4	R	kW	
E408	PREV18 Maximum demand-(Import kW)-T4 Second Index	R	s	
A500	PREV18 Maximum demand-(Export kW)	R	kW	
E500	PREV18 Maximum demand-(Export kW) Second Index	R	s	
A502	PREV18 Maximum demand-(Export kW)-T1	R	kW	
E502	PREV18 Maximum demand-(Export kW)-T1 Second Index	R	s	
A504	PREV18 Maximum demand-(Export kW)-T2	R	kW	
E504	PREV18 Maximum demand-(Export kW)-T2 Second Index	R	s	
A506	PREV18 Maximum demand-(Export kW)-T3	R	kW	
E506	PREV18 Maximum demand-(Export kW)-T3 Second Index	R	s	
A508	PREV18 Maximum demand-(Export kW)-T4	R	kW	
E508	PREV18 Maximum demand-(Export kW)-T4 Second Index	R	s	
A600	PREV19 Maximum demand-(Import kW)	R	kW	
E600	PREV19 Maximum demand-(Import kW) Second Index	R	s	
A602	PREV19 Maximum demand-(Import kW)-T1	R	kW	
E602	PREV19 Maximum demand-(Import kW)-T1 Second Index	R	s	
A604	PREV19 Maximum demand-(Import kW)-T2	R	kW	
E604	PREV19 Maximum demand-(Import kW)-T2 Second Index	R	s	
A606	PREV19 Maximum demand-(Import kW)-T3	R	kW	
E606	PREV19 Maximum demand-(Import kW)-T3 Second Index	R	s	
A608	PREV19 Maximum demand-(Import kW)-T4	R	kW	
E608	PREV19 Maximum demand-(Import kW)-T4 Second Index	R	s	
A700	PREV19 Maximum demand-(Export kW)	R	kW	
E700	PREV19 Maximum demand-(Export kW) Second Index	R	s	
A702	PREV19 Maximum demand-(Export kW)-T1	R	kW	
E702	PREV19 Maximum demand-(Export kW)-T1 Second Index	R	s	
A704	PREV19 Maximum demand-(Export kW)-T2	R	kW	
E704	PREV19 Maximum demand-(Export kW)-T2 Second Index	R	s	
A706	PREV19 Maximum demand-(Export kW)-T3	R	kW	
E706	PREV19 Maximum demand-(Export kW)-T3 Second Index	R	s	
A708	PREV19 Maximum demand-(Export kW)-T4	R	kW	
E708	PREV19 Maximum demand-(Export kW)-T4 Second Index	R	s	
A800	PREV20 Maximum demand-(Import kW)	R	kW	
E800	PREV20 Maximum demand-(Import kW) Second Index	R	s	
A802	PREV20 Maximum demand-(Import kW)-T1	R	kW	
E802	PREV20 Maximum demand-(Import kW)-T1 Second Index	R	s	
A804	PREV20 Maximum demand-(Import kW)-T2	R	kW	
E804	PREV20 Maximum demand-(Import kW)-T2 Second Index	R	s	
A806	PREV20 Maximum demand-(Import kW)-T3	R	kW	
E806	PREV20 Maximum demand-(Import kW)-T3 Second Index	R	s	
A808	PREV20 Maximum demand-(Import kW)-T4	R	kW	
E808	PREV20 Maximum demand-(Import kW)-T4 Second Index	R	s	
A900	PREV20 Maximum demand-(Export kW)	R	kW	
E900	PREV20 Maximum demand-(Export kW) Second Index	R	s	
A902	PREV20 Maximum demand-(Export kW)-T1	R	kW	
E902	PREV20 Maximum demand-(Export kW)-T1 Second Index	R	s	
A904	PREV20 Maximum demand-(Export kW)-T2	R	kW	
E904	PREV20 Maximum demand-(Export kW)-T2 Second Index	R	s	
A906	PREV20 Maximum demand-(Export kW)-T3	R	kW	
E906	PREV20 Maximum demand-(Export kW)-T3 Second Index	R	s	
A908	PREV20 Maximum demand-(Export kW)-T4	R	kW	
E908	PREV20 Maximum demand-(Export kW)-T4 Second Index	R	s	

**Tab. 18: Maximum Demand Registers**



## 13.8 Logging Register

The logging register are not displayed on the LCD.

### 13.8.1 Logging Demand Resets

Access Level			
R: read only			
R/W: read/write			
W(M): write only in manufacturer mode (meter cover opened)			
Modbus Address	Register	Access level	Units
2000	Demand reset record01	R	s
2002	Demand reset record02	R	s
2004	Demand reset record03	R	s
2006	Demand reset record04	R	s
2008	Demand reset record05	R	s
200A	Demand reset record06	R	s
200C	Demand reset record07	R	s
200E	Demand reset record08	R	s
2010	Demand reset record09	R	s
2012	Demand reset record10	R	s
2014	Demand reset record11	R	s
2016	Demand reset record12	R	s
2018	Demand reset record13	R	s
201A	Demand reset record14	R	s
201C	Demand reset record15	R	s
201E	Demand reset record16	R	s
2020	Demand reset record17	R	s
2022	Demand reset record18	R	s
2024	Demand reset record19	R	s
2026	Demand reset record20	R	s

**Tab. 19: Logging Demand Registers**



### 13.8.2 Logging Power Outages

<b>Access Level</b>			
R: read only			
R/W: read/write			
W(M): write only in manufacturer mode (meter cover opened)			
<b>Modbus Address</b>	<b>Register</b>	<b>Access level</b>	
2400	Power Outages LOG01	R	
2404	Power Outages LOG02	R	
2408	Power Outages LOG03	R	
240C	Power Outages LOG04	R	
2410	Power Outages LOG05	R	
2414	Power Outages LOG06	R	
2418	Power Outages LOG07	R	
241C	Power Outages LOG08	R	
2420	Power Outages LOG09	R	
2424	Power Outages LOG10	R	
2428	Power Outages LOG11	R	
242C	Power Outages LOG12	R	
2430	Power Outages LOG13	R	
2434	Power Outages LOG14	R	
2438	Power Outages LOG15	R	
243C	Power Outages LOG16	R	
2440	Power Outages LOG17	R	
2444	Power Outages LOG18	R	
2448	Power Outages LOG19	R	
244C	Power Outages LOG20	R	

**Tab. 20: Logging Power Outages**



### 13.8.3 Logging Clock Synchronisation

<b>Access Level</b>			
R: read only			
R/W: read/write			
W(M): write only in manufacturer mode (meter cover opened)			
<b>Modbus Address</b>	<b>Register</b>	<b>Access level</b>	
2600	Clock synchronous LOG01	R	
2606	Clock synchronous LOG02	R	
260C	Clock synchronous LOG03	R	
2612	Clock synchronous LOG04	R	
2618	Clock synchronous LOG05	R	
261E	Clock synchronous LOG06	R	
2624	Clock synchronous LOG07	R	
262A	Clock synchronous LOG08	R	
2630	Clock synchronous LOG09	R	
2636	Clock synchronous LOG10	R	
263C	Clock synchronous LOG11	R	
2642	Clock synchronous LOG12	R	
2648	Clock synchronous LOG13	R	
264E	Clock synchronous LOG14	R	
2654	Clock synchronous LOG15	R	
265A	Clock synchronous LOG16	R	
2660	Clock synchronous LOG17	R	
2666	Clock synchronous LOG18	R	
266C	Clock synchronous LOG19	R	
2672	Clock synchronous LOG20	R	
2800	Clock asynchronous LOG01	R	
2802	Clock asynchronous LOG02	R	
2804	Clock asynchronous LOG03	R	
2806	Clock asynchronous LOG04	R	
2808	Clock asynchronous LOG05	R	
280A	Clock asynchronous LOG06	R	
280C	Clock asynchronous LOG07	R	
280E	Clock asynchronous LOG08	R	
2810	Clock asynchronous LOG09	R	
2812	Clock asynchronous LOG10	R	
2814	Clock asynchronous LOG11	R	
2816	Clock asynchronous LOG12	R	
2818	Clock asynchronous LOG13	R	
281A	Clock asynchronous LOG14	R	
281C	Clock asynchronous LOG15	R	
281E	Clock asynchronous LOG16	R	
2820	Clock asynchronous LOG17	R	
2822	Clock asynchronous LOG18	R	
2824	Clock asynchronous LOG19	R	
2826	Clock asynchronous LOG20	R	

**Tab. 21: Logging Clock Synchronisation**

## 13.9 Accuracy Test

The accuracy of the meter is done with the pulse LEDs. For testing the following quantity of minimum pulses dependant from the load are recommended:

Load(I)	Min. quantity pulses
$I_{st} - I_{tr}$	1
$I_{tr} - I_{ref}$	5
$> I_{ref}$	10

**Tab. 22: Quantity of pulses**

## 14 Manufacturing

The final assembling is done by DZG Oranienburg GmbH. The company is certified according to the quality standard DIN EN ISO 9001. DZG provides an certified testing center for electricity meters EN 20.

The processes, controls and documentations are organized according to the quality standard. Each meter will be tested in the certified testing center (100% unit test).



## 15 EG-Declaration of Conformit



<b>EG-Konformitätserklärung</b> <b>EC Declaration of Conformity</b>	<b>DZG Metering GmbH</b> Heidelberger Strasse 32 16515 Oranienburg Telefon +49-(0)3301 - 854 - 0 Telefax +49-(0)3301 - 854 - 173 Mittelbrandenburgische Sparkasse, Potsdam (BLZ: 160 500 00) Konto: 37 400 300 37 BIC: WELA DE D1 PMB IBAN: DE81 1605 0000 3740 0300 37

nach EMV-Richtlinie 2004/108/EG  
acc. To EMC Directive 2004/108/EC

nach Messgeräte-Richtlinie 2004/22/EG (MID)  
acc to Measuring Instruments Directice 2004/22/EC (MID)

### Hersteller/manufacturer

DZG Metering GmbH  
Heidelberger Strasse 32  
D-16515 Oranienburg

**Erklärt hiermit in eigener Verantwortung, dass folgendes Produkt**  
Certifies on its own responsibility that the following product is

Produktbezeichnung: Elektrizitätszähler  
Product Designation: Electricity meter  
Typenbezeichnung: DVH4013  
Type designation

**den Bedingungen der oben genannten Richtlinien- einschließlich deren zum Zeitpunkt der Erklärung geltenden Änderungen- entspricht.**

Conform to above mentioned directives including all amendments valid at the moment of issuing this declaration.

**Die Konformität des Baumusters (Modul B) mit den unten angeführten Normen wurde festgestellt:**

The conformity of the type (Modul B) with the listed standards was ascertained:

Benannte Stelle (Name/Nummer): CSA Group Bayern GmbH/1948  
Notified Body (name/number)  
Baumusterprüfbescheinigungs-Nr: DE MTP 14 B 002 MI-003  
Type examination certificate number

**Das Gerät erfüllt folgende harmonisierte Normen:**

The device meets the requirements of the following harmonized standards:

EMV-Richtlinie 2004/108/EG	MID 2004/22/EG
EMC Directive 2004/108/EC	MID 2004/22/EC
EN 55022-2006	EN50470-1:2006
EN 62052-11:2003	EN50470-3:2006
EN 62053-21:2003	

**Die Konformitätsbewertung wurde nach Modul D durch den Hersteller vorgenommen:**

The conformity assessment was performed by the manufacturer acc. Modul D:

Benannte Stelle (Name/Nummer): CSA Group Bayern GmbH/1948  
Notified Body (name/number)  
Zertifikats-Nummer: DE MTP 12 D 001 MI-003  
Certificate number

Ort/place, Datum/date: Oranienburg, 11.06.2014

  
Dipl.- Inform. Ulrich Feldmüller  
Geschäftsführer  
DZG Metering GmbH

  
Dipl. Ing. (FH) Peter Zintl  
Geschäftsführer  
DZG Metering GmbH

Sitz der Gesellschaft Oranienburg, Neuruppin HRB 7193 NP, Geschäftsführer: Ulrich Feldmüller, Peter Zintl

Ust.-Ident-Nr. DE 814351540