



Tapping Machine for Building Acoustic applications

Nor277 is a tapping machine for impact noise measurements designed to meet the requirements given in ISO 140 parts 6, 7 and 8 as well as ASTM E492-04 and ASTM E1007-04e1. The tapping machine has a monitoring system for verification of proper impact frequency and the speed of each falling hammer. The unit is mains operated but may optionally also be powered from internal rechargeable batteries.

The impacts may be remotely switched on/off by the serial interface or from an optional wireless remote control.



tapping **machine**



Nor277 User Guide

Im277_1Ed1R0En – Desember 2007

Norsonic is a registered trademark of Norsonic AS. All other brand or product names are trademarks or registered trademarks of their respective companies.

Every effort has been made to supply complete and accurate information. However, Norsonic AS assumes no responsibility for the use of – nor for the consequential damages of the use of – this information and/or the instrumentation described herein. Furthermore Norsonic AS assumes no responsibility for any infringement of the intellectual property rights of third parties, wherever applicable, which would result from such use.

Norsonic AS reserves the right to amend any of the information given in this manual in order to take account of new developments.

If you wish to communicate with us, please feel welcome.

Our address is:

Norsonic AS, P.O. Box 24, N-3421 Lierskogen, Norway

Find us on the web: www.norsonic.com

Tel: +47 3285 8900

Fax: +47 3285 2208

e-mail: info@norsonic.no

Copyright © Norsonic AS 2007

All rights reserved

nor277



Thank you for choosing Norsonic. The tapping machine Nor277 has been designed to provide you with many years of safe, reliable operation.

We recommend that you take your time to read through this little booklet before you start using the equipment.

For optimum use of the tapping machine we recommend that you get yourself a copy of relevant standards applicable to your tapping machine application.

Tranby, December 2007

Ni Norsonic

Caution!

The tapping machine Nor277 is IP40 protected.

For indoor use only!

The unit must be protected from rain and dust.

Moving parts!

Never move the unit while it is running.

Set the On/Off switch to Off position before making any check of hammer height or adjustments to the unit.

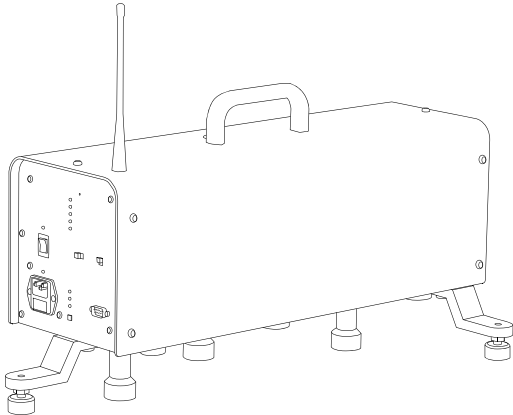

- 6 Introduction
- 7 Main parts
- 8 Front panel
- 9 Operation
- 11 Remote commands
- 12 Making measurements
- 13 Specifications
- 14 Declaration of conformity

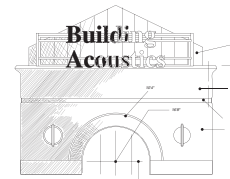
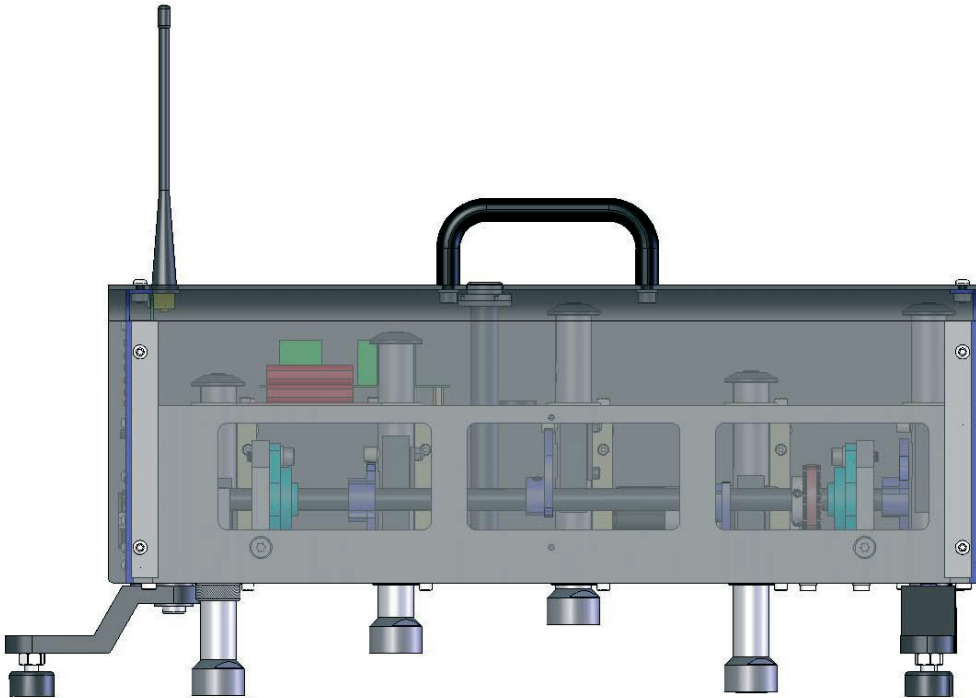

Using the Tapping Machine Nor277

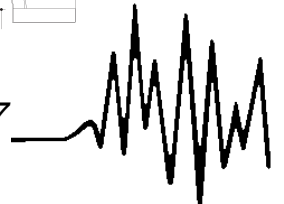



Introduction

The tapping machine Nor277 is the third generation of tapping machines from Norsonic for performing standardised impact noise tests (foot fall noise). It incorporates all the experience from the former generations into a compact, light, yet a rugged unit with the construction based on an extruded aluminium chassis. The hammers are made of hardened stainless steel, ensuring non-deformation of the hammer shape even after years in use. The unit weight is only 10 kg including the optional battery. Retractable feet ensure easy transportation and storage.

The unit has the required five hammers each weighting 500 g, with a fall height of 40 mm and 100 ms between each hammer impact. A crystal controlled servo system ensures the correct tapping frequency is maintained at all times and temperatures.

A spirit level gauge mounted on the top assists the user to obtain vertical fall direction.

Each hammer is fitted with an optical sensor to measure the impact rate and velocity for ensuring that the energy imparted into the test floor is correct. Hence the effects of any friction or misalignment are immediately apparent.

Each hammer has a LED indicator on the front panel that indicates when the impact velocity and tapping frequency are within the requirements of the standard. The user can now be assured that the excitation generated by the system conforms to the requirements of the standards and therefore concentrate on the other aspects of the measurement.



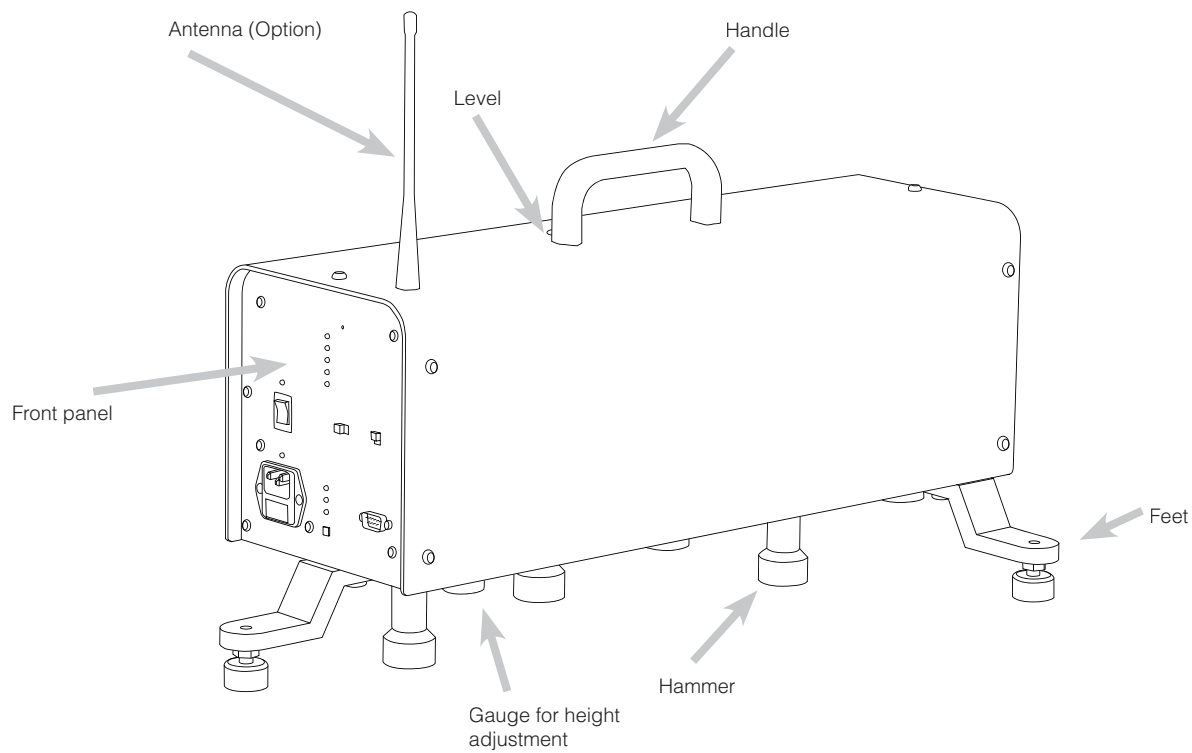

Front panel

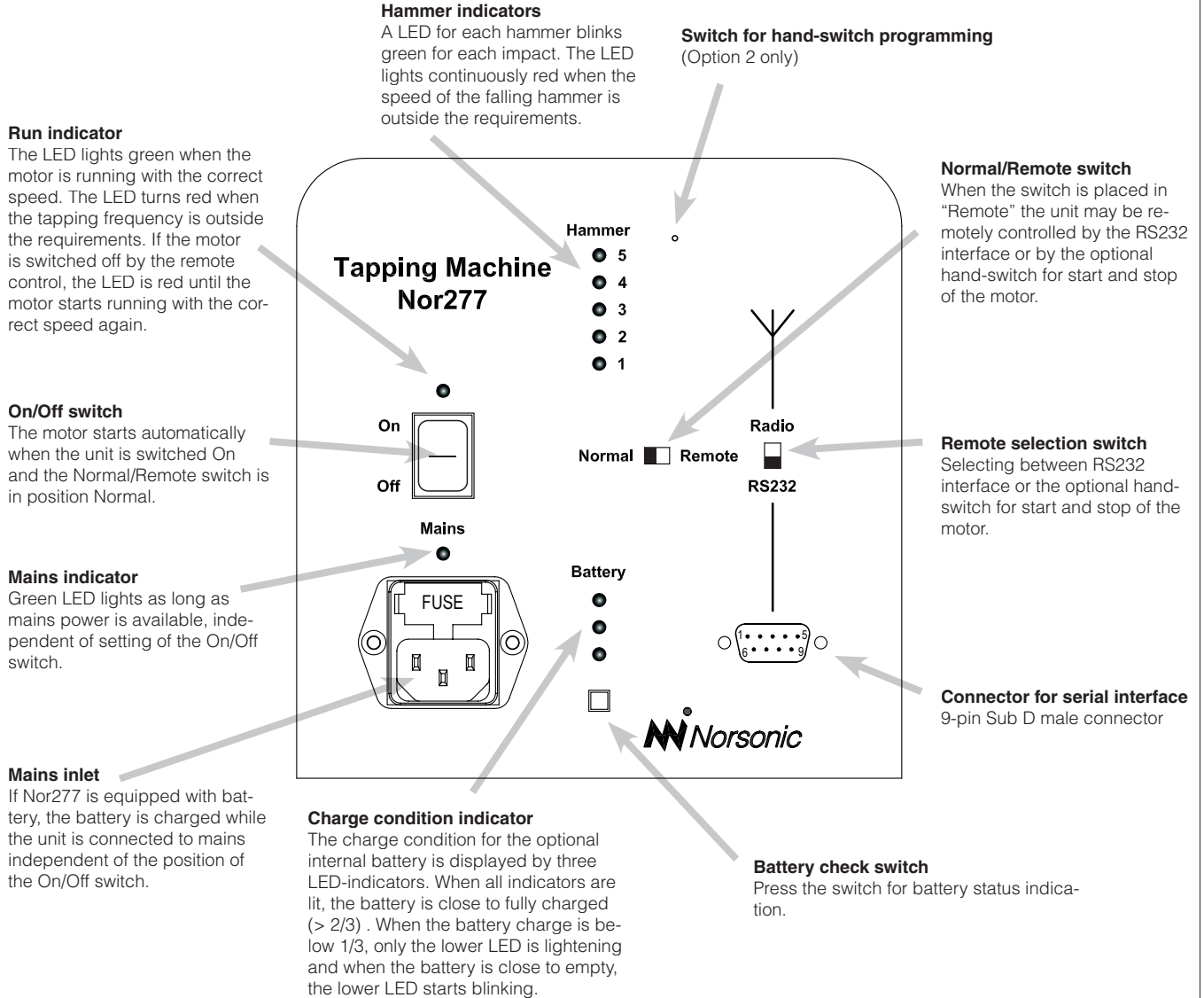

Mains or battery operation

All Nor277 tapping machines may be powered from mains. Optionally, the unit can be equipped with an internal battery (option 1) that will run the unit for more than one hour. Mains are automatically selected when available. When connected to mains the green LED (Light Emitting Diode) for mains indication is lit.

Normal operation

For normal operation, set the Normal/Remote switch to Normal. Use the On/Off switch for starting and stopping the tapping machine. Correct operation is indicated by green colour on all LEDs. Correct impact frequency is indicated by green colour on the Run indicator above the On/Off switch. The motor speed is monitored by the crystal controlled digital processor and the LED change from green to red if the speed deviation is more than 5%. The LED will indicate when the mean time between impacts is outside the tolerance limits. The time between the impacts from each hammer may be logged by the serial interface.

Correct speed of the falling hammers are indicated by a green blinking LED for each impact of the various hammers. If the speed of the falling hammers is outside the limits, the LED starts to light continuously red.

When the tapping machine is placed on some resilient floors (carpets) the movement of the machine may slow down the falling speed of the hammers as can be seen from red hammer indicators. If you experience this situation, load the machine or the feet of the machine to prevent the movement.

Operation controlled from the hand switch

This mode of operation requires option 2 to be installed. This option enables the user to control the On/Off without being present in the source room. Typical range is 100 m in free field, but will also transmit through a concrete wall/floor. US version is limited to 50 m due to FCC regulations.

Verify that the supplied antenna is mounted on the top of the machine.

Set the Normal/Remote switch to Remote and the Remote selection switch to Radio.

Switch On the tapping machine. The Run indicator will light red to indicate no motor speed. Press the button on the hand-switch to start the tapping. A second press will stop the operation (toggeling).

Note: The hand-switch and the tapping machined have to be paired. When delivered, this pairing has already been done. An alternative hand-switch or more hand-switches may be paired to the same machine – or vice versa. See: Programming the hand-switch.



The Hand-switch allows the tapping machine to be started and stopped from remote. The switch is a part of option 2.

Remote operation – Serial interface

The tapping machine Nor277 may be remotely controlled by a RS 232 serial interface, (9600 baud) with hardware handshake. Commands are ignored if the Normal/Remote switch is not set to Remote and the Remote selection switch to RS232.

If the computer or other controlling device has a 9-pin serial port with a male connector, use a null modem cable like Nor1463 for the connection.

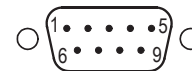

Pin no	Signal	Dir
1		
2	RD	In
3	TD	Out
4		
5	GND	
6		
7	RTS	Out
8	CTS	In
9	5 volt (50 mA)	Out
Housing	GND	

Set the On/Off switch to Off for safety reasons when the unit is not in use or when the fall height of the hammer is adjusted or other adjustments or maintenance are done.



Operation

Maintenance

When delivered, the Nor277 is verified to fulfil all requirements in the referred standards including the height of the falling hammers. Some applications may require a readjustment of the height; therefore the fall height of the hammers should be checked and adjusted, if needed.

The check should be carried out on a flat, horizontal table or a horizontal floor. A tool for this is included – a rod mounted on the underside of the machine. The length of this gauge corresponds to the distance between the bottom of the tapping machine and the floor for obtaining an effective fall height of 40 mm for the hammers. Note that the lifted hammers should be 40,5 mm above the floor in order to compensate for losses due to friction. Place the gauge at the line between the hammers close to the foot to be checked (See adjacent picture).

If adjustments are needed:

- 1 Adjust the three feet of the tapping machine until the correct height is obtained. Make sure the machine is standing level (in both directions) while doing this.
- 2 Once an acceptable fall height has been reached, lock the position of each foot using the enclosed 13 mm wrench on the nut.
- 3 Put the fall height gauge back in place.

If the monitors for the falling hammers indicate excess friction, the hammers and the guides have to be cleaned and oiled. Since the tapping machine may be used in a variety of environmental condition it is difficult to predict how often this has to be done. We recommend that this maintenance is done



by a Norsonic service department.

It is recommended that the tapping machine is calibrated by an accredited calibration laboratory at least every second year.

Battery maintenance

The optional battery is of the lithium-ion type and is automatically charged while the unit is connected to mains. We recommend keeping a tapping machine in regular use connected to the mains supply when stored. This will ensure that the battery is fully charged and ready for use. The charge control will prevent the battery from being overcharged. A three step LED battery monitor tells the user about the state of charge. Charging time for an empty battery is 2 hours. The mains switch should be set to off position when charging the batteries.

No other maintenance other than charging is normally required for the battery. In case of a malfunctioning battery, the battery has to be replaced by skilled service personnel.

A fully discharged battery will be indicated by no light on the battery indicator LEDs

even when the button for battery check is depressed. The test has to be done without mains connected. If the battery is fully discharged the tapping machine has to be switched On for about 20 seconds to activate the fast charging. (Tip: Set the Normal/Remote switch to Remote if you don't want the motor to start.)

The Nor277 will stop functioning when the battery voltage gets too low. The unit is RPM controlled by means of a feedback system. Hence, a low battery voltage will not influence the tapping speed as long as the machine keeps running.

Programming the hand-switch

The supplied remote hand switch is pre-programmed for the supplied Nor277. Several hand switches can be programmed for one or more tapping machines or vice versa.

The procedure is as follows:

- Switch on Nor277 (Place the Normal/Remote switch in position Remote RS232 in order to stop the motor from running);
- Push a small rod (paperclip) into the tiny hole located above the switch marked radio to activate a push button (press shortly since pressing for more than 10 seconds will erase previously installed remote hand switches);
- Press and release the button located on the remote hand switch;
- Wait 10 seconds;
- Repeat the press and release on the remote hand switch;
- Wait 20 seconds;
- The hand switch is now programmed to the Nor277.

The remote communication is based on RS 232, which allows long cables between the computer and the tapping machine. The maximum length of cables will depend on the type of cable (capacitance) and the controlling device. It is therefore not possible to specify the maximum length, but up to 100 m has been used successfully.

If your computer does not have an RS 232 serial interface, we recommend connecting the tapping machine to the USB-port by using a commercially available USB/RS 232 adaptor.

An alternative to cable is to use a Bluetooth to RS 232 adapter. 5 volt for powering the module is available on pin 9.

All command consists of two characters (CAPITALS) followed by a space and eventually a parameter. All commands must be ended with carriage return <CR> (ascii 13). A line feed <LF> is ignored. If an unknown command is sent, the character “?” is returned.

Instructions for normal operation

Instruction	Command	Parameter	Notes
Identification	ID	None	Returns: Nor277<CR><LF>
Software version	SW	None	Returns software version number
Start	ST	None	Starts normal operation
Stop	SP	None	Stops the motor



Making Measurements

A measurement according to the ISO 140 part 7 will normally yield repeatable results when the room volume exceeds 25m³.

Do as follows:

1. Choose six positions at random on the floor. No position should be closer to the room boundaries (the walls) than 1.0 metre.

In cases of non-isotropic floor constructions (as will be the case with rib beam constructions), more positions may be required.

2. The Nor277 should be oriented at 45° to the direction of the beams or ribs
3. The measurement of impact noise is based on absolute sound level measurements (as opposed to e.g. the relative measurements used when capturing decays for reverberation time calculations). Hence, you should calibrate your measuring equipment before you start making measurements. Consult the documentation accompanying the rest of your equipment.
4. Measure the background noise level in the receiving room. Use a bandwidth of 1/3 octave bands in the range 100Hz to 3.15kHz. This is the standard range for building acoustics measurements.
5. In the sending room, start the tapping machine and verify that the excitation level is at least 10dB above the background noise level. Check this for each individual frequency band. If this requirement fails to be met, special precautions must be taken.
6. In the receiving room measure the sound level for the six different tapping machine positions. For each tapping machine

position in the sending room, one of six randomly distributed microphone positions is chosen in the receiving room.

The measuring time should always exceed 5 seconds.

No microphone position should be closer to the room boundaries than 0.5m.

Alternatively a rotating microphone boom (available separately from Norsonic AS) may be used. A minimum sweep radius of 0.7 metre is then required. The plane of the traverse should be inclined relative to the room boundaries and the microphone should never be closer to any of the room boundaries than 0.5 metre.

The averaging time when measuring with a rotating boom should be equal to the traverse time of the boom, but never shorter than 30 seconds.

7. Sequentially select, measure and average the results from the other tapping machine positions in order to average out local phenomena.
8. Measure the reverberation times for the individual 1/3 octave band frequencies in the receiving room. At least three positions are required and at least two measurements should be made in each position.

The equivalent absorption area A may now be calculated from $A = [0.163 \times V]/T$ and the normalised impact sound pressure level L'_n may then be calculated from:

$$L'_n = L_1 + 10 \times \log(A/A_0) \text{ [dB]}$$

in which A_0 equals 10m². You will now be able to calculate $L_{n,w}$ as described in ISO 717.

SENDING ROOM

Use altogether six randomly selected positions on the floor.

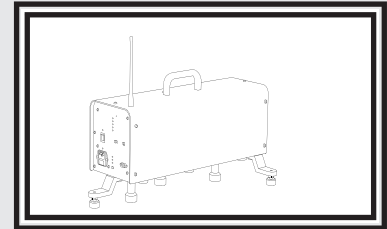

The tapping machine should be oriented 45° to the direction of beams or ribs

RECEIVING ROOM

Use one of six randomly selected microphone positions per tapping machine location, or use a rotating boom

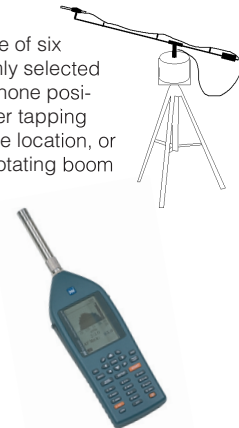

Hammers:

Five in line, (100 ± 1) mm between each hammer

Single hammer weight: (500 ± 4) g

Diameter: 30 ± 0.2 mm

Face curvature: 500 ± 10 mm

Effective fall height: 40 mm (adjustable ± 5 mm). Extra drop below impact plane (40 mm) is at least 4 mm.

Tapping frequency:

Each hammer 2 times per second, Sequence: 1-3-5-2-4

Mean Time between impacts: 100 ± 5 ms

Successive time between impacts: 100 ± 20 ms

Power:

85 – 264 VAC, 47 – 63 Hz, Fuse: 2A

Power consumption: Max 30 W

Battery operation (Option 1):

Operation from built-in Lithium-Ion rechargeable battery.

Battery operating time: More than 1 hour, typical 1,5 hours continuous/intermittent operation.

Battery charging time: 2 hours (Machine in Off). The battery is automatically charged when the unit is connected to the mains input.

Digital interface: RS232, 9600 baud

Connector: 9-pin Sub D

Supplied power: 5 volt on pin 9 for supply of external modules, max 50 mA.

Dimensions and weight

WxHxD feet retracted: 165x230x495 mm (6,5x9,1x19,5")

WxHxD feet extended: 265x230x495 mm (10,4x9,1x19,5")
+50 mm (H) including handle (2")

10 kg (22 lbs)

Environmental

Operation: -10 to +40 deg C, < 90% RH

Storage: -30 to + 70 deg C, < 90%RH

CE conformity

EMC compliance according to EN50081-1 and EN50082-1

Safety according to EN61010-1 and Machine directive 89/392

Options:

Option 1: Battery operation

Option 2: Remote Control

Transmitting Frequency:

433,92 MHz, CE compliant for use in Europe.

315 MHz, FCC compliant for use in USA.

Transmitting range: 100m (USA: 50m)

Accessories included:

Mains cable

13 mm wrench

Gauge for height adjustment

Optional accessories:

Carrying/Shipping Case Nor1336

Nor277 fulfil the requirements in the following standards:

- ISO 140 – 6 (1998): Acoustics -- Measurement of sound insulation in buildings and of building elements -- Part 6: Laboratory measurements of impact sound insulation of floors
- ISO 140 – 7 (1998): Acoustics -- Measurement of sound insulation in buildings and of building elements -- Part 7: Field measurements of impact sound insulation of floors
- ISO 140 – 8 (1997): Acoustics -- Measurement of sound insulation in buildings and of building elements -- Part 8: Laboratory measurements of the reduction of transmitted impact noise by floor coverings on a heavyweight standard floor
- ASTM E492-04: Standard Test Method for Laboratory Measurement of Impact Sound Transmission Through Floor-Ceiling Assemblies Using the Tapping Machine
- ASTM E1007-04e1: Standard Test Method for Field Measurement of Tapping Machine Impact Sound Transmission Through Floor-Ceiling Assemblies and Associated Support Structures

Specifications subject to change without further notice.

Declaration of Conformity

We, Norsonic AS, Gunnersbråtan 2, Tranby, Norway, declare under our sole responsibility that the product:

Tapping Machine NOR277

to which this declaration relates, is in conformity with the following standards or other normative documents:

Safety: EN61010-1:Februar 2001 for portable equipment and pollution category 2.

EMC: EN 6100-6-3; 2001
EN 6100-6-2; 2005

following the provisions of the EU Machine Directive 98/37/EC of 22. June 1998.

Configuration for test: Connected to public power supply, machine running, 2 m cable connected to RS232

This product has been manufactured in compliance with the provisions of the relevant internal Norsonic production standards.
All our products are tested individually before they leave the factory.

This Declaration of Conformity does not affect our warranty obligations.

Tranby, November 2007



Dagfinn Jahr
Quality Manager

The declaration of conformity is given according to EN 45014 and ISO/IEC Guide 22.

Norsonic AS, P.O. Box 24, N-3420 Lierskogen, Norway



P.O. Box 24
N-3421 Lierskogen
Norway
Tel: +47 3285 8900
Fax: +47 3285 2208
info@norsonic.com
www.norsonic.com

Norsonic AS supplies a complete range of instrumentation for acoustics – from sound calibrators, microphones & preamplifiers; via small hand-held sound level meters to advanced, yet portable, real time analysers, but also building acoustics analysers and complete community, industry and airport noise monitoring systems. Contact your local representative or the factory for information on our complete range of instrumentation.