

Programmable Logic Controllers

USER'S MANUAL

Networking

[CONTENTS](#)

OIS PLUS
Operator Interface Stations

Toshiba International Corporation

Thank you for purchasing the OIS PLUS (Operator Interface Stations) product from Toshiba International Corp. OIS PLUS Series products are versatile industrial displays which are configured with Microsoft Windows® based software.

Manual's Purpose and Scope

This manual provides information on how to safely install, operate, and maintain your OIS PLUS. This manual includes a section of general safety instructions that describes the warning labels and symbols that are used throughout the manual. Read the manual completely before installing, operating, or performing maintenance on this equipment. This manual and the accompanying drawings should be considered a permanent part of the equipment and should be readily available for reference and review. Dimensions shown in the manual are in metric and/or the English equivalent.

Toshiba International Corporation reserves the right, without prior notice, to update information, make product changes, or to discontinue any product or service identified in this publication.

TOSHIBA is a registered trademark of the Toshiba Corporation. All other product or trade references appearing in this manual are registered trademarks of their respective owners.

Toshiba International Corporation (TIC) shall not be liable for technical or editorial omissions or mistakes in this manual, nor shall it be liable for incidental or consequential damages resulting from the use of information contained in this manual.

This manual is copyrighted. No part of this manual may be photocopied or reproduced in any form without the prior written consent of Toshiba International Corporation.

Toshiba International Corporation.

All rights reserved.

Printed in the U.S.A.

Important Notice

The instructions contained in this manual are not intended to cover all details or variations in equipment types, nor may it provide for every possible contingency concerning the installation, operation, or maintenance of this equipment. Should additional information be required contact your Toshiba representative.

The contents of this manual shall not become a part of or modify any prior or existing agreement, commitment, or relationship. The sales contract contains the entire obligation of Toshiba International Corporation. The warranty contained in the contract between the parties is the sole warranty of Toshiba International Corporation and any statements contained herein do not create new warranties or modify the existing warranty.

Any electrical or mechanical modifications to this equipment without prior written consent of Toshiba International Corporation will void all warranties and may void the 3rd party (CE, UL, CSA, etc.) safety certifications. Unauthorized modifications may also result in a safety hazard or equipment damage.

Contacting Toshiba's Customer Support Center

Toshiba's Customer Support Center may be contacted to obtain help in resolving any system problems that you may experience or to provide application information. The center is open from 8 a.m. to 5 p.m. (CST), Monday through Friday. The Support Center's toll free number is US 800-231-1412 Fax 713-466-8773 — Canada 800-527-1204 — Mexico 01-800-527-1204.

You may also contact Toshiba by writing to:

Toshiba International Corporation
13131 West Little York Road
Houston, Texas 77041-9990
Attn: PLC Marketing

Or email

plc@tic.toshiba.com.

For further information on Toshiba's products and services, please visit our website at www.toshiba.com/ind/.

Manual Revisions

Please have the following information available when contacting Toshiba International Corp. about this manual.

Name: Networking Manual

Document: UM-OISPLUS-E003

Revision:

<u>Rev No.</u>	<u>Date</u>	<u>Description</u>
0	2012/02/14	Initial Issue (for V200)
1	2012/03/20	Added I/O Mapping
2	2012/4/13	Added Engineering Corrections

Related Manuals

UM-OISPLUS-E001: Hardware & Specifications

UM-OISPLUS-E002: Display Programming

UM-OISPLUS-E004: Universal Serial (ASCII) Driver

UM-V200-E001: Setup and Operation (for ladder logic programming)

UM-V200-E002: Ladder Logic (how to use the ladder instructions)

Table of Contents

0.1 Warning Labels Within Manual	3
0.2 Equipment Warning Labels.	5
0.3 Preparation.....	6
0.4 Installation Precautions	7
0.5 Connection, Protection & Setup.....	9
0.6 System Integration Precautions.....	11
0.7 3 rd Party Safety Certifications.	12
Serial Networking.....	13
1.1 Modbus RTU Master Setup.....	15
1.1.1 Define the OIS45E PLUS Network	16
1.1.2 Enter OIS45E PLUS Tags.....	17
1.1.3 Create the OIS45E PLUS Screens.....	18
1.2 Modbus RTU Slave Setup.....	21
1.2.1 Define the V200 Network	22
1.2.2 Enter V200 Tags	23
1.2.3 Program Ladder Logic in the V200.....	27
1.2.4 Ladder Logic Programming with Modbus Tags.....	29
Ethernet Networking	30
2.1 Modbus Client Setup	33
2.1.1 Define the OIS45E PLUS Network	34
2.1.2 Enter OIS45E PLUS Tags.....	36
2.1.3 Create the OIS45E PLUS Screens.....	38
2.2 Modbus Server Setup.....	41
2.2.1 Define the V200 Network	42
2.2.2 Enter V200 Tags	44
2.2.3 Program Ladder Logic in the V200.....	48
2.2.4 Ladder Logic Programming with Modbus Tags.....	49
Physical Connections	50
3.1 Modbus Serial Connections.....	51
3.2 Modbus Ethernet Connections	54

0. General Safety Instructions and Information

- [Warning Labels Within Manual](#)
- [Equipment Warning Labels](#)
- [Preparation](#)
- [Installation Precautions](#)
- [Connection, Protection & Setup](#)
- [System Integration Precautions](#)
- [3rd Party Safety Certifications](#)

0.1 Warning Labels Within Manual

DO NOT attempt to install, operate, maintain, or dispose of this equipment until you have read and understood all of the product warnings and user directions that are contained in this instruction manual.

Listed below are the signal words that are used throughout this manual followed by their descriptions and associated symbols. When the words **DANGER**, **WARNING**, and **CAUTION** are used in the manual, they will be followed by important safety information that must be carefully adhered to.

DANGER — The danger symbol is an exclamation mark enclosed in a triangle that precedes the word **DANGER**. The danger symbol is used to indicate an imminently hazardous situation that will result in serious injury, possible severe property and equipment damage, or death if the instructions are not followed.



WARNING — The warning symbol is an exclamation mark enclosed in a triangle that precedes the word **WARNING**. The warning symbol is used to indicate a potentially hazardous situation that can result in serious injury, or possibly severe property and equipment damage, or death, if the instructions are not followed.



CAUTION — The caution symbol is an exclamation mark enclosed in a triangle that precedes the word **CAUTION**. The caution symbol is used to indicate situations that can result in minor or moderate operator injury, or equipment damage if the instructions are not followed.



To identify special hazards, other symbols may appear in conjunction with the **DANGER**, **WARNING**, and **CAUTION** symbols. These warnings describe areas that require special care and/or strict adherence to the procedures to prevent serious injury and possible death.

Electrical Hazard — The electrical hazard symbol is a lightning bolt enclosed in a triangle. The electrical hazard symbol is used to indicate high voltage locations and conditions that may cause serious injury or death if the proper precautions are not observed.



Explosion Hazard — The explosion hazard symbol is an explosion image enclosed in a triangle. The explosion hazard symbol is used to indicate locations and conditions where molten exploding parts may cause serious injury or death if the proper precautions are not observed.



0.2 Equipment Warning Labels.

DO NOT attempt to install, operate, maintain, or dispose of this equipment until you have read and understood all of the product warnings and user directions that are contained in this instruction manual.

Shown below are examples of warning labels that may be found attached to the equipment. **DO NOT** remove or cover any of the labels. If the labels are damaged or if additional labels are required, contact your Toshiba representative for additional labels.

The following are examples of the warning labels that may be found on the equipment and are there to provide useful information or to indicate an imminently hazardous situation that may result in serious injury, severe property and equipment damage, or death if the instructions are not followed.

Examples of labels that may be found on the equipment.



0.3 Preparation

Qualified Person

A **Qualified Person** is one that has the skills and knowledge relating to the construction, installation, operation, and maintenance of the electrical equipment and has received safety training on the hazards involved (Refer to the latest edition of NFPA 70E for additional safety requirements).

Qualified Personnel shall:

- Have carefully read the entire operation manual.
- Be trained and authorized to safely energize, de-energize, ground, lockout and tag circuits and equipment, and clear faults in accordance with established safety practices.
- Be trained in the proper care and use of protective equipment such as safety shoes, rubber gloves, hard hats, safety glasses, face shields, flash clothing, etc., in accordance with established safety practices.
- Be trained in rendering first aid.

For further information on workplace safety visit www.osha.gov.

Equipment Inspection

- Upon receipt of the equipment inspect the packaging and equipment for shipping damage.
- Carefully unpack the equipment and check for parts that were damaged from shipping, missing parts, or concealed damage. If any discrepancies are discovered, it should be noted with the carrier prior to accepting the shipment, if possible. File a claim with the carrier if necessary and immediately notify your Toshiba representative.
- **DO NOT** install or energize equipment that has been damaged. Damaged equipment may fail during operation resulting in further equipment damage or personal injury.
- Check to see that the model number specified on the nameplate conforms to the order specifications.
- Modification of this equipment is dangerous and must not be performed except by factory trained representatives. When modifications are required contact your Toshiba representative.
- Inspections may be required before and after moving installed equipment.
- Keep the equipment in an upright position as indicated on the shipping carton.
- Contact your Toshiba representative for assistance if required.

- Handling and Storage
- Use proper lifting techniques when moving the OIS; including properly sizing up the load, and getting assistance if required.
- Store in a well-ventilated covered location and preferably in the original carton if the equipment will not be used upon receipt.
- Store in a cool, clean, and dry location. Avoid storage locations with extreme temperatures, rapid temperature changes, high humidity, moisture, dust, corrosive gases, or metal particles.
- Do not store the unit in places that are exposed to outside weather conditions (i.e., wind, rain, snow, etc.).
- Store in an upright position as indicated on the shipping carton.
- Include any other product-specific requirements.

Disposal

Never dispose of electrical components via incineration. Contact your state environmental agency for details on disposal of electrical components and packaging in your area.

0.4 Installation Precautions

Location and Ambient Requirements

- Adequate personnel working space and adequate illumination must be provided for adjustment, inspection, and maintenance of the equipment (refer to NEC Article 110-34).
- Avoid installation in areas where vibration, heat, humidity, dust, fibers, steel particles, explosive/corrosive mists or gases, or sources of electrical noise are present.
- The installation location shall not be exposed to direct sunlight.
- Allow proper clearance spaces for installation. Do not obstruct the ventilation openings. Refer to the recommended minimum installation dimensions as shown on the enclosure outline drawings.
- The ambient operating temperature shall be between 0° and 50° C (32° and 122° F).

Mounting Requirements

- Only **Qualified Personnel** should install this equipment.
- Install the unit in a secure upright position in a well-ventilated area.
- A noncombustible insulating floor or mat should be provided in the area immediately surrounding the electrical system at the place where maintenance operations are to be performed.
- As a minimum, the installation of the equipment should conform to the NEC Article 110 Requirements For Electrical Installations, OSHA, as well as any other applicable national, regional, or industry codes and standards.
- Installation practices should conform to the latest revision of NFPA 70E Electrical Safety Requirements for Employee Workplaces.

Conductor Routing and Grounding

- Use separate metal conduits for routing the input power, and control circuits.
- A separate ground cable should be run inside the conduit with the input power, and control circuits.
- **DO NOT** connect control terminal strip return marked CC to earth ground.
- Always ground the unit to prevent electrical shock and to help reduce electrical noise.

The Metal Of Conduit Is Not An Acceptable Ground.

0.5 Connection, Protection & Setup

Personnel Protection

- Installation, operation, and maintenance shall be performed by **Qualified Personnel Only**.
- A thorough understanding of the OIS will be required before the installation, operation, or maintenance of the OIS.
- Rotating machinery and live conductors can be hazardous and shall not come into contact with humans. Personnel should be protected from all rotating machinery and electrical hazards at all times. Depending on its program, the OIS can initiate the start and stop of rotating machinery.
- Insulators, machine guards, and electrical safeguards may fail or be defeated by the purposeful or inadvertent actions of workers. Insulators, machine guards, and electrical safeguards are to be inspected (and tested where possible) at installation and periodically after installation for potential hazardous conditions.
- Do not allow personnel near rotating machinery. Warning signs to this effect shall be posted at or near the machinery.
- Do not allow personnel near electrical conductors. Human contact with electrical conductors can be fatal. Warning signs to this effect shall be posted at or near the hazard.
- Personal protection equipment shall be provided and used to protect employees from any hazards inherent to system operation or maintenance.

System Setup Requirements

- When using the OIS as an integral part of a larger system, it is the responsibility of the OIS installer or maintenance personnel to ensure that there is a fail-safe in place (i.e., an arrangement designed to switch the system to a safe condition if there is a fault or failure).
- System safety features should be employed and designed into the integrated system in a manner such that system operation, even in the event of system failure, will not cause harm or result in personnel injury or system damage (i.e., E-Off, Auto-Restart settings, System Interlocks, etc.).
- The programming setup and system configuration of the OIS may allow it to start a motor unexpectedly. A familiarity with Auto-restart settings is a requirement to use this product.
- Improperly designed or improperly installed system interlocks may render the motor unable to start or stop on command.

The failure of external or ancillary components may cause intermittent system operation, i.e., the system may start a motor without warning or may not stop on command.

- There may be thermal or physical properties, or ancillary devices integrated into the overall system that may allow the OIS to start a motor without warning. Signs at the equipment installation must be posted to this effect.
- The operating controls and system status indicators should be clearly readable and positioned where the operator can see them without obstruction.
- Additional warnings and notifications shall be posted at the equipment installation location as deemed required by **Qualified Personnel**.

0.6 System Integration Precautions

The following precautions are provided as general guidelines for using an OIS in an industrial or process control system.

- The Toshiba PLC is a general-purpose product. It is a system component and is used in conjunction with other items of industrial equipment such as PLCs, Loop Controllers, Adjustable Speed Drives, etc.
- **A detailed system analysis and job safety analysis should be performed by the systems designer or systems integrator before including the OIS in any new or existing system.** Contact Toshiba for options availability and for application-specific system integration information if required.
- The PLC may be used to control an adjustable speed drive connected to high voltage sources and rotating machinery that is inherently dangerous if not operated safely. Interlock all energy sources, hazardous locations, and guards in order to restrict the exposure of personnel to hazards. The adjustable speed drive may start the motor without warning. Signs at the equipment installation must be posted to this effect. A familiarity with Auto-restart settings is a requirement when controlling adjustable speed drives. Failure of external or ancillary components may cause intermittent system operation, i.e., the system may start the motor without warning or may not stop on command. **Improperly designed or improperly installed system interlocks and permissives may render a motor unable to start or stop on command**
- Control through serial communications can fail or can also override local controls, which can create an unsafe condition. System safety features should be employed and designed into the integrated system in a manner such that system operation, even in the event of system failure, will not cause harm or result in personnel injury or system damage. Use of the built-in system protective features and interlocks of the equipment being controlled is highly recommended (i.e., emergency-off, overload protection, etc.)
- **Never use the PLC units to perform emergency stops.** Separate switches outside the OIS, the PLC, and the ASD should be used for emergency stops.
- Changes or modifications to the PLC program should not be made without the approval of the system designer or systems integrator. Minor changes or modifications could cause the defeat of safety interlocks and permissives. Any changes or modifications should be noted and included with the system documentation.

0.7 3rd Party Safety Certifications.

CE Marking

The V200 Series Programmable Controllers conform to the directive and standards of ISO/IEC Guide 22 and EN 45014.

Conforms to the following Product Specifications

EMI(Electro Magnetic Interference) :	
Conducted*/Radiated	: EN61131-2:2007/EN55011
EMS(Electro Magnetic Susceptibility)	
ESD	: EN61131-2:2007/EN61000-4-2
RF EM field	: EN61131-2:2007/EN61000-4-3
Fast Transient	: EN61131-2:2007/EN61000-4-4
Surge Immunity	: EN61131-2:2007/EN61000-4-5
Conducted Disturbances	: EN61131-2:2007/EN61000-4-6
Magnetic Field Immunity **	: EN61131-2:2007/EN61000-4-8
Voltage dips & Interruptions*	: EN61131-2:2007/EN61000-4-11
Electrical Safety	: EN61131-2: 2007

UL Certification

The UL Mark on a product means that UL has tested and evaluated representative samples of that product and determined that they meet UL requirements. The basic standards used to investigate this category are UL 508, the Standard of Safety for Industrial Control Equipment and UL Standard for Safety for Programmable Controllers. V200 Programmable Logic Controllers are certified NRAG &NRAG7 for use in hazardous locations



Search results

You may choose to [Refine Your Search.](#)

Company Name	Category Name	Link to File
TOSHIBA CORP	Programmable Controllers for Use in Hazardous Locations	NRAG.E184034
TOSHIBA CORP	Programmable Controllers for Use in Hazardous Locations Certified for Canada	NRAG7.E184034

RoHS Product Certification

The V200 Series PLCs meet the European Directive on the Restriction of Hazardous Substances (RoHS) in electrical and electronic equipment companies This insures the chemical compliance of the V200.

Serial Networking

- ◆ Modbus RTU Master
- ◆ Modbus RTU Slave

It is possible to connect up to 32 devices together on a serial network as long as all devices have the same communications protocol. A common example would be several Toshiba ASD (adjustable speed drives/inverters) connected to an OIS PLUS display. In this case, all devices would communicate using Toshiba's native ASD ASCII protocol.

Often times it is necessary to connect several devices from different manufacturers. In this case the Modbus protocol is used since most manufacturers offer this as an option. An example of this is as shown below:

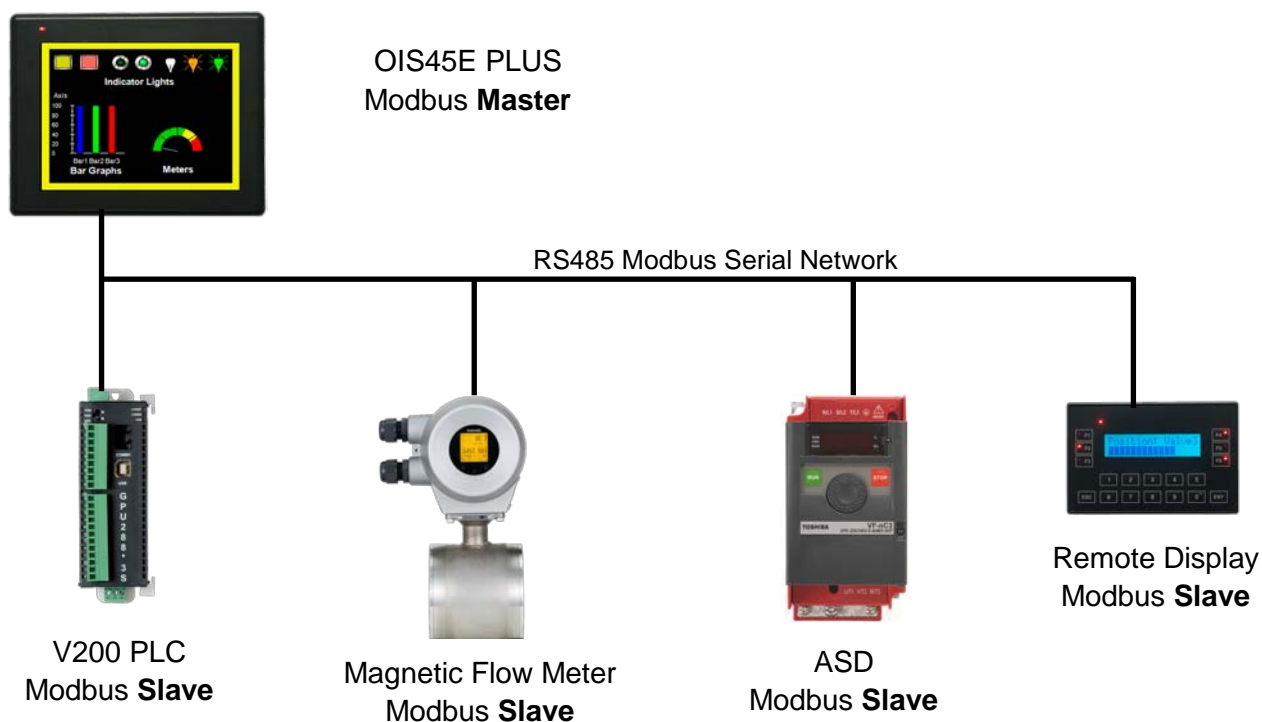

The following example will show how to setup a Modbus master and the Modbus slaves. For simplicity the example will only show setting up the V200 PLC as the Modbus slave. However, setting up the other slaves is very similar.

The example will be a proof of communications example. There are two parts to the example. In part 1, the OIS45E PLUS will be setup to monitor special timing ON/OFF bits in the V200 PLC.

Duty Cycle	V200 Address	OIS PLUS Modbus Address
0.4 Sec	M00482	035483
0.8 Sec	M00483	035484
1.0 Sec	M00484	035845
2.0 Sec	M00485	035846

The significance of the Modbus addresses will be explained when the slave is setup.

In part 2 a simple loop-back test will be done. A number will be entered into D1 on the OIS45E PLUS. That number will be sent to the V200, moved from D0 (450001) to D1 (450002) in the V200, and read back in the OIS45E PLUS.

When this example is setup and executing properly, it proves:

- ◆ Cabling is correct.
- ◆ Protocols are set correctly
- ◆ Communication parameters match
- ◆ Modbus register/device mapping is correct.
- ◆ Both devices are operating correctly.

For a detailed understanding of serial networking, it is recommend that both Modbus master and slave examples be studied carefully before any setup/programming is started.

1.1 Modbus RTU Master Setup

Open the OIL-DS software, click on New Project and select the OIS45E PLUS

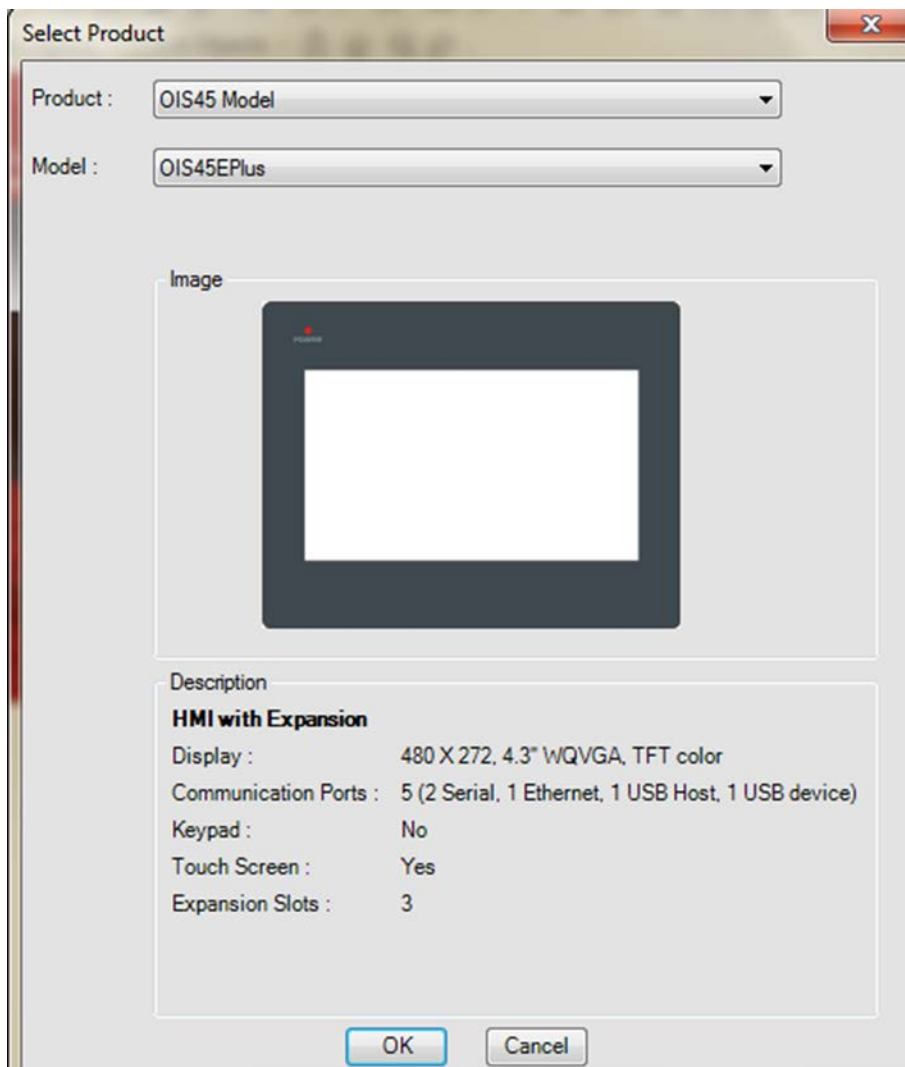

1.1.1 Define the OIS45E PLUS Network

Go to the navigation pane and define the network

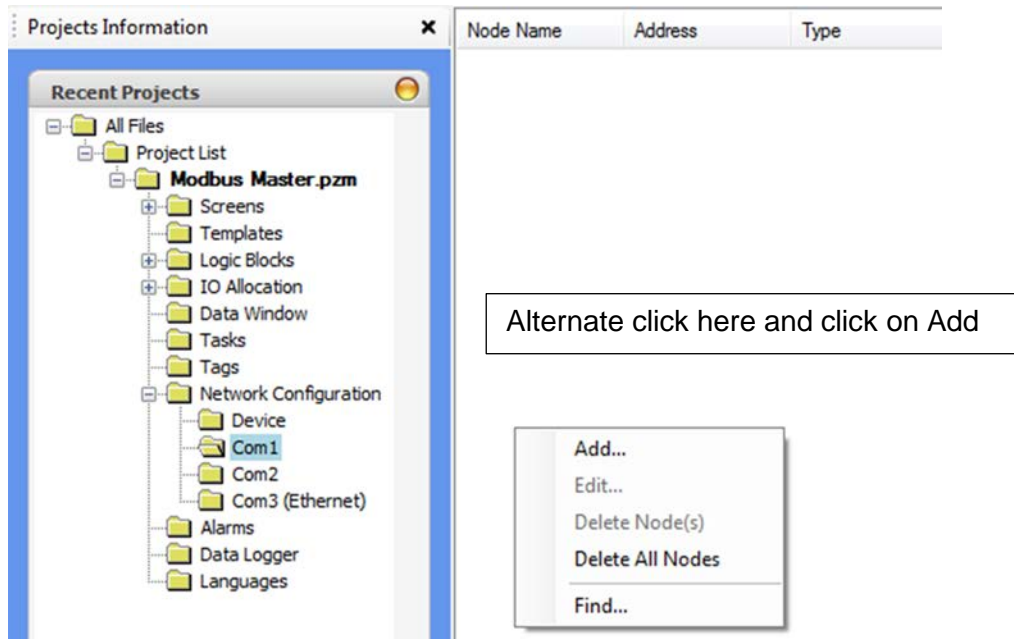

Setup the Node 1 as shown:

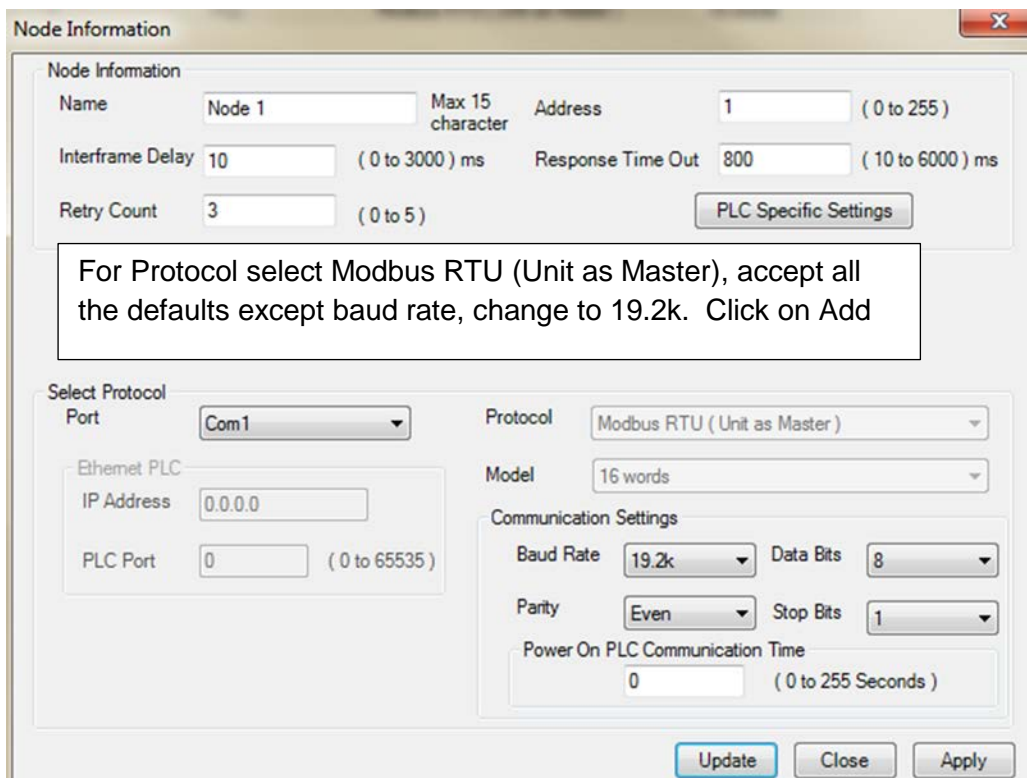

Com1 on the OIS45E PLUS is now setup as the Modbus master.

1.1.2 Enter OIS45E PLUS Tags

The next step is to assign Tags to the Modbus Master. In the Navigator Pane, click on Tags, the default tags assigned to the OIS45E PLUS are displayed automatically.

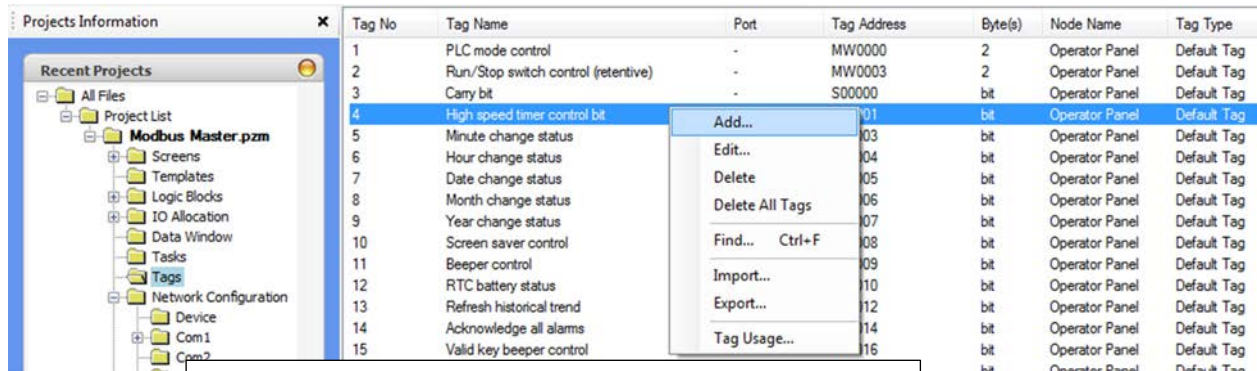

The screenshot shows a 'Projects Information' window with a 'Recent Projects' tree on the left and a table of tags on the right. The 'Tags' folder is selected in the tree. The table lists 15 tags with columns for Tag No, Tag Name, Port, Tag Address, Byte(s), Node Name, and Tag Type. A context menu is open over the tag 'High speed timer control bit' (Tag No 4), with the 'Add...' option highlighted.

Tag No	Tag Name	Port	Tag Address	Byte(s)	Node Name	Tag Type
1	PLC mode control	-	MW0000	2	Operator Panel	Default Tag
2	Run/Stop switch control (retentive)	-	MW0003	2	Operator Panel	Default Tag
3	Carry bit	-	S00000	bit	Operator Panel	Default Tag
4	High speed timer control bit	-	01	bit	Operator Panel	Default Tag
5	Minute change status	-	03	bit	Operator Panel	Default Tag
6	Hour change status	-	04	bit	Operator Panel	Default Tag
7	Date change status	-	05	bit	Operator Panel	Default Tag
8	Month change status	-	06	bit	Operator Panel	Default Tag
9	Year change status	-	07	bit	Operator Panel	Default Tag
10	Screen saver control	-	08	bit	Operator Panel	Default Tag
11	Beeper control	-	09	bit	Operator Panel	Default Tag
12	RTC battery status	-	10	bit	Operator Panel	Default Tag
13	Refresh historical trend	-	12	bit	Operator Panel	Default Tag
14	Acknowledge all alarms	-	14	bit	Operator Panel	Default Tag
15	Valid key beeper control	-	16	bit	Operator Panel	Default Tag

Alternate click in the tags window and click on Add.

Make sure Node name is Node 1 Modbus RTU (Unit as Master), then enter the Modbus coil 35483 as shown:

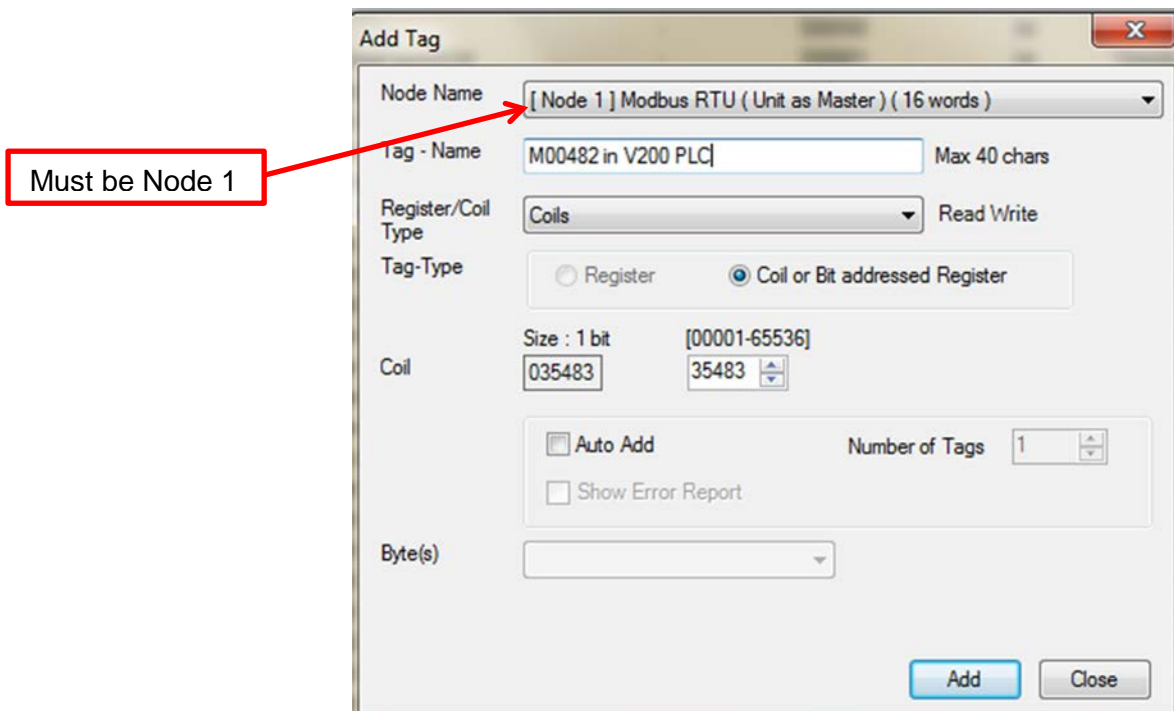

The 'Add Tag' dialog box is shown with the following fields and options:

- Node Name:** [Node 1] Modbus RTU (Unit as Master) (16 words)
- Tag - Name:** M00482 in V200 PLC] Max 40 chars
- Register/Coil Type:** Coils Read Write
- Tag-Type:** Register Coil or Bit addressed Register
- Coil:** Size : 1 bit [00001-65536] [035483] [35483]
- Auto Add:** **Number of Tags:** 1
- Show Error Report:**
- Byte(s):** []

A red box highlights the 'Node Name' field with the text 'Must be Node 1' and an arrow pointing to the dropdown menu.

Keep adding tags until all 6 of the tags shown below are added to Com1, Node 1:

72	M00482 (0.4 sec) in V200 PLC	Com1	035483	bit	Node 1	User Defined Tag
73	M00484 (0.8 sec) in V200 PLC	Com1	035484	bit	Node 1	User Defined Tag
74	M00485 (1.0 sec) in V200 PLC	Com1	035485	bit	Node 1	User Defined Tag
75	M00486 (2.0 sec) in V200 PLC	Com1	035486	bit	Node 1	User Defined Tag
76	D0000 in V200 PLC	Com1	450001	2	Node 1	User Defined Tag
77	D0001 in V200 PLC	Com1	450002	2	Node 1	User Defined Tag

Note: Additional tags can be added at any time later on.

1.1.3 Create the OIS45E PLUS Screens

Screens can now be created. In this example only one screen will be used. Create screen 1 as shown:

Special Timing Coils in V200 PLC



Loop Back Read from V200 PLC

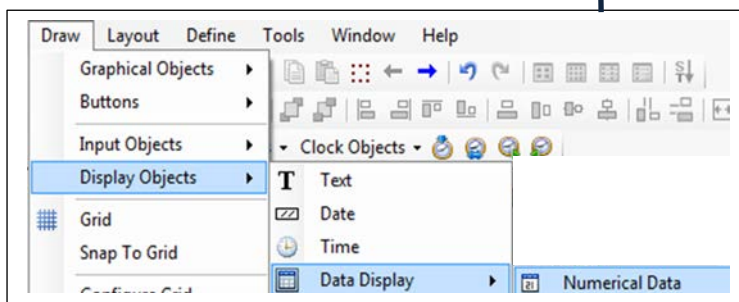
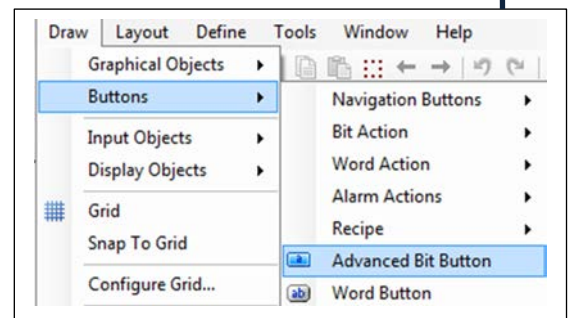
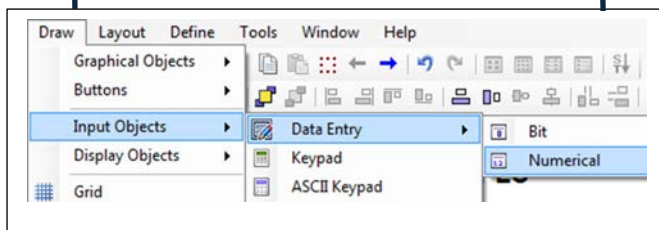

Now the tags can be attached to the screen objects. Often times it is easier to attach the tags to the objects as the objects are created. It can be done either way.

Select a button object.



Assign properties using the properties pane.

First select Feedback Tag. Then it is possible to select the ON image and the OFF image..

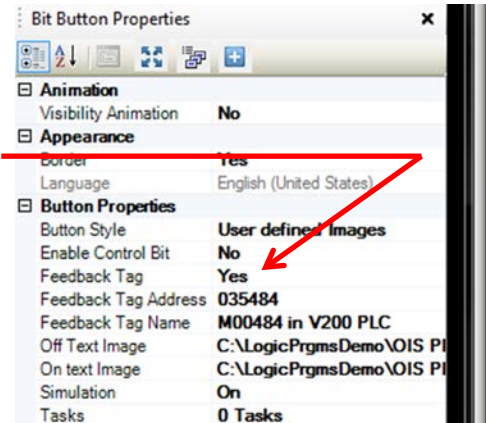

Select the input object.

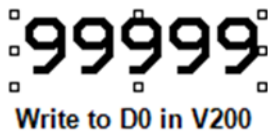

Pressing the data entry 99999 will cause the data entry keypad to appear. Key in a number and press enter

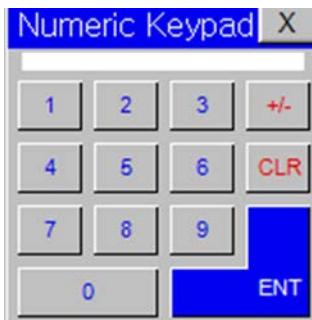

Make sure screen name, Numeric Keypad, is selected..

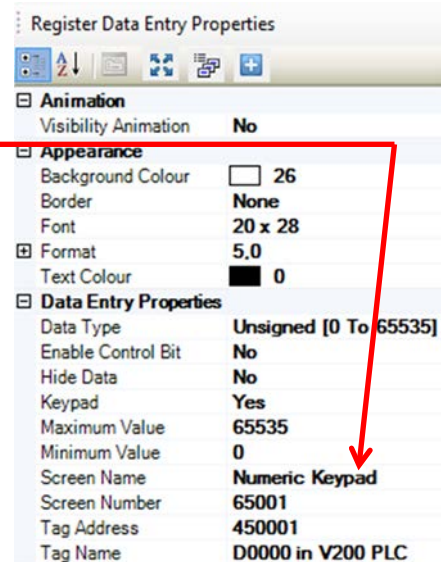

Select the data display object



Be sure to select the Modbus tag that is mapped to D0001 in the V200 PLC

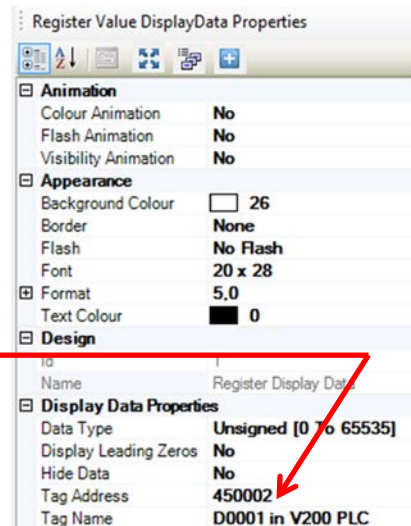

If desired, the beeper can be turned OFF for screen 1. Select the task under screen 1 and set it up as follows:

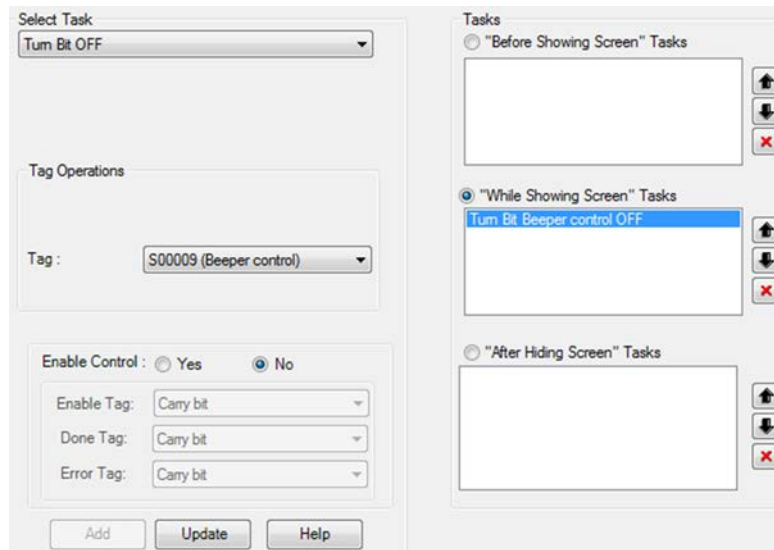

This completes setup of the Modbus RTU master.

1.2 Modbus RTU Slave Setup

Open the OIL-DS software if it is not already open, click on New Project and select the V200 PLC. Select the GPU288 model.



1.2.1 Define the V200 Network

Go to the navigation pane and define the network.

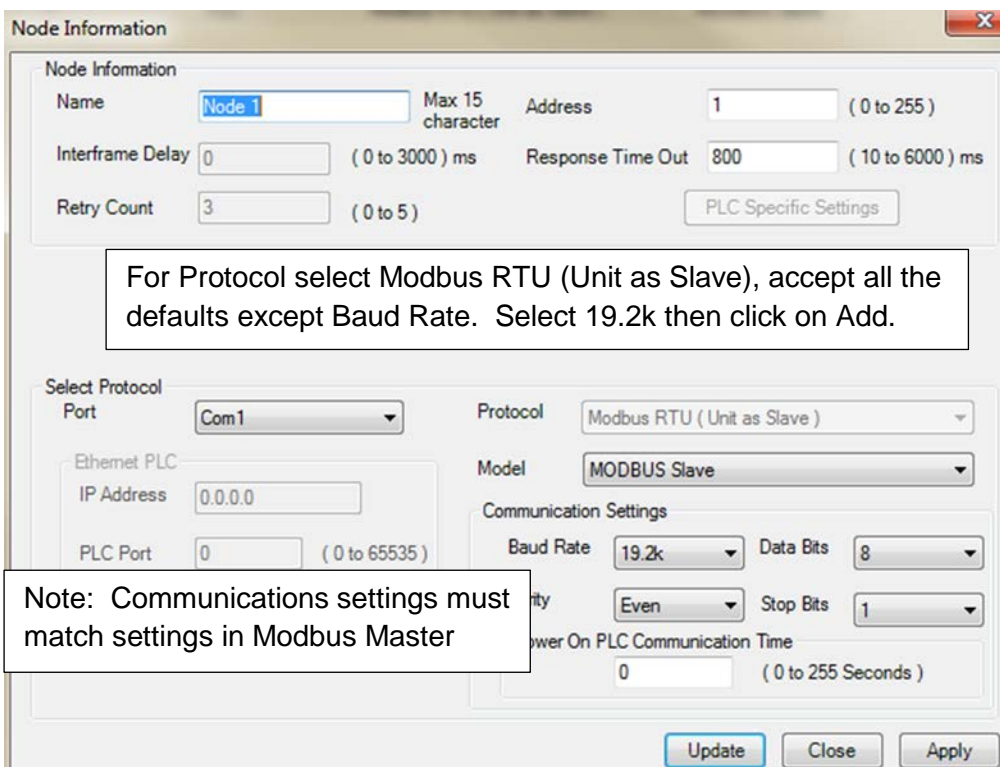
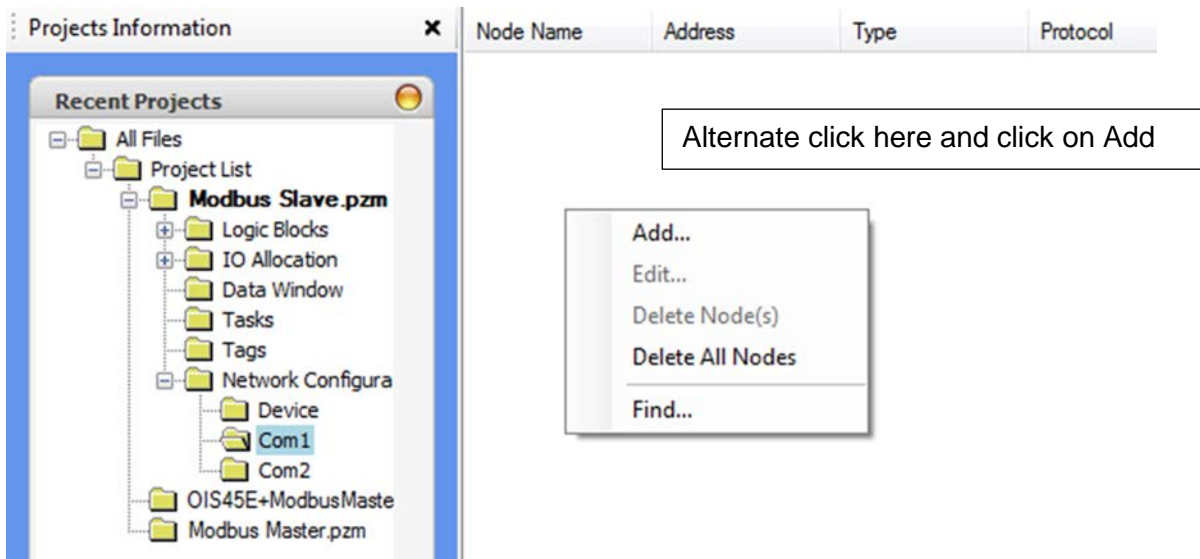

1.2.2 Enter V200 Tags

The next step is to assign Tags to the Modbus Slave. In the Navigator Pane, click on Tags, the default tags assigned to the V200 are displayed as shown.

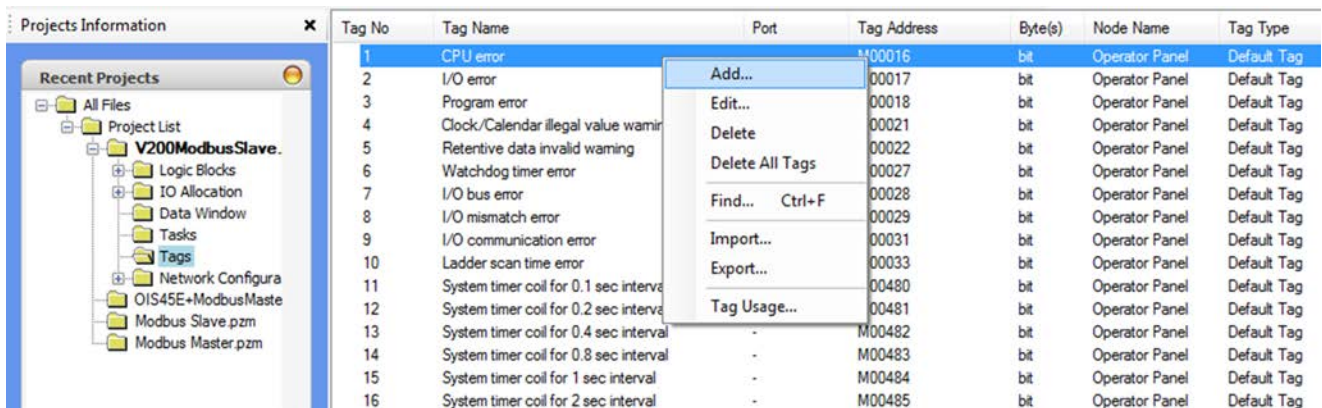

Tag No	Tag Name	Port	Tag Address	Byte(s)	Node Name	Tag Type
1	CPU error		M00016	bit	Operator Panel	Default Tag
2	I/O error		00017	bit	Operator Panel	Default Tag
3	Program error		00018	bit	Operator Panel	Default Tag
4	Clock/Calendar illegal value warning		00021	bit	Operator Panel	Default Tag
5	Retentive data invalid warning		00022	bit	Operator Panel	Default Tag
6	Watchdog timer error		00027	bit	Operator Panel	Default Tag
7	I/O bus error		00028	bit	Operator Panel	Default Tag
8	I/O mismatch error		00029	bit	Operator Panel	Default Tag
9	I/O communication error		00031	bit	Operator Panel	Default Tag
10	Ladder scan time error		00033	bit	Operator Panel	Default Tag
11	System timer coil for 0.1 sec interval		00480	bit	Operator Panel	Default Tag
12	System timer coil for 0.2 sec interval		00481	bit	Operator Panel	Default Tag
13	System timer coil for 0.4 sec interval		M00482	bit	Operator Panel	Default Tag
14	System timer coil for 0.8 sec interval		M00483	bit	Operator Panel	Default Tag
15	System timer coil for 1 sec interval		M00484	bit	Operator Panel	Default Tag
16	System timer coil for 2 sec interval		M00485	bit	Operator Panel	Default Tag

Alternate click in the tags window and click on Add.

Look closely at the default tags above. Note that the special timing bits, M00480 – M00487 are default tags, nothing more has to be done with them. But tags D0 and D1 must be created.

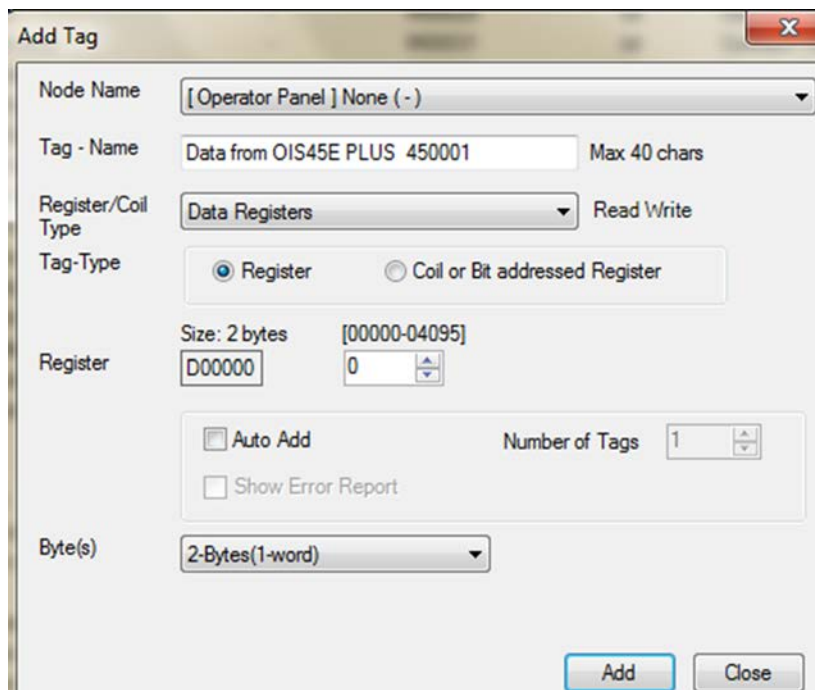

Add Tag

Node Name: [Operator Panel] None (-)

Tag - Name: Data from OIS45E PLUS 450001 (Max 40 chars)

Register/Coil Type: Data Registers (Read Write)

Tag-Type: Register Coil or Bit addressed Register

Register: D00000 (Size: 2 bytes, Range: [00000-04095])

Auto Add (Number of Tags: 1)

Show Error Report

Byte(s): 2-Bytes(1-word)

Buttons: Add, Close

Click Add. Then Add D1 in the same manner.

When complete the tag list should look as follows:

Tag No	Tag Name	Port	Tag Address	Byte(s)	Node Name	Tag Type
49	Data from OIS45E PLUS 450002	-	D00001	2	Operator Panel	UserDefined Tag
48	Data from OIS45E PLUS 450001	-	D00000	2	Operator Panel	UserDefined Tag

By this point a question should have arisen: How are the OIS45E PLUS and V200 registers mapped to Modbus registers? The answer is: It happens automatically when a com port is assigned as a Modbus slave. For the V200 the mapping is as follows:

Modbus Slave Mapping: OIS45E PLUS thru OIS120A & V200 PLCs.

Sr.No.	Register / Coil	Abv.	Tag Length	Range	Modbus Mapping
1	Timer Register (R/W)	T	2 Bytes	0000-0255	400001 - 400256
2	Counter Register (R/W)	C	2 Bytes	0000-0255	410001 - 410256
3	System Register (R/W)	SW	2 Bytes	0000-0255	420001 - 420256
4	Retentive Register (R/W)	R	2 Bytes	0000-1399	430001 - 431400
5	Input Register (R)	XW	2 Bytes	0000-0399	440001 - 440400
6	Output Register (R/W)	YW	2 Bytes	0000-0399	441001 - 441400
7	Internal Register (R/W)	BW	2 Bytes	0000-0255	442001 - 442256
8	Index Registers	I/J/K	2 Bytes	0000-0002	443001- 443003
9	Configuration Register	MW	2 Bytes	0000-1599	460001-461600
10	Data Register (R/W)	D	2 Bytes	0000-4095	450001 - 454096
11	Input Coil (R)	X	1 Bit	0000-6399	000001 - 006400
12	Output Coil (R/W)	Y	1 Bit	0000-6399	010001 - 016400
13	System Coil (R/W)	S	1 Bit	0000-0099	020001 - 020100
14	Internal Coil (R/W)	B	1 Bit	0000-4095	030001 - 034096
15	Timer Coil(R/W)	T.xxxx	1 Bit	0000-0255	021001-021256
16	Counter Coil(R/W)	C.xxxx	1 Bit	0000-0255	022001-022256
17	Configuration Coil(R/W)	M	1 Bit	00000-25599	035001- 060600

Notes:

1. Modbus register/coil tag length is the same as V200 register/coil tag length.
2. Each manufacturer has an equivalent table for their devices when they are designated a Modbus slave in a Modbus network. Without knowing the mapping between the slave devices internal registers/bits to the Modbus registers/bits, a Modbus network can not be established.

Modbus Slave Mapping: I/O Register Examples

Example 1: GPU288 8in/8out GDI216 16in GDD288 8in/8out

	Inputs	Outputs
CPU Slot	XW0000=440001	YW0000=441001
Slot 1	XW0100=440002	
Slot 2	XW0200=440003	YW0200=441002

Example 2: GPU288 8in/8out GAD208 8 AI GDD288 8in/8out

	Inputs	Outputs
CPU Slot	XW0000=440001	YW0000=441001
Slot 1	XW0100=440002 XW0101=440003 to XW0107=440009	
Slot 2	XW0200=440010	YW0200=441002

Example 3: GPU288 8in/8out GAA242 4 AI/2 AO GDD288 8in/8out

	Inputs	Outputs
CPU Slot	XW0000=440001	YW0000=441001
Slot 1	XW0100=440002 XW0101=440003 to XW0103=440005	YW0100=441002 YW0101=441003
Slot 2	XW0200=440006	YW0200=441004

Example 4: OIS PLUS TRPAIO0202L 2 AI/2 AO TRPOIO0808P 8 DI/8 DO

	Inputs	Outputs
OIS PLUS		
Slot 1	XW0100=440001	YW0100=441001
	XW0101=440002	YW0101=441002
Slot 2	XW0200=440003	YW0200=441003

Note: If a program was written and then one module is changed to a different type, all of the Modbus addressing to the right of the changed module will change

1.2.3 Program Ladder Logic in the V200

In order for the OIS45E PLUS data entered in D0 to loop back in D1, a MOV (move) instruction must be programmed in the V200. Open the ladder logic programming screen in the V200 PLC. Selecting Main Block 1 opens the programming pane.

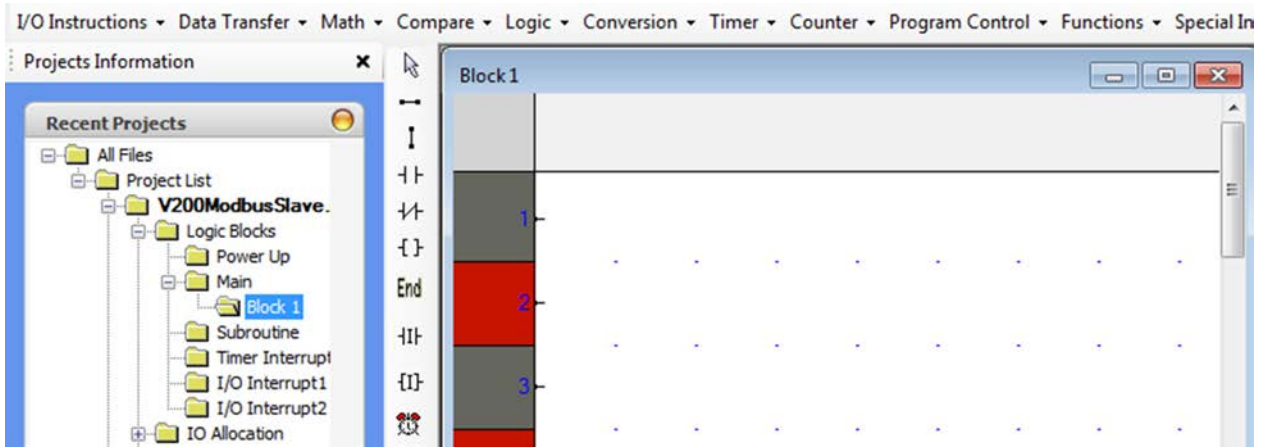

Create the following program. Go to Data Transfer and select the MOV instruction. Then add the END instruction

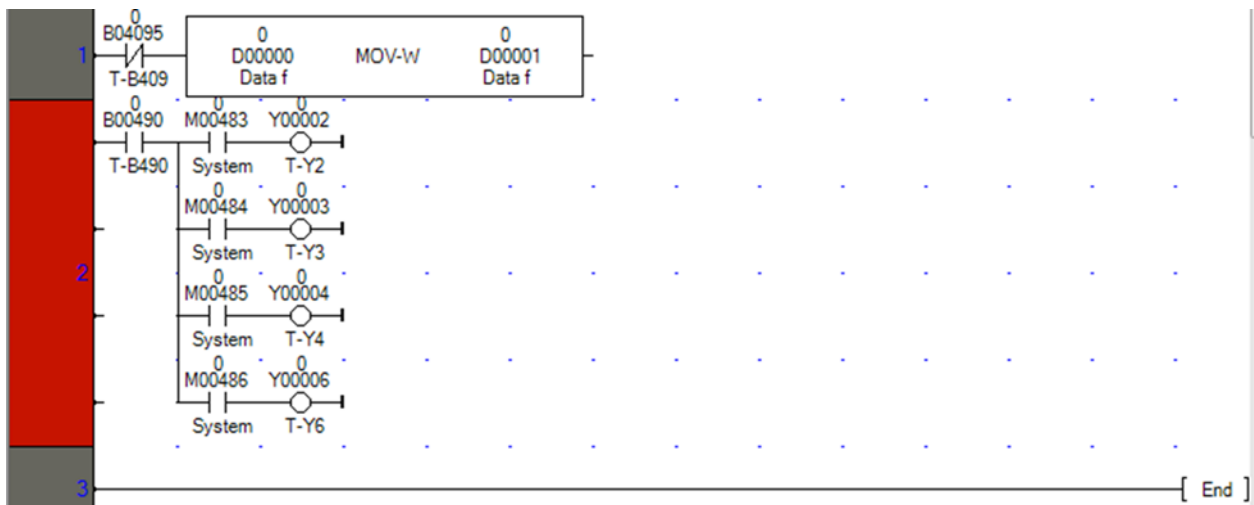

Note: Programming outputs Y00002 thru Y00006 is not necessary. But it does allow confirmation of the special M timing bits in the V200 PLC. These are the same timing bits that control the bit buttons on the OIS45E PLUS.

This completes setup of the V200 as a Modbus RTU slave.

The programs created for the OIS45E PLUS and the V200 PLC can be loaded into each device respectively. Please see Section 3, Physical Connections for cabling information. When everything is complete, it will then be possible to observe Modbus network communication between the Modbus RTU master and the Modbus RTU slave.

Again, it will confirm the following:

- ◆ Cabling is correct.
- ◆ Protocols are set correctly
- ◆ Communication parameters match
- ◆ Modbus register/device mapping is correct.
- ◆ Both devices are operating correctly.

1.2.4 Ladder Logic Programming with Modbus Tags

At this time it is not possible to use Modbus registers/devices directly in the ladder program. For example, in the OIS45E PLUS if it is necessary to multiply the value in Modbus register 450002 (D1 in the V200 PLC) by 10, 450002 cannot be used in the ladder logic program. **The following is not possible:**



Instead, the value in 450002 must be copied into one of the OIS45E PLUS's registers. This is done using a global task. Select Tasks from the navigation pane.

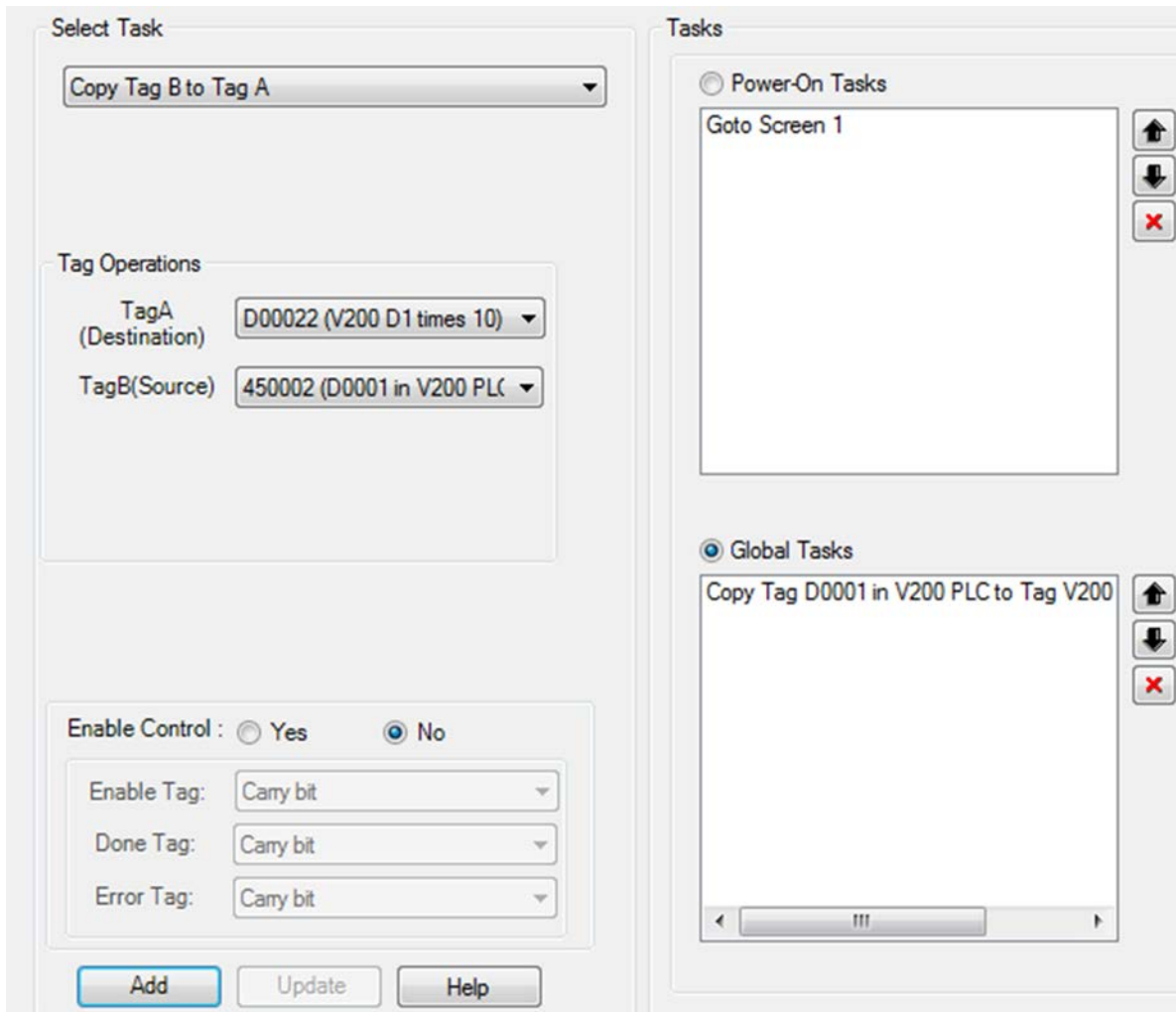

Now D22 can be used as an operand in the multiplication function block above. If a lot of registers from the V200 PLC need to be used in the OIS45E PLUS ladder program, Block Copy is available. A block of up to 999 continuous registers can be transferred with one Block Copy global task.

Ethernet Networking

- ◆ Modbus TCP/IP Client
- ◆ Modbus TCP/IP Server

Connecting industrial products together on an Ethernet network is becoming quite popular. Most manufactures off the option of connecting their industrial products on a Modbus TCP/IP network. A typical network would be as shown:

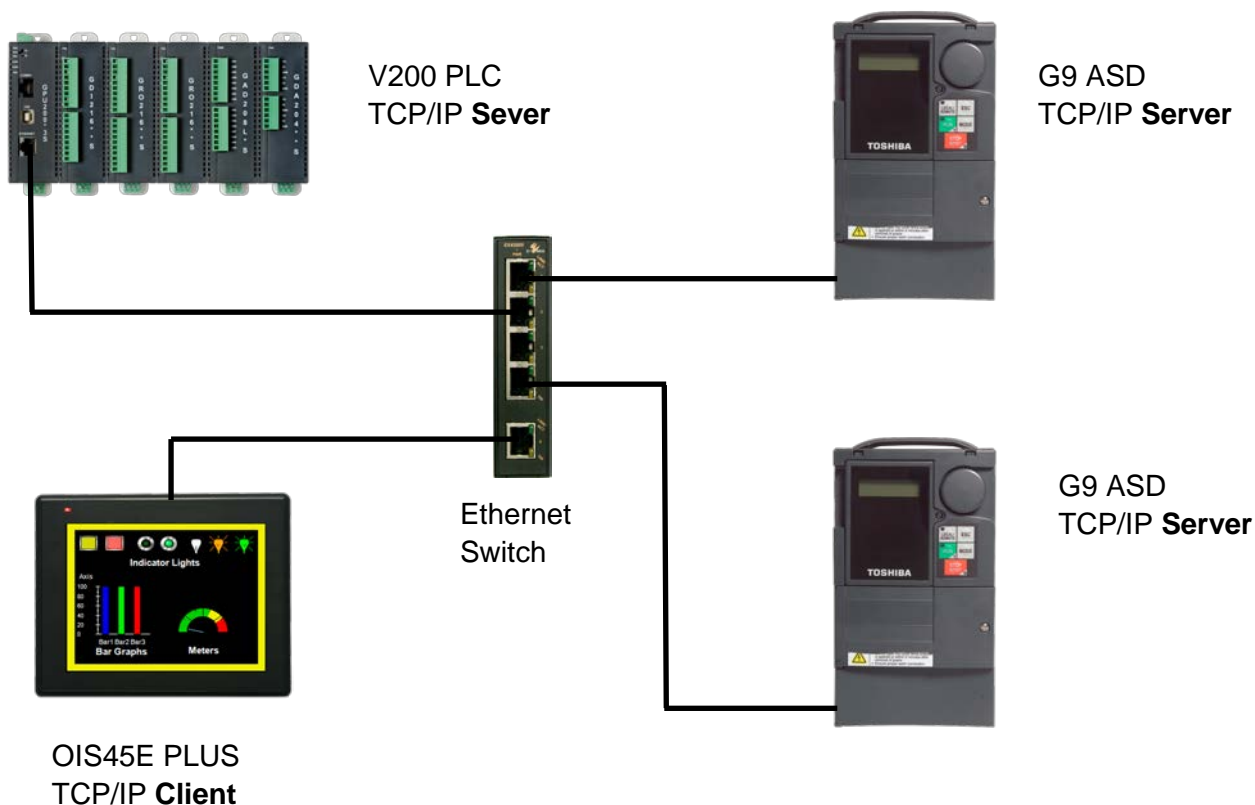

For the Ethernet Modbus TCP/IP network example, just one client and one server will be used. The objective is to show the setup and verify the communications.

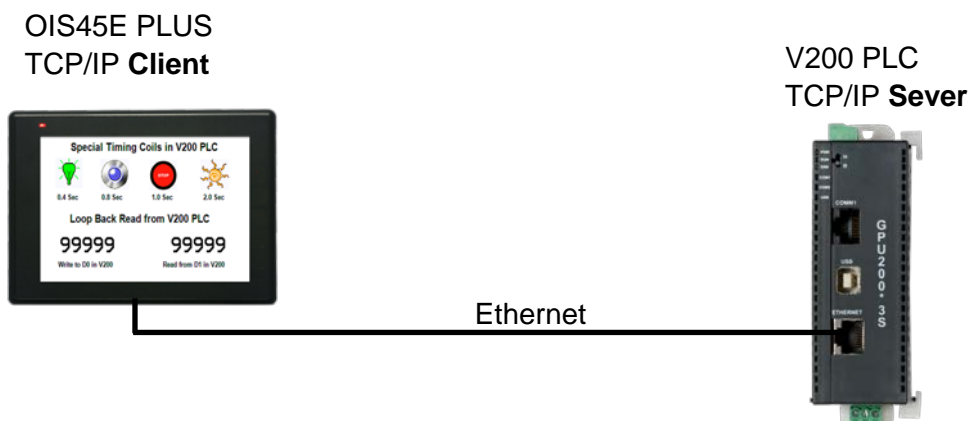

The following Ethernet capable devices, using the OIL-DS software, can be setup as either a Modbus TCP/IP client or a Modbus TCP/IP server:

OIS45E PLUS
OIS70E PLUS

OIS120A
V200 CPU 200

The following example will show how to setup a Modbus client and a Modbus server. For simplicity the example will only show setting up the V200 PLC as the Modbus server. However, setting up the other servers is very similar.

The example will be a proof of communications example. There are two parts to the example. In part 1, the OIS45E PLUS will be setup to monitor special timing ON/OFF bits in the V200 PLC.

Duty Cycle	V200 Address	OIS PLUS Modbus Address
0.4 Sec	M00482	035483
0.8 Sec	M00483	035484
1.0 Sec	M00484	035845
2.0 Sec	M00485	035846

The significance of the Modbus addresses will be explained when the server is setup.

In part 2 a simple loop-back test will be done. A number will be entered into D1 on the OIS40E PLUS. That number will be sent to the V200, moved from D0 (450001) to D1 (450002) in the V200, and read back in the OIS40E PLUS.

When this example is setup and executing properly, it proves:

- ◆ Cabling is correct.
- ◆ Protocols are set correctly
- ◆ Communication parameters match
- ◆ Modbus register/device mapping is correct.
- ◆ Both devices are operating correctly.

For a detailed understanding of Ethernet networking, it is recommend that both Modbus client and server examples be studied carefully before any setup/programming is started.

2.1 Modbus Client Setup

Open the OIL-DS software, click on New Project and select the OIS45E PLUS

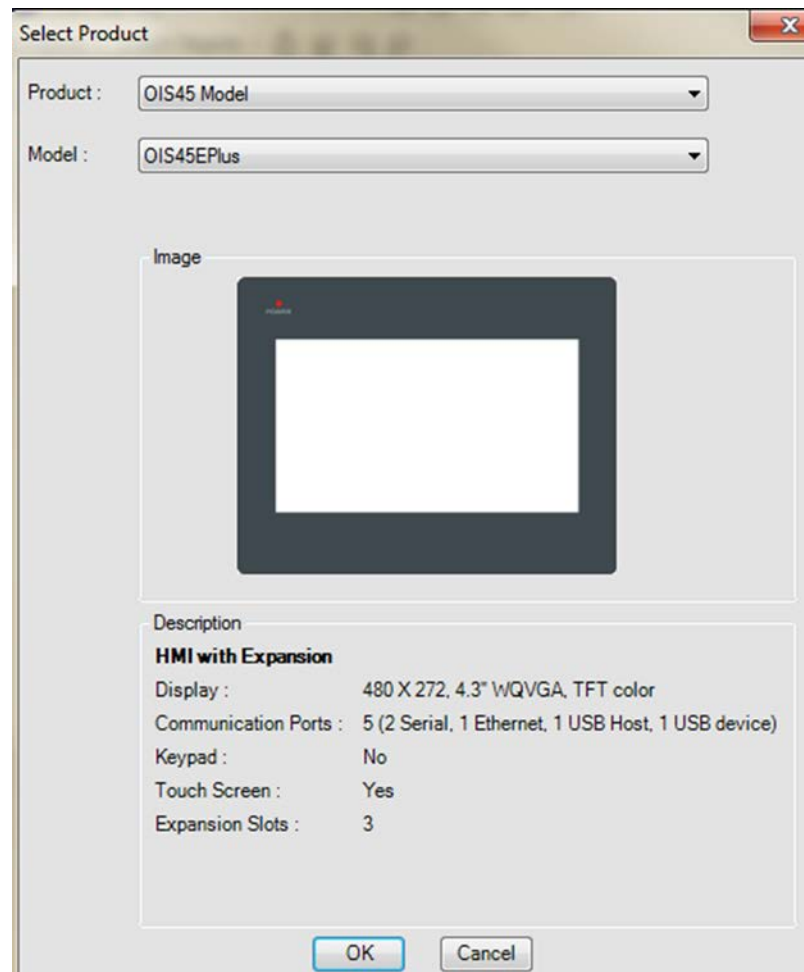

Make sure the E (for Ethernet) model is selected.

2.1.1 Define the OIS45E PLUS Network

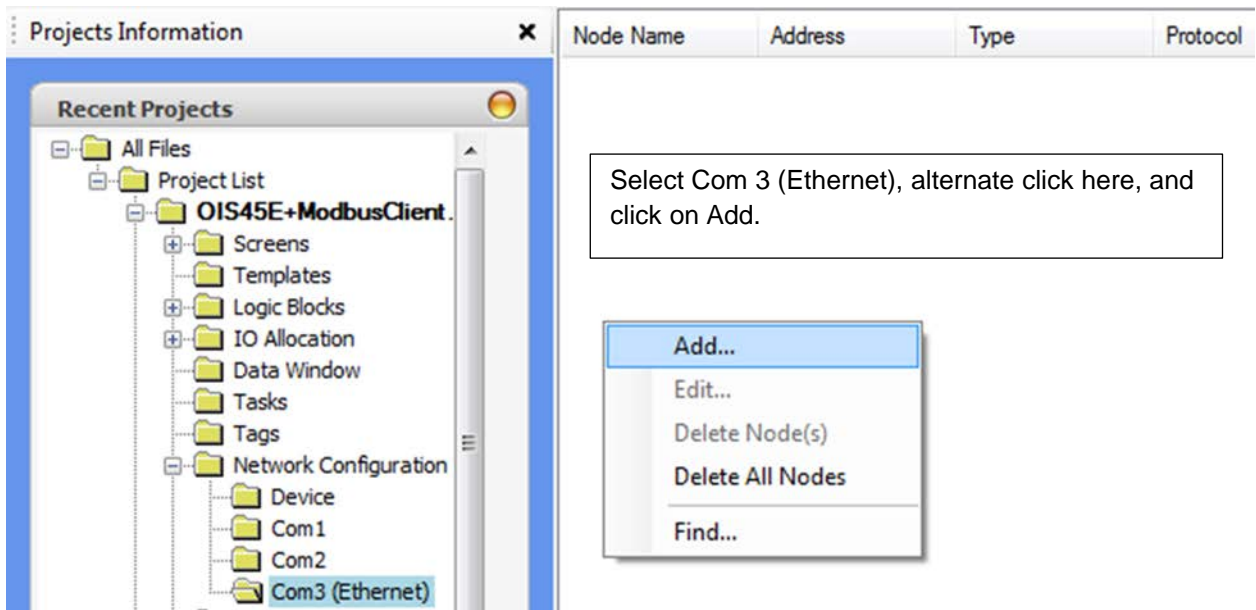

Setup Node 1 as shown:

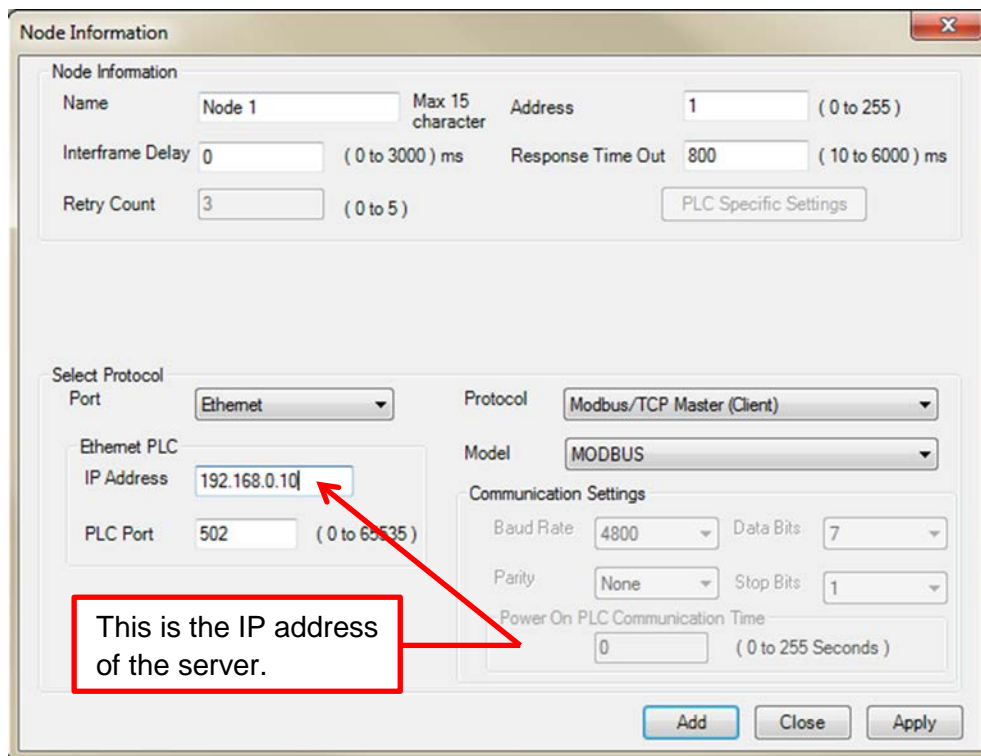

Node 1 is the V200 CPU. Note that its Ethernet address IP address, 192.168.0.10, is setup here. If additional servers are required, each should be setup as a separate Node with its own Ethernet IP address.

It is also necessary to assign an Ethernet IP address to the OIS45E PLUS. The OIS45E PLUS's address is set in the project configuration window. Under the Project Menu, select Properties. Then click on the Ethernet tab.

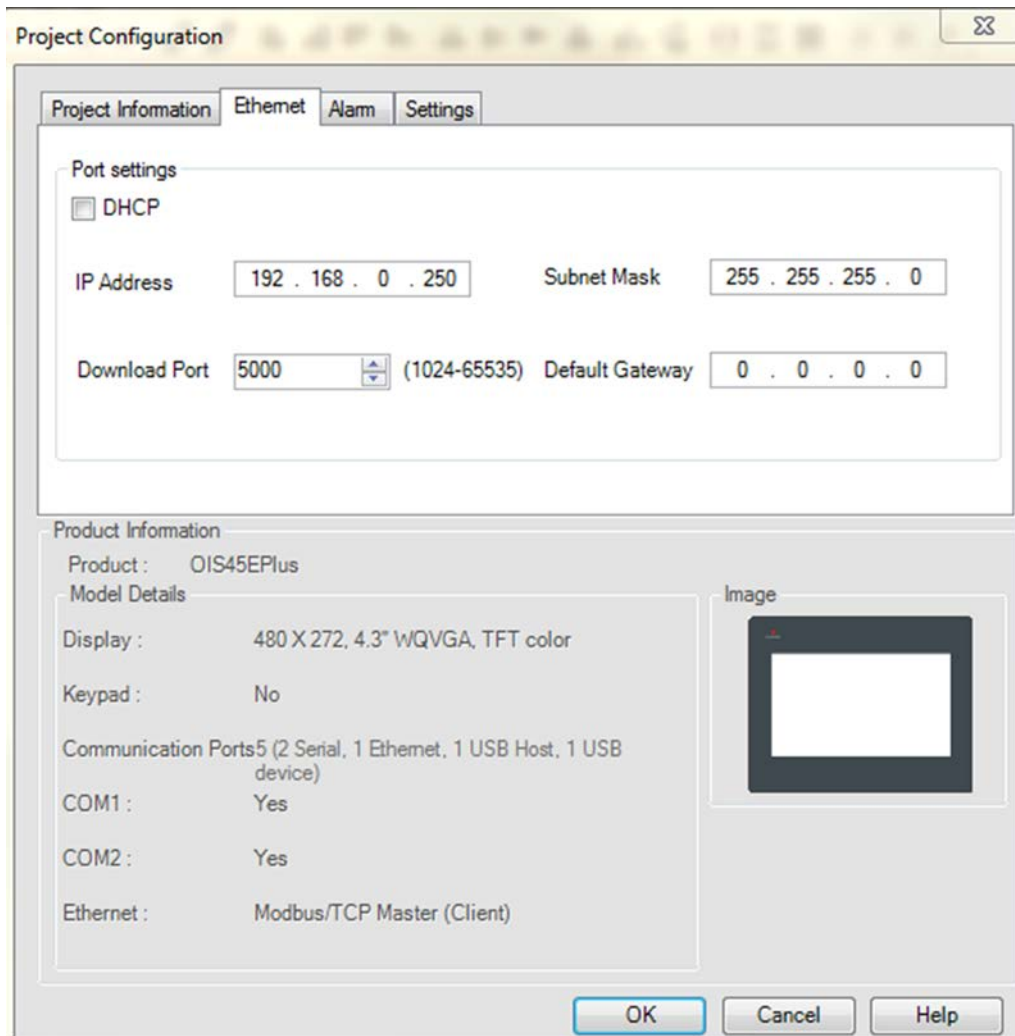

Set the IP Address as shown. Download port should be set at 5000. Accept the defaults for the Subnet Mask and the Default Gateway.

2.1.2 Enter OIS45E PLUS Tags

The next step is to assign Tags to the Modbus Client. In the Navigator Pane, click on Tags, the default tags assigned to the OIS45E PLUS are displayed as shown.

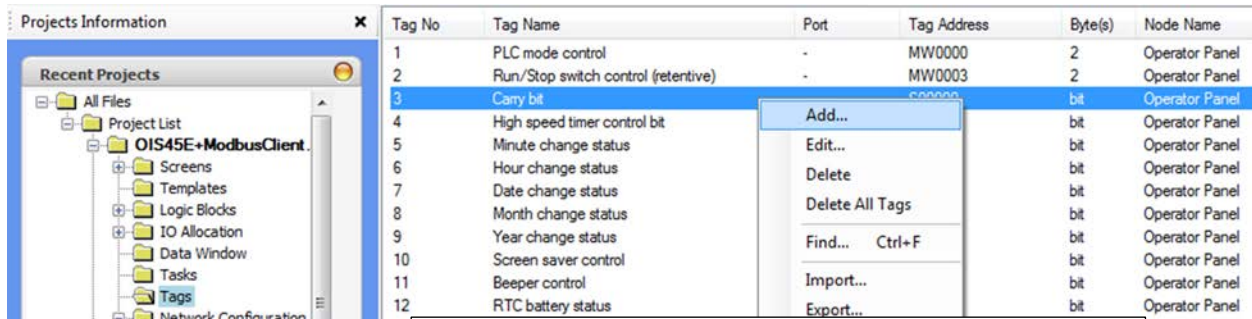

The screenshot shows a 'Projects Information' window with a tree view on the left and a table of tags on the right. The tree view shows a project named 'OIS45E+ModbusClient' with sub-items like 'Screens', 'Templates', 'Logic Blocks', 'IO Allocation', 'Data Window', 'Tasks', 'Tags', and 'Network Configuration'. The 'Tags' folder is selected. The table lists 12 tags with columns for Tag No, Tag Name, Port, Tag Address, Byte(s), and Node Name. A context menu is open over the third tag, 'Carry bit', with options: Add..., Edit..., Delete, Delete All Tags, Find... (Ctrl+F), Import..., and Export...

Tag No	Tag Name	Port	Tag Address	Byte(s)	Node Name
1	PLC mode control	-	MW0000	2	Operator Panel
2	Run/Stop switch control (retentive)	-	MW0003	2	Operator Panel
3	Carry bit	-	...	bit	Operator Panel
4	High speed timer control bit	-	...	bit	Operator Panel
5	Minute change status	-	...	bit	Operator Panel
6	Hour change status	-	...	bit	Operator Panel
7	Date change status	-	...	bit	Operator Panel
8	Month change status	-	...	bit	Operator Panel
9	Year change status	-	...	bit	Operator Panel
10	Screen saver control	-	...	bit	Operator Panel
11	Beeper control	-	...	bit	Operator Panel
12	RTC battery status	-	...	bit	Operator Panel

Alternate click in the tags window and click on Add.

Make sure Node name is Node 1 Modbus RTU (Unit as Master), then enter the Modbus coil 35483 as shown:

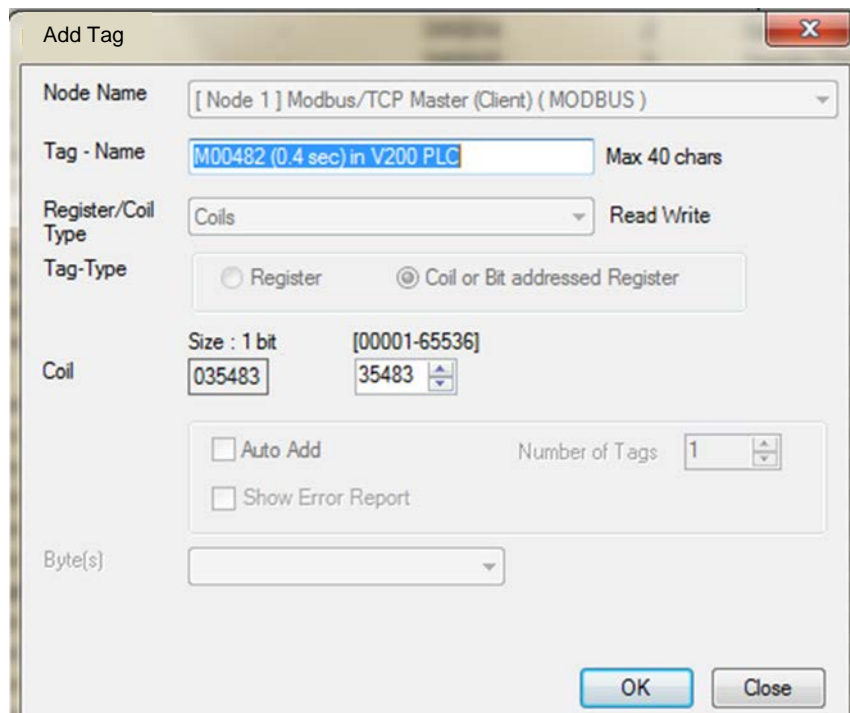

The 'Add Tag' dialog box is shown with the following fields and options:

- Node Name: [Node 1] Modbus/TCP Master (Client) (MODBUS)
- Tag - Name: M00482 (0.4 sec) in V200 PLC (Max 40 chars)
- Register/Coil Type: Coils (Read Write)
- Tag-Type: Register Coil or Bit addressed Register
- Coil: Size : 1 bit [00001-65536]
035483 35483
- Auto Add: (Number of Tags: 1)
- Show Error Report:
- Byte(s): []

Buttons: OK, Close

Keep adding tags until all 6 of the tags shown below are added to Com1, Node 1:

M00482 (0.4 sec) in V200 PLC	Ethernet	035483	bit	Node 1	User Defined Tag
M00483 (0.8 sec) in V200 PLC	Ethernet	035484	bit	Node 1	User Defined Tag
M00484 (1.0 sec) in V200 PLC	Ethernet	035485	bit	Node 1	User Defined Tag
M00485 (2.0 sec) in V200 PLC	Ethernet	035486	bit	Node 1	User Defined Tag
D0000 in V200 PLC	Ethernet	450001	2	Node 1	User Defined Tag
D0001 in V200 PLC	Ethernet	450002	2	Node 1	User Defined Tag

Note: Additional tags can be added at any time later on.

2.1.3 Create the OIS45E PLUS Screens

Screens can now be created. In this example only one screen will be used. Create screen 1 as shown:

Special Timing Coils in V200 PLC



Loop Back Read from V200 PLC

999999

Write to D0 in V200

999999

Read from D1 in V200

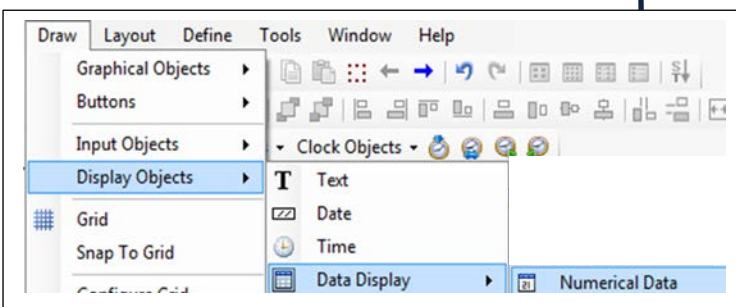
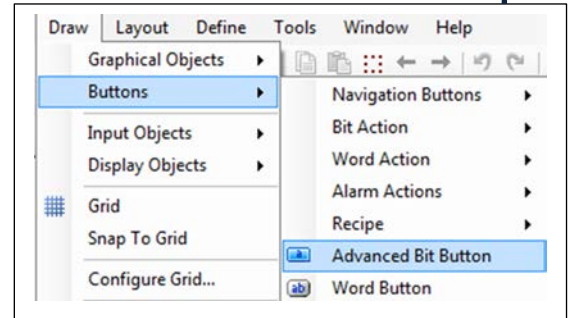
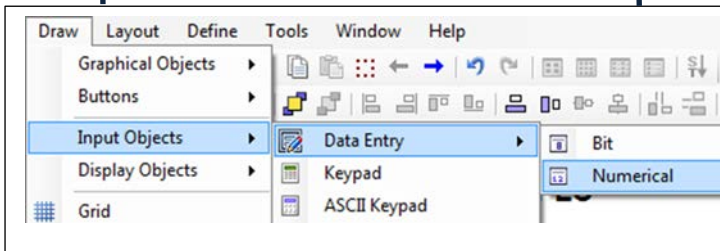

Now the tags can be attached to the screen objects. Often times it is easier to attach the tags to the objects as the objects are created. It can be done either way.

Select a button object.

Assign properties using the properties pane.

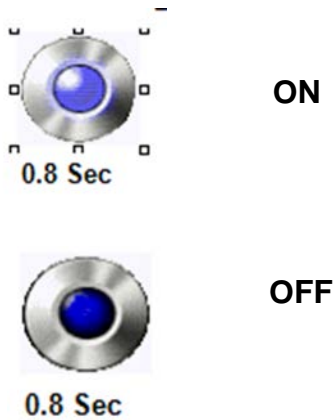

First select Feedback Tag. Then it is possible to select the ON image and the OFF image..

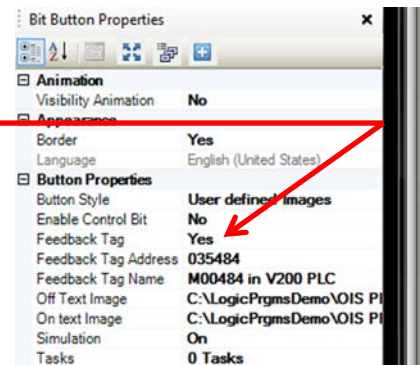

Select the input object.



Pressing the data entry 99999 will cause the data entry keypad to appear. Key in a number and press enter

This keypad will appear when the area 9999 is pressed.

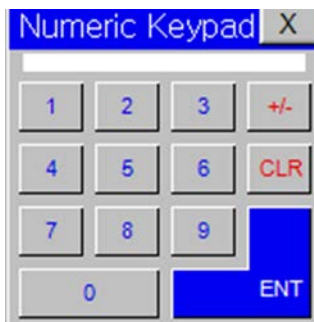

Make sure screen name "Numeric Keypad" is selected.

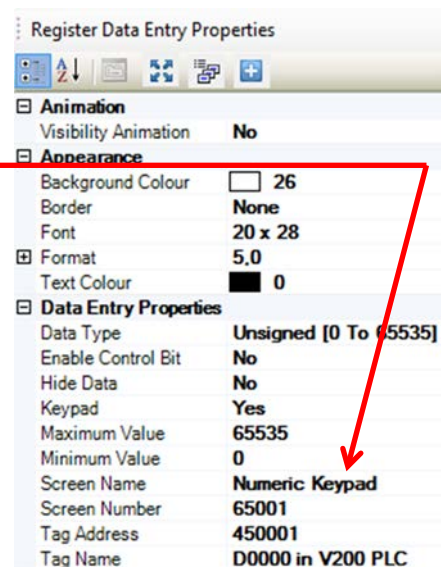

Select a data object to display.



Be sure to select the Modbus tag that is mapped to D0001 in the V200 PLC

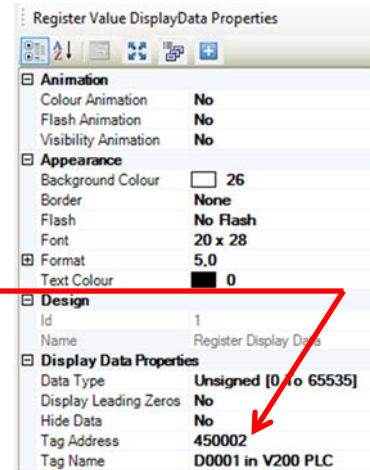

If desired, the beeper can be turned OFF for screen 1. Select the task under screen 1 and set it up as follows:

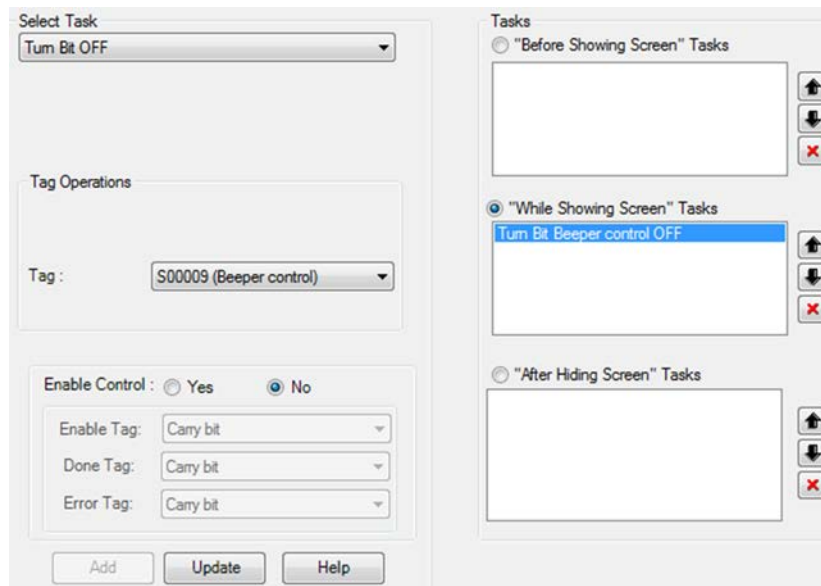

This completes setup of the Modbus TCP client.

2.2 Modbus Server Setup

Open the OIL-DS software if it is not already open, click on New Project and select the V200 PLC. Select the GPU200 model.

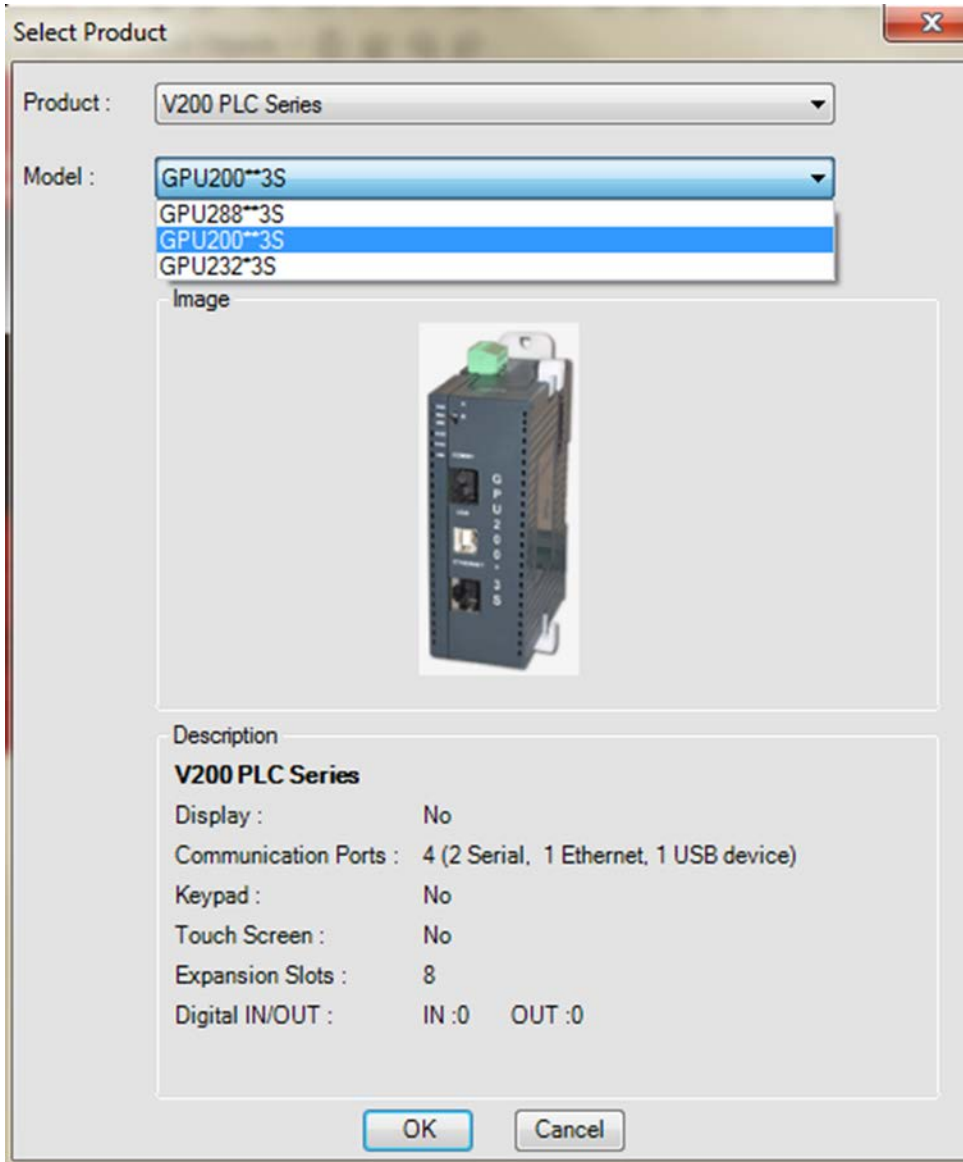

2.2.1 Define the V200 Network

Go to the navigation pane and define the network.

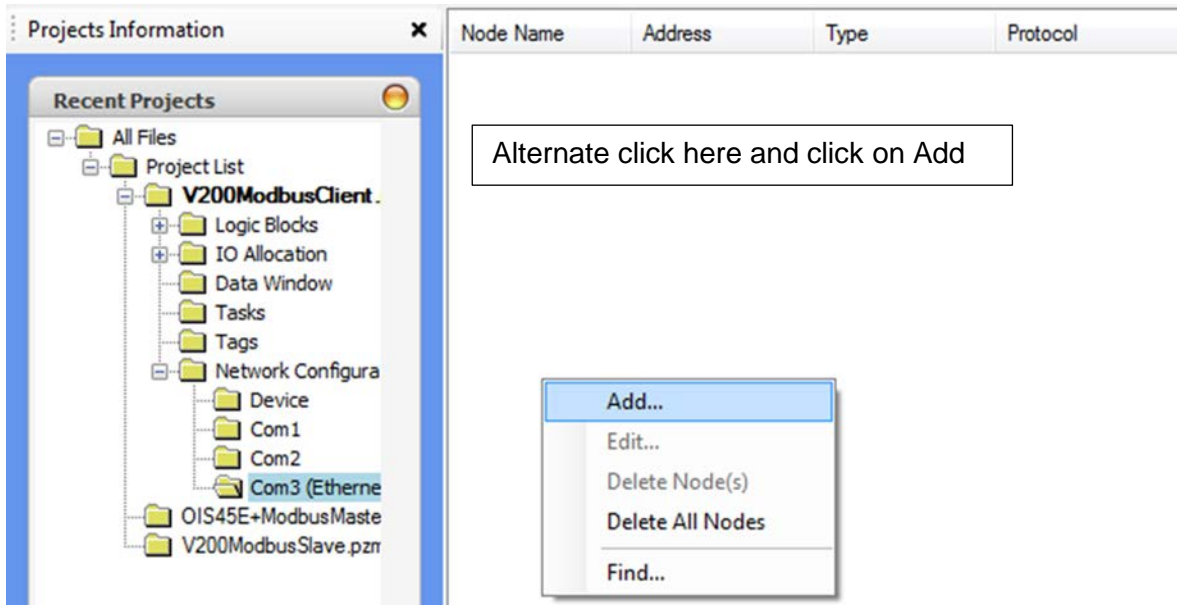

When the Node information screen appears, select Modbus TCP Server (Slave) for protocol. After this selection is made, no other choices are available in this setup box.

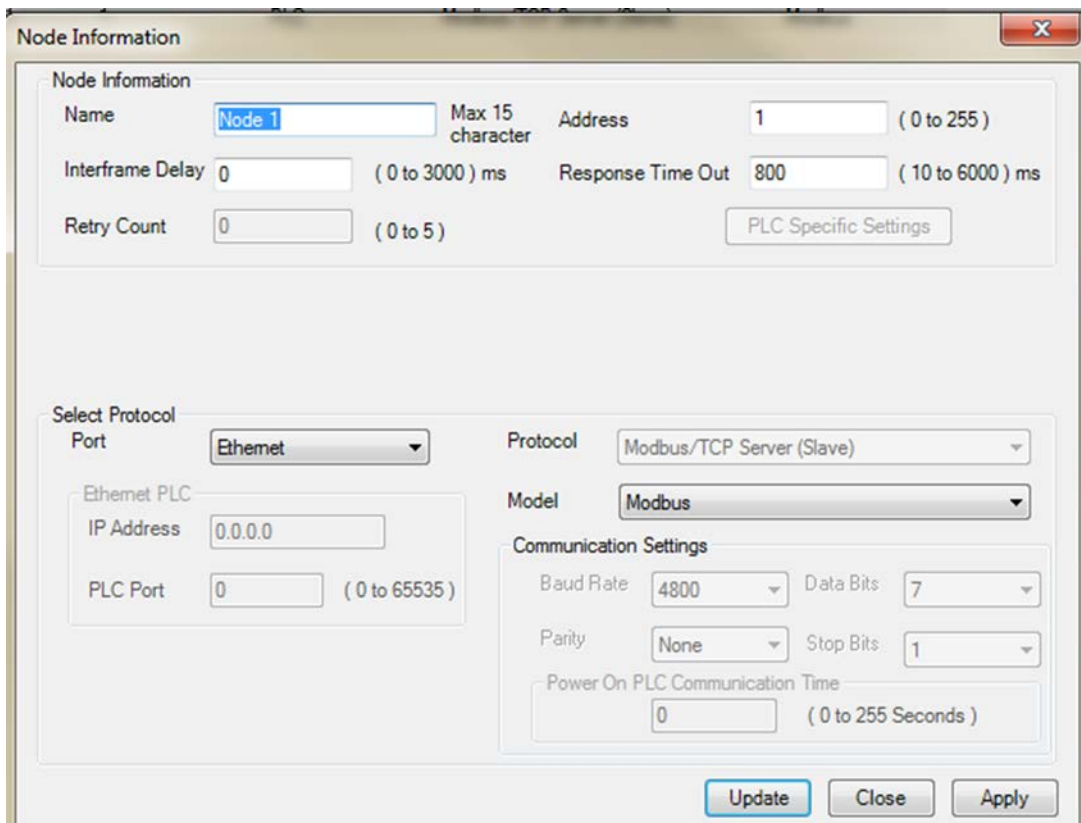

Now it is necessary to assign an IP address for the V200. Under the Project menu, select Properties. Then click on the Ethernet tab. Set the V200's IP address as shown: Leave everything else at the default settings.

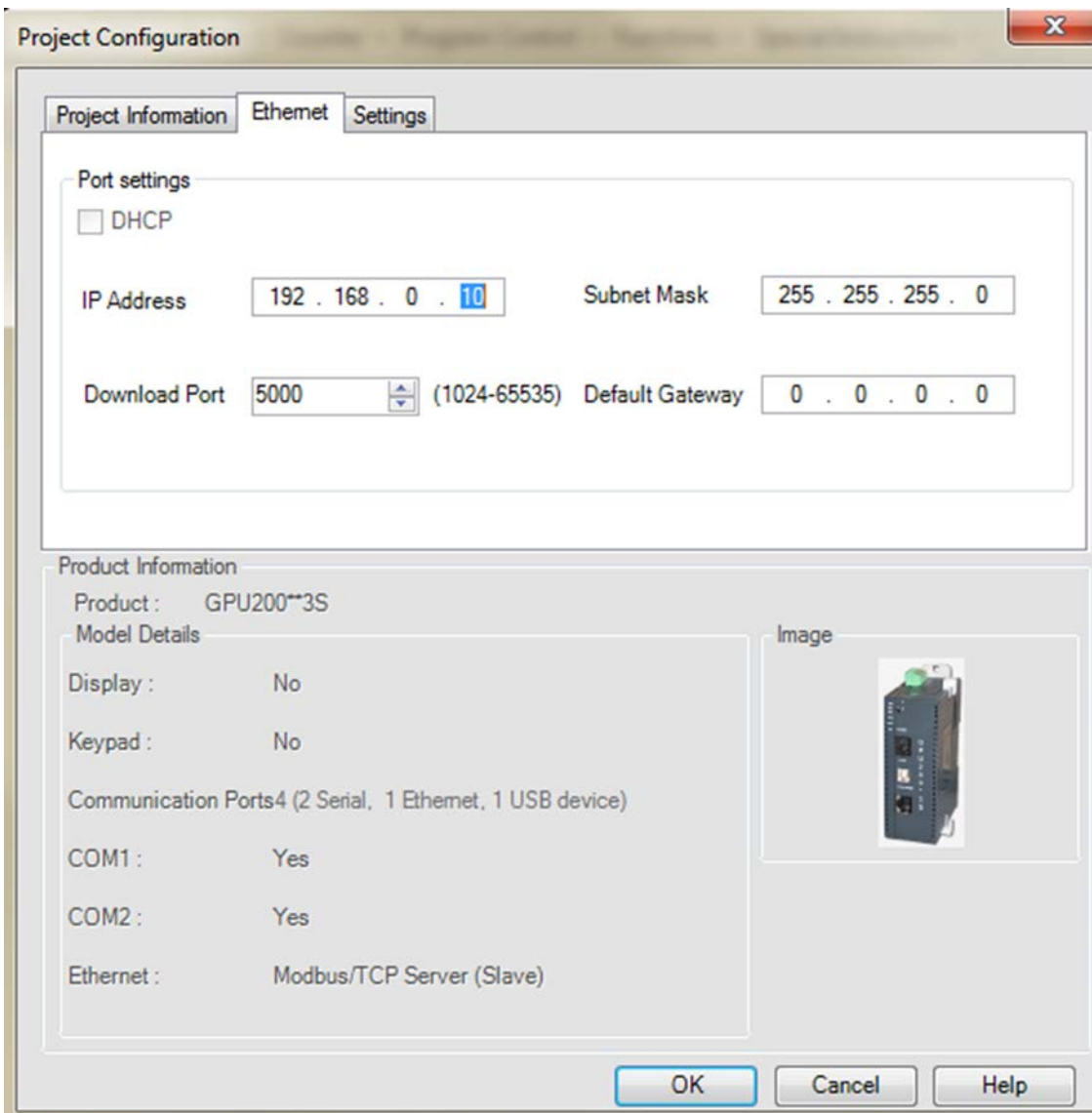

The V200 PLC is now setup as the Modbus TCP/IP server. If additional V200 PLCs are required as servers, they would be setup exactly as above except they would have a different IP address; 192 . 168 . 0 . 20 for example.

2.2.2 Enter V200 Tags

The next step is to assign Tags to the Modbus Server. In the Navigator Pane, click on Tags, the default tags assigned to the V200 are displayed as shown. Click on Add.

Tag No	Tag Name	Port	Tag Address	Byte(s)	Node Name
11	System timer coil for 0.1 sec interval	-	M00480	bit	Operator Panel
12	System timer coil for 0.2 sec interval	-	M00481	bit	Operator Panel
13	System timer coil for 0.4 sec interval	-	M00482	bit	Operator Panel
14	System timer coil for 0.8 sec interval	-	M00483	bit	Operator Panel
15	System timer coil for 1 sec interval	-	M00484	bit	Operator Panel
16	System timer coil for 2 sec interval	-	M00485	bit	Operator Panel
17	System timer coil for 4 sec interval	-	M00486	bit	Operator Panel
18	System timer coil for 8 sec interval	-	M00487	bit	Operator Panel
19	Timer interrupt ladder execution status	-	M00496	bit	Operator Panel
20		-	M00497	bit	Operator Panel
21		-	M00498	bit	Operator Panel
22		-	M00512	bit	Operator Panel
23		-	M00513	bit	Operator Panel
24		-	MW0000	2	Operator Panel
25		-	MW0003	2	Operator Panel

Note that special timing bits M00480 – M00487 are already defined as default tags. Nothing more has to be done with these tags. But D0 and D1 must be defined.

Add Tag

Node Name: [Operator Panel] None (-)

Tag - Name: Data from OIS45E PLUS 450001 (Max 40 chars)

Register/Coil Type: Data Registers (Read Write)

Tag-Type: Register Coil or Bit addressed Register

Register: D00000 (Size: 2 bytes, Range: [00000-04095], Value: 0)

Auto Add (Number of Tags: 1) Show Error Report

Byte(s): 2-Bytes(1-word)

Add Close

When complete the tag list should look as follows:

Tag No	Tag Name	Port	Tag Address	Byte(s)	Node Name	Tag Type
49	Data from OIS45E PLUS 450002	-	D00001	2	Operator Panel	UserDefined Tag
48	Data from OIS45E PLUS 450001	-	D00000	2	Operator Panel	UserDefined Tag

Note: Additional tags can be added at any time later on.

By this point a question should have arisen: How are the OIS45E PLUS and V200 registers mapped to Modbus registers? The answer is: It happens automatically when the Ethernet com port is assigned as a Modbus TCP/IP server. For the V200 the mapping is as follows:

Modbus Slave Mapping: OIS45E PLUS thru OIS120A & V200 PLCs.

Sr.No.	Register / Coil	Abv.	Tag Length	Range	Modbus Mapping
1	Timer Register (R/W)	T	2 Bytes	0000-0255	400001 - 400256
2	Counter Register (R/W)	C	2 Bytes	0000-0255	410001 - 410256
3	System Register (R/W)	SW	2 Bytes	0000-0255	420001 - 420256
4	Retentive Register (R/W)	R	2 Bytes	0000-1399	430001 - 431400
5	Input Register (R)	XW	2 Bytes	0000-0399	440001 - 440400
6	Output Register (R/W)	YW	2 Bytes	0000-0399	441001 - 441400
7	Internal Register (R/W)	BW	2 Bytes	0000-0255	442001 - 442256
8	Index Registers	I/J/K	2 Bytes	0000-0002	443001- 443003
9	Configuration Register	MW	2 Bytes	0000-1599	460001-461600
10	Data Register (R/W)	D	2 Bytes	0000-4095	450001 - 454096
11	Input Coil (R)	X	1 Bit	0000-6399	000001 - 006400
12	Output Coil (R/W)	Y	1 Bit	0000-6399	010001 - 016400
13	System Coil (R/W)	S	1 Bit	0000-0099	020001 - 020100
14	Internal Coil (R/W)	B	1 Bit	0000-4095	030001 - 034096
15	Timer Coil(R/W)	T.xxxx	1 Bit	0000-0255	021001-021256
16	Counter Coil(R/W)	C.xxxx	1 Bit	0000-0255	022001-022256
17	Configuration Coil(R/W)	M	1 Bit	00000-25599	035001- 060600

Notes:

1. Modbus register/coil tag length is the same as V200 register/coil tag length.
2. Each manufacturer has an equivalent table for their industrial devices when they are designated a Modbus server in a Modbus Ethernet network. Without knowing the mapping between the server devices internal registers/bits to the Modbus registers/bits, a Modbus network can not be established.

Modbus Slave Mapping: I/O Register Examples

Example 1: GPU200 No I/O GDI216 16in GDD288 8in/8out

	Inputs	Outputs
CPU Slot		
Slot 1	XW0100=440002	
Slot 2	XW0200=440003	YW0200=441002

Example 2: GPU200 No I/O GAD208 8 AI GDD288 8in/8out

	Inputs	Outputs
CPU Slot		
Slot 1	XW0100=440002 XW0101=440003 to XW0107=440009	
Slot 2	XW0200=440010	YW0200=441002

Example 3: GPU200 No I/O GAA242 4 AI/2 AO GDD288 8in/8out

	Inputs	Outputs
CPU Slot		
Slot 1	XW0100=440002 XW0101=440003 to XW0103=440005	YW0100=441002 YW0101=441003
Slot 2	XW0200=440006	YW0200=441004

Example 4: OIS PLUS TRPAIO0202L 2 AI/2 AO TRPOIO0808P 8 DI/8 DO

	Inputs	Outputs
OIS PLUS		
Slot 1	XW0100=440001	YW0100=441001
	XW0101=440002	YW0101=441002
Slot 2	XW0200=440003	YW0200=441003

Note: If a program was written and then one module is changed to a different type, all of the Modbus addressing to the right of the changed module will change

2.2.3 Program Ladder Logic in the V200

In order for the OIS45E PLUS data entered in D0 to loop back in D1, a MOV (move) instruction must be programmed in the V200. Open the ladder logic programming screen in the V200 PLC. Selecting Main Block 1 opens the programming pane.

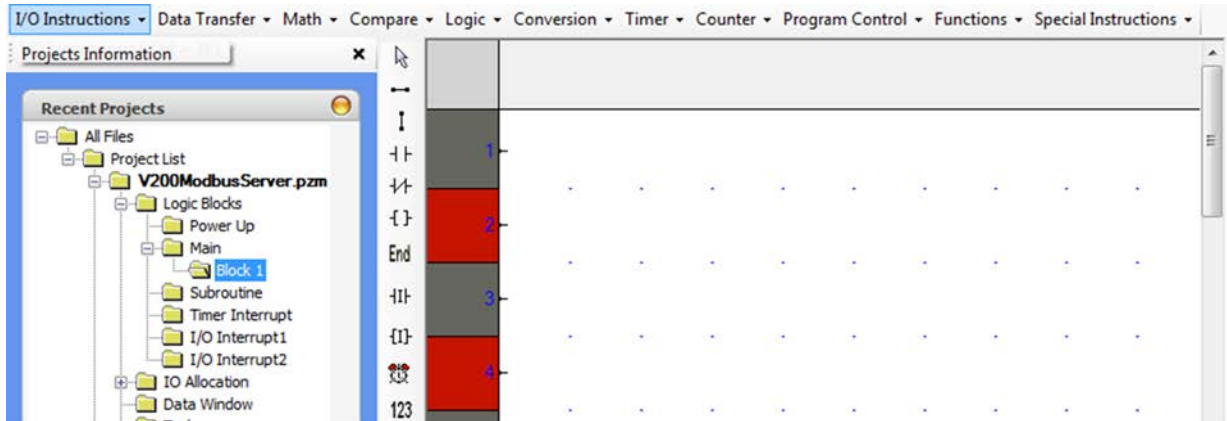

Create the following program. Go to Data Transfer and select the MOV instruction. Then add the END instruction

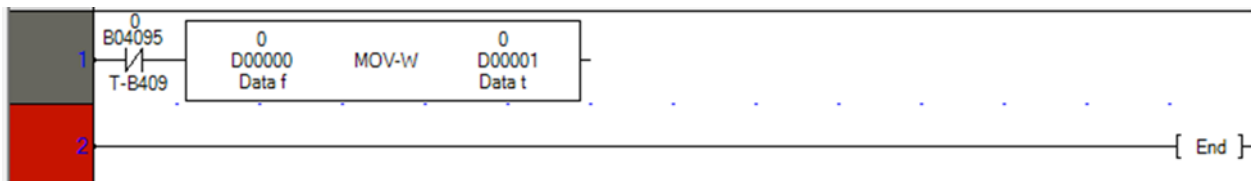

This completes setup of the V200 as a Modbus RTU slave.

The programs created for the OIS45E PLUS and the V200 PLC can be loaded into each device respectively. Please see Section 3, Physical Connections for cabling information. When everything is complete, it will then be possible to observe Modbus network communication between the Modbus client and the Modbus server.

Again, it will confirm the following:

- ◆ Cabling is correct.
- ◆ Protocols are set correctly
- ◆ Communication parameters match
- ◆ Modbus register/device mapping is correct.
- ◆ Both devices are operating correctly.

2.2.4 Ladder Logic Programming with Modbus Tags

At this time it is not possible to use Modbus registers/devices directly in the ladder program. For example, in the OIS45E PLUS if it is necessary to multiply the value in Modbus register 450002 (D1 in the V200 PLC) by 10, 450002 cannot be used in the ladder logic program. **The following is not possible:**



Instead, the value in 450002 must be copied into one of the OIS45E PLUS's registers. This is done using a global task. Select Tasks from the navigation pane.

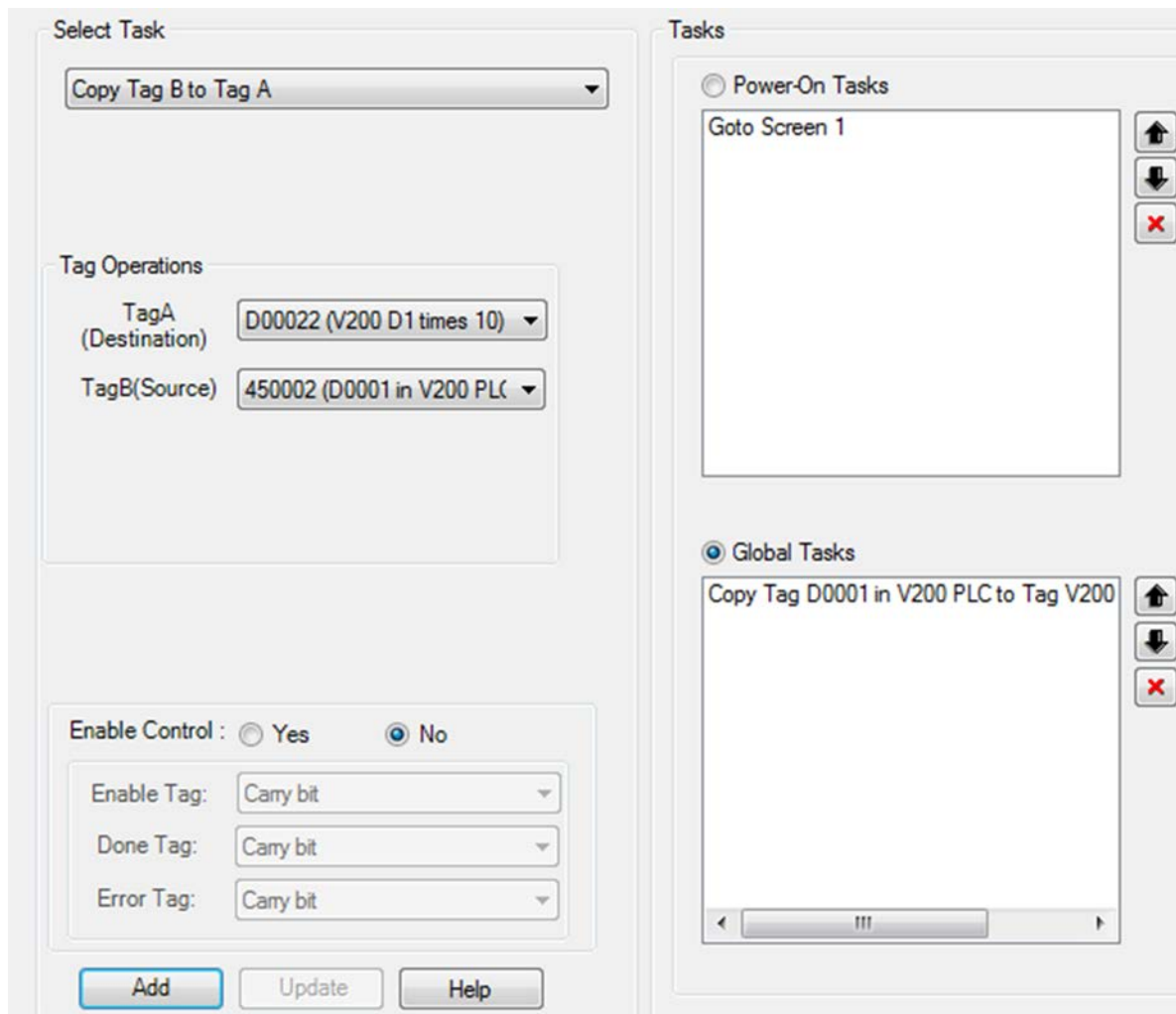

Now D22 can be used as an operand in the multiplication function block above. If a lot of registers from the V200 PLC need to be used in the OIS45E PLUS ladder program, Block Copy is available. A block of up to 999 continuous registers can be transferred with one Block Copy global task.

Physical Connections

- ◆ Modbus Serial Connections
- ◆ Modbus TCP/IP Ethernet Connections

3.1 Modbus Serial Connections

There are 3 possible serial connections between the OIS45E PLUS and the V200 PLC. The connector on the OIS45E PLUS (and all the OIS PLUS displays) is the same, a 9 pin D-shell. However, the wires in the D-shell are connected differently for each type of connection. The three connections methods from the OIS45E PLUS are:

Type	Port On V200	Cable
RS232, 2 wire	Com1	RC-O-009H-00
RS485, 4 wire	Com1	RC-O-009I-00
RS485, 2 wire	Com2	RC-O-009J-00

RC-O-009H-00 Diagram

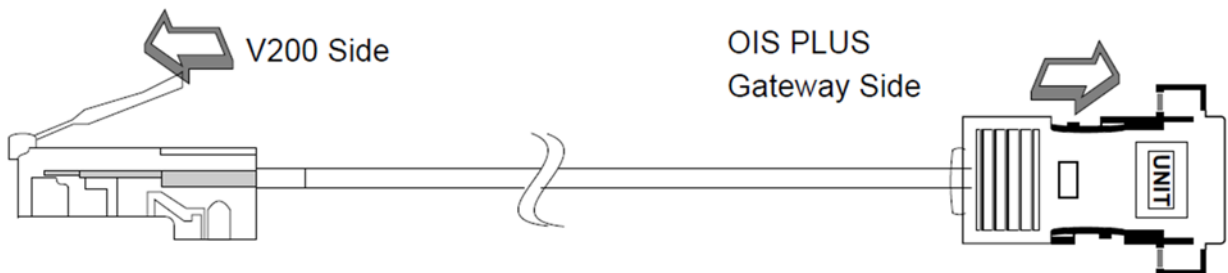
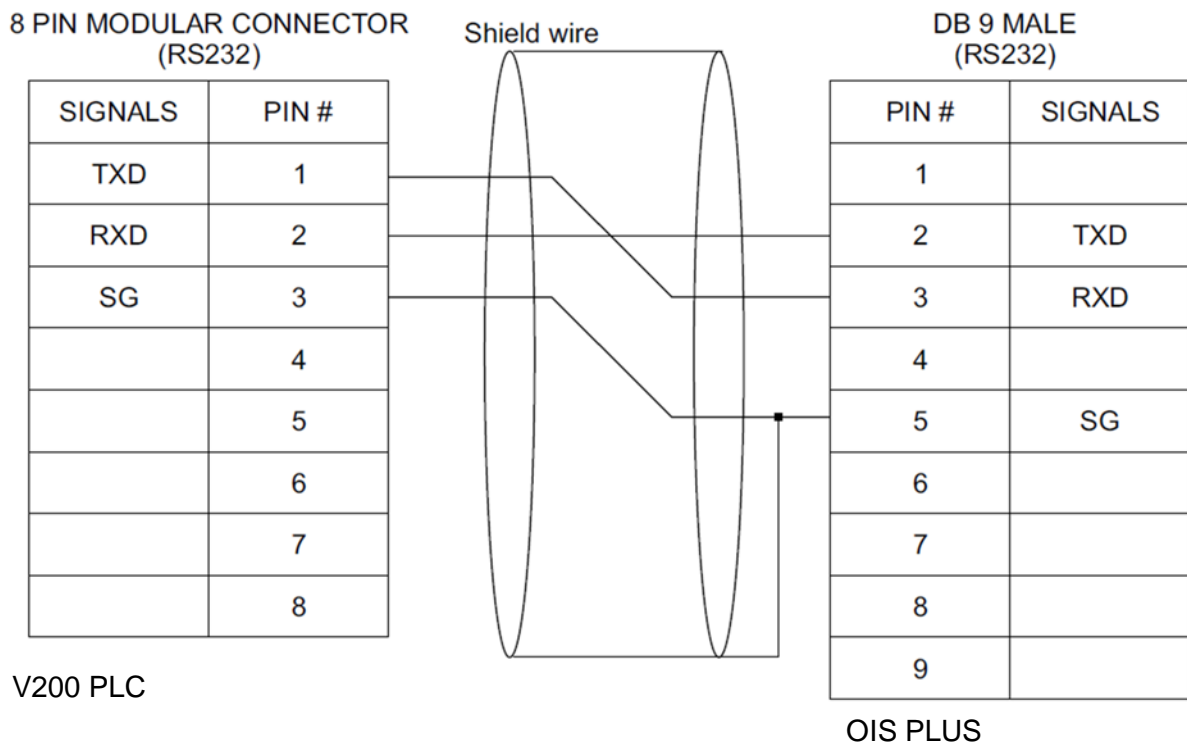

Only connect wires shown, do not connect any other wires.

RC-O-009I-00 Diagram

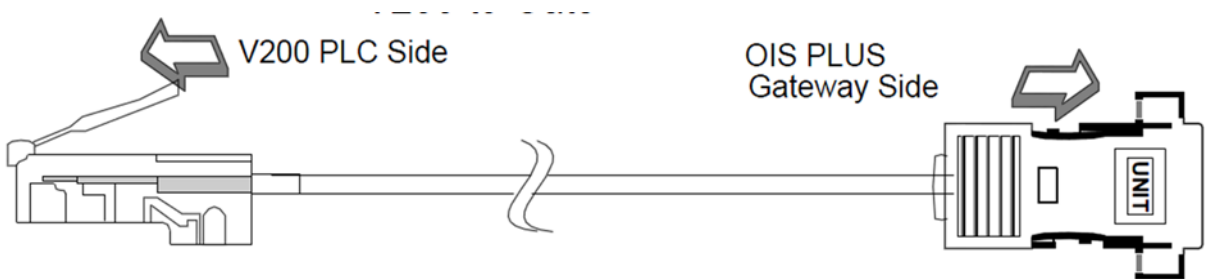
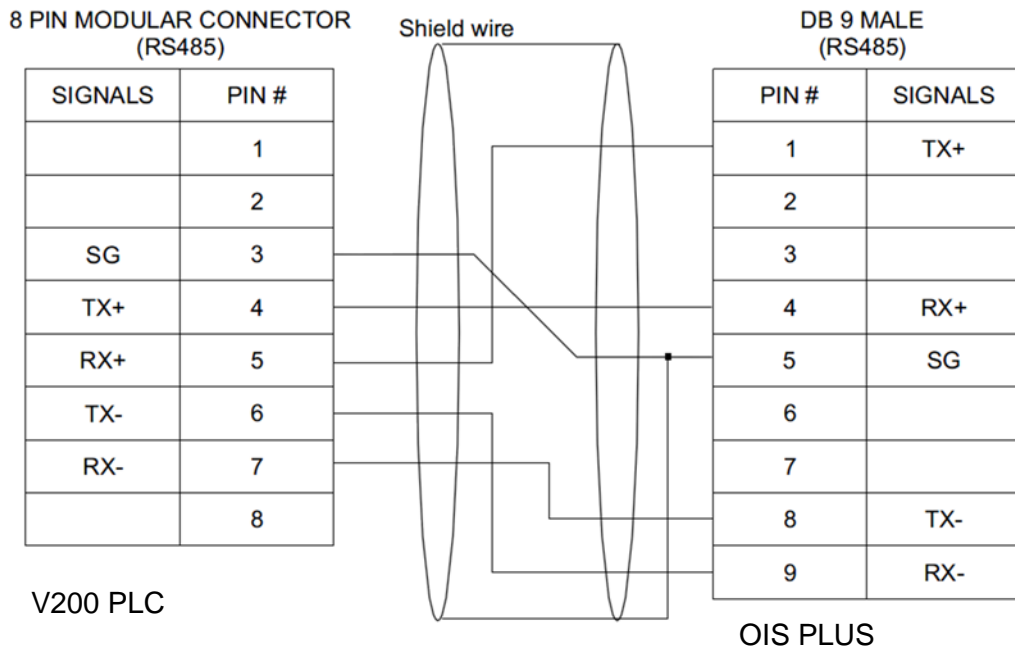

Only connect wires shown, do not connect any other wires.

RC-O-009J-00 Diagram

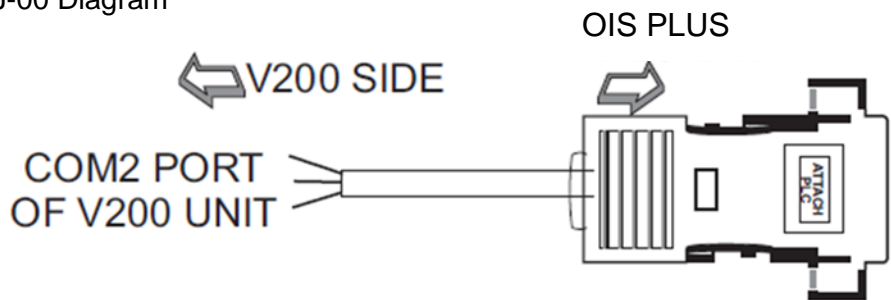

COM2 PORT	PIN SIGNAL	DB9M PIN NO.
A	TX+ & RX+	4 & 1
B	TX- & RX-	9 & 8
Gnd	Gnd	5

Shield connect only 5 no pin at DB9

When connecting multiple V200 PLCs together using their Com1 ports, an RJ45 to screw terminal adapter is often quite useful.

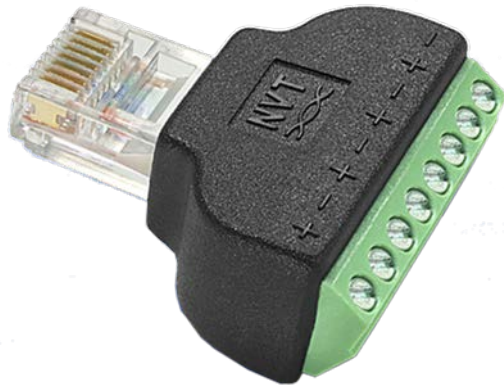

The above device, part number NV-RJ45A, is from:

Network Video Technologies

4005 Bohannon Drive • Menlo Park, CA
94025 • USA
(+1) 650.462.8100 • 800.959.9870 • FAX
(+1) 650.326.1940
www.nvt.com • info@nvt.com

3.2 Modbus Ethernet Connections

There are two types of Ethernet cables used:

- Cross cable
- Straight thru cable.

A cross cable is used for a direct connection between a computer and the Ethernet port on an OIS PLUS or V200 PLC. It is also used when the Ethernet port on the OIS PLUS is connected directly to the Ethernet port on the V200 PLC.

A straight thru cable is used for connecting the OIS PLUS or V200's Ethernet port to an Ethernet switch.

Be sure to use the correct cable depending on the connection.

Note: The OIS PLUS and V200 PLCs support automatic crossover detection. This allows these devices to configure their Ethernet port for correct operation according to the cable connected. So even if the correct cable is not selected, the connection may still work.

TOSHIBA INDUSTRIAL PRODUCTS:

- Adjustable Speed Drives
- Motors
- Motor Controls
- PLCs, DCS, & Instrumentation
- Uninterruptible Power Systems

Toshiba International Corporation
Industrial Division •
13131 West Little York Road
Houston, Texas 77041 USA •
Tel +713-466-0277 US 1-800-231-1412 •

TOSHIBA
Leading Innovation >>>

www.toshiba.com/ind
plc@tic.toshiba.com