



HARBIN ROPV INDUSTRY DEVELOPMENT CENTER

ROPV R40 E Series User Manual

For Use with the Following ROPV Pressure Vessel Models:

R40 600E

R40 800E

R40 1000E

R40 1200E

Headquarters

Harbin ROPV Industry Development Center

100 Hongqi St.

Xiangfang District

Harbin, China 150036

Tel: +86-451-5515-5144

Fax: +86-451-5515-5124

Email: ropv@ropv.com.cn

Website: www.ropv.com.cn

General Product Description – R40 E Series End Port Membrane Housing

R40 600E Design Pressure: 600PSI / 4.1Mpa / 41Bar (at 120°F / 49°C)
R40 800E Design Pressure: 800PSI / 5.6Mpa / 56Bar (at 120°F / 49°C)
R40 1000E Design Pressure: 1000PSI / 6.9Mpa / 69Bar (at 120°F / 49°C)
R40 1200E Design Pressure: 1000PSI / 6.9Mpa / 69Bar (at 120°F / 49°C)

Min. Operating Temp.: 20°F / -6°C
Max. Operating Temp.: 120°F / 49°C
Factory Test Pressure: ASME: 1.1x Design Pressure
Standard: 1.5x Design Pressure
Burst Pressure: 6X Design Pressure
Operating pH Range: 3 – 11
Cleaning pH Range: 2 – 12 (less than 30 minutes)

General Warning – High Pressure Membrane Housing

ROPV vessels are designed to provide safe operation over a long service life if properly installed, operated, and maintained. The vessel may cause loss of life, severe bodily harm, or property damage if not correctly installed, operated, or maintained. Read and understand all guidelines provided in the vessel User Guide. Observe every precaution contained therein. Failure to do so may result in malfunction and potential catastrophic failure. Qualified technicians experienced in servicing hydraulic systems should be used to work with this vessel. Misuse, incorrect assembly, or use of damaged/corroded components may result in catastrophic failure.

Vessel Use and Precautions

- Positive pressure up to the design pressure (PSI) of the specific model being used.
- The required vessel/element interface hardware is supplied with the vessel (not required for all models). Ensure that an element adapter is installed at each end of the vessel before use.
- Vessel expands under pressure and careful consideration must be taken when installing straps/saddles and system connection piping.
- Installation with the straps/saddles provided is strongly recommended.
- Vessel should not support any other system components. Connections should be non-load bearing.
- Periodic inspection of the vessel end closure is recommended to ensure all parts are dry and free of corrosion.
- Failure to understand and follow all precautions may void warranty and result in catastrophic failure of the vessel.
- These guidelines are subject to change. Please check with ROPV to ensure that the User Manual is the latest version for the vessel model being used.
- Mount vessel using strap/saddle hardware provided and span recommended in the engineering drawing.

- Do not over tighten the straps – vessel must be allowed to expand under operation.
- Maximize the connection flexibility to allow for vessel growth under pressure.
- Align the end ports with the system manifold, correcting any misalignment before final installation.
- Provide overpressure protection in the system safety devices.
- Inspect end closures regularly for signs of corrosion. Immediate corrective action and/or replacement is suggested in case of corrosion.
- Relieve system pressure before working on the vessel.
- Do not attempt to over-tighten the Permeate Port connections as this may damage the end closure. One turn past hand tight should be sufficient.
- Never operate the vessel in excess of its ratings. This may void the warranty and cause bodily or property damage.
- Do not operate the vessel permeate port over 125PSI.
- Flush the vessel with permeate before system shutdown to reduce the chance of corrosion.
- Do not install the vessel in direct sunlight.
- Operate the vessel within the recommended pH range - Operating pH Range: 3 – 11, Cleaning pH Range: 2 – 12 (less than 30 minutes).

End Plug Removal

Step 1 Shut Down System and Relieve System Pressure – The system must be shut down and all pressure relieved before conducting any maintenance or repair on the vessel.

Step 2 Disconnect Permeate Piping – The system piping must be carefully removed from the vessel connections.

Step 3 Inspect End Closure – The end closure should be inspected for any signs of corrosion or damage. Surface corrosion can be removed with a wire brush, while flushing with water. Damaged components should be replaced with approved components from ROPV.

Step 4 Disconnect Locking Screws – Each of the three locking segments is held in place with one locking screw. The locking screws can be unthreaded using a hex wrench. The locking screws should be unthreaded from the locking segment. The locking screw and locking segment can be removed together.



Step 5 Remove the End Plug – A male threaded nipple is recommended for use when opening the end plug. Thread the pipe nipple into the permeate port of the end plug, gently motion the nipple in various directions, and then gently pull the nipple from the vessel. A firm tug may be required to release the end plug o-ring seal.

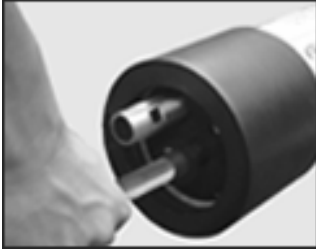

Complete End Plug



Head Disassembly and Inspection

Step 1 Remove the Head O-ring – Use a non-metallic, rounded tool to start the o-ring out of the o-ring groove. Once a small portion of the o-ring has been lifted out of the groove, use your hand to work the remainder of the o-ring out of the groove. Damaged or cut o-rings must be replaced during re-installation of the head.

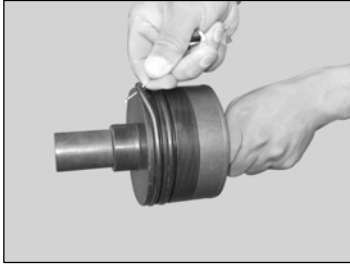

Step 2 Remove Adapter – Grasp the adapter and slowly pull from the bearing permeate port. A slight rotating motion may ease the removal of the adapter. There is a set of double o-rings on the inside diameter of the permeate port that must be inspected for damage once the adapter is removed. Damaged o-rings must be replaced before re-installation.



Step 3 Remove Bearing Plate – The bearing plate and sealing plate are connected by two interlinking screws. Unthread these screws with a hex wrench.



Step 4 Remove the Feed/Concentrate Port – Remove the two pieces of feed / concentrate port fixture. Grasping the sealing plate, rock the feed/concentrate port slightly and pull away from sealing plate. It may be necessary to tap the permeate port on the smaller end with a rubber mallet to release the seal bond.



Step 5 Remove the Permeate Port – Grasping the sealing plate, rock the permeate port slightly and pull away from sealing plate. It may be necessary to tap the permeate port on the smaller end with a rubber mallet to release the seal bond. Once it is removed, check the sealing plate o-ring seated between the permeate port and the sealing plate. Inspect for damage or foreign matter. Replacement o-rings are recommended during all head rebuilds.



Step 6 Clean All Components – All components should be cleaned with a mild soap solution or clean water. The components should be air dried or dried with a lint-free towel.

Step 7 Inspect All Components – All components should be carefully inspected for signs of corrosion and damage. Components exhibiting such should be replaced before re-installation. All o-rings should be carefully inspected for signs of damage. It is recommended that all o-rings be replaced during each complete servicing of the vessel. Failure to do so may cause poor system performance.

Step 8 Inspect Inside Vessel Surface – The inside surface of the vessel should also be inspected once the membrane elements have been removed. Special attention should be paid to identify any scratches, damage or foreign matter. Surface scratches can be repaired by carefully sanding the effected surface with 600-grit sandpaper. A combination of soapy water and fresh water should be used to flush the area during sanding. Clean water should be used to clean the area after sanding. Any extemporaneous matter can be removed with a soft cloth, soapy water, and a clean water flush. Damaged vessels should not be used under any circumstances.

Picture of Disassembled Head Components



Head Reassembly

Step 1 Inspect All Head Components – All head components should be free from scratches, foreign matter, or any sign of damage. Please see Step 6 above for additional information about cleaning head components. Scratched or damaged components should be replaced with ROPV supplied replacement components. All o-rings should be carefully inspected for signs of damage. It is recommended that all o-rings be replaced during each complete servicing of the vessel. Failure to do so may cause poor system performance.

Step 2 Install Sealing Plate O-rings – All o-rings should be coated with a thin layer of glycerine before installation. Care should be taken to minimize the amount of glycerine and any excess should be removed. One o-ring should be placed into each groove located on the inside diameter of the port hole in the sealing plate, including the Feed/Concent Port, Permeate Port, and Adapter Port. Make sure o-rings are completely seated in the grooves.



Step 3 Assemble Permeate Port – Install the permeate port into the sealing plate.



Step 4 Assemble Feed/Concentrate Port – Place the feed/concentrate port in the sealing plate opening and secure using the two feed/concentrate port fixtures.



Step 5 Assemble the Bearing Plate – Position the bearing plate over the sealing plate, pushing them together so that the threaded portion of the permeate port is visible. Connect the bearing plate and sealing plate with the two interlock screws. A hex wrench can be used to secure the screws.



Step 6 Install Adapter O-rings –All o-rings should be coated with a thin layer of glycerine before installation. Care should be used to minimize the amount of glycerine applied and any excess should be removed. Seat one o-ring into each of the two grooves located at the element end, inside diameter of the adapter.



Step 7 Install Adapter – The adapter should be pushed into the permeate port until the wider diameter middle section is flush against the end of the permeate port. Simultaneously pushing and turning the adapter will ease installation.

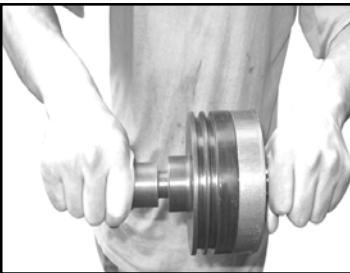

Step 8 Install Head O-ring - All o-rings should be coated with a thin layer of glycerine before installation. Seat the head o-ring into the groove on the outside diameter of the head.

Head Installation

Step 1 Follow All Steps Outlined in the Head Reassembly Section

Step 2 Install Head – Hold the head assembly with both hands, square to the axis of the vessel. Push firmly with both hands until the head is correctly positioned and the retaining groove is visible. It may be necessary to use a rubber mallet to tap the head into its engaged position. The thrust cone must be installed with the head at the downstream end of the vessel.

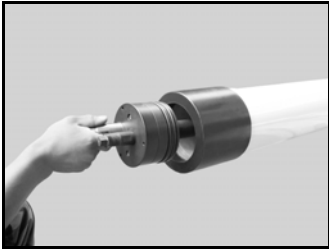

Step 3 Install Locking Kit Segments – Clean and dry the retaining groove. Position the first two locking segments (No.1 and No.2 in picture) so that the end section sits in the retaining groove. Position the third locking segment (No.3) into the last area. Position the securing ring as shown and use a hex wrench to tighten the screw until snug. Do not over-tighten – maximum torque guideline: 10Nm. Install the two other segments in the same manner. Conduct a final tightness check of each screw after all three segments are installed.

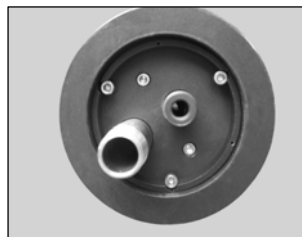
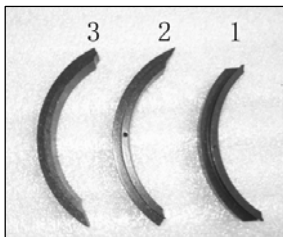

Step 4 Reconnect Permeate Piping – Reconnect the system permeate piping to the permeate port.

Step 5 Pressurize System – A thorough pre-pressurization inspection should be conducted, including verifying that the heads are properly installed, system piping connections are in place, elements are installed, adapters are installed, and thrust cone is installed at downstream end of the vessel.

Step 6 Inspect for Leaks – All connections should be free from leaks. Do not operate leaking vessels.

Piping and Mounting Recommendations

Do not force any connections.

The Header and related piping should be self-supported.

Space strap/saddle locations using “S” dimension shown in model engineering drawing. -4 and longer vessels have a third strap/saddle assembly, to be installed at the center point of the vessel.

Tighten straps to hand tightness plus one turn.

Manifold span should be greater than vessel span to allow for vessel growth under pressure.

R40 E Series Parts List

Part Name	R40 600E	R40 800E	R40 1000E	R40 1200E
Shell	4031.1-6	4031.7-12	4031.13-18	4031.19-24
Bearing Plate	4036			
Sealing Plate	4068(Connect with Adapter 4021) / 4068.1(Connect with Adapter4021.1)			
Shell Collar	4089.1			
Plug	4013			
Permeate Port	4022			
Interlock Screw	4025			
Feed/Conc. Port Fixture	4039			
Locking Segment Screw	4023			
Feed/Conc. Port	4038			
Locking Kit Segment	4024			
Saddle	4010			
Adapter	4021(Connect with Sealing plate 4068) / 4021.1(Connect with Sealing plate 4068.1)			
Strap	4008.2			
Strap Screw	4009			
Head O-ring	4041			
Adapter O-ring	4071(Connect with Sealing plate 4068) / 4071.1(Connect with Sealing plate 4068.1)			
Permeate Port O-ring	4027.1(Connect with Adapter4021) 4027.2(Connect with Adapter4021.1)			
Permeate Port O-ring	4026(Connect with Permeate Port)			
Feed/Concentrate Port O-ring	4035			

Note: Please see the adapter list to get full series adapter

ROPV Limited Warranty

Harbin ROPV Industry Development Center (hereinafter called "ROPV") vessels (the "Product") are warranted to the original purchaser (the "Customer") under normal use and if installed, operated and maintained in accordance with applicable User Guides to be free of defects in material and/or workmanship for a period of one (1) year from date of manufacture subject to the following. Any replacement Product or Part will be warranted only for the remainder of the original warranty period or thirty (30) days, whichever is longer.

Exclusions from this Limited Warranty

The warranty shall be void if:

1. defects are not reported during the warranty period.
2. the Product is subject to accident, damage, incorrect installation, mishandling, abuse, misuse, negligence or accident by any other party.
3. problems caused by modification or alteration.
4. chemical exposure or acts of nature.
5. any item manufactured by other companies.
6. wear on replaceable components under normal conditions – seals are excluded from this warranty.

Procedure for Obtaining Warranty Performance

ROPV reserves the right to determine if a reported defect is a breach of this warranty. This may require, at ROPV's discretion, one or more of the following: 1. an inspection or test of the Product and/or the system in which it was installed by an ROPV representative - the customer is responsible for arranging access to the Product. 2. an inspection or test of the product and/or the system in which it was installed by the Customer. 3. an inspection or test of the product and/or the system in which it was installed by third party inspector appointed by ROPV. 4. return of the Product to ROPV's factory for inspection or testing. This is not a statement of limitations for warranty performance and ROPV reserves the right to conduct warranty performance outside of the items shown.

If the Product is found by ROPV to be defective under the terms of this warranty, ROPV will perform one of the following at its option: 1. supply a substantially similar replacement part based on FOB factory terms. 2. conduct a field repair of the Product. 3. issue a credit for the original cost of the Products. This is not a statement of limitations for warranty performance and ROPV reserves the right to conduct warranty performance outside of the items shown.

Products returned to ROPV for inspection or testing must be shipped freight prepaid at the Customer's expense. If a breach of warranty is confirmed, ROPV will bear all costs related to the inspection and testing. If the Product failure is found to be caused by cause other than breach of warranty, all costs related to the inspection and testing of the Product will be borne by the Customer. This includes a USD\$500 per day fee and all related travel expenses.

All reported defects must be submitted to ROPV in writing.

Disclaimer

ROPV makes no expressed or implied warranty other than that specifically set forth in this warranty statement. ROPV disclaims any warranty of merchantability or of fitness for a particular purpose. ROPV's liability under the terms of this warranty shall not exceed the purchase price of the Product which are claimed to be defective. ROPV shall not be liable for any consequential or incidental damages whatsoever, including but not limited to injuries or damages to person or property, loss of business profits, business interruption, loss of use, cost of removing/installing Products, or the claims of third parties.

Warranties or Representations by Others

No agent, employee, dealer, or other person has any authority to make any warranties or representations concerning ROPV or the Product. ROPV is not responsible for such claims of warranty or representation.

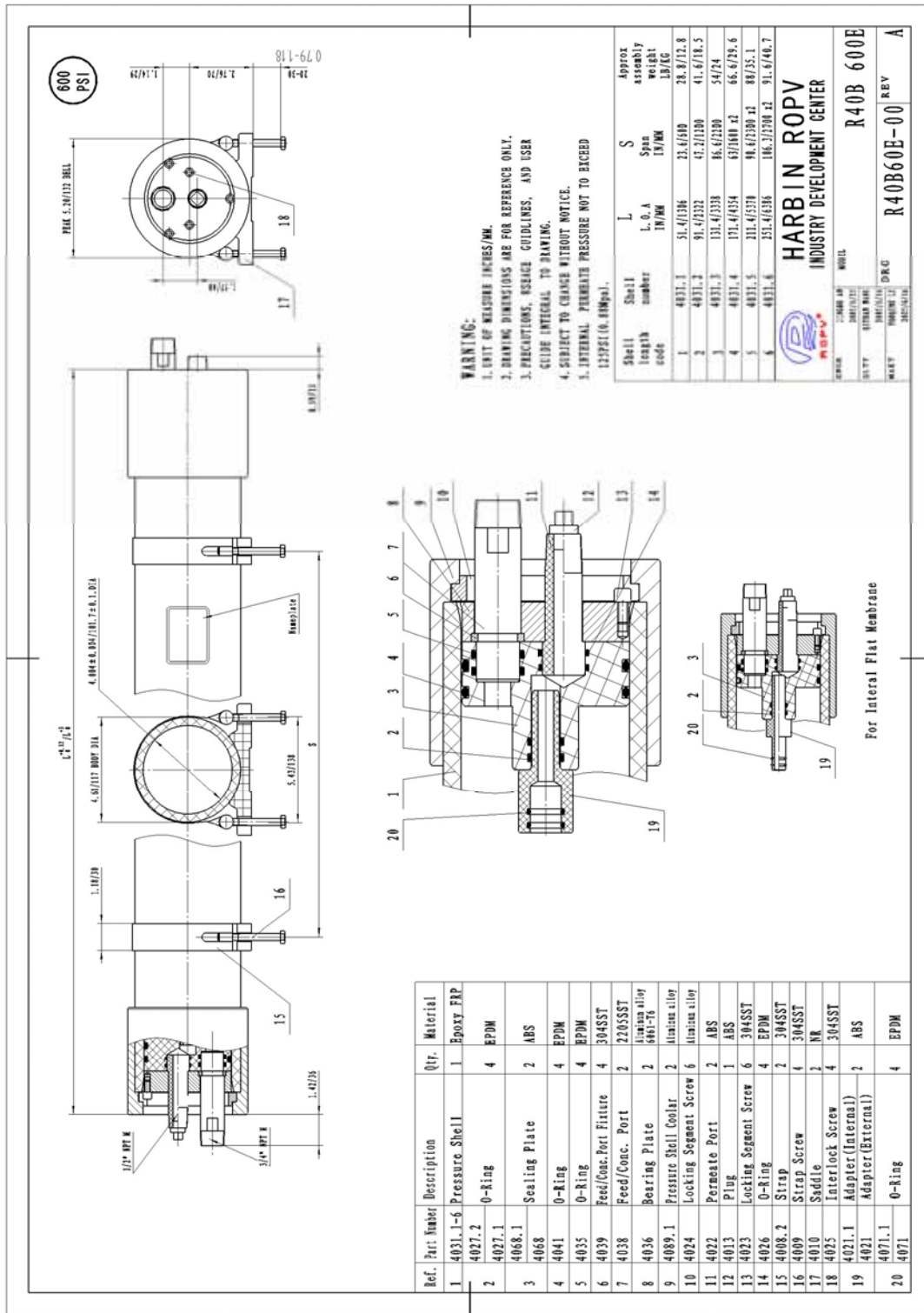

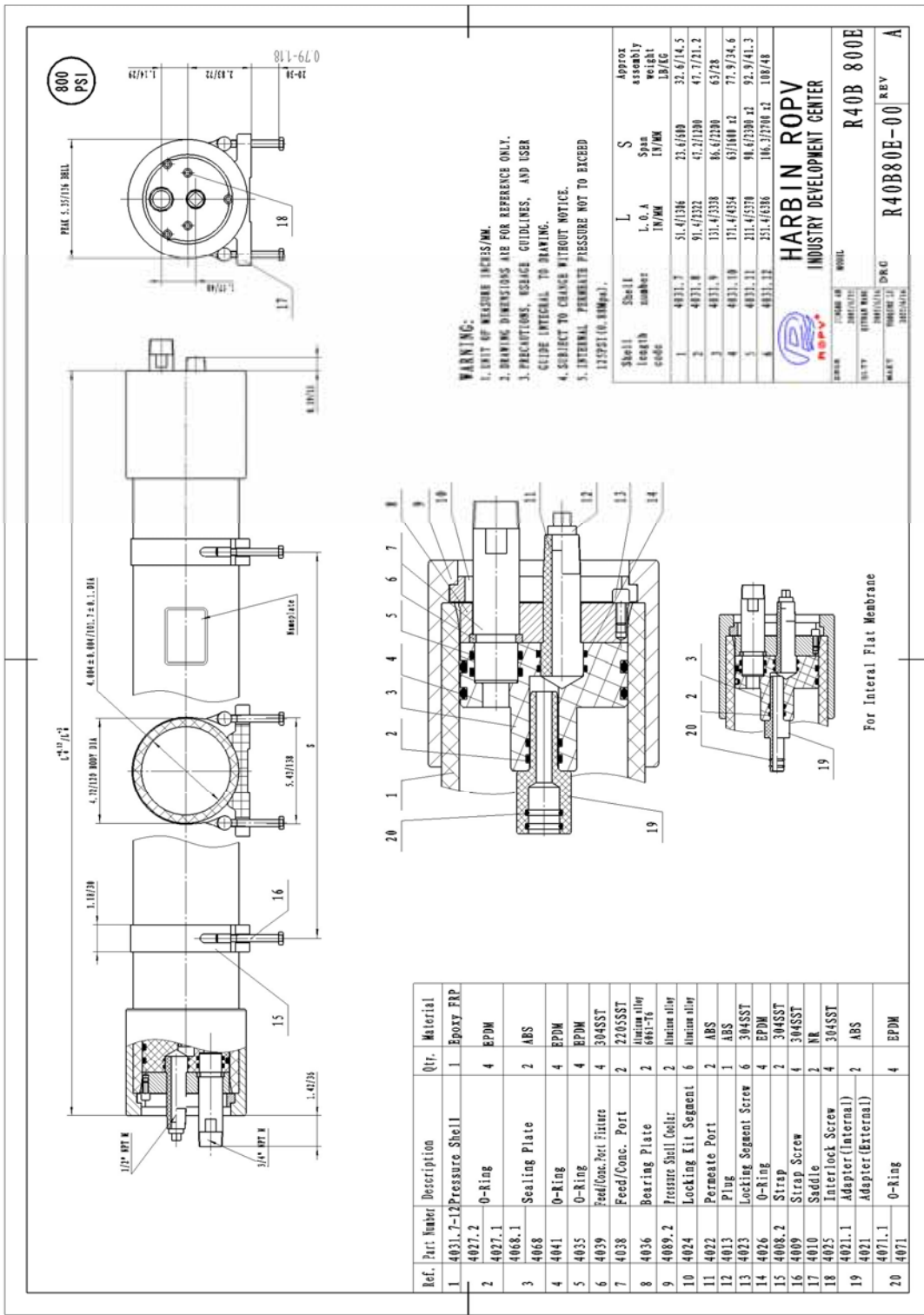

WARNING:
 1. UNIT OF MEASURE INCHES/MM.
 2. DRAWING DIMENSIONS ARE FOR REFERENCE ONLY.
 3. PRECAUTIONS, USAGE GUIDELINES, AND USER GUIDE APPLICABLE TO DRAWING.
 4. SUBJECT TO CHANGE WITHOUT NOTICE.
 5. INTERNAL PERMEATE PRESSURE NOT TO EXCEED 127PSI (0.8MPa).

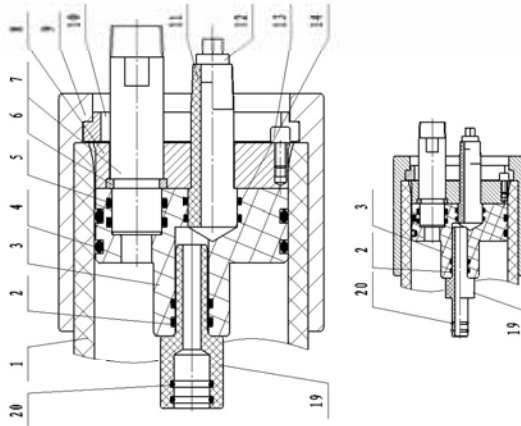

For Internal Flat Membrane

Shell length code	Shell number	L IN/MM	L.O.A IN/MM	S IN/MM	Approx assembly weight LB/EG
1	4831.7	51.4/1316	23.4/590	32.6/714.5	
2	4831.8	91.4/2322	47.2/1190	47.7/21.2	
3	4831.9	131.4/3338	86.4/2190	63/28	
4	4831.10	171.4/4354	127/3100	77.9/34.6	
5	4831.11	211.4/5370	167.4/4200	92.9/41.3	
6	4831.12	251.4/6386	208.4/5100	108/48	

HARBIN ROPV
INDUSTRY DEVELOPMENT CENTER

FROM AN INDUSTRIAL DESIGN
 TO A HIGHLY EFFICIENT
 DESIGN
 FROM AN INDUSTRIAL DESIGN
 TO A HIGHLY EFFICIENT
 DESIGN

R40B 800E

R40B800E-00 REV A
 PART NO. REV. NO.

Ref. Part Number	Description	Qty.	Material
1	4031.7-12 Pressure Shell	1	EPOXY FRP
2	4027.2 O-Ring	4	EPDM
3	4068.1 Sealing Plate	2	ABS
4	4041 O-Ring	4	EPDM
5	4035 O-Ring	4	EPDM
6	4039 Feed/Conc. Port Fixate	4	304SST
7	4038 Feed/Conc. Port	2	220SSST
8	4036 Bearing Plate	2	Union Alloy 6861-16
9	4089.2 Pressure Shell Collr.	2	Union Alloy
10	4024 Locking Kit Segment	6	Union Alloy
11	4022 Permeate Port	2	ABS
12	4013 Plug	1	ABS
13	4023 Locking Segment Screw	6	304SST
14	4026 O-Ring	4	EPDM
15	4088.2 Strap	2	304SST
16	4009 Strap Screw	4	304SST
17	4010 Saddle	2	NR
18	4025 Interlock Screw	4	304SST
19	4021 Adapter (Internal)	2	ABS
20	4071.1 Adapter (External)	4	EPDM

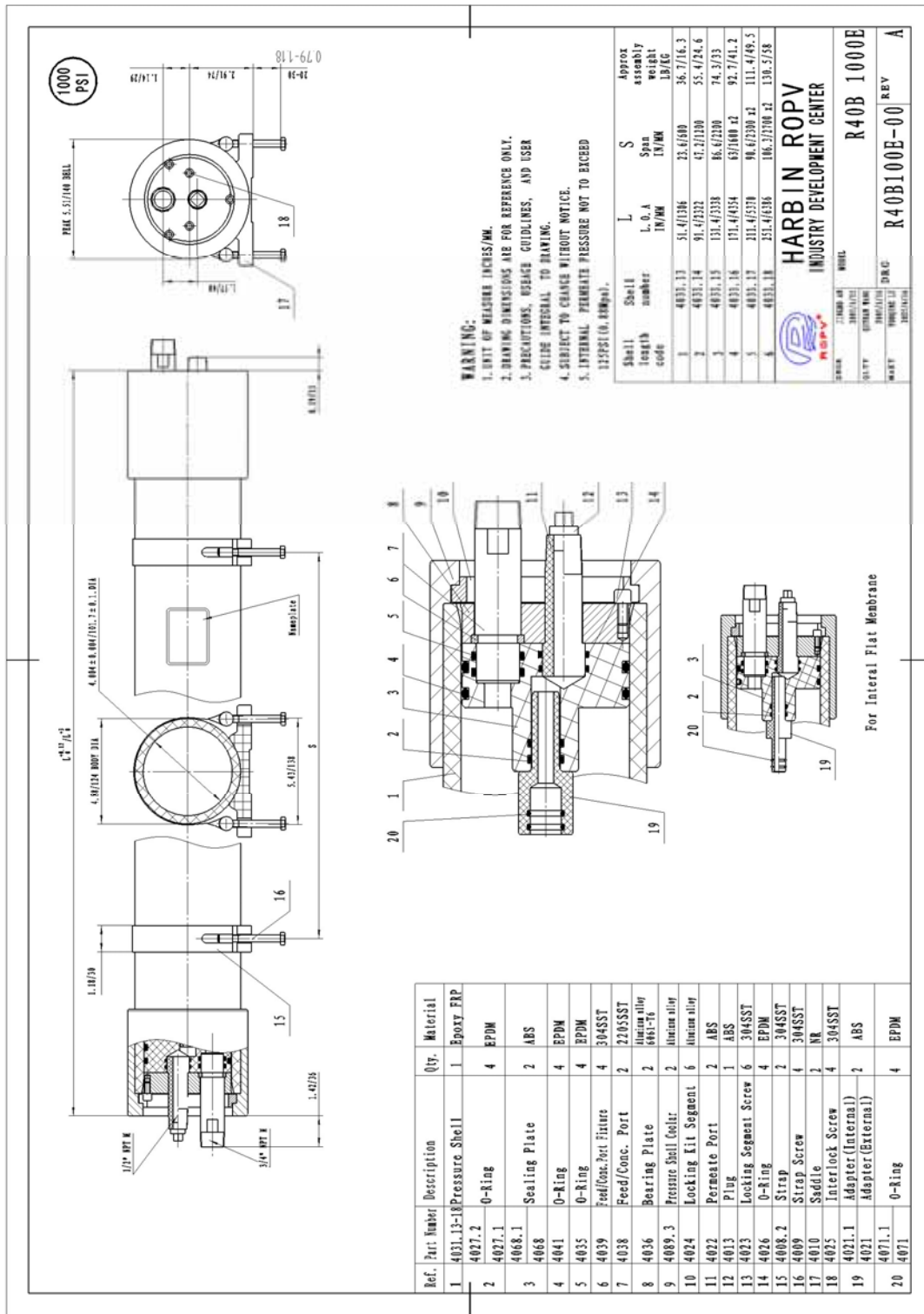

WARNING:
 1. ALL DIMENSIONS ARE IN INCHES/MM.
 2. DRAWING DIMENSIONS ARE FOR REFERENCE ONLY.
 3. PRECAUTIONS, USAGE GUIDELINES, AND USER GUIDE INTEGRAL TO DRAWING.
 4. SUBJECT TO CHANGE WITHOUT NOTICE.
 5. INTERNAL PERMEATE PRESSURE NOT TO EXCEED 1200PSI (8.10MPa).

Shell length code	Shell number	L IN/MM	S IN/MM	Approx assembly weight LB/KG
1	4037.19	51.4/1316	23.6/600	62.8/19
2	4037.20	91.4/2332	47.2/1200	69.8/21
3	4037.21	131.4/3338	86.6/2200	97.8/28.5
4	4037.22	171.4/4354	67/1800 ±2	125.1/35.6
5	4037.23	211.4/5370	91.6/2300 ±2	157/68
6	4037.24	251.4/6386	106.3/2700 ±2	180/80

Ref. Part Number	Description	Qty.	Material
1	4031.19-14 Pressure Shell	1	Epoxy FRP
2	4027.2 O-Ring	4	EPDM
3	4068.1 Sealing Plate	2	ABS
4	4041 O-Ring	4	EPDM
5	4035 O-Ring	4	EPDM
6	4039 Feed/Conc. Port Fitting	4	304SS
7	4038 Feed/Conc. Port	2	2205SS
8	4036 Bearing Plate	2	Aluminum 6061-T6
9	4089.4 Pressure Shell Cooler	2	Aluminum
10	4024 Locking Kit Segment	6	Aluminum
11	4022 Permeate Port	2	ABS
12	4013 Plug	1	ABS
13	4023 Locking Segment Screw	6	304SS
14	4026 O-Ring	4	EPDM
15	4008.2 Strap	2	304SS
16	4009 Strap Screw	4	304SS
17	4010 Saddle	2	IN
18	4025 Interlock Screw	4	304SS
19	4021.1 Adapter (Internal)	2	ABS
20	4071.1 Adapter (External)	2	ABS
20	4071 O-Ring	4	EPDM

HARBIN ROPV
 INDUSTRY DEVELOPMENT CENTER

MODEL: R40B 1200E
 DRAWING NO: R40B1200E-00
 REV: A