

Campagnolo[®]

11TM
SPEED

REAR DERAILLEUR

EPSTM

**WARNING!**

Carefully read, follow and understand the instructions given in this manual. It is an essential part of the product, and you should keep it in a safe place for future reference.

MECHANIC QUALIFICATION - Please be advised that many bicycle service and repair tasks require specialized knowledge, tools and experience. General mechanical aptitude may not be sufficient to properly service or repair your bicycle. If you have any doubt whatsoever regarding your service/repair ability, please take your bicycle to a qualified repair shop.

INTENDED USE - This Campagnolo® product is designed and manufactured for use only on road racing style bicycles that are ridden **only** on smooth road or track surfaces. Any other use of this product, such as off-road or on trails **is forbidden**.

"AN ACCIDENT" - Please note that throughout this manual, reference is made that "an accident" could occur. Any accident could result in damage to your bicycle, its components and, more importantly, could cause you or a bystander to sustain severe personal injury or even death.

LIFESPAN - WEAR - INSPECTION REQUIREMENT - The lifespan of Campagnolo® components depends on many factors, such as rider size and riding conditions. Impacts, falls, improper use or harsh use in general may compromise the structural integrity of the components and significantly reduce their lifespan. Some components are also subject to wear over time. Please have your bicycle and its components regularly inspected by a qualified mechanic for any cracks, deformation, signs of fatigue or wear. Disassembly your bicycle components and especially the pedals, is required during these inspections. If the inspection reveals any deformation, cracks, impact marks or stress marks, no matter how slight, **immediately** replace the component; components that have experienced excessive wear also need **immediate** replacement. The frequency of inspection depends on many factors; check with your authorized representative of Campagnolo S.r.l. to select a schedule that is best for you. If you weigh 82 kg/180 lbs or more, you must be especially vigilant and have your bicycle inspected more frequently (than someone weighting less than 82 kg/180 lbs) for any evidence of cracks, deformation, or other signs of fatigue or stress. Check with your mechanic to discuss whether the components you selected are suitable for your use, and to determine the frequency of inspections.

Important PERFORMANCE, SAFETY and WARRANTY Notice - Dear customer, please remember that to maximise the performance of your EPS drivetrain and to prevent jeopardising its safety, performance, long-life and functionality, it is absolutely necessary to use the 6 components of EPS drivetrain with components of the Campagnolo 11 speed mechanical drivetrain; it is not possible to use EPS components that are not manufactured by Campagnolo.

Note: Tools supplied by other manufacturers for components similar to Campagnolo® components may not be compatible with Campagnolo® components. Likewise, tools supplied by Campagnolo S.r.l. may not be compatible with components supplied by other manufacturers. Always check with your mechanic or the tool manufacturer to insure compatibility before using tools supplied by one manufacturer on components supplied by another.

The user of this Campagnolo® product expressly recognizes that there are risks inherent in bicycle riding, including but not limited to the risk that a component of the bicycle can fail, resulting in an accident, personal injury or death. By his purchase and use of this Campagnolo® product, the user expressly, voluntarily and knowingly accepts and/or assumes these risks and agrees to hold Campagnolo S.r.l. harmless against any resulting damages.

If you ever have any questions, please contact your mechanic or your nearest Campagnolo® dealer for additional information.

**WARNING!**

Always wear protective gloves and glasses while working on the rear derailleur.

1 - PREPARING THE FRAME

Clear the threading of the rear derailleur connection fitting on the right rear dropout (B - Fig. 1) using a tool tap with threading 10x26 TPI.

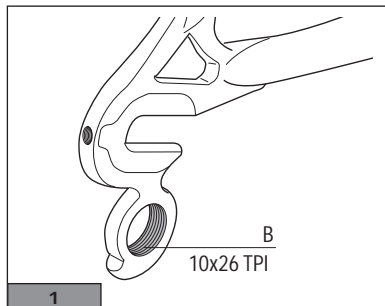
**CAUTION**

Check and, if necessary, realign the rear derailleur dropout only by using Campagnolo® tool UT-VS030.

NEVER straighten the dropout with the rear derailleur assembled because you could damage the dropout and cause irreparable damage or loss in functionality to your rear derailleur.

When installing/removing or servicing components, switch off the EPS drivetrain as indicated in the instruction sheet of the EPS Power Unit.

2 - ASSEMBLY**! WARNING!**

THE EPS REAR DERAILLEUR MUST BE MOUNTED AND CONNECTED ONLY AND EXCLUSIVELY BY ONE OF CAMPAGNOLO'S SERVICE CENTERS, A CAMPAGNOLO PRO-SHOP OR A MECHANIC SPECIALISED IN MOUNTING EPS GROUPSETS.

PLEASE REMEMBER THAT TAMPERING OR INCORRECT OR INCOMPLETE INSTALLATION OF EVEN JUST ONE COMPONENT OF THE EPS GROUPSET AUTOMATICALLY RESULTS IN THE INVALIDATION OF ANY WARRANTY.

! NOTE FOR SPECIALISED MECHANICS!

Please remember that all assembly, disassembly, adjustment and maintenance procedures for the EPS drivetrain are described in the EPS technical manual, which is available in PDF format on our internet site www.campagnolo.com.

- Secure the rear derailleur to the frame using screw (A - Fig. 2), and tighten with a TORX T-25 key.

Tightening torque: **15 Nm - 133 in.lbs**

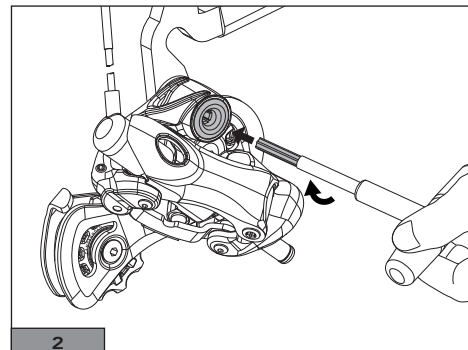

2.1 - ZERO SETTING of the rear derailleur

! WARNING!

Resetting the rear derailleur to zero is a particularly delicate operation and must be carried out when the bicycle is stationary and placed on a stand. This is why it should be conducted only and exclusively by a Campagnolo Service Center, a Campagnolo Pro-shop or a mechanic specialised in mounting EPS groupsets.

2.2 - RIDING SETTING of the rear derailleur

The setting procedure allows to adjust the reference position of the rear derailleur and is particularly useful if you intend to change the wheel with one with a set of sprockets that are positioned differently with respect to the drop-out.

To adjust the rear derailleur, press and hold the MODE button (D - Fig.3) on the EPS controls for approximately 6 seconds until the purple LED turns on.

Adjust the position by pressing lever B or lever C on the left control (Fig. 3).

Note

Every time lever B or lever C (Fig. 3) is pressed, this allows the system to carry out a fixed shift of approximately 0.2 mm.

When you have completed the procedure, the system will correct the established positions of all the chainrings based on the new settings.

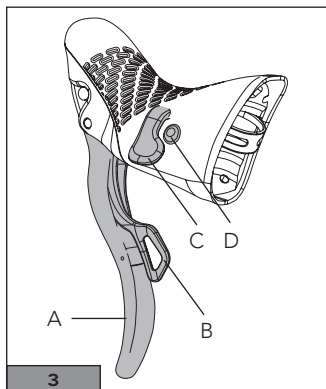

If the chain is perfectly centred, from the 2nd to the 10th pinion:
the chain moves closer to the lower pinion by moving 3 times downwards
the chain moves closer to the upper pinion by moving 3 times upwards

To save the adjustment, briefly press the MODE button located on the EPS controls (D - Fig.3).

IMPORTANT!

If you do not press the MODE key briefly, which allows to complete the setting procedure, the system will automatically exit the procedure after 48 seconds and will save the new setting.

Every time a resetting to zero is conducted, previous adjustments are reset.

! WARNING!

Setting the rear derailleur when the bicycle is in motion may result in dangerous situations and cause accidents. Therefore please be very careful if you decide to do it.

3 - REMOVAL

When installing/removing or servicing components, switch off the EPS drivetrain as indicated in the instruction sheet of the EPS Power Unit.

! WARNING!

THE EPS REAR DERAILLEUR MUST BE DISASSEMBLED ONLY AND EXCLUSIVELY BY ONE OF CAMPAGNOLO'S SERVICE CENTERS, A CAMPAGNOLO PRO-SHOP OR A MECHANIC SPECIALISED IN MOUNTING EPS GROUPSETS.

4 - MAINTENANCE

When installing/removing or servicing components, switch off the EPS drivetrain as indicated in the instruction sheet of the EPS Power Unit.

- Lubricate all the joints regularly.
- If the rollers do not rotate smoothly, clean thoroughly and replace if necessary.
- To remove the rollers, unscrew the screws (E - Fig. 4) with a 3 mm Allen screw.

ATTENTION!

The two rollers are different: on the upper section, fit the roller marked "UPPER" (with side play); in the lower section, fit the roller marked "LOWER": it is unidirectional and must be fitted so that it rotates in the direction indicated by the arrows (Fig. 5).

WARNING!

Comply with the following specifications when replacing the pulleys:

Tightening torque

2,7 Nm - 24 in.lbs

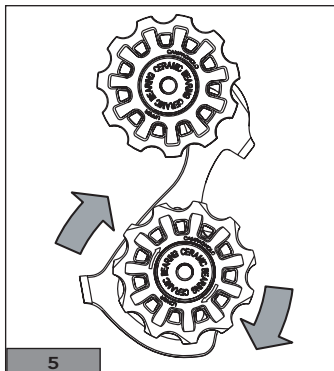
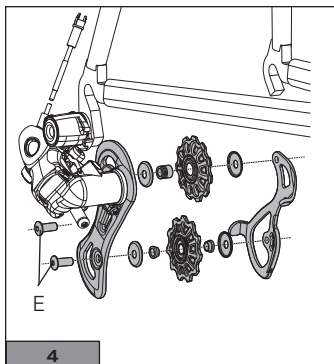

- The life of the components depends on conditions of use and on the frequency and quality of maintenance. To keep the components in good condition, cleaning and lubrication must therefore be repeated frequently, especially if it is subjected to heavy-duty use (i.e. after washing your bicycle, after every ride in wet, dusty or muddy conditions etc.).

- Dirt seriously damage bicycles and their components. Thoroughly rinse, clean and dry your bike after using it in these conditions.
- Never spray your bicycle with water under pressure. Pressurized water, even from the nozzle of a small garden hose, can pass seals and enter into your Campagnolo® components, damaging them beyond repair. Wash your bicycle and Campagnolo® components by wiping them down with water and neutral soap. Dry them using a soft cloth. Never use abrasive or metal pads.
- Before lubricating, thoroughly clean the drive system (chain, sprocket set, chainrings and derailleur pulleys) with a brush or cloth saturated with an appropriate degreaser or detergent.
- Relubricate the components carefully using a lubricant suitable to purpose.
- Using poor-quality or incorrect lubricant may damage the chain and cause excessive wear or damage to the system. A damaged drive system can malfunction, resulting in an accident, personal injury or death.
- After applying the lubricant move the cranks and engage all possible gear combinations in order to thoroughly lubricate the entire drive system.
- Thoroughly clean any residual lubricant from the bicycle and floor.
- At the end of the lubrication operation, CAREFULLY degrease rims and brake pads.



WARNING!

Traces of lubricant on the rims and brake pads can reduce or eliminate the braking capabilities of your bicycle, resulting in an accident, personal injury or death.

5 - "UNHOOK" MECHANISM

In case of falling or accidental blows to the rear derailleur, the "unhook" mechanism could be triggered which frees the rear derailleur parallelogram from its diagonal (in order to avoid damaging it). You will notice this because the rear derailleur will not go below the 2nd or 1st sprocket.

We recommend to take the rear derailleur to the smallest reachable sprocket, stop pedalling and act repeatedly on lever 2. In order to verify whether the rear derailleur is hooked again, drop down to the 1st sprocket: If this has not occurred "manually force" the rear derailleur.

After successful rehooking, check the alignment of the drop-out/rear derailleur mount and proper operation of the rear derailleur.

Hooked rear derailleur position (Fig.6).

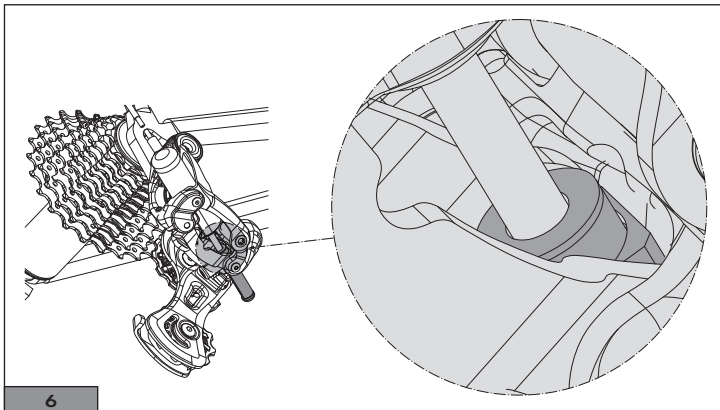

5.1 - «RIDE BACK HOME» FUNCTION

If the battery goes flat «on the road», it is possible to use the "unhook" feature of the rear derailleur (Fig. 7) in order to be able to move the rear derailleur position onto the required sprocket.

Once back home remember to hook the rear derailleur back (Fig. 8) and to charge the battery.

