

# PowerBrick™

## User's Manual Edition 3.1

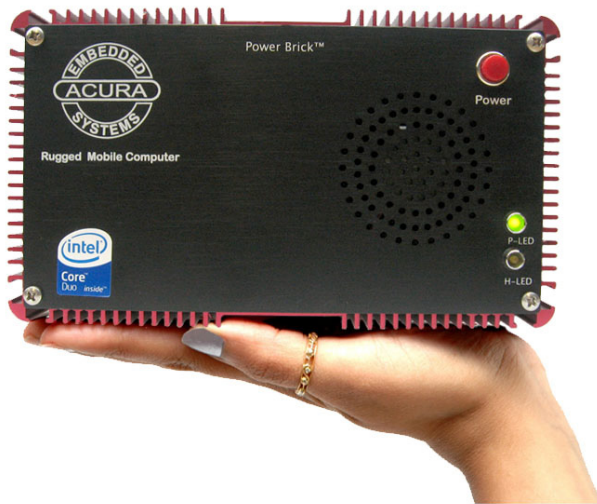

*Small footprint rugged Intel® Core™ Duo*

*Industrial Computer*



### Disclaimer

Acura Embedded Systems Inc. takes every care in the preparation of this document, but no guarantee is given as to the correctness of its contents. Our products are under continual improvement and we reserve the right to make changes without notice. The manufacturer makes no representations or warranties with respect to the contents hereof and specifically disclaim any implied warranties of merchantability or fitness for any particular purpose. The manufacturer reserves the right to revise this publication and to make changes from time to time in the content hereof without obligation of the manufacturer to notify any person of such revision or changes.

In general, the manufacturer will not be liable for loss of data or other direct, indirect, special, incidental or consequential damages arising from the use or inability to use the product or documentation, even if advised of the possibility of such damages.

**Preface**

**Copyright**

The material in this document is the intellectual property of Acura Embedded Systems Inc. This publication, including all photographs, illustrations and software, is protected under international copyright laws, with all rights reserved. Neither this manual, nor any of the material contained herein, may be reproduced without written consent of Acura Embedded Systems Inc.

Version 3.1

**Trademark Recognition**

Microsoft, MS-DOS and Windows are registered trademarks of Microsoft Corp.

IBM PC is a registered trademark of International Business Machines Corporation.

Intel, MMX, Pentium, Pentium-II, Pentium-III, Pentium-4, Celeron, Core™ Duo are registered trademarks of Intel Corporation.

AWARD is a registered trademark of AWARD International Inc.

Other product names used in this manual are the properties of their respective owners and are acknowledged

**Table of Content**

**1. OVERVIEW..... 1**

**2.INSTALLATION..... 2**

    2.1 CONTENTS OF THE COMPUTER BOX..... 2

    2.2 CONNECTING CABLES AND GETTING STARTED..... 2

**2.3 MOUNTING IN YOUR VEHICLE (FINAL LOCATION)..... 4**

    2.4 MOUNTING TOOLS..... 4

**2.5 COMPUTER INSTALLATION..... 4**

**3. TECHNICAL INFORMATION..... 5**

    3.1 BIOS SETUP..... 5

**3.2 OPERATING SYSTEMS..... 6**

**3.3 OPERATING SYSTEM RESTORE PROCESS..... 6**

    3.4 WINDOWS EMBEDDED XP..... 7

    3.5 LINUX EMBEDDED..... 7

    3.6 APPLICATION SOFTWARE..... 7

    3.7 SPECIFICATIONS FOR POWERBRICK..... 7

    3.8 OPERATION AND MAINTENANCE..... 8

    3.9 WARNING..... 9

**3.9A POWER BRICK WIRING DIAGRAM..... 9**

**4. CONTACT NFORMATION.....10**

## 1. Overview

The PowerBrick is a *Intel® Core™ 2 Duo* system with 2.0 GHz processor speed. This small, rugged and powerful computer is the premium choice when desktop computer performance is required in industrial computing applications. Small size does not necessarily mean limitations in computing power.

The state-of-the-art PowerBrick comes loaded with an impressive video card, fast hard drive (or optional flash drive) and memory, all at a competitive price. It is designed and built for great performance in a variety of applications and environments. The design focuses on elements essential for industrial use while excluding unnecessary hardware. The architecture is modular which allows for easy upgrading and expansions.

Areas of applications include:

- Fire engines and rescue vehicles
- Security and patrol vehicles
- Other emergency or public safety vehicles
- Cash carriers
- Seaport terminal container yard management
- Fleet management

The main features are:

- *Intel® Core™ Duo* processor (2.0 GHz)
- Standard 2.5" hard disk, 160GB
- 1 GB DDR2 RAM
- 4 x RS232 Port
- 4 x USB 2.0 Port
- 2 x On-board 10/100/1000 LAN Port
- 1 x Compact flash II Port
- Audio Jacks
- Built-in 8~30 VOLT DC
- Ignition controller (optional)
- Embedded OS (optional)
- Wireless 802.11bgn (optional)
- GSM/GPRS/WiFi/CDMA/CDPD options
- GPS/AVL options
- Dimensions: 7.6" x 5" x 4.13" (W x L x H)

For installation, mounting and cable connections please see Section 2. Technical information is available in Section 3.

## 2. Installation

### 2.1 Contents of the Computer Box



**Figure 2.1** Box major components

In the box you will find the following items: PowerBrick computer, power plug, mounting plate equipped with rubber suspension, 4 bolts

If you have purchased Windows or Linux operating system with your computer, these CD's should be included. Keep them in a safe place.

Please see your separate monitor packaging for installation and other information for the touch screen monitor.

**Do not turn power on until you have read the next section and all cables are connected.**

### 2.2 Connecting Cables and Getting Started

In order to get familiar with your system before mounting it in your vehicle (or final location), we suggest you look at the connections on both ends of the computer such as shown in Figs. 2.2 and 2.3, connect up the unit, and place it into operation.

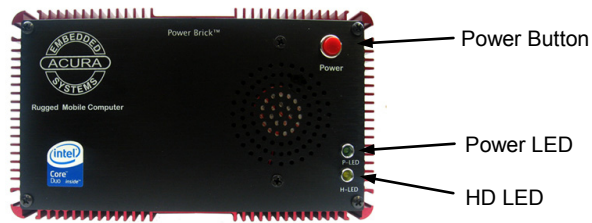

**Figure 2.2: Front side of PowerBrick**

Connect all applicable cables such as:

- Keyboard
- Mouse
- Monitor
- Power supply cable

Optional device cables or units that you provide yourself could include the following:

- USB cable
- Speaker and microphone cables
- RJ45 Ethernet TP cable
- RS232 Serial port cable
- Ignition controller

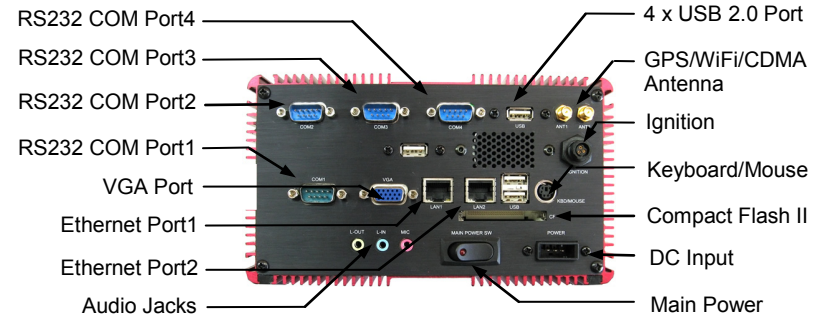

**Figure 2.3 : Backside of PowerBrick**

After connecting all applicable cables it is safe to power-on the system. (Warning: use only DC from the dedicated power supply)

### 2.3 Mounting in your vehicle or final location

This chapter provides you with the information of fixed system mounting. Prior to that, please prepare the installation tools and appropriate items. If you are not clear about the items, contact your dealer for information.

### 2.4 Mounting tools

For mounting your computer in a vehicle you need the following tools:

- Wrench
- Screw driver
- Drill
- Bolts and nuts appropriate to mount the plate in your vehicle

### 2.5 Computer installation

Mounting screws or bolts and nuts for mounting to your specific vehicle are not provided, as there are many variations of thickness that the unit might be mounted to. If mounting in a vehicle that is subject to vibration and shock, It is important to use the mounting plate with attached shock absorbers where vibration could occur. The mounting plate should be fastened tightly with bolts and nuts. Please ensure that if you mount any bolts/nuts under the computer, that they do not touch the computer itself. Otherwise, the shock absorbers will not protect the computer properly.



**Figure 2.4: Rubber-Mounting plate**

Connect all final wiring neatly, fastening it down with tie straps or other means to ensure that it does not get caught and broken accidentally. Your car electrician will know appropriate ways to do this.

**3. Technical Information**

**3.1 BIOS Setup**

The single board computer uses the AMI BIOS (Basic Input/Output System) for the system configuration. The AMI BIOS in the single board computer is a customized version of the industrial standard BIOS for IBM PC AT-compatible computers. It supports Intel x86 and compatible CPU architecture based processors and computers. The BIOS provides critical low-level support for the system central processing, memory and I/O sub-systems. The BIOS setup program of the single board computer let the customers modify the basic configuration setting. The settings are stored in a dedicated battery-backed memory, NVRAM, retains the information when the power is turned off. If the battery runs out of the power, then the settings of BIOS will come back to the default setting. The BIOS section of the manual is subject to change without notice and is provided here for reference purpose only. The settings and configurations of the BIOS are current at the time of print, and therefore they may not be exactly the same as that displayed on your screen. To activate CMOS Setup program, press <DEL> key immediately after you turn on the system. The following message “Press DEL to enter SETUP” should appear in the lower left hand corner of your screen. When you enter the CMOS Setup Utility, the Main Menu will be displayed as in Table 3.2. You can use arrow keys to select your function, press <Enter> key to accept selection and enter the sub-menu.



**Table 3.1: AMI BIOS CMOS Setup Utility**

**3.2 Operating Systems**

The PowerBrick will generally be provided with a preinstalled operating system such as Windows XP Professional, Embedded or Linux. To restore the operating system, follow the procedure outlined in 3.4. You can also use an external CD-ROM drive to change, reinstall or repair the operating system through a USB 2.0 port.

**3.3. Operating System Restore Process**

1. Back up your existing drive C:\ files.
2. Restart the computer.
3. Hold down the F8 key to enter Windows Advanced Boot Menu options.
4. Select “Return to OS Choices” and press “Enter”.
5. Select “Quick Restore Option”, press “Enter” and follow the instructions.
6. After re-boot, Click on the “Touchware” Icon on desktop to Calibrate the touch screen by following the instructions.

### 3.4 Windows XP Embedded

If you want to reinstall Windows XP Embedded, boot the computer, place the CD-ROM labeled “Windows XP Embedded Recovery” into the external CD-ROM drive, presses RESET and follow the instructions on the screen. We recommend that this be done by experienced computer users only.

### 3.5 Linux Embedded

If you want to install Linux, boot the computer, place the CD-ROM labeled “Acura Embedded Linux” into the external CD-ROM drive, press RESET and follow the instructions on the screen. Note: this should only be done by an advanced user who has experience with Linux.

### 3.6 Application Software

You should be able to run all normal/generic application software such as Microsoft Word, Excel, PowerPoint, Adobe software etc. if you have Windows installed. See the relevant manual/help guides for the specific software. For Linux you will have to specifically select software designed for Linux. Acura is not responsible for failure of any software on your computer but if you have any particular software needs, please call Acura Technical Support or email [support@acuraembedded.com](mailto:support@acuraembedded.com).

### 3.7. Specifications for Power Brick

**Table 3.2: Input/Output**

15 Pin VGA	1
PS/2 Keyboard & Mouse	1
RS232 Serial Port	4
USB 2.0	4
RJ45 Gigabit Ethernet Port	2
Compact Flash II	1
Audio Jacks	1
Ignition controller (optional)	1
GPS/WiFi/CDMA antenna (optional)	2
8 ~ 30V DC Power Jack	1

**Table 3.3: System Features**

Processor	Intel® Core™ Duo processor (2.0 GHz)
System FSB	667 MHz
Memory	533MHz/667MHz DDR2 SO-DIMM up to 2GB
Video	Integrated Intel® Extreme 945GM Graphic, support 64MB DVMT
Audio	Audio Jacks
Hard Disk	Standard 2.5" SATA hard disk, 160GB
CD-ROM	None
LAN	Two Broadcom PCIe GbE controllers
USB 2.0	Integrated 4 independent OHCI controller supporting USB 1.1 ports; Integrated 1 EHCI controller supporting USB 2.0 ports; Dynamic connection support to USB 2.0 or USB 1.1 devices
Hardware Monitor	System temperature, voltage and fan speed monitor. Auto Thermal fan speed control
Power Management	ACPI 1.0b compliance and OS direct power management, Wake-on event: RTC/USB Keyboard/Modem/LAN/Keyboard/Mouse
Dimensions	7.60"X 5" x4.13" (W x L x H)
Power	8 ~ 30V DC

### 3.8 Operation and maintenance

This module requires no routine maintenance. The green LED indicator when lit indicates proper operation and health.

The power supply must be protected by a 7A auto fuse on the input line from the vehicle battery.

**3.9 Warning**

Before powering up the computer, make sure all cables connected to the computer and the monitor.

**WARNING**

**First hookup all cables then turn on computer power switch.**

**Make sure monitor power led on or blinking .**

**3.9A PowerBrick Wiring Diagram**

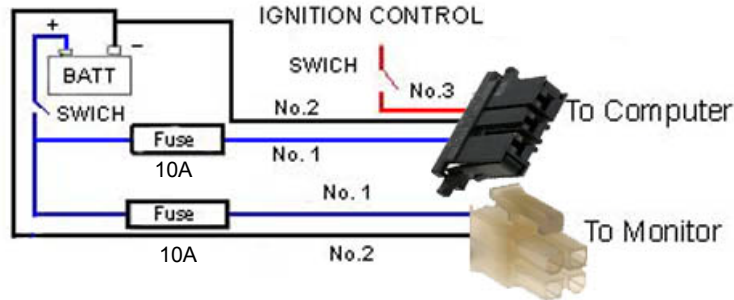

**Computer connector**

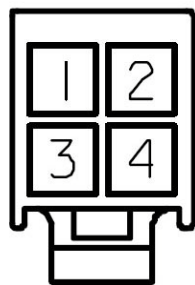

**Monitor Power connector**

(Computer connector : pin1-orange, pin2-black, pin3-purple, for sure power make pin1 and pin3 together)

With the unique set of products, Acura Embedded Systems remains committed to its goal of providing trouble-free and customer-friendly service. A special customer service unit has been set up specifically to cater to our esteemed customers' needs.

Technical Support:

- Phone: 1-866-502-9666
- Email: [support@acuraembedded.com](mailto:support@acuraembedded.com)

Mail address:

**Acura Embedded Systems Inc.**

Unit #1, 7711-128th Street

Surrey, BC V3W 4E6

CANADA

Ph: (604) 502-9666 Fax: (604) 502-9668