



## **VHF Modbus Receiver User Manual**

**Version 2.0**



# Table of Contents

1	WEEE & THE BATTERY DIRECTIVE .....	3
2	INTRODUCTION .....	4
3	INSTALLATION.....	5
3.1	Location.....	5
3.2	LED Indication .....	5
4	CONNECTIONS .....	6
5	CONFIGURATION.....	7
5.1	Dip Switch Settings .....	7
5.2	Programming .....	7
5.3	Addressing Modes.....	8
5.3.1	8-Bit Addressing.....	8
5.3.2	16-Bit Addressing (Extended Addressing Range) .....	8
5.4	Code Examples.....	9
5.4.1	Code 66 – Program Unit ID .....	9
5.4.2	Code 03 – Read Holding Registers (8-Bit Addressing) .....	9
5.4.3	Code 03 – Read Holding Registers (16-Bit Addressing) .....	9
5.4.4	Code 16 – Write Multiple Register (8-bit Addressing).....	10
5.4.5	Code 16 – Write Multiple Register (16-Bit Addressing) .....	10
6	TRANSMITTER TYPES .....	11
6.1	Pulse Transmitter – Type 81 .....	11
6.2	Digital Temperature Transmitter – Type 82.....	11
6.3	Alarm/Status Transmitter – Type 88 .....	12
	APPENDIX 1.....	13
	Memory Map (8-Bit Addressing) .....	13
	Memory Map (16-Bit Addressing) .....	18
	APPENDIX 2.....	22
	Modbus CRC Algorithm.....	22

# 1 WEEE & the Battery Directive

Waste Electrical and Electronic Equipment.

HWM-Water Ltd is a registered producer of Electrical and Electronic Equipment in the United Kingdom (registration number WEE/AE0049TZ). Our products fall under category 9 (Monitoring and Control Instruments) of The Waste Electrical and Electronic Equipment (WEEE) Regulations. We take all environmental issues seriously and fully comply with the requirements for collection, recycling and reporting of waste products.

HWM-Water Ltd is responsible for WEEE from customers in the United Kingdom provided that:

The equipment was produced by HWM-Water Ltd (Palmer Environmental/Radcom Technologies/Radiotech/ASL Holdings Ltd) and supplied on or after 13th August 2005

The equipment was supplied before 13th August 2005 that has been directly replaced HWM-Water Ltd products manufactured since 13th August 2005.

HWM-Water products supplied after 13th August 2005 can be identified by the following symbol:



Under HWM-Water Ltd Terms and Conditions of Sale, customers are responsible for the cost of returning WEEE to HWM-Water Ltd and we are responsible for the costs of recycling and reporting on that waste.

Instructions for returning WEEE:

Ensure that the WEEE meets one of the two conditions above.

The waste will need to be returned in accordance with the regulations for transporting data loggers with lithium batteries.

- a. Pack loggers in strong, rigid outer packaging to protect them from damage.
- b. Attach a Lithium Warning Label to the package.
- c. The package must be accompanied by a document (e.g. consignment note) that indicates:
  - i. The package contains lithium metal cells;
  - ii. The package must be handled with care and that a flammability hazard exists if the package is damaged;
  - iii. Special procedures should be followed in the event the package is damaged, to include inspection and repacking if necessary; and
  - iiii. A telephone number for additional information.
- d. Refer to the ADR regulations on shipping dangerous goods by road.

Return the WEEE to HWM-Water Ltd using a licensed waste carrier.

In accordance with the regulations, customers outside the United Kingdom are responsible for WEEE.

## **The Battery Directive**

As a distributor of batteries HWM-Water Ltd will accept old batteries back from customers for disposal, free of charge, in accordance with the Battery Directive.

PLEASE NOTE: All lithium batteries MUST be packaged and returned in accordance with the relevant regulations for transporting lithium batteries.

---

A licensed waste carrier must be used for transporting all waste.

For more information on WEEE compliance or the Battery Directive please e-mail [CService@hwm-water.com](mailto:CService@hwm-water.com) or phone +44 (0)1633 489 479

**If further support or assistance is required, please contact  
HWM Technical Support on 01633 489479 (option 5)  
or e-mail [support@HWM-Water.com](mailto:support@HWM-Water.com)**

## 2 Introduction

The VHF Modbus receiver has been designed to provide a complete solution for fixed data collection. It is designed to work in conjunction with most of the AMR range of VHF transmitters. The receiver decodes the data, verifies using a 16-bit CRC check (*Appendix 2*) and passes the data packet through to the serial port.



<b>Receiver Frequency:</b>	153.10MHz or 169.40625MHz.
<b>Modbus Mode:</b>	Modbus Slave Remote Terminal Unit (RTU) supported. Slave address configurable.
<b>Number of Devices Supported:</b>	32
<b>Communications Protocol:</b>	RS232 & RS485
<b>Communications Setup:</b>	4800, No Parity, 8-bits, 1-Stop or 9600, No Parity, 8-bits,1-Stop
<b>Functions Codes Supported:</b>	<ul style="list-style-type: none"><li>• 0x03 (03<sub>dec</sub>) Read Holding Registers</li><li>• 0x10 (16<sub>dec</sub>) Write Multiple Registers</li><li>• 0x42 (66<sub>dec</sub>) Special Function Code</li></ul>

### **Operating Environment:**

Operating Temperature Range: -10°C to +40°C (Recommended for indoor use only).

Dimensions: 98 x 198 x 82mm (approx.) excluding connectors and glands.

Protection Rating: IP65 (when sealed).

### **Power Supply:**

Operating Voltage: 12V<sub>DC</sub> from plug top power supply.

### **Enclosure:**

Die-cast Aluminium – painted grey.

### 3 Installation

As with any radio communication system, the Modbus receiver should be connected to a clean and stable power supply. Both AC and DC power supplies can be used to power the receiver.

If using a switch mode power supply, be aware these types can be rich in harmonics that can cause the high gain receiver module to block the reception of data. The frequency of offending harmonics can shift with temperature, time and load.

For maximum transmission range the antenna of both the transmitter and receiver should point upward (vertical polarization) and should be kept clear of obstructions, particularly metallic surfaces.

As standard, an N-type helical antenna is supplied with the Modbus receiver, should an alternative be required contact the HWM Sales department for alternatives. Whatever antenna type is selected ensure the impedance is 50Ω.

#### 3.1 Location

For indoor installations, it is recommended that the receiver is located away from sources of heat and electrical apparatus such as inverters. Care should be taken to minimise cable lengths both with respect to the antenna location and the attached terminal equipment. Generally, RS232 should be used for short distance links <10m and RS485 for longer links <300m.

#### 3.2 LED Indication

A number of visual indicators are present on the PCB to provide some level of diagnostics.

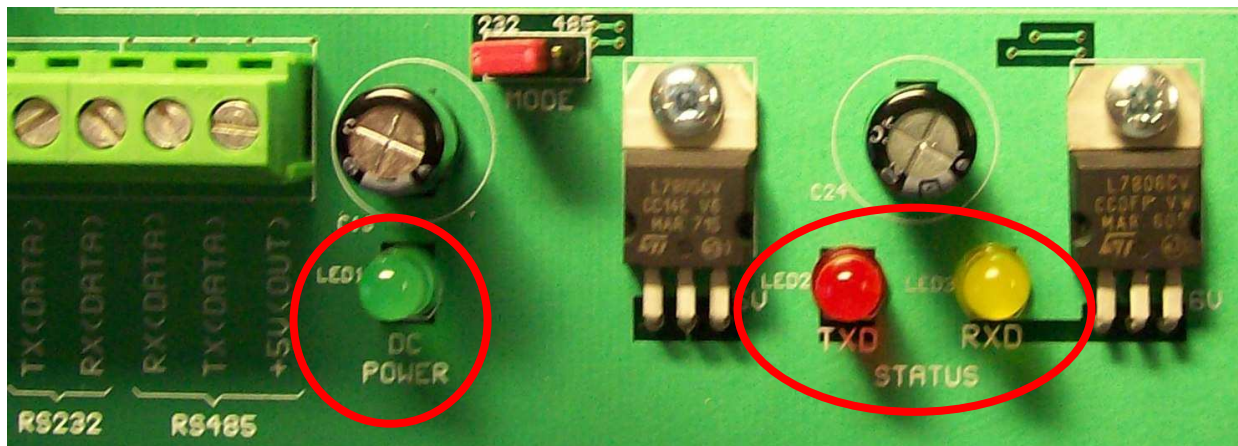

- DC Power: ON (Green) – Receiver has power
- TxD LED: ON (Red) – Sending data on communications port
- RxD. LED: ON (Amber) – Receiving data

## 4 Connections

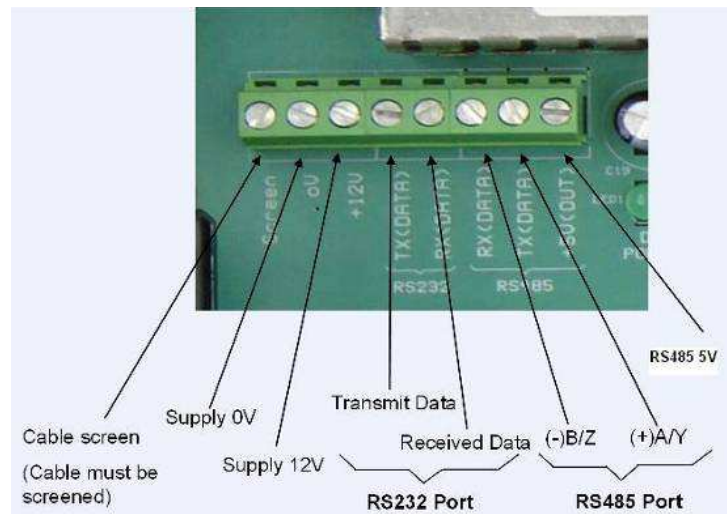

Data and power connections should always be made using screened cable. Using a screened cable will help to reject interference. You should always use a common ground point and avoid the formation of current loops.

Terminal	Description	Notes
Screen	Earth (Comms Cable Screen)	
0V	DC Power -ve	
+12V	DC Positive +ve	
TX(DATA)	RS232 Tx Output	
RX(DATA)	RS232 RX Input	
B/Z (-)	BZ - RS485 +ve	
A/Y (+)	AY - RS485 -ve	
+5V (OUT)	+5V Out	Can be used as pull-up for RS485 bus

**Note:** RS485 connections, it is the responsibility of the system builder to ensure that the connections are correctly terminated. Normally, cables with an impedance of greater than 100Ω should be used. Open ends may need terminating using 120Ω resistors between the **AY** and **BZ** terminals.



## 5 Configuration

### 5.1 Dip Switch Settings

SW1 – Receiver outputs Binary data

SW2 – Receiver outputs ASCII data

SW3 – Set data rate to 4800Baud (either SW3 or SW4 ON – do not set both to ON position).

SW4 – Set data rate to 9600Baud (either SW3 or SW4 ON – do not set both to ON position).

**Note:** Only select SW1 or SW2 to be ON for serial format, similarly with SW3 or SW4 for Baud-rate.

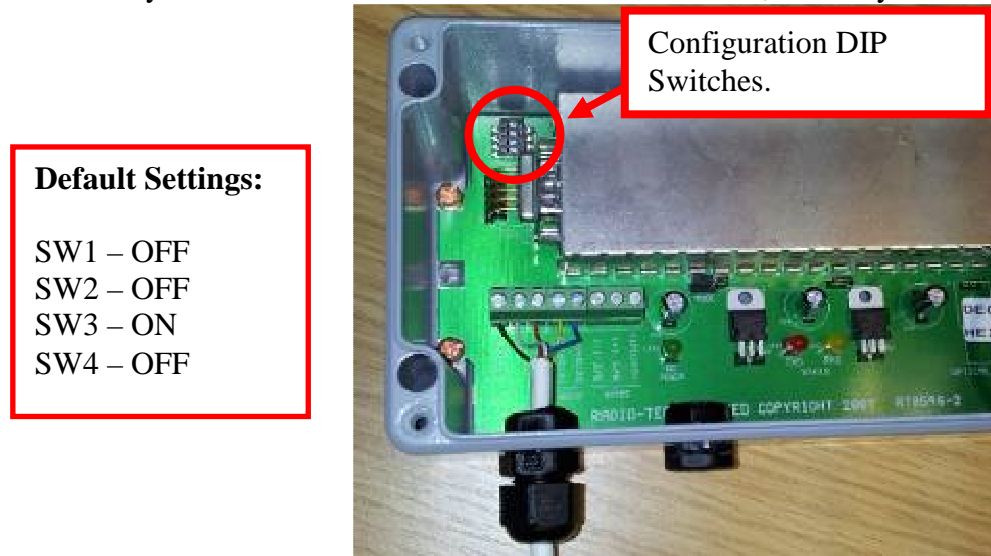

The communication mode selection jumper should set to either:

*Left + Middle* of header pins for RS232 mode.

Or *Middle + Right* of header pins for RS485 mode.



### 5.2 Programming

A simple programming application is available from HWM to program and validate the receiver. However, it is strongly recommended that this is built into the system.

The Modbus Receiver supports the Modbus remote terminal unit (RTU) Slave Mode. Only two standard function codes are supported (03<sub>dec</sub> & 16<sub>dec</sub>), an additional custom code (66<sub>dec</sub>) is used to program unit ID.

The receiver needs to be programmed with the addresses of all the transmitters expected to receive. A memory map is defined (*Appendix 1*) holding the transmitter IDs, status and data bytes. This data can be read back by the Modbus Master device.

## 5.3 Addressing Modes

### 5.3.1 8-Bit Addressing

The addresses of the transmitters need to be programmed into the memory map and read back with the data as verification. E.g. consider transmitter in memory slot 2:

No.	Reg DEC	Reg HEX	Description
2	792	0318	Transmitter Address HHO
2	793	0319	Transmitter Address HO
2	794	031A	Transmitter Address LO
2	795	031B	Transmitter Status
2	796	031C	Data 1
2	797	031D	Data 2
2	798	031E	Data 3
2	799	031F	Data 4

Registers 792-794<sub>dec</sub> (0x0318) hold the 24-bit transmitter address, so if data needs to be received from transmitter number 54322<sub>dec</sub> (00D432<sub>hex</sub>), the registers will need to be programmed with the value 00D432<sub>hex</sub>, 00<sub>hex</sub> into register 0x0318, D4<sub>hex</sub> into register 0x0319 and 32<sub>hex</sub> into register 0x031A

### 5.3.2 16-Bit Addressing (Extended Addressing Range)

No.	Reg DEC	Reg HEX	Description
2	4118	1016	Transmitter Address Hi 16bits
2	4119	1017	Transmitter Address Lo 16bits
2	4120	1018	0 Transmitter Status
2	4121	1019	0 Data 1
2	4122	101A	Data 2 Data 3
2	4123	101B	0 Data 4

Registers 4118 (0x1016) and 4119 (0x1017) hold the 24-bit transmitter address, so if data needs to be received from transmitter number 76322 (012A22<sub>hex</sub>), the registers will need to be programmed with the value 012A22<sub>hex</sub>, 0001<sub>hex</sub> into register 0x1016 and 2A22<sub>hex</sub> into register 0x1017.

When data is received from the transmitter, the rest of the registers will be filled with the data received. The transmitter status and data values vary in their content types depending on the transmitter type being received.

Modbus supports 8 to 16-bit formats and many of the values implemented on the AMR transmitters vary between 8 to 24-bits. The Modbus receiver has an 8-bit and 16-bit Modbus (v8 firmware) standards implemented.

When using the 8-bit standard every register has the first 8-bits set as 00. E.g.data value 1122867<sub>dec</sub> (112233<sub>hex</sub>) in Modbus communications would be broken up into 3 registers and sent as 0011<sub>hex</sub>, 0022<sub>hex</sub> and 0033<sub>hex</sub>.



## 5.4 Code Examples

Similarly, the host has to configure the addresses in the same way.  
Below are some example messages:

**Note:** When using 8-bit addressing mode all data is transmitted as an 8-bit value and Modbus reads registers as 16-bit (2 registers). Therefore the high register is always set as 00.

### 5.4.1 Code 66 – Program Unit ID

To configure the receiver with unit ID 1001<sub>hex</sub> using Modbus address 4

**00 42 10 01 04 31 EE** - all values are hexadecimal

where **0042** - Global Message Code 66

10 01 -16-bit Receiver Address

04 - Modbus Address (to be programmed into unit)

31 EE - CRC

To configure the receiver unit ID 1010 with a Modbus address 10

**00 42 10 10 0A BC 7A** - all values are hexadecimal

### 5.4.2 Code 03 – Read Holding Registers (8-Bit Addressing)

Read Ch1 – Ch8 from Modbus Slave 10

**0A 03 03 10 00 40 44 C0** - all values are hexadecimal

where 0A - Slave Address 10

03 - Modbus Function Code

03 10 - First Register to Read

00 40 - 64 Registers to Read (*Appendix I*)

44 C0 - CRC

Read Ch9 – Ch16 from Modbus Slave 10

**0A 03 03 50 00 40 45 14** - all values are hexadecimal

Read Ch17 – Ch24 from Modbus Slave 10

**0A 03 03 90 00 40 45 28** - all values are hexadecimal

Read Ch25 – Ch32 from Modbus Slave 10

**0A 03 03 C8 00 40 C4 FB** - all values are hexadecimal

### 5.4.3 Code 03 – Read Holding Registers (16-Bit Addressing)

Read Ch1 – Ch8 from Modbus Slave 10

**0A 03 10 10 00 30 44 C0** - all values are hexadecimal

where 0A - Slave address 10

03 - Modbus Function Code

10 10 - First Register to Read

00 30 - 48 Registers to read (*Appendix I*)

41 A0 - CRC

#### 5.4.4 Code 16 – Write Multiple Register (8-bit Addressing)

Write address 51234<sub>dec</sub> (00C822<sub>hex</sub>) into Ch1 location and clear all other locations- to Slave 4

**04 10 03 10 00 08 10 00 00 00 C8 00 22 00 00 00 00 00 00 00 00 00 35 93**

where

- 04 - Slave address 4
- 10 - Modbus Function Code 16
- 03 10 - First Register to Write to
- 00 08 - Number of Registers to Write to
- 10 - Number of bytes following (16)
- 00 00 00 C8 00 22 - address written into first 3 registers
- 00 00 - Register 4
- 00 00 - Register 5
- 00 00 - Register 6
- 00 00 - Register 7
- 00 00 - Register 8
- 35 93 - CRC

#### 5.4.5 Code 16 – Write Multiple Register (16-Bit Addressing)

Write address 51234<sub>dec</sub> (00C822<sub>hex</sub>) into Ch1 location and clear all other locations- to Slave 4

**04 10 10 10 00 05 0C 00 00 C8 22 00 00 00 00 00 00 00 00 00 00 35 93**

where

- 04 - Slave address 4
- 10 - Modbus Function Code 16
- 10 10 - First Register to Write to
- 00 05 - Number of Registers to Write to
- 0C - Number of Bytes Following (12)
- 00 00 - Transmitter Address Hi 16 bits
- C8 22 - Transmitter Address Lo 16 bits
- 00 00 - Register 3 (0, Transmitter Status)
- 00 00 - Register 4 (0,Data 1)
- 00 00 - Register 5 (Data 2,Data 3)
- 00 00 - Register 6 (0,Data 4)
- 35 93 - CRC

## 6 Transmitter Types

The firmware in Modbus receivers manufactured on and after May 2013 will have updated firmware. The update allows for all data types to be received and 16-bit mapping implemented.

Below is a description of the data packet breakdowns for popular types of transmitter. For a complete list of transmitter types please contact HWM.

### 6.1 Pulse Transmitter – Type 81

Transmitter Status	Bit 7 set for Low Battery. Bit 4 is Tamper (if available). Bits 0-3 is Firmware Revision.
Data 1 – Data 3	24-bit Pulse Count Value. For example, Value $234455_{\text{hex}} = 2311253_{\text{dec}}$
Data 4	Cumulative Counter that increments for each data transmission. High nibble is signal strength (between 0-10) for VHF transmitters. Low nibble is incremental counter (between 0-15).

### 6.2 Digital Temperature Transmitter – Type 82

Transmitter Status	Bit 7 set for Low Battery. Bits 0-3 is Firmware Revision.
Data 1 – Data 2	16-bit Temperature Channel 1. MSB set if Invalid Temperature. Temperature Value = value/2. Value Count Positive if Temperature > 0. Value Counts in Reverse if Temperature < 0. 0002 → 1.0°C 0001 → 0.5°C 0000 → 0°C 0FFF → -0.5°C 0FFE → -1.0°C

**Example:**

$8034_{\text{hex}} = \text{MSB set - Invalid Temperature}$

$0034_{\text{hex}} = 52_{\text{dec}}$  Temperature =  $52/2 = \underline{\underline{26.0^\circ\text{C}}}$

$0FC3_{\text{hex}} = 4035_{\text{dec}}$

Temperature =  $(4096-4035)/2 = \underline{\underline{-30.5^\circ\text{C}}}$

Data 3 : Not Used – Ignore.

Data 4 : Cumulative Counter that increments for each data transmission.

HO nibble is signal strength (between 0-10).

LO nibble is incremental counter (between 0-15).

### 6.3 Alarm/Status Transmitter – Type 88

Transmitter Status	Bit 7 set for Low Battery. Bit 5 is Contact Status Ch2. Bit 4 is Contact Status Ch1. Bits 0-3 is Firmware Revision.
Data 1 – Data 3	24-bit pulse count value. For example, value $234455_{\text{hex}} = 2311253_{\text{dec}}$
Data 4	Cumulative Counter that increments for each data transmission. High nibble is signal strength (between 0-10) for VHF transmitters. Low nibble is incremental counter (between 0-15).

# Appendix 1

## Memory Map (8-Bit Addressing)

Tx. No.	Modbus Register Address		Description
	Dec	Hex	
1	784	0310	Transmitter Address HHO
1	785	0311	Transmitter Address HO
1	786	0312	Transmitter Address LO
1	787	0313	Transmitter Status
1	788	0314	Data 1
1	789	0315	Data 2
1	790	0316	Data 3
1	791	0317	Data4
2	792	0318	Transmitter Address HHO
2	793	0319	Transmitter Address HO
2	794	031A	Transmitter Address LO
2	795	031B	Transmitter Status
2	796	031C	Data 1
2	797	031D	Data 2
2	798	031E	Data 3
2	799	031F	Data 4
3	800	0320	Transmitter Address HHO
3	801	0321	Transmitter Address HO
3	802	0322	Transmitter Address LO
3	803	0323	Transmitter Status
3	804	0324	Data 1
3	805	0325	Data 2
3	806	0326	Data 3
3	807	0327	Data4
4	808	0328	Transmitter Address HHO
4	809	0329	Transmitter Address HO
4	810	032A	Transmitter Address LO
4	811	032B	Transmitter Status
4	812	032C	Data 1
4	813	032D	Data 2
4	814	032E	Data 3
4	815	032F	Data 4
5	816	0330	Transmitter Address HHO
5	817	0331	Transmitter Address HO
5	818	0332	Transmitter Address LO
5	819	0333	Transmitter Status
5	820	0334	Data 1
5	821	0335	Data 2
5	822	0336	Data 3
5	823	0337	Data4
6	824	0338	Transmitter Address HHO
6	825	0339	Transmitter Address HO
6	826	033A	Transmitter Address LO
6	827	033B	Transmitter Status
6	828	033C	Data 1
6	829	033D	Data 2

6	830	033E	Data 3
6	831	033F	Data 4
7	832	0340	Transmitter Address HHO
7	833	0341	Transmitter Address HO
7	834	0342	Transmitter Address LO
7	835	0343	Transmitter Status
7	836	0344	Data 1
7	837	0345	Data 2
7	838	0346	Data 3
7	839	0347	Data4
8	840	0348	Transmitter Address HHO
8	841	0349	Transmitter Address HO
8	842	034A	Transmitter Address LO
8	843	034B	Transmitter Status
8	844	034C	Data 1
8	845	034D	Data 2
8	846	034E	Data 3
8	847	034F	Data 4
9	848	0350	Transmitter Address HHO
9	849	0351	Transmitter Address HO
9	850	0352	Transmitter Address LO
9	851	0353	Transmitter Status
9	852	0354	Data 1
9	853	0355	Data 2
9	854	0356	Data 3
9	855	0357	Data4
10	856	0358	Transmitter Address HHO
10	857	0359	Transmitter Address HO
10	858	035A	Transmitter Address LO
10	859	035B	Transmitter Status
10	860	035C	Data 1
10	861	035D	Data 2
10	862	035E	Data 3
10	863	035F	Data 4
11	864	0360	Transmitter Address HHO
11	865	0361	Transmitter Address HO
11	866	0362	Transmitter Address LO
11	867	0363	Transmitter Status
11	868	0364	Data 1
11	869	0365	Data 2
11	870	0366	Data 3
11	871	0367	Data4
12	872	0368	Transmitter Address HHO
12	873	0369	Transmitter Address HO
12	874	036A	Transmitter Address LO
12	875	036B	Transmitter Status
12	876	036C	Data 1
12	877	036D	Data 2
12	878	036E	Data 3
12	879	036F	Data 4
13	880	0370	Transmitter Address HHO
13	881	0371	Transmitter Address HO
13	882	0372	Transmitter Address LO
13	883	0373	Transmitter Status
13	884	0374	Data 1
13	885	0375	Data 2



13	886	0376	Data 3
13	887	0377	Data4
14	888	0378	Transmitter Address HHO
14	889	0379	Transmitter Address HO
14	890	037A	Transmitter Address LO
14	891	037B	Transmitter Status
14	892	037C	Data 1
14	893	037D	Data 2
14	894	037E	Data 3
14	895	037F	Data 4
15	896	0380	Transmitter Address HHO
15	897	0381	Transmitter Address HO
15	898	0382	Transmitter Address LO
15	899	0383	Transmitter Status
15	900	0384	Data 1
15	901	0385	Data 2
15	902	0386	Data 3
15	903	0387	Data4
16	904	0388	Transmitter Address HHO
16	905	0389	Transmitter Address HO
16	906	038A	Transmitter Address LO
16	907	038B	Transmitter Status
16	908	038C	Data 1
16	909	038D	Data 2
16	910	038E	Data 3
16	911	038F	Data 4
17	912	0390	Transmitter Address HHO
17	913	0391	Transmitter Address HO
17	914	0392	Transmitter Address LO
17	915	0393	Transmitter Status
17	916	0394	Data 1
17	917	0395	Data 2
17	918	0396	Data 3
17	919	0397	Data4
18	920	0398	Transmitter Address HHO
18	921	0399	Transmitter Address HO
18	922	039A	Transmitter Address LO
18	923	039B	Transmitter Status
18	924	039C	Data 1
18	925	039D	Data 2
18	926	039E	Data 3
18	927	039F	Data 4
19	928	03A0	Transmitter Address HHO
19	929	03A1	Transmitter Address HO
19	930	03A2	Transmitter Address LO
19	931	03A3	Transmitter Status
19	932	03A4	Data 1
19	933	03A5	Data 2
19	934	03A6	Data 3
19	935	03A7	Data4
20	936	03A8	Transmitter Address HHO
20	937	03A9	Transmitter Address HO
20	938	03AA	Transmitter Address LO
20	939	03AB	Transmitter Status
20	940	03AC	Data 1
20	941	03AD	Data 2

20	942	03AE	Data 3
20	943	03AF	Data 4
21	944	03B0	Transmitter Address HHO
21	945	03B1	Transmitter Address HO
21	946	03B2	Transmitter Address LO
21	947	03B3	Transmitter Status
21	948	03B4	Data 1
21	949	03B5	Data 2
21	950	03B6	Data 3
21	951	03B7	Data4
22	952	03B8	Transmitter Address HHO
22	953	03B9	Transmitter Address HO
22	954	03BA	Transmitter Address LO
22	955	03BB	Transmitter Status
22	956	03BC	Data 1
22	957	03BD	Data 2
22	958	03BE	Data 3
22	959	03BF	Data 4
23	960	03C0	Transmitter Address HHO
23	961	03C1	Transmitter Address HO
23	962	03C2	Transmitter Address LO
23	963	03C3	Transmitter Status
23	964	03C4	Data 1
23	965	03C5	Data 2
23	966	03C6	Data 3
23	967	03C7	Data4
24	968	03C8	Transmitter Address HHO
24	969	03C9	Transmitter Address HO
24	970	03CA	Transmitter Address LO
24	971	03CB	Transmitter Status
24	972	03CC	Data 1
24	973	03CD	Data 2
24	974	03CE	Data 3
24	975	03CF	Data 4
25	976	03D0	Transmitter Address HHO
25	977	03D1	Transmitter Address HO
25	978	03D2	Transmitter Address LO
25	979	03D3	Transmitter Status
25	980	03D4	Data 1
25	981	03D5	Data 2
25	982	03D6	Data 3
25	983	03D7	Data4
26	984	03D8	Transmitter Address HHO
26	985	03D9	Transmitter Address HO
26	986	03DA	Transmitter Address LO
26	987	03DB	Transmitter Status
26	988	03DC	Data 1
26	989	03DD	Data 2
26	990	03DE	Data 3
26	991	03DF	Data 4
27	992	03E0	Transmitter Address HHO
27	993	03E1	Transmitter Address HO
27	994	03E2	Transmitter Address LO
27	995	03E3	Transmitter Status
27	996	03E4	Data 1
27	997	03E5	Data 2

27	998	03E6	Data 3
27	999	03E7	Data4
28	1000	03E8	Transmitter Address HHO
28	1001	03E9	Transmitter Address HO
28	1002	03EA	Transmitter Address LO
28	1003	03EB	Transmitter Status
28	1004	03EC	Data 1
28	1005	03ED	Data 2
28	1006	03EE	Data 3
28	1007	03EF	Data 4
29	1008	03F0	Transmitter Address HHO
29	1009	03F1	Transmitter Address HO
29	1010	03F2	Transmitter Address LO
29	1011	03F3	Transmitter Status
29	1012	03F4	Data 1
29	1013	03F5	Data 2
29	1014	03F6	Data 3
29	1015	03F7	Data4
30	1016	03F8	Transmitter Address HHO
30	1017	03F9	Transmitter Address HO
30	1018	03FA	Transmitter Address LO
30	1019	03FB	Transmitter Status
30	1020	03FC	Data 1
30	1021	03FD	Data 2
30	1022	03FE	Data 3
30	1023	03FF	Data 4
31	1024	0400	Transmitter Address HHO
31	1025	0401	Transmitter Address HO
31	1026	0402	Transmitter Address LO
31	1027	0403	Transmitter Status
31	1028	0404	Data 1
31	1029	0405	Data 2
31	1030	0406	Data 3
31	1031	0407	Data4
32	1032	0408	Transmitter Address HHO
32	1033	0409	Transmitter Address HO
32	1034	040A	Transmitter Address LO
32	1035	040B	Transmitter Status
32	1036	040C	Data 1
32	1037	040D	Data 2
32	1038	040E	Data 3
32	1039	040F	Data 4

The transmitter address and data values are 24-bit, Modbus works with 16-bit registers, all the above registers are sent as 16-bit addresses. The high byte will always be 00, for example: for a pulse count of 34562<sub>dec</sub> (008702<sub>hex</sub>), will be sent as 0x0000, 0x0087 & 0x0002 for Data 1, Data 2 and Data 3.

## Memory Map (16-Bit Addressing)

**Note:** 16-bit addressing mode is only available on firmware version V8.00 and above. The Following table details the extended register map used for 16-bit addressing mode.

Tx. No.	Modbus Register Address		Description	
	Dec	Hex	High byte	Low byte
N/A	4096	1000	Firmware ID	
N/A	4097	1001	Firmware Version	
N/A	4098	1002	Frequency band	
1	4112	1010	Transmitter Address Hi 16bits	
1	4113	1011	Transmitter Address Lo 16bits	
1	4114	1012	0	Transmitter Status
1	4115	1013	0	Data 1
1	4116	1014	Data 2	Data 3
1	4117	1015	0	Data 4
2	4118	1016	Transmitter Address Hi 16bits	
2	4119	1017	Transmitter Address Lo 16bits	
2	4120	1018	0	Transmitter Status
2	4121	1019	0	Data 1
2	4122	101A	Data 2	Data 3
2	4123	101B	0	Data 4
3	4124	101C	Transmitter Address Hi 16bits	
3	4125	101D	Transmitter Address Lo 16bits	
3	4126	101E	0	Transmitter Status
3	4127	101F	0	Data 1
3	4128	1020	Data 2	Data 3
3	4129	1021	0	Data 4
4	4130	1022	Transmitter Address Hi 16bits	
4	4131	1023	Transmitter Address Lo 16bits	
4	4132	1024	0	Transmitter Status
4	4133	1025	0	Data 1
4	4134	1026	Data 2	Data 3
4	4135	1027	0	Data 4
5	4136	1028	Transmitter Address Hi 16bits	
5	4137	1029	Transmitter Address Lo 16bits	
5	4138	102A	0	Transmitter Status
5	4139	102B	0	Data 1
5	4140	102C	Data 2	Data 3
5	4141	102D	0	Data 4
6	4142	102E	Transmitter Address Hi 16bits	
6	4143	102F	Transmitter Address Lo 16bits	
6	4144	1030	0	Transmitter Status
6	4145	1031	0	Data 1
6	4146	1032	Data 2	Data 3
6	4147	1033	0	Data 4
7	4148	1034	Transmitter Address Hi 16bits	
7	4149	1035	Transmitter Address Lo 16bits	
7	4150	1036	0	Transmitter Status
7	4151	1037	0	Data 1
7	4152	1038	Data 2	Data 3
7	4153	1039	0	Data 4
8	4154	103A	Transmitter Address Hi 16bits	

8	4155	103B	Transmitter Address Lo 16bits	
8	4156	103C	0	Transmitter Status
8	4157	103D	0	Data 1
8	4158	103E	Data 2	Data 3
8	4159	103F	0	Data 4
9	4160	1040	Transmitter Address Hi 16bits	
9	4161	1041	Transmitter Address Lo 16bits	
9	4162	1042	0	Transmitter Status
9	4163	1043	0	Data 1
9	4164	1044	Data 2	Data 3
9	4165	1045	0	Data 4
10	4166	1046	Transmitter Address Hi 16bits	
10	4167	1047	Transmitter Address Lo 16bits	
10	4168	1048	0	Transmitter Status
10	4169	1049	0	Data 1
10	4170	104A	Data 2	Data 3
10	4171	104B	0	Data 4
11	4172	104C	Transmitter Address Hi 16bits	
11	4173	104D	Transmitter Address Lo 16bits	
11	4174	104E	0	Transmitter Status
11	4175	104F	0	Data 1
11	4176	1050	Data 2	Data 3
11	4177	1051	0	Data 4
12	4178	1052	Transmitter Address Hi 16bits	
12	4179	1053	Transmitter Address Lo 16bits	
12	4180	1054	0	Transmitter Status
12	4181	1055	0	Data 1
12	4182	1056	Data 2	Data 3
12	4183	1057	0	Data 4
13	4184	1058	Transmitter Address Hi 16bits	
13	4185	1059	Transmitter Address Lo 16bits	
13	4186	105A	0	Transmitter Status
13	4187	105B	0	Data 1
13	4188	105C	Data 2	Data 3
13	4189	105D	0	Data 4
14	4190	105E	Transmitter Address Hi 16bits	
14	4191	105F	Transmitter Address Lo 16bits	
14	4192	1060	0	Transmitter Status
14	4193	1061	0	Data 1
14	4194	1062	Data 2	Data 3
14	4195	1063	0	Data 4
15	4196	1064	Transmitter Address Hi 16bits	
15	4197	1065	Transmitter Address Lo 16bits	
15	4198	1066	0	Transmitter Status
15	4199	1067	0	Data 1
15	4200	1068	Data 2	Data 3
15	4201	1069	0	Data 4
16	4202	106A	Transmitter Address Hi 16bits	
16	4203	106B	Transmitter Address Lo 16bits	
16	4204	106C	0	Transmitter Status
16	4205	106D	0	Data 1
16	4206	106E	Data 2	Data 3
16	4207	106F	0	Data 4
17	4208	1070	Transmitter Address Hi 16bits	
17	4209	1071	Transmitter Address Lo 16bits	
17	4210	1072	0	Transmitter Status

17	4211	1073	0	Data 1
17	4212	1074	Data 2	Data 3
17	4213	1075	0	Data 4
18	4214	1076	Transmitter Address Hi 16bits	
18	4215	1077	Transmitter Address Lo 16bits	
18	4216	1078	0	Transmitter Status
18	4217	1079	0	Data 1
18	4218	107A	Data 2	Data 3
18	4219	107B	0	Data 4
19	4220	107C	Transmitter Address Hi 16bits	
19	4221	107D	Transmitter Address Lo 16bits	
19	4222	107E	0	Transmitter Status
19	4223	107F	0	Data 1
19	4224	1080	Data 2	Data 3
19	4225	1081	0	Data 4
20	4226	1082	Transmitter Address Hi 16bits	
20	4227	1083	Transmitter Address Lo 16bits	
20	4228	1084	0	Transmitter Status
20	4229	1085	0	Data 1
20	4230	1086	Data 2	Data 3
20	4231	1087	0	Data 4
21	4232	1088	Transmitter Address Hi 16bits	
21	4233	1089	Transmitter Address Lo 16bits	
21	4234	108A	0	Transmitter Status
21	4235	108B	0	Data 1
21	4236	108C	Data 2	Data 3
21	4237	108D	0	Data 4
22	4238	108E	Transmitter Address Hi 16bits	
22	4239	108F	Transmitter Address Lo 16bits	
22	4240	1090	0	Transmitter Status
22	4241	1091	0	Data 1
22	4242	1092	Data 2	Data 3
22	4243	1093	0	Data 4
23	4244	1094	Transmitter Address Hi 16bits	
23	4245	1095	Transmitter Address Lo 16bits	
23	4246	1096	0	Transmitter Status
23	4247	1097	0	Data 1
23	4248	1098	Data 2	Data 3
23	4249	1099	0	Data 4
24	4250	109A	Transmitter Address Hi 16bits	
24	4251	109B	Transmitter Address Lo 16bits	
24	4252	109C	0	Transmitter Status
24	4253	109D	0	Data 1
24	4254	109E	Data 2	Data 3
24	4255	109F	0	Data 4
25	4256	10A0	Transmitter Address Hi 16bits	
25	4257	10A1	Transmitter Address Lo 16bits	
25	4258	10A2	0	Transmitter Status
25	4259	10A3	0	Data 1
25	4260	10A4	Data 2	Data 3
25	4261	10A5	0	Data 4
26	4262	10A6	Transmitter Address Hi 16bits	
26	4263	10A7	Transmitter Address Lo 16bits	
26	4264	10A8	0	Transmitter Status
26	4265	10A9	0	Data 1
26	4266	10AA	Data 2	Data 3



26	4267	10AB	0	Data 4
27	4268	10AC	Transmitter Address Hi 16bits	
27	4269	10AD	Transmitter Address Lo 16bits	
27	4270	10AE	0	Transmitter Status
27	4271	10AF	0	Data 1
27	4272	10B0	Data 2	Data 3
27	4273	10B1	0	Data 4
28	4274	10B2	Transmitter Address Hi 16bits	
28	4275	10B3	Transmitter Address Lo 16bits	
28	4276	10B4	0	Transmitter Status
28	4277	10B5	0	Data 1
28	4278	10B6	Data 2	Data 3
28	4279	10B7	0	Data 4
29	4280	10B8	Transmitter Address Hi 16bits	
29	4281	10B9	Transmitter Address Lo 16bits	
29	4282	10BA	0	Transmitter Status
29	4283	10BB	0	Data 1
29	4284	10BC	Data 2	Data 3
29	4285	10BD	0	Data 4
30	4286	10BE	Transmitter Address Hi 16bits	
30	4287	10BF	Transmitter Address Lo 16bits	
30	4288	10C0	0	Transmitter Status
30	4289	10C1	0	Data 1
30	4290	10C2	Data 2	Data 3
30	4291	10C3	0	Data 4
31	4292	10C4	Transmitter Address Hi 16bits	
31	4293	10C5	Transmitter Address Lo 16bits	
31	4294	10C6	0	Transmitter Status
31	4295	10C7	0	Data 1
31	4296	10C8	Data 2	Data 3
31	4297	10C9	0	Data 4
32	4298	10CA	Transmitter Address Hi 16bits	
32	4299	10CB	Transmitter Address Lo 16bits	
32	4300	10CC	0	Transmitter Status
32	4301	10CD	0	Data 1
32	4302	10CE	Data 2	Data 3
32	4303	10CF	0	Data 4

**Note:** All the above registers are sent as 16 bit data with the high byte sent first (Big Endian), e.g. for a pulse count of 34562<sub>dec</sub> (8702<sub>hex</sub>), will be sent as 0x87 & 0x02.

## Appendix 2

### Modbus CRC Algorithm

A CRC-16 checksum is implemented on every message to detect any bit errors in the message. The checksum calculation is only used to detect errors but cannot correct them. The CRC is transmitted low byte first (Little Endian).

The CRC generating polynomial used is:  $x^{16} + x^{15} + x^2 + 1$

#### Visual Basic CRC Routine:

```
CRC Algorithm
Function Tcrcgen()

    Hicrc = &HFF
    Locrc = &HFF

    'Put data received into array
    For i% = 1 To Len(Outstring)
        Outarray(i%) = Mid$(Outstring, i%, 1)

        Hicrc = Hicrc Xor Asc(Outarray(i%))

    For Q = 1 To 8
        Carry = Hicrc And &H1

        'Below is Hicrc=((Hicrc shr 1)&$7F) OR ((Locrc & $01) shl 7)
        Hicrc = Hicrc / 2
        If (Locrc AND &H1) <> 0 Then
            Hicrc = Hicrc Or &H80
        End If

        'Below is Locrc=(Locrc shr 1) and $7Fh
        Locrc = Locrc / 2

        If Carry <> 0 Then
            Locrc = Locrc Xor &HA0
            Hicrc = Hicrc Xor &H1
        End If

    Next Q%
    Next i%

End Function
```