

# CD3200 THYRISTOR UNIT

from 15A to 110A

---



## CD Automation S.r.l.

Via Picasso 34/36 - 20025 - Legnano (MI) - ITALY

Tel +39 0331 577479 - Fax +39 0331 579479

E-Mail: [info@cdautomation.com](mailto:info@cdautomation.com) - WEB: [www.cdautomation.com](http://www.cdautomation.com)



# SUMMARY

<b>1 Important warnings for safety</b> .....	<b>5</b>
<b>2 Introduction</b> .....	<b>7</b>
2.1 Advantages compared with analog thyristor unit	7
2.2 CD-KP	8
2.3 CD-EASY	8
2.4 Software Configurator	9
<b>3 Quick Start</b> .....	<b>10</b>
<b>4 CD3200 Sizing</b> .....	<b>10</b>
<b>5 Identification and Order Code</b> .....	<b>11</b>
5.1 Identification of the unit	11
5.2 Order Code	12
<b>6 Installation</b> .....	<b>13</b>
6.1 Environmental installation conditions	13
6.2 Dimensions and Weight	14
6.3 CT dimensions	14
6.4 Fixing holes	15
<b>7 Wiring instructions</b> .....	<b>16</b>
7.1 Removing the cover	16
7.2 Wiring details	17
7.3 Power Terminals	18
7.4 Command Terminals	18
7.5 Diagram of control connection from size 15A to 25A	19
7.6 Diagram of control connection from size 35A to 45A	20
7.7 Diagram of control connection from size 60A to 110A	21
<b>8 Power output features</b> .....	<b>22</b>
8.1 Derating curve	22
8.2 Cooling fans	22
<b>9 Led status and Alarms</b> .....	<b>23</b>
9.1 LED Status Table	23
9.2 Not Critical Alarm	23
9.3 Calibration Procedure	24
<b>10 Firing type</b> .....	<b>24</b>
10.1 Phase Angle (PA)	25
10.2 Soft Start with Phase Angle (S+PA)	25
10.3 Action of the Limit Current	26
10.4 Feed-back type	27

<b>11 Connection description .....</b>	<b>28</b>
11.1 Access to the Electronic boards	28
11.2 Supply the Electronic Board	29
11.3 Analog Inputs	30
11.4 Digital Input	32
11.5 Digital Output	34
11.6 PG Connector	35
11.7 RS485 Serial Port	35
11.8 Address configuration	36
<b>12 MODBUS communication .....</b>	<b>37</b>
12.1 MODBUS RTU Protocol	37
12.2 Message Format	37
12.3 Read Holding Registers	39
12.4 Preset Multiple Registers	39
12.5 Error and exception responses	40
<b>13 Configuration Parameters .....</b>	<b>41</b>
<b>14 FuseHolder and Fuses .....</b>	<b>44</b>
14.1 FuseHolder size	44
14.2 Fuses and Fuse Code for UL	45
14.3 Fuses and Fuse Code for CE	46
<b>15 Maintenance .....</b>	<b>47</b>
15.1 Trouble Shooting	47
15.2 Fans	48
15.3 Maintenance	48
15.4 Repairing procedure	48
15.5 Warranty condition	48
<b>16 Note .....</b>	<b>49</b>

# 1 Important warnings for safety

This chapter contains important information for the safety. The not observance of these instructions may result in serious personal injury or death and can cause serious damages to the Thyristor unit and to the components system included.

The installation should be performed by qualified persons.



The Thyristor unit are integral part of industrial equipments. When it is supply, the Thyristor unit is subject to dangerous tensions.

- Don't remove the protection Cover.
- Don't use these unit in aerospace applications and/ or nuclear.



The nominal current corresponds to use at temperature not superior to 40°C.

- The Thyristor unit must be mounted in vertical position and without obstruction above and below to allow a good flow ventilation.
- The hot air of one thyristor unit must not invest the unit positioned above.
- For side by side placed leave a space of 15mm between the unit.



A suitable device must ensure that the unit can be electrically isolated from the supply, this allows the qualified people to work in safety.



## **Protection (Protection, Protezione)**

The unit have IP20 protection rating as defined by the specific international. Is necessary consider the place of installation.



## **Earth (Terre, Messa a terra)**

For safety, the Thyristor unit with isolated heat-sink must be connected to earth. Earth impedance should be correspondent to local earth regulation. Periodically the earth efficiency should be inspected.



## **Electronic supply (Alimentation électronique, Alimentazione elettronica)**

The electronic circuit of the Thyristor unit must be supplied by dedicated voltage for all electronic circuits and not in parallel with coil contactors, solenoids and other.

It's recommended to use a shielded transformer.



## **Electric Shock Hazard (Risque de choque électrique, Rischi di scosse elettriche)**

When the Thyristor unit is energized, after the power supply is shut off, wait least a minute for allow the discharge of the internal capacitors where there is a dangerous tension. Before working, make sure that:

- Only authorized personnel must perform maintenance, inspection, and replacement operations.
- The authorized personnel must read this manual before to have access to the unit.
- Unqualified People don't perform jobs on the same unit or in the immediate vicinities.

**Important warnings (Attention, Avvertenze importanti)**

During the operations with units under tension, local regulations regarding electrical installation should be rigidly observed:

- Respect the internal safety rules.
- Don't bend components to maintain insulation distances.
- Protect the units from high temperature humidity and vibrations.
- Don't touch components to prevent electrostatic discharges on them.
- Verify that the size is in line with real needs.
- To measure voltage current etc. on unit, remove rings and other jewels from fingers and hands.
- Authorized personnel that work on thyristor unit under power supply voltage must be on insulated board

This listing does not represent a complete enumeration of all necessary safety cautions.

**Electromagnetic compatibility****(Compatibilità elettromagnétique, Compatibilità elettromagnetica)**

Our thyristor units have an excellent immunity to electromagnetic interferences if all suggestions contained in this manual are respected. In respect to a good Engineering practice, all inductive loads like solenoids contactor coils should have a filter in parallel.

**Emissions (Emission, Emissioni)**

All solid-state power controllers emit a certain amount of radio-frequency energy because of the fast switching of the power devices.

The CD Automation's Thyristor unit are in accord with the EMC norms, CE mark.

In most installations, near by electronic systems will experience no difficulty with interference. If very sensitive electronic measuring equipment or low-frequency radio receivers are to be used near the unit, some special precautions may be required. These may include the installation of a line supply filter and the use of screened (shielded) output cable to the load.

**Note**

**Warning:** This icon is present in all the operational procedures where the Improper operation may result in serious personal injury or death



**Caution:** This icon is present in all the operational procedures where the Improper operation can cause damage for the Thyristor unit.

CD Automation reserves the right to modify the own products and this manual without any advise.



## 2 Introduction

A thyristor unit is semiconductor device which acts as a switch formed by two thyristors in ant parallel. To switch on the alternating current the input signal will be on and the thyristor will switch off at first Zero Crossing voltage with no input signal.

The benefits of thyristor units compared with elettromechanical contactors are numerous: no moving parts, no maintenance and capacity to switch very fast. Thyristors are the only solution to control transformers and special loads that change resistance with temperature and with age.

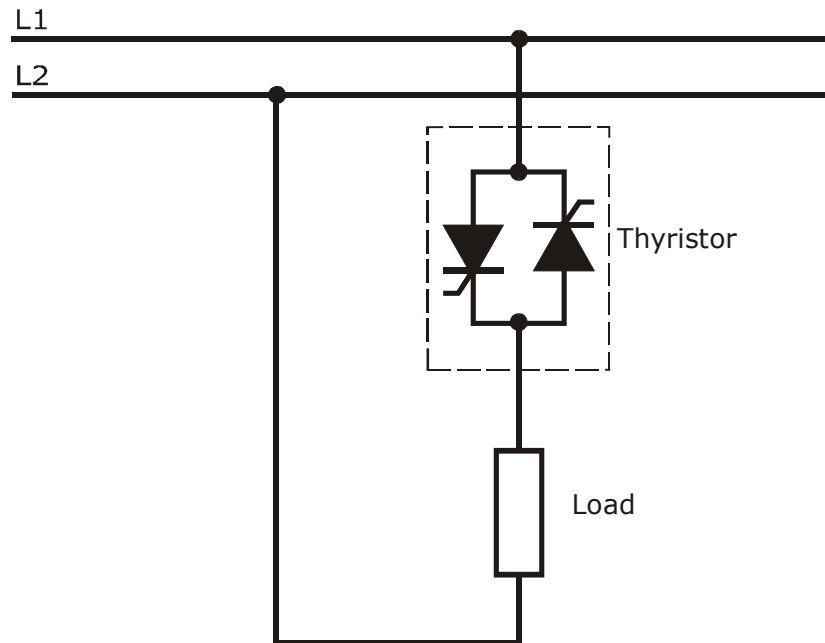

### 2.1 Advantages compared with analog thyristor unit

Communication RS485 is a standard feature of CD3200 this allows the use of many information like: current, power, load state and all the parameters for diagnostic and configuration. Ulterior advantages of the digital system vs the analogical is the flexibility and the possibility of implement special characteristics without change the hardware. Several strategies can be implemented and selected through the configuration parameters.

With CD-KP, you can have access to the configuration parameters without expose at the dangerous voltage inside the cabinet and without stop the plant.

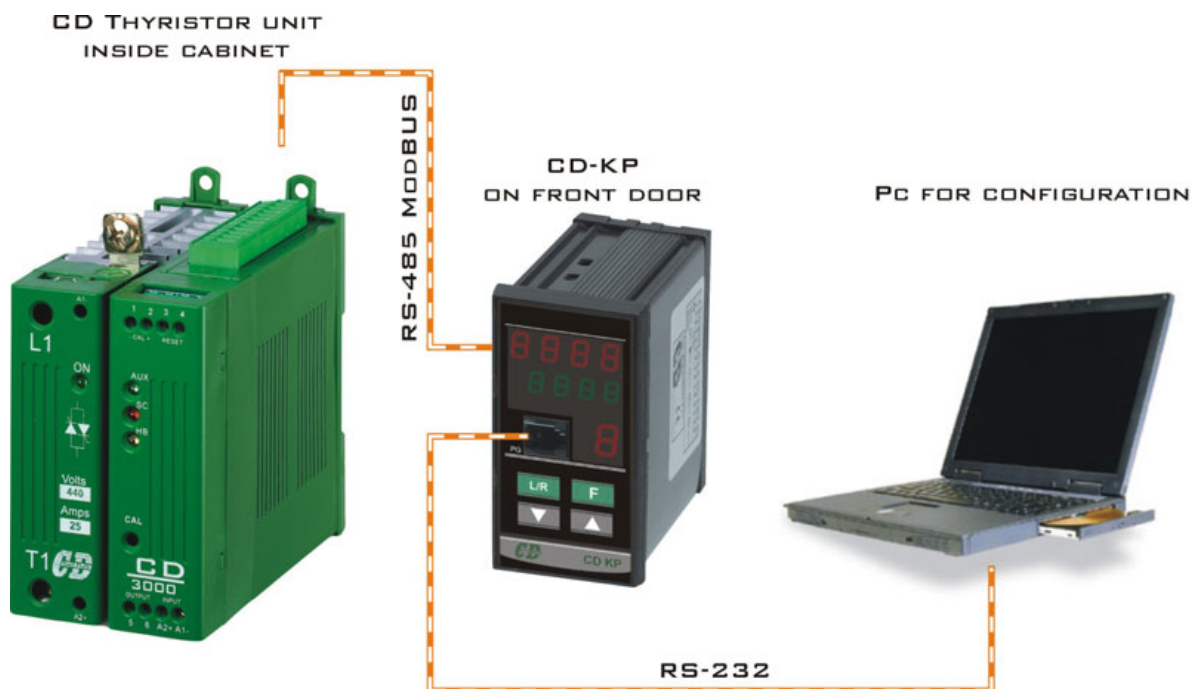

## 2.2 CD-KP

The CD-KP is designed to be connected with all CD Automation's Thyristor units via RS485 communication. On front unit is possible to read the principal operational parameters of the unit like: power, tension, current, reference, alarms, etc.

One of these variables can be selected and retransmitted via an isolated output (4÷20mA or 0÷10V) All the menus (except the operator menu) can be protected by password to avoid accidental change of configuration parameters by unauthorised personnel.

On front unit is also available a plug-in connector RS485 for connect a PC with the Thyristor units without open the cabinet and without stop the production process.

### Technical Specification:

- Use in Local/Remote
- Set Point Ramp UP - Down
- Scroll selection of:
  - Set point
  - Power output
  - Current
  - Voltage
- Display indication for:
  - Heater Break alarm
  - SCR short circuit
- Password for configuration parameters
- Plug-in connector on front to use software configurator
- Retransmission (4-20mA or 0-10Vdc) of one of these parameters: Power PV, Current, Voltage.
- Dimension 48x96x92mm (LxAxP)
- Comply with EMC, CE marked



## 2.3 CD-EASY

CD-EASY is a Memory of support used for maintenance people that is not confident in personal computer.

With the CD-EASY is possible memorize the configuration of one Thyristor Unit and paste it into another in few seconds.

CD-EASY could be loaded with the personal configuration of the unit and stored together with the system drawings in a convenient place, enabling unit reconfiguration within seconds if require.

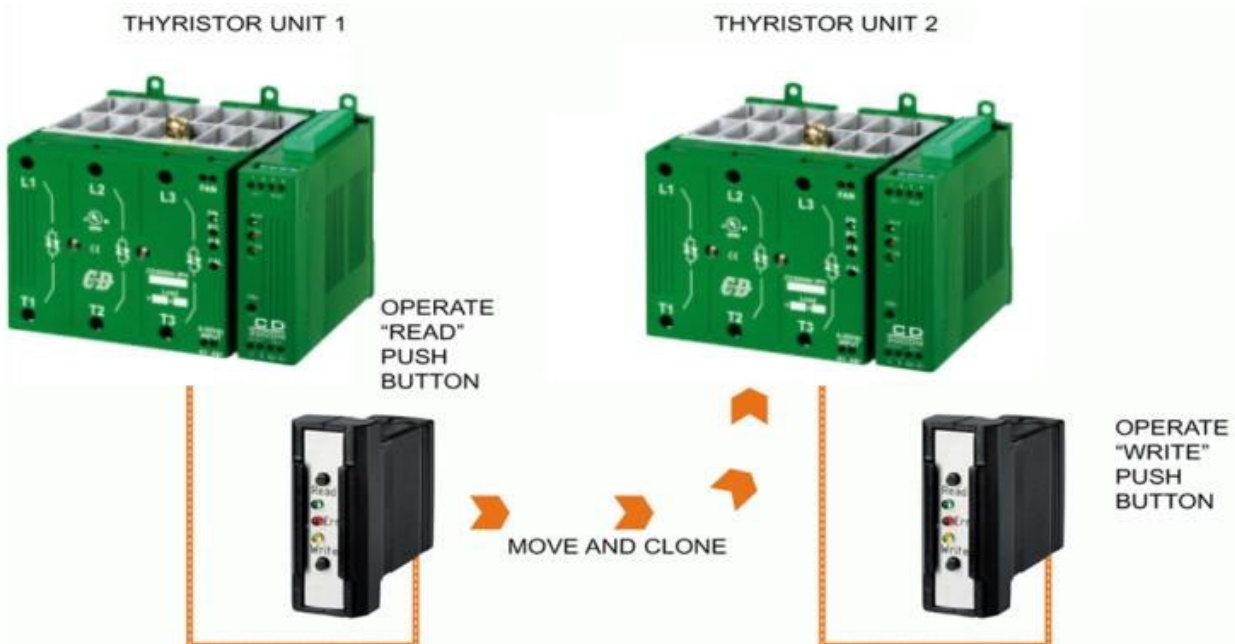



## 2.4 Software Configurator

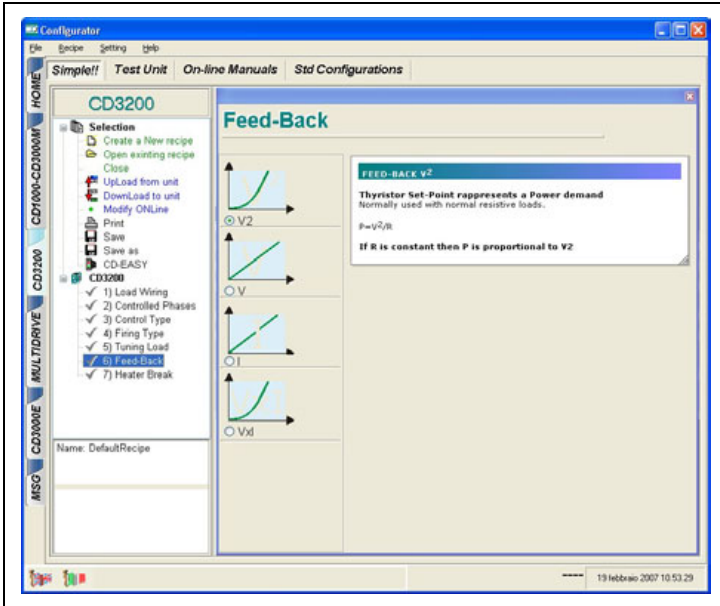

The software configuration is free and is possible download it from our site: [www.cdautomation.com](http://www.cdautomation.com)

If the Order Code is in line with requirement, then CD3200 has been already configured in Factory and it's ready to use. You need the software only to modify the ordered configuration. Anyway we suggest to check the unit on the machine with the "Test unit" section.

For install the software, launch the program and follow the instructions on the screen.



To connect the unit at the PC, it's necessary use the programming cable connected between the PG connector (see par. 11.6) and the serial port RS232 of the PC.

The programming cable is not included.



With the CD-RS serial converter is possible configure the Thyristor unit also through the RS485 (see par. 11.7). For this solution, the programming cable is not necessary.

Run the software configurator and set the serial port of the PC with con baudrate =9600 and the address of Thyristor unit (default=1).

## 3 Quick Start



**Caution:** this procedure must be performed only by qualified persons.

If the Order Code of the Thyristor unit is in line with what you really need, then CD3200 has been already configured in Factory and you just need to do the following steps:

1. Verify the CD3200 Sizing. Making sure that:
  - The load current is equal or less than the MAX current of CD3200.
  - The load voltage is equal or less than the MAX voltage of CD3200.
 (see par. 4)
2. Verify the Order Code  
(see par. 5.2)
3. Verify the Installation  
(see par. 6)
4. Verify the Diagram of control connection:
  - All auxiliary connections must be done in line with wirings on this manual.
  - Verify that there isn't a short circuit on the load.
  - Verify that the Reset Contact on terminal 3 and 4 are closed.
  - With External Enable option give Enable to the unit.
 (see par. 7.5)
5. Supply the Electronic boards  
(see Order Code)
6. Supply the Fan at 230VAC  $\pm 15\%$  50/60Hz (110VAC  $\pm 15\%$  50/60Hz Optional)  
(only for size S8C)
7. Supply the Power unit  
(see par. 7.3)
8. Make the Calibration procedure  
(see par. 9.3)

**The CD3200 Thyristor unit is ready to start.**

## 4 CD3200 Sizing

### 4.1.1 Wiring with resistive load

$$I = \frac{P}{V}$$

V = Nominal voltage phase to phase

I = Nominal current to the load

P = Nominal power to the load

### 4.1.2 Wiring with inductive load

$$I = \frac{P}{V \cos \phi}$$

V = Nominal voltage phase to phase

I = Nominal current to the load

P = Nominal power to the load

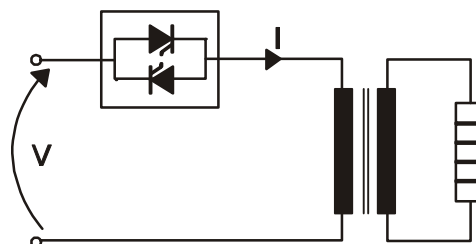
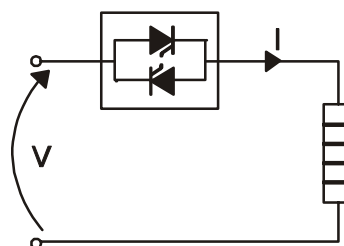

## 5 Identification and Order Code

### 5.1 Identification of the unit



**Caution:** Before to install, make sure that the Thyristor unit have not damages. If the product has a fault, please contact the dealer from which you purchased the product.

The identification's label give all the information regarding the factory settings of the Thyristor unit, this label is on the unit, like represented in figure.

Verify that the product is the same thing as ordered (see par. 5.2).



## 5.2 Order Code

<b>Model</b>	<b>1</b>	<b>2</b>	<b>3</b>	<b>4</b>	<b>5</b>	<b>6</b>	<b>7</b>	<b>8</b>	<b>9</b>
CD3200									

<b>1</b>	<b>Max Current of CD3200</b>								
	15A		35A		60A		110A		
	25A		45A		90A				
The Max Current must be equal or more than Load Current									

<b>2</b>	<b>Load Current</b>								
Specify this value to configure the unit in CD Automation									

<b>3</b>	<b>Load Voltage</b>								
Specify this value to configure the unit in CD Automation									

<b>4</b>	<b>Max Voltage of CD3200</b>								
	480V								
	600V								
The Max Voltage must be equal or more than Load Voltage									

<b>5</b>	<b>Auxiliary Voltage (Voltage supply for the Electronic boards)</b>								
	90:130	From 90 to 130Vac; 10VA							
	170:265	From 170 to 265Vac; 10VA							
	230:345	From 230 to 345Vac; 10VA							
	300:530	From 300 to 530Vac; 10VA							
	510:690	From 510 to 690Vac; 10VA							

<b>6</b>	<b>Input</b>								
	0÷10V	0÷10Vdc							
	4÷20mA	4÷20mA							
	POT	Potentiometer 10KΩ							

<b>7</b>	<b>Firing Type</b>								
	S+PA	Soft Start + Phase Angle							
	PA	Phase Angle							

<b>8</b>	<b>Feed Back</b>								
	V	Voltage							
	I	Current							
	V2	Voltage square							
	VxI	Power (VxI)							

<b>9</b>	<b>Option</b>								
	NCL	No current limit							
	CLP	External current limit profiling (0÷10Vdc)							
	EN	Opto isolated external enable							
	FBS	Opto isolated Feed-back Selection							
	EF	External fuses and fuse holders							
	NF	No fuses							
	HB	Heater Break Alarm							
	CD-KP	External Keypad							
	110Fan	Fan voltage supply 110VAC ± 15% (std 230VAC ± 15%) 50/60Hz							
	EP	External Protection IP20 for size S7C and S8C							
	UL	UL Certification							

## 6 Installation



**Caution:** Don't install near the hot elements or near the units that could give electromagnetic interferences.

The CD3200 Thyristor unit must be always mounted in vertical position to improve air cooling on heat-sink. Maintain the minimum distances in vertical and in horizontal as represented.

When more unit has mounted inside the cabinet maintain the air circulation like represented in figure. Sometimes is necessary installing a fan to have better air circulation.

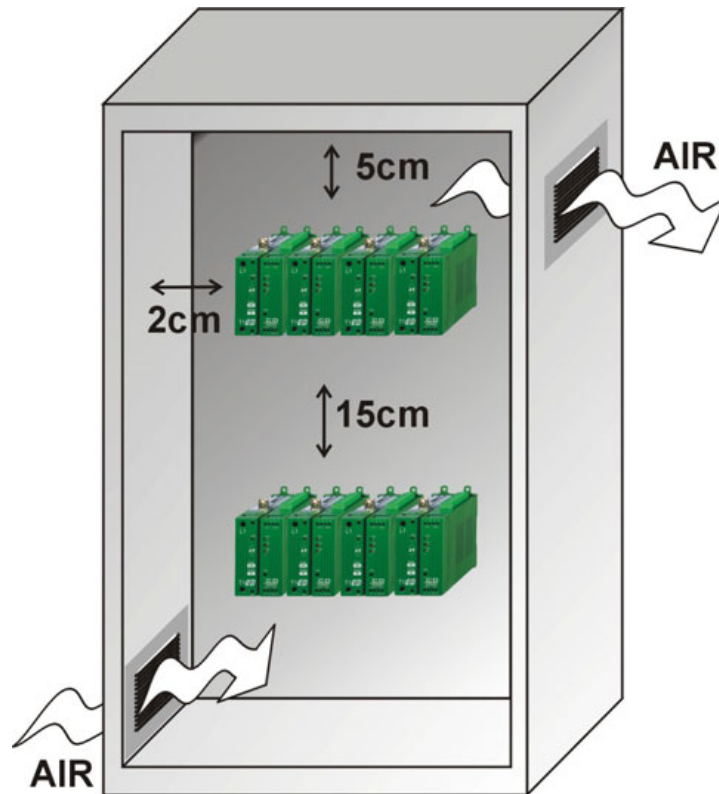

### 6.1 Environmental installation conditions

Ambient temperature	0-40°C at nominal current. Over 40°C use the derating curve (see par. 8.1)
Storage temperature	-25°C to 70°C
Installation place	Don't install at direct sun light, where there are conductive dust, corrosive gas, vibration or water and also in salty environmental.
Altitude	Up to 1000 meter over sea level. For higher altitude reduce the nominal current of 2% for each 100m over 1000m
Humidity	From 5 to 95% without condense and ice

## 6.2 Dimensions and Weight

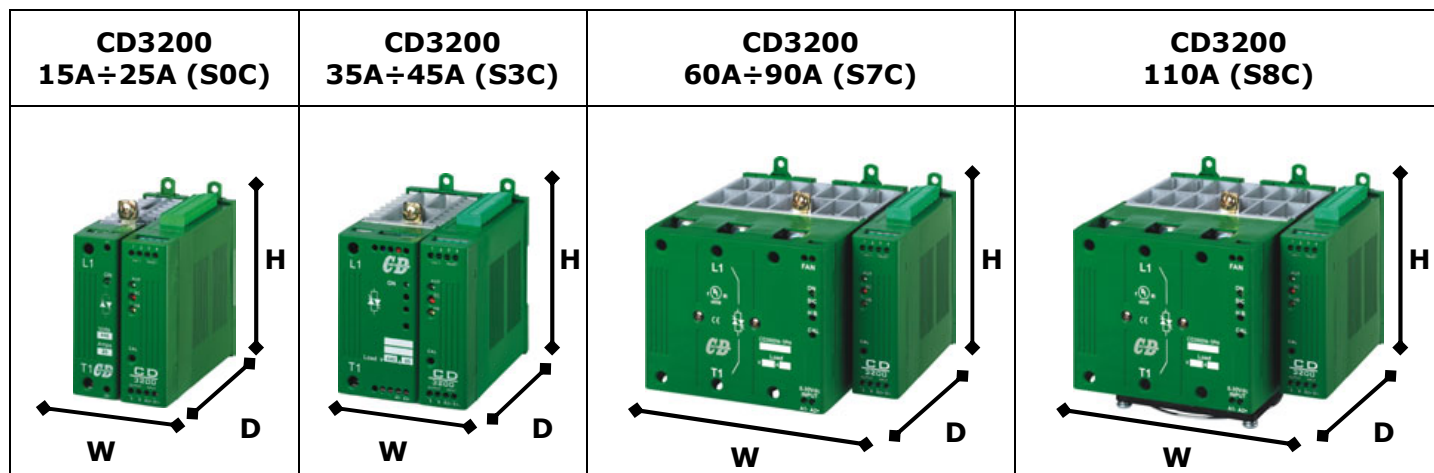

Size	W(mm)	H(mm)	D(mm)	Weight (kg)
15A (S0C)	63	120	120	0,7
25A (S0C)	63	120	120	0,7
35A (S3C)	85	120	120	0,95
45A (S3C)	85	120	120	0,95
60A (S7C)	148	120	159	2
90A (S7C)	148	120	159	2
110A (S8C)	148	138	159	2,15

## 6.3 CT dimensions

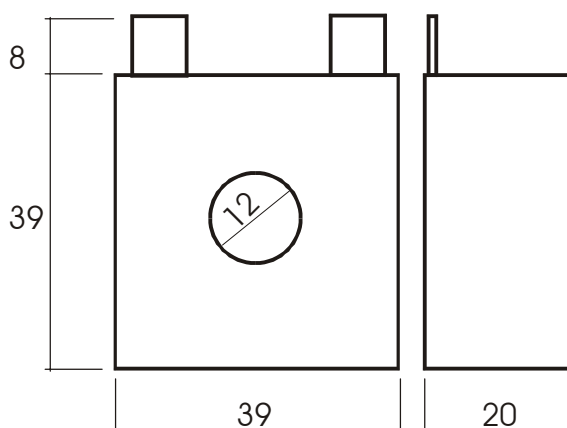

## 6.4 Fixing holes

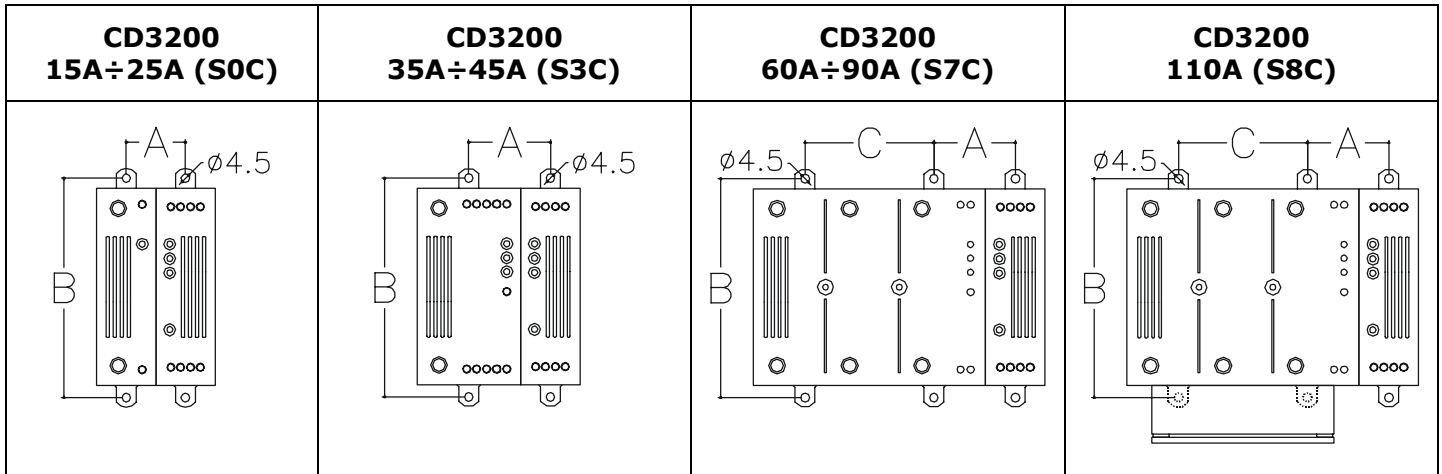

Size	A(mm)	B(mm)	C(mm)
15A (S0C)	30	110	-
25A (S0C)	30	110	-
35A (S3C)	41	110	-
45A (S3C)	41	110	-
60A (S7C)	41	110	65
90A (S7C)	41	110	65
110A (S8C)	41	110	65

## 7 Wiring instructions



**Caution:** this procedure must be performed only by qualified persons.

The Thyristor unit could be susceptible to interferences lost by near equipments or by the power supply, for this reason in accord to the fundamental practices rules is opportune take some precautions:

- The electronic circuit of the Thyristor unit must be supplied from a dedicated voltage and not with inductive or capacitive loads. We recommend the use of a screened transformer.
- The coil contactor, the relays and other inductive loads must be equipped with opportune RC filter.
- Use shielded bipolar cables for all the input and output signals.
- The signal cables must not be near and parallel to the power cables.
- Local regulations regarding electrical installation should be rigidly observed.

For safety connect the heat-sink to the earth with his terminal.

### 7.1 Removing the cover

Remove plastic Cover For all size

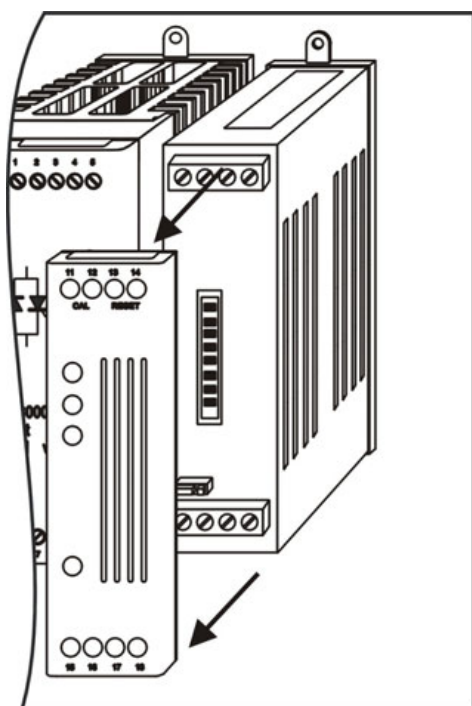

To remove the board Pull the PCB

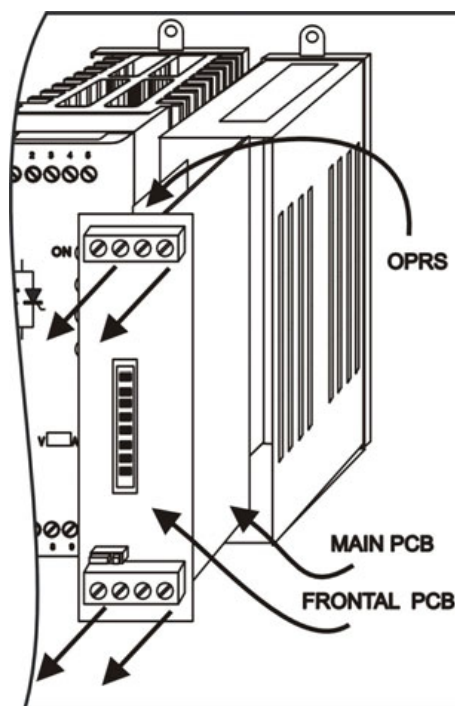



## 7.2 Wiring details

Use copper cables and wires rated for use at 75°C only.

### 7.2.1 Power cable torque (suggested)

Current	Connector Type	Torque Lb-in (N-m)	Wire Range AWG / kcmil	Wire Terminal
15A,25A 35A,45A	M5 Screw	26.6 (3.0)	8	UL Listed (ZMVV) Wire Pin
60A,90A 110A	M6 Screw	70.8 (8.0)	1	UL Listed (ZMVV) Fork/Spade Terminal Copper Tube Crimp. Lug

### 7.2.2 Power cable dimensions (suggested)

Current	Supply			Load		
	Cable		Screw M	Cable		Screw M
	mm <sup>2</sup>	AWG		mm <sup>2</sup>	AWG	
15A (S0C)	4	12	M5	4	12	M5
25A (S0C)	6	10	M5	6	10	M5
35A (S3C)	10	8	M5	10	8	M5
45A (S3C)	10	8	M5	10	8	M5
60A (S7C)	16	6	M6	16	6	M6
90A (S7C)	35	3	M6	35	3	M6
110A (S8C)	35	3	M6	35	3	M6

### 7.2.3 Cable dimensions (suggested) of Earth and of the Command Terminals

Current	Earth			Command Terminals		
	Cable		Screw M	Cable		
	mm <sup>2</sup>	AWG		mm <sup>2</sup>	AWG	
15A (S0C)	4	12	M5	0,50	18	
25A (S0C)	6	10	M5	0,50	18	
35A (S3C)	6	10	M5	0,50	18	
45A (S3C)	6	10	M5	0,50	18	
60A (S7C)	6	10	M5	0,50	18	
90A (S7C)	6	10	M5	0,50	18	
110A (S8C)	6	10	M5	0,50	18	

## 7.3 Power Terminals



**Warning:** Before connecting or disconnecting the unit check that power and control cables are isolated from voltage sources.

Terminal	Description
L1	Line Input Phase 1
T1	Load Output Phase 1

## 7.4 Command Terminals



**Warning:** Before connecting or disconnecting the unit check that power and control cables are isolated from voltage sources.

### 7.4.1 Upper Terminal

Terminal	Description
1	(-) External Calibration 24 Vdc max
2	(+) External Calibration 24 Vdc max
3	Reset
4	Reset
5	(+) CD32000 Output Command signal (Internal Connections)
6	(-) CD3200 Output Command signal (Internal Connections)
A2+	(+) Input command signal 0÷10V,4÷20mA,POT
A1-	(-) Input command signal 0÷10V,4÷20mA,POT

(see par. 11.1)

### 7.4.2 Lateral Terminal

Terminal	Description
7	RS485 A
8	RS485 B
9	Output +8Vdc stabilized 1 mA MAX
10	HB relay contact (Max 500mA , 125Vac) Optional
11	HB relay contact (Max 500mA , 125Vac) Optional
12	External current limit profiling
13	Current Transformer "CT1" input
14	Current Transformer "CT1" input
15	Not connected
16	Voltage Supply for Electronic Boards (Auxiliary)
17	Earth
18	Voltage Supply for Electronic Boards (Auxiliary)

(see par. 11.1)

## 7.5 Diagram of control connection from size 15A to 25A



**Caution:** this procedure must be performed only by qualified persons.

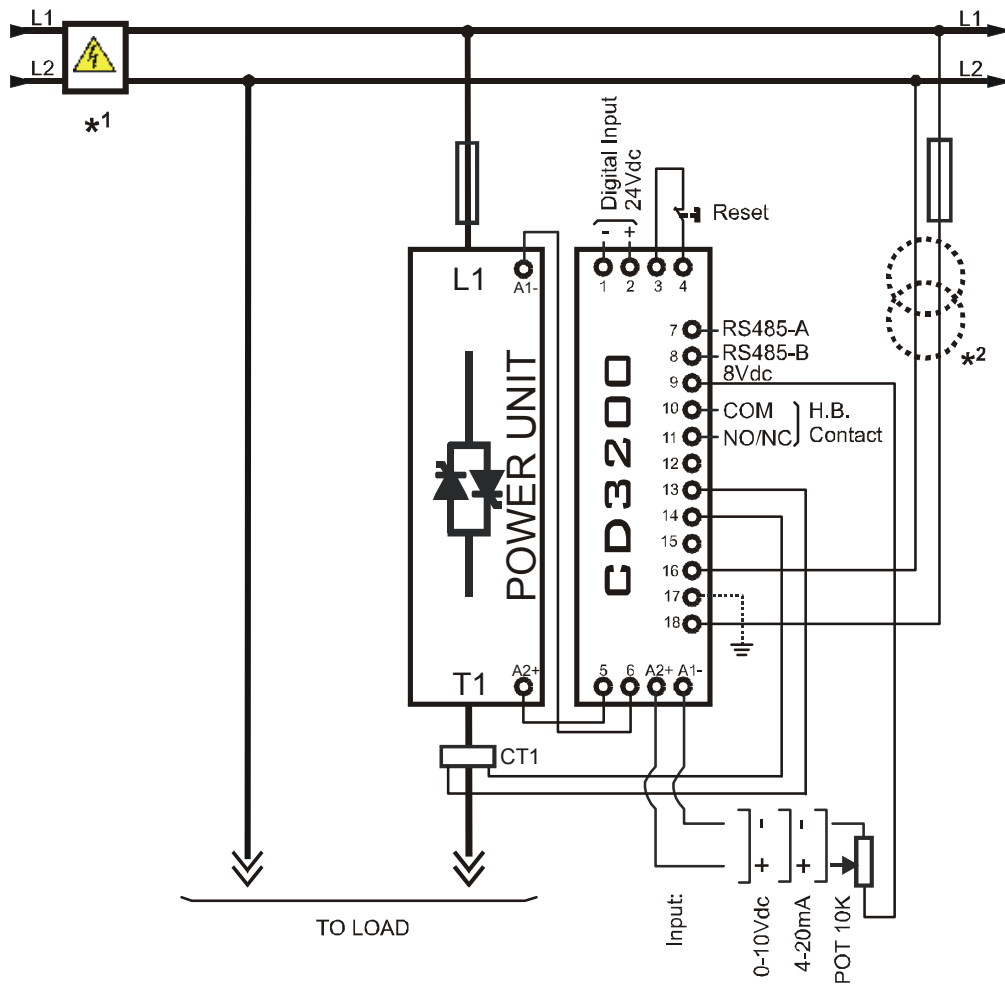

**NOTE:**

- \*1 The user installation must be protecting by electromagnetic circuit breaker or by fuse isolator.
- \*2 The auxiliary voltage supply of the CD3200 unit must be synchronized with load voltage power supply. If the Auxiliary Voltage (written on the identification label) is different from Supply Voltage (to the load), use an external transformer as designated.
- To work, the Reset Contact on terminal 3 and 4 must be closed.

**Load Type**

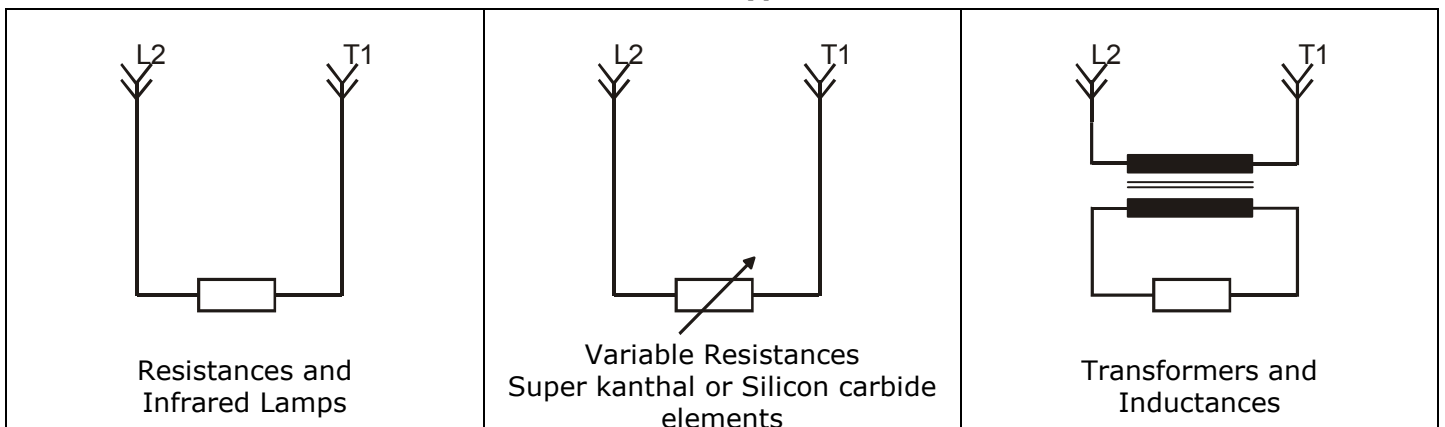

## 7.6 Diagram of control connection from size 35A to 45A



**Caution:** this procedure must be performed only by qualified persons.

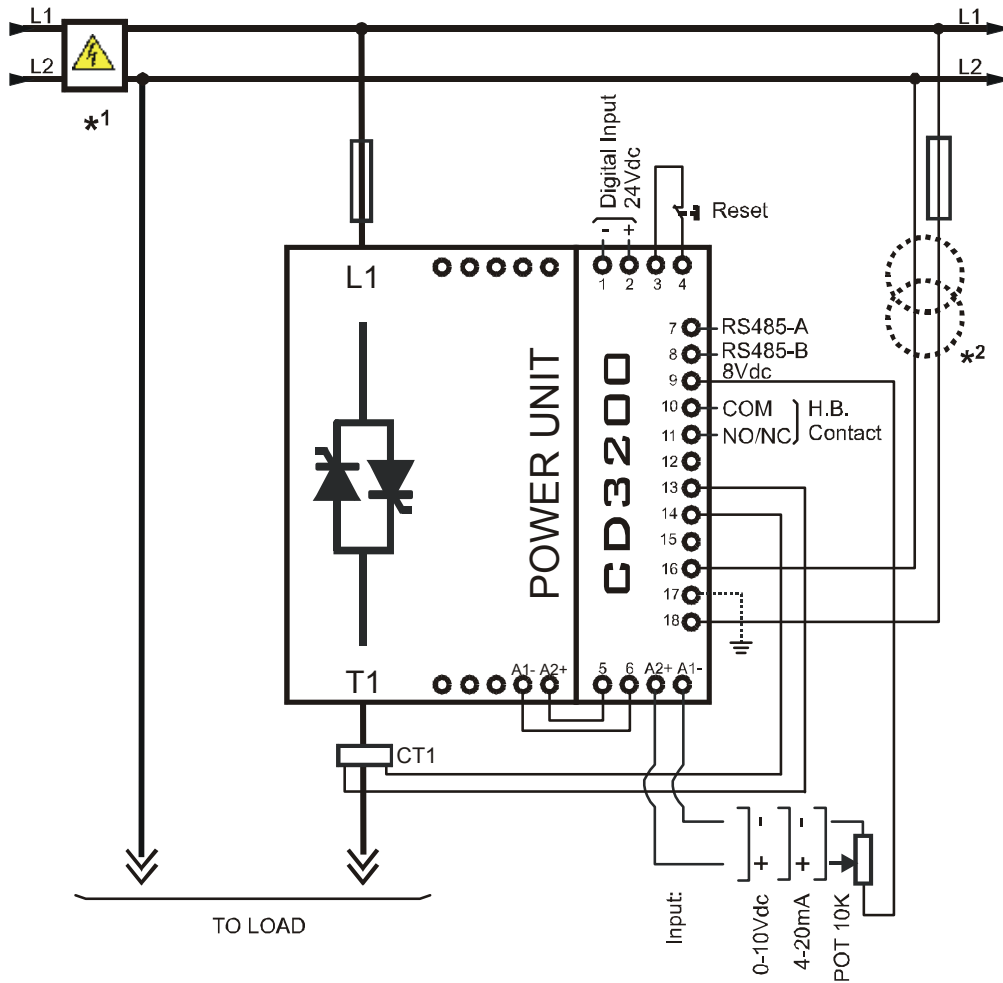

**NOTE:**

- \*1 The user installation must be protecting by electromagnetic circuit breaker or by fuse isolator.
- \*2 The auxiliary voltage supply of the CD3200 unit must be synchronized with load voltage power supply. If the Auxiliary Voltage (written on the identification label) is different from Supply Voltage (to the load), use an external transformer as designated.
- To work, the Reset Contact on terminal 3 and 4 must be closed.

**Load Type**

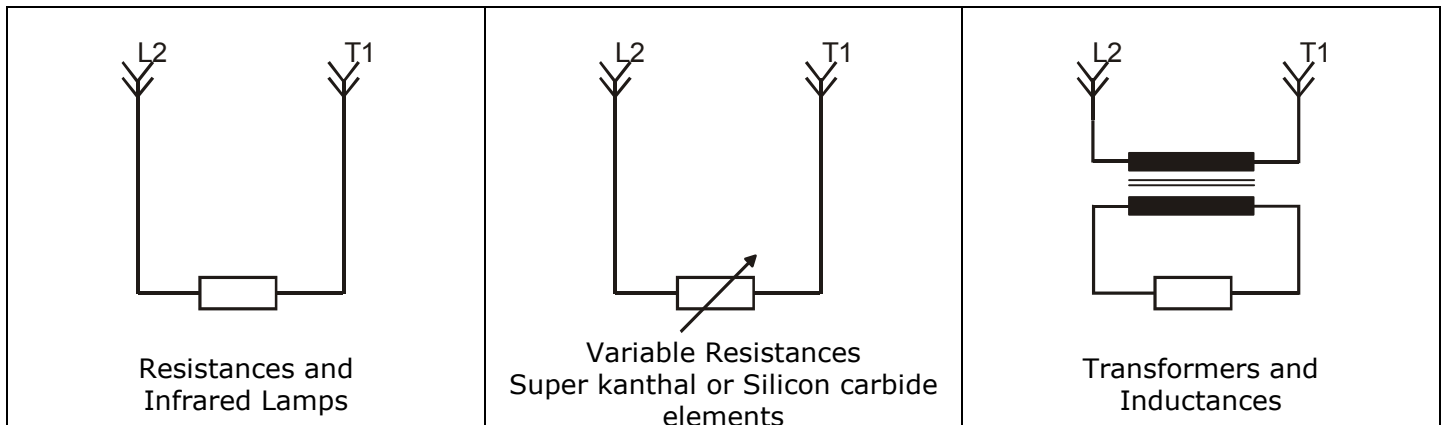

## 7.7 Diagram of control connection from size 60A to 110A



**Caution:** this procedure must be performed only by qualified persons.

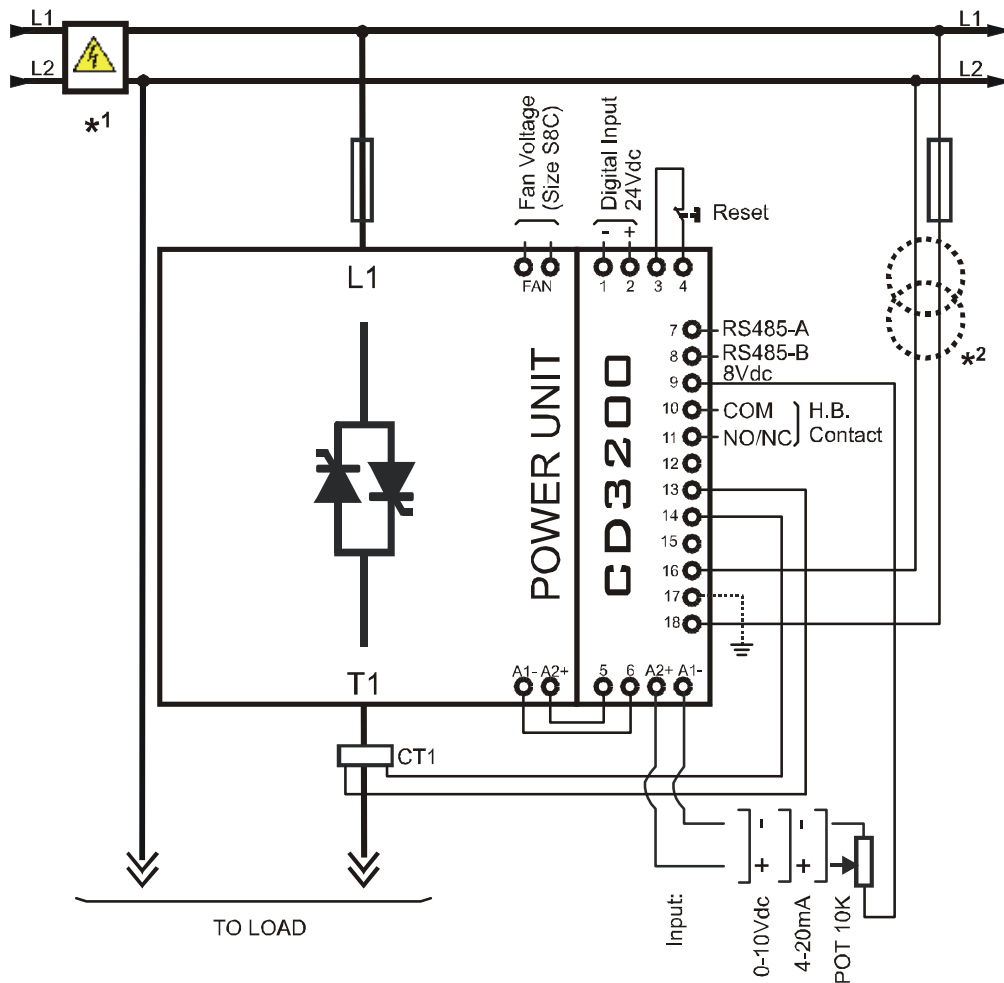

**NOTE:**

- \*1 The user installation must be protecting by electromagnetic circuit breaker or by fuse isolator.
- \*2 The auxiliary voltage supply of the CD3200 unit must be synchronized with load voltage power supply. If the Auxiliary Voltage (written on the identification label) is different from Supply Voltage (to the load), use an external transformer as designated.
- To work, the Reset Contact on terminal 3 and 4 must be closed.

**Load Type**

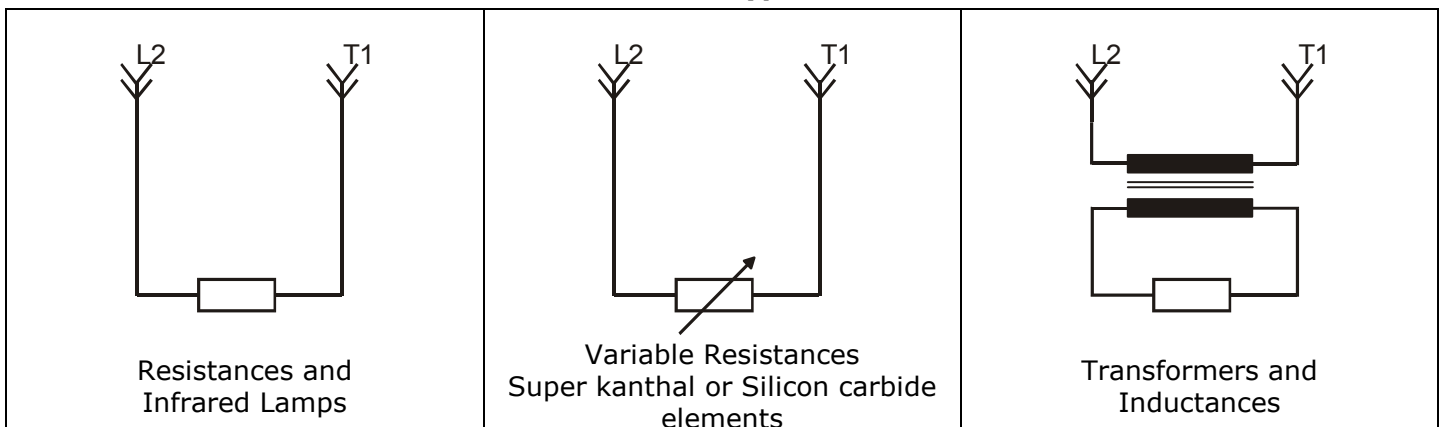

## 8 Power output features

Current (A)	Voltage range (V)	Repetitive peak reverse voltage		Latching current (mAeff)	Max peak one cycle (10msec.) (A)	Leakage current (mAeff)	I <sup>2</sup> T value max tp=10msec	Frequency range (Hz)	Power loss I=Inom (W)	Isolation Voltage Vac
		(480V)	(600V)							
15A	24÷480	1200	1200	150	230	15	610	47÷70	18	2500
25A	24÷480	1200	1200	150	230	15	610	47÷70	30	2500
35A	24÷600	1200	1600	250	400	15	780	47÷70	42	2500
45A	24÷600	1200	1600	250	600	15	1800	47÷70	54	2500
60A	24÷600	1200	1600	450	1000	15	4750	47÷70	72	2500
90A	24÷600	1200	1600	450	2000	15	19100	47÷70	108	2500
110A	24÷600	1200	1600	450	1540	15	11300	47÷70	137	2500

### 8.1 Derating curve

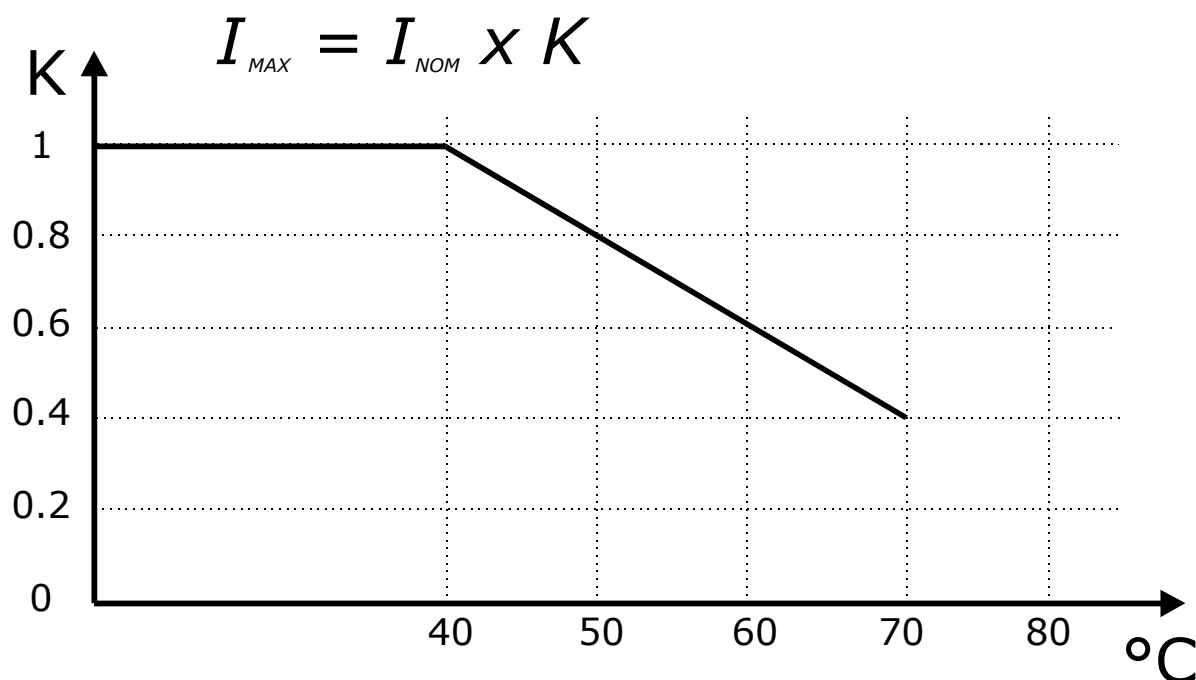

### 8.2 Cooling fans

The thyristor units from size 110A are equipped with a cooling fan. The supply voltage is standard 230VAC ±15% 50/60Hz or optional 110VAC ±15% 50/60Hz.



The fan's power consumption is below listed:

Size	CE Number of fans	cUL us LISTED Number of fans
110A (S8C)	One Fan - 16W	One Fan - 16W

## 9 Led status and Alarms

### 9.1 LED Status Table

In front of the thyristor unit there are LED that indicates the state of the Electronic cards:

LED For All size	STATUS	DESCRIPTION
Aux	○	The power supply is not connected or fault on the electronic board
	●	The power supply is not connected and the Electronic board is OK
ON	○	OFF Condition (Load IS NOT Powered)
	●	ON Condition (Load IS Powered)
SC	○	SCR OK
	●	SCR short circuit
		No External Enable (see par. 11.4)
HB	○	Load OK
	●	Load Fault
	○	= OFF
	●	= ON
		= Flashing

### 9.2 Not Critical Alarm

The Not Critical Alarm, doesn't stop the thyristor unit.

When one of these Not Critical Alarm is active, the HB relay change status (see par. 11.5)

#### 9.2.1 SCR Short Circuit (only with the HB option)

This alarm is active when the thyristor unit read the output current in absence of the input signal. This is possible if there are a short circuit on the thyristor or if there are a wrong wiring of the load.

When the problem is solved is necessary use the digital input: "Reset"  
(Terminals 3-4)

### 9.2.2 Heater Break alarm HB (only with the HB option)

This alarm is active when the load current decrease under the threshold set on the parameter P126H (see par. 13).

The Heater Break alarm could be active also if there are a wrong wiring of the load.

When the problem is solved is necessary use the digital input: "Reset"

(Terminals 3-4).

The Heater Break circuit to work properly must have at least an input of 25% of the nominal current.

H.B. circuit read load current via a current transformer 25-50/0.05 or 100/0.05 depending on thyristor size.

Minimum current is 30% of the current transformer size's. If load current is below this value make two turns or more around current transformer. H.B. circuit also diagnoses fuse failure.



**Caution:** *In the first start, and each time that the load is replaced, it's necessary make the Calibration procedure.*

## 9.3 Calibration Procedure

The Calibration procedure is an automatic procedure that save in memory the value of load current.

To make the Calibration procedure follow these steps:

- Turned completely in counter-clockwise sense the trimmer R13 (see par 10.3 )
- Give the power supply
- Press the "CAL" button on front unit, or use the configurable digital input (see par. 11.4).
- All LEDs are on, this means that calibration procedure is active.
- Turn the trimmer R13 in clockwise sense and set the wished current limit.
- After a minute the values of voltage and current are stored in memory.
- the CD3200 comes back to the initial situation.

The Calibration procedure is done.

## 10 Firing type

Choose an correct firing type allows to optimize the thyristor unit for the installed load.

The firing type has already configured in line with customer requirements that are defined in the Order Code. The Order Code is written on the identification label.

However, if you wish to change the firing type you can use the software configurator or the parameter on serial link (see par. 13).



**Caution:** *this procedure must be performed only by qualified persons.*



### 10.1 Phase Angle (PA)

The Phase Angle firing allow the control of the power on the load, for this firing the thyristor can be in conduction only for a part of the voltage cycle.

This part of the voltage cycle is adjustable in function of the input signal from 0 at 100%.

The PA firing is normally used for control the inductive loads, and is also possible control a primary of transformer coupled with the cold resistances like: Superkanthal, Molybdenum, Platinum, Tungsten or Quartz Lamp. The only disadvantage with phase angle is the possible generation of interferences that however can be reduced with opportune filters.

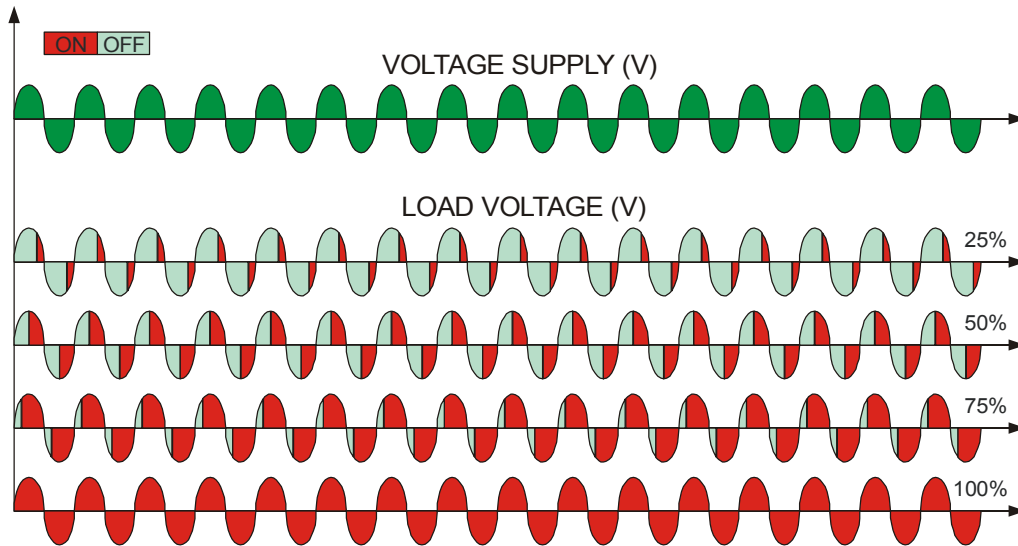

### 10.2 Soft Start with Phase Angle (S+PA)

This is an additional function to the Phase Angle. The firing angle of the thyristor increase or decrease up to the final setpoint value.

The Soft start ramp is an important feature to reduce the inrush current with transformers during the during the cycle of magnetization or with cold resistance that are near to the short circuit when they are supplied.

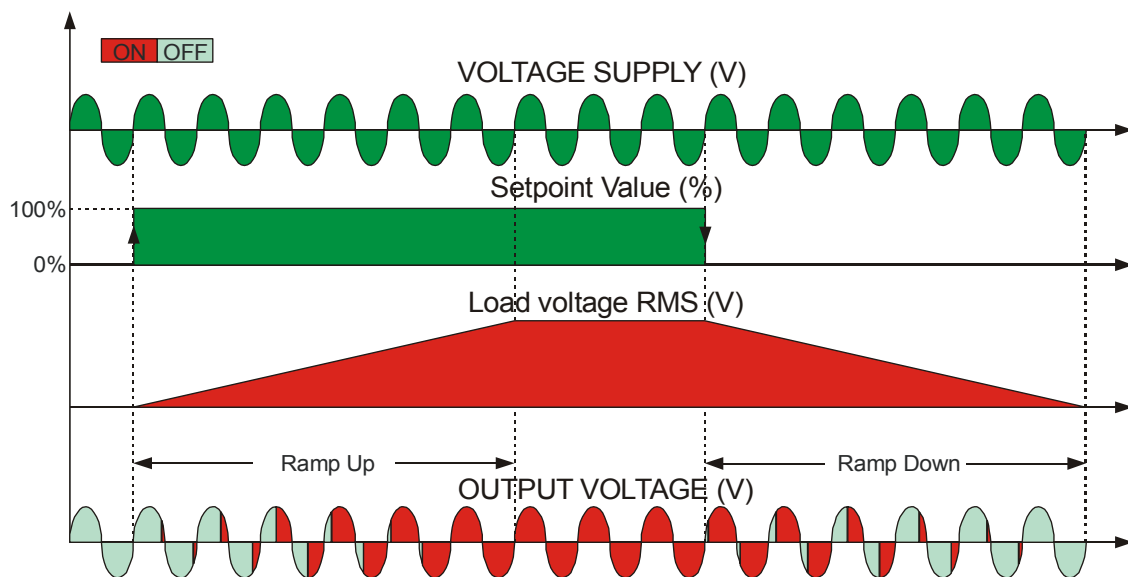

## 10.3 Action of the Limit Current

The Current Limit control the firing angle of the thyristor to maintain the RMS current under the set value.

When the current exceeds this value, the voltage is decreased up to reach the current limit set

**I Load  $\leq$  I Limit Set**

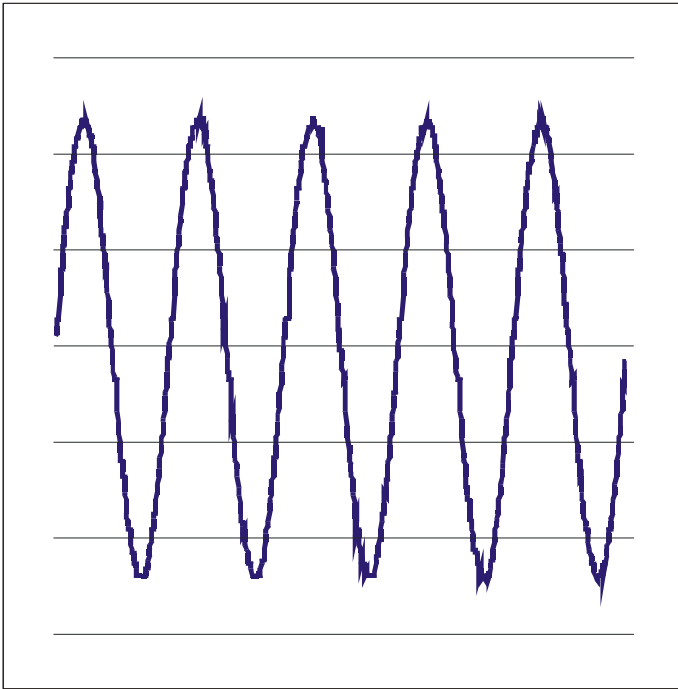

**I Load  $>$  I Limit Set**

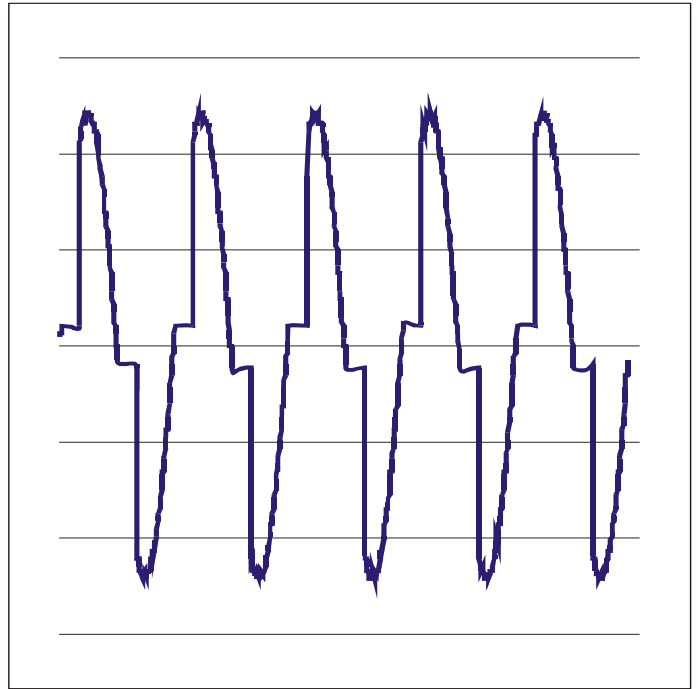

### 10.3.1 Current Limit Set

The Current limit is set up through the R13 trimmer on Frontal Board PCB (see par. 11.1)

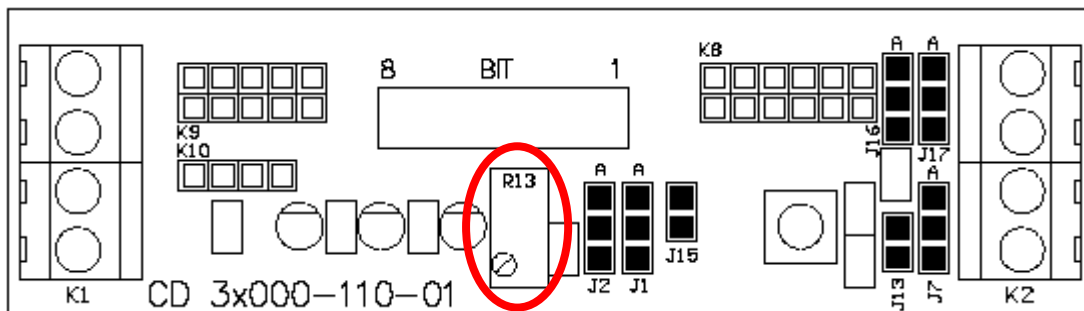

Turned completely in counter-clockwise sense, will be Current limit = 0%.

Turned completely in clockwise sense, will be Current limit = 100% of the Max value of current transformer (25/0.05 ,50/0.05 o 100/0.05 depending on thyristor size).

Minimum current is 25% of the current transformer size's. If load current is below this value make two turns or more around current transformer. H.B. circuit also diagnoses fuse failure.

If the External current limit profiling is used, before turning the R13 trimmer, supplying with 10Vdc the secondary analogic input (see par. 11.3.3)..



**Caution:** this procedure must be performed only by qualified persons

## 10.4 Feed-back type

The Feed-back type has already configured in line with customer requirements that are defined in the Order Code. The Order Code is written on the identification label.

However, if you wish to change the Feed-back type you can use the software configurator or the parameter on serial link (see par. 13).



**Caution:** *this procedure must be performed only by qualified persons..*

If the configurable digital input has set like Feed-Back Selection (see par. 11.4), it's possible to change the select Feed-Back with the Voltage Feed-Back (V) simply activating the input.

The feed-back defines the Control Mode. It's possible to have:

- V=Voltage feed-back.  
The input signal is proportional to the output voltage. This means that input signal becomes a voltage demand. This control mode compensates the voltage fluctuation of the incoming line supply.
- I=Current feed-back.  
The input signal is proportional to the current output. This means that input signal becomes a current demand. This control mode maintain the current also if the load impedance changes.
- V<sup>2</sup>=Square Voltage feed-back.  
The input signal is proportional to the output square voltage. This means that input signal becomes a power demand. The power remains constant if the load impedance doesn't change.
- VxI= Power feed-back.  
The input signal is proportional to the power output. This means that input signal becomes a power demand. The power remains constant also if voltage and load impedance change. This feed-back is used with silicon carbide elements that change its resistive value with temperature and with age. In addition it compensate the voltage fluctuation of the incoming line supply.

**If the user change the type of feed-back, it's necessary repeat the calibration procedure (see par. 9.3)**

## 11 Connection description

### 11.1 Access to the Electronic boards

To have access to the electronic boards the user must removing the unit's cover (see par.7.1)



**Warning:** Before operate, be sure that power and control cables are isolated from voltage sources

**Front PCB**

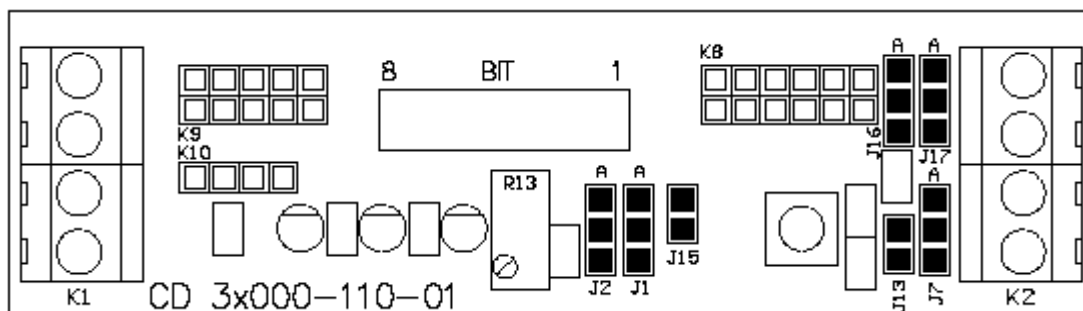

**Main PCB**

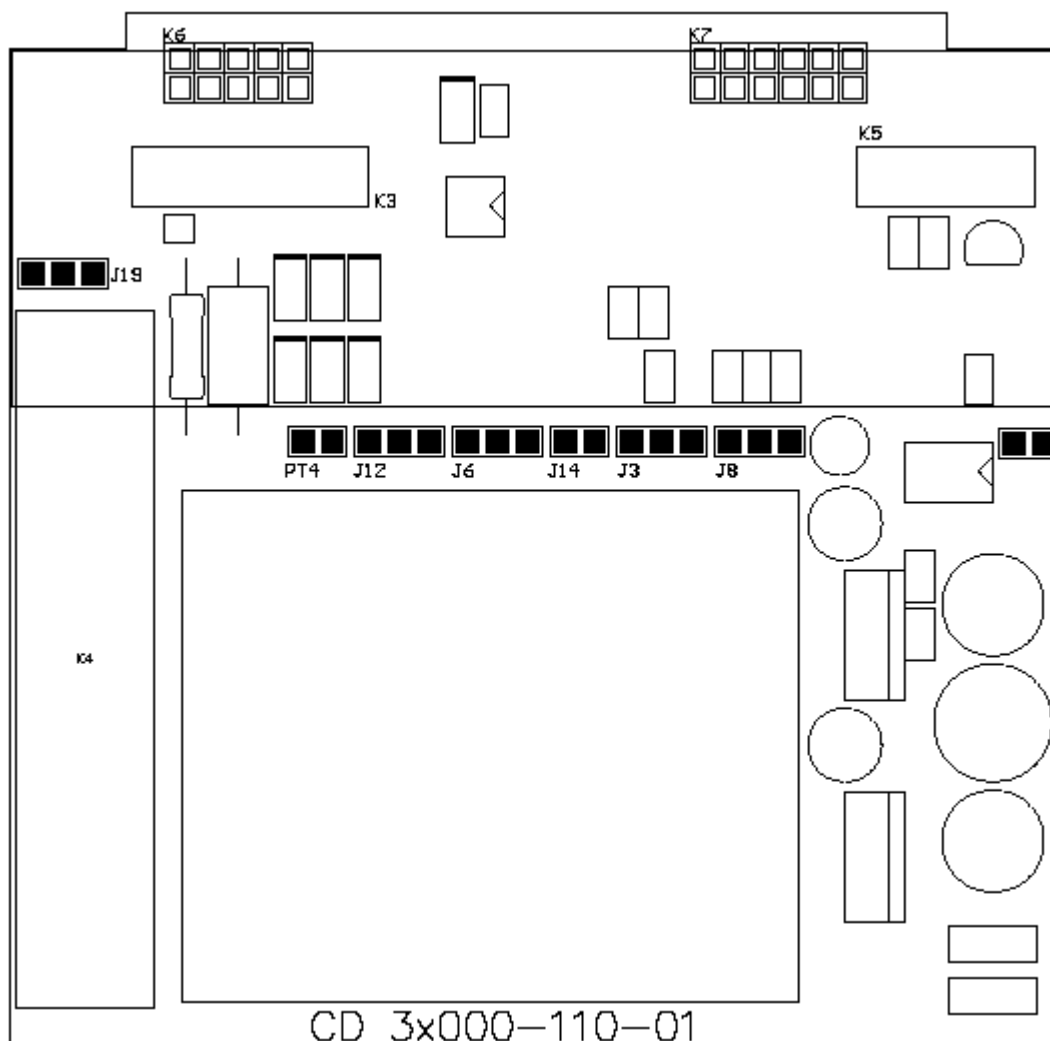

## 11.2 Supply the Electronic Board

The CD3200 thyristor unit, to work, requires a voltage supply for the electronic boards. The Max consumption is 10VA.

The voltage supply for the electronic boards is configured in line with customer requirements that are defined in the Order Code. The Order Code is written on the identification label.



**Warning:** Before connecting or disconnecting the unit check that power and control cables are isolated from voltage sources.

Terminal	Description
16	Voltage Supply for Electronic Boards (Auxiliary Voltage)
17	Earth
18	Voltage Supply for Electronic Boards (Auxiliary Voltage)

To change auxiliary supply voltage sold the correct link-jumper on main PCB:



**Warning:** this procedure can be done just by specialized personnel.

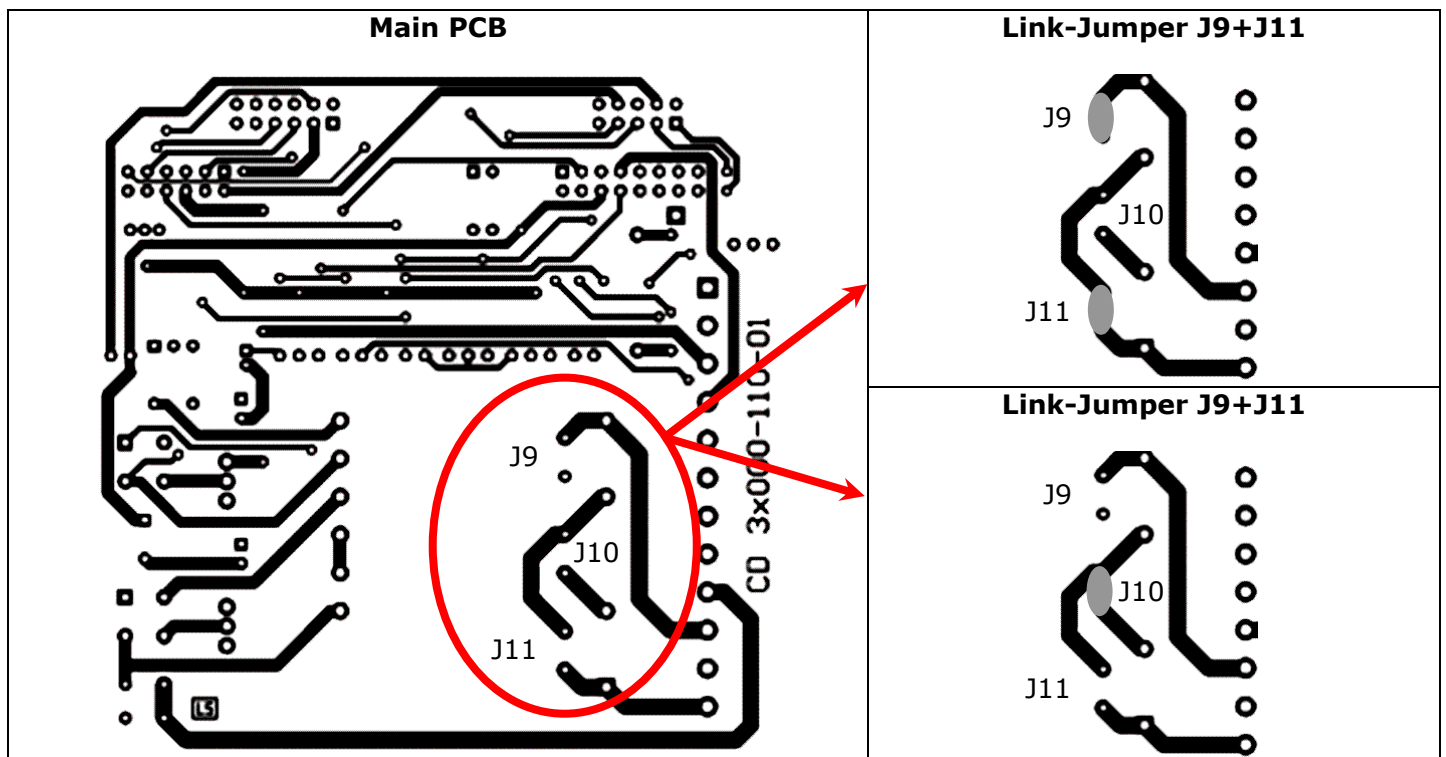

Transformer Type	Link-Jumper J9+J11	Link-Jumper J10
TR-605 120V	90:130V	-
TR-605 230V	170:265V	300:530V
TR-605 300V	230:345V	510:690V

- The type of mounted transformer depends of the chosen Auxiliary Voltage in the order code. (see par. 5.2)
- If the Auxiliary Voltage (written on the identification label) is different from Supply Voltage (to the load), use an external transformer with primary equal to load voltage and secondary equal to the Auxiliary Voltage.

### 11.3 Analog Inputs

CD3200 thyristor unit have have an analogue input to drive the output and a second analogue input that can be use for external current profiling

#### 11.3.1 Input command signal configuration (Terminals A2+ and A1- see par. 7.4)

The Input command signal is already configured in line with customer requirements that are defined in the complete product code. The product code is written on the identification label. However, if you wish to change the input type (i.e. from 0÷10V to 4÷20mA) proceed as follows:



**Warning:** this procedure can be done just by specialized personnel

**Front PCB**

To configure the input type, set the jumper as below represented:

Type	Input features		J7	J16	J17
0÷10V	Impedance	10KΩ	C-B	B-A	B-A
POT	Impedance	10KΩ min	C-B	B-A	B-A
4÷20mA	Impedance	100Ω	B-A	B-A	B-A

**When operator finishes to configure the hardware setting he must do the input calibration procedure**

**11.3.2 Input calibration procedure**



**Warning:** this procedure can be done just by specialized personnel

**This procedure is needed only if you change the input type**

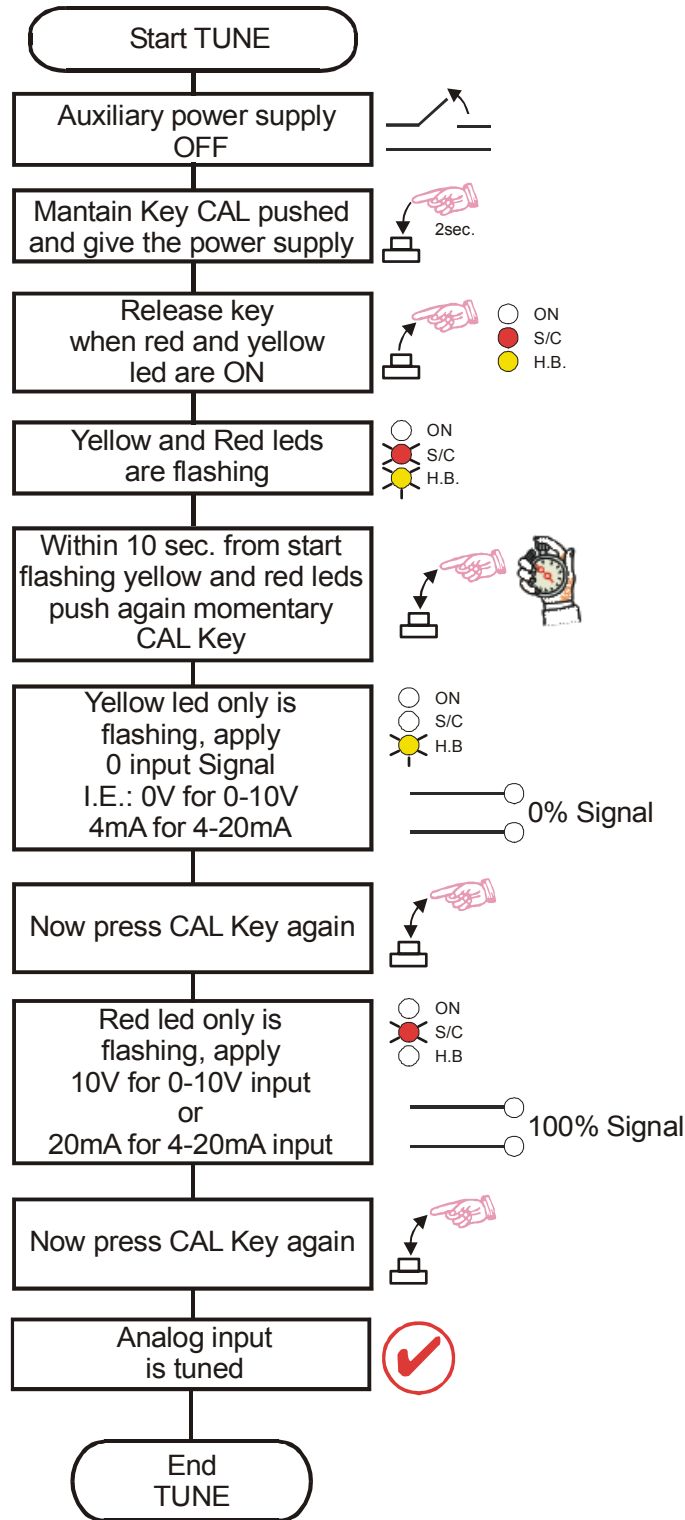

**11.3.3 Secondary input (Terminals J2 & J1- see par. 7.4)**

This analogue input 0-10V may be configured for External current limit profiling. The Secondary input is already configured in line with customer requirements that are defined in the complete product code. The product code is written on the identification label. However, if you wish to change the input type proceed as follows:



**Warning:** this procedure can be done just by specialized personnel

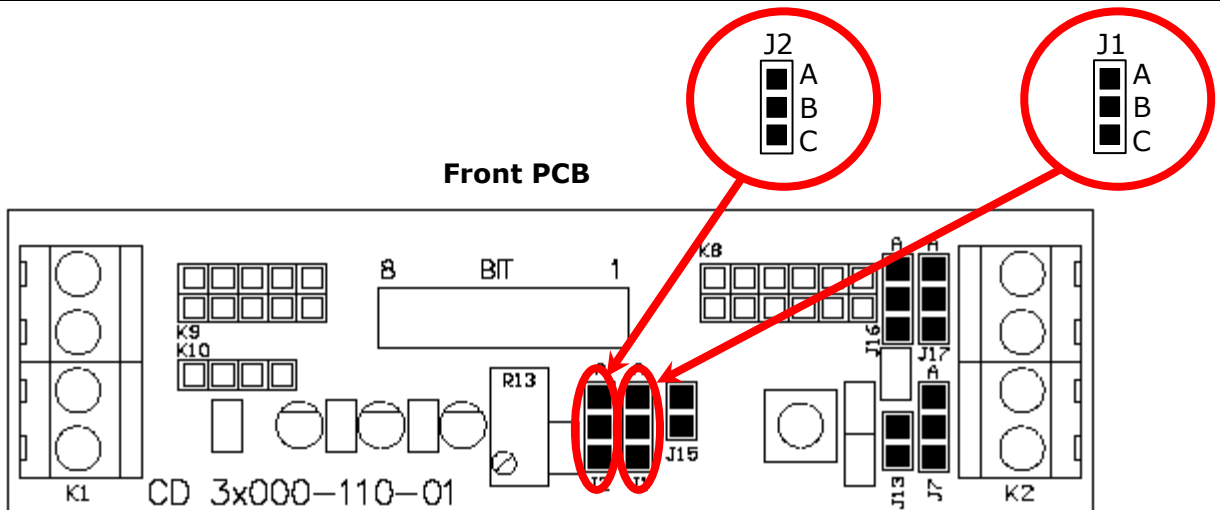

To configure the input type, set the jumper as below represented:

Current Limit	J2	J1
Regulation through the R13 trimmer, mounted on the front PCB. (secondary input not used)	C-B	C-B
Regulation through the secondary input (External current limit profiling)	B-A	C-B

**If the user change the type of Secondary input, it's necessary repeat the calibration procedure (see par. 9.3)**

**11.4 Digital Input**

CD3200 thyristor unit has two digital inputs.



**11.4.1 Configurable Input (Terminals 1 and 2 see par. 7.4)**

This digital input is configurable and can be:

- External Calibration (Standard):  
The Calibration input activates the Calibration procedure that is necessary if you use the Heater break alarm (see par. 9.3). Supply with 24Vdc terminals 1-2 to start the Heater Break procedure.
- External Enable:  
Without Enable the out is always to zero and red led (SC) flashing, otherwise the out will follow the input signal.
- Feed-back Selection:  
to switch the set Feed-back with the voltage Feed-back (V)  
Without Digital Input the Unit use the voltage Feed-back, otherwise use the set Feed-back.

To configure the input type, set the jumper as below represented:



**Warning:** this procedure can be done just by specialized personnel

**Main PCB**

Type	J12	J6	J14
External Calibration	C-B	C-B	Open
External Enable	B-A	Open	Open
Feed-back Selection *	C-B	Open	Close

\* With the Feed-back Selection open the jumper J15 on the Front PCB board

**If you use the input like External Enable or like Feed-back Selection, is not possible use the input for the Calibration Procedure**

**11.4.2 Reset (Terminals 3 and 4 see par. 7.4)**

The Reset Alarm is used for restore the unit after an alarm occurs (see par. 9.2). Open link to terminals 3-4 to stop the CD3200 thyristor unit and reset the alarm.

## 11.5 Digital Output

CD3200 thyristor unit with HB option has 1 digital output with relay contact (Max 500mA, 125Vac) that gives indications of the alarms state, the contacts can be (NO or NC).

### 11.5.1 HB alarm contact (Only with HB Option - see par. 9.2)

The standard contact used for this output is normally open (NO):

- In normal conditions (without alarm) and with auxiliary power supply, the contact to the terminals has opened (relay coil energized).
- In alarm condition or without auxiliary power supply the contact to the terminals is closed (relay coil not energized).

if you wish to change the alarm contact put the jumper as shown:



**Caution:** this procedure must be performed only by qualified persons

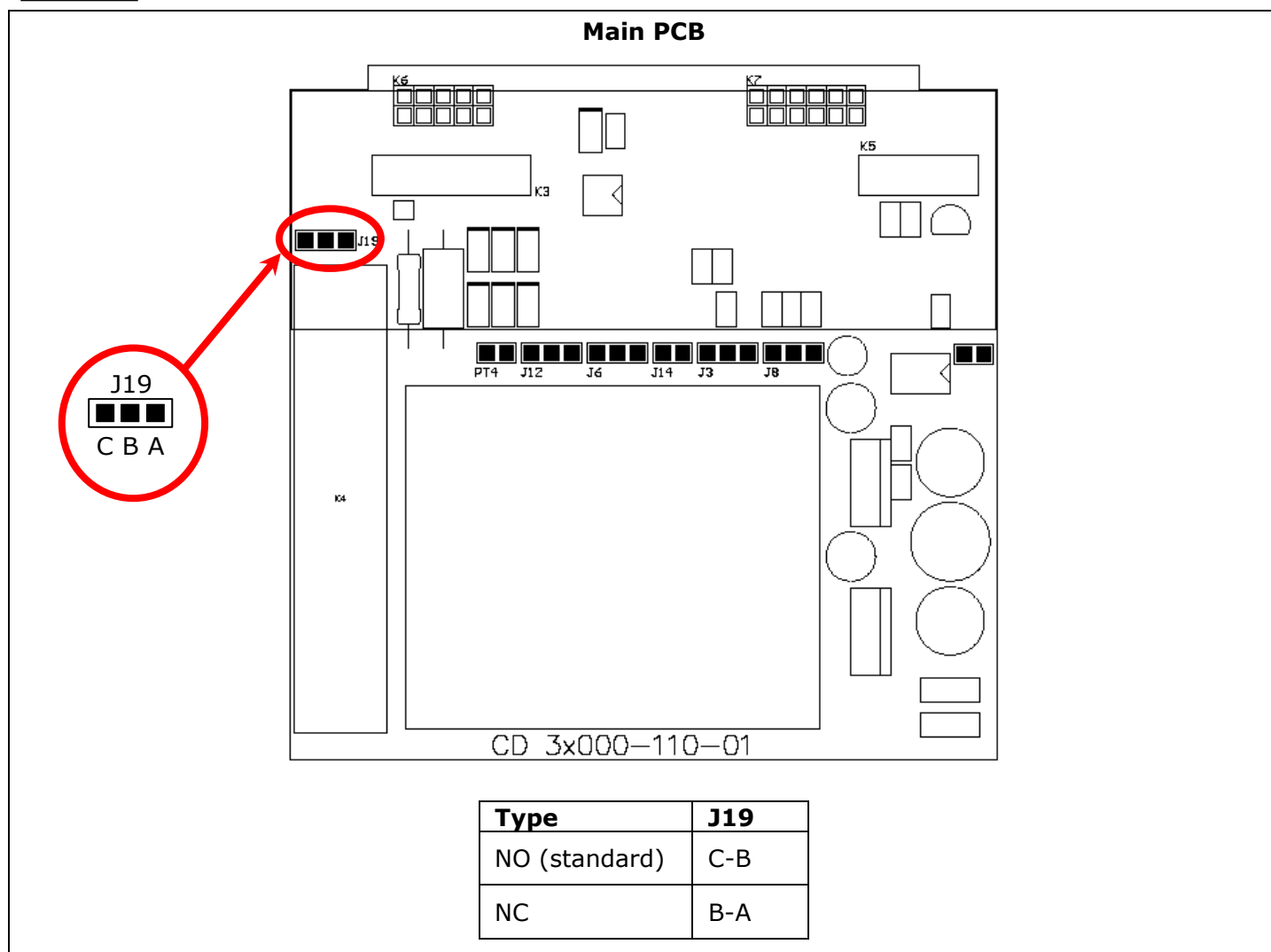

### 11.6 PG Connector

The PG Connector is used to configure the thyristor unit with the configuration software and with the programming cable.  
The programming cable is not included.

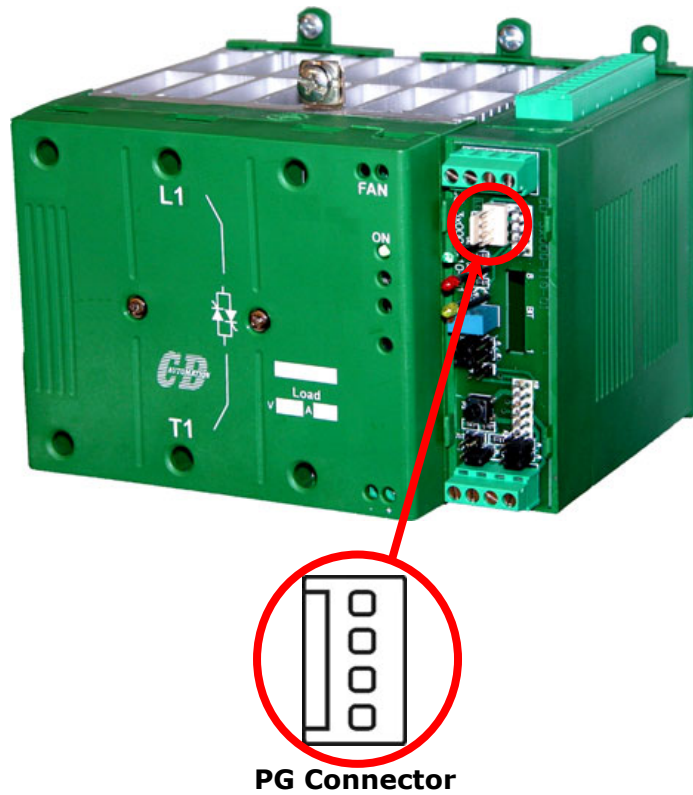

### 11.7 RS485 Serial Port

The serial communication port is on Terminals 7 and 8.  
On this port may be done a network up to 255 unit.

Terminal	Description
7	RS485 A
8	RS485 B

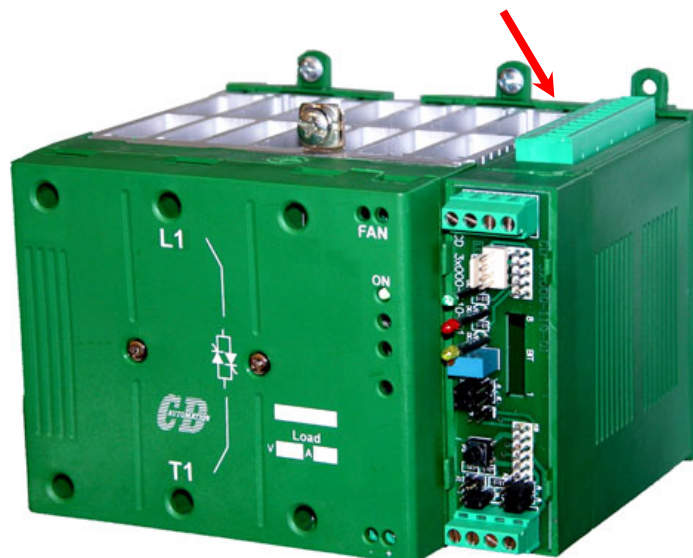

## 11.8 Address configuration

The thyristor unit is assigned a unique device address by the user in the range 1 (default) to 255. This address is used to recognise the messages queries to her assigned.

The thyristor unit does not respond at the messages queries that don't have the same assigned address. The thyristor unit will also accept global messages (Broadcast) sends at the address 0. No responses are returned for globally addressed queries.

To configure communication address remove cover and set the dip-switch as below specified:

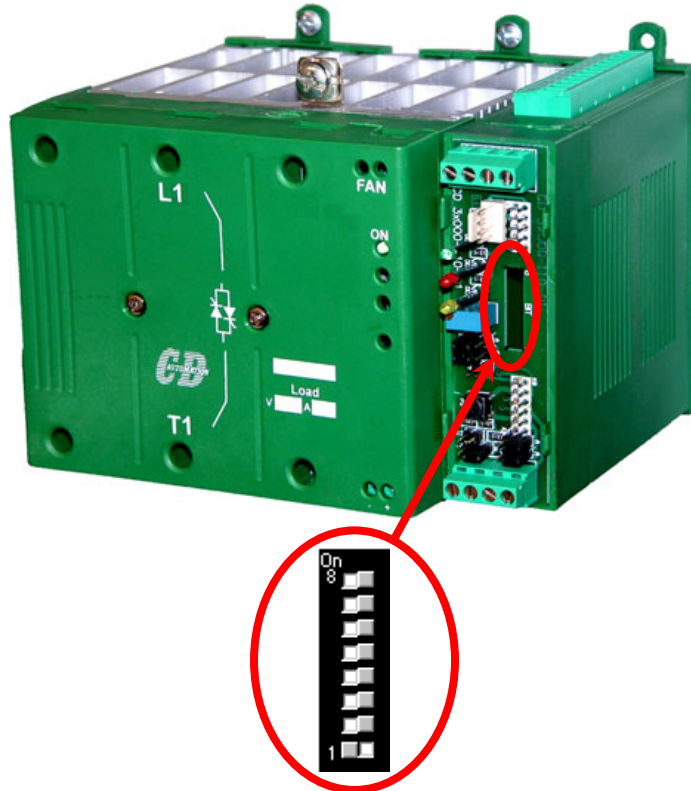

**Dip Switch**

Convert the Address Number in Binary for Example: 150 Dec = 10010110 Bin  
 The dip switch number corresponds to the bit number:

Address Number	Dip Switch Number							
	8	7	6	5	4	3	2	1
150 Dec -> 10010110 Bin	1 (On)	0 (Off)	0 (Off)	1 (On)	0 (Off)	1 (On)	1 (On)	0 (Off)

For convert the Number in Binary you can use this method:

Dip Switch Number have this value:

Value	Dip Switch Number							
	8	7	6	5	4	3	2	1
	128	64	32	16	8	4	2	1

The Address Number Ex. 150 = 128(Dip 8) + 16(Dip 5) + 4(Dip 3) + 2(Dip2)

## 12 MODBUS communication

The serial communication port of the thyristor unit is two-wire RS485 type.

This port use an half-duplex system.

When a Unit must transmit active the transmission line, and when there are not units in transmission the outputs are fixed to high impedance.

The serial communication port allows to communicate between the thyristor units and a MASTER device (ex. an computer or a terminal). The cable must be rated for use to data transfer.

### 12.1 MODBUS RTU Protocol

The communication is based on the standard industrial MODBUS RTU with the following restrictions:



- The Baud rate is 9600 Baud.
- The Preset Multiple Registers (Funct. 16) is limited to the writing of a single parameter for message.

The following MODBUS functions are supported:

Function	Description
03	Read Holding Registers
16	Preset Multiple Registers



The unit support the Broadcast messages:

It' possible send a Broadcast messages using the address 0, all the units respond at the message without sending back any reply.

### 12.2 Message Format

The transmission format is a 1 bit start, 8 date bit, and 1 bit stop with no parity verification.

Each message terminate after a said time of "time out", equal at 3.5 time of a character transmission, where there are not transitions on the transmission line.

The first Byte of each message is always the address of the unit that is a value from 1 to 255 or 0 for the broadcast messages, the second is always the function number, and the rest of the message depends of the function demand.



When a Slave receive an message, the unit send an answer with the same structure but with the information demanded.

Each message is followed by CRC (Cyclic Redundancy Check) with two byte. The CRC identify the incongruity situations of the message, in this case the receiver ignore the message.

The CRC is calculated in accordance with a formula that imply a recursive division of the data by a polynomial.

The polynomial divisor is:

$$2^{16} + 2^{15} + 2^2 + 1(\text{Hex } 18005)$$

but is modified in two ways:

- Since the bits order are reversed, then the binary pattern is also reversed, and the most significant bit (MSB) is the right-most bit.
- Since interest only the remainder, the right-most bit could be discarded.

Therefore, the polynomial divisor has value: Hex A001

#### Normal bit order:

Most significant bit																		Least significant bit
	Most significant Byte								Least significant Byte									

#### Reversed bit order:

Least significant bit																		Most significant bit
	Least significant Byte								Most significant Byte									

N.B.: With the reversed bit order, also the CRC16 returns the with the reversed bit order



The following flow-diagram show how to organize the CRC 16 bit.

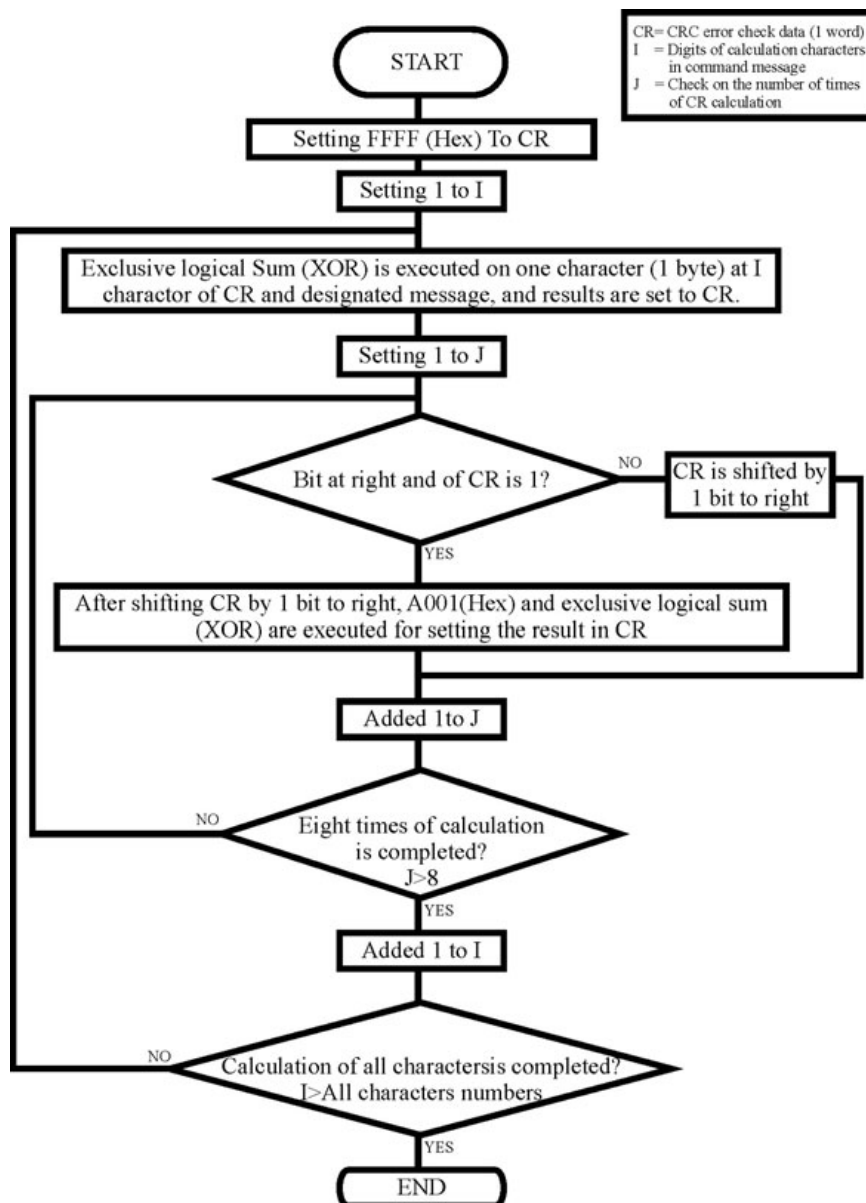

### C Language CRC 16 Example

```

static short CRC16 (unsigned char *p_first,unsigned char *p_last)
{
    unsigned int crc=0xffff;
    short j;
    for (;p_first<=p_last;p_first++)
    {
        crc ^= *p_first;
        for(j=8;j>0;j--)
        {
            if(crc & 0x0001)
            {
                crc = crc >> 1;
                crc ^= 0xA001;
            }
            else
            {
                crc = crc >> 1;
            }
        }
    }
    return (crc);
}
  
```

## 12.3 Read Holding Registers

This function reads the instantaneous value of a specified number of parameters from an address. The message is composed by 8 Byte: one Byte is for the address, one for the function (03 Hex), two Byte for the first parameter to read, two Byte for the total number of parameters to read and finally two Byte for the CRC:

Address Unit	Function	Address of the First Parameter		N° of the Parameter		CRC 16	
		HI	LO	HI	LO	LO	HI
	3 3Hex						

The answer is an echo of the first two Byte (address and function), one byte with the number of following byte to exclusion of the CRC, the demanded values and finally two Byte for the CRC:

Address Unit	Function	N° of Byte	First Parameter Value		...	Last parameter value		CRC 16	
			HI	LO		HI	LO	LO	HI
	3 3Hex								

## 12.4 Preset Multiple Registers

This function could write only a parameter for each message.

The message is composed by 11 Byte: one Byte for the address, one for the function (10 Hex), two Byte for first parameter to write, two Bytes for the N° of parameters, fixed to 1 (0001 Hex), one Byte with the number of following Bytes, fixed to 2 (02 Hex), two Byte for the CRC:

Address Unit	Function	Address of the First Parameter		N° of the Parameter		N° of Byte	Value to write		CRC 16	
		HI	LO	0	1		2	HI	LO	LO
	16 10Hex									

The answer is an echo of the first two Byte (address and function), two Byte for first written parameter, two Byte with the N° of parameters, fixed to 1 (0001 Hex), two Byte for the CRC:

Address Unit	Function	Address of the First Parameter		N° of the Parameter		CRC 16	
		HI	LO	0	1	LO	HI
	16 10Hex						

## 12.5 Error and exception responses

If a message contains an altered character, if fails the CRC, or if the received message contains a syntax error (for example the number of the byte or of the words is not correct), then the unit will ignore the message.

If the received message is correct but contains a not valid value, the unit will send an answer of exception (5 byte):

Address Unit	Function	Error Code	CRC 16	
			LO	HI

The byte with the function number, represent the function number of the message that has caused the error with the first Bit set to 1 (ex. the function 3 becomes 0x83) The error code could be one of the followings:

Error Code	Name	Cause
1	ILLEGAL FUNCTION	Function not supported.
2	ILLEGAL DATA ADDRESS	Address out of range.
3	ILLEGAL DATA VALUE	Attempt to write invalid or action not carried out.



NOTE: If you write a parameter's value equal at his actual value this is a valid transaction and don't cause an error.



## 13 Configuration Parameters

The Configuration Parameters are accessible from the software configurator or through the serial communication port RS485.

<b>P001L (H01)</b>	<b>Byte Lo = Load Voltage</b>	<b>R</b>
Function:	This parameter show the Voltage rms value	
Min/Max:	0 ÷ 255 (0 ÷ FF Hex)	
Value:	Value depends on the Unit type	
<b>P001H (H01)</b>	<b>Byte Hi = Load Current</b>	<b>R</b>
Function:	This parameter shows the Current rms value.	
Min/Max:	0 ÷ 255 (0 ÷ FF Hex)	
Value:	Value depends on when turns have current transformer and from his size's.	
Example:	With one passage on the current transformer (CT) 25/0.05A, the max value corresponds to the max value of the CT: Read value=255 (FF Hex) -> Load Current= 25A	
<b>P002L (H02)</b>	<b>Byte Lo = Set-point Voltage</b>	<b>R/W</b>
Function:	This parameter is the Set-point voltage saved by the Calibration Procedure	
Min/Max:	0 ÷ 255 (0 ÷ FF Hex)	
<b>P002H (H02)</b>	<b>Byte Hi = Set-point Current</b>	<b>R/W</b>
Function:	This parameter is the Set-point of current below which HB alarm occurs	
Min/Max:	0 ÷ 255 (0 ÷ FF Hex)	
Value:	This value is the load current(P001H) minus % value of parameter P126H	
<b>P003 (H03)</b>	<b>Status Table</b>	<b>R</b>
Function:	It's a tab in bit that represent the "Status" of thyristor unit	
Value:	Bit 0 = 1 -> Short circuit on SCR Bit 1 = 1 -> Load Failure (HB Alarm) Bit 2 = 1 -> Output signal ON Bit 3 = 1 -> HB Calibration in progress Bit 4 = 1 -> Current Limit Flag Bit 5 = 1 -> Thermal switch	
<b>P004 (H04)</b>	<b>Command Table</b>	<b>R/W</b>
Function:	It's a tab in bit for remote commands via RS485	
Value:	Bit 0 = 1 -> Activate HB Calibration procedure Bit 1 = 1 -> Input Command from RS485 (see P005) Bit 2 = 1 -> Disable Output signal (Only with Input from RS485) Bit 3 = 1 -> Reset HB Alarm Bit 4 = 1 -> Current Limit via RS485 (see P007)	
Note:	When unit is switch off all command parameter are set to 0	
<b>P005L (H05)</b>	<b>Input command signal</b>	<b>R</b>
Function:	This parameter reads the Input command signal (see par. 7.4) When the P004 Bit1 =1 This parameter could be written and become the Input Command from RS485	
Min/Max:	0 ÷ 255 (0 ÷ FF Hex)	
Example:	Input 4mA -> P005L = 0 (0%) Input 12mA -> P005L = 128 (50%) Input 20mA -> P005L = 255 (100%)	
<b>P005H (H05)</b>	<b>Byte Hi = Ramped Input command signal</b>	<b>R</b>
Function:	This parameter reads the Input command signal after the ramp	
Min/Max:	0 ÷ 255 (0 ÷ FF Hex)	
Example:	Input 4mA -> P005H = 0 (0%) Input 12mA -> P005H = 128 (50%) Input 20mA -> P005H = 255 (100%)	

**P006 (H06)**

Function:

Min/Max:

Value:

Note:

**Power adjust**

Its' a scaling factor of the Input command signal

0 ÷ 255 (0 ÷ FF Hex)

from 0 = 0% of Output,

To 255 = 100% of Output.

This parameter limit the Output Power

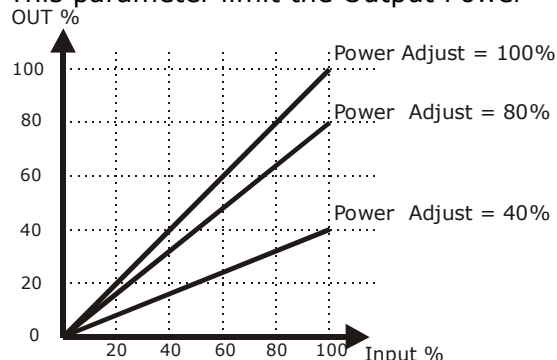
**R/W****P007 (H07)**

Function:

Min/Max:

Value:

Example:

**Current Limit**

This parameter show the Current Limit value (see par. 10.3)

When the P004 Bit4 =1 This parameter could be written and become the Current Limit from RS485

0 ÷ 255 (0 ÷ FF Hex)

Value depends on when turns have current transformer and from his size's With one passage on the current transformer (CT) 25/0.05A, the max value corresponds to the max value of the CT:

Read value=255 (FF Hex) -&gt; Load Current= 25A

**R****P121 (H79)**

Function:

Value:

**CD Unit ID**

This parameter Identify the CD type Family

CD32 Hex = CD3200 Family

**R****P122 (H7A)**

Function:

**CD Ver**

This parameter is for internal use

**R****P123 (H7B)**

Function:

Min/Max:

Value:

Note:

**Password**

This parameter give the access to configuration

0 ÷ FFFF Hex

9357 Hex = Writing parameters activated

any value = Writing parameters disabled

When the unit comes out and then re-lighted, for change the parameters you must re-insert the password.

**R/W****P124 (H7C)**

Function:

Min/Max:

Value:

**Actual power**

This parameter show the actual value of the power demand

0 ÷ 65535 (0 ÷ FFFF Hex)

from 0 = 0% output power,

to 65535 = 100% output power.

**R**

<b>P125L (H7D)</b>	<b>Byte Lo = Feed-Back Type</b>	<b>R/W</b>
Function:	This parameter set the Feed-Back Type	
Value:	00 Hex = V2 20 Hex = V 40 Hex = I 80 Hex = VxI	
Default:	20 (if not specified in the Order Code)	
<b>P125H (H7D)</b>	<b>Byte Hi = Soft start time</b>	<b>R/W</b>
Function:	The Unit starts in phase angle mode with a ramp starting from zero up to full voltage in a presetted and Adjustable time. The time is setted by this parameter	
Min/Max:	0 ÷ 255 (0 ÷ FF Hex)	
Value:	Each step is 50msec	
Default:	20 (S+PA)	
<b>P126L (H7E)</b>	<b>Byte Lo = HB Delay time</b>	<b>R/W</b>
Function:	This parameter set a delay to have HB alarm active	
Min/Max:	1 ÷ 255 (0 ÷ FF Hex)	
Value:	Each step is 50msec	
Default:	30 (if not specified in the Order Code)	
Note:	If Soft start option is enabled HB Delay time must be greater than Soft start time: P126L x 50msec > P125H x 50msec	
<b>P126H (H7E)</b>	<b>Byte Hi = HB sensibility</b>	<b>R/W</b>
Function:	This parameter is the maximum reduction of Load Current to establish the HB Alarm	
Min/Max:	0 ÷ 100 (0 ÷ 64 Hex)	
Value:	Each step is 1% from Nominal Current	
Default:	14 Hex	
Note:	When you change this parameter, HB Calibration procedure is necessary.	
<b>P127 (H7F)</b>	<b>Power Set</b>	<b>R/W</b>
Function:	This parameter show the Power set saved by the Calibration Procedure	
Min/Max:	0 ÷ 65535 (0 ÷ FFFF Hex)	
Value:	from 0 = 0% output power, to 65535 = 100% output power.	
<b>P128L (H80)</b>	<b>Byte Lo = Integral</b>	<b>R/W</b>
Function:	This parameter is the integral time of the feed-back loop	
Min/Max:	0 ÷ 255 (0 ÷ FF Hex)	
Default:	50 Hex	
Note:	If you increase integral time you increase the output stability, but you increase also the time to reach the set.	
<b>P128H (H80)</b>	<b>Byte Hi = Proportional</b>	<b>R/W</b>
Function:	This parameter is the gain of the feed-back loop	
Min/Max:	0 ÷ 255 (0 ÷ FF Hex)	
Default:	VxI or V2 = 5 Hex V or I = 12 Hex	
Note:	This parameter increase the loop speed but decrease the loop stability.	

## 14 FuseHolder and Fuses

CD3200 unit must be protected by fuses against short circuit selecting the proper  $I^2t$  that must be lower than the thyristor one ( $I^2t_{max}$ ).



**Caution:** USE ONLY EXTRARAPID FUSE WITH APPROPRIATE  $I^2t$

### 14.1 FuseHolder size

for size 15A - 25A

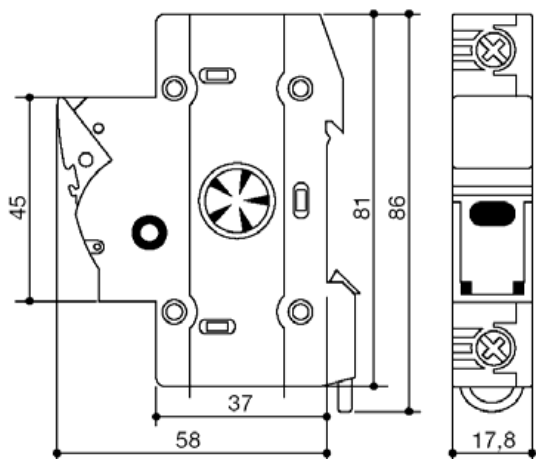

for size 35A - 45A

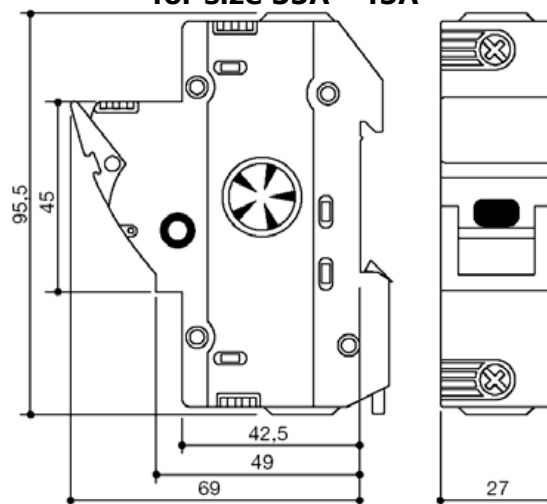

for size 60A - 90A(CE)

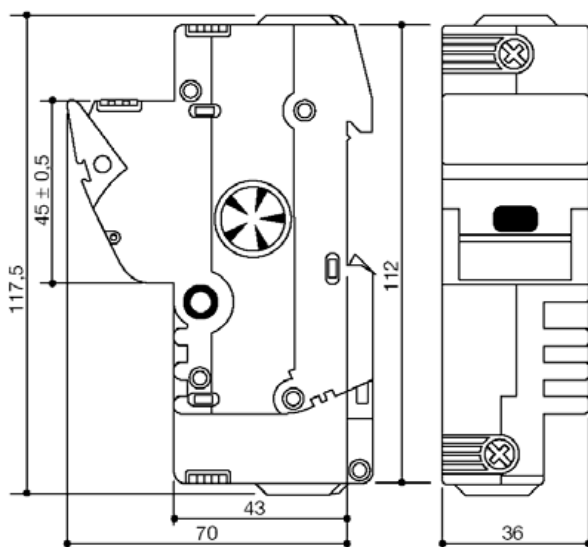

for size 90A(UL) - 110A

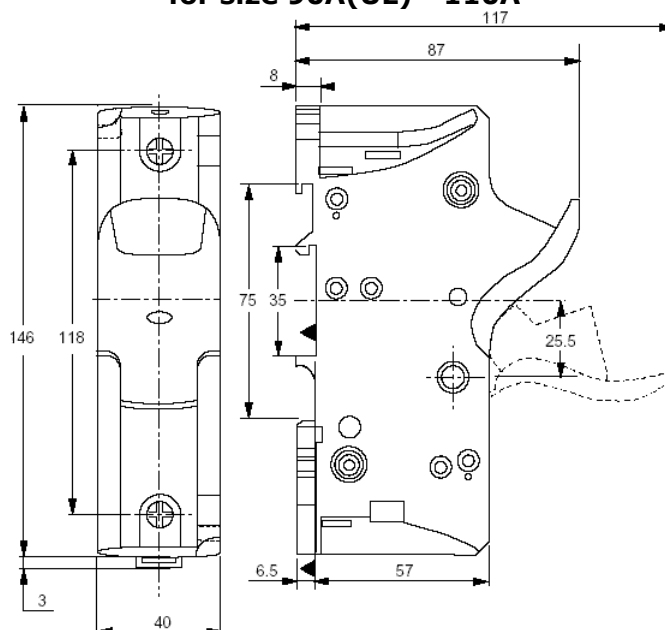

## 14.2 Fuses and Fuse Code for UL

SIZE	Bussmann Div Cooper (UK) Ltd (200 kARMS Symmetrical A.I.C.)				Ferraz Shawmut SA (200 kARMS Symmetrical A.I.C.)				Qty
	Fuse CODE	Current (ARMS)	I <sup>2</sup> T (A <sup>2</sup> sec)	Vac	Fuse CODE	Current (ARMS)	I <sup>2</sup> T (A <sup>2</sup> sec)	Vac	
15A	FWC 16A10F	16	150	600	660 Grb 10-16	16	145	660	1
25A	FWC 32A10F	32	600	600	660 Grb 10-32	32	740	660	1
35A	FWP 40A14F	40	750	700	CP URC 14x51/40	40	700	660	1
45A	FWP 50A14F	50	1800	700	CP URC 14x51/50	50	1500	660	1
60A	FWP 80A22F	80	6600	700	CP URD 22x58/80	80	3800	660	1
90A	-	-	-	-	CP URQ 27x60/125	125	6970	660	1
110A	-	-	-	-	CP URQ 27x60/160	160	15000	660	1



**Caution:** The Fuses must have I<sup>2</sup>t 20% less than thyristor's I<sup>2</sup>t.



**Caution:** High speed fuses are used only for the thyristor protection and can not be used to protect the installation.



**Caution:** The warranty of thyristor is null if no proper fuses are used. See tab.



**Warning:** The user installation must be protected by electromagnetic circuit breaker or by fuse isolator.



### 14.3 Fuses and Fuse Code for CE

SIZE	Fuse and Fuse holder CODE	Fuse CODE	Current (ARMS)	I <sup>2</sup> T (max) (A <sup>2</sup> sec.)
15A	FFH1038/16A	FU1038/16A	16	150
25A	FFH1038/32A	FU1038/32A	32	600
35A	FFH1451/40A	FU1451/40A	40	1650
45A	FFH1451/50A	FU1451/50A	50	2000
60A	FFH2258/80A	FU2258/80A	80	6550
90A	FFH2258/125A	FU2258/125A	125	14000
110A	FFH2760/160A	FU2760/160A	160	15000



**Caution:** The Fuses must have I<sup>2</sup>t 20% less than thyristor's I<sup>2</sup>t.



**Caution:** High speed fuses are used only for the thyristor protection and can not be used to protect the installation.



**Caution:** The warranty of thyristor is null if no proper fuses are used. See tab.



**Warning:** The user installation must be protected by electromagnetic circuit breaker or by fuse isolator.



# 15 Maintenance

## 15.1 Trouble Shooting

Small problems sometimes can be solved locally with the help of the below tab of trouble shooting. If you don't succeed, contact us or your nearest distributor.

Symptom	Indication on front unit	Possible reasons of the symptom	Actions
Thyristor unit doesn't go in conduction with input signal	Green LED (Aux) always light off	<ul style="list-style-type: none"> <li>No voltage auxiliary power</li> </ul>	<ul style="list-style-type: none"> <li>Give auxiliary voltage supply (see wiring diagram)</li> </ul>
	Green LED (Aux) light on Green LED (ON) light off	<ul style="list-style-type: none"> <li>No input signal</li> <li>Reversed polarities of input signal</li> <li>Reset contact is open</li> </ul>	<ul style="list-style-type: none"> <li>Provide to give input signal</li> <li>Reverse the input signal polarity</li> <li>Make link on reset terminals (see wiring diagram)</li> </ul>
	Green LED (Aux) light on Green LED (ON) light on	<ul style="list-style-type: none"> <li>Fuse failure</li> <li>Load failure</li> <li>Load connection interruption</li> <li>Thyristor faulty and always in open circuit</li> </ul> With HB option the yellow led (HB) is light on	<ul style="list-style-type: none"> <li>Substitute the fuse</li> <li>Check the load</li> <li>Check the wiring</li> <li>Substitute the faulty thyristor</li> </ul>
Load current flows also with no input signal	Green LED (ON) always light off.	<ul style="list-style-type: none"> <li>Wrong wiring</li> <li>Short circuit on thyristor</li> </ul> If there is HB option the red LED (SC) is light on	<ul style="list-style-type: none"> <li>Check the load wiring</li> <li>Substitute the thyristor</li> </ul>
Current flows at nominal value but Yellow LED (HB) is light on	Yellow LED (HB) light on	<ul style="list-style-type: none"> <li>HB circuit not tuned</li> <li>Current transformers not properly wired</li> </ul>	<ul style="list-style-type: none"> <li>Make HB calibration procedure</li> <li>Control current transformers wiring</li> </ul>
Current flows at nominal value but Red LED (SC) is light on	Red LED (SC) light on	<ul style="list-style-type: none"> <li>HB circuit not tuned</li> </ul>	<ul style="list-style-type: none"> <li>Make HB calibration procedure</li> </ul>
Thyristor unit doesn't work properly		<ul style="list-style-type: none"> <li>Wrong input signal selection.</li> <li>Wrong input signal calibration (out of range).</li> <li>Auxiliary voltage supply out of limits</li> </ul>	<ul style="list-style-type: none"> <li>Control input signal setting.</li> <li>Repeat input calibration procedure.</li> <li>Verify the auxiliary voltage supply</li> </ul>

## 15.2 Fans

The thyristor unit with forced ventilation uses fans that rotate permanently when the unit is supplied. In case of fan failure, the heat-sink can reach high temperature. In this case to give protection to thyristor there is a thermal switch properly setted. The function of this switch is to open the input signal until the heat-sink temperature falls below the setted value. This means that also with input signal in ON condition the unit is switched OFF and the system can not work at full power. For this reason is important to control periodically the fans status checking that are rotating.

## 15.3 Maintenance

For maintain a correct cooling, the consumer must clean the heat-sink and the protective grate of the fans. The frequency of these operations depends on the atmospheric local pollution. Check also that the screw of the power terminals and earth terminals are shut correctly (see Diagram of control connection).

## 15.4 Repairing procedure

- Phone to CD Automation.
- Explain to Service Engineer the problem because sometimes it can be solved with a phone call. If this is not possible, ship the unit to CD Automation or to your distributor.
- Write a fault description and give the name of your personnel to which refers.
- Use a rugged packaging to ship the unit.

## 15.5 Warranty condition

CD Automation gives a 12 months warranty to its products. The warranty is limited to repairing and parts substitution in our factory and does exclude products not properly used and fuses. Warranty does not include products with serial numbers deleted. The faulty product should be shipped to CD Automation at customer's cost and our Service will evaluate if product is under warranty terms. Substituted parts remain of CD Automation property.



## 16 Note

[Redacted content]

