

OPERATION MANUAL

FAULT LOOP IMPEDANCE METER

MZC-304

MZC-304

Measuring terminals



Start the measurement

Contact electrode

SET/SEL - enter the meter settings, select the numbers to change

Move/ select: Left/Right, Up/Down

Turn the meter on/off (to turn off keep the button depressed for a longer time) turn the display backlight on/off

ESC - return to the previous screen, exit the function

Validate

ROTARY FUNCTION SELECTOR

Select the measurement function:

- Z_{L-PE} **RCD** - fault loop impedance measurement in L-PE protected by a RCD
- Z_{L-PE} - fault loop impedance measurement in L-PE circuit
- Z_{L-N} Z_{L-L} - fault loop impedance measurement in L-N or L-L circuit
- U, f - voltage and frequency measurement
- R_{CONT} - resistance measurement of protective conductors and equipotential bondings
- R_x - low-voltage resistance measurement
- **MEM** - view and erase memory and data transmission



OPERATING MANUAL

FAULT LOOP IMPEDANCE METER MZC-304



**SONEL SA
ul. Wokulskiego 11
58-100 Świdnica**

Version 1.09 27.06.2014

CONTENTS

1	SAFETY	5
2	MEASUREMENTS	6
2.1	TURNING THE METER ON AND OFF, DISPLAY BACKLIGHT	6
2.2	SELECTION OF GENERAL MEASUREMENT PARAMETERS	6
2.3	REMEMBERING THE LAST MEASUREMENT RESULT	7
2.4	MEASUREMENT OF ALTERNATING VOLTAGE	7
2.5	MEASUREMENT OF VOLTAGE AND FREQUENCY	8
2.6	CHECKING CORRECTNESS OF PE (PROTECTIVE EARTH) CONNECTIONS	8
2.7	MEASUREMENT OF FAULT LOOP PARAMETERS	9
2.7.1	<i>Cable length selection.....</i>	<i>9</i>
2.7.2	<i>Prospective short-circuit current.....</i>	<i>10</i>
2.7.3	<i>Measurement of fault loop parameters in the L-N and L-L circuits</i>	<i>10</i>
2.7.4	<i>Measurement of fault loop parameters in the L-PE circuit</i>	<i>13</i>
2.7.5	<i>Measurement of short circuit loop impedance in L-PE circuit protected by a residual current device (RCD).....</i>	<i>14</i>
2.8	MEASUREMENT OF RESISTANCE TO EARTH.....	15
2.9	LOW-VOLTAGE RESISTANCE MEASUREMENT	16
2.9.1	<i>Measurement of continuity of protective conductors and equipotential bondings with ± 200 mA current</i>	<i>17</i>
2.9.2	<i>Low-current measurement of resistance</i>	<i>18</i>
2.9.3	<i>Compensation of test leads resistance - autozeroing.....</i>	<i>19</i>
3	MEMORY OF MEASUREMENT RESULT DATA.....	21
3.1	STORING THE MEASUREMENT RESULT DATA IN THE MEMORY	21
3.2	CHANGING THE CELL AND BANK NUMBER	23
3.3	VIEWING MEMORY DATA.....	23
3.4	DELETING MEMORY DATA.....	24
3.4.1	<i>Deleting bank data.....</i>	<i>24</i>
3.4.2	<i>Deleting the whole memory</i>	<i>25</i>
3.5	COMMUNICATION WITH A COMPUTER	26
3.5.1	<i>Computer connection accessories</i>	<i>26</i>
3.5.2	<i>Data transmission.....</i>	<i>26</i>
4	TROUBLESHOOTING.....	28
5	POWER SUPPLY OF THE METER.....	29
5.1	MONITORING OF THE POWER SUPPLY VOLTAGE.....	29
5.2	REPLACEMENT OF BATTERIES	29
5.3	GENERAL RULES OF USING THE NICKEL METAL HYDRIDE (NI-MH) BATTERIES	30
6	CLEANING AND MAINTENANCE.....	31

7	STORAGE	31
8	DISMANTLING AND DISPOSAL.....	31
9	TECHNICAL SPECIFICATIONS	32
9.1	BASIC DATA	32
9.2	ADDITIONAL INFORMATION	34
9.2.1	<i>Additional uncertainty according to IEC 61557-3 (Z)</i>	<i>35</i>
9.2.2	<i>Additional uncertainty according to IEC 61557-4 (R ±200mA).....</i>	<i>35</i>
10	EQUIPMENT	36
10.1	STANDARD EQUIPMENT.....	36
10.2	OPTIONAL ACCESSORIES	36
11	MANUFACTURER	38

1 Safety

The MZC-304 meter is designed for testing the protection against electric shock in the mains systems. The meter is used to make measurements which results determine the electrical installation safety level. Consequently, in order to ensure safe operation and correct measurement results, observe the following recommendations:

- Before you proceed to operate the meter, acquaint yourself thoroughly with the present manual and observe the safety regulations and recommendations of the manufacturer.
- Any application that differs from those specified in the present manual may cause damage of the instrument and a serious hazard to its user.
- The MZC-304 meters must be operated solely by appropriately qualified personnel with relevant certificates to perform measurements of electric installation. Operation of the instrument by unauthorized personnel may result in damage to the device and constitute a hazard to the user.
- Using this manual does not exclude the need to comply with occupational health and safety regulations and with other relevant fire regulations required during the performance of a particular type of work. Before starting the work with the device in special environments, e.g. potentially fire-risk/explosive environment, it is necessary to consult it with the person responsible for health and safety.
- It is unacceptable to operate the following:
 - ⇒ a damaged meter which is completely or partially out of order,
 - ⇒ leads with damaged insulation,
 - ⇒ a meter which has been stored too long in unsuitable conditions (for example is wet). When the meter is transferred from cold environment to warm and humid one, do not make measurements until the meter warms up to the ambient temperature (about 30 minutes).
- Remember that the **bat** message on the display means that the power supply voltage is too low and indicates the need to replace/ charge the batteries. The measurements performed with the meter with insufficient supply voltage have additional measuring errors which are impossible to be evaluated by the user and cannot be the basis to determine the correct protection of the tested installation.
- Do not leave the discharged batteries in the meter as they can leak and damage the instrument.
- Before starting the measurement, check if the leads are connected to correct measuring terminals.
- Never use the meters with open or only partially closed battery compartment cover and use only the power supplies specified in this manual.
- Repairs may be performed solely by an authorized service outlet.

NOTE

Use only standard and optional accessories intended for a given instrument which are listed in the "Equipment" section. Using other accessories may cause damage of the measuring terminal and additional measuring errors.

Note:

An attempt to install drivers in 64-bit Windows 8 may result in displaying "Installation failed" message.

Cause: Windows 8 by default blocks drivers without a digital signature.

Solution: Disable the driver signature enforcement in Windows.

Note:

Due to continuous development of the meter software, the display view for some functions may be a bit different from the view shown in this manual.

2 Measurements



WARNING:

During the fault loop measurements, the earthed parts and parts accessible in the electrical installation being tested must not be touched.

WARNING:

During a measurement, switching of the range switch is forbidden because it may damage the meter and pose a threat to the user.

2.1 Turning the meter on and off, display backlight

Briefly press the  button to turn on the meter. Press it for a longer time to turn it off (**OFF** is displayed). Press briefly the  button during meter operation to turn on/off the display and keypad backlight.

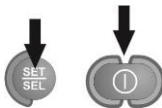

2.2 Selection of general measurement parameters

①



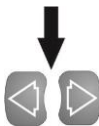

Keeping the **SET/SEL** button depressed, turn on the meter and wait for the parameter selection screen.

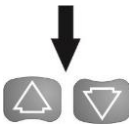

Use the   buttons to go to the next parameter.



Use the   buttons to change the parameter value. The value or symbol to be changed is flashing.

The **YES** symbol indicates an active parameter, the **NO** - symbol indicates an inactive one.

②

Set the parameters according to the following algorithm:

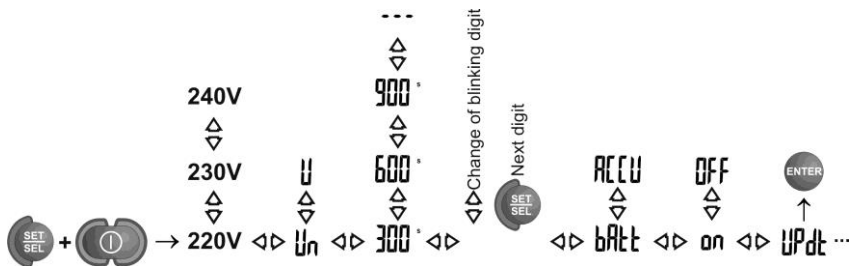

Parameter	Mains voltage	Voltage for calculating I_k : rated/measured	Auto-OFF	Change PIN	Supply source selection	Buzzer	Software updating
Symbol(s)	U_{L-N}	I_k	OFF	PIN	SUPP	BEEP	?

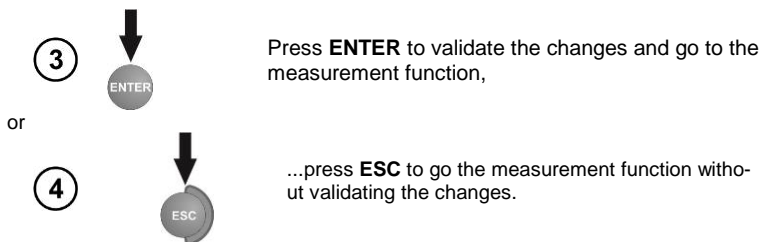

Note:

- Before the first measurements, select the mains rated voltage U_n (220/380V, 230/400V or 240/415V) used in the area where measurements are performed. This voltage value is used for calculating the values of prospective short-circuit current, if this option was chosen from the main menu.
- The --- symbol means that no auto-off time has been set.
- PIN settings - see section 3.5.2 **Data Transmission**.
- Use OR-1 receiver (section 3.5.1) to update the software. New software may be downloaded from www.sonel.pl.

2.3 Remembering the last measurement result

Result of the latest measurement is remembered by the meter until a next measurement is started, or measurement settings are changed, or the measuring function is changed by means of the rotary switch, or the meter is switched off. When you go to the output screen of a given function with the **ESC** button, you can recall this result by pressing **ENTER**. Similarly, you can view the latest measurement result after turning off and then turning on the meter.

2.4 Measurement of alternating voltage

The meter measures and displays alternating mains voltage in all measuring functions except R. This voltage is measured for the frequencies within the range of 45..65 Hz. The test leads should be connected as for a given measuring function.

2.5 Measurement of voltage and frequency

①

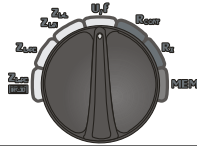

Set the rotary switch in the **U, f** position.

②



Read the result of measurement: the voltage on the secondary display field, the frequency on the principal.

2.6 Checking correctness of PE (protective earth) connections

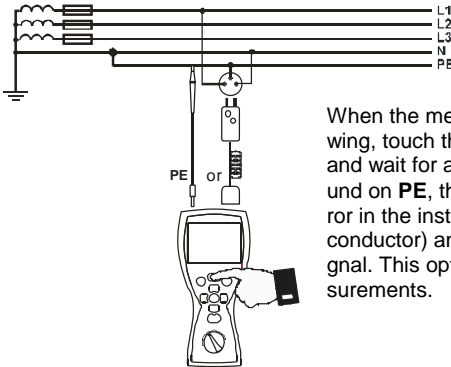

When the meter is connected as in the the drawing, touch the contact electrode with your finger and wait for about 1 second. When voltage if found on **PE**, the meter displays the **PE** symbol (error in the installation; PE connected to the phase conductor) and generates a continuous audio signal. This option is available for the **Z_{L-PE}** measurements.

Note:

WARNING:

When a dangerous voltage is detected on PE conductor, measurements must be immediately stopped and a fault in the installation must be removed.

- The person making a measurement must ensure that he/she is standing on a non-insulated floor during the measurement; otherwise the result of the measurement may be incorrect.
- The threshold value, which triggers the signal of exceeded allowable voltage on PE conduit, is approximately 50 V.

2.7 Measurement of fault loop parameters



If there are residual current devices in the tested network, they should be bypassed by bridging for the period of impedance measurement. However, it should be remembered that the tested circuit is modified in this way and the obtained results may slightly differ from the actual results.

Each time after completion of measurements, modifications introduced to the installation for the period of measurements should be removed and operation of the residual current device should be checked.

The above remark does not apply to measurements of fault loop impedance with the use of the Z_{L-PE} **RCD** function

2.7.1 Cable length selection

1

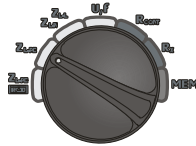

Turn the rotary switch to one of the loop impedance measurement ranges.

2

Set the parameters according to the following algorithm, and according to the rules described in general parameters setting.

NOTE: The WS-05 and WS-01 cables are detected by the meter and it is then impossible to select the cable length (the $\text{--}\bar{E}$ symbol is displayed). Using cables terminated with banana plugs, before starting to measure, select the appropriate length of the phase conductor, compatible with the length of cable used for measurement.

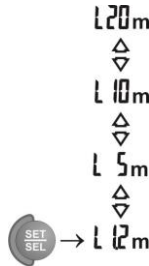

Note:



Using cables from known manufacturers and selecting the correct length guarantees the declared measurement accuracy.

2.7.2 Prospective short-circuit current

The meter always measures impedance. The short-circuit current is calculated according to the following formula:

$$I_k = \frac{U_n}{Z_s}$$

where: U_n - mains rated voltage, Z_s - measured impedance.

On the basis of U_n rated voltage selected (section 2.1), the meter automatically recognizes the measurement at phase-to-neutral or phase-to-phase voltage and takes it into account in the calculations.

If the voltage of the tested mains is outside the tolerance range, the meter will not be able to determine a proper rated voltage for the short-circuit current calculation. In such a case, horizontal dashes will be displayed instead a short-circuit current value. The following diagram shows voltage ranges for which short-circuit current value is calculated.

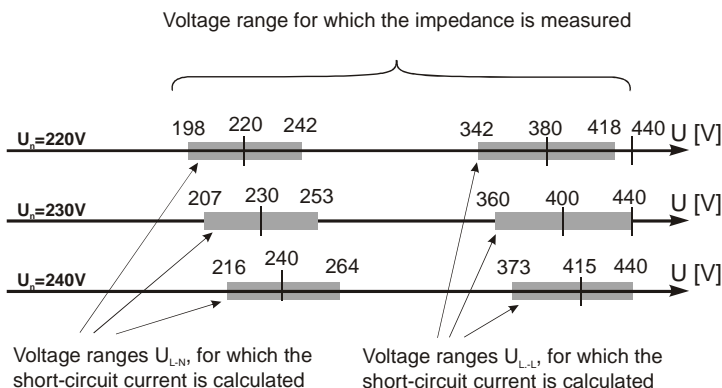

2.7.3 Measurement of fault loop parameters in the L-N and L-L circuits

- 1

Turn on the meter.
Turn the rotary switch to the Z_{L-L} Z_{L-N} position.
- 2

Depending on needs, select cable length according to section 2.7.1.

3

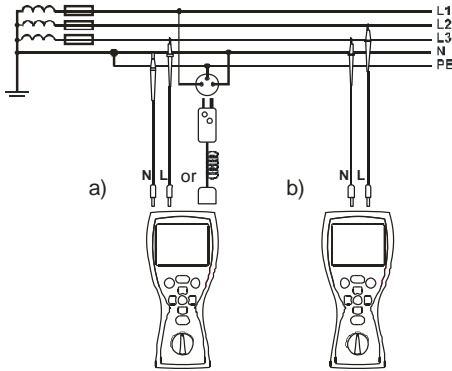

Connect test leads according to the drawing
 a) for measurement in the L-N circuit
 or
 b) for measurement in the L-L circuit

4

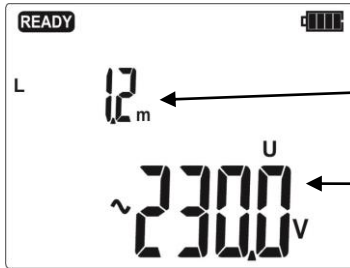

The meter is ready for measurement.

Phase conductor length or the $--E$ symbol.

U_{L-N} or U_{L-L} voltage

5



Make the measurement by pressing the **START** button.

6



Read the main measurement result: fault loop impedance Z_S and the mains voltage at the time of measurement.

7



To read additional results, press the  button.

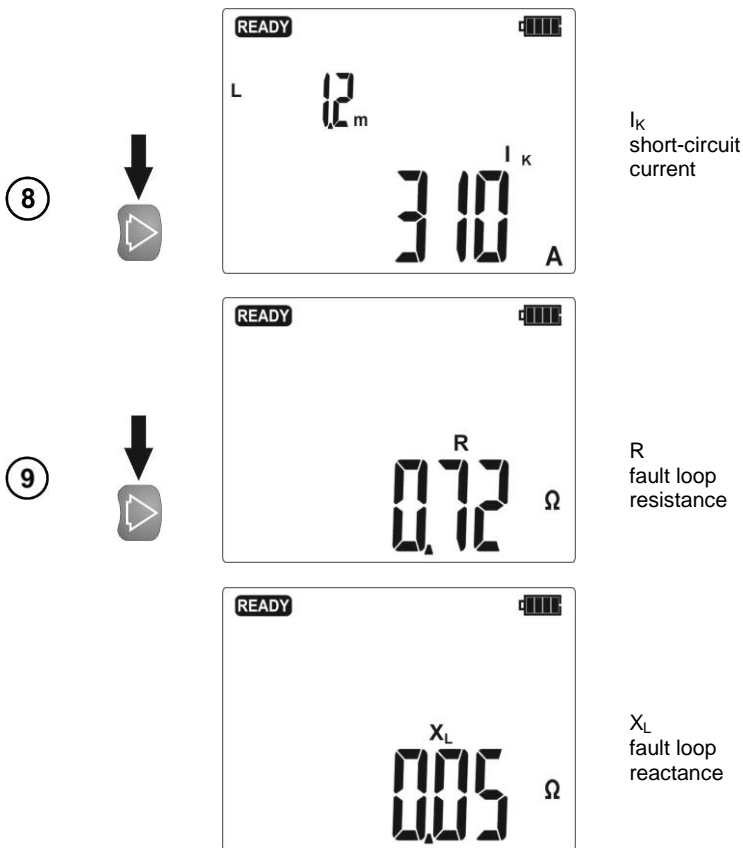



Note:

- Enter the result into memory (see sections 3.1 and 3.2) or press **ESC** to return to the voltage measurement.
- When many measurements are made at short time intervals, the meter may emit a large amount of heat. As a result of this, the enclosure of the device may become hot. This is normal and the meter is equipped with the protection against excessive temperature.
- Minimum interval between successive measurements is 5 seconds. This is controlled by the meter which displays the **READY** message informing that the measurement can be made.

Additional information displayed by the meter

READY	The meter is ready for measurement.
L-N	Voltage on terminals L and N is outside the measurable range.
L-PE	Voltage on terminals L and PE is outside the measurable range.
Err	Error during the measurement.

$ErrU$	Error during the measurement – voltage dip after the measurement.
$E00$	Short circuit malfunction.
ULn	Conductor N is not connected.
NOISE!	Huge noise in the system during the measurement. The measurement result may be affected by a large, unspecified error.
	The temperature inside the meter has risen above the limit. The measurement is blocked.
	The L and N conductors have been switched (voltage between terminals PE and N).

2.7.4 Measurement of fault loop parameters in the L-PE circuit

1

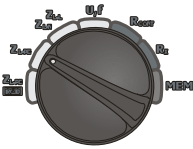

Turn on the meter.
Turn the rotary switch to the **Z_{L-PE}** position.

2

Depending on needs, select cable length according to section 2.7.1.

3

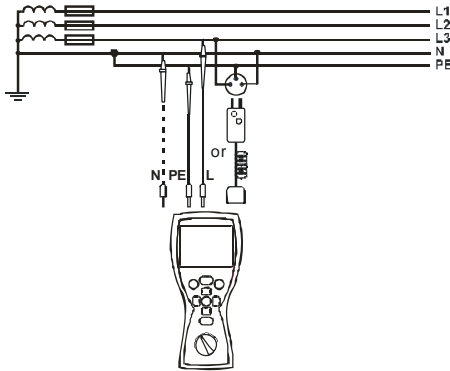

Connect the test leads according to one of the drawings.

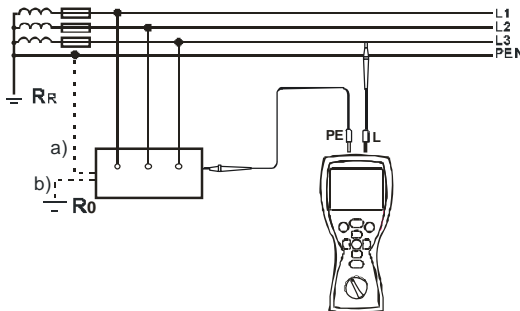

Checking effectiveness of protection against electric shock of the enclosure in case of: a) TN b) TT.

4

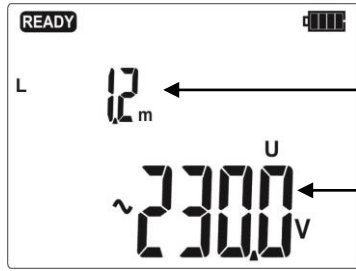

The meter is ready for measurement.

Phase conductor length or the $\sim E$ symbol.

U_{L-PE} voltage

5



Make measurement by pressing the **START** button.

Remaining issues connected with the measurements are the same as those described for measurements in L-N circuit or L-L circuit.

Note:

Double lead measurement is possible when a test lead other than the lead with a mains socket is selected.

Additional information displayed by the meter

Error messages and information - as for the L-N and L-L measurement.

2.7.5 Measurement of short circuit loop impedance in L-PE circuit protected by a residual current device (RCD)

The MZC-304 enables the fault loop impedance measurements without altering the mains protected by RCD's with the rated current of at least 30mA.

1

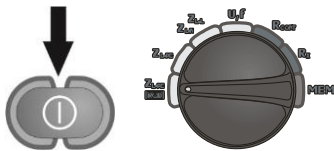

Turn on the meter.
Turn the rotary switch to the **Z_{L-PE} RCD** position

2

Depending on needs, select the measurement parameters according to section 2.7.1.

3

Connect the test leads according to one of the drawings.

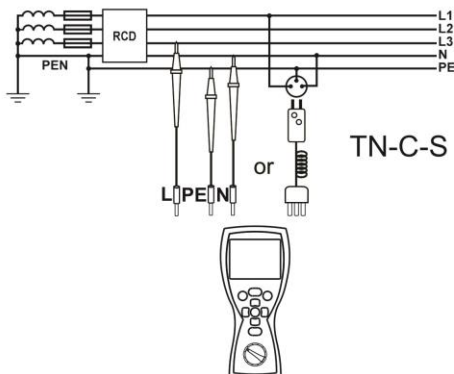
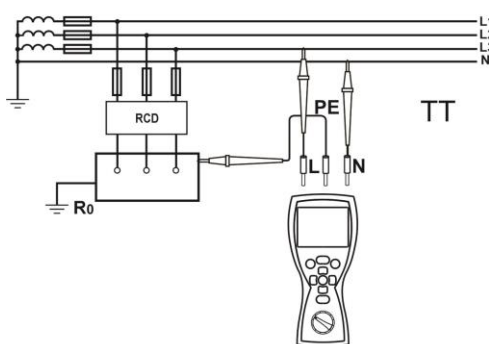
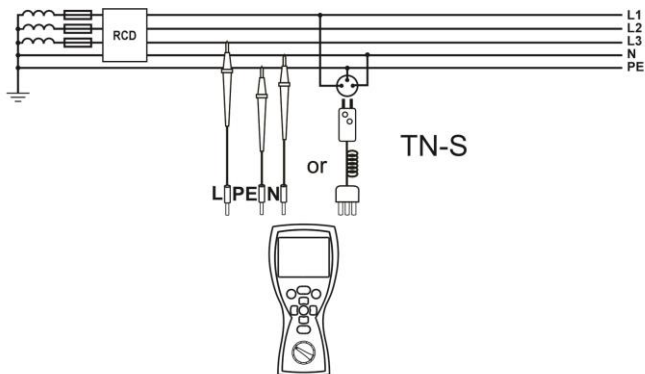

Remaining issues connected with the measurements are the same as those described for measurements of the L-PE circuit.

Note:

- Maximum measurement time is about 32 seconds. The measurement can be interrupted by pressing the **ESC** button.

In the electrical installations with 30 mA RCD's the sum of leakage currents of the installation and the test current may trip the RCD. If this happens, try to reduce the leakage current in the tested mains (for example by disconnecting loads).

Additional information displayed by the meter

Error messages and information - as for the L-N and L-L measurement.

2.8 Measurement of resistance to earth

The MPI-502 meter can be used for approximate measurements of resistance to earth. For this purpose, the phase conductor is used as a secondary source of voltage which generates test current. Connection diagram for the instrument for such measurement in the TN-C, TN-S and TT systems is shown in the figure below.

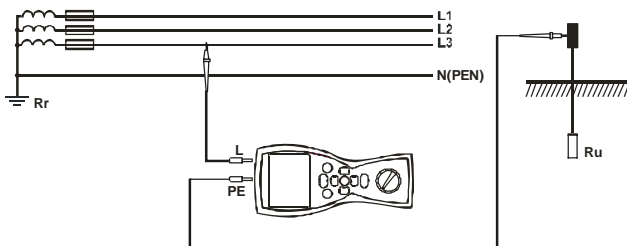

During the measurement, check the connections of the measured earth electrode with the electrical installation. For correct measurement, the tested earthing system should be disconnected from the electrical installation (N and PE conductors). If you want to measure the earth electrode, for instance in the TN-C-S system and simultaneously use the phase of the same system as a secondary source of current, disconnect the PE and N conductors from the measured earth electrode (see figure below). Otherwise, the meter will measure an incorrect value (the test current will flow not only through the measured earthing system).

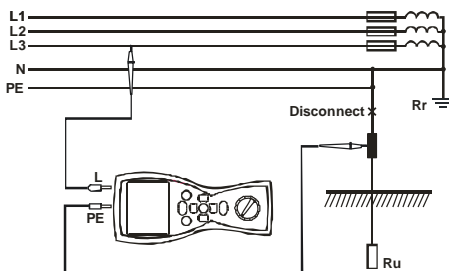

Note:

WARNING:

Disconnection of protective conductors is a serious life hazard for the staff performing the measurements and also third parties. When the measurements are completed, the protective and neutral conductors MUST be reconnected.

- If it is not possible to disconnect the conductors, use an earth resistance meter from the MRU range.
- As the measurement result is the sum of impedances of the measured earth electrode, working earthing system, source and phase conductor, it contains a positive error. However, if such error does not exceed a limit value for the tested earthing system, it can be concluded that the earthing has been made correctly and there is no need for a more accurate measurement methods.

2.9 Low-voltage resistance measurement



The meter can be damaged if connected to the voltage exceeding 500V.

2.9.1 Measurement of continuity of protective conductors and equipotential bondings with ± 200 mA current

1

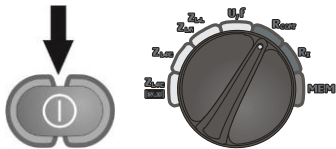

Turn on the meter.
Turn the rotary switch
to the R_{CONT} position.

2

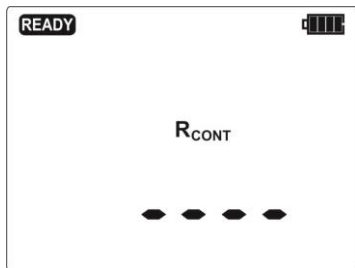

The meter is ready
for measurement.

3

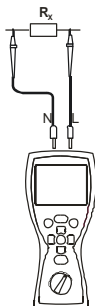

Connect test leads according to the drawing.

4



Activate the measurement by pressing
the **START** button. The measurement
starts automatically for resistances lower
than 30Ω

5

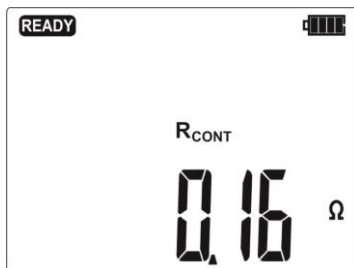

Read the measurement
result which is the arithmetic
mean of two measurements
with 200mA current
flowing in opposite directions.

Additional information displayed by the meter

UDET	The tested facility is live. The measurement is blocked. Immediately disconnect the meter from the facility (both conductors)!
NOISE!	Huge noise in the system during the measurement. The measurement result may be affected by a large, unspecified error.
> 400 Ω	Measuring range is exceeded.

2.9.2 Low-current measurement of resistance

1

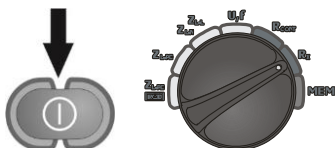

Turn on the meter.
Turn the rotary switch
to the R_x position.

2

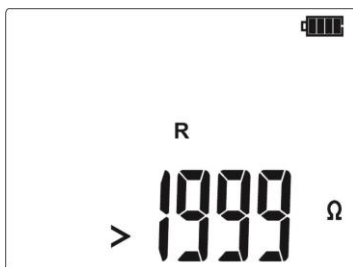

The meter is ready
for measurement.

3

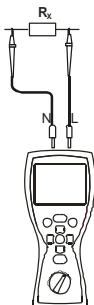

Connect test leads according to the drawing.

4



Read the measurement result.

Additional information displayed by the meter

UdEt	The tested facility is live. The measurement is blocked. Immediately disconnect the meter from the facility (both conductors)!
NOISE!	Huge noise in the system during the measurement. The measurement result may be affected by a large, unspecified error.
> 1999 °	Measuring range is exceeded.

2.9.3 Compensation of test leads resistance - autozeroing

1

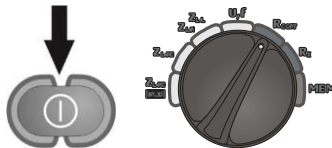

Turn on the meter.
Turn the rotary switch to the R_{CONT} or R_X position

2

Set the autozeroing according to the following algorithm.



3



Short the test leads.

4



Activate the autozeroing by pressing the **START** button.

5

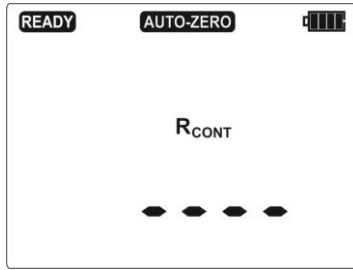

After completion of auto-zeroing, the meter automatically switches to the "ready for measurement" mode.

Note:

- The **AUTO-ZERO** message remains on the display after switching into one of the measurement functions (resistance or continuity measurement) indicating that the measurement is made with compensated least leads resistance.
- To remove the compensation, perform the above-mentioned activities but with open test leads. When you enter the measurement screen, the **AUTO-ZERO** message will not be displayed.

Additional information displayed by the meter

	The tested facility is live. The measurement is blocked. Immediately disconnect the meter from the facility (both conductors)!
---	---

3 Memory of measurement result data

MZC-304 meters are equipped with the memory that can store 10000 single measurement results. The whole memory is divided into 10 memory banks, each of them containing 99 memory cells. Thanks to dynamic memory allocation, each of the memory cells can contain different quantity of single measurement results, depending on the needs. Optimal use of the memory can be ensured in this way. Each measurement result can be stored in a memory cell marked with a selected number and in a selected memory bank. Thanks to this, the user of the meter can, at his/her discretion, assign memory cell numbers to individual measurement points and the memory bank numbers to individual facilities. The user can also perform measurements in any sequence and repeat them without losing other data.

Memory of measurement result data **is not deleted** when the meter is switched off. Thanks to this, the data can be later read or sent to a computer. The number of a current memory cell or memory bank is not changed either.

Note:

- Results of measurements performed for all measuring functions can be stored in one memory cell.
- After each entry of the measurement result to the cell, its number is automatically incremented. Set the appropriate cell number to allow entering to a single cell of successive measurement results relating to a given measuring point (facility).
- Only the results of measurements activated by pressing the **START** button can be stored in the memory (except autozeroing in low-voltage resistance measurement).
- It is recommended to delete the memory after reading the data or before performing a new series of measurements that may be stored in the same memory cells as the previous ones.

3.1 Storing the measurement result data in the memory

①



Press **ENTER** after completion of the measurement.
The meter is in the memory storing mode.

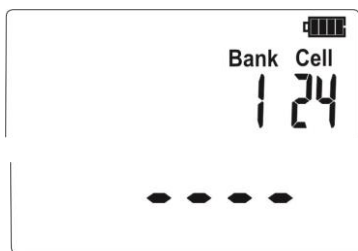

Cell is empty.



The cell contains the result of the same type which is to be entered.

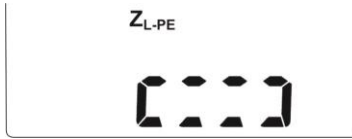

The cell contains the measurement results of the displayed types.

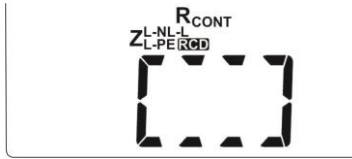

The cell contains the measurement results of all types.

2

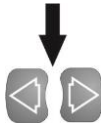

Use ◀ the ▶ buttons to view different types of results and their components.

3



Select the bank and cell number (see section 3.2) or leave the current number. Then press **ENTER** again. The following screen appears for a moment, accompanied by three short beeps, and then the meter returns to display the last measurement result.

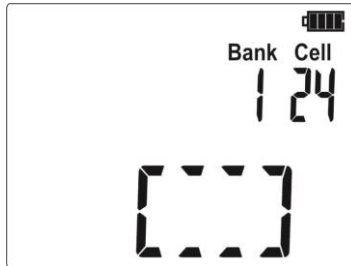

4

An attempt to overwrite causes the warning symbol to appear.



5

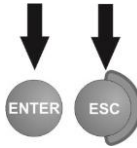

Press **ENTER** to overwrite the result or **ESC** to abort.

Note:

- Complete set of results (main result and supplementary results) for a given measuring function and measurement settings are stored in the memory.

3.2 Changing the cell and bank number

1



Press **ENTER** after completion of the measurement.
The meter is in the memory storing mode.

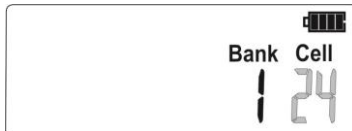

The cell number is flashing.

To change, use the \blacktriangle and \blacktriangledown buttons.

2



Press **SET/SEL**.

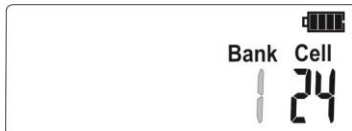

The bank number is flashing.

To change, use the \blacktriangle and \blacktriangledown buttons.

3



Press **SET/SEL**.
The cell number is flashing again.

3.3 Viewing memory data

1

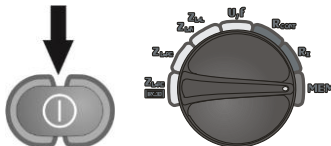

Turn on the meter.
Turn the rotary switch to the **MEM** position.



The content of the last saved cell appears.

The cell number is flashing.

Use the **SET/SEL** buttons and then the Δ ∇ buttons to change the number of the bank and cell which intent you want to view. If the bank or cell number is flashing, its number can be changed.

②

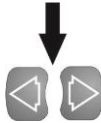

Use the \triangleleft and \triangleright buttons to view different types of results and their components.

3.4 Deleting memory data

3.4.1 Deleting bank data

①

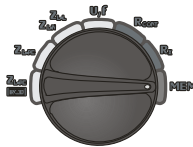

Turn on the meter.
Turn the rotary switch to the **MEM** position.

②

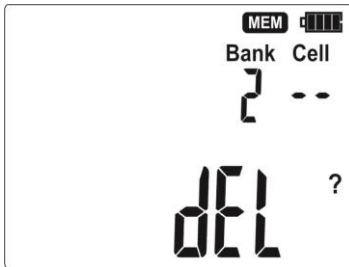

Set the bank number to be deleted according to section 3.2.
Set the cell number to -- (before 1). The **del** symbol appears which indicates the readiness to delete.

③



Press **ENTER**.

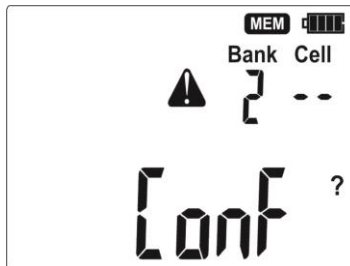

The **Conf** and $\triangle!$ symbols appear, asking you to confirm deletion.

4



Press **ENTER** to start deleting or **ESC** to abort.

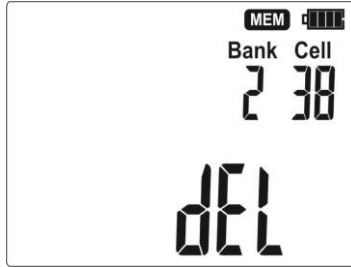

The deletion progress is shown on the display as scrolling cell numbers. When deletion is complete, the meter generates three short beeps and sets the cell number to 1.

3.4.2 Deleting the whole memory

1

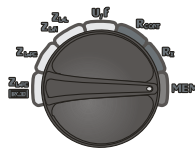

Turn on the meter.
Turn the rotary switch to the **MEM** position.

2

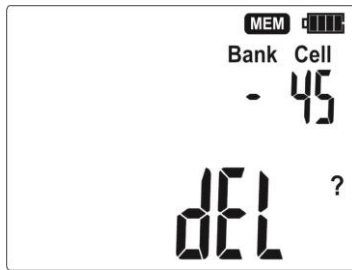

Set the bank number to **-** (before 0). The symbol **DEL** appears which indicates the readiness to delete.

3



Press **ENTER**.

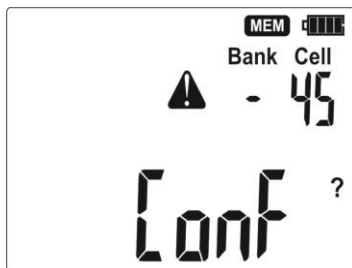

The **Conf** and **!** symbols appear, asking you to confirm deletion.

4



Press **ENTER** to start deleting or **ESC** to abort.

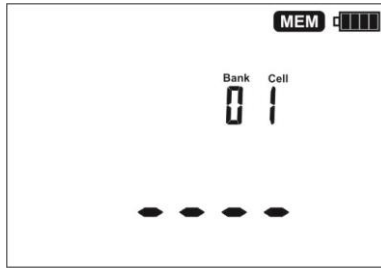

The deletion progress is shown on the display as scrolling bank and cell numbers. When deletion is complete, the meter generates three short beeps and sets the cell number to 1.

3.5 Communication with a computer

3.5.1 Computer connection accessories

What is necessary in order to operate the meter with a computer is additional accessories, namely an OR-1 receiver and appropriate software. If this package has not been purchased along with the meter, it can be bought from the manufacturer or an authorized distributor where detailed software information is also available.

3.5.2 Data transmission

①

Connect the OR-1 module to the USB socket of the PC.

②

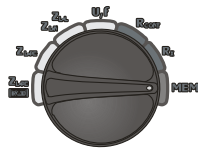

Turn on the meter.
Turn the rotary switch to the **MEM** position.

③



Press **SET/SEL** for about 2 seconds; the meter will ask you to activate the radio transmission.



④



Press **ENTER**, the radio transmission screen will appear.

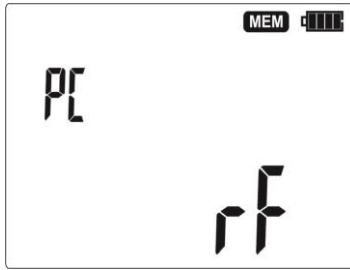

To transmit data, follow the instructions of the software.
Press **ESC** to exit the transmission mode.

Note:



Standard pin for OR-1 is the „123”. Settings in the meter according to section 2.2.

4 Troubleshooting

Before returning the instrument for repair, call the service, perhaps the meter is not damaged and the problem has occurred for another reason.

The meter repairs should be carried out only in the outlets authorized by the manufacturer.

The following table describes the recommended procedure in certain situations that occur when using the meter.

Measuring function	Symptom	Cause	Action
All	The meter will not start after pressing the ⓘ button. The bat symbol is displayed during the voltage measurement. Meter turns off during the initial test.	Discharged or incorrectly placed batteries/rechargeable batteries	Check if the batteries are placed correctly, replace and/or recharge the batteries. If this does not help, send the meter for servicing.
	Measurement errors after moving the meter from cold environment to warm and humid environment.	No acclimatization	Do not perform the measurements until the meter reaches the ambient temperature (about 30 minutes) and dries.
Fault loop	Successive results obtained in the same measuring point are significantly different from each other	Incorrect connections in the tested mains.	Check the connections and remove defects
		Mains with high noise or unstable voltage	Perform a larger number of measurements, average the results
	The meter indicates the values close to zero or zero irrespective of the location of the measurement and these values are significantly different than expected.	Incorrectly selected test leads in the meter settings.	
	The PE symbol does not appear, although the voltage between the contact electrode and the PE conductor exceeds the detector threshold (about 50V)	Contact electrode is not functioning correctly or the meter input circuits are damaged	Return the meter for servicing; the use of a malfunctioning meter is unacceptable
Rotary switch in a wrong position.		Contact electrode is active for the measurements of the Z_{L-PE} fault loop parameters.	

5 Power supply of the meter

5.1 Monitoring of the power supply voltage

The charge level of the batteries or rechargeable batteries is indicated by the symbol in the right upper corner of the display on a current basis:

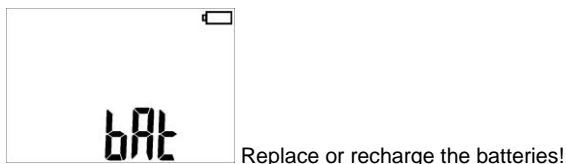
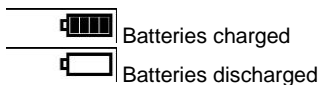

Note:

- The **bat** symbol in the display means that the supply voltage is too low and indicates that the batteries must be replaced or recharged,
- Measurements performed with an insufficient supply voltage feature additional errors which the user is unable to evaluate.

5.2 Replacement of batteries

The MZC-304 is powered by four LR6 batteries or AA size rechargeable batteries. They are placed in the compartment at the bottom of the enclosure.

WARNING:
Before replacing the batteries, disconnect the test leads from the meter.

To replace the batteries:

1. Disconnect the leads from the measuring circuit and turn off the meter;
2. Remove the screw that secures the battery cover (the bottom of the enclosure);
3. Replace all batteries. Observe the correct polarity when putting new batteries ("- on the elastic part of the contact plate). Reversed polarity will not damage the meter or the batteries, but the meter will not work;
4. Place and tighten the battery compartment cover.

NOTE!
After replacing the batteries, always set the power supply type in the main MENU. The correct charge indication depends on this setting (the discharge characteristics of disposable and rechargeable batteries are different).

NOTE!
Have the meter serviced in case of battery leakage inside the compartment.

Batteries must be recharged in an external charger.

5.3 General rules of using the Nickel Metal Hydride (Ni-MH) batteries

- If you are not going to use the instrument for a longer time, remove the rechargeable batteries and store them separately.
- Store the rechargeable batteries in a dry, cool and well ventilated place and protect them from direct sunlight. The long storage temperature should be below 30 degrees C. If the batteries are stored long at high temperatures, the chemical processes may reduce their life.
- The NiMH rechargeable batteries usually withstand 500-1000 charging cycles. Such batteries achieve full capacity after forming (2-3 discharging and charging cycles). The most important factor which influences the battery life is the discharge level. The deeper the discharge level, the shorter the battery life.
- The memory effect appears in the NiMH batteries in a limited scope. These batteries can be recharged without more serious consequences. It is, however, recommended to discharge them completely every few cycles.
- During the storage of the Ni-MH rechargeable batteries, they are subject to self-discharge process at the rate of about 30% a month. Keeping the batteries at high temperatures may accelerate this process even two times. In order not to allow an excessive discharging of the batteries (after which the forming will be needed), recharge the batteries once in a while (even unused batteries).
- Modern, fast chargers detect too low and too high temperature of the batteries and respond accordingly. If the temperature is too low, the charging process should not start as it might irrevocably damage a rechargeable battery. The battery temperature increase is a signal to stop the charging and is typical. In addition to faster temperature increase of a battery which will not be fully charged, charging at high ambient temperatures results, however, in a reduced life.
- Remember that with fast charging, the batteries are charged to about 80% of their capacity; better results can be achieved by continuing the charging process: the charger then goes into the small current charging mode and after a few hours the batteries are fully charged.
- Do not charge and do not use the batteries at extreme temperatures as they reduce the life of batteries. Avoid using the battery-powered devices in very hot places. The rated operating temperature must be observed at all times.

6 Cleaning and maintenance

NOTE!

Use only the maintenance methods presented by the manufacturer in this manual.

Clean the meter casing and the case with a wet cloth, using generally available detergents. Do not use any solvents and cleaning media which could scratch the casing (powder, paste, etc.).

The probes can be cleaned with water and then wiped dry. Before longer storage, it is recommended to lubricate the probes with any machine grease.

Clean the spools and leads with water and detergents, then wipe dry.

The meter electronic system is maintenance free.

7 Storage

When storing the instrument, observe the following recommendations:

- disconnect all leads from the meter,
- thoroughly clean the meter and all accessories,
- wind long test leads onto the spools,
- if you are not going to use the instrument for a longer time, remove the batteries,
- during a prolonged storage recharge the batteries from time to time to prevent total discharging.

8 Dismantling and disposal

Used electric and electronic equipment should be collected selectively, i.e. not placed with other types of waste.

Used electronic equipment shall be sent to the collection point according to the Used Electric and Electronic Equipment Act.

Before sending the instrument to the collection point, do not dismantle any parts by yourself.

Observe local regulations on disposal of packagings and used batteries.

9 Technical specifications

9.1 Basic data

⇒ Abbreviation "m.v." used in the specification of measurement uncertainty means a standard measured value.

Voltage measurement

Range	Resolution	Measurement uncertainty
0.0...299.9V	0,1V	±(2% m.v. + 6 digits)
300...500V	1V	±(2% m.v. + 2 digits)

- Frequency range: 45...65Hz

Frequency measurement

Range	Resolution	Measurement uncertainty
45.0...65.0Hz	0,1Hz	±(0.1% m.v. + 1 digit)

- Voltage range: 50 .. 500V

Measurement of fault loop impedance Z_{L-PE} , Z_{L-N} , Z_{L-L}

Measurement of fault loop impedance Z_s

Test range according to IEC 61557:

Test lead	Measurement range Z_s
1,2m	0.13...1999 Ω
5m	0.17...1999 Ω
10m	0.21...1999 Ω
20m	0.29...1999 Ω
WS-01, -05	0.19...1999 Ω

Display range:

Display range	Resolution	Measurement uncertainty
0.00...19.99 Ω	0,01 Ω	±(5% m.v. + 3 digits)
20.0...199.9 Ω	0,1 Ω	±(5% m.v. + 3 digits)
200...1999 Ω	1 Ω	±(5% m.v. + 3 digits)

- Rated operating voltage U_{nL-N} / U_{nL-L} : 220/380V, 230/400V, 240/415V
- Operating voltage range: 180...270V (for Z_{L-PE} i Z_{L-N}) and 180...460V (for Z_{L-L})
- Rated mains frequency f_n : 50Hz, 60Hz
- Operating frequency range: 45...65Hz
- Maximum test current: 7.6 A for 230 (3x10ms), 13.3 A for 400V (3x10ms)
- Control of correctness of PE terminal connection by means of a contact electrode (applicable to Z_{L-PE})

Fault loop resistance R_s and fault loop reactance X_s

Display range	Resolution	Measurement uncertainty
0.00...19.99 Ω	0.01 Ω	±(5% + 5 digits) of Z_s value
20.0...199.9 Ω	0.1 Ω	±(5% + 5 digits) of Z_s value

- Calculated and displayed for $Z_S < 20\Omega$

Short-circuit current I_k

Test range according to IEC 61557 can be calculated on the basis of test ranges Z_S and rated voltages.

Display range	Resolution	Measurement uncertainty
0.110...1.999A	0.001 A	Calculated on the basis of uncertainty for fault loop
2.00...19.99A	0.01 A	
20.0...199.9A	0.1 A	
200...1999A	1 A	
2.00...19.99kA	0.01 kA	
20.0...40.0kA	0.1 kA	

- Prospective fault current calculated and displayed by the meter may slightly differ from the value calculated by the user with a calculator, basing on the displayed value of the impedance, because the meter calculates the current from unrounded value of fault loop impedance (which is used for displaying). As the correct value, consider I_k current value, displayed by the meter or by firmware.

Measurement of fault loop impedance Z_{L-PE} **RCD** (without RCD tripping)

Measurement of fault loop impedance Z_S

Measuring range acc. to IEC 61557: 0,5...1999 Ω for 1.2m leads, WS01 i WS05 and 0.51...1999 Ω for 5m, 10m and 20m leads

Display range	Resolution	Measurement uncertainty
0.00...19.99 Ω	0,01 Ω	$\pm(6\% \text{ m.v.} + 10 \text{ digits})$
20.0...199.9 Ω	0,1 Ω	$\pm(6\% \text{ m.v.} + 5 \text{ digits})$
200...1999 Ω	1 Ω	$\pm(6\% \text{ m.v.} + 5 \text{ digits})$

- It will not trip RCD's of $I_{\Delta n} \geq 30 \text{ mA}$
- Rated operating voltage U_n : 220V, 230V, 240V
- Operating voltage range: 180...270V
- Rated mains frequency f_n : 50Hz, 60Hz
- Operating frequency range: 45...65Hz
- Control of correctness of PE terminal connection by means of a contact electrode

Fault loop resistance R_S and fault loop reactance X_S

Display range	Resolution	Measurement uncertainty
0.00...19.99 Ω	0.01 Ω	$\pm(6\% + 10 \text{ digits})$ of Z_S value
20.0...199.9 Ω	0.1 Ω	$\pm(6\% + 5 \text{ digits})$ of Z_S value

- Calculated and displayed for $Z_S < 20\Omega$

Short-circuit current I_k

Test range according to IEC 61557 can be calculated on the basis of test ranges Z_S and rated voltages.

Display range	Resolution	Measurement uncertainty
0.110...1.999A	0.001 A	Calculated on the basis of uncertainty for fault loop
2.00...19.99A	0.01 A	
20.0...199.9A	0.1 A	
200...1999A	1 A	
2.00...19.99kA	0.01 kA	
20.0...24.0kA	0.1 kA	

- Prospective fault current calculated and displayed by the meter may slightly differ from the value calculated by the user with a calculator, basing on the displayed value of the impedance, because the meter calculates the current from unrounded value of fault loop impedance (which is used for displaying). As the correct value, consider I_k current value, displayed by the meter or by firmware.

Low-voltage continuity and resistance measurement

Measurement of continuity of protective conductors and equipotential bondings with ± 200 mA current

Measurement range according to IEC 61557-4: Ω

Range	Resolution	Measurement uncertainty
0.00...19.99 Ω	0.01 Ω	$\pm(2\% \text{ m.v.} + 3 \text{ digits})$
20.0...199.9 Ω	0.1 Ω	
200...400 Ω	1 Ω	

- Voltage at open terminals: 4...9V
- Output current at $R < 2\Omega$: min 200mA (I_{SC} : 200...250mA)
- Compensation of test leads resistance
- Measurements for both current polarizations

Low-current resistance measurement

Range	Resolution	Measurement uncertainty
0.0...199.9 Ω	0.1 Ω	$\pm(3\% \text{ m.v.} + 3 \text{ digits})$
200...1999 Ω	1 Ω	

- Voltage at open terminals: 4...9V
- Short-circuit current I_{SC} : 8...15mA
- Audio signal for measured resistance $< 30\Omega \pm 50\%$
- Compensation of test leads resistance

Other technical specification

- a) type of insulation double, EN 61010-1 and IEC 61557 compliant
- b) measurement category IV 300V (III 600V), EN 61010-1 compliant
- c) degree of protection of enclosure acc. to EN 60529 IP67
- d) meter power supply LR6 alkaline batteries or NiMH rechargeable batteries size AA (4 pcs)
- e) dimensions 220x98x58 mm
- f) meter weight about 1 kg
- g) storage temperature $-20...+70^{\circ}\text{C}$
- h) operating temperature $0...+50^{\circ}\text{C}$
- i) humidity 20...80%
- j) reference temperature $+23 \pm 2^{\circ}\text{C}$
- k) reference humidity 40...60%
- l) altitude (above sea level) < 2000 m
- m) time to Auto-OFF 120 seconds
- n) number of measurements Z (for rechargeable batteries) > 5000 (2 measurements per minute)
- o) display LCD segment
- p) memory of measurement results 990 cells, 10000 entries
- q) data transmission radio link, waveband ISM 433 MHz
- r) quality standard development, design and manufacturing are ISO 9001 compliant
- s) the device meets the requirements of the IEC 61557 standard
- t) the product meets the EMC requirements (immunity for industrial environment) according to the following standards EN 61326-1:2006 and EN 61326-2-2:2006

9.2 Additional information

Information about additional uncertainty is useful mainly when the meter is used in untypical conditions and for the measurements laboratories during calibration.

9.2.1 Additional uncertainty according to IEC 61557-3 (Z)

Influencing value	Designation	Additional uncertainty
Location	E ₁	0%
Supply voltage	E ₂	0% (BAT is not displayed)
Temperature 0...35°C	E ₃	1.2m lead – 0Ω 5m lead – 0.011Ω 10m lead – 0.019Ω 20m lead – 0.035Ω WS-01, WS-05 leads – 0.015Ω
Phase angle 0..30° at the bottom of measurement range	E _{6,2}	0,6%
Frequency 99%..101%	E ₇	0%
Mains voltage 85%..110%	E ₈	0%
Harmonics	E ₉	0%
DC component	E ₁₀	0%

9.2.2 Additional uncertainty according to IEC 61557-4 (R ±200mA)

Influencing value	Designation	Additional uncertainty
Location	E ₁	0%
Supply voltage	E ₂	0,5% (BAT is not displayed)
Temperature 0...35°C	E ₃	1,5%

10 Equipment

10.1 Standard equipment

Standard set of equipment supplied by the manufacturer includes:

- MZC-304 meter – **WMPLMZC304**
- set of test leads:
 - adapter WS-05 with angle plug UNI-SCHUKO (CAT III 300V) – **WAADAWS05**
 - leads 1,2m (CAT III 1000V) with banana plugs – 3 pcs (yellow **WAPRZ1X2YEBB**, red-**WAPRZ1X2REBB** and blue - **WAPRZ1X2BUBB**)
- accessories
 - crocodile clip (CAT III 1000V) – 1 pc. (yellow K02 – **WAKROYE20K02**)
 - test prod with banana socket (CAT II 1000V) – 2 pcs. (red- **WASONREOGB1** and blue – **WASONBUOGB1**)
- adapter - the receiver for radio transmission OR-1 – **WAADAUSBOR1**
- rigid hanger with a hook – **WAPOZUCH1**
- carrying case for the meter and accessories – **WAFUTM6**
- meter harness – **WAPOZSZE4**
- SONEL CD
- OPERATING MANUAL
- warranty card
- calibration certificate
- 4 LR6 batteries

10.2 Optional accessories

Additionally, the following items that are not included in the scope of standard equipment can be purchased from the manufacturer or the distributors:

WAPRZ005REBB



- 5m lead, red

WAPRZ020REBB



- 20m lead, red

WAPRZ010REBB



- 10m lead, red

WAADAWS01



- WS-01 adapter for triggering the measurement with the UNI-Schuko plug

WASONYEOGB1



- test prod with banana socket

WAADAAGT16P - five-wire version WAADAAGT16C - four-wire version



- AGT-16P adapter for three-phase sockets

WAADAAGT63P - five-wire version



- AGT-63P adapter for three-phase sockets

WAPROSCHEM

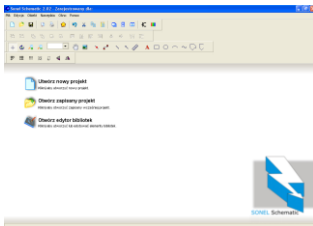

- SONEL Schematic software for creating drawings, electrical installation diagrams

WAKRORE20K02



- crocodile, red

WAADAAGT32P - five-wire version WAADAAGT32C - four-wire version



- AGT-32P adapter for three-phase sockets

WAPROSONPE4



- SONEL Electrical Measurements software for measurement reports

WAPROKALK

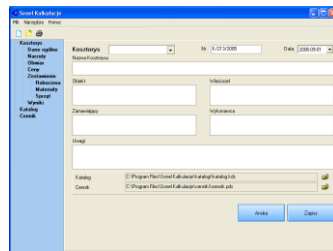

- SONEL Calculations software for measurement calculations

WAADAKEY1



- *adapter – USB dongle for the software*

LSWPLMZC304

- *calibration certificate*

Note

The software is supported by the following systems: Windows XP (Service Pack 2), Windows Vista, Windows 7.

11 Manufacturer

The manufacturer of the device and provider of warranty and post-warranty service:

SONEL S.A.

ul. Wokulskiego 11
58-100 Świdnica
Poland

tel. +48 74 858 38 60

fax +48 74 858 38 09

E-mail: export@sonel.pl

Web page: www.sonel.pl

NOTE

Service repairs must be performed solely by the manufacturer.



MPI-525
Multifunction Electrical
Installations Meter



MPI-505
Multifunction
Electrical
Installations
Meter



MPI-502
Multifunction
Electrical
Installations
Meter



MRU-200
Earth Resistance
and Resistivity Meter

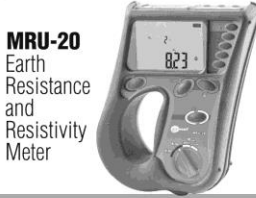

MRU-20
Earth
Resistance
and
Resistivity
Meter



MIC-2510
Insulation
Resistance
Meter

MIC-2
Insulation
Resistance
Meter



KT-384
Thermal
imager

MIC-30
Insulation
Resistance
Meter

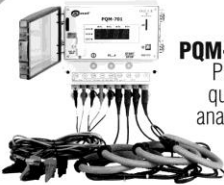

PQM-701
Power
quality
analyzer

LXP-1
Datalogging
Light
Meter



PAT-805
Portable
appliance
tester



CMM-40
Industrial
multimeter



CMP-1006
Digital
Clamp-on
multimeter



MMR-630
Microohmmeters



CMP-200
Digital
Clamp-on
AC



DIT-500
IR thermometer



LKZ-700
Wire tracer















NOTES

WARNINGS AND GENERAL INFORMATION DISPLAYED BY THE METER

NOTE!

MZC-304 meter is designed for operation at the 220V, 230V and 240V rated phase-to-neutral voltage and the 380V, 400V and 415V phase-to-phase voltage. Connecting the voltage higher than allowed between any measuring terminals may damage the meter and be a hazard to the user.

	The meter is ready for measurement.
	Voltage on terminals L and N is outside the measurable range.
	Voltage on terminals L and PE is outside the measurable range.
	Error during the measurement.
	Error during the measurement: voltage dip after the measurement.
	Short circuit malfunction.
	Conductor N is not connected.
	Huge noise in the system during the measurement. The measurement result may be affected by a large, unspecified error.
	The temperature inside the meter has risen above the limit. The measurement is blocked.
	The L and N conductors have been switched (voltage between terminals PE and N).
	The tested facility is live. The measurement is blocked. Immediately disconnect the meter from the facility (both conductors).
	Indication of battery level: Batteries charged Batteries low Batteries fully discharged. Replace or recharge the batteries.



SONEL S.A.
Wokulskiego 11, St
58-100 Swidnica
Poland



+48 74 85 83 860
+48 74 85 83 800
fax +48 74 85 83 808

<http://www.sonel.pl>
e-mail: export@sonel.pl