



*See the possibilities*

# *User's Manual*

## ***CM-030GE***

## ***CB-030GE***

### ***CM-030GE-RA***

### ***CB-030GE-RA***

*Digital Monochrome / Color  
Progressive Scan GigE Vision Camera*

Document Version: 2.0  
CMB-030GE\_Ver.2.0\_Aug2011

---

## **Notice**

The material contained in this manual consists of information that is proprietary to JAI Ltd., Japan and may only be used by the purchasers of the product. JAI Ltd., Japan makes no warranty for the use of its product and assumes no responsibility for any errors which may appear or for damages resulting from the use of the information contained herein. JAI Ltd., Japan reserves the right to make changes without notice.

Company and product names mentioned in this manual are trademarks or registered trademarks of their respective owners.

## **Warranty**

For information about the warranty, please contact your factory representative.

## **Certifications**

### **CE compliance**

As defined by the Directive 2004/108/EC of the European Parliament and of the Council, EMC (Electromagnetic compatibility), JAI Ltd., Japan declares that CM-030GE, CB-030GE, CM-030GE-RA and CB-030GE-RA comply with the following provisions applying to its standards.

EN 61000-6-3 (Generic emission standard part 1)

EN 61000-6-2 (Generic immunity standard part 1)

### **FCC**

This equipment has been tested and found to comply with the limits for a Class B digital device, pursuant to Part 15 of the FCC Rules. These limits are designed to provide reasonable protection against harmful interference in a residential installation. This equipment generates, uses and can radiate radio frequency energy and, if not installed and used in accordance with the instructions, may cause harmful interference to radio communications. However, there is no guarantee that interference will not occur in a particular installation. If this equipment does cause harmful interference to radio or television reception, which can be determined by turning the equipment off and on, the user is encouraged to try to correct the interference by one or more of the following measures:

- Reorient or relocate the receiving antenna.
- Increase the separation between the equipment and receiver.
- Connect the equipment into an outlet on a circuit different from that to which the receiver is connected.
- Consult the dealer or an experienced radio/TV technician for help.

### **Warning**

**Changes or modifications to this unit not expressly approved by the party responsible for FCC compliance could void the user's authority to operate the equipment.**

## Supplement

The following statement is related to the regulation on " Measures for the Administration of the control of Pollution by Electronic Information Products ", known as " China RoHS ". The table shows contained Hazardous Substances in this camera.

 mark shows that the environment-friendly use period of contained Hazardous Substances is 15 years.

### 重要注意事项

#### 有毒，有害物质或元素名称及含量表

根据中华人民共和国信息产业部『电子信息产品污染控制管理办法』，本产品《有毒，有害物质或元素名称及含量表》如下。

部件名称	有毒有害物质或元素					
	铅 (Pb)	汞 (Hg)	镉 (Cd)	六价铬 (Cr(VI))	多溴联苯 (PPB)	多溴二苯醚 (PBDE)
螺丝固定座	×	○	○	○	○	○
连接插头	×	○	○	○	○	○
电路板	×	○	○	○	○	○
.....	.....	.....	.....	.....	.....	.....

○：表示该有毒有害物质在该部件所有均质材料中的含量均在SJ/T11363-2006规定的限量要求以下。  
 ×：表示该有毒有害物质至少在该部件的某一均质材料中的含量超出SJ/T11363-2006规定的限量要求。  
 (企业可在此处、根据实际情况对上表中打“×”的技术原因进行进一步说明。)



#### 环保使用期限

电子信息产品中含有的有毒有害物质或元素在正常使用的条件下不会发生外泄或突变、电子信息产品用户使用该电子信息产品不会对环境造成严重污染或对基人身、财产造成严重损害的期限。

数字「15」为期限15年。

## Supplement

The following statement is related to the regulation on “ Measures for the Administration of the control of Pollution by Electronic Information Products ” , known as “ China RoHS ” . The table shows contained Hazardous Substances in this camera.

 mark shows that the environment-friendly use period of contained Hazardous Substances is 15 years.

### 重要注意事项

#### 有毒，有害物质或元素名称及含量表

根据中华人民共和国信息产业部『电子信息产品污染控制管理办法』，本产品《有毒，有害物质或元素名称及含量表》如下。

部件名称	有毒有害物质或元素					
	铅 (Pb)	汞 (Hg)	镉 (Cd)	六价铬 (Cr(VI))	多溴联苯 (PPB)	多溴二苯醚 (PBDE)
螺丝固定座	×	○	○	○	○	○
光学滤色镜	×	○	×	○	○	○
连接插头	×	○	○	○	○	○
电路板	×	○	○	○	○	○
.....	.....	.....	.....	.....	.....	.....

○：表示该有毒有害物质在该部件所有均质材料中的含量均在SJ/T11363-2006规定的限量要求以下。  
 ×：表示该有毒有害物质至少在该部件的某一均质材料中的含量超出SJ/T11363-2006规定的限量要求。  
 (企业可在此处、根据实际情况对上表中打“×”的技术原因进行进一步说明。)



#### 环保使用期限

电子信息产品中含有的有毒有害物质或元素在正常使用的条件下不会发生外泄或突变、电子信息产品用户使用该电子信息产品不会对环境造成严重污染或对基人身、财产造成严重损害的期限。

数字「15」为期限15年。

Table of Contents

1.	General .....	- 6 -
2.	Camera nomenclature .....	- 6 -
3.	Main Features .....	- 7 -
4.	Locations and Functions .....	- 8 -
5.	Pin Assignment.....	- 11 -
5.1	12-pin Multi-connector (DC-in/GPIO/Iris Video) .....	- 11 -
5.2	Digital Output Connector for Gigabit Ethernet .....	- 11 -
6.	GPIO (General purpose inputs and outputs) .....	- 12 -
6.1	Overview .....	- 12 -
6.1.1	LUT (Look Up Table) .....	- 12 -
6.1.2	12-bit Counter.....	- 13 -
6.1.3	Pulse Generators (0 to 3)..... エラー! ブックマークが定義されていません。	
6.2	Opto-isolated Inputs/Outputs .....	- 14 -
6.2.1	Recommended External Input circuit diagram for customer.....	- 15 -
6.2.2	Recommended External Output circuit diagram for customer .....	- 15 -
6.2.3	Optical Interface Specifications.....	- 16 -
6.3	Inputs and outputs table .....	- 16 -
6.4	Configuring the GPIO module (register settings) .... エラー! ブックマークが定義されていません。	
6.4.1	Input/Output Signal Selector .....	エラー! ブックマークが定義されていません。
6.4.2	12-bit counter .....	エラー! ブックマークが定義されていません。
6.4.3	Pulse generators (20-bit x 4) .....	エラー! ブックマークが定義されていません。
6.5	GPIO programming examples..... エラー! ブックマークが定義されていません。	
6.5.1	GPIO Plus PWC shutter.....	エラー! ブックマークが定義されていません。
6.5.2	Internal Trigger Generator.....	- 19 -
7.	GigE Vision Streaming Protocol (GVSP).....	- 20 -
7.1	Digital Video Output (Bit Allocation) .....	- 21 -
7.2	Bit Allocation (Pixel Format / Pixel Type) - CM-030GE/CM-030GE-RA.....	- 21 -
7.2.1	GVSP_PIX_MONO8 (8bit) .....	- 21 -
7.2.2	GVSP_PIX_MONO10 (10bit) .....	- 21 -
7.2.3	GVSP_PIX_MONO10_PACKED (10 bit) .....	- 22 -
7.3	Bit Allocation (Pixel Format / Pixel Type) - CB-030GE/CB-030GE-RA.....	- 22 -
7.3.1	GVSP_PIX_BAYRG8 “BayreRG8 “ .....	- 22 -
7.3.2	GVSP_PIX_BAYRG10 “Bayer RG10” .....	- 22 -
7.3.3	GVSP_PIX_BAYGB8 “BayerGB8” .....	- 22 -
7.3.4	GVSP_PIX_BAYGB10 “BayerGB10” .....	- 22 -
8.	Functions and Operations .....	エラー! ブックマークが定義されていません。
8.1	GigE Vision Standard Interface.....	- 28 -
8.2	Recommended Network Configurations .....	エラー! ブックマークが定義されていません。
8.2.1	Verified Network Interface Cards (NICs).....	エラー! ブックマークが定義されていません。
8.2.2	Video data rate (network bandwidth) .....	- 30 -
8.2.3	Disable Firewalls .....	エラー! ブックマークが定義されていません。
8.2.4	Enabling Jumbo Frame.....	エラー! ブックマークが定義されていません。
8.2.5	Setting Receive Descriptors.....	エラー! ブックマークが定義されていません。
8.2.6	Interrupt Moderation rate.....	エラー! ブックマークが定義されていません。
8.2.7	Calculating and setting Inter-Packet Delay ....	エラー! ブックマークが定義されていません。
8.2.8	Confirm the Filter Driver is used.....	エラー! ブックマークが定義されていません。
8.2.9	Other settings .....	エラー! ブックマークが定義されていません。
8.2.10	Note for 100BASE-TX connection .....	- 31 -
8.3	Basic functions .....	- 35 -
8.2.3	Vertical Binning (CM-030GE/CM-030GE-RA only).....	- 20 -
8.2.4	CB-030GE/CB-030GE-RA. Bayer filter .....	- 23 -
8.2.5	Electronic Shutter .....	- 35 -

8.2.6	Auto Iris Lens video output (12-pin Hirose connector).....	- 27 -
8.2.7	Auto-detect LVAL-sync / a-sync. accumulation .....	- 36 -
8.2.8	Rear panel indicator .....	- 10 -
8.3	Sensor Layout and timing .....	エラー! ブックマークが定義されていません。
8.3.1	CCD Sensor Layout.....	エラー! ブックマークが定義されていません。
8.3.2	Horizontal timing .....	- 24 -
8.3.3	Vertical timing .....	- 24 -
8.3.4	Partial Scanning.....	- 25 -
8.3.5	Vertical binning .....	- 26 -
8.4	Operation Modes.....	エラー! ブックマークが定義されていません。
8.4.1	Continuous operation .....	- 40 -
8.4.2	Pre-select Trigger Mode .....	- 41 -
8.4.3	Pulse Width trigger mode .....	- 43 -
8.4.4	Reset Continuous (RCT) trigger mode .....	- 45 -
8.4.5	Sequential Trigger Mode (Pre-Select trigger) .....	- 46 -
8.4.6	Delayed Readout Mode (Pre-Select, Pulse width control) .....	- 48 -
8.4.7	Optical Black transfer mode.....	- 48 -
8.5	Operation Mode and Functions matrix.....	- 50 -
9.	Register Map .....	エラー! ブックマークが定義されていません。
10.	External Appearance and Dimensions .....	- 60 -
11.	Specifications .....	- 62 -
11.1	Spectral response.....	- 62 -
11.2	Specification table .....	- 63 -
12.	Appendix.....	- 65 -
12.1	Precautions.....	- 65 -
12.2	Typical Sensor Characteristics.....	- 65 -
12.3	Caution when mounting a lens on the camera.....	- 65 -
12.4.	Caution when mounting the camera.....	- 66 -
12.5	Exportation.....	- 66 -
12.6	References .....	- 66 -
	Change History .....	- 67 -
	User's Record .....	- 68 -

## 1. JAI GigE<sup>®</sup> Vision Camera operation manuals

To understand and operate this JAI GigE<sup>®</sup> Vision camera properly, JAI provides the following manuals.

User's manual (this booklet)	Describes functions and operation of the hardware
JAI SDK & Control Tool User Guide	Describes functions and operation of the Control Tool
JAI SDK Getting Started Guide	Describes the network interface

User's manual is available at [www.jai.com](http://www.jai.com)

JAI SDK & Control Tool User Guide and JAI SDK Getting Started Guide are provided with the JAI SDK which is available at [www.jai.com](http://www.jai.com).

## 2. Introduction

GigE Vision is a standard interface which uses Gigabit Ethernet for machine vision applications. It was developed primarily by AIA (Automated Imaging Association) members. GigE Vision is capable of transmitting large amounts of uncompressed image data through an inexpensive general purpose LAN cable over long distances.

GigE Vision also supports the GenICam<sup>™</sup> standard which is maintained by the EMVA (European Machine Vision Association). The purpose of the GenICam standard is to provide a common program interface for various machine vision cameras. By using GenICam, cameras from different manufactures can seamlessly connect in one platform.

For details about the GigE Vision standard, please visit the AIA web site, [www.machinevisiononline.org](http://www.machinevisiononline.org) and for GenICam, the EMVA web site, [www.genicam.org](http://www.genicam.org).

JAI GigE Vision cameras comply with both the GigE Vision standard and the GenICam standard.

## 3. Before using GigE Vision cameras

All software products described in this manual pertain to the proper use of JAI GigE Vision cameras. Product names mentioned in this manual are used only for the explanation of operation. Registered trademarks or trademarks belong to their manufacturers.

To use the JAI SDK, it is necessary to accept the "Software license agreement" first.

This manual describes necessary equipment and the details of camera functions.

## 4. Software installation

The JAI GigE Vision SDK & Control Tool can be downloaded from the JAI web site at [www.jai.com](http://www.jai.com). The JAI SDK is available for Windows XP and Vista, 32-bit and 64-bit.

For the details of software installation, please refer to the "Getting Started Guide" supplied on the JAI SDK download page.

## Camera operation

### 1. General

*This manual covers the digital monochrome progressive scan camera CM-030GE/CM-030GE-RA and color progressive scan camera CB-030GE/CB-030GE-RA*

The CM-030GE/CM-030GE-RA/CB-030GE/CB-030GE-RA are a new additions to JAI GigE Vision compliant camera series. Both the monochrome version CM-030GE/CM-030GE-RA and the color version CB-030GE/CB-030GE-RA provide a frame rate of 90.5 frames/second at full resolution. Using vertical binning (CM-030GE/CM-030GE-RA only) and partial scan provides higher frame rates.

The 1/3" CCD with square pixels offers a superb image quality. The high-speed shutter function and asynchronous random trigger mode allow the camera to capture high quality images of fast moving objects.

The color version CB-030GE/CB-030GE-RA, based on CCD sensor with primary RGB Bayer mosaic filter, outputs raw Bayer images. Host-based color interpolation is required to display or save color images.

The CM-030GE/CM-030GE-RA/CB-030GE/CB-030GE-RA also comply with the GenICam standard and contains an internal XML-file that is used to describe the functions/features of the camera. For further information about GigE<sup>®</sup>Vision standard, please go to [www.machinevisiononline.org](http://www.machinevisiononline.org) and about GenICam<sup>™</sup>, please go to [www.emva.org](http://www.emva.org).

As an application programming interface, JAI provides an SDK (Software Development Kit). This SDK includes GigE Vision Filter Driver, JAI control tool, software documentation and code examples.

The JAI SDK can be downloaded from [www.jai.com](http://www.jai.com).

The latest version of this manual can be downloaded from [www.jai.com](http://www.jai.com)

For camera revision history, please contact your local JAI distributor.

### 2. Camera nomenclature

The standard camera composition consists of the camera main body and C-mount protection cap.

The camera is available in the following versions:

#### CM-030GE/CM-030GE-RA

Where **C** stands for "Compact" family, **M** stands for "Monochrome", **030** represents the resolution "300 thousand pixel", **\_GE** stands for "GigE Vision" interface and **RA** stands for Right Angle type

#### CB-030GE/CB-030GE-RA

Where **C** stands for "Compact" family, **B** stands for "Bayer mosaic color", **030** represents the resolution "300 thousand pixel" , **\_GE** stands for "GigE Vision" interface and **RA** stands for Right Angle type.





### 3. Main Features

- Member of Compact series, covering VGA to UXGA resolution
- 656 (h) x 494 (v) 7.4  $\mu$ m square pixels
- 1/3" progressive scan - monochrome and Bayer mosaic color versions
- High frame rate of 90.5 frames/second with full resolution in continuous operation
- 90 frames/second with external trigger and full resolution
- +24dB Gain and noise reduction circuit built-in
- Increased frame rate with vertical binning (CM-030GE/CM-030GE-RA only) and partial scan
- Exposure time from 43.2  $\mu$ s to 2 sec. using Pulse Width Control trigger mode
- Programmable exposure from 43.2 $\mu$ s to 11.037 ms in Full Frame scan
- Sequencer trigger mode for on-the-fly change of gain, exposure and ROI
- Edge Pre-select and Pulse width trigger mode
- LVAL-synchronous/-asynchronous operation (auto-detect)
- Auto iris lens video output allows a wider range of light
- GigE Vision Interface with 10 or 8-bit output
- Programmable GPIO with opto-isolated inputs and outputs
- Can be connected with 100BASE-TX
- Right Angle type is available as CM-030GE-RA and CB-030GE-RA
- Comprehensive software tools and SDK for Windows XP/Vista

**Note:** CM/CB-030GE and CM/CB-030GE-RA can be connected with 100BASE-TX. However, due to the limited bandwidth (100Mbps), the described specifications such as frame rate, minimum trigger interval and so on cannot be satisfied for 100BASE-TX connection.

## 4. Locations and Functions

### 4.1. CM-030GE and CB-030GE

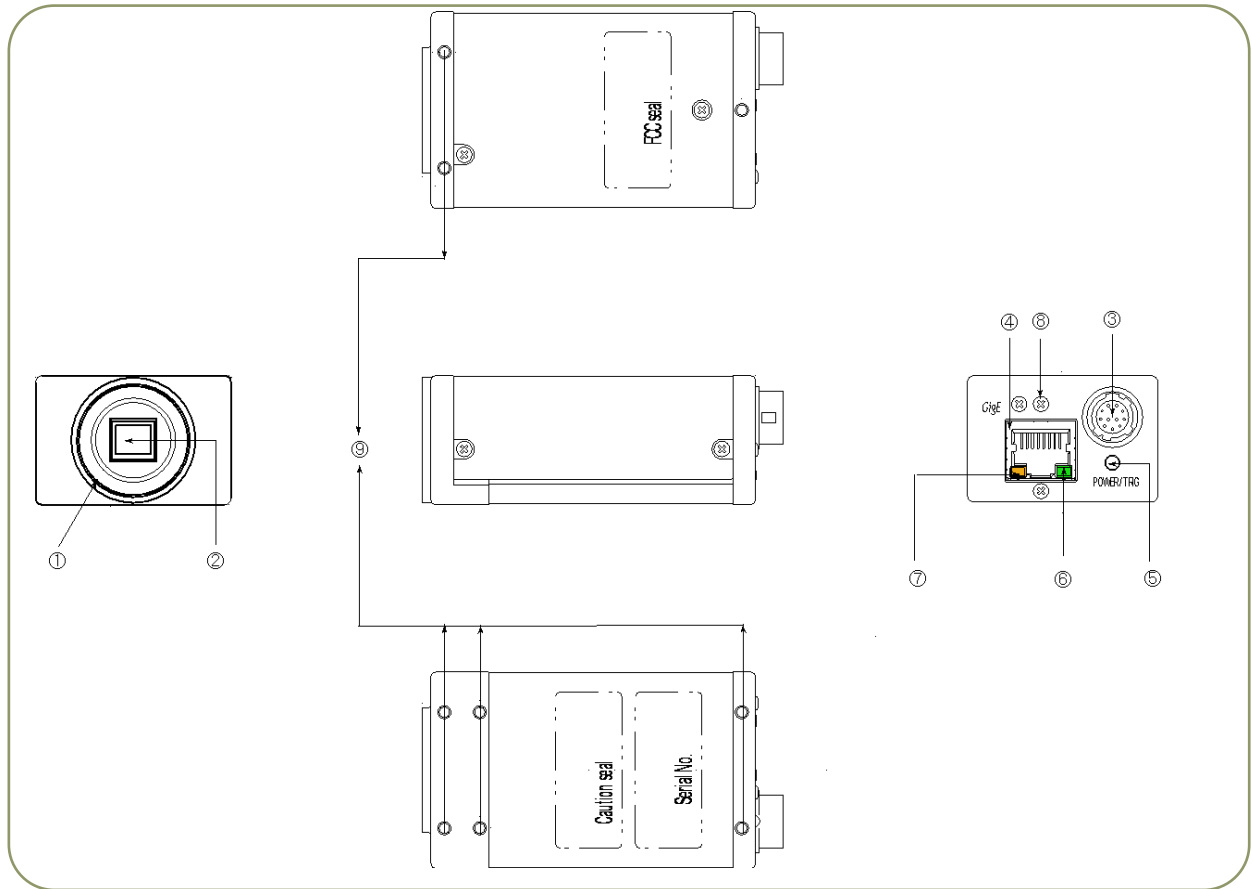

- |                               |   |
|-------------------------------|---|
| ① Lens mount                  | C-mount (Note *1)   |
| ② CCD sensor                  | 1/3 inch CCD sensor   |
| ③ 12-pin connector            | DC +12V power and GPIO interface  |
| ④ RJ-45                       | Gigabit Ethernet connector with threaded holes for thumbscrews  |
| ⑤ LED                         | Indication for power and trigger input  |
| ⑥ LED                         | GigE Network condition: LINK  |
| ⑦ LED                         | GigE Network condition: ACT   |
| ⑧ Holes for RJ-45 thumbscrews | When an RJ-45 connector with thumbscrews is used, remove the two screws located above and below the Ethernet connector (Note*2) |
| ⑨ Mounting holes              | M3 depth 3.5mm for tripod mount plate (Note * 3)  |

\*1) Note: Rear protrusion on C-mount lens must be less than 10.0mm.

\*2) Note: When a RJ-45 cable with thumbscrews is connected to the camera, please do not excessively tighten screws by using a screw driver. The RJ-45 receptacle on the camera might get damaged. For security, the strength to tighten screws should be less than 0.147 Newton meter (Nm). Tightening by hand is sufficient in order to achieve this.

\*3) Note: The depth of holes is 3.5mm. When the tripod adapter plate MP-40 or MP-41 is used, use the attached screws. If installing the camera directly, please do not use screws longer than 3.5mm.

Fig. 1. Locations

4.2. CM-030GE-RA and CB-030GE-RA

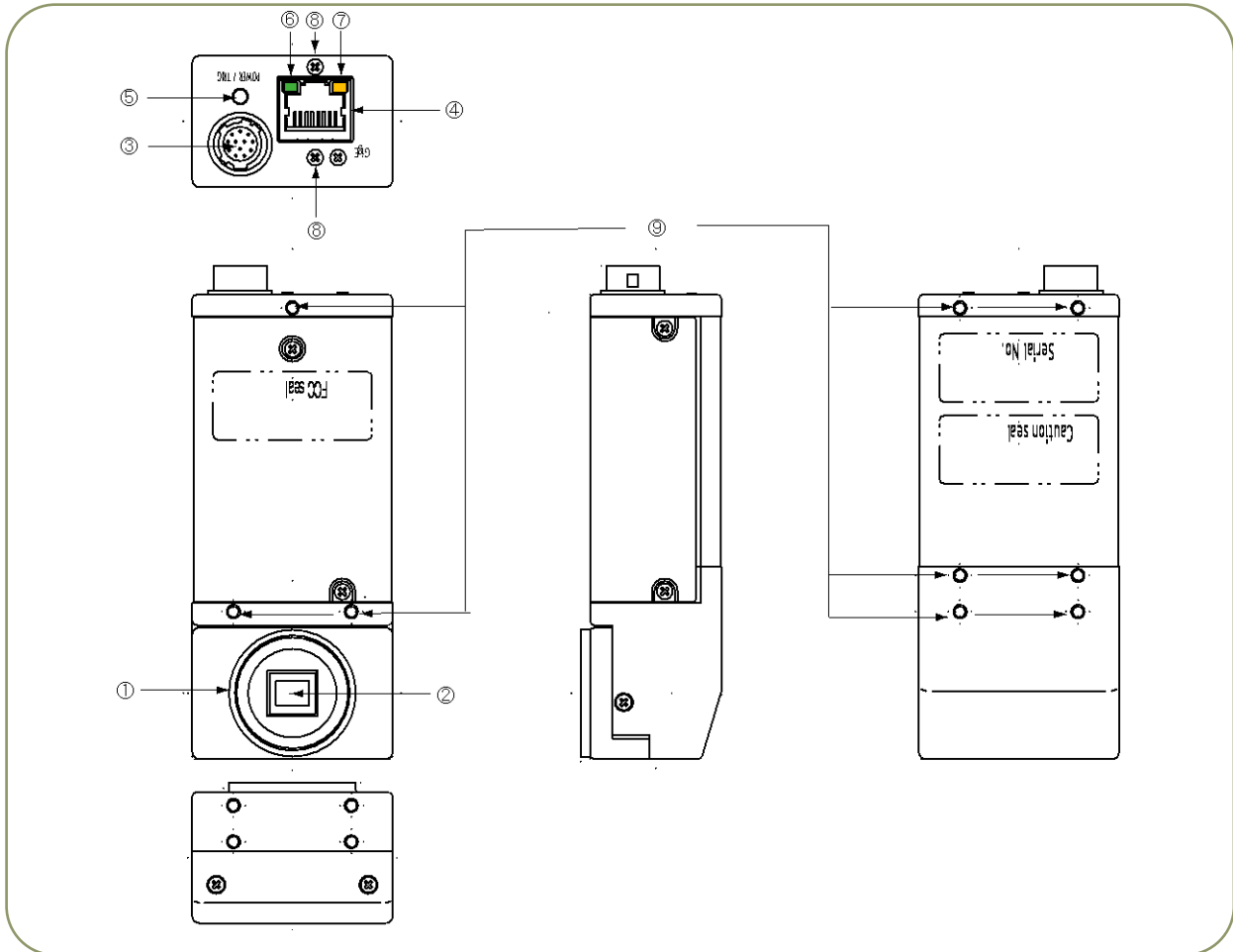

- |   |  |
|---|--|
| <ul style="list-style-type: none"> <li>① Lens mount</li> <li>② CCD sensor</li> <li>③ 12-pin connector</li> <li>④ RJ-45</li> <li>⑤ LED</li> <li>⑥ LED</li> <li>⑦ LED</li> <li>⑧ Holes for RJ-45 thumbscrews</li> <li>⑨ Mounting holes</li> </ul> | <ul style="list-style-type: none"> <li>C-mount (Note *1)</li> <li>1/3 inch CCD sensor</li> <li>DC +12V power and GPIO interface</li> <li>Gigabit Ethernet connector with threaded holes for thumbscrews</li> <li>Indication for power and trigger input</li> <li>GigE Network condition: LINK</li> <li>GigE Network condition: ACT</li> <li>When an RJ-45 connector with thumbscrews is used, remove the two screws located above and below the Ethernet connector (Note*2)</li> <li>M3 depth 3.5mm for tripod mount plate (Note*3)</li> </ul> |
|---|--|

\*1) Note: Rear protrusion on C-mount lens must be less than 10.0mm.

\*2) Note: When a RJ-45 cable with thumbscrews is connected to the camera, please do not excessively tighten screws by using a screw driver. The RJ-45 receptacle on the camera might get damaged. For security, the strength to tighten screws is less than 0.147 Newton meter (Nm). Tightening by hand is sufficient in order to achieve this.

\*3) Note: The depth of holes is 3.5mm. When the tripod adapter plate MP-40 or MP-41 is used, use the attached screws. If installing the camera directly, please do not use screws longer than 3.5mm.

Fig.2 Locations (CM-030GE-RA / CB-030GE-RA)

### 4.3. Rear panel indicator

The rear panel mounted LED provides the following information:

- Amber: Power connected - initiating
- Steady green : Camera is operating in Continuous mode
- ✱ Flashing green : The camera is receiving external trigger

Ethernet connector indicates,

- Steady green : 1000 Base-T has been connected
- ✱ Flashing green : 100 Base-TX has been connected (Note)
- ✱ Flashing amber : Network active in communication

Note: When 10BASE-T is connected, the green is also flashing.  
However, the video is not streamed through Ethernet.

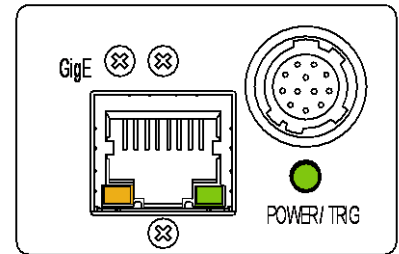

Fig.13. Rear Panel

## 5. Pin Assignment

### 5.1. 12-pin Multi-connector (DC-in/GPIO/Iris Video)

Type: HR10A-10R-12PB (Hirose) male.  
(Seen from rear of camera)

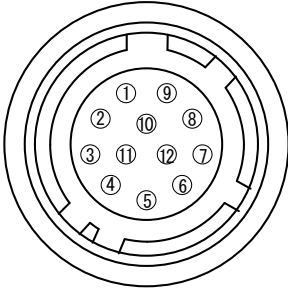
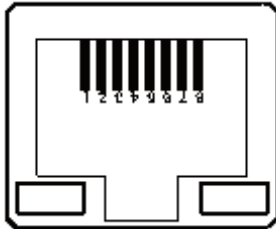

Fig. 4. 12-pin connector.

Pin no.	Signal	Remarks
1	GND	
2	+12 V DC input	
3	Opt IN 2 (-) / GND (*1)	GPIO IN / OUT
4	Opt IN 2 (+)/Iris Video out (*1)	
5	Opt IN 1 ( - )	
6	Opt IN 1 ( + )	
7	Opt Out 1 ( - )	
8	Opt Out 1 ( + )	
9	Opt Out 2 ( - )	
10	Opt Out 2 ( + )	
11	+ 12 V DC input	
12	GND	

\*1: Iris Video output function can be set by the internal DIP switch.

### 5.2. Digital Output Connector for Gigabit Ethernet



Type: RJ-45  
HFJ11-1G02E-L21RL or equivalent

The CM-030GE/CM-030GE-RA and CB-030GE/CB-030GE-RA cameras also accept industrial RJ-45 connectors with thumbscrews. This assures that the connector does not come undone in tough industrial environments.

Please contact the nearest JAI distributor for details on recommended industrial RJ-45 connectors.

Fig. 5. Gigabit Ethernet connector

The digital output signals follow the Gigabit Ethernet interface using RJ-45 conforming connector. The following is pin assignment for Gigabit Ethernet connector.

Pin No	In/Out	Name
1	In/Out	MX1+ (DA+)
2	In/Out	MX1- (DA-)
3	In/Out	MX2+ (DB+)
4	In/Out	MX3+ (DC+)
5	In/Out	MX3- (DC-)
6	In/Out	MX2- (DB-)
7	In/Out	MX4+ (DD+)
8	In/Out	MX4- (DD-)

## 6. Input and output interface

### 6.1. GPIO interface

All input and output signals pass through the GPIO (General Purpose Input and Output) module. The GPIO module consists of a Look-Up Table (LUT - Cross-Point Switch), 4 Pulse Generators and a 12-bit counter. In the LUT, the relationship between inputs, counters and outputs is governed by internal register set-up.

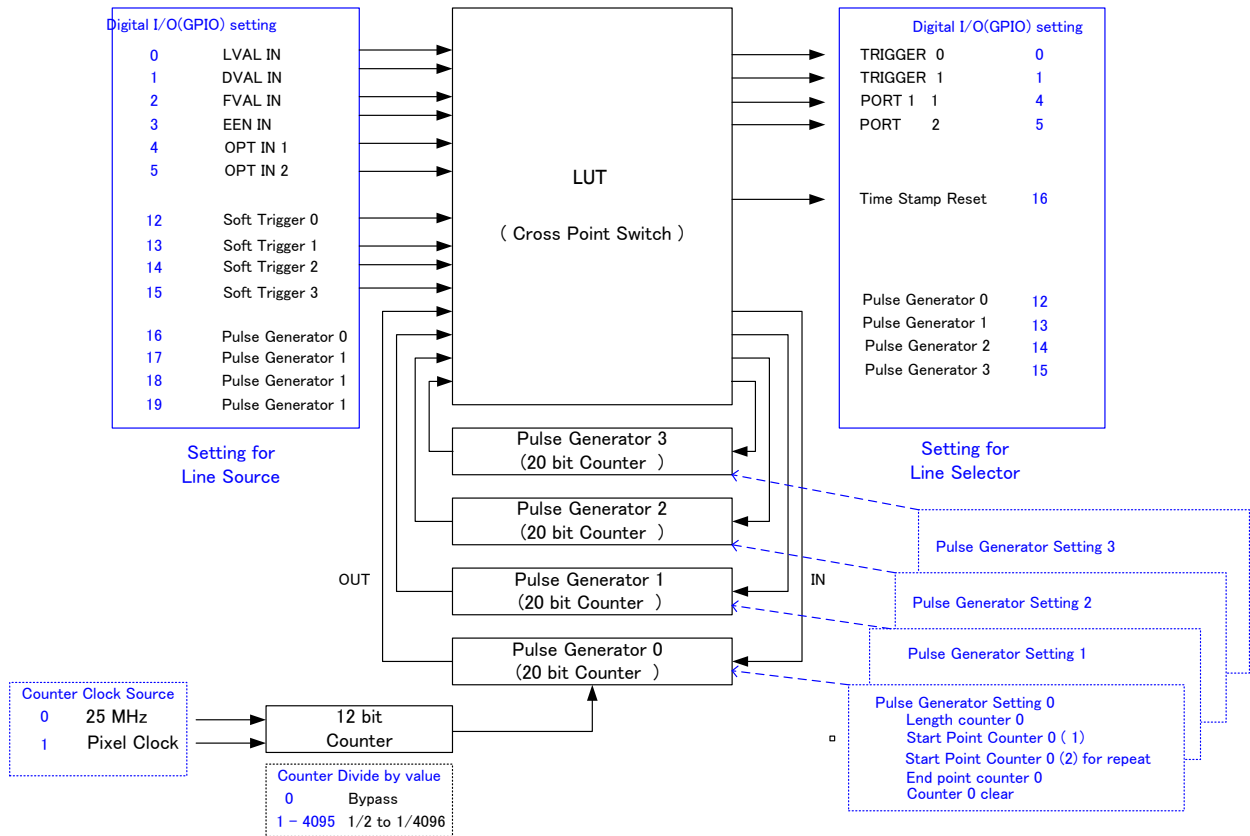

Fig.6 GPIO block

The input and output settings for the CM-030GE and CB-030GE series have been fixed as follows.

Line	Signal	Connector
Line 3	Optical Out 1	Hirose 12P pin # 7/8
Line 4	Optical Out 2	Hirose 12P pin # 9/10
Line 5	Optical In 1	Hirose 12P pin # 5/6
Line 6	Optical In 2	Hirose 12P pin # 3/4

#### 6.1.1 LUT (Look Up Table)

The LUT works as a cross-point switch, which allows connecting inputs and outputs freely. The signals LVAL\_IN, DVAL\_IN, FVAL\_IN and EEN\_IN all originate from the camera timing circuit.

Trigger 0 is connected to the camera's timing circuit and is used for initiating triggered exposure. Trigger 1 is used for Delayed Readout mode. The Time Stamp Reset signal is used to reset the camera's time stamp function, also making it possible to reset and synchronize the time stamp of multiple cameras.

### 6.1.2 12-bit Counter

A 25 MHz clock or the camera pixel clock (40 MHz) can be used as a source. The counter has a “Divide by N”, where N has the range 1 through 4096, allowing a wide range of clock frequencies to be programmed. Setting Value 0 is bypass, setting value 1 is 1/2 dividing and setting value 4095 is 1/4096 dividing.

h) Pulse Generators	
Clock Source	25 MHz
Clock Pre-scaler	25 MHz
Pulse Generator Clock (MHz)	Pixel Clock (65MHz)
Pulse Generator Selector	Pulse Generator 0

### 6.1.3. Pulse Generators (0 to 3)

Each pulse generator consists of a 20-bit counter. The behavior of these signals is defined by their pulse width, start point, end point and number of repetitions.

The pulse generator signals can be set in either triggered or periodic mode.

In triggered mode, the pulse is triggered by the rising edge/falling edge/high level or low level of the input signal.

In periodic mode, the trigger continuously generates a signal that is based on the configured pulse width, starting point and end point.

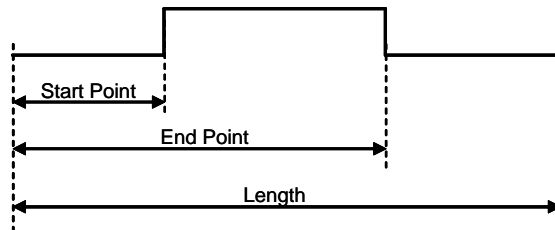

Fig.7 Generated pulse

#### Setting example:

The following example shows the FVAL input to pulse generator. The pulse generator creates the pulse using FVAL and the pulse is output through GPIO PORT 1. The pixel clock is 60MHz.

#### Pulse Generator Setting Example

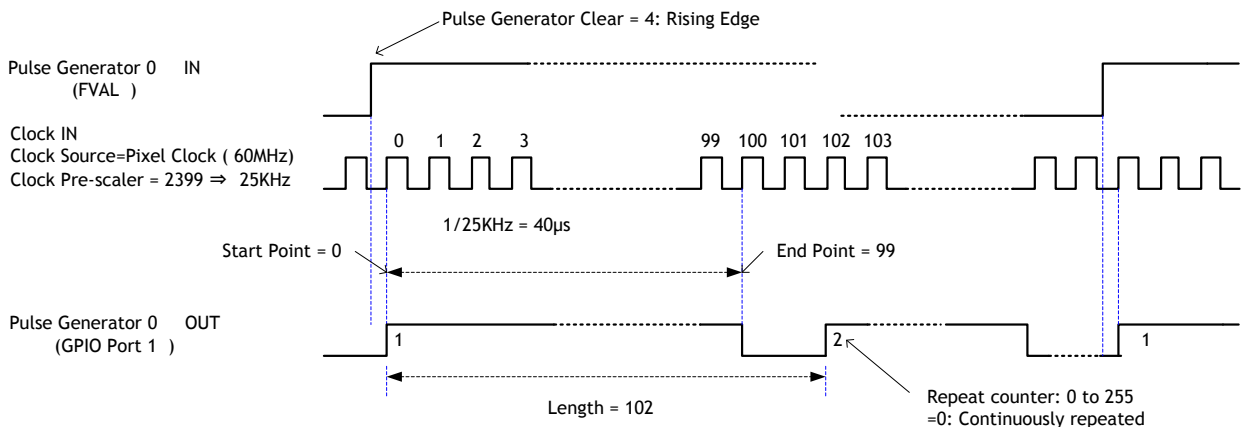

Fig 8. Pulse generator setting example

The created pulse rises up at the start point and falls down at the end point as shown above. Accordingly, the High duration is (End point - Start point) clocks x (1/ Pulse gen. frequency).

In the above example, the original oscillation uses pixel clock (60 MHz) and the pixel clock is divided by 2400. A pulse frequency of the generator is 25 KHz ( 60000000/2400). As the start point is 0 and the end point is 99, the pulse having  $100 \times 1/25000 = 4\text{ms}$  width is created.



If the HIGH duration needs to be delayed against incoming trigger, the start point should be set at “N“. The delay value is  $N \times (1 / 25000)$ .

In the above example, N is “0” which is no delay.

The length, in this case, is 102 clocks.

These settings can be achieved by JAI Control tool which is the part of JAI SDK.

h) Pulse Generators	
Clock Source	25 MHz
Clock Pre-scaler	1
Pulse Generator Clock (MHz)	25.00000
Pulse Generator Selector	Pulse Generator 0
Pulse Generator Length	1
Pulse Generator Length (ms)	0.00004
Pulse Generator Frequency (Hz)	25000000.00000
Pulse Generator Start Point	0
Pulse Generator Start Point (ms)	0.00000
Pulse Generator End Point	1
Pulse Generator End Point (ms)	0.00004
Pulse Generator pulse-width (ms)	4E-05
Pulse Generator Repeat Count	0
Pulse Generator Clear Activation	Free Run
Pulse Generator Clear Source	Off
Pulse Generator Clear Inverter	False

## 6.2. Opto-isolated Inputs/Outputs

The control interface of the C3 GigE Vision camera series has opto-isolated inputs and outputs, providing galvanic separation between the camera's inputs/outputs and peripheral equipment. In addition to galvanic separation, the opto-isolated inputs and outputs can cope with a wide range of voltages; the voltage range for inputs is +3.3V to +24V DC whereas outputs will handle +5V to +24V DC.

The below figure shows the functional principle (opto-coupler) of the opto-isolated inputs/outputs.

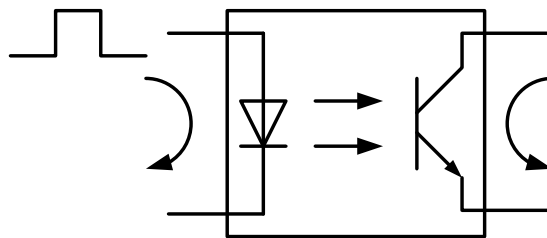

Fig.9. Opto-coupler

6.2.1 Recommended External Input circuit diagram for customer

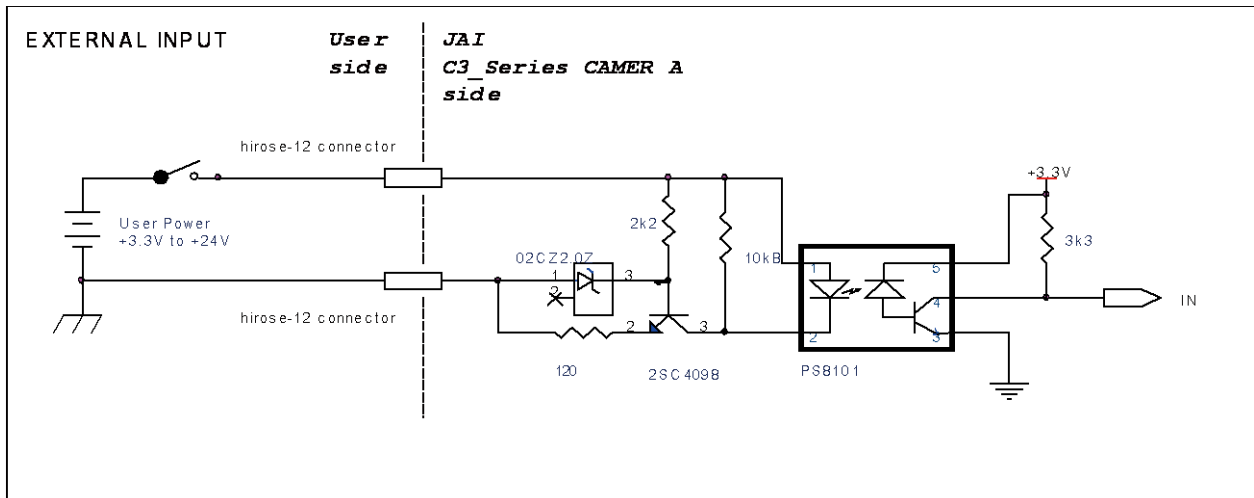

Fig.10 External Input Circuit, OPT IN 1 and 2

6.2.2 Recommended External Output circuit diagram for customer

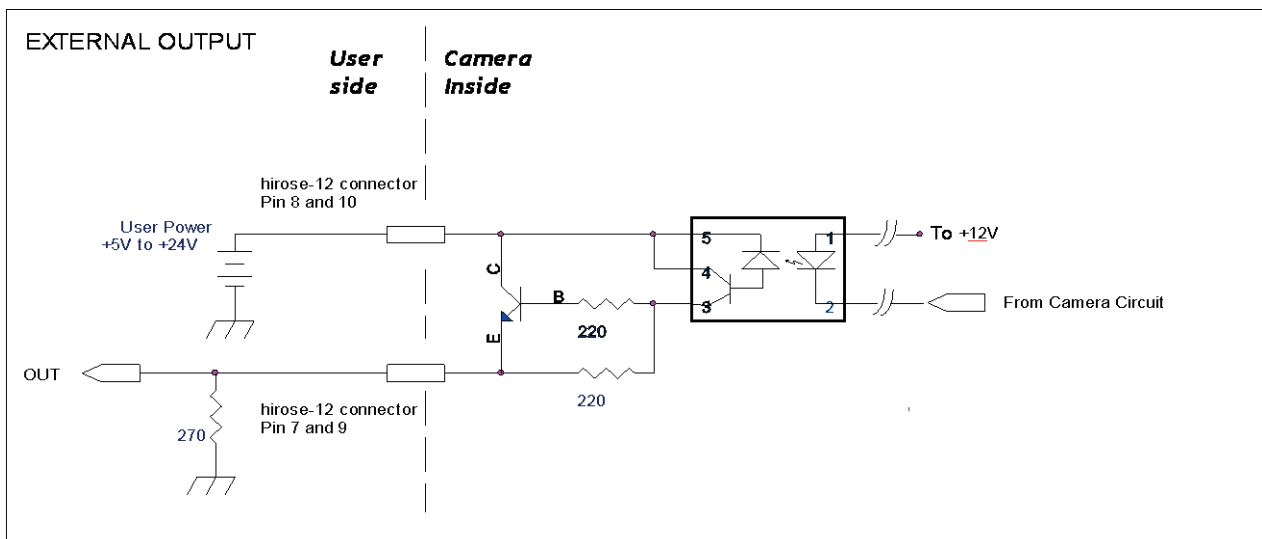
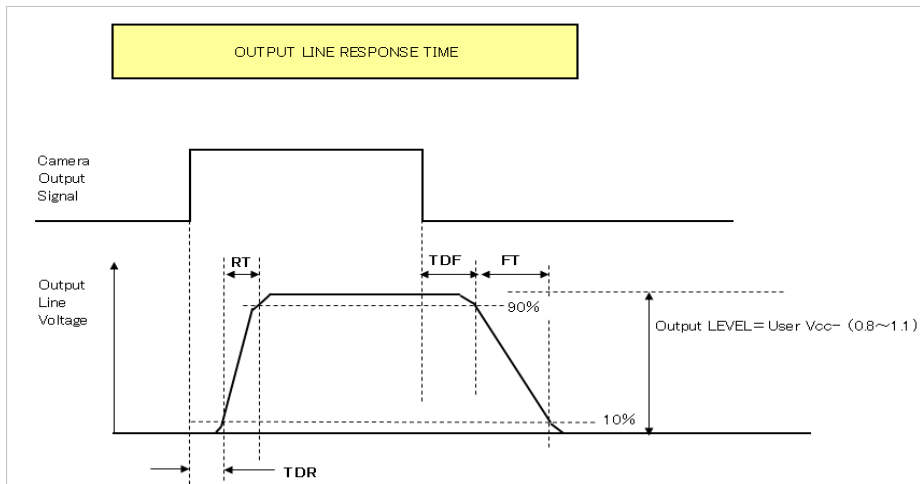

Fig.11. External Output Circuit, OPT OUT 1 and 2

### 6.2.3 Optical Interface Specifications

The relation of the Input signal and the output signal through optical interface is as follows.



Conditions for Input	
Input Line Voltage Range	+3.3v ~ +24V
Input Current	6mA ~ 30mA
Minimum Input Pulse Width to Turn ON	0.5us
Output Specifications	
Output Load(Maximum Current)	100mA
Minimum Output Pulse Width	20us
Time Delay Rise TDR	0.5us ~ 0.7us
Rise Time RT	1.2us ~ 3.0us
Time Delay Fall TDF	1.5us ~ 3.0us
Fall Time FT	4.0us ~ 7.0us

Fig.12. Optical Interface Performance

### 4.1 Inputs and outputs table

		Output Port								
		Trigger 0	Trigger 1	OPT OUT1	OPT OUT2	Time Stamp Reset	Pulse Gen. 0	Pulse Gen. 1	Pulse Gen. 2	Pulse Gen. 3
Input Port	LVAL IN	x	x	x	x	x	o	o	o	o
	DVAL IN	x	x	x	x	x	o	o	o	o
	FVAL IN	x	x	x	x	x	o	o	o	o
	EEN IN	x	x	o	o	x	o	o	o	o
	OPT IN 1	o	o	o	o	o	o	o	o	o
	OPT IN 2	o	o	o	o	o	o	o	o	o
	Soft Trigger 0	o	o	o	o	o	o	o	o	o
	Soft Trigger 1	o	o	o	o	o	o	o	o	o
	Soft Trigger 2	o	o	o	o	o	o	o	o	o
	Soft Trigger 3	o	o	o	o	o	o	o	o	o
	Pulse Gen. 0	o	o	o	o	o	x	o	o	o
	Pulse Gen. 1	o	o	o	o	o	o	x	o	o
	Pulse Gen. 2	o	o	o	o	o	o	o	x	o
	Pulse Gen. 3	o	o	o	o	o	o	o	o	x

LEGEND: 0 = valid combination / x = Not valid (do not use this combination)

## 6.4. Configuring the GPIO module

### 6.4.1 Input/Output Signal Selector

#### Line selector

This sets the input and output to the external equipment. Line 3 through line 6 are already allocated as below.

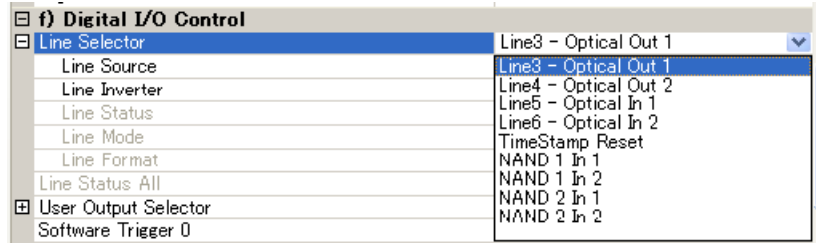

#### Line source

This sets which signal can be fed through selected output, external or internal.

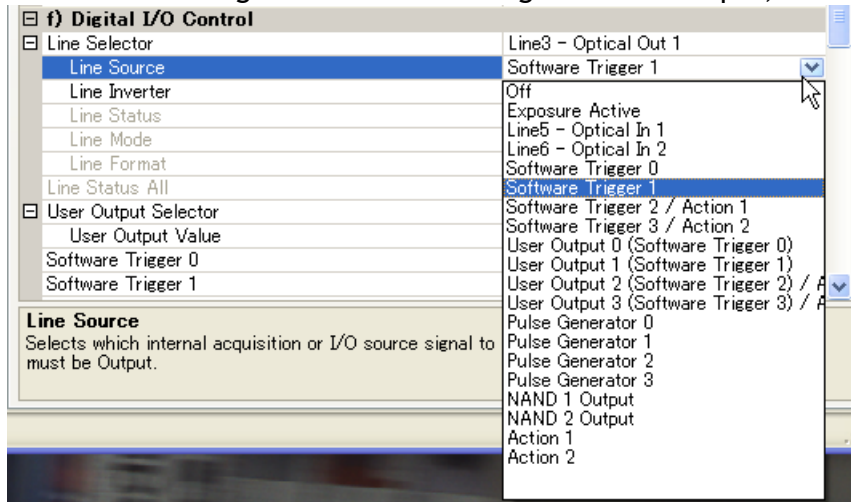

## 6.5. Examples of the pulse generator configuration

### 6.5.1 Setting screen of the pulse generator

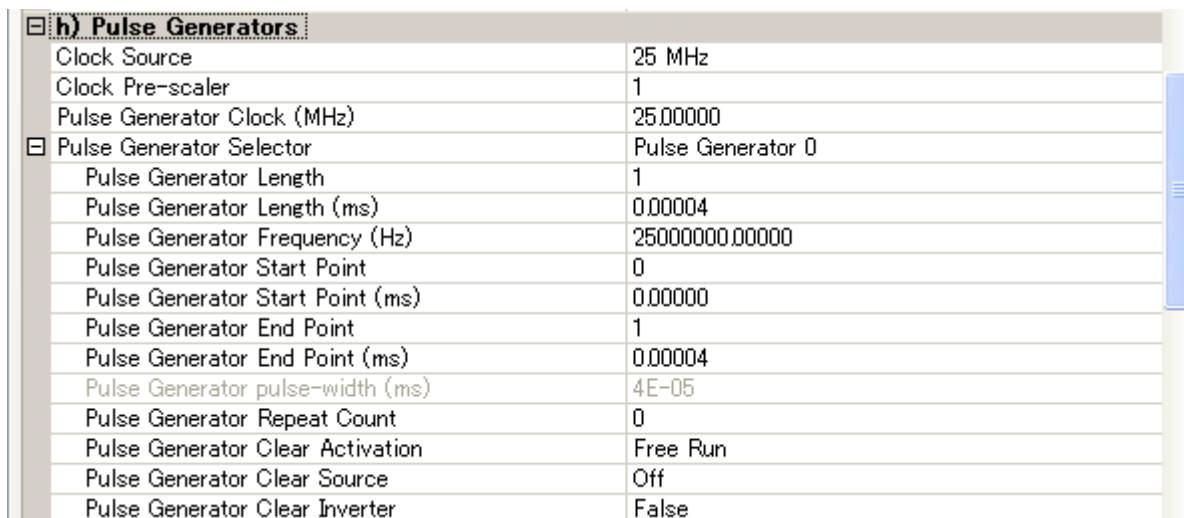

6.5.2 GPIO in combination with Pulse Width trigger mode

Example: 10µs unit pulse width exposure control (PWC).

Pixel clock is 40MHz. 400 clocks (500-100) equals 10µs.

Feature			Value
c)Acquisition and Trigger controls	Trigger selector	Trigger Mode	ON
JAI Acquisition and Trigger Control	JAI Exposure Mode		Pulse width control
Pulse Generators	Pulse Generator selector	Pulse Generator 0 Selector	Line 5 =OPT IN 1
		Clock Choice	1 = Pixel Clock (40MHz)
		Counter Dividing Value	0 = Pass through
		Length Counter 0	1000 Clocks
		Start point Counter 0	100 Clocks
		Repeat Count 0	1
		End point Counter 0	500 Clocks
		Counter Clear 0	Rising Edge
		Trigger source	pulse generator 0

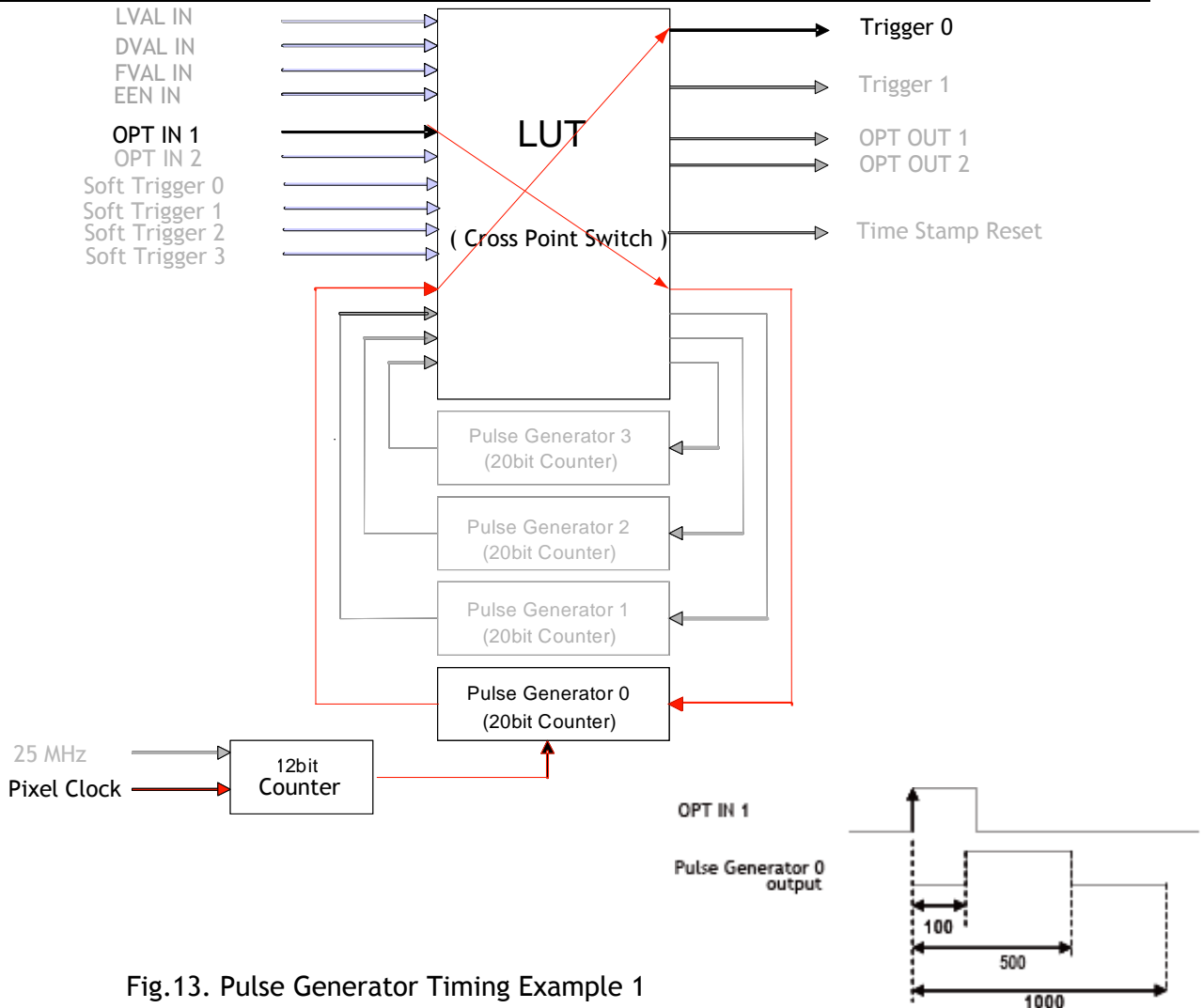

Fig.13. Pulse Generator Timing Example 1

### 6.5.3 Internal Trigger Generator

Create a trigger signal and trigger the camera

Feature			Value
c)Acquisition and Trigger controls	Trigger selector	Trigger Mode	ON
Pulse Generators	Pulse Generator selector	Pulse Generator 0 Selector	
		Clock Choice	1 = Pixel Clock (40MHz)
		Counter Dividing Value	864(line rate)
		Length Counter 0	1000 Clocks
		Start point Counter 0	100 Clocks
		Repeat Count 0	0
		End point Counter 0	500 Clocks
		Clear activation	Off
		Trigger source	pulse generator 0

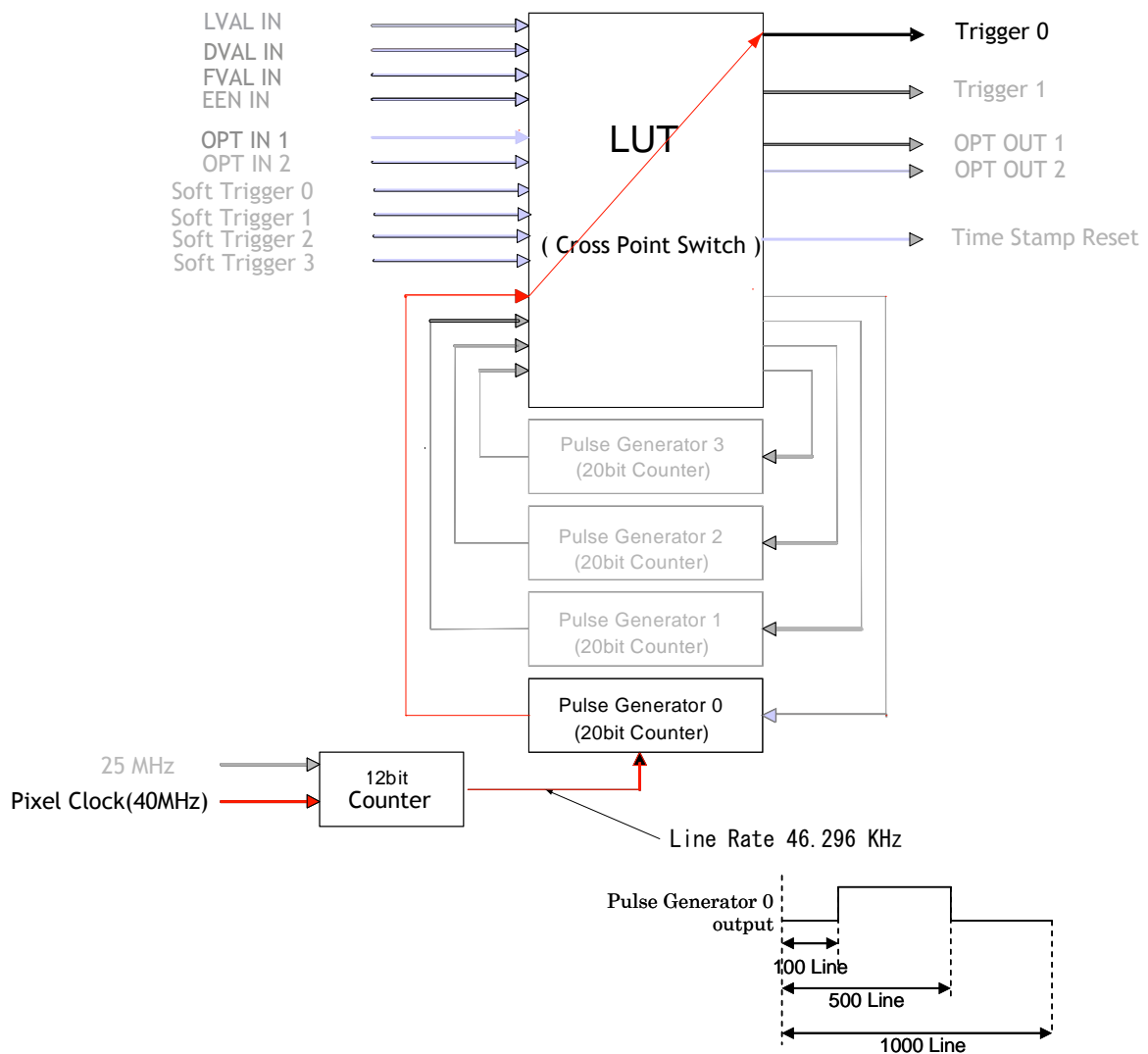

Fig.14. Pulse Generator 0 timing Example 2

## 7. Image output signal

### 7.1. Output image

The CCD sensor layout with respect to pixels and lines used in the timing and video full frame read out is shown below.

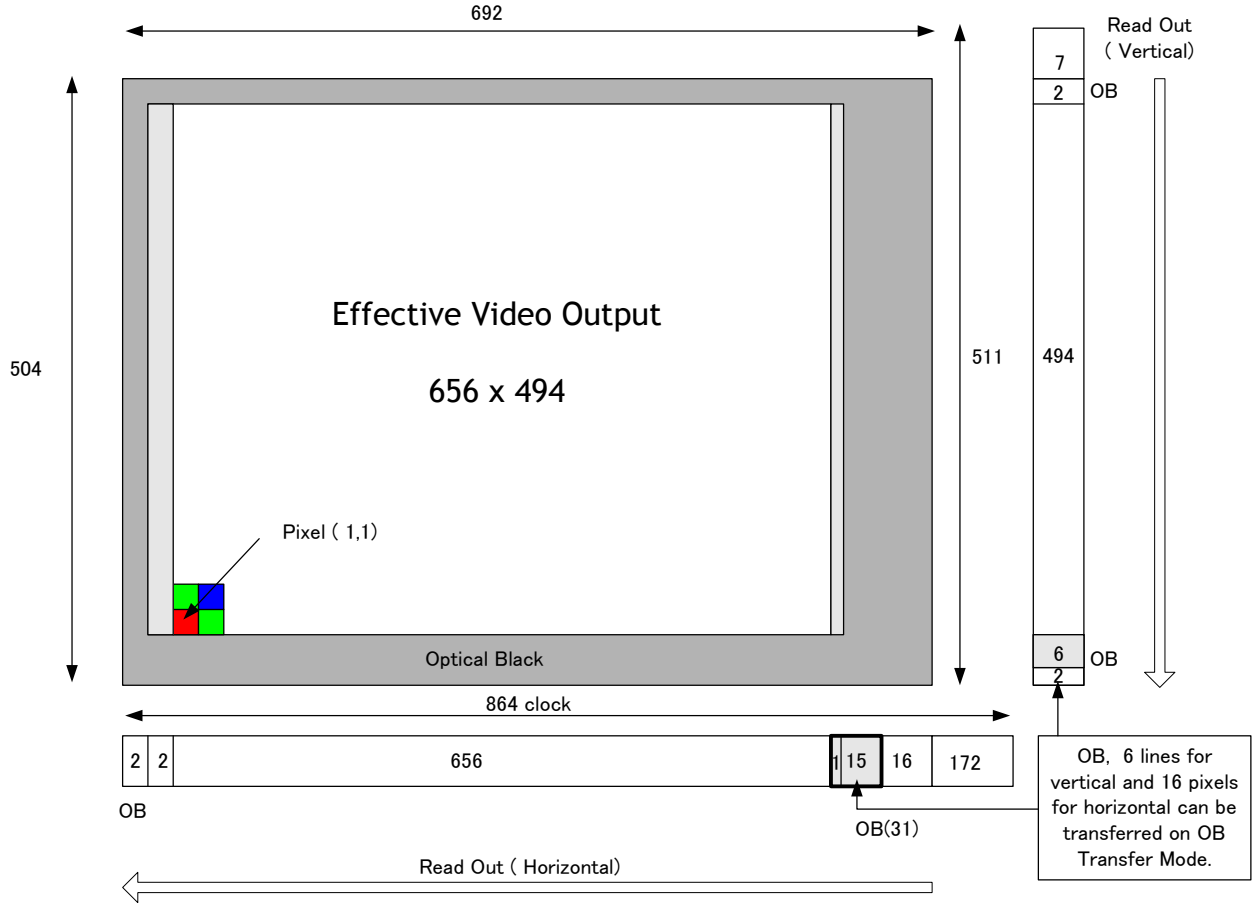

Fig. 15. CCD sensor layout

**Important Note:** By using the Optical Black (OB) transfer mode, the user can select whether to include optical black pixels in the image stream.

### 7.2. Vertical Binning (CM-030GE/CM-030GE-RA only)

The binning functions can be used to achieve higher frame rate or higher sensitivity. The drawback is lower resolution.

Vertical binning is done by adding the charge from pixels in adjacent lines in the horizontal CCD register.

Fig. 13 shows the binning principle. Resolution and frame rate for all combinations are shown in the below table.

Fig.13. CM-030GE/CM-030GE-RA binning

The CM-030GE/CM-030GE-RA has ON or OFF function for Vertical Binning:

Setting	Value for Register address 0xA084	Resolution	Frame rate
Off (no binning)	0x01	656(h) x 494(v) pixels	90.5 fps
2:1 binning	0x02	656(h) x 247(v) pixels	166.2 fps

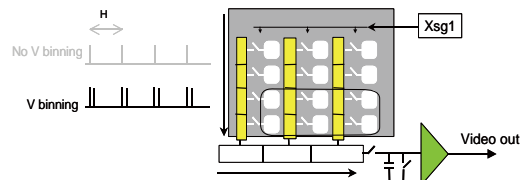

### 7.3. Digital Video Output (Bit Allocation)

Although the CM-030GE/CM-030GE-RA and CB-030GE/CB-030GE-RA are digital cameras, the image is generated by an analog component, the CCD sensor.

The table and diagram below show the relationship between the analog CCD output level and the digital output.

CCD out	Analog Signal *	Digital Out(10-bit)
Black	Setup 3.6%, 25mV	32LSB
200mV	700mV	890LSB
230mV	800mV	1023LSB

The standard setting for 10-bit video level is 890 LSB. 200 mV CCD output level equals 100% video output.

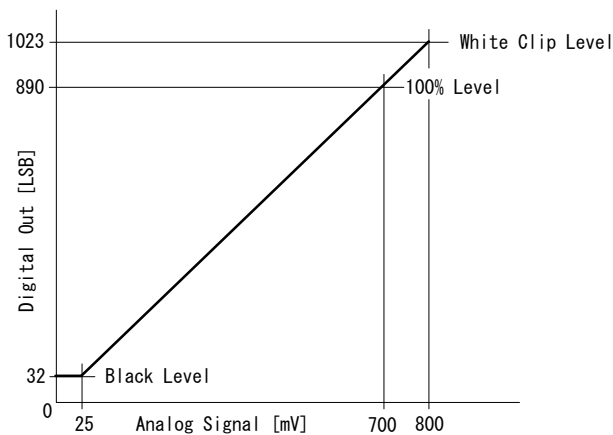

Fig. 17. Digital Output

#### 7.3.1 Bit Allocation (Pixel Format / Pixel Type) - CM-030GE/CM-030GE-RA

In the GigE Vision Interface, GVSP (GigE Vision Streaming Protocol) is used for an application layer protocol relying on the UDP transport layer protocol. It allows an application to receive image data, image information and other information from a device.

In the monochrome camera, CM-030GE/CM-030GE-RA, the following pixel types supported by GVSP are available.

With regard to the details of GVSP, please refer to GigE Vision Specification available from AIA ([www.machinevisiononline.org](http://www.machinevisiononline.org)).

##### 7.3.1.1 GVSP\_PIX\_MONO8 (8bit)

1Byte								2Byte								3Byte							
Y0								Y1								Y2							
0	1	2	3	4	5	6	7	0	1	2	3	4	5	6	7	0	1	2	3	4	5	6	7

##### 7.3.1.2 GVSP\_PIX\_MONO10 (10bit)

1Byte								2Byte								3Byte								4Byte							
Y0								Y0								Y1								Y1							
0	1	2	3	4	5	6	7	8	9	X	X	X	X	X	X	0	1	2	3	4	5	6	7	8	9	X	X	X	X	X	X



## CM-030GE/CM-030GE-RA / CB-030GE/CB-030GE-RA

### 7.3.1.3 GVSP\_PIX\_MONO10\_PACKED (10 bit)

Y0										Y1										Y2										Y3																	
2	3	4	5	6	7	8	9	0	1	X	X	0	1	X	X	2	3	4	5	6	7	8	9	2	3	4	5	6	7	8	9	0	1	X	X	0	1	X	X	2	3	4	5	6	7	8	9

Address	Internal Name	Access	Size	Value
0xA410	Pixel Format type	R/W	4	0x01080001:Mono8 0x01100003:Mono10 0x010C0004:Mono10 Packed

### 7.3.2 Bit Allocation (Pixel Format / Pixel Type) - CB-030GE/CB-030GE-RA

In the GigE Vision Interface, GVSP (GigE Vision Streaming Protocol) is used for an application layer protocol relying on the UDP transport layer protocol.

With regard to the details of the GVSP, please refer GigE Vision Specification available from AIA ([www.machinevisiononline.org](http://www.machinevisiononline.org)).

#### 7.3.2.1 GVSP\_PIX\_BAYRG8 “BayreRG8 “

Odd Line

1 Byte	2 Byte	3 Byte
<b>R0</b>	<b>G1</b>	<b>R2</b>
0 1 2 3 4 5 6 7	0 1 2 3 4 5 6 7	0 1 2 3 4 5 6 7

Even Line

<b>G0</b>	<b>B1</b>	<b>G2</b>
0 1 2 3 4 5 6 7	0 1 2 3 4 5 6 7	0 1 2 3 4 5 6 7

#### 7.3.2.2 GVSP\_PIX\_BAYRG10 “Bayer RG10”

Odd Line

1 Byte	2 Byte	3 Byte	4 Byte
<b>R0</b>	<b>R0</b>	<b>G1</b>	<b>G1</b>
0 1 2 3 4 5 6 7	8 9 X X X X X X X	0 1 2 3 4 5 6 7	8 9 X X X X X X X

Even Line

<b>G0</b>	<b>G0</b>	<b>B1</b>	<b>B1</b>
0 1 2 3 4 5 6 7	8 9 X X X X X X X	0 1 2 3 4 5 6 7	8 9 X X X X X X X

#### 7.3.2.3 GVSP\_PIX\_BAYGB8 “BayerGB8”

Odd Line

<b>G0</b>	<b>B1</b>	<b>G2</b>
0 1 2 3 4 5 6 7	0 1 2 3 4 5 6 7	0 1 2 3 4 5 6 7

Even Line

<b>R0</b>	<b>G1</b>	<b>R2</b>
0 1 2 3 4 5 6 7	0 1 2 3 4 5 6 7	0 1 2 3 4 5 6 7

#### 7.3.2.4 GVSP\_PIX\_BAYGB10 “BayerGB10”

Odd Line

1 Byte	2 Byte	3 Byte	4 Byte
<b>G0</b>	<b>G0</b>	<b>B1</b>	<b>B1</b>
0 1 2 3 4 5 6 7	8 9 X X X X X X X	0 1 2 3 4 5 6 7	8 9 X X X X X X X

Even Line

<b>R0</b>	<b>R0</b>	<b>G1</b>	<b>G1</b>
0 1 2 3 4 5 6 7	8 9 X X X X X X X	0 1 2 3 4 5 6 7	8 9 X X X X X X X

Address	Internal Name	Access	Size	Value
0xA410	Pixel Format type	R/W	4	0x01080009: BAYRG8 0x0108000A: BAYGB8 0x0110000D: BAYRG10 0x0110000E: BAYGB10

Note: CB-030GE/CB-030GE-RA has the same Bayer sequence for Full and any of partial scanning as RG. Therefore, comparing full scanning and partial scanning, the center might be shifted.

As the Pixel Format type, CB-030GE/CB-030GE-RA supports BAYER GB 8 and BAYER GB 10. When these types are selected, the output starts from 2nd line for all scanning.

### 7.4. CB-030GE/CB-030GE-RA. Bayer filter

CB-030GE/CB-030GE-RA is a color camera based on a CCD sensor with a Bayer RGB color mosaic. The color image reconstruction is done in the host PC. The Color sequence in the video signal is the same for all scanning formats.

The line readout follows LVAL.

The first valid pixel is the same timing as DVAL.

The Bayer color sequence starts with:

RGR for odd numbers.

GBG for even line numbers.

Figure 14 shows the timing sequence for the Bayer mosaic read-out for the available partial scan modes.

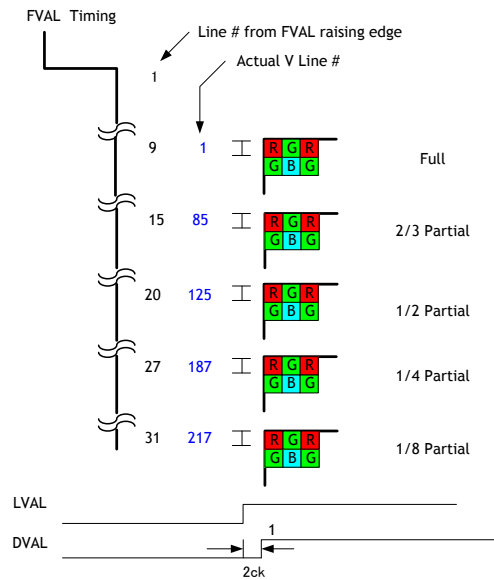

Fig.18. Bayer layout for each scanning

7.5. Image timing

7.5.1 Horizontal timing

The LVAL period is shown for normal continuous mode.

FULL FRAME READ OUT / PATIAL READ OUT

1LVAL 864ck = 21.6us      1ck= 25ns

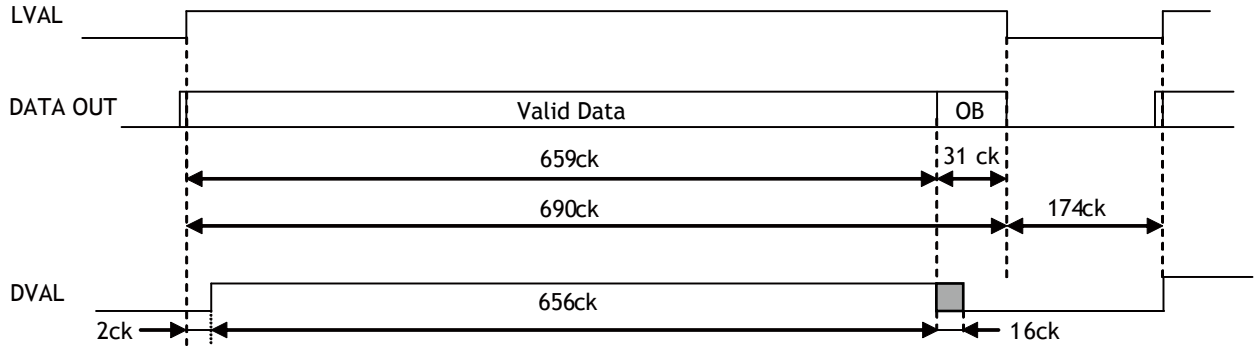

Fig. 19. Horizontal timing

7.5.2 Vertical timing

The FVAL period for normal continuous mode full scan is shown.

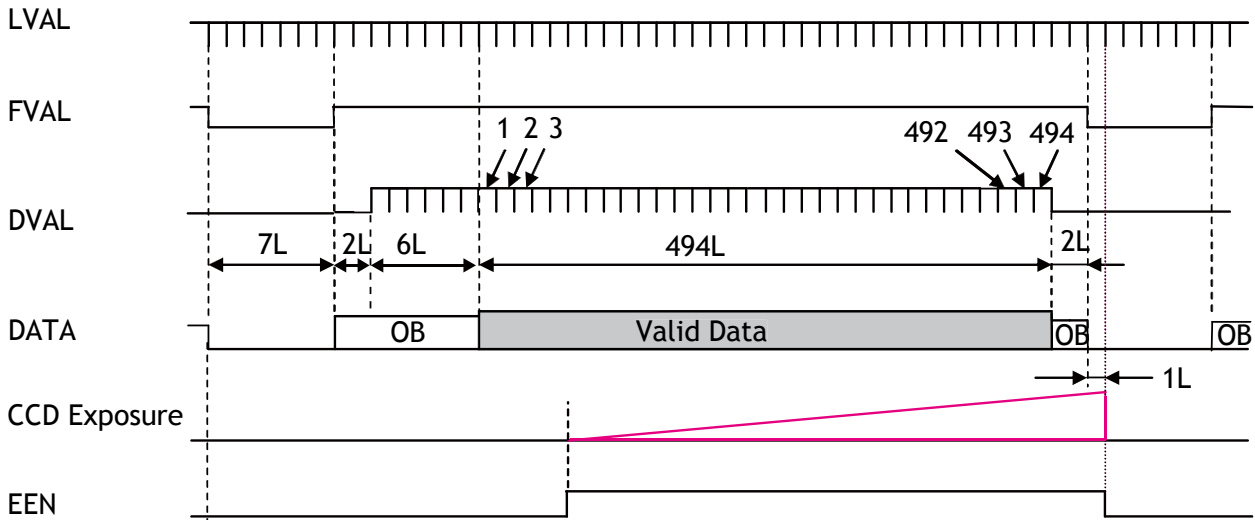

Fig. 20. Vertical timing for full scan

### 7.5.3 Partial Scanning

The FVAL period is shown for 1/2 partial scan in normal continuous mode.

#### 7.5.3.1 Vertical Timing

The below diagram and table provide vertical timing information for the fixed partial scan settings 1/2, 1/4, 1/3 and 2/3

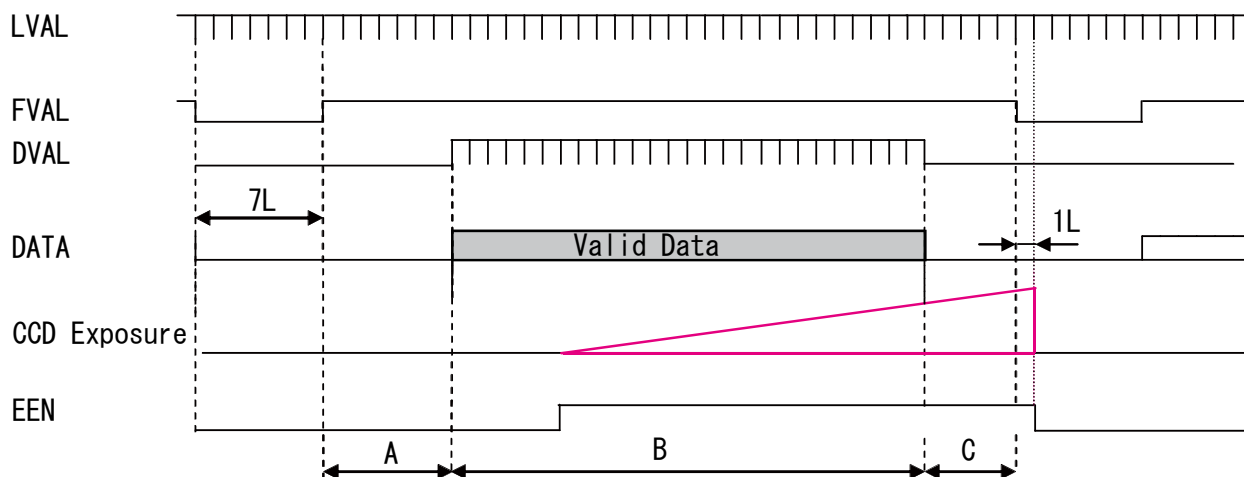

Values for vertical timing in partial scan continuous mode.

AREA	FVAL Low (L)	A (L)	B (L)		C (L)	Total line	frame rate
			Start line	End line			
1/2	7	19	246		18L	290L	159.64
			125	370			
1/4	7	26	122		26L	181L	255.75
			187	308			
1/8	7	30	62		29L	128L	361.68
			217	278			
2/3	7	14	326		13L	360L	128.6
			85	410			

Fig. 21. Vertical timing for partial scanning

7.5.3.2 Horizontal Timing

The horizontal timing is the same the full scanning.

FULL FRAME READ OUT / PATIAL READ OUT

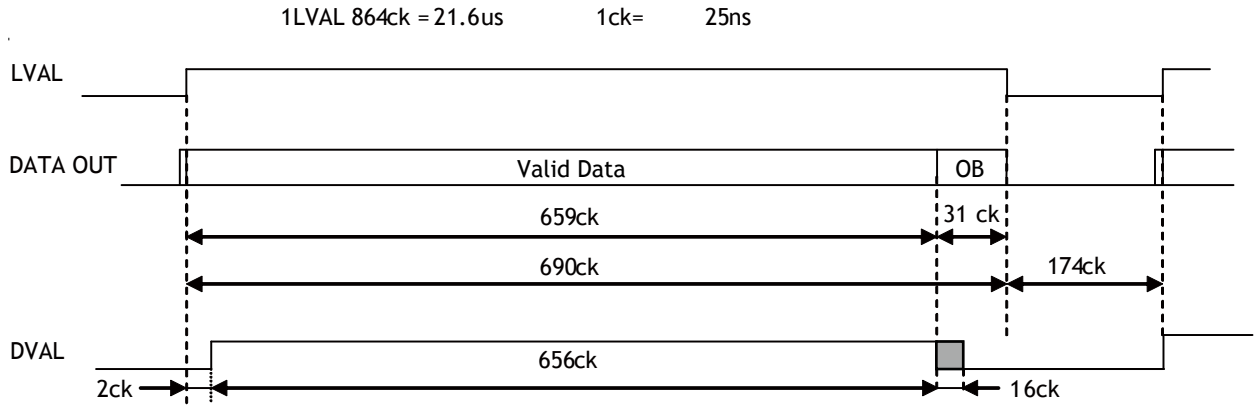

Fig.22. Horizontal Timing for Partial Scanning

7.5.4 Vertical binning

Vertical binning combines charge from two adjacent lines, reducing the vertical resolution to half and at the same time increasing frame rate and sensitivity. By activating this function, the frame rate is increased to 166.2 fps.

This function is available only for CM-030GE/CM-030GE-RA.

**Important Note**

Vertical Binning cannot be used together with the Partial Scanning.

7.5.4.1 Horizontal Timing

V binning

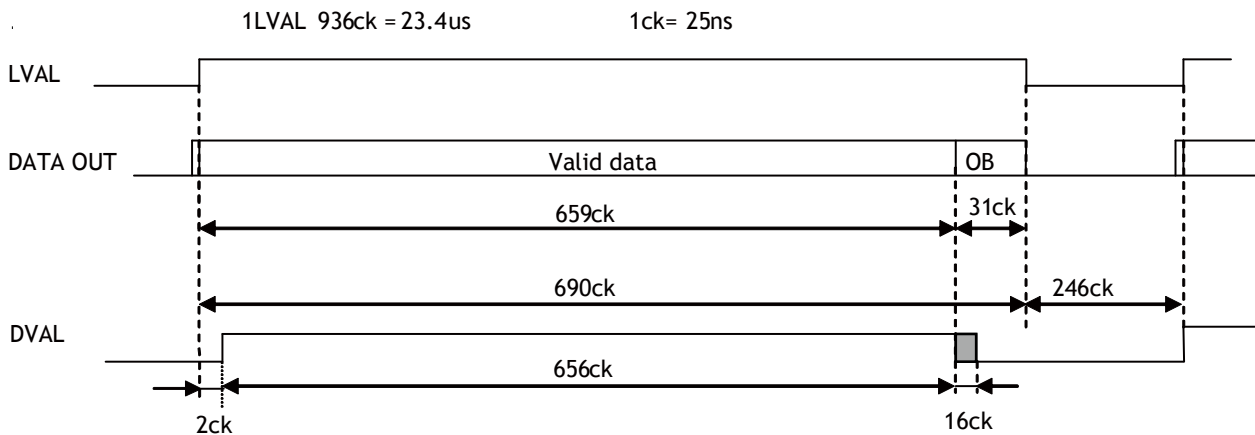

Fig.23. Horizontal Timing for Vertical Binning

### 7.5.4.2 Vertical timing

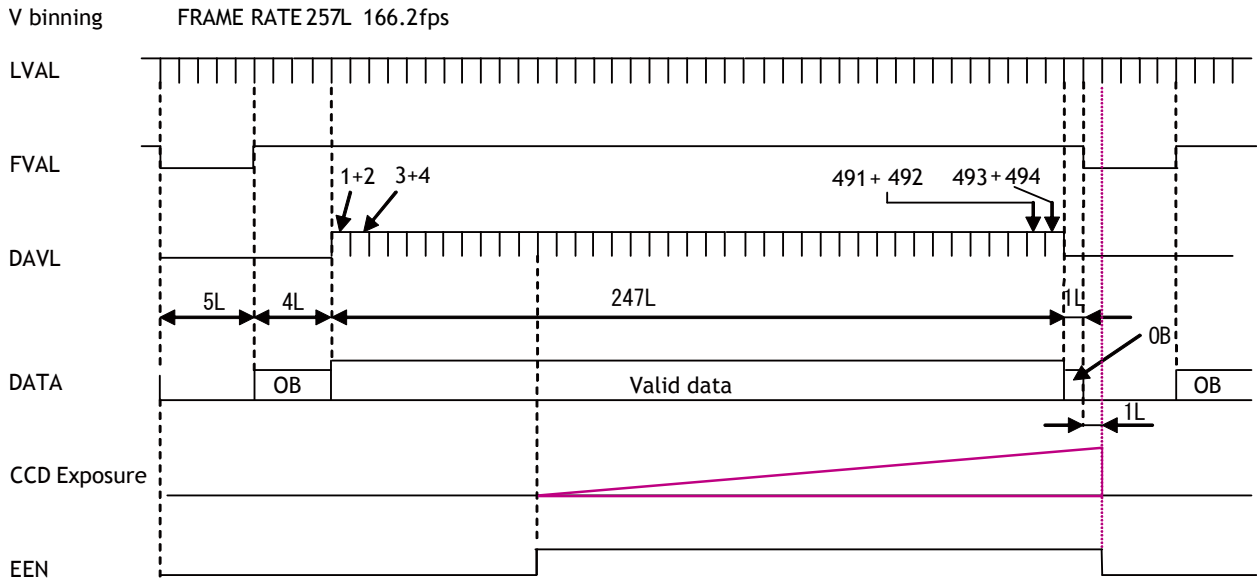

Fig.24. Vertical Timing for Vertical Binning

### 7.5.5 Auto Iris Lens video output (12-pin Hirose connector)

This analogue signal is not routed through the GPIO. This signal is available at pin 4 of 12-pin Hirose connector. It can be used for lens iris control in Continuous and RCT modes only. The signal is taken from the CCD sensor and is output after the gain circuit. The video output is without sync. The signal is 0.7 Vpp from <math>400\Omega</math> AC coupled.

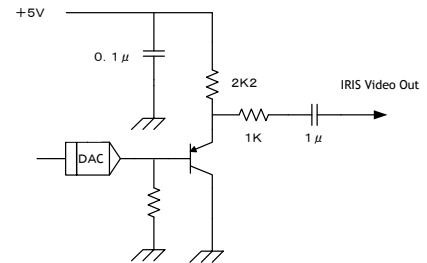
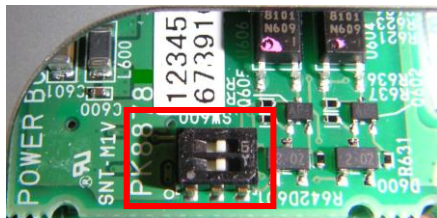

Fig.25. Iris circuit

To use this signal, the internal DIP switch must be set as follows.



The auto-iris lens video output is enabled by setting switch SW600 to ON (Two Switches to the left). The internal DIP switch is set to OFF (Two Switches to the right) as factory default.

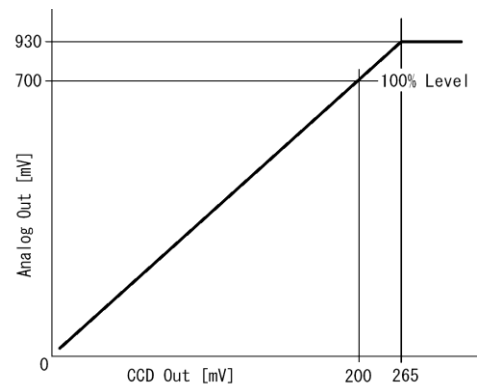

Fig. 26. Iris video output.

## **8. Network configuration**

- ➔ For details of the network settings, please refer to the “Getting Started Guide” supplied with the JAI SDK.

### **8.1. GigE Vision Standard Interface**

The CM-030GE/CM-030GE-RA and CB-030GE/CB-030GE-RA are designed in accordance with the GigE Vision standard. It transmits digital images over Cat5e or Cat6 Ethernet cables. All camera functions are also controlled via the GigE Vision interface.

The camera can operate in continuous mode, providing an endless stream of images. For capturing individual images, related to a specific event, the camera can also be triggered. For precise triggering, it is recommended to use a hardware trigger applied to the Hirose 12-pin connector. It is also possible to initiate a software trigger through the GigE Vision interface. However, when using software trigger, certain latency inherent to the GigE interface must be anticipated. This latency, that manifests itself as jitter, greatly depends on the general conditions and traffic on the GigE connection. The frame rate described in this manual is for the ideal case and may deteriorate depending on conditions.

When using multiple cameras (going through a switch and/or a single path) or when operating in a system with limited transmission bandwidth the Delayed Readout Mode and Inter-Packet Delay functions can be useful.

### **8.2. Equipment to configure the network system**

#### **8.2.1 PC**

The PC used should have the following performance or better

- 1) Recommended CPU : Core2 Duo 2.4GHz or better,  
Better than Core2 Extreme
- 2) Recommended memory : 2Gbyte or more
- 3) Video card : Better than PCI Express Bus Ver.1.0 x16  
VRAM should be better than 256MByte, DDR2
- 4) Other : The resident software should not be used

#### **8.2.2 Cables**

GigEVision configures the system by using 1000BASE-T. (100BASE-T can be used with some restriction. Refer to chapter 8.3.6). In the market, CAT5e (125MHz), CAT6 (250MHz) and CAT7 (600MHz) cables are available for 1000BASE-T. There are crossover cables and straight through cables available. Currently, as most equipment complies with Auto MDI/MDI-X, please use straight through cables. (Among crossover cables, a half crossover type exists, which the Ethernet will recognize as 100BASE-T).

#### **8.2.3 Network card (NIC)**

The network card should comply with 1000BASE-T and also have the capability of JUMBO FRAMES. When the jumbo frame size is set at a larger number, the load on the CPU will be decreased. Additionally, as the overhead of the packet is decreased, the transmission will have more redundancy.

JAI confirms the following network cards.

NIC Manufacture	Type	PCI-X Bus	PCI-Express Bus	
Intel	PRO/1000MT Server Adapter	√	—	32bit or 64bit 33/66/100/133 MHz
Intel	PRO/1000MT Dual Port Server Adapter	√	—	32bit or 64bit 33/66/100/133 MHz
Intel	PRO/1000GT Quad Port Server Adapter	√	—	32bit or 64bit 66/100/133 MHz
Intel	PRO/1000PT Server Adapter	—	√ ( x1 )	2.5Gbps uni-directional 5Gbps bi-directional
Intel	Pro/1000 CT Desktop adaptor	—	√ ( x1 )	2.5Gbps uni-directional 5Gbps bi-directional
Intel	Gigabit ET2 Quad port Server Adapter	—	√ ( x4 )	10Gbps uni-directional 20Gbps bi-directional
Intel	Gigabit ET Dual port Server Adapter	—	√ ( x4 )	10Gbps uni-directional 20Gbps bi-directional
Intel	Gigabit EF Dual port Server Adapter	—	√ ( x4 )	10Gbps uni-directional 20Gbps bi-directional

#### 8.2.4 Hub

It is recommended to use the metal chassis type due to the shielding performance. As the hub has a delay in transmission, please note the latency of the unit.

### 8.3. Recommended Network Configurations

Although the CM-030GE and CB-030GE series conform to Gigabit Ethernet (IEEE 802.3) not all combinations of network interface cards (NICs) and switches/routers are suitable for use with the GigE Vision compliant camera.

JAI will endeavor to continuously verify these combinations, in order to give users the widest choice of GigE components for their system design.

➡ For details of the network settings, please refer to the “Getting Started Guide” supplied with the JAI SDK.

#### 8.3.1 Guideline for network settings

To ensure the integrity of packets transmitted from the camera, it is recommended to follow these simple guidelines:

1. Whenever possible use a peer-to-peer network.
2. When connecting several cameras going through a network switch, make sure it is capable of handling jumbo packets and that it has sufficient memory capacity.
3. Configure inter-packet delay to avoid congestion in network switches.
4. Disable screen saver and power save functions on computers.
5. Use high performance computers with multi-CPU, hyper-thread and 64-bit CPU, etc.
6. Only use Gigabit Ethernet equipment and components together with the camera.
7. Use at least Cat5e and preferably Cat6 Ethernet cables.
8. Whenever possible, limit the camera output to 8-bit.



## CM-030GE/CM-030GE-RA / CB-030GE/CB-030GE-RA

### 8.3.2 Video data rate (network bandwidth)

The video bit rate for CM-030GE/CM-030GE-RA and CB-030GE/CB-030GE-RA is:

Model	Pixel Type	Packet data volume (In case the Packet size is 1500)
CM-030GE/CM-030GE-RA	MONO8	243Mbit/s
	MONO10_PACKED	364Mbit/s
	MONO10	485Mbit/s
CB-030GE/CB-030GE-RA	BAYRG8,BAYGB8	243Mbit/s
	BAYRG10,BAYBG10	485Mbit/s

In case of using Jumbo Frame, the packet data will be improved by 2 %.

For CM-030GE/CM-030GE-RA and CB-030GE/CB-030GE-RA, the jumbo frame can be set at maximum 4040 Bytes (Factory setting is 1440 Bytes). To set Jumbo Frame, refer to chapter 8.2.4.

### 8.3.3 Note for setting packet size

The packet size is set to 1428 as the factory default. Users may enter any value for the packet size and the value will be internally adjusted to an appropriate, legal value that complies with the GenICam standard. The packet size can be modified in the GigE Vision Transport Layer Control section of the camera control tool.

Regarding data transfer rate, a larger packet size produces a slightly lower data transfer rate. The CM-030GE and CB-030GE series can support a maximum of 4040 byte packets provided the NIC being used has a Jumbo Frames function with a setting of a 4040 bytes or larger.

**Caution: Do not set the packet size larger than the maximum setting available in the NIC or switch to which the camera is connected . Doing so will cause output to be blocked.**

### 8.3.4 Calculation of Data Transfer Rate

In order to calculate the data transfer rate, the following parameters and formula are required.

#### Setting parameter

Item	Unit	Symbol
Image Width	[pixels]	A
Image Height	[pixels]	B
Bits per Pixel	[bits]	C
Frame Rate	[fps]	D
Packet Size	[Bytes]	E
Number of Packets (including Data Leader & Trailer Packet)	[packets]	G
Data Transfer Rate	[Mbit/s]	J

#### Fixed value

Item	Unit	value
Data Leader Packet Size	[Bytes]	90
Data Trailer Packet Size	[Bytes]	64

#### Formula to calculate Data Transfer Rate

$$J = \{90 + 64 + (E + 18) * (G - 2)\} * 8 * D / 1000000$$

Where,  $G = \text{ROUNDUP}\{A \cdot B \cdot C / 8 / (E - 36)\} + 2$

The following table shows Bits per Pixel (Item C) which depends on the pixel format.

Pixel format	Bit
Mono8,BAYGR8	8
Mono10_Packed/Mono12_Packed	12
Mono10,Mono12,BayGR10,BAYGR12	16

**Calculation example: CM-140GE Pixel type RGB8**

Item	Unit	Symbol	Setting
Image Width	[pixels]	A	656
Image Height	[pixels]	B	494
Bits per Pixel	[bits]	C	8
Frame Rate	[fps]	D	90
Packet Size	[Bytes]	E	1500
Number of Packets (including Data Leader & Trailer Packet)	[packets]	G	
Data Transfer Rate	[Mbit/s]	J	

$$G = \text{ROUNDUP}\{(656 \times 494 \times 8 / 8 / (1500 - 36))\} + 2 = 222 + 2 = 224$$

$$J = \{90 + 64 + (1500 + 18) \times (224 - 2)\} \times 8 \times 90 / 1000000 = 243 \text{ Mbit/s}$$

**8.3.5 Simplified calculation (Approximate value)**

A simple way to calculate the approximate data transfer rate is the following.  
 Transfer data = Image width (pixel) x Image Height (pixel) x depth per pixel (depending on the pixel format) x frame rate / 1,000,000 (convert to mega bit)

In the case of the CM-030GE with the full image and MONO8 pixel format;  
 The data transfer rate = 656 x 494 x 8 x 90 / 1000000 = 233 Mbit/s

**8.3.6 Note for 100BASE-TX connection**

- ◆ In case of connecting on 100BASE-TX, the maximum packet size should be 1500 byte.
- ◆ In case of connecting on 100BASE-TX, the specifications such as frame rate, trigger interval etc. described in this manual cannot be satisfied.

Pixel Type	Frame rate at Full Frame [fps]
MONO8, BAYRG8, BAYGB8	36.6 ~ 36.8
MONO10_PACKED	24.4
MONO10, BAYRG10, BAYGB10	18.2 ~ 18.4

- ◆ 100BASE-T works in FULL DUPLEX. It does not work in HALF DUPLEX.

## 4.2 8.4. GigE camera connecting examples

### 4.2.1 8.4.1 Using a switching hub for 1 port

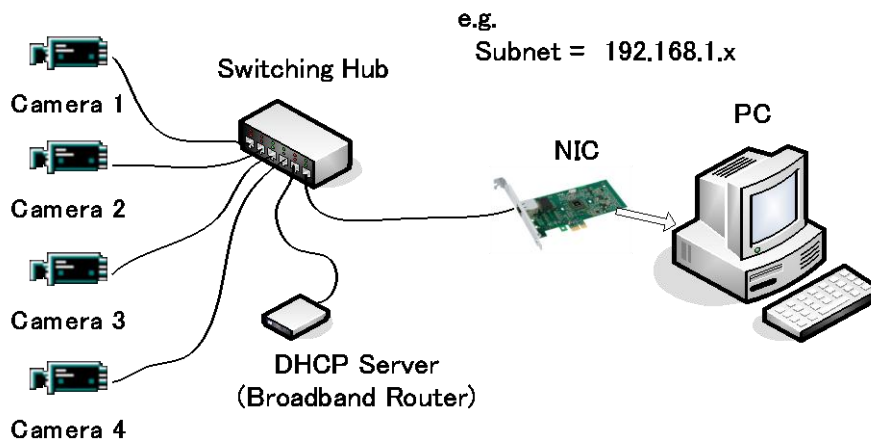

- ◆ All cameras and NIC belong to the same subnet
- ◆ The accumulated transfer rate for all cameras should be within 800Mbps
- ◆ The packet size and the packet delay should be set appropriately in order for the data not to overflow in the switching hub.

### 4.2.2 8.4.2 Connecting a camera to each port of a multi-port NIC

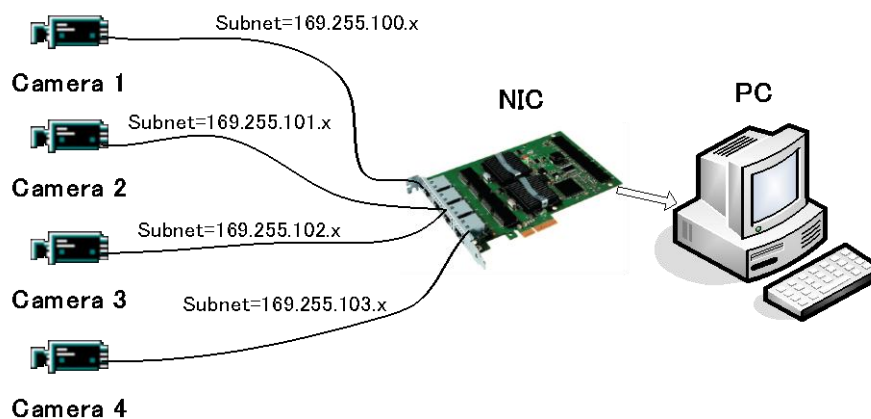

- ◆ This is the example for using a 4-port NIC
- ◆ The pair of the connecting camera and the NIC constructs one subnet. As for the IP configuration, it is appropriate to use the persistent IP.
- ◆ In this case, each camera can use the maximum 800Mbps bandwidth. However, the load for the internal bus, CPU and the application software will be heavy, so a powerful PC will most likely be required.

4.2.3 8.4.3 The data transfer for multiple cameras

4.2.3.1 8.4.3.1 If delayed readout is not used in continuous mode

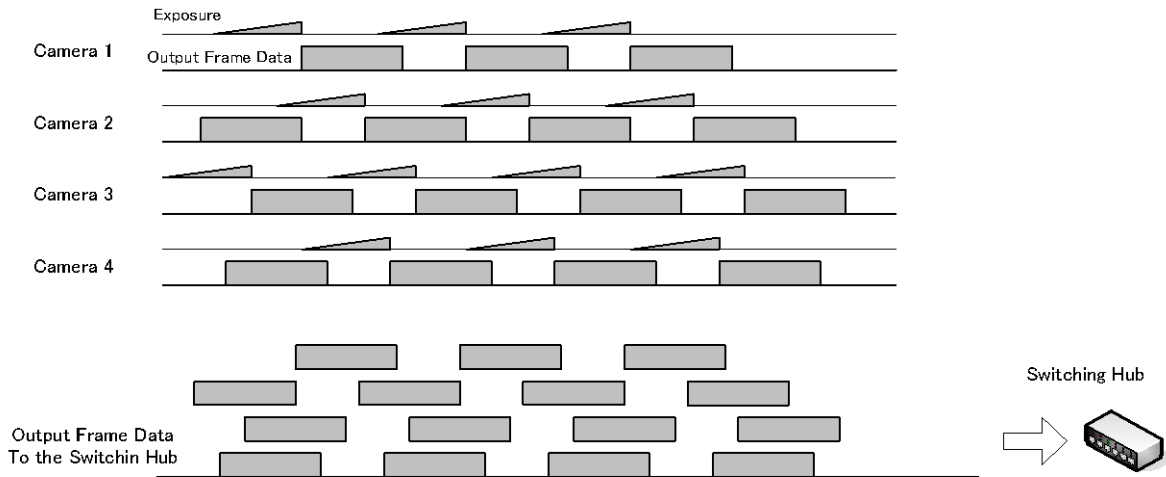

- ◆ The packet delay should be set larger. The data traffic is controlled by the buffer of the hub. It is necessary to check the buffer value of the unit.

4.2.3.2 8.4.3.2 If delayed readout is not used in trigger mode

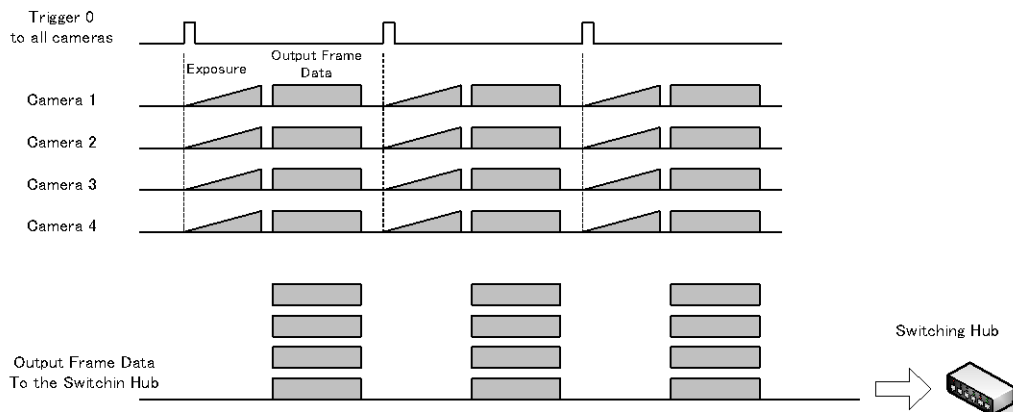

- ◆ The packet delay should be set larger. The data traffic is controlled by the buffer of the hub. It is necessary to check the buffer value of the unit.

4.2.3.3 8.4.3.3 If delayed readout is used

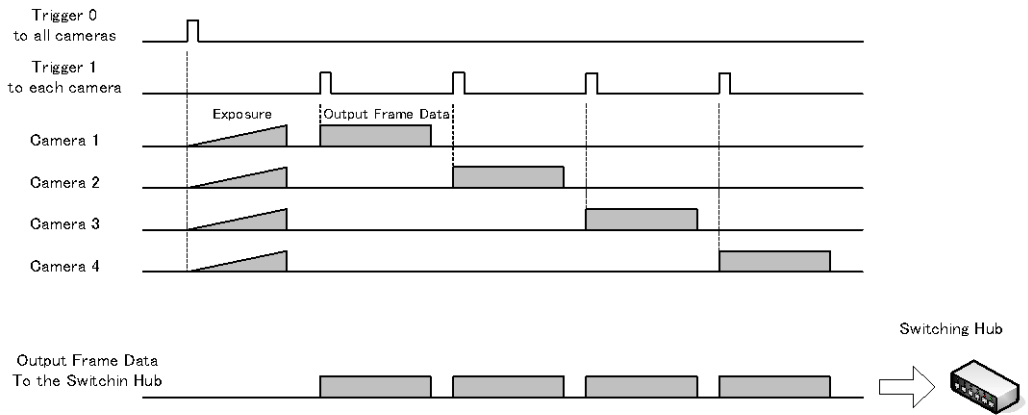

- ◆ The packet delay should be set smaller, and the packet delay trigger controls the data traffic. If the camera has a pulse generator, it can control the data traffic.

## 9. Functions and operations

### 9.1. Basic functions

The CM-030GE/CM-030GE-RA and CB-030GE/CB-030GE-RA cameras are progressive scan cameras with 10 or 8-bit video output in Gigabit Ethernet. An analogue iris video signal (DIP switch select) can be used for controlling auto-iris lenses.

The camera has 2/3, 1/2, 1/4 or 1/8 partial scanning for faster frame rates. Vertical binning is also available.

The camera can operate in continuous mode as well as in 5 triggered modes:

- Edge Pre-select (EPS)
- Pulse width Control (PWC)
- Reset continuous (RCT)
- Sequential trigger (EPS)
- Delayed readout (EPS, PWC)

Depending on the timing of the trigger input in relationship to FVAL (camera internal Frame Valid clock), the start of exposure can be immediate (no-delay, LVAL asynchronous) or delayed until next LVAL (LVAL synchronous).

In the following section the functions are described in detail.

### 9.2. Electronic Shutter

In the GenICam SFNC interface, the electronic shutter is set by Exposure time (microseconds). The traditional JAI method for shutter setting can also be used including JAI Shutter Mode, JAI Preset Shutter, JAI Exposure Time Raw and JAI Exposure Time (us). If setting is done using the SFNC method, these settings are automatically reflected in the traditional JAI settings area.

Exposure Mode	Timed
Exposure Time (us)	40032.00000
Exposure Time Abs (us)	40032.00000
Exposure Time Raw	1251
Pre-dump Mode	Off
<b>d) JAI Acquisition and Trigger Control</b>	
JAI Acquisition Frame Rate	25 fps
JAI Shutter Mode	Preset Shutter
JAI Preset Shutter	Shutter off
JAI Exposure Time Raw	1251
JAI Exposure Time (us)	40032

#### Preset Shutter

10 preset shutter steps are available: OFF (1/90); 1/100, 1/120; 1/250; 1/500; 1/1,000; 1/2,000; 1/4,000; 1/8,000; 1/10,000 sec.

#### Programmable Shutter

It is possible to set the shutter speed in the range of 2L to 511L by 1L unit, in case of Full Frame operation. When 511L is set, it is the equivalent of “OFF (1/90)“ or 11.037ms.

	Minimum Shutter Time 2L	Maximum Shutter Time
Normal	21.6 μs(1L) * 2L = 43.2 μs	21.6 μs * 511L ≈ 11.037 ms
V Binning	23.4 μs * 2L = 46.8 μs	23.4 μs * 257L ≈ 6.0138 ms

#### Pulse Width Control

With this mode selected the exposure time is controlled by the width of the trigger pulse. The minimum trigger pulse width is equal to 1L (21.6 μs)

**Exposure Time Abs (GenICam Standard)**

This is a function specified in the GenICam standard.

The shutter speed can be entered as an absolute exposure time in microseconds (µs) in register address 0xA018. The entered absolute time (Time Abs) is then converted to programmable exposure (PE) value inside the camera.

The below equations show the relationship between the PE value used by the camera for the different readout modes and the "Exposure Time Abs" value entered in register 0xA018.

As the calculation is based on rounding down to the closest integer, precise values may not always occur.

The relation between PE value and Time Abs:

Normal readout PE= 2 + INT<sup>(1)</sup> (Exposure time -43) µs / (864<sup>(2)</sup>/40000000<sup>(3)</sup>)

V Binning readout PE= 2 + INT (Exposure time -46) µs / (936/40000000)

Note: (1) INT means integer (rounded down). (2) Pixel clocks/line. (3) Pixel clock

The following table shows minimum value and maximum value for each readout mode.

	Minimum value	Maximum Value
Normal Scan	43 us	11,038 us 511L
2/3 Partial Scan	43 us	7,733 us 358L
1/2 Partial Scan	43 us	6,221 us 288L
1/4 Partial Scan	43 us	3,867 us 179L
1/8 Partial Scan	43 us	2,722 us 126L
V-Binning Scan	46 us	6,013 us 257L

**GPIO in combination with Pulse Width Trigger**

More precise exposure time can be obtained by using GPIO in combination with Pulse Width Trigger mode. The clock generator and counter can be programmed in very fine increments.

As for the setting example, refer to chapter 6.5.1.

**4.3 9.3. Auto-detect LVAL-sync / a-sync. accumulation**

This function replaces the manual setting found in older JAI cameras. Whether accumulation is synchronous or a-synchronous in relationship to LVAL depends on the timing of the trigger input.

When trigger is received while FVAL is high (during readout), the camera works in LVAL-synchronous mode, preventing reset feed trough in the video signal. There is a maximum jitter of one LVAL period from issuing a trigger and accumulation start.

If trigger is received when FVAL is low, the cameras works in LVAL-asynchronous mode (no delay) mode. This applies to both pre-select (PS) trigger mode and pulse width trigger (PW) mode.

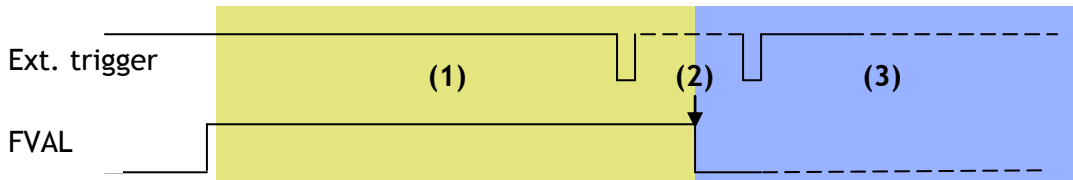

- (1) In this period camera executes trigger at next LVAL (prevents feed-through noise)
- (2) Avoid trigger at FVAL transition (+/- 1 LVAL period), as the function may randomly switch between "next LVAL" and "immediate".
- (3) In this period camera executes trigger immediately (no delay)

Fig. 27. Auto-detect LVAL sync /a-sync accumulation

## 5. 10. Operation Modes

The CM-030GE and CB-030GE series comply with GenICam SFNC (Standard Features Naming Convention) version 1.3 and the acquisition of the image, the trigger functions, the exposure settings and so on are different from those used in early versions of these cameras.

**Note:** In this section, the GUI shown is from the CB-200GE.

### 5.1 10.1. The functions related to GenICam SFNC 1.3

The following functions are the most affected by SFNC 1.3.

Features - Acquisition and Trigger Control

Acquisition mode

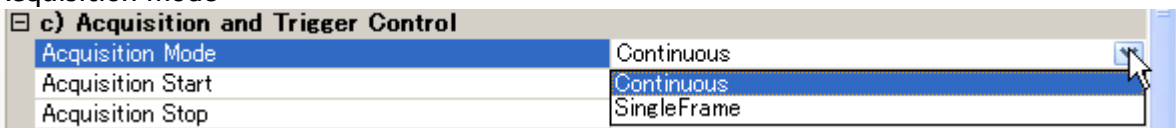

The image can be captured in two ways, continuous or single frame.

① Continuous

By executing AcquisitionStart command, the image can be output until AcquisitionStop Trigger is input.

② Single Frame

By executing AcquisitionStart command, one frame of the image can be output and then the acquisition is stopped.

Trigger Selector



This can be selected from FrameStart or TransferStart.

① FrameStart

The trigger pulse can take one frame capture.

② TransferStart

The trigger pulse can read out the image stored in the frame memory. This is used for the delayed Readout

TriggerMode

This selects either trigger mode (ON) or continuous mode (OFF).

TriggerSoftware

This is one of the trigger sources which enables trigger commands to be created using software. In order to use TriggerSoftware, TriggerSource should be set at Software.

TriggerSource

The trigger source can be selected from the following signals.



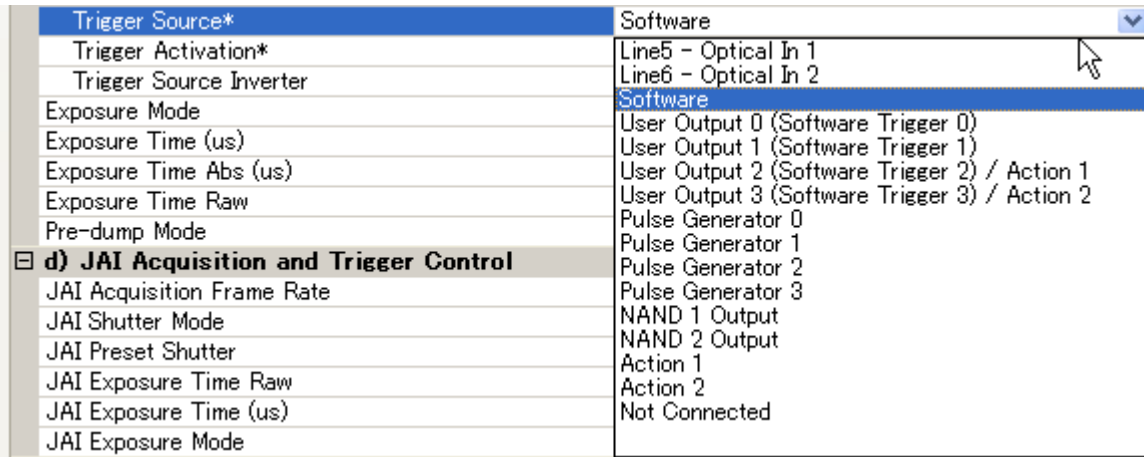

TriggerActivation

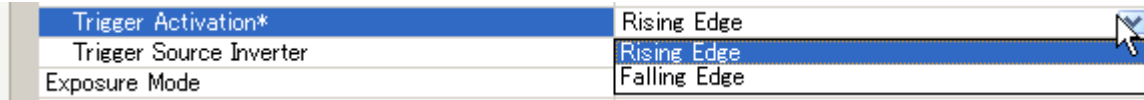

This can set how the trigger is activated.

- ① RisingEdge: The trigger is effective at the rising edge of the pulse.
- ② FallingEdge: The trigger is effective at the falling edge of the pulse.

ExposureMode

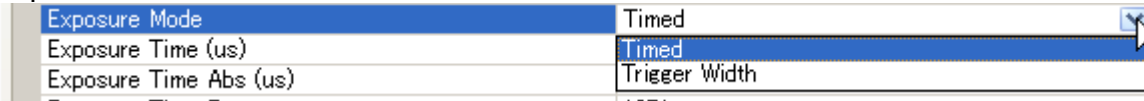

This can select the exposure mode.

- ① Timed: The exposure is set in units of  $\mu$  seconds or lines.
- ② TriggerWidth: The exposure is the same as the trigger width.

The CM-030GE and CB-030GE series have a JAI Acquisition and Trigger Control function which is the same as used for previous models and includes 7 types of exposure modes.

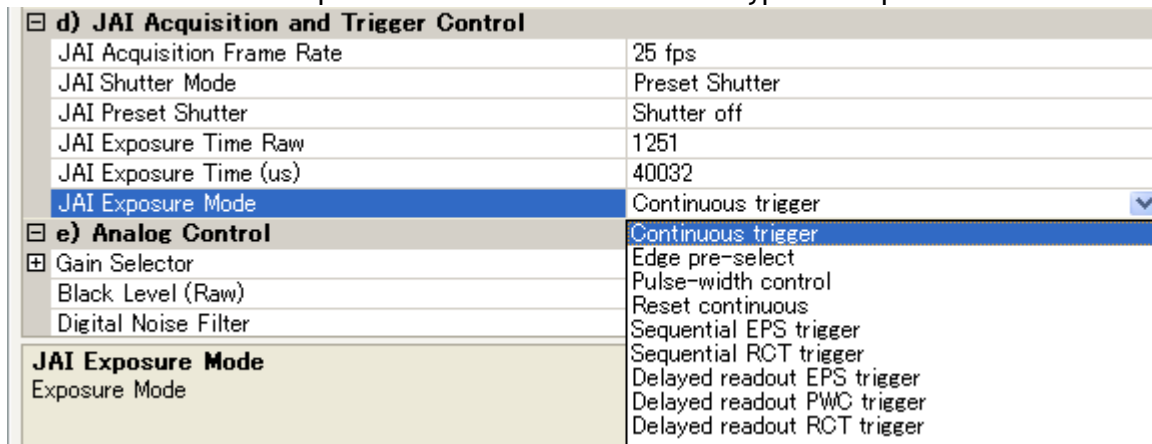

Acquisition and Trigger Control and JAI Acquisition and Trigger Control are linked to each other and if the one is set, the setting parameters are reflected in the other.

The following is an example: when JAI Acquisition and Trigger Control is set at EPS, TriggerMode is automatically set ON and ExposureMode is set to Timed.

The exposure time can be set in the JAI Shutter Mode by selecting either lines or microseconds and the setting values are reflected in the same items of Acquisition and Trigger Control.

c) Acquisition and Trigger Control	
Acquisition Mode	Continuous
Acquisition Start	Push to Execute Command ---->
Acquisition Stop	Push to Execute Command ---->
Trigger Selector*	Frame Start
Trigger Mode*	On
Trigger Software*	Push to Execute Command ---->
Trigger Source*	Software
Trigger Activation*	Rising Edge
Trigger Source Inverter	False
Exposure Mode	Timed
Exposure Time (us)	24736.00000
Exposure Time Abs (us)	24736.00000
Exposure Time Raw	773
Pre-dump Mode	Off
d) JAI Acquisition and Trigger Control	
JAI Acquisition Frame Rate	25 fps
JAI Shutter Mode	Programmable Exposure in lines
JAI Preset Shutter	Shutter off
JAI Exposure Time Raw	773
JAI Exposure Time (us)	20720
JAI Exposure Mode	Edge pre-select

Other parameters such as trigger signal should be set in Acquisition and Trigger Control.

The following description uses JAI Acquisition and Trigger Control and the operation mode can be selected in JAI Exposure Mode.

d) JAI Acquisition and Trigger Control	
JAI Acquisition Frame Rate	25 fps
JAI Shutter Mode	Preset Shutter
JAI Preset Shutter	Shutter off
JAI Exposure Time Raw	1251
JAI Exposure Time (us)	40032
JAI Exposure Mode	Continuous trigger
e) Analog Control	
Gain Selector	Edge pre-select
Black Level (Raw)	Pulse-width control
Digital Noise Filter	Reset continuous
JAI Exposure Mode	Sequential EPS trigger
	Sequential RCT trigger
	Delayed readout EPS trigger
	Delayed readout PWC trigger
	Delayed readout RCT trigger

## 10.2. Operation Mode

This camera can operate in 6 primary modes.

- |  |                                 |
|--|---------------------------------|
| 1. <b>Continuous Mode</b>                  | Pre-selected exposure           |
| 2. <b>Pre-select trigger mode</b>          | Pre-selected exposure           |
| 3. <b>Pulse Width Control trigger mode</b> | Pulse width controlled exposure |
| 4. <b>Reset Continuous trigger mode</b>    | Pre-selected exposure           |
| 5. <b>Sequential Trigger</b>               | Pre-selected exposure           |
| 6. <b>Delayed Readout Trigger</b>          | Pre-selected exposure,PWC       |

### 10.2.1 Continuous operation

For applications not requiring asynchronous external trigger, but where a continuous stream of images is required, this mode should be used.

In this mode it is possible to use a lens with video controlled iris.

For timing details, refer to fig. 19. through fig. 24.

To use this mode:

c) Acquisition and Trigger Control	
Acquisition Mode	Continuous
Acquisition Start	Push to Execute Command ---->
Acquisition Stop	Push to Execute Command ---->
Trigger Selector*	Frame Start
Trigger Mode*	Off
Trigger Software*	Push to Execute Command ---->
Trigger Source*	Software
Trigger Activation*	Rising Edge
Trigger Source Inverter	False
Exposure Mode	Timed
Exposure Time (us)	24736.00000
Exposure Time Abs (us)	24736.00000
Exposure Time Raw	773
Pre-dump Mode	Off
d) JAI Acquisition and Trigger Control	
JAI Acquisition Frame Rate	25 fps
JAI Shutter Mode	Programmable Exposure in lines
JAI Preset Shutter	Shutter off
JAI Exposure Time Raw	773
JAI Exposure Time (us)	20720
JAI Exposure Mode	Continuous trigger

### 10.2.2 Edge Pre-select Trigger Mode

An external trigger pulse initiates the capture, and the exposure time (accumulation time) is the fixed shutter speed set by registers. The accumulation can be LVAL synchronous or LVAL a-synchronous.

The resulting video signal will start to be read out after the selected shutter time.

For timing details, refer to fig. 19. through fig.24 and figures 28 and 29.

To use this mode:

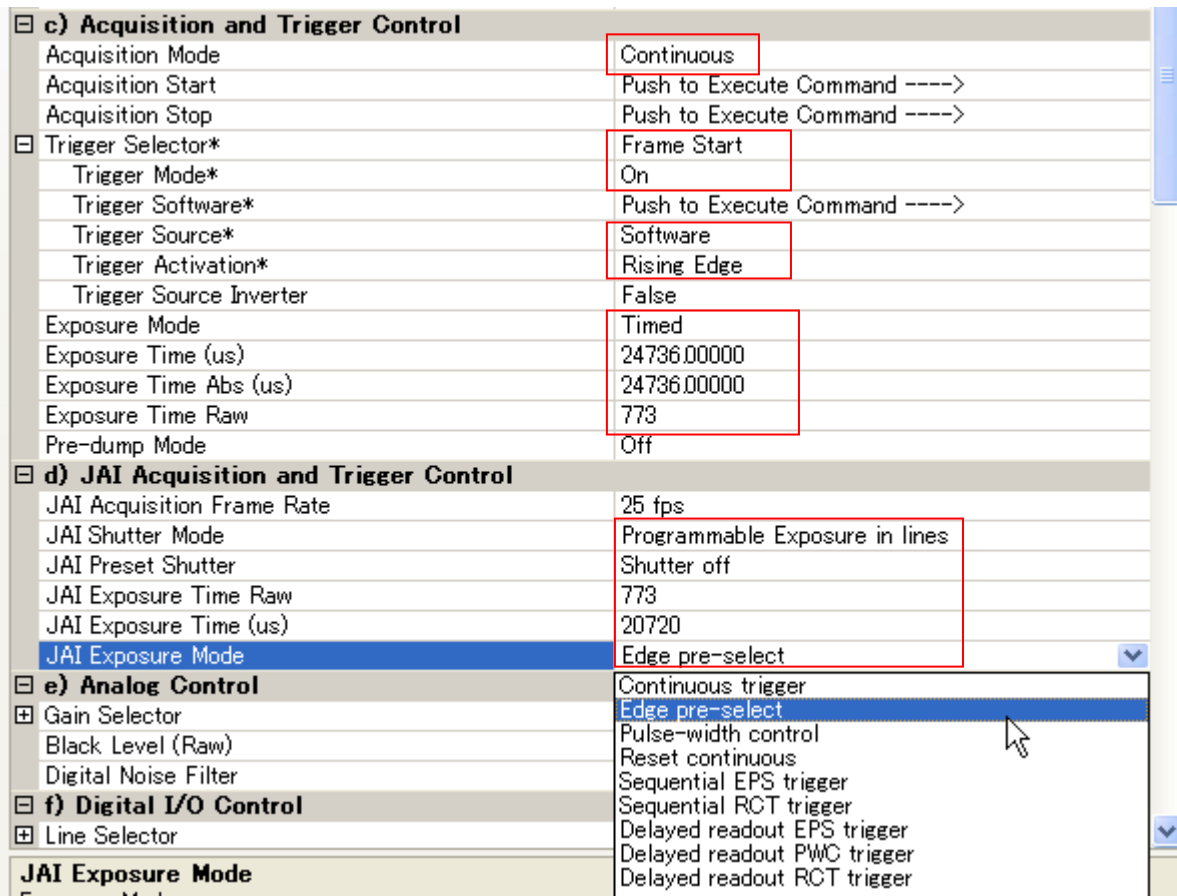

#### Important notes on using this mode

- Trigger pulse >2 LVAL to <1 FVAL)
- The following table shows minimum trigger interval in synchronous accumulation mode

Full scan	513 L
2/3 partial	363 L
1/2 Partial	293 L
1/4 Partial	184 L
1/8 Partial	131 L
1/2 V Binning	260 L

- 1) In case of a-synchronous mode, the exposure time should be added to the above table.
- 2) In order to keep the minimum trigger interval in partial scan mode, a exposure time should be set within a number of normal read out line(511L). If it is exceeded, the minimum trigger interval is longer by (exposure time - 511L).

10.2.2.1 LVAL\_sync timing

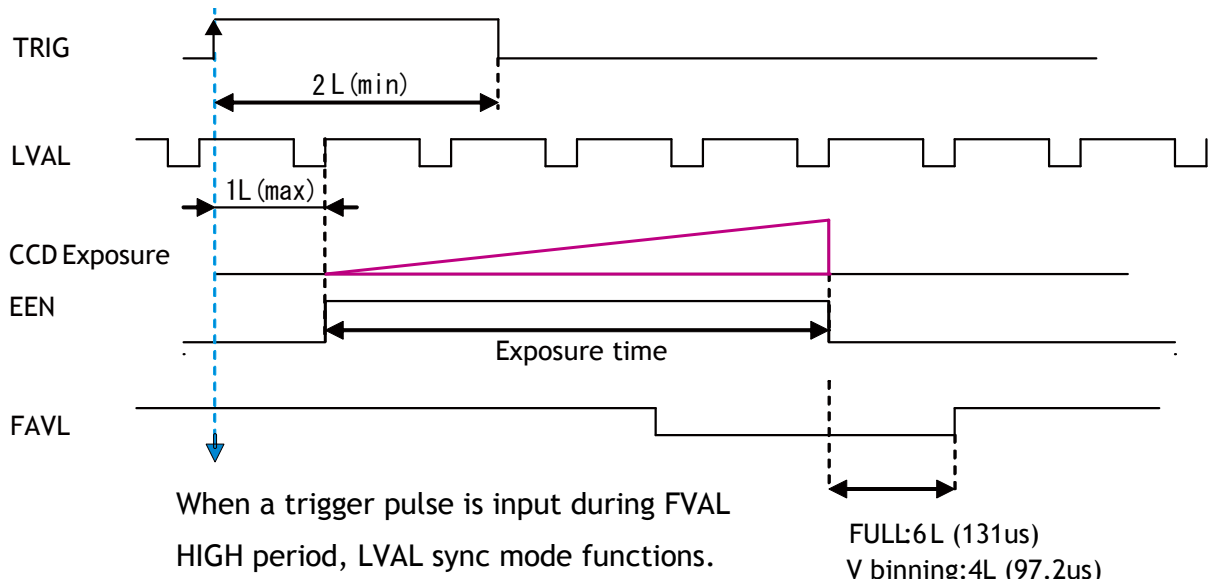

Fig. 28 Edge Pre-select LVAL sync Timing

10.2.2.2 LVAL\_async timing

LAVL ASYNC

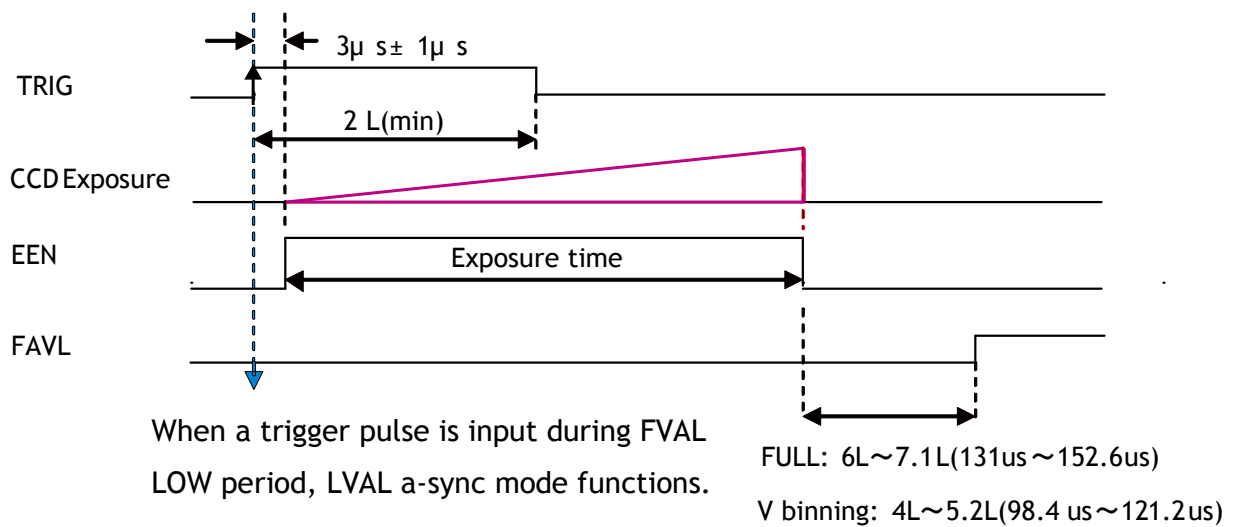

Fig.29. Edge Pre-select LVAL a-sync Timing

### 10.2.3 Pulse Width Control trigger mode

In this mode the accumulation time is equal the trigger pulse width. Here it is possible to have long time exposure. The maximum recommended time is <2 seconds.

The accumulation can be LVAL synchronous or LVAL a-synchronous.

The resulting video signal will start to be read out after the trigger rising edge.

For timing details, refer to fig. 19. through fig. 24 and fig. 30 through 31.

To use this mode:

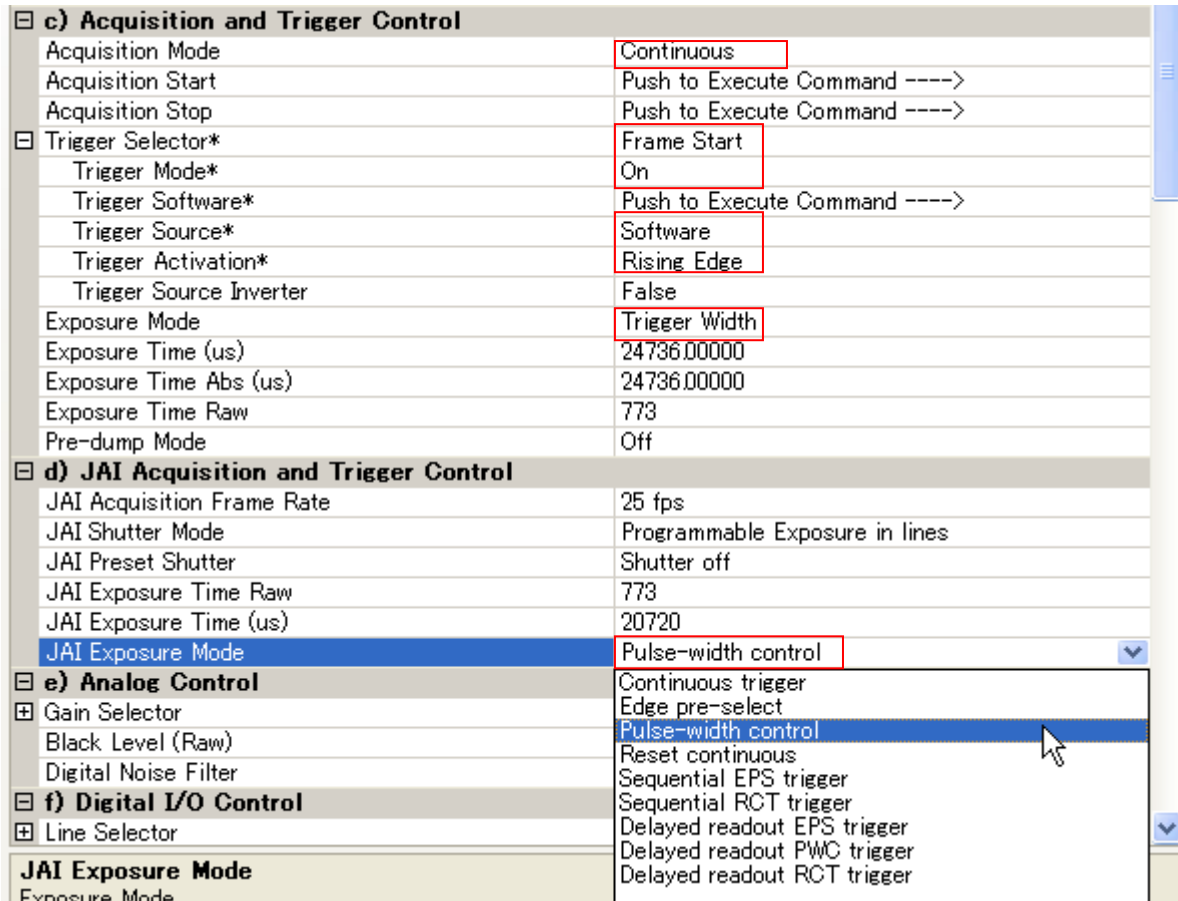

#### Important notes on using this mode

- Trigger pulse width >2 LVAL to <2 seconds
- The following table shows minimum trigger interval in synchronous accumulation mode

Full scan	513 L
2/3 Partial	363 L
1/2 Partial	293 L
1/4 Partial	184 L
1/8 Partial	131 L
V Binning	260 L

- 1) In case of a-synchronous mode, the exposure time should be added to the above table.
- 2) In order to keep the minimum trigger interval in partial scan mode, a exposure time should be set within a number of normal read out line(511L). If it is exceeded, the minimum trigger interval is longer by (exposure time - 511L).

10.2.3.1 LVAL\_sync timing

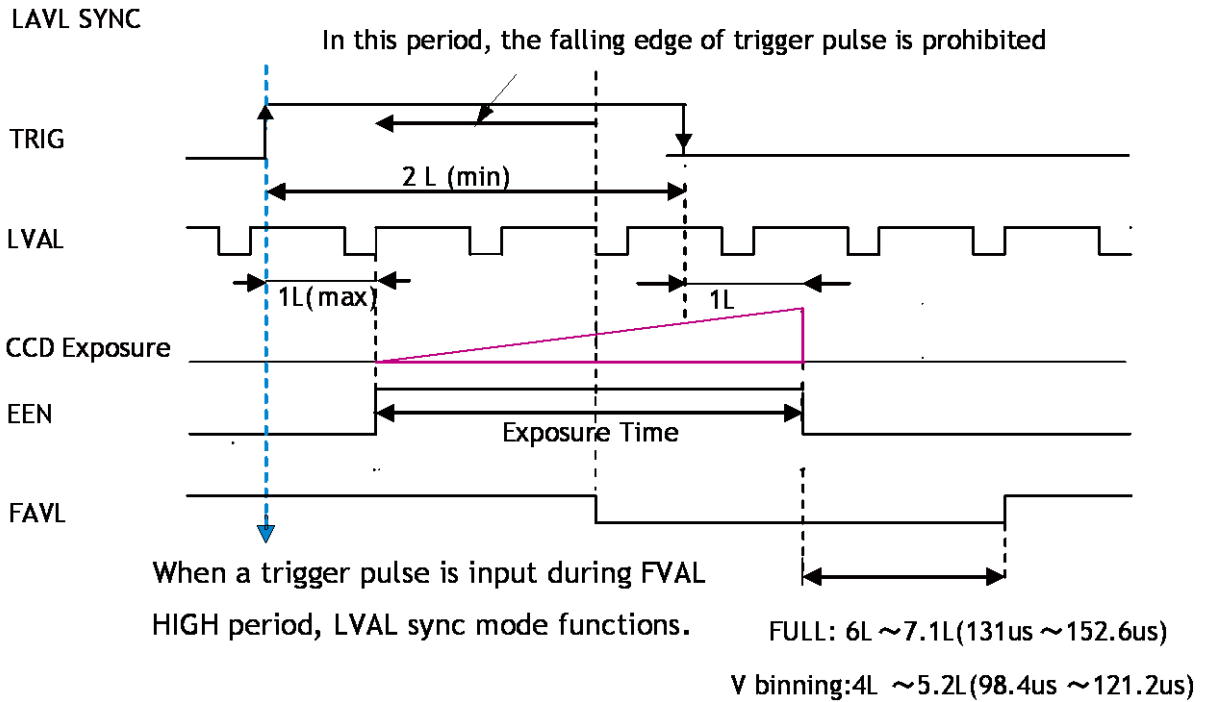

Fig. 30 Pulse width control. LVAL sync

10.2.3.2 LVAL\_async timing

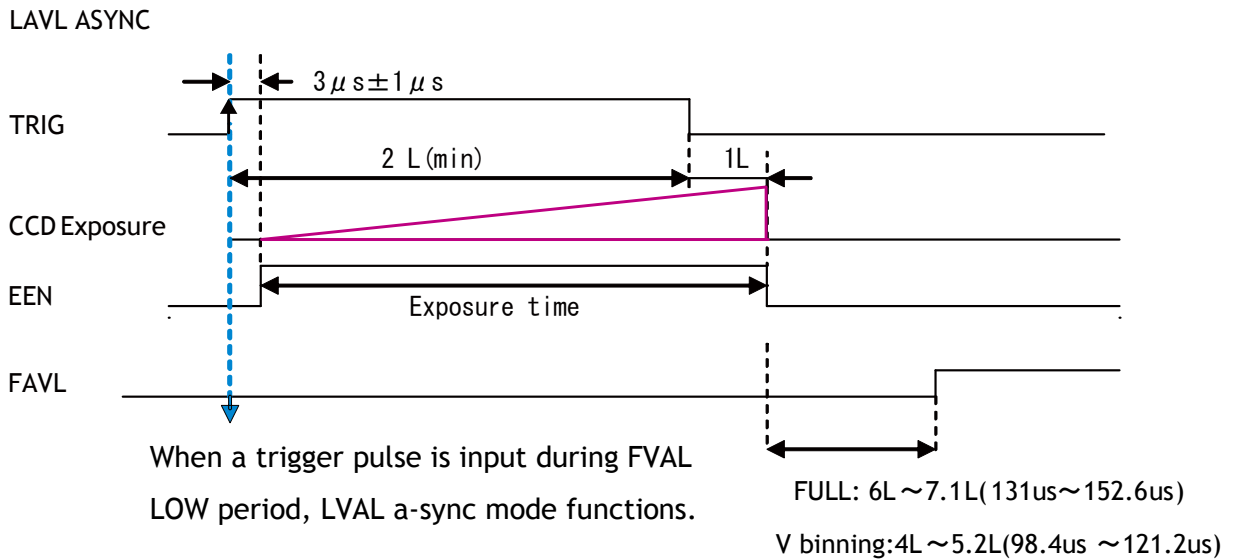
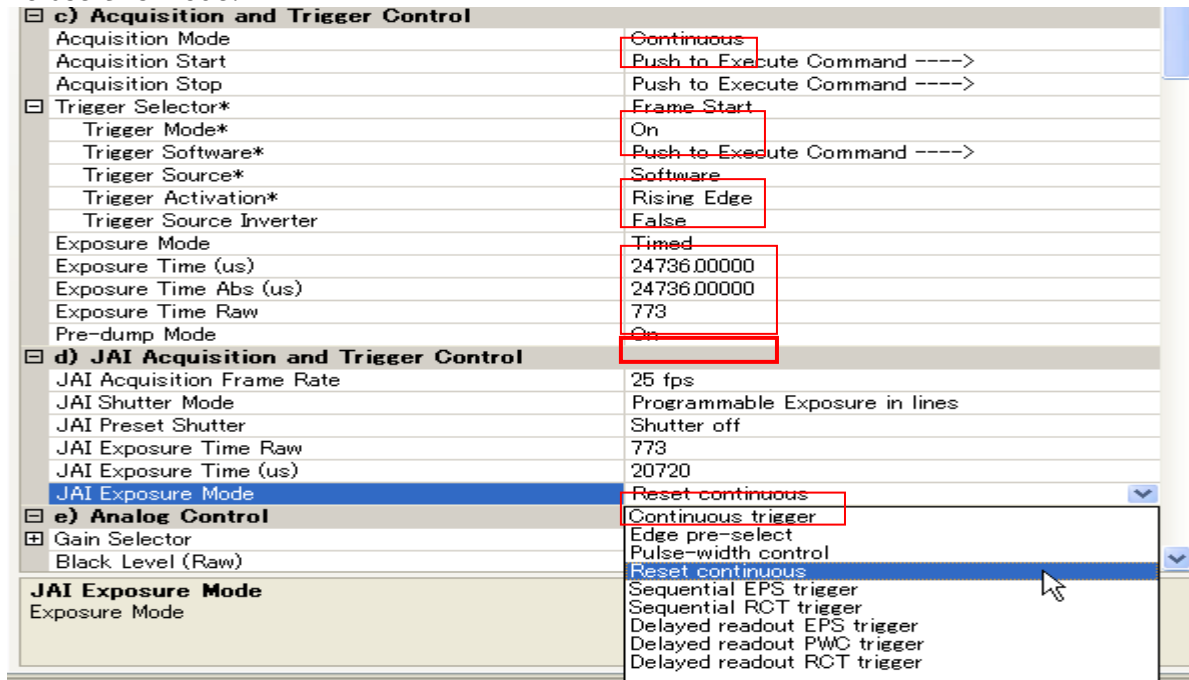

Fig.31. Pulse Width control LVAL a-sync

### 10.2.4 Reset Continuous (RCT) trigger mode

The RCT mode operates like EPS (edge preselect) mode with smearless function. An external trigger pulse will immediately stop the video read out, reset and restart the exposure, then operate as normal mode until the next trigger. After the trigger pulse is input, a fast dump read out is performed. In the CM-030GE/ CB-030GE, this period is 1.3608ms which is 63L. The exposure time is determined by the pre-set shutter speed. If no further trigger pulses are applied, the camera will continue in normal mode and the video signal is not output. The fast dump read out has the same effect as “smearless read out”. Smear over highlight areas is reduced for the trigger frame. The reset continuous trigger mode makes it possible to use triggering in conjunction with a lens with video controlled iris.

To use this mode:



#### Important notes on using this mode

- Trigger pulse >2 LVAL to <1 FVAL)
- The following table shows minimum trigger interval in asynchronous accumulation mode

Full scan	579 L
2/3 Partial	426 L
1/2 Partial	356 L
1/4 Partial	247 L
1/8 Partial	194 L
1/2 V Binning	326 L



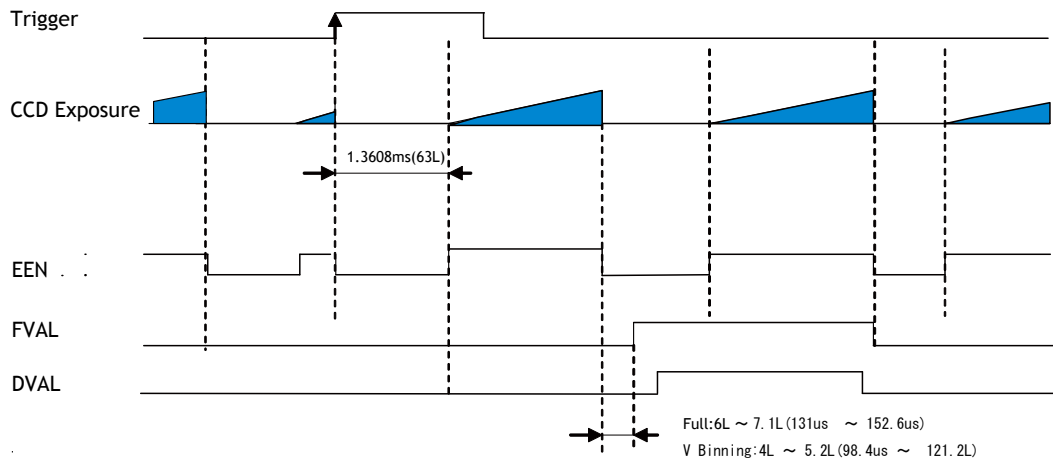

Note: When PE is set at 511 or the shutter is set at OFF, EEN is always HIGH.

Fig.32. RCT mode timing

### 10.2.5 Sequential Trigger Mode (Pre-Select trigger)

The ROI, Shutter and Gain values can be preset up to 10 sequences. Along with every trigger input, the image data with the preset sequence is output as described below.

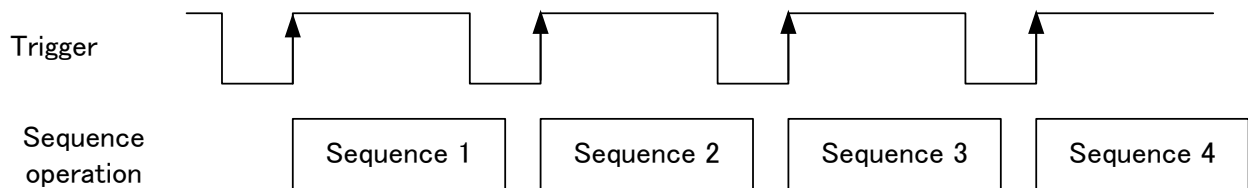

Signals added to trigger can be selected by Trigger Source. The camera will functions on the rising edge of the trigger and Negative or Positive should be determined accordingly.

For the sequence, the following default settings are installed.

ID	ROI				Shutter	Gain
	Width	Height	Offset X	Offset Y		
1	656	494	0	0	511	0
2	656	494	0	0	511	0
3	656	494	0	0	511	0
4	656	494	0	0	511	0
5	656	494	0	0	511	0
6	656	494	0	0	511	0
7	656	494	0	0	511	0
8	656	494	0	0	511	0
9	656	494	0	0	511	0
10	656	494	0	0	511	0

In the case of Sequential EPS, (Trigger source is Software)

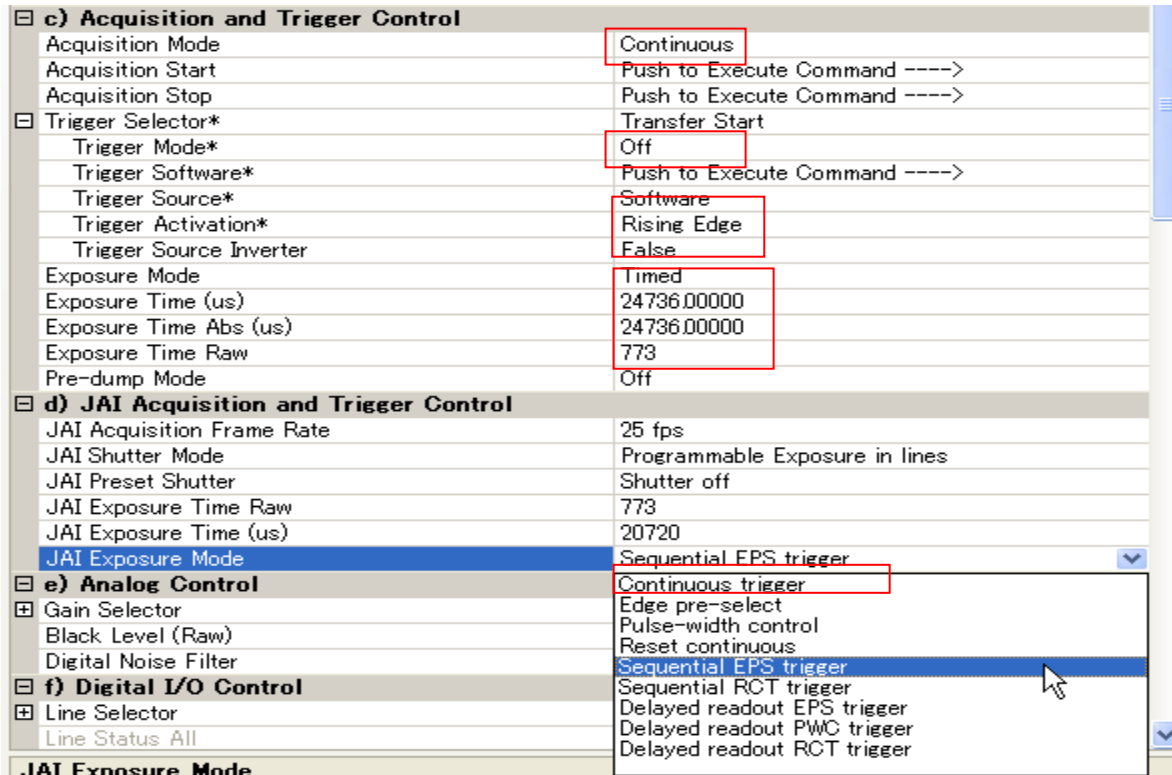

For each sequence,

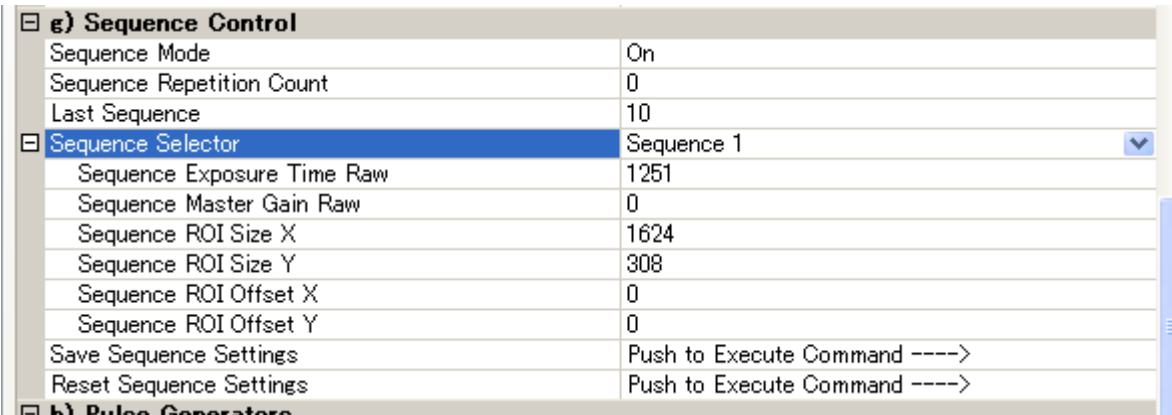

The following table shows the minimum trigger interval in synchronous accumulation mode. In case of a-synchronous accumulation mode, the exposure time should be added to figures in this table.

Full Scan	2/3Partial	1/2 Partial	1/4 Partial	1/8 Partial	1/2 V Binning
514 L	364 L	294 L	185 L	132 L	261 L

- ◆ The conditions for this table are that the shutter speed should be set the same for all sequences.  
If the shutter speed is different, the difference of exposure time should be added. It is recommended to set the exposure time in the order from the shortest to the longest one.
- ◆ The minimum trigger interval is > Exposure time (expressed in L(Line)) + FVAL on Normal scan ( 511L ) + 1L )
- ◆ Do not input the trigger just after the sequence is reset. It requires at least 500ms delay.
- ◆ In sequential mode, the exposure should be adjusted so that the LVAL a-sync mode can always be functioned.

10.2.6 Delayed Readout Mode (Pre-Select, Pulse width control)

This mode can be used to delay the transmission of a captured image. When several cameras are triggered simultaneously and connected to the same GigE interface, it allows the cameras to be read out in sequence, preventing congestion.

The image data is not transmitted directly by the trigger 0 and it is stored in the memory located at Ethernet Interface. By the falling edge of the soft trigger 1, the image data is output.

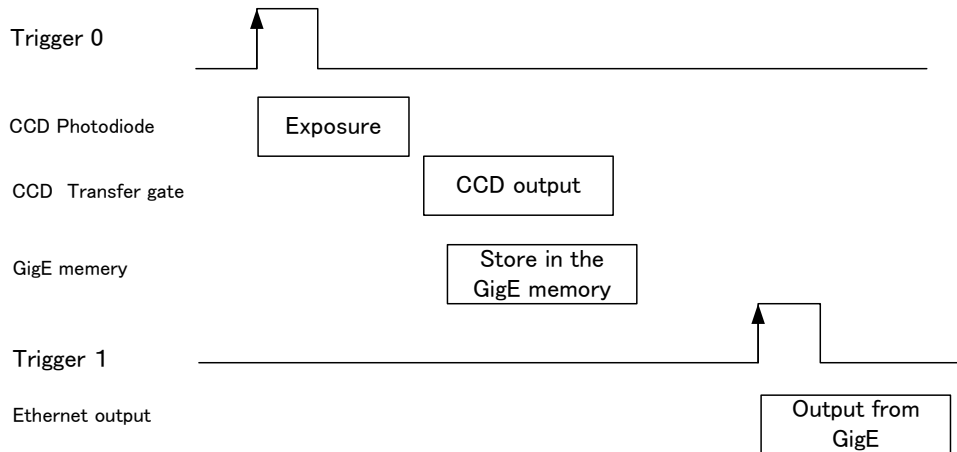

Trigger settings;

<b>c) Acquisition and Trigger Control</b>	
Acquisition Mode	Continuous
Acquisition Start	Push to Execute Command ---->
Acquisition Stop	Push to Execute Command ---->
Trigger Selector*	Transfer Start
Trigger Mode*	On
Trigger Software*	Push to Execute Command ---->
Trigger Source*	Software
Trigger Activation*	Rising Edge
Trigger Source Inverter	False
Exposure Mode	Timed
Exposure Time (us)	24736.00000
Exposure Time Abs (us)	24736.00000
Exposure Time Raw	773
Pre-dump Mode	Off
<b>d) JAI Acquisition and Trigger Control</b>	
JAI Acquisition Frame Rate	25 fps
JAI Shutter Mode	Programmable Exposure in lines
JAI Preset Shutter	Shutter off
JAI Exposure Time Raw	773
JAI Exposure Time (us)	20720
JAI Exposure Mode	Delayed readout EPS trigger
<b>e) Analog Control</b>	
Gain Selector	Continuous trigger
Black Level (Raw)	Edge pre-select
Digital Noise Filter	Pulse-width control
<b>f) Digital I/O Control</b>	
Line Selector	Reset continuous
Line Status All	Sequential EPS trigger
	Sequential RCT trigger
	Delayed readout EPS trigger
	Delayed readout PWC trigger
	Delayed readout RCT trigger
<b>JAI Exposure Mode</b>	

When the image stored is transferred, the trigger source should be set at Transfer Start  
 When the trigger pulse is input, the image is output.

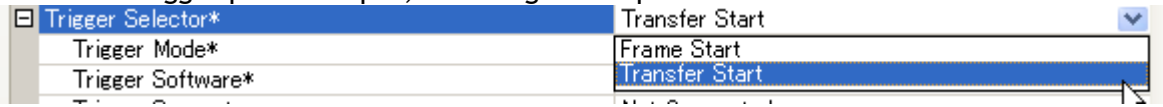

### 10.2.7 Optical Black transfer mode

It is possible for the user to decide whether the optical black (OB) portion of the image will be transferred or not. The optical black part can be used for black reference in the application software.

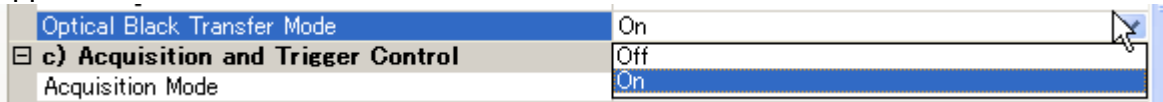

	OB Transfer Mode OFF	OB Transfer Mode ON
Normal Scan		
2/3 Partial Scan		
1/2 Partial Scan		
1/4 Partial Scan		
1/8 Partial Scan		
V Binning Scan		

## CM-030GE/CM-030GE-RA / CB-030GE/CB-030GE-RA

### 10.2.8 Operation Mode and Functions matrix

ID (Value) Note 1	Mode	Shutter Preset / Program.	Vertical Binning Note 1	Partial Scanning	LVAL Sync/Async	Auto Iris output
0x00	Continuous	Yes	Yes	Yes	---	Yes ( Note 2)
0x01	Pre-select (PS)	Yes	Yes	Yes	Auto	No
0x02	Pulse Width (PW)	Not applicable	Yes	Yes	Auto	No
0x03	Reset Continuous (RCT)	Yes	Yes	Yes	Async only	Yes ( Note 2)
0x09	Sequential Pre-select (EPS)	Yes	Yes	Yes	Async only	No
0x17	Pre-Select Delayed Readout	Yes	Yes	Yes	Auto	No
0x18	Pulse width Delayed Readout	Not applicable	Yes	Yes	Auto	No

Note 1: Vertical Binning is available for only CM-030GE/CM-030GE-RA.

Note 2: Auto iris output is available only on Continuous mode and RCT with full resolution or with vertical binning. It cannot be used with partial scan mode.

## 11. JAI control tool

In this section, the general operation of the JAI control tool is explained. For more regarding the JAI control tool, please refer to the JAI control tool documentation in the JAI SDK.

### 11.1. About GenICam™SFNC1.3

The CM-030GE and CB-030GE series are now redesigned as conforming to GenICam SFNC1.3. GenICam SFNC stands for GenICam Standard Features Naming Convention. By defining the standard cases and the standard features, general-purpose software can control cameras from any manufacturers which conform to the GenICam standard.

JAI, in the past, used traditional feature names in order to maintain naming continuity with previous cameras. However, new revisions of cameras comply with GenICam SFNC feature names, even though the traditional feature names are still maintained.

Terminologies used for functions will be much different from previous models. This manual explains the basic operation using feature names specified in the GenICam SFNC 1.3 specification.

The latest version of JAI GigE Vision cameras comply with GenICam SFNC1.3. However, JAI can offer the following options for customers who use older versions of GigE Vision cameras.

JAI provides the following software.

1. Version prior to SFNC 1.3 for older camera version
2. Downgrade to old version from the latest SFNC 1.3 version

Please contact local sales representatives for the details

### 11.2. JAI SDK Ver. 1.3

JAI SDK has also been upgraded to version 1.3.

In a GigE Vision compliant camera, all features are described in the XML file inside the camera and after connecting JAI Control Tool software, all features are downloaded to the JAI Control Tool software. If customers use older versions of cameras together with the Control Tool software ver.1.3, feature properties shown in the Control Tool exhibit old feature names, enabling customers to operate cameras in a familiar way.

If the latest version of the camera is connected, some traditional JAI feature names such as JAI Preset Shutter, will display in the Feature Properties in addition to the newer GenICam SFNC 1.3 names.

These features can be set as usual and settings for those features are reflected automatically in the GenICam SFNC 1.3 feature names.

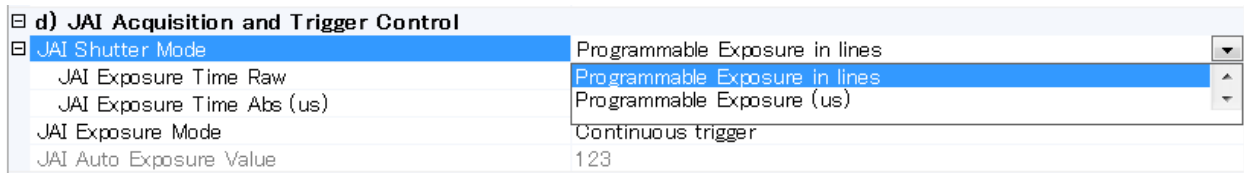

The features shown above will vary depending on the specific camera.

### 11.3. Examples of camera operation

The following descriptions are based on GenICam SFNC 1.3.

#### 11.3.1 Generic cautions for operation

1. The parameters in the gray part of the control tool cannot be changed.
2. If the image size is changed, the acquisition should be stopped and parameters

set for

determining the size.

#### 11.3.2 Connection of camera(s)

Connect camera(s) to Network. After establishing the connection, start the control tool.

The model name connected to the Network is displayed with connecting icon.



When this icon is double-clicked, the camera can communicate with the camera control tool and the icon is changed.

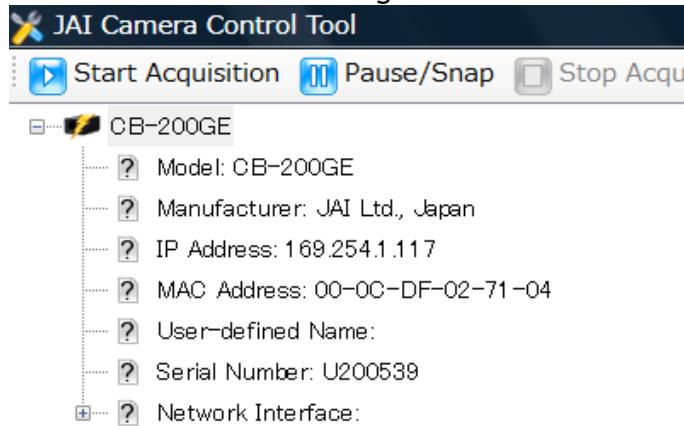

#### 11.3.3 Camera setting level

The setting level has three layers: beginner, expert and guru. Guru level includes the most sophisticated functions.

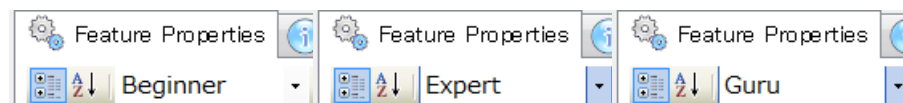

## 11.4. Input and Output settings

### 11.4.1 Interfacing with external devices

For interfacing with external devices, the relationship between Line in/out (Digital I/O) and the external terminal is fixed. Please refer to エラー! 参照元が見つかりません。.

f) Digital I/O Control	
Line Selector	Line3 - Optical Out 1
Line Status All	Line3 - Optical Out 1
User Output Selector	Line4 - Optical Out 2
Software Trigger 0	Line5 - Optical In 1
Software Trigger 1	Line6 - Optical In 2
Software Trigger 2	TimeStamp Reset
Software Trigger 3	NAND 1 In 1
g) Sequence Control	
Sequence Mode	NAND 1 In 2
Sequence Identifies Count	NAND 2 In 1
	NAND 2 In 2

In the camera control tool, it is displayed as Line 1 -TTL Out1.

### 11.4.2 Setting of input and output

#### 11.4.2.1 How to assign the signal to Line

This function decides which signal is assigned to Digital I/O (Line 1 to Line 8).

The following is the example to set Line5 - Opt In 1. In this case, the line source is the signal connected to Opt In 1. The line format is automatically set to Opto Coupled.

d) Digital IO Control	
Line Selector	Line5 - Opt In 1
Line Mode	Input
Line Inverter	False
Line Status	False
LineSource	FrameActive
Line Format	Opto Coupled
User Output Selector	No Connect
User Output Value	TTL
e) Counter And Timer Control	
Counter Selector	LVDS
Timer Selector	Opto Coupled
f) Event Control	

The following is the example to set the output signal. It selects the output signal from Line3 - Optical Out 1 from Line source. In the following example, Exposure Active signal is output. As the line format, TTL is automatically selected.



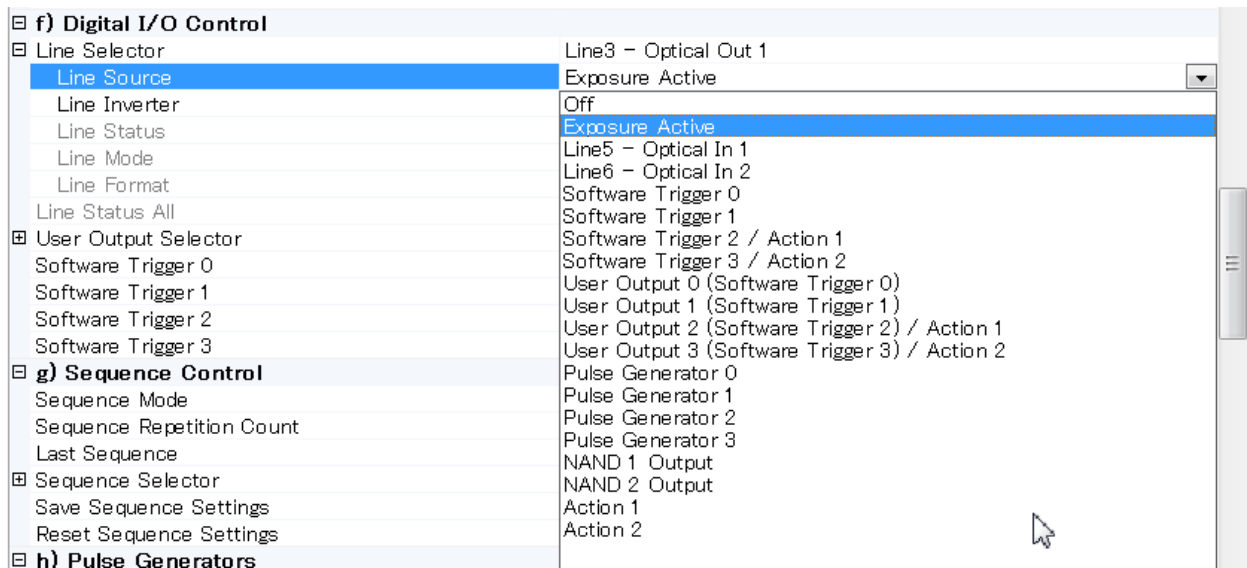

### 11.4.2.2 Selecting of Trigger Source

The trigger signal is chosen by TriggerSource of TriggerSelector in Acquisition Control. In the following example, pulse generator 0 is selected as the trigger signal.

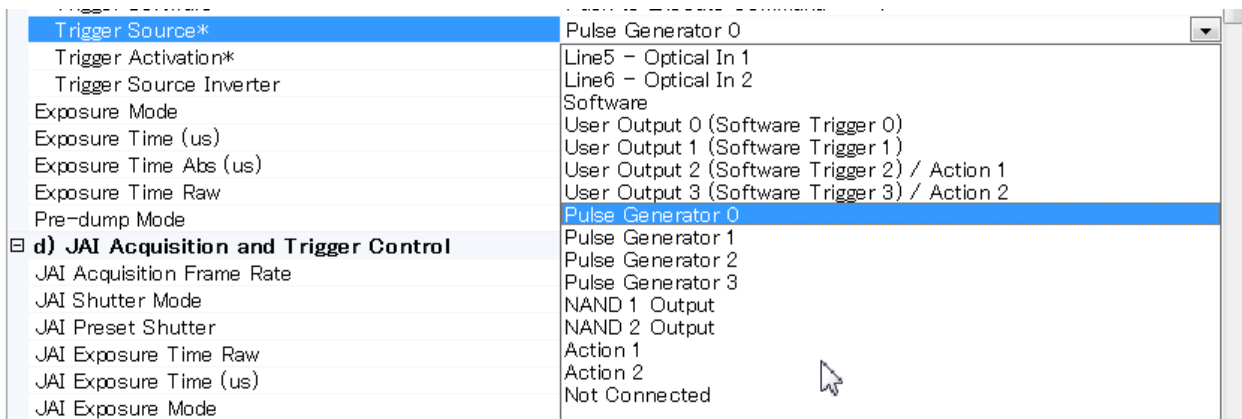

### 11.4.3 Setting the image size

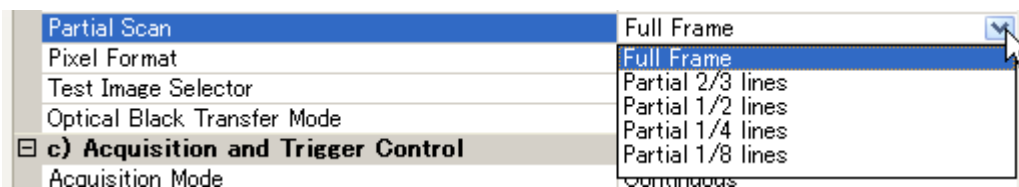

### 11.4.4 Acquisition of the image

The settings for image capturing are controlled in Acquisition and Trigger Control or JAI Acquisition and Trigger Control. The following shows the screen.

<b>c) Acquisition and Trigger Control</b>	
Acquisition Mode	Continuous
Acquisition Start	Push to Execute Command ---->
Acquisition Stop	Push to Execute Command ---->
<b>Trigger Selector*</b>	Frame Start
Trigger Mode*	Off
Trigger Software*	Push to Execute Command ---->
Trigger Source*	Not Connected
Trigger Activation*	Rising Edge
Trigger Source Inverter	False
Exposure Mode	Timed
Exposure Time (us)	40032.00000
Exposure Time Abs (us)	40032.00000
Exposure Time Raw	1251
Pre-dump Mode	Off
<b>d) JAI Acquisition and Trigger Control</b>	
JAI Acquisition Frame Rate	25 fps
JAI Shutter Mode	Preset Shutter
JAI Preset Shutter	Shutter off
JAI Exposure Time Raw	1251
JAI Exposure Time (us)	40032
JAI Exposure Mode	Continuous trigger

After the setting of capture is completed, push StartAcquisition button. As for the details of each operation mode, refer to 10. Operation Modes.

#### 11.4.5 How to look at XML file

All features and registers of the camera are stored in the camera as an XML file. This XML file is stored in the following folder.

My computer → Local disk ( C ) → Program files → GenICam\_V2.0 → xml → TransportLayers → JAI

#### 11.4.6 Feature Tree Information

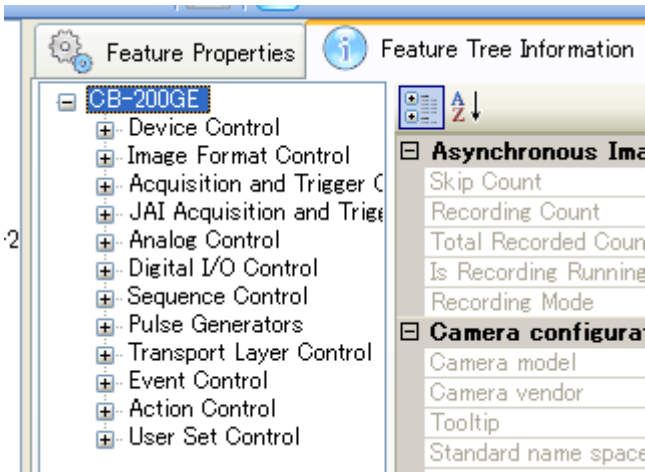

11.4.7 Feature Properties (Guru)

Feature Properties | Feature Tree Information | Processing

Guru | Node Info | Refresh | Wizard | Script

**a) Device Control**

Device Vendor Name	JAI Ltd., Japan
Device Model Name	CB-200GE
Device Version	1.2.4.0
FPGA Version	132
Device Manufacturer Info	See the possibilities
Device ID	U200539
Device User ID	
Device Scan Type	Areascan
Device Max Throughput	50181600
Device Reset	Push to Execute Command ---->

**b) Image Format Control**

Sensor Width	1624
Sensor Height	1236
Sensor Taps	One
Sensor Digitization Taps	One
Width Max	1624
Height Max	1236
Width	1624
Height	1236
Offset X	0
Offset Y	0
Line Pitch	1624
Partial Scan	Full Frame
Pixel Format	8 Bit BAYRG
Test Image Selector	Off
Optical Black Transfer Mode	Off

**c) Acquisition and Trigger Control**

Acquisition Mode	Continuous
Acquisition Start	Push to Execute Command ---->
Acquisition Stop	Push to Execute Command ---->
Trigger Selector*	Frame Start
Trigger Mode*	Off
Trigger Software*	Push to Execute Command ---->
Trigger Source*	Not Connected
Trigger Activation*	Rising Edge
Trigger Source Inverter	False
Exposure Mode	Timed
Exposure Time (us)	40032.00000
Exposure Time Abs (us)	40032.00000
Exposure Time Raw	1251
Pre-dump Mode	Off

**d) JAI Acquisition and Trigger Control**

JAI Acquisition Frame Rate	25 fps
JAI Shutter Mode	Preset Shutter
JAI Preset Shutter	Shutter off
JAI Exposure Time Raw	1251
JAI Exposure Time (us)	40032
JAI Exposure Mode	Continuous trigger

**e) Analog Control**

Gain Selector	Analog All
Gain (Raw)	0
Black Level (Raw)	538
Digital Noise Filter	Off

<b>f) Digital I/O Control</b>	
Line Selector	Line3 - Optical Out 1
Line Source	Off
Line Inverter	False
Line Status	False
Line Mode	Output
Line Format	Opto-Coupled
Line Status All	0
User Output Selector	User Output 0
User Output Value	False
Software Trigger 0	0
Software Trigger 1	0
Software Trigger 2	0
Software Trigger 3	0
<b>g) Sequence Control</b>	
Sequence Mode	Off
Sequence Repetition Count	0
Last Sequence	10
Sequence Selector	Sequence 1
Sequence Exposure Time Raw	1251
Sequence Master Gain Raw	0
Sequence ROI Size X	1624
Sequence ROI Size Y	1236
Sequence ROI Offset X	0
Sequence ROI Offset Y	0
Save Sequence Settings	Push to Execute Command ---->
Reset Sequence Settings	Push to Execute Command ---->

<b>h) Pulse Generators</b>	
Clock Source	25 MHz
Clock Pre-scaler	1
Pulse Generator Clock (MHz)	25.00000
Pulse Generator Selector	Pulse Generator 0
Pulse Generator Length	1
Pulse Generator Length (ms)	0.00004
Pulse Generator Frequency (Hz)	25000000.00000
Pulse Generator Start Point	0
Pulse Generator Start Point (ms)	0.00000
Pulse Generator End Point	1
Pulse Generator End Point (ms)	0.00004
Pulse Generator pulse-width (ms)	4E-05
Pulse Generator Repeat Count	0
Pulse Generator Clear Activation	Free Run
Pulse Generator Clear Source	Off
Pulse Generator Clear Inverter	False
<b>i) Transport Layer Control</b>	
Payload Size	2007264
GigE Vision Major Version	1
GigE Vision Minor Version	1
Is Big Endian	True
Character Set	UTF8

## CM-030GE/CM-030GE-RA / CB-030GE/CB-030GE-RA

[-] Interface Selector	0
MAC Address	00-0C-DF-02-71-04
Supported LLA	True
Supported DHCP	True
Supported Persistent IP	True
Current IP Configuration LLA	True
Current IP Configuration DHCP	True
Current IP Configuration Persistent IP	False
Current IP Address	169.254.1.117
Current Subnet Mask	255.255.0.0
Current Default Gateway	0.0.0.0
Persistent IP Address	192.168.1.4
Persistent Subnet Mask	255.255.255.0
Persistent Default Gateway	0.0.0.0
[-] GigE Vision Supported Option Selector	Link Local Address configuration
Supported Option	True
First URL	Local:JAI_CB-200GE_Ver204.zip;21 BC0000;6FB9
Second URL	
Number Of Interfaces	1
Message Channel Count	1
Stream Channel Count	1
Supported Optional Commands EVENT DA	False
Supported Optional Commands EVENT	True
Supported Optional Commands PACKET F	True
Supported Optional Commands WRITEMEM	True
Supported Optional Commands Concatena	True

Heartbeat Timeout	15000
Timestamp Tick Frequency	62500000
Timestamp Control Latch	Push to Execute Command ---->
Timestamp Control Reset	Push to Execute Command ---->
Timestamp Tick Value	0
Control Channel Privilege	Control Access
Message Channel Port	65364
Message Channel Destination Address	169.254.228.213
Message Channel Transmission Timeout (s)	300
Message Channel Retry Count	2
Message Channel Source Port	65364
[-] Stream Channel Selector	0
Stream Channel Port	56090
Do Not Fragment	True
Packet Size	1428
Packet Delay*	836
Stream Channel Destination Address	169.254.228.213
Stream Channel Source Port	56090
Event GEV_EVENT_TRIGGER Enabled	False
Event GEV_EVENT_START_OF_EXPOSURE	False
Event GEV_EVENT_END_OF_EXPOSURE	False
Event GEV_EVENT_START_OF_TRANSFER	False
Event GEV_EVENT_END_OF_TRANSFER	False

[-] Inter-Packet Delay Calculator	
Packet Size	1428
Pixel Format	8 Bit BAYRG
Expected Bandwidth Usage (%)	90.00000
Maximum Acquisition Frame-rate (fps)	25.00000
Inter-Packet Delay Estimate	836
Packet Delay*	836
[-] Intermediate Values	
Number of Packets	1445
Total Image Size (Payload + GVSP ov	2085342
Total Image Transmission Time per s	0.4170684
Total Pause Time (s)	0.4829316
Inter-Packet Delay Time (s)	1.3368348788927336E-05

<b>j) Event Control</b>	
Event Selector	Acquisition Trigger
Event Notification	Off
<b>Acquisition Trigger Event Data</b>	
Event ID	
Timestamp	
<b>Acquisition Start Event Data</b>	
<b>Acquisition End Event Data</b>	
<b>Exposure Start Event Data</b>	
<b>Exposure End Event Data</b>	
<b>Optical Output 1 Rising Edge Event Data</b>	
<b>Optical Output 1 Falling Edge Event Data</b>	
<b>Optical Output 2 Rising Edge Event Data</b>	
<b>Optical Output 2 Falling Edge Event Data</b>	
<b>Optical Input 1 Rising Edge Event Data</b>	
<b>Optical Input 1 Falling Edge Event Data</b>	
<b>Optical Input 2 Rising Edge Event Data</b>	
<b>Optical Input 2 Falling Edge Event Data</b>	
<b>k) Action Control</b>	
Device Key	0x00
Action Selector	1
Group Key	0x00
Group Mask	0x00
<b>l) User Set Control</b>	
UserSet Selector	Factory
UserSet Load	Push to Execute Command ---->
UserSet Save	Push to Execute Command ---->
Current UserSet Selector	Factory

## 12. External Appearance and Dimensions

### 12.1. CM-030GE and CB-030GE

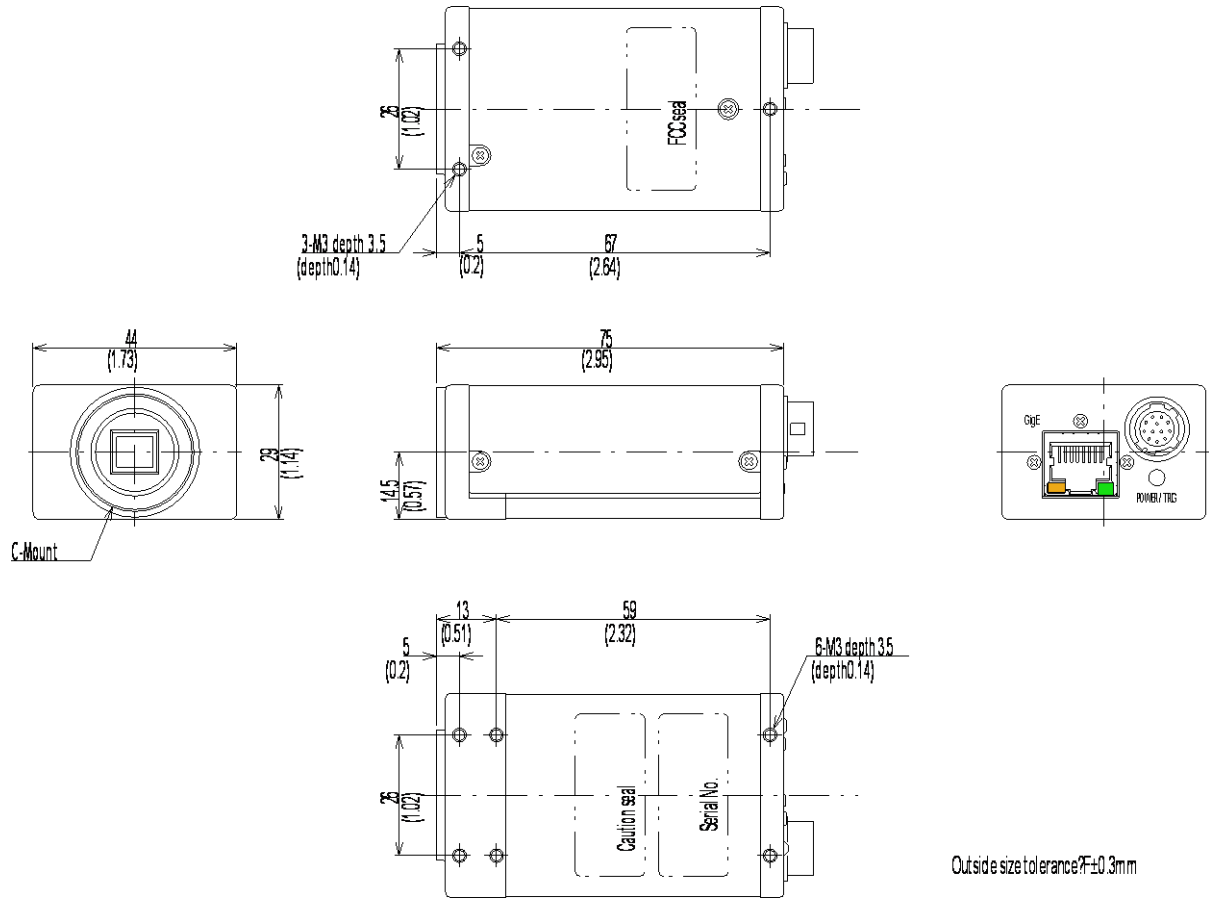

Fig. 33. CM-030GE/CB-030GE Outline

12.2. CM-030GE-RA and CB-030GE-RA

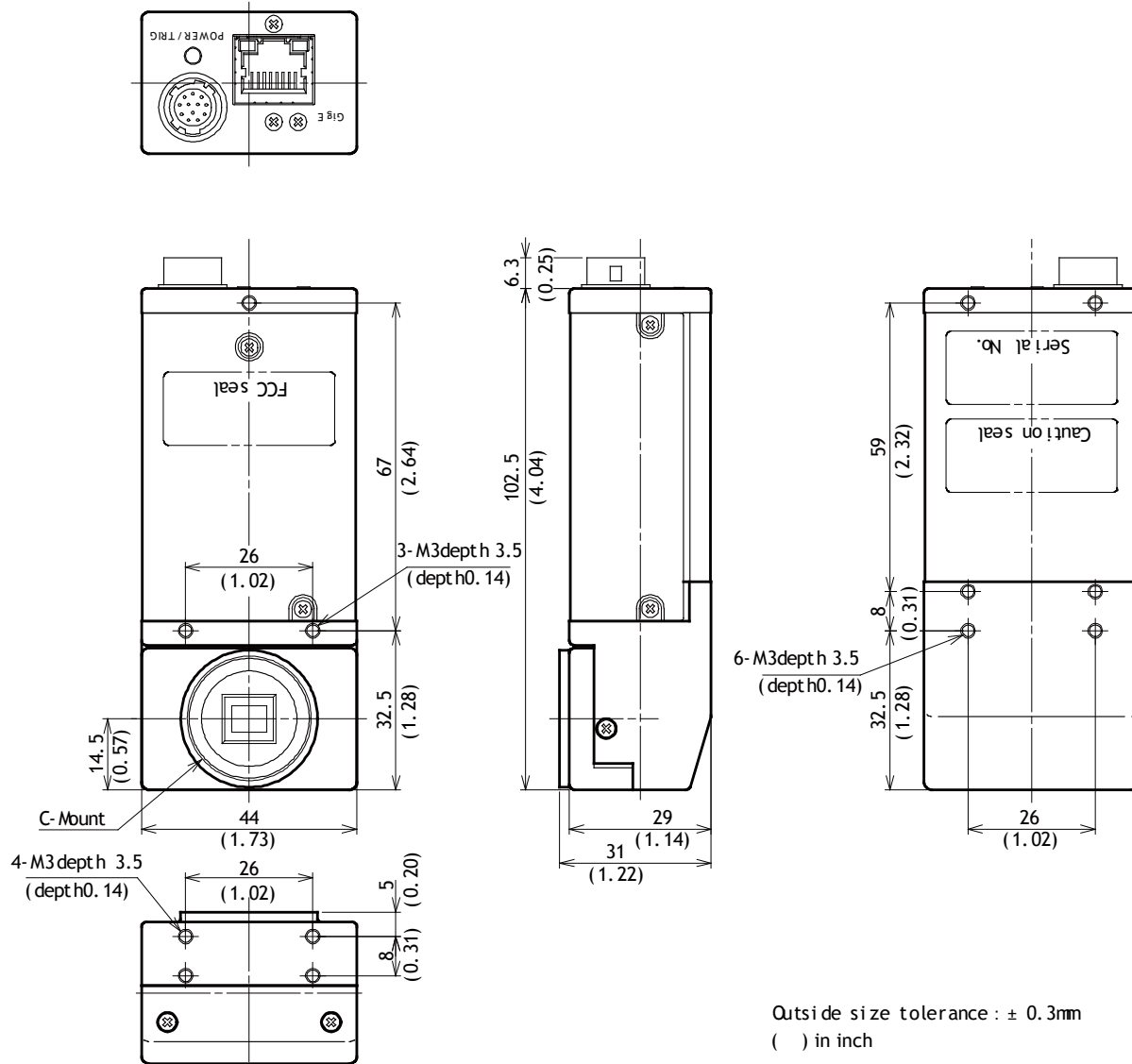

Fig.34. CM-030GE-RA/CB-030GE-RA Outline



### 13. Specifications

#### 13.1. Spectral response

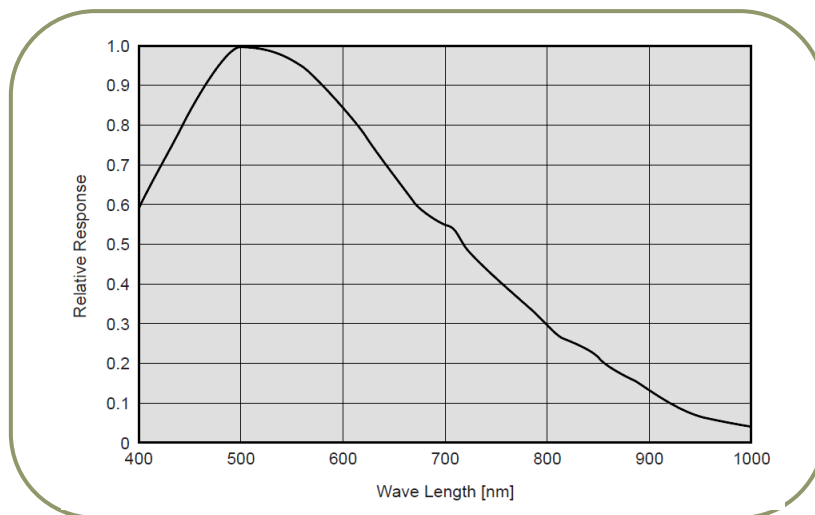

Fig. 35. Spectral response for CM-030GE/CM-030GE-RA

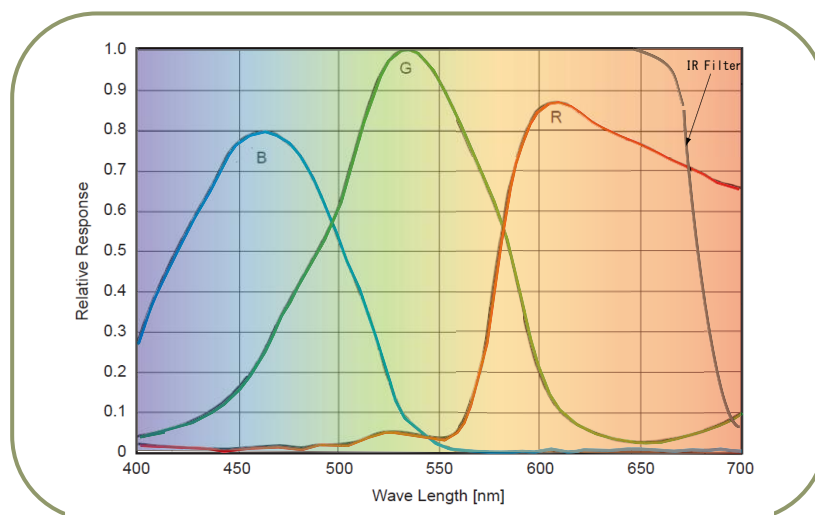

Fig.36. Spectral response for CB-030GE/CB-030GE-RA

### 13.2. Specification table

Specifications	CM-030GE/CM-030GE-RA	CB-030GE/CB-030GE-RA
Scanning system	Progressive scan	
Frame rate full frame	90.5 frames/sec. Progressive (511 lines/frame)	
Pixel clock	40 MHz	
Line frequency	46.296 kHz ( 1H = 21.6 $\mu$ s ), (864 pixel clock/line)	
CCD sensor	1/3". Monochrome ICX424AL	1/3" Bayer Color ICX424AQ
Sensing area	4.85 (h) x 3.66 (v) mm 1/3 inch diagonal	
Cell size	7.4 (h) x 7.4 (v) $\mu$ m	
Active pixels	656 (h) x 494 (v)	
Pixels in video output.		
Full Scan	656 (h) x 494 (v) 90.5 fps. H = 46.296 kHz	
2/3 partial Scan	656(h) x 326 (v) 128 fps H= 46.296kHz	
1/2 partial Scan	656 (h) x 246 (v) 159 fps. H = 46.296 kHz	
1/4 partial Scan	656 (h) x 122 (v) 255 fps. H = 46.296kHz	
1/8 partial Scan	656 (h) x 62 (v) 361 fps. H = 46.2965 kHz	
Vertical Binning	656 (h) x 247 (v) 166.2 fps. H = 42.735 kHz ( *Note)	
Region-of-interest (ROI)	User Definable. Memory read-out	
Sensitivity on sensor (minimum)	0.05 Lux (Max. gain, Shutter OFF, 50% video )	0.4 Lux (Max. gain, Shutter OFF, 50% Green, w/IR cut filter)
S/N ratio	More than 50 dB (0dB gain)	
Digital Video output.	GigE Vision Compliant Mono8, Mono10, Mono10_Packed	GigE Vision Compliant BAYRG8, BAYGB8, BAYRG10, BAYGB10
Iris video output. Analogue	0.7 V p-p , enabled by internal switch	
Gain	Manual -3 to +24 dB (1 step=0.0358dB)	
Synchronization	Internal X-tal	
GPIO Module	Configurable 14-in / 9-out switch 12-bit counter based on 25MHz clock or Pixel clock 20-bit counter programmable for length, start point, stop point, repeat	
Hardware Trigger modes	Edge Pre-Select , Pulse Width Control, RCT, Frame Delay and Sequence	
OB area transfer mode	ON / OFF	
Event message	SYNC / ASYNC mode ( Trigger mode status when exposure starts ) Exposure start, Exposure end, Trigger IN, Video start, Video end	
Electronic Shutter	OFF(1/90) and 1/100 to 1/10,000 in 9 steps 2L(43.2 $\mu$ s) to 511L ( 11.037ms) in 1L steps $\mu$ sec - user definable. Same range as PE max. 2 sec ( Can be set by 100 $\mu$ s unit or Pixel Clock unit)	
Control interface	Register based. GigE Vision / GenIcam compliant	
Functions controlled via GigE Vision Interface	Shutter, Gain, Black Level, Trigger mode, Read out mode, GPIO setup ,ROI ( GenIcam mandatory functions )	
GigE Vision Streaming Control	Packet size, Delayed ( Frame ) read-out, inter-packet delay Jumbo frame can be set at max. 4K(4040) , Default packet size is 1428 Byte.	
Indicators on rear panel	Power, Hardware trigger, GigE Link, GigE activity	
Operating temperature	-5°C to +45°C	
Humidity	20 - 90% non-condensing	
Storage temp/humidity	-25°C to +60°C/20% to 90% non-condensing	
Vibration	10G (20Hz to 200Hz, XYZ)	
Shock	70G	
Regulatory	CE (EN61000-6-2 and EN61000-6-3), FCC part 15 class B, RoHS, WEEE	

## CM-030GE/CM-030GE-RA / CB-030GE/CB-030GE-RA

Specifications	CM-030GE/CM-030GE-RA	CB-030GE/CB-030GE-RA
Power	12V DC $\pm$ 10%. 3.6 w	
Lens mount	C-mount, Rear protrusion on C-mount lens must be less than 10.0mm	
Flange back	17.526mm Tolerance 0 to -0.05mm	
IR-cut & Optical Low Pass Filter	Built in (only for CB-030GE/CB-030GE-RA)	
Dimensions	CM/CB-030GE	44 x 29 x 75 mm (W x H x D) excluding protuberances
	CM/CB-030GE-RA	44 x 29 x 102.5 mm (W x H x D) excluding protrusions
Weight	CM/CB-030GE	125 g
	CM/CB-030GE-RA	155 g

*For stable operation within the above specifications, allow approximately 30 minutes warm up.*

*Note: Above specifications are subject to change without notice*

## 14. Appendix

### 14.1. Precautions

Personnel not trained in dealing with similar electronic devices should not service this camera. The camera contains components sensitive to electrostatic discharge. The handling of these devices should follow the requirements of electrostatic sensitive components.

Do not attempt to disassemble this camera.

Do not expose this camera to rain or moisture.

Do not face this camera towards the sun, extreme bright light or light reflecting objects, including laser sources.

When this camera is not in use, put the supplied lens cap on the lens mount.

Handle this camera with the maximum care.

Operate this camera only from the type of power source indicated on the camera.

Remove power from the camera during any modification work, such as changes of jumper and switch settings.

### 14.2. Typical Sensor Characteristics

The following effects may be observed on the video monitor screen. They do not indicate any fault of the camera, but do associate with typical sensor characteristics.

#### V. Aliasing

When the camera captures stripes, straight lines or similar sharp patterns, jagged image on the monitor may appear.

#### Blemishes

All cameras are shipped without visible image sensor blemishes.

Over time some pixel defects can occur. This does not have a practical effect on the operation of the camera. These will show up as white spots (blemishes).

Exposure to cosmic rays can cause blemishes to appear on the image sensor. Please take care to avoid exposure to cosmic rays during transportation and storage. It is recommended using sea shipment instead of air flight in order to limit the influence of cosmic rays to camera.

Pixel defects/blemishes also may emerge due to prolonged operation at elevated ambient temperature, due to high gain setting or during long time exposure. It is therefore recommended to operate the camera within its specifications.

#### Patterned Noise

When the sensor captures a dark object at high temperature or is used for long time integration, fixed pattern noise may appear in the image.

### 14.3. Caution when mounting a lens on the camera

When mounting a lens on the camera dusts particles in the air may settle on the surface of the lens or the image sensor of the camera. It is therefore important to keep the protective caps on the lens and on the camera until the lens is mounted. Point the lens mount of the camera downward to prevent dust particles from landing on the optical surfaces of the camera. This work should be done in a dust free environment. Do not touch any of the optical surfaces of the camera or the lens.

#### **14.4. Caution when mounting the camera**

When you mount the camera on your system, please make sure to use screws of the recommended length described in the following drawing. Longer screws may cause serious damage to the PCB inside the camera.

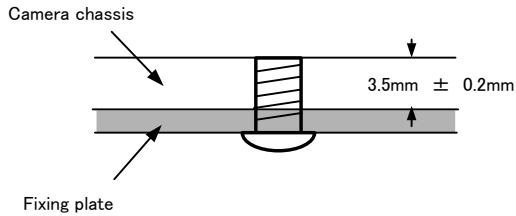

If you mount the tripod mounting plate, please use the provided screws.

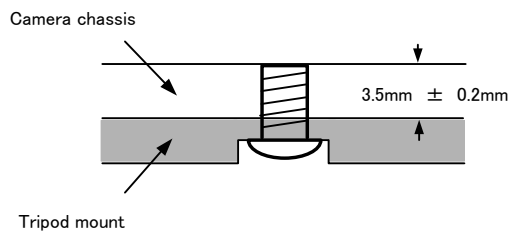

#### **14.5. Exportation**

When exporting this product, please follow the export regulation of your own country.

#### **14.6. References**

1. This manual for CM-030GE/CM-030GE-RA / CB-030GE/CB-030GE-RA can be downloaded from [www.jai.com](http://www.jai.com)
2. Datasheet for CM-030GE/CM-030GE-RA / CB-030GE/CB-030GE-RA can be downloaded from [www.jai.com](http://www.jai.com)
3. Camera control software can be downloaded from [www.jai.com](http://www.jai.com)



## User's Record

Camera type: CM-030GE/CM-030GE-RA /  
CB-030GE/CB-030GE-RA

Revision: .....

Serial No. ....

Firmware version. ....

*For camera revision history, please contact your local JAI distributor.*

---

## User's Mode Settings.

## User's Modifications.

---

Company and product names mentioned in this manual are trademarks or registered trademarks of their respective owners. JAI A-S cannot be held responsible for any technical or typographical errors and reserves the right to make changes to products and documentation without prior notification.

---

### **Europe, Middle East & Africa**

Phone +45 4457 8888

Fax +45 4491 3252

### **Asia Pacific**

Phone +81 45 440 0154

Fax +81 45 440 0166

### **Americas**

Phone (toll-free) +1 800 445 5444

Phone +1 408 383 0300

**Visit our web site at [www.jai.com](http://www.jai.com)**



*See the possibilities*