

Hybrid Seating User Manual



Hybrid Seating User Manual

	Page
Introduction	4
Pre-use Checks	4
Fitting the Hybrid Seat into the Host Wheelchair (including Multi Adjustable interface instructions)	4
Back Support Cushions	6
Adjusting the Head Support	6
Adjusting the Foot Support	7
Cleaning Instructions	7
Maintenance by Carer	8
Maintenance by Seating Specialist	8
Moulded Trays - User Instructions	9
Posture Belt & Posture Harness - User Instructions	10
Moulded Sandals and Footstraps - User Instructions	11
AEL Mounting Kit - User Instructions	12
Transportation	13
Important Reminders	14
Further Information	14
Notes & Manufacturer's Label	15

Introduction

The Hybrid Seat is a custom-made device and it should only be used by the person it was made for.

This user manual gives important safety information, advice about making basic adjustments to the Hybrid Seat and user care instructions. The manual also gives important information about maintenance and adjustments that must be carried out by Blatchford Clinical Services or the Wheelchair Service.

Pre-use Checks

Important Safety Information

Before using your Hybrid Seat please check the following:

- The retaining strap on the base cushion (where fitted) must be securely fastened (see 'Fitting the Hybrid Seat into Host Wheelchair') on the next page.
- The backrest must be fitted to the wheelchair correctly (make sure the brackets are located into the mounting blocks on the wheelchair properly and are secured with the locking levers).
- **Never use the back rest or V-Trak mechanism to manoeuvre the wheelchair (whether or not the wheelchair is occupied). This could damage the backrest and/or injure the occupant.**
- All user support items (such as postural straps and harnesses) should be securely fastened.

If you are not sure about how to do any of these things please contact your Wheelchair Service.

Fitting the Hybrid Seat Insert into the Host Wheelchair

BAIS - Blatchford Adaptive Interface System

Components:

- A Interface
- B Latch Clamps
- C Seating Attachment



Fitting the Interface to the Wheelchair (Applies to folding wheelchairs only)



1. Ensure that the wheelchair is fully open.
2. Check that the latches are in the open position (**fig.1**).
3. Position the interface hooks, ensuring that on each side one hook is behind and one hook is in front of the clamps (**fig.2** and **fig.3**).
4. Slide the latch clamps so that the tongue is over the top of hooks (**fig.4**).
5. Check that the interface is correctly located by attempting to lift it out (a small amount of movement is normal).
6. To remove the interface, slide the latches back and lift the interface upward.

Attaching the Seating System to the Interface

1. Taking care when lifting, position the seat onto the interface and locate the front hook onto the front bar (**fig.5**).
2. Allow the seat to tilt backwards and down, pressing it firmly into place. A click will be heard as the locks engage.
3. Check that the pins have fully located by pulling the seat forward, (a small amount of movement is normal). However, the seat should not lift forward.
4. Repeat stages 1 to 3 if the seat lifts from the interface.

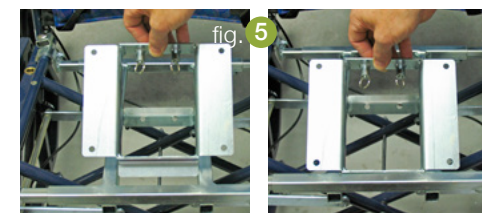

Removing the Seating System from the Interface

1. Undo or disconnect and backrest fixings.
2. Pull "D" ring (**fig.6, located under the front of the seat**) firmly and lean the Seating System forward.
3. Taking care, lift the Seating System upward and clear from the wheelchair.



Base Cushion Velcro Fixing

This type of base cushion sits on top of the wheelchair seat canvas.

- Place the cushion onto the wheelchair seat canvas making sure that it is facing the right way.
- Using the velcro fastener to secure the cushion.

If you are not sure about how to do any of these things please contact your Wheelchair Service.

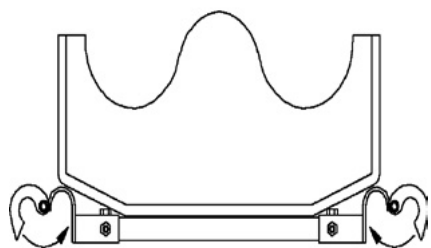

fig. 7

Base Cushions in a Polypropylene Shell

This type of base cushion sits on top of the wheelchair seat canvas.

- Remove armrests from the wheelchair to improve access if necessary.
- Place the base cushion onto the wheelchair seat canvas.
- Pass the retaining strap (this comes from each side of the base cushion's plastic shell) around the wheelchair upright posts and fasten the ends of the buckle together (see fig.8).
- Tighten the retaining strap by pulling the loose end of the webbing away from the buckle.
- Refit the wheelchair armrests.
- Reverse the process for the removal of the Hybrid Seat Cushion.

Base Cushion Velcro Fixing

This type of base cushion sits on top of the wheelchair seat canvas.

- Place the cushion onto the wheelchair seat canvas making sure that it is facing the right way.
- Using the velcro fastener to secure the cushion.

If you are not sure about how to do any of these things please contact your Wheelchair Service.

Back Support Cushions

Back supports are usually fixed to the host wheelchair using the 'V-Trak' mounting system.

This system has been designed to allow the backrest to be set in the best position for the wheelchair user. The 'V Trak' system and any adjustments to it must only be carried out by a seating specialist from either the Wheelchair Service or Blatchford Clinical Services.

To remove the back support from the wheelchair: (this is shown here at fig.9)

- Raise the Locking Lever at the end of each V-Trak Arm so that it is fully vertical (this is the unlocked position on the diagram).

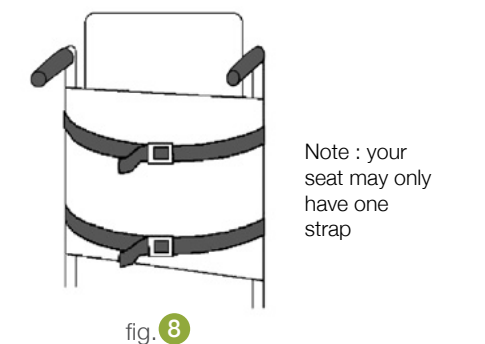

fig. 8

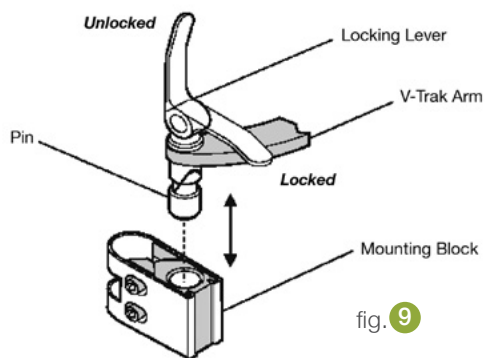

fig. 9

- With a hand under the outer end of each V-Trak arm, lift the system evenly upwards and clear of the Mounting Blocks.
- Fully remove the system from the wheelchair back support posts.

To fit the back support to the wheelchair:

- Make sure both Locking Levers are fully upright (the Unlocked position).
- With a hand under the outer end of each V-Trak arm, lower the system evenly into the Mounting Blocks on the wheelchair.
- When the Pins are located in the holes in the Mounting Blocks, push down firmly.
- Make sure that the Pins are fully in place before pushing the Locking Levers downwards into the Locked position. Make sure the levers are pushed all the way down.
- The system is now fully attached to the wheelchair.
- Check that the back support is secure before sitting the user in the wheelchair.
- Some of our Hybrid wheelchairs have Matrix or Lynx backs. The Matrix and Lynx mechanisms should only be altered by a Blatchford special seating engineer or trained engineer from the wheelchair service.

Adjusting the Head Support

The headrest can be moved both up and down and front to back. The angle of the support can also be set to get the best position (see fig.10).

- To adjust the height of the head support, turn the locking knob (A) anticlockwise. Alter the height of the headrest to suit the user and re-tighten the knob.
- To adjust the head support in or out turn the locking knob (B) anticlockwise. Alter the position of the headrest to suit the user and re-tighten the knob.

To adjust the angle of the headrest (C) please consult your Wheelchair Service.

The head support must be in place during the transportation of the user in the Hybrid seat.

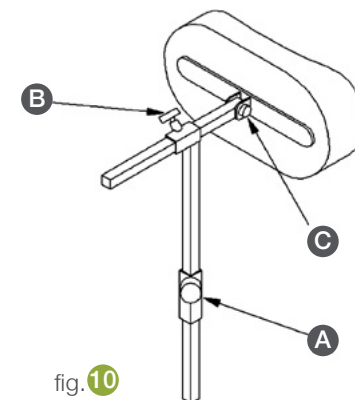

fig. 10

Adjusting the Foot Support (fig.11) (if fitted)

To adjust the height of the footrest:

- Undo the locking knob(s) at the back of the footrest (A)
- Move the footrest to the correct height and re-tighten the locking knob(s).

To remove the footrest for storage:

- Loosen the locking knob (B) and pull the footrest away from the seat.
- Reverse the process to re-attach.

Make sure that the locking knobs are properly tightened.

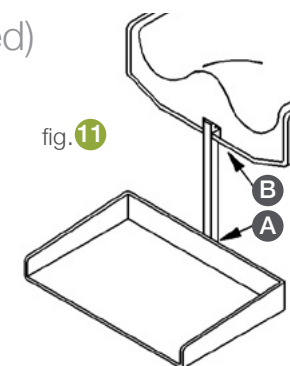

fig. 11

Cleaning Instructions

Plastic Shell

A damp cloth can be used to remove dirt from the plastic outer shell of the Hybrid Seat.

Cushions

Cushions are usually sealed inside a clear plastic, waterproof liner. The liner can be cleaned by wiping it with a damp soapy cloth. Allow to dry before re-use.

The cushion should be left sealed within the liner.

Terry Towelling Seat and Head Support Covers

These covers can be taken off for washing:

- Loosen the ties or toggles that run around the edges of the covers.
- Pull the edges of the cover over the edges of the seat.
- Pull the cover away from the seat carefully (make sure it is not caught on the seat or wheelchair frame).
- The cover can now be hand or machine washed (no more than 30°C).
- Do not tumble dry or use bleach (bleach will damage the material and tumble drying may cause it to shrink).

Reverse the process to refit the covers. **Make sure that:**

- The covers are completely dry.
- The cover is fitted evenly to the seat to prevent any creases as these could cause localised skin marking and discomfort.
- Ties and toggles are secure and free from moving parts.

Maintenance by Carer

The following checks should be carried out by the carer on a regular basis to make sure that the Hybrid Seat is both safe and comfortable:

- Check there is no damage to the retaining straps and that the buckles are working properly.
- Check there is no damage to any postural straps and harnesses and that the buckles on these are working properly.
- Check that all adjustable parts of the seat operated by the carer, as previously described, adjust freely and are not damaged.
- Check there is no damage to the foam lining resulting in raised or sharp surfaces.

If the user should suffer any form of marking on the skin or appears to be in discomfort this should be reported to the Wheelchair Service immediately.

Maintenance by Seating Specialist

The following checks are important and must only be carried out by the Wheelchair Service or by Blatchford Clinical Services.

In order to ensure continuing safety of the Hybrid Seat, it is recommended that the interval between these checks is no longer than 12 months.

- Check that the user's shape is still accommodated by the shape of the Hybrid Seat.
- Check that the Hybrid Seat is not too tight for the user as a result of growth or weight gain.
- Check there is no structural damage to the plastic shells or any of the brackets and that all securing bolts are still in place.
- Check the quality of the foam, particularly underneath the buttocks.
- Check that all locking knobs on the brackets are in place and functioning correctly.
- Check that all straps are undamaged and buckles are functioning correctly.

Moulded Trays - User Instructions

Moulded Trays are designed to provide a work or play surface together with support and control in conjunction with any seating arrangement.

Using the tray

1. Ensure that the two vertical stems on the underside of the tray are securely located in the wheelchair location points.
2. To fine tune the position of the tray in relation to the user, the locking knobs on the underside of the tray must be loosened to allow the tray to be moved forwards or backwards into the desired position. Re-tighten the locking knobs after adjustment.

Width adjustment

To change the width of the tray fittings to suit an alternative wheelchair;

1. Turn the tray over and loosen the four screws using a large flat bladed screw driver (do not remove the screws completely).
2. Slide the adjustment tubes out/in to the desired width, ensuring that they remain parallel.
3. Re-tighten the screws.

Cleaning

A damp, soapy cloth can be used to clean the tray surface.

Warnings

- **ON NO ACCOUNT SHOULD ANY HOLES BE DRILLED INTO THE TRAY TOP.**
- **ENSURE ALL LOCKING KNOBS ARE SECURE BEFORE USE.**
- **THE TRAY MUST BE REMOVED BEFORE TRANSPORTATION.**



Posture Belt & Posture Harness - User Instructions

Using a harness:

- Do the bottom straps up first ensuring the harness is away from the user's neck.
- Do the top straps up by clicking the male buckle into the attached female buckle of the harness.
- Adjust the top straps by pulling the 'D' loop forward and down whilst holding the shoulder of the user in the desired position.



For Belts & Harnesses, always make sure that:

- Straps are not twisted.
- Buckles are adjusted so that when they are fastened together there is no slack in the strap.
- Buckles are fully locked together.
- Each end of the belt or harness is still securely attached to the seating system or wheelchair.
- Buckles or webbing do not show signs of excessive wear – if you are concerned about the condition of any items contact the Wheelchair Service.



Cleaning

These items should be wiped clean using a damp cloth using only a mild detergent.

(PLEASE DO NOT use bleach or products containing bleach).

A soft brush can be used to remove heavier soiling.

Safety Instructions

Blatchford posture belts and harnesses are designed to provide postural support and are intended to be used as part of a specialised seating system. The belt or harness should be fitted to the seat and adjusted at the time of delivery. Replacements must only be fitted by Blatchford or a Wheelchair Service representative.

Important Safety Warnings

POSTURAL HARNESSES AND BELTS ARE NOT DESIGNED TO BE USED AS SAFETY DEVICES AND MUST NOT BE USED AS VEHICLE RESTRAINTS FOR USE IN TRANSPORTATION.

A suitable, separate, 3-point passenger seat belt (fastened into the vehicle) must be used to secure the seated occupant during travel in order to provide protection in the event of an accident. The seatbelt should have both pelvic and upper body sections, with the upper section fastened into the vehicle at the upper level. This should be in accordance with Medical Device Report – *Guidelines for transporting children in special seats*.

ALWAYS CHECK THAT THE BELT IS A SNUG FIT. CHEST BELTS SHOULD ALWAYS BE FASTENED AROUND THE OCCUPANT'S BODY AND UNDER THE ARMS. IT IS NOT INTENDED THAT THE ARMS SHOULD BE INCLUDED WITHIN THE BELT.

If the hip belt is incorrectly adjusted there is a risk of the wheelchair occupant slipping down in their seat and could result in occupant's upper body and neck coming into contact with the belt.

If you are unsure about any of these instructions or if you are worried about the adjustment of the belt contact your Wheelchair Service.

Moulded Sandals & Footstraps - User Instructions

Moulded Sandals and Footstraps are designed to provide support and control in conjunction with any seating arrangement.

Do:

- Ensure that straps are not twisted.
- Ensure that buckles are adjusted so that when they are fastened, there is no slack in the strap.



Care

Check that buckles and straps do not show signs of excessive wear or fraying - if you are concerned about the condition of any item refer to your seating technician at the clinic or through your supplier as soon as possible.

Cleaning

These items can be wiped clean using a damp, soapy cloth. A soft brush can be used to remove heavier soiling.



Warning

THIS DEVICE IS NOT DESIGNED FOR USE AS PART OF A SAFETY RESTRAINT SYSTEM FOR TRAVEL IN A VEHICLE.

AEL Mounting Kit - User Instructions

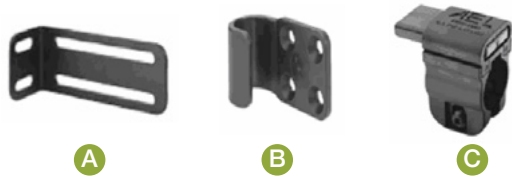

The AEL Mounting Kit is made up of the components shown above (figs. **A**, **B** and **C**). **These are not user adjustable components and therefore should not be altered in anyway by the user or carers.**

A and **B** are screwed together with the supplied fittings and attached to the back of the seating system backrest (fig.**D**) or to the bottom of the seating system seat base (fig.**H**).

Component **C** is fitted to either the backrest posts or the seat rail tubes of the wheelchair.

To attach the seat to the wheelchair, it is necessary to press (firmly) the hook part onto the tube as shown in fig. **E** and **F** next to the locating latches (fig **C**).

Once correctly located, the latch can then be moved over the hook to prevent it from being removed, as shown in fig.**H**. This should be completed for all locating latches.

The backrest or seat base is now securely attached to the wheelchair.

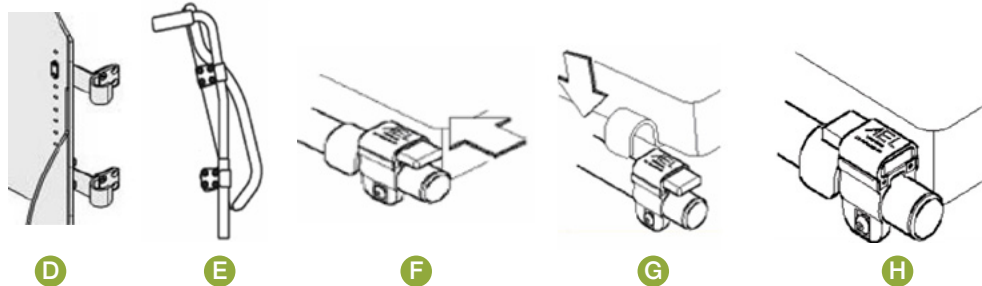

Transportation in a Motor Vehicle

NOTE: • **The Hybrid Seat must not be used as a car safety seat.**

- The Hybrid Seat is designed to allow the seat and its user to be transported in a forward facing position in a vehicle designed for the purpose (for example, in a suitably equipped minibus).

Transportation - Essential Safety Information. **NOTE:** this information should be passed on to those people making transport arrangements (e.g. schools and other organisations).

Securing the user, the Hybrid Seat and the host wheelchair in a vehicle:

1. During travel the Hybrid Seat must be securely fastened into its wheelchair as described earlier in this manual.
2. Posture belts and postural harnesses supplied as part of the seating system are designed to give postural support only. Where these items are fitted they should be used during travel **but they must not be used as the only safety restraints.**
3. **The wheelchair itself must be fastened down in the vehicle – this must be in accordance with the wheelchair manufacturer’s instructions.** (The wheelchair manufacturer should issue these instructions separately. In case of query contact the Wheelchair Service).
4. **A suitable, separate, passenger seat belt (fastened in to the vehicle) should be used by the occupant during travel. In order to achieve occupant restraint and optimum protection in a crash situation the seatbelt should have both pelvic and upper body sections (for example a 3 point type with the upper section fastened into the vehicle at the upper level) as a minimum standard.**

Using Hybrid Seat accessories during travel:

The following information and advice should be considered - the accessories used and the needs and circumstances of the user must be taken into account:

1. **The Hybrid Seat headrest should be used during travel.**
2. **Wheelchair mounted trays should always be taken off while travelling and these should be stored securely in the vehicle.**
3. **Kneeblocks used in a vehicle could cause damage to the hips and knees in the event of an accident but, without these in place, there could be risks to other passengers. (As part of the initial assessment by the Wheelchair Service the best practice for the particular user should be determined and the outcome of this assessment passed on to the people making the transport arrangements).**
4. **Footstraps are not designed to be a part of a passenger restraint system but, where these are fitted, there may be advantages in these being in place during travel. (Again these issues should be considered as part of the initial assessment by the Wheelchair Service and recommendations made to the people making the transport arrangements).**

Separate information sheets are issued with accessories and these should also be consulted.

Important Reminders

It is important that the carer is aware of and considers the following:

- The Hybrid Seat is a custom-made device to be used only by the person it was made for.
- If the user has marking on the skin or becomes uncomfortable when in the seat, contact the Wheelchair Services immediately.
- The Hybrid Seat should only be used with the wheelchair it was made for. If a different wheelchair is going to be used contact the Wheelchair Service for help and advice.
- Maintenance and adjustments (other than those shown in this User Manual) must only be carried out by Blatchford Clinical Services.
- No alterations should be made to the seat nor should other company's components be fitted without the prior agreement of Blatchford Clinical Services.
- **The Hybrid Seat is not designed for use as a car safety seat.**

Due care and attention must be taken at all times when using the Hybrid Seat

Take particular care when negotiating slopes, difficult surfaces or other obstacles.

Further Information

Information about wheelchair tie-down and occupant restraint systems can be obtained from:

C N UNWIN LTD., Unwin House, The Horseshoe, Coat Road, Martock, Somerset, TA12 6EY. Tel: 01935 827740 www.unwin-safety.com

If you have further questions about any of the following please contact the Wheelchair Service:

- availability of seating accessories.
- changing Hybrid Seat to fit a different wheelchair.
- use of the seating system in a motor vehicle.

Notes:

Manufacturer's Label:

Please attach manufacturer's label here.



QA Inspection Check List

Order Number	
--------------	--

	Technician	Inspector
Seat dimensions material used correct to order		
Interface supplied as per order		
Additional items supplied as per order		
Upholstery		
Covering as requested		
Harnessing supplied as per order		
Final assembly as per order		
Harnessing, straps correctly fitted		
Seat cleaned and labelled		
Paperwork enclosed		
Final despatch check		
Date		

Follow Blatchford: | blatchford.co.uk
@BlatchfordGrp | 0114 263 7900
/BlatchfordGrp | seatingsales@blatchford.co.uk



Chas A Blatchford & Sons Ltd, 11 & 30 Atlas Way, Sheffield, S4 7QQ, United Kingdom.
t: +44 (0) 114 263 7900 f: +44 (0) 114 263 7901