



Tripod Portable Projection Screen  
**Elite Tripod Series**

USER'S GUIDE



# Tripod Screen Parts Identification

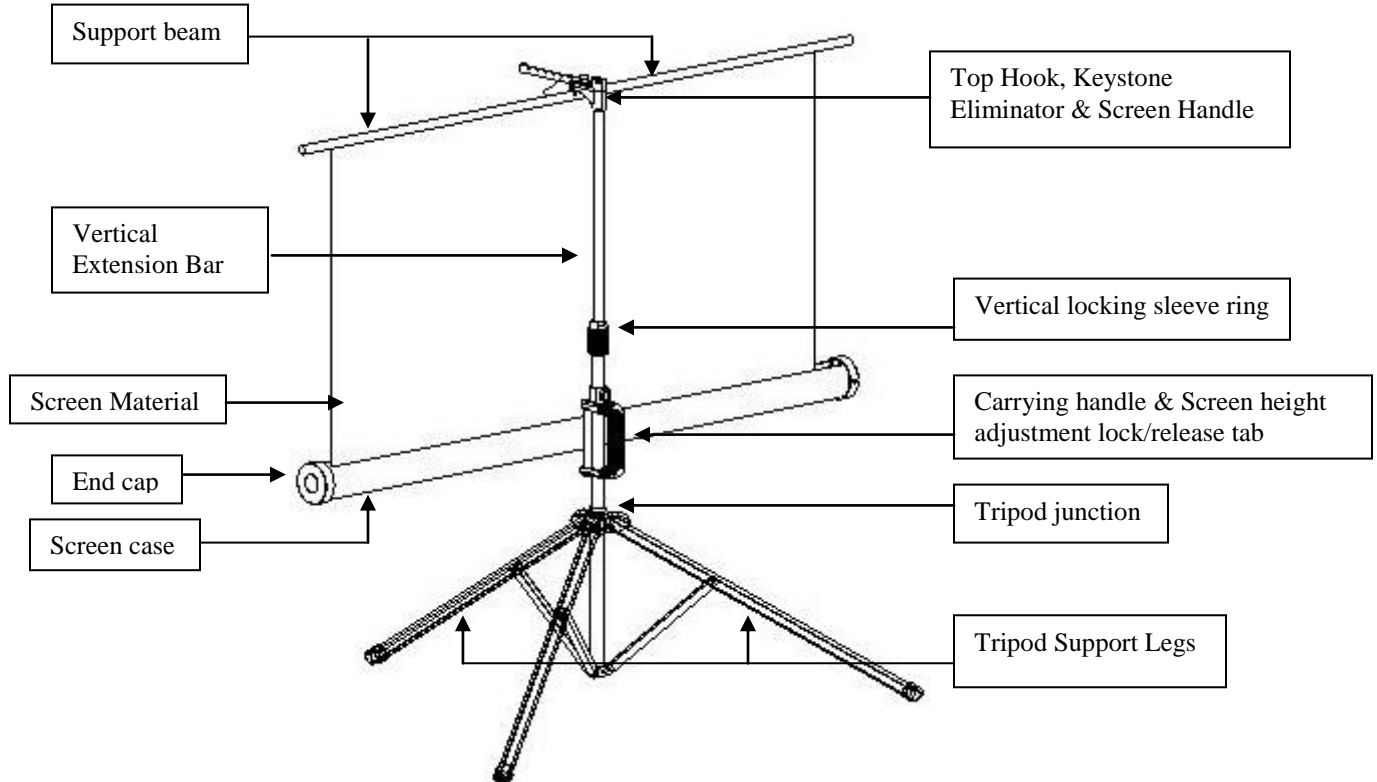

## Using the Screen

### A. Setting up the screen:

Follow the steps below and Fig. 1 & 2.

1. Place the screen in an upright position (fig.1) with the legs toward the ground.
2. Deploy the Tripod Support legs by pushing down on the Tripod Junction.
3. Turn the tripod's screen casing in a 90-degree horizontal position so that the screen casing is now parallel to the ground with the screen handle facing the bottom of the top hook.
4. Completely extend the legs as much as possible so they are stable and position them away from objects that may interfere with their balance. **DO NOT** stand the tripod on an unstable platform to avoid an injury should the tripod screen collapse.

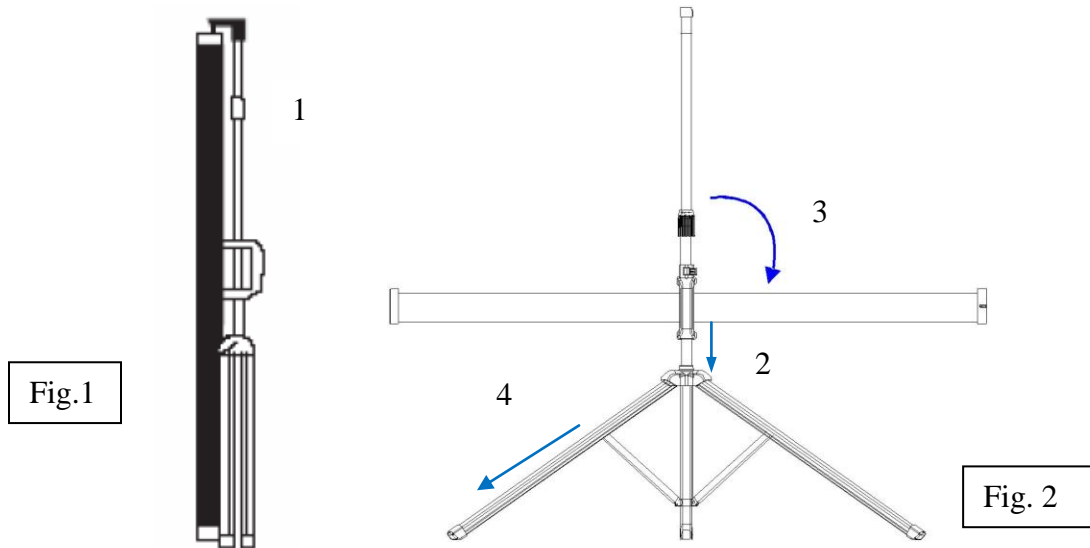

## B. Preparing the tripod screen for projection:

Follow the steps below and Fig. 3.

1. Pull the screen handle up vertically and hook the screen handle on the **Top Hook**.

*\*Note: Use the Keystone Eliminator to prevent “Keystone Effect” from occurring. Keystone Effect is caused when a projector presents its image at a downward angle causing a trapezoid-shaped image to appear on the screen. The Keystone Eliminator is designed to eliminate that effect by sloping the screen forward.*

2. Twist the **Vertical Locking Sleeve Ring counter-clockwise** to unlock the current position of the **Vertical Extension Bar** and raise it as necessary to the desired height.

3. Pull the **Screen Height Adjustment Lock/Release** tab out (to the left) located just above the **Carrying Handle** to raise or lower the bottom of the. Once the desired height has been set, push the tab in to lock the position in place.

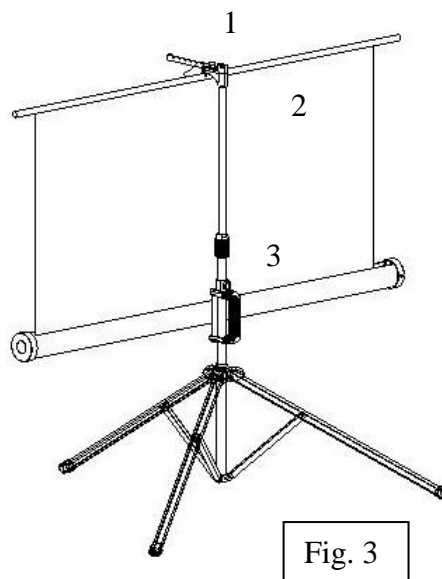

### C. Disassembling the screen:

Follow the steps below and Fig. 4.

1. Unlock the **Adjustment Handle** by pulling the locking tab to the **left** and slowly slide the handle all the way down to bring down the position of the screen's case.
2. Hold the **Extension Bar** and twist the **Vertical Locking Sleeve Ring** **counter-clockwise** to unlock and release the position of the extension bar. Once the extension bar has been brought all the way down, unhook the screen material from the **Top Hook** and slowly retract the screen back into the case.  
*\* Note: It is very important to remember to hold the extension bar first and then unlock the sleeve to prevent the extension bar from slamming and damaging the screen.*
3. Turn the screen's case **vertically clockwise** and insert the **Top Hook's** bottom pin to lock into the screen's end cap hole.
4. Close the tripod legs by pushing them in. Lastly, tighten the **Vertical Locking Sleeve Ring** by twisting it **clockwise**.

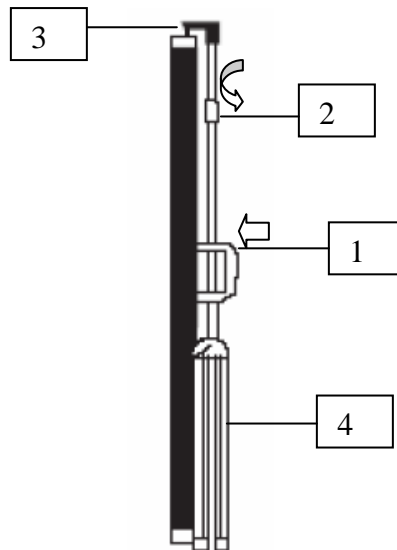

**Fig. 4**

**Note:** To ensure the screen is stable, extend the tripod's legs as much as possible.  
Do not fold the screen or allow any sharp objects to touch the screen's surface.  
Clean the screen surface often when needed.  
Careful use will extend the lifetime of this product.

# Tripod Series Dimension Table

Unit: inches										
Model	Nominal Diagonal	View Size H x W	Screen Size H x W (A)	Top of Screen at Highest Level (B1)	Top of screen at lowest level (B2)	Screen case at highest point (C1)	Screen case at lowest point (C2)	End cap size (D)	Case length closed (D2)	Case width closed (D3)
T71NWS1	71"(1:1)	50"x50"	53"x53"	111.8	71.5	35.6	16.9	2.7	58.0	5.9
T71UWS1	71"(1:1)	50"x50"	53"x53"	111.8	71.5	35.6	16.9	2.7	58.0	5.9
T85NWS1	85"(1:1)	60"x60"	63"x63"	128.7	87.8	37.5	16.9	2.7	68.0	5.9
T85UWS1	85"(1:1)	60"x60"	63"x63"	128.7	87.8	37.5	16.9	2.7	68.0	5.9
T99NWS1	99"(1:1)	70"x70"	73"x73"	147.2	97.6	35.5	16.9	2.7	78.0	5.9
T99UWS1	99"(1:1)	70"x70"	73"x73"	147.2	97.6	35.5	16.9	2.7	78.0	5.9
T113NWS1	113"(1:1)	80"x80"	83"x83"	148.4	107.5	33.4	16.9	2.7	88.0	5.9
T113UWS1	113"(1:1)	80"x80"	83"x83"	148.4	107.5	33.4	16.9	2.7	88.0	5.9
T119NWS1	119"(1:1)	84"x84"	87"x 87"	148.4	111.8	37.1	16.9	2.7	91.9	5.9
T119UWS1	119"(1:1)	84"x84"	87"x 87"	148.4	111.8	37.1	16.9	2.7	91.9	5.9
T136NWS1	136"(1:1)	96"x96"	99"x99"	148.4	123.6	40.8	16.9	2.7	104.0	5.9
T136UWS1	136"(1:1)	96"x96"	99"x99"	148.4	123.6	40.8	16.9	2.7	104.0	5.9
T84UWV1	84"(4:3)	50"x67"	55"x70"	118.1	79.9	35.4	16.9	2.7	75.0	5.9
T100UWV1	100"(4:3)	60"x80"	65"x83"	139.4	89.8	53.4	16.9	2.7	88.0	5.9
T120NWV	120"(4:3)	72"x96"	77"x99"	148.4	102.0	65.0	16.9	2.7	104.0	5.9
T120UWV1	120"(4:3)	72"x96"	77"x99"	148.4	102.0	65.0	16.9	2.7	104.0	5.9
T92UWH	92"(16:9)	45"x80"	50"x83"	124.4	74.8	68.3	16.9	2.7	88.0	5.9
T100UWH	100"(16:9)	49"x87"	54"x90"	128.3	78.7	68.3	16.9	2.7	95.2	5.9
T120UWH	120"(16:9)	59"x105"	64"x108"	138.2	89.0	62.4	16.9	2.7	112.6	5.9

\*Measurement dimensions are intended as a reference only and subject to change without notice

Note:Data Error may be ±1"

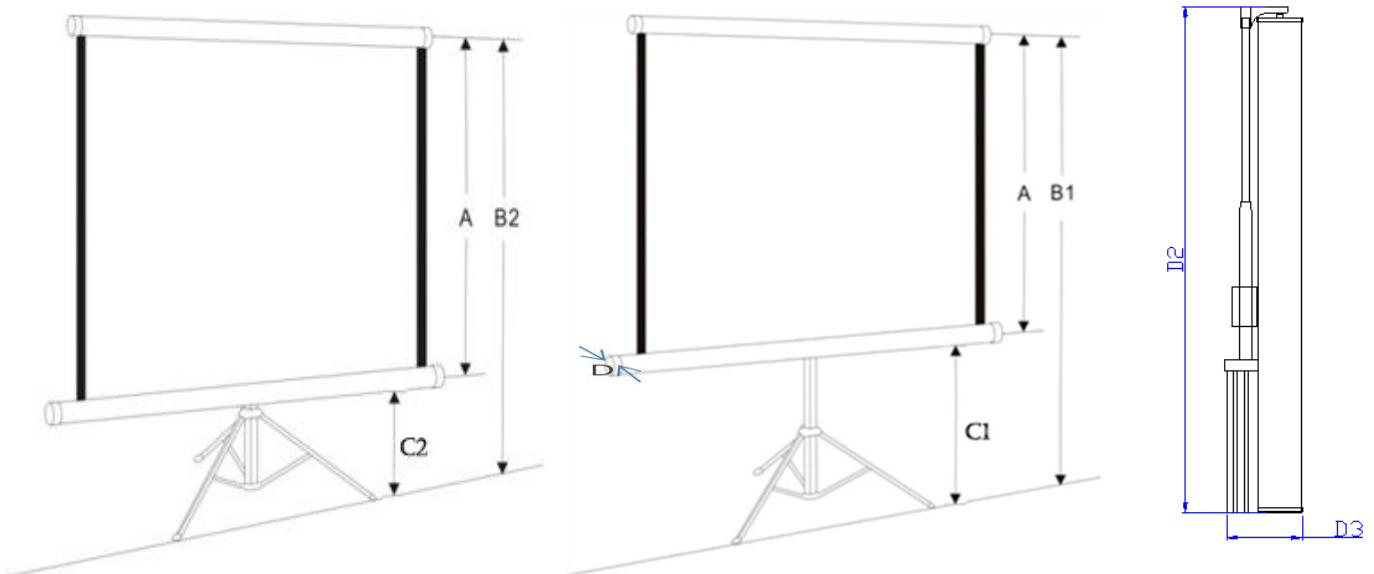

# Limited Warranty Policy

**What is Covered:** Elite Screens, Inc. ("Elite Screens") warrants its products to the first retail purchaser, if purchased new and operated in the United States or Canada, to be free from defects in workmanship and materials (except as provided below) for a period of (2) years from the date of original purchase, and (3) years for products purchased directly by educational, non-profit, religious or government organizations.

Refurbished products purchased directly from Elite Screens are warranted for a period of (90) days from the date of original purchase.

For warranty service, you must provide proof of purchase and the serial number of your product.

**How to Get Service:** Should this product prove defective during the warranty period, please visit [www.elitescreens.com/rmaform](http://www.elitescreens.com/rmaform) and submit a warranty claim form. You must provide your proof of purchase, the serial number of your product, and describe the problem you are experiencing with your screen. An Elite Screens representative will determine whether the product requires service, and provide you with further instructions on how to proceed with your warranty claim.

**Missing Parts:** If your product is missing parts, Elite Screens will, at its option, replace the part without any charge, including shipping and handling, provided that that you report your claim within (7) days of receipt. If you report your claim after (7) days of receipt, but within (30) days of receipt, Elite Screens will, at its option, replace the part without charge, but you will bear the cost of shipping and handling. If you report your claim after (30) days of receipt, you will bear all costs to replace the part.

**Returns and Exchanges:** If a return is needed, Elite Screens will issue you a Return Merchandise Authorization ("RMA") Number. This number is valid for (45) days from the date of issue, and is required to process any returns. A returned item sent to Elite Screens without a visible or valid RMA Number is subject to refusal by Elite Screens. You are responsible for the cost of returning the item and ensuring the product is properly packaged to prevent damage in transit.

Once a returned product is received, Elite Screens will, at its option, replace the product or part without charge, including ground service freight. The replacement product or part may be new or refurbished to the Elite Screens standard of quality, and is subject to stock availability. Elite Screens' liability for replacement of the covered product will not exceed the original retail selling price of the covered product. Exchange products and parts assume the remaining warranty period of the original product covered by this limited warranty.

**What is Not Covered:** This warranty is not transferable and does not cover product purchased by another end user. This warranty does not cover incidental damages, such as loss of time, loss of use, or installation costs of defective, repaired or replaced product. This warranty does not cover product that has been damaged or rendered defective as a result of (a) neglect, abuse or misuse; (b) modification of the original product; (c) improper use or installation of products not manufactured by Elite Screens; (d) service provided by anybody other than Elite Screens; (e) abnormal mechanical or environmental conditions; (f) unusual physical or electrical stress -including failure or fluctuation of electrical power, lighting, static electricity, fire, tornadoes, or other natural disasters.

Elite Screens does not warrant against freight damage, concealed or otherwise, unless product is shipped directly from an Elite Screens facility. You must contact the vendor and the delivering carrier to report freight damage within (7) days of receipt. Failure to report freight damages within the carrier's guidelines may result in you bearing all costs.

THIS LIMITED WARRANTY AND REMEDY PROVIDED ABOVE ARE EXCLUSIVE AND IN LIEU OF ALL OTHER WARRANTIES. ELITE SCREENS, INC. DISCLAIMS ALL OTHER WARRANTIES, WHETHER EXPRESS, IMPLIED OR STATUTORY, INCLUDING ANY WARRANTY OF MERCHANTABILITY, ANY WARRANTY OF FITNESS FOR A PARTICULAR PURPOSE AND ANY IMPLIED WARRANTIES ARISING FROM A COURSE OF DEALING OR USAGE OF TRADE. THIS LIMITED WARRANTY GIVES THE END USER SPECIFIC LEGAL RIGHTS, AND THE END USER MAY HAVE OTHER RIGHTS WHICH VARY FROM STATE TO STATE.

EXCEPT AS PROVIDED IN THIS WRITTEN WARRANTY, ELITE SCREENS, INC. SHALL NOT BE LIABLE FOR ANY LOSS, INCONVENIENCE, OR DAMAGE, INCLUDING DIRECT, SPECIAL, INCIDENTAL OR CONSEQUENTIAL DAMAGES, RESULTING FROM THE USE OR INABILITY TO USE THE ELITE SCREENS PRODUCT, OR FOR LOST DATA OR LOST SOFTWARE WHETHER RESULTING FROM BREACH OF WARRANTY OR ANY OTHER LEGAL THEORY. SOME STATES DO NOT ALLOW THE EXCLUSION OR LIMITATION OF INCIDENTAL AND CONSEQUENTIAL DAMAGES, SO THE ABOVE LIMITATION MAY NOT APPLY.

In Canada, warranties include both warranties and conditions. Some jurisdictions do not allow limitations on how long an implied warranty lasts and some jurisdictions do not allow the exclusion or limitation of incidental or consequential damages, so the above limitations and exclusions may not apply to you. This warranty gives you specific legal rights, and you may also have other rights which vary from jurisdiction to jurisdiction.

**International Warranty:** Elite Screens, Inc. does not provide warranty coverage outside of the United States or Canada. For more information on the warranty coverage, terms and conditions in your region, contact your Elite Screens International Distributor directly.