

PS-15 Ply separator



IMPORTANT:

Read this user manual and follow the instructions and warnings before operating this device.

Any modification or transformation performed on this machine may cause loss of the manufacturer's guarantee and liability.

This manual must always remain near to the machine and visible to all the operating and maintenance staff, for any future consultation, forming part of the equipment.

Index:

-Electrical connection to the grid:	3
-Description:	3
-Characteristics:.....	3
-Using instructions:.....	4
- Changing and adjusting the blade:	7
- Stroke adjustment of rollers:	9
- Warnings:.....	11
- Electric schemes :	12
- Parts list:	13
.....	13
CE Declaration of conformity:	20

-.Electrical connection to the grid.

Connect the equipment to a 230 v or 400 v three-phase grid depending on the voltage shown on the technical specifications plate, and its corresponding earth connection, without taking into consideration the direction of the motor rotation. This equipment has a rotation selector.

-.Description.

Ply separator activated by a reducer motor and drive shaft, with manually controlled height adjustment by way of eccentrics.

Support table with adjustable cutting width guide.

Pinch rollers closure activated by compression spring.

-.Characteristics.

Dimensions	481 × 402 × 370 mm (l × w × h)
Weight	31 Kg
Blade width	100 mm
Max. cutting width	160 mm
Max. thickness	20 mm
Voltage	3 × 230 // 400 v. (verify on manufacture plate)
Power	0.37 Kw

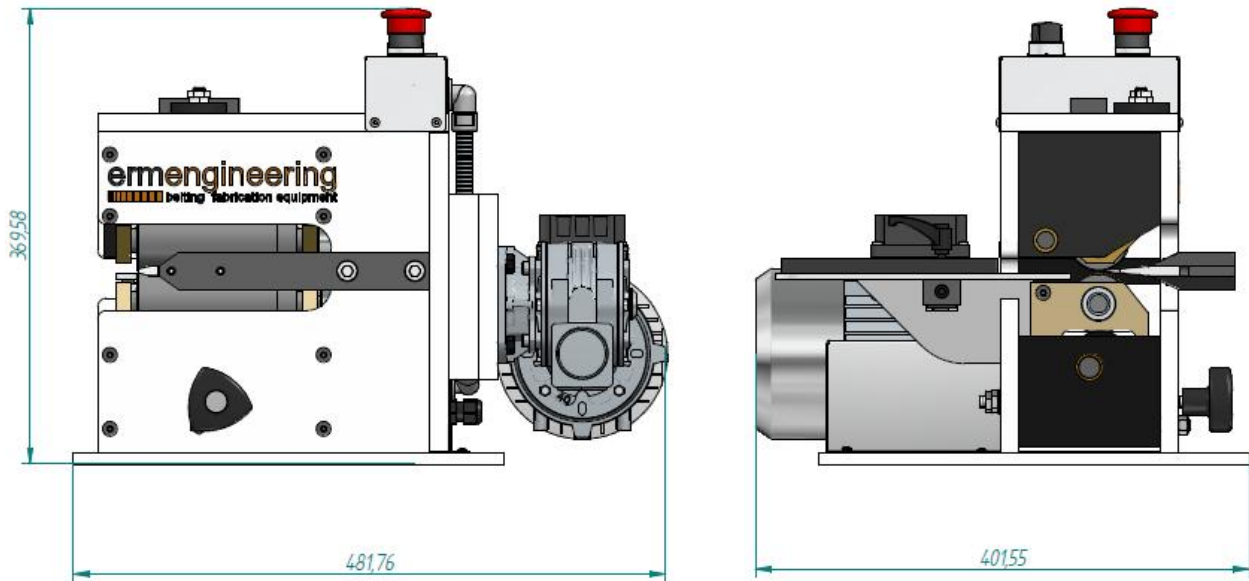

-.Using instructions.

WARNING:

THIS DEVICE INVOLVES THE HAZARD OF HANDS BEING TRAPPED AND CUT BY THE PINCH ROLLERS. THE USER SHOULD EXERCISE GREAT CARE AND PRECAUTION IN THE MATERIAL ENTRY ZONE, AVOIDING THE PLACEMENT OF HANDS IN THIS ZONE.

- Once the equipment is connected to the mains, it must be fixed to a table or support through the four holes in its base, so as to avoid overturning or falls.

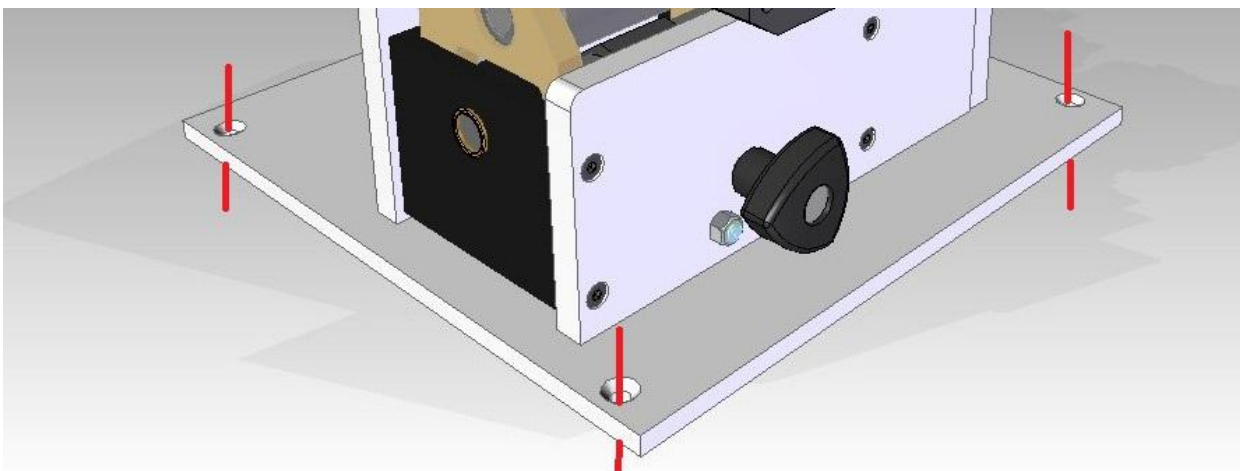

- Always adjust the cutting guide to less than 100 mm, before introducing the material.

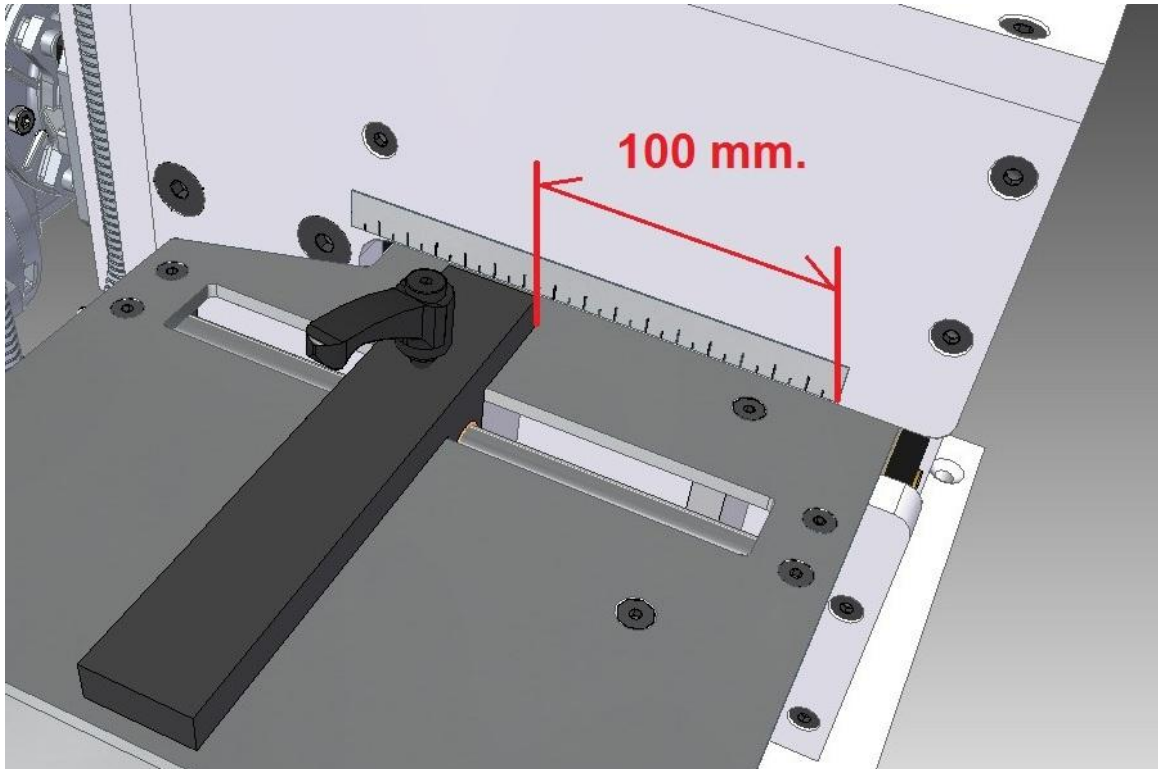

NOTE:

Although the initial cut is 100 mm, we must keep in mind that depending on the toughness of the material used, various passes must be done in order to obtain the desired final width.

- The cutting thickness is adjusted by turning the height regulation control found on the right hand side.



- We can do a test on a corner of the belt, or on a scrap piece of the same material, to see if the height adjustment and pressure is correct.
- We start to ply the belt by applying one or more passes, depending on the hardness or substance of the material being worked on, and depending on the adjustment of the table's opening guide.

-. Changing and adjusting the blade.

WARNING:

When changing the blade, disconnect the power cord from the mains, to avoid accidents.

- Take off the blade support by removing the two M10 Allen screws using an 8 mm Allen key.

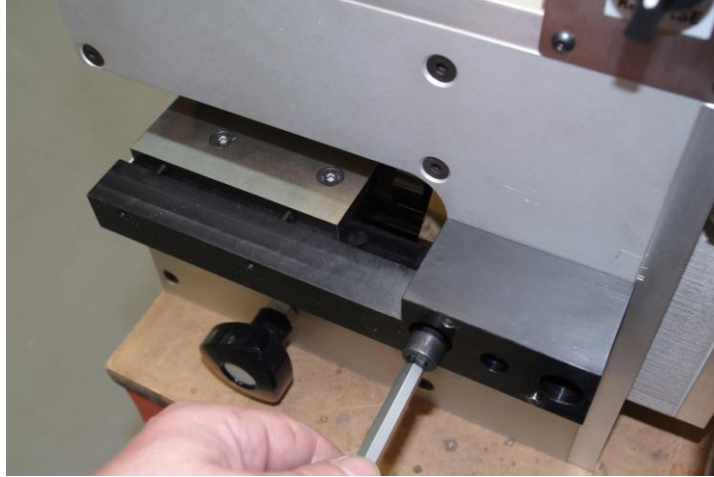

Also, use a 5mm. allen key to help the extraction of the arm.

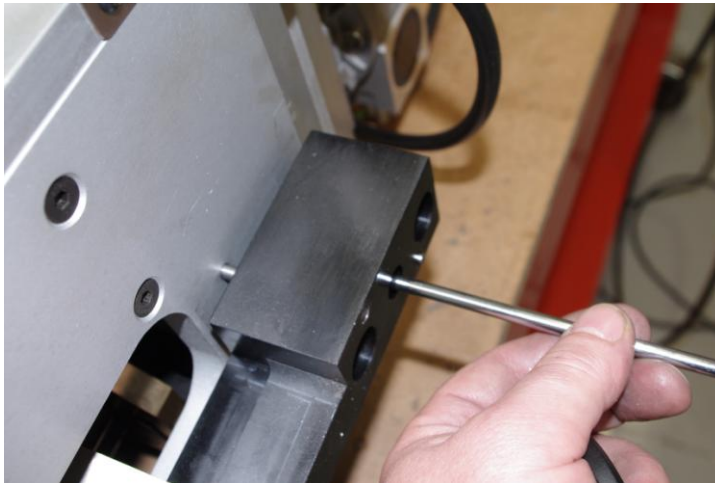

- Once the blade arm assembly has been taken off, loosen the two M8 bolts that fix the blade to the support, with a 13mm key.

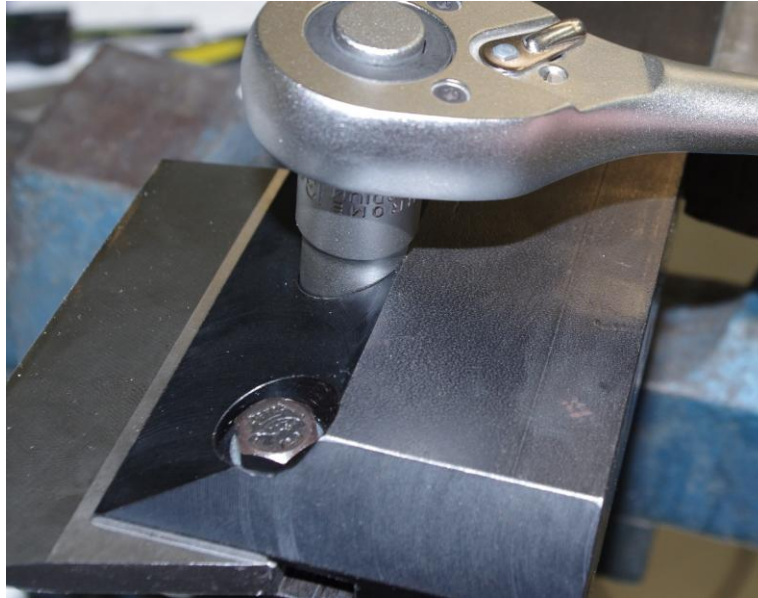

-Remove the old blade and insert the new one, up to the limit set by the two adjustment screws in the rear. These two limiting screws in the rear determine the proximity of the blade to the pinch rollers.

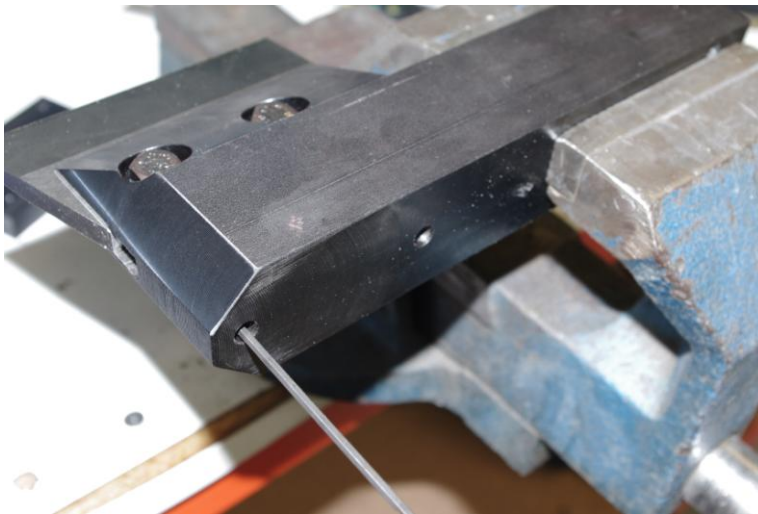

Adjust this measure at 108.5 mm.

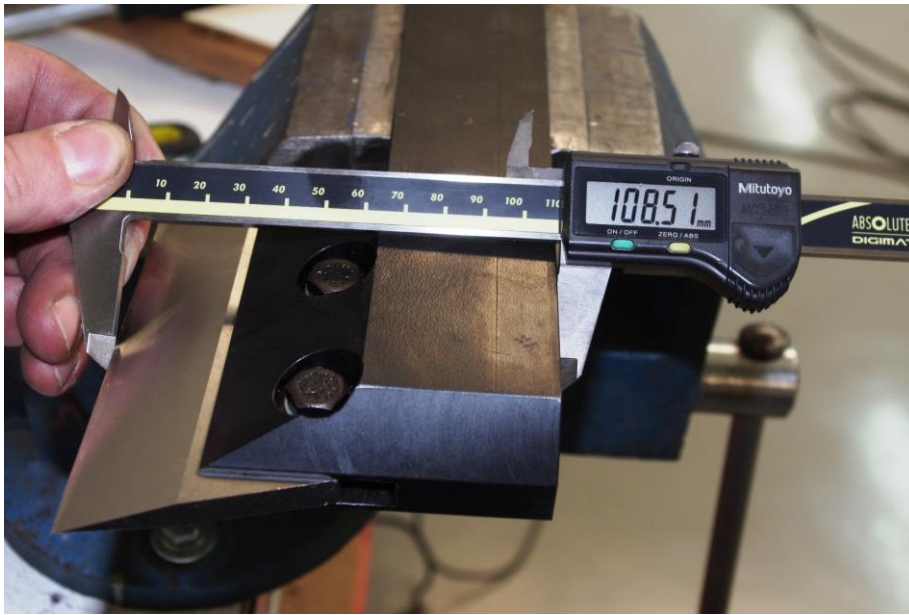

- After changing the blade, reset the support to its original position by firmly tightening the two M8 Allen screws.

-. Stroke adjustment of rollers.

NOTE:

The incorrect stroke adjustment of the rollers may cause the blade's cutting edge to break if they are too close, or on the contrary, may cause poor traction when using thin materials.

- To adjust the height of the upper roller, adjust the M10 screw that is on the upper cover.

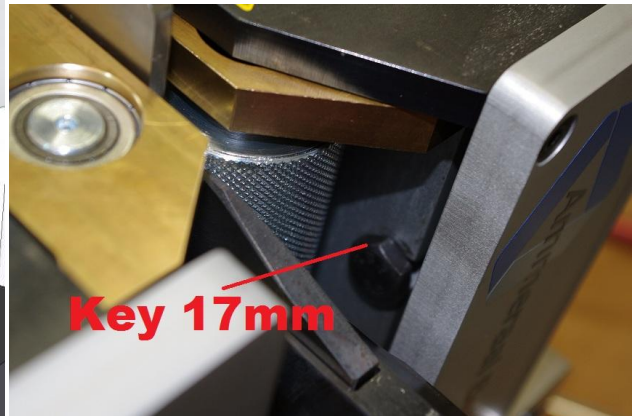
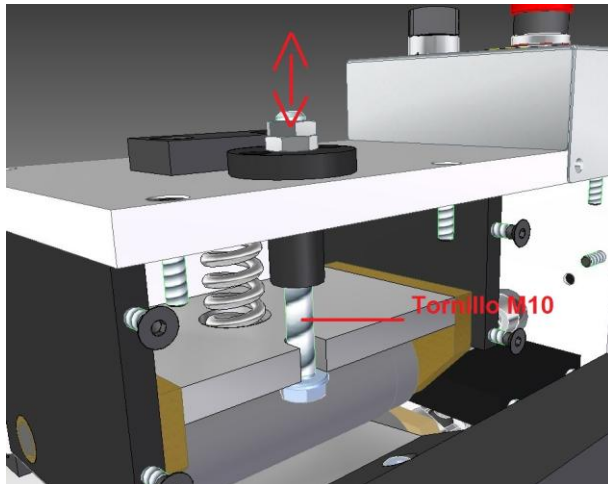

- To adjust the height of the lower roller, adjust the M8 screw that is on the right hand side cover, next to the height regulation control.

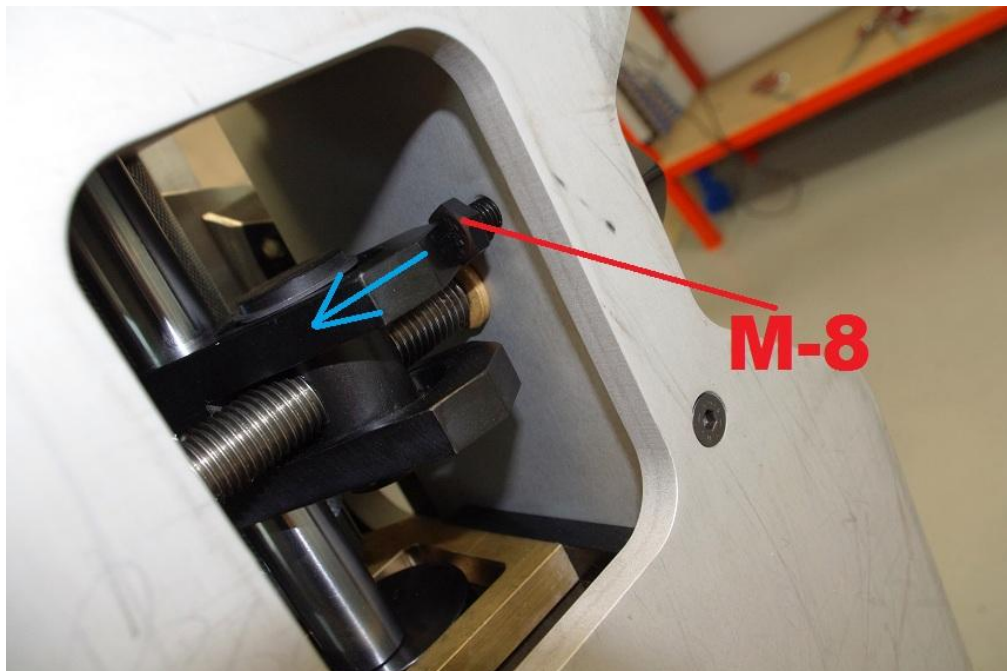

-. **Warnings:**

ATTENTION: Although safety systems are present, due to the nature of functioning of the equipment, there is a high risk of trapping and cutting in the open zone.

-Check the voltage of the equipment before connecting to the mains.

-Do not use the equipment in damp environments or with a wet floor.

-Always work with the equipment fastened to a stable and sturdy base.

-Avoid the use and operation of this equipment by inexperienced or unqualified staff.

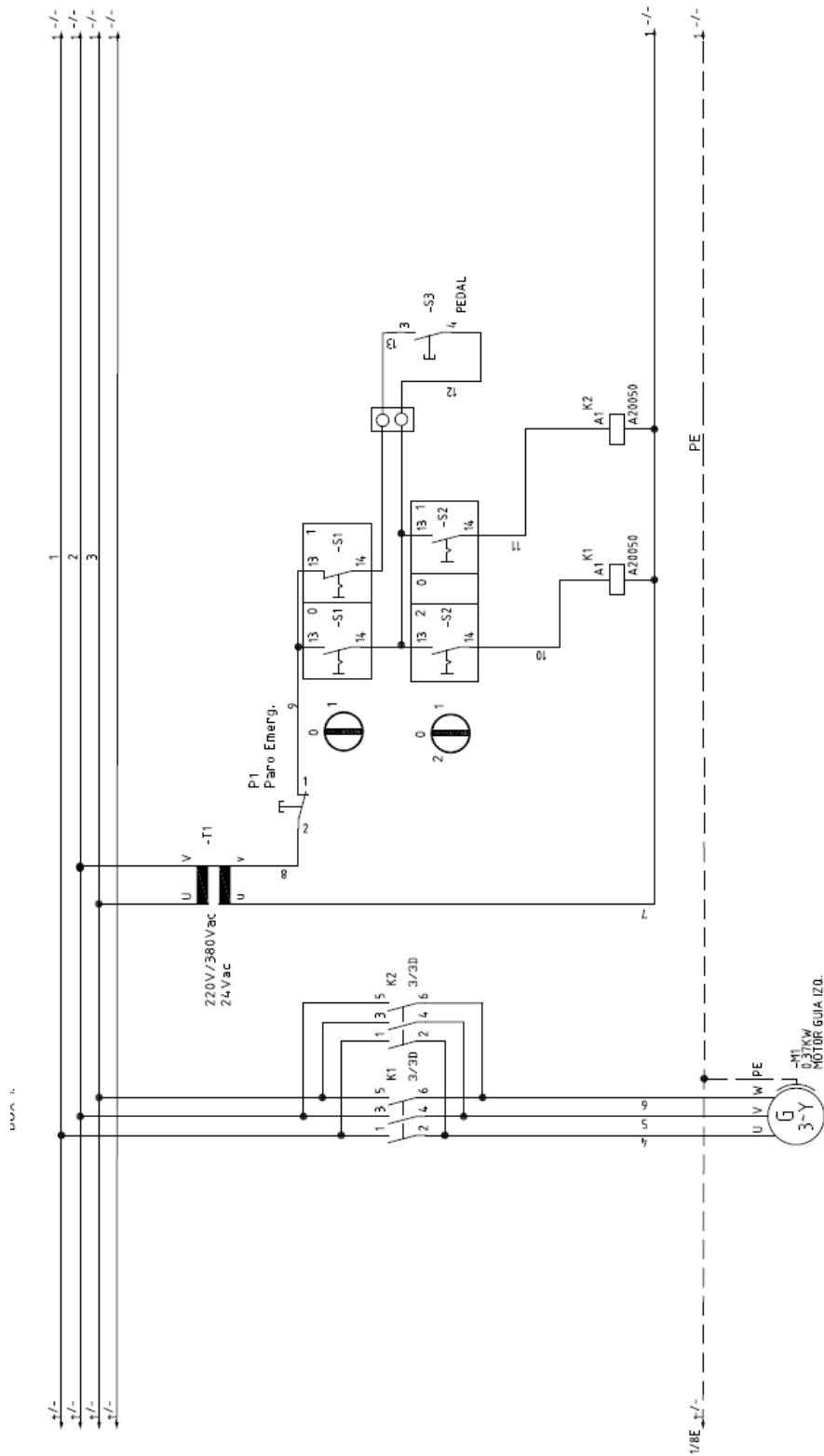

-. Parts list.

Number	Part name	Units
100100	Distancial rodillo SUP,par	1
100101	Brazo rodillo presion,par	1
100102	Brazo rodillo presion 2,par	1
100103	cojinete,PAR	2
100104	Rodillo matriz PS,par	1
100105	Eje basculante,par	1
100106	Diene cuerpo superior 2,par	1
100107	Diene cuerpo superior,par	1
100108	SELFOIL 14-20-10,par	2
100109	Screw_DIN_933_M10x70_v10.00,par	1
100110	Muelle 5M,par	1
100111	Guia tape rodillo,par	1
100112	Screw_DIN_913_19.80_M10x16_v10.00,par	1
100113	Tapeta muelle presion,par	1

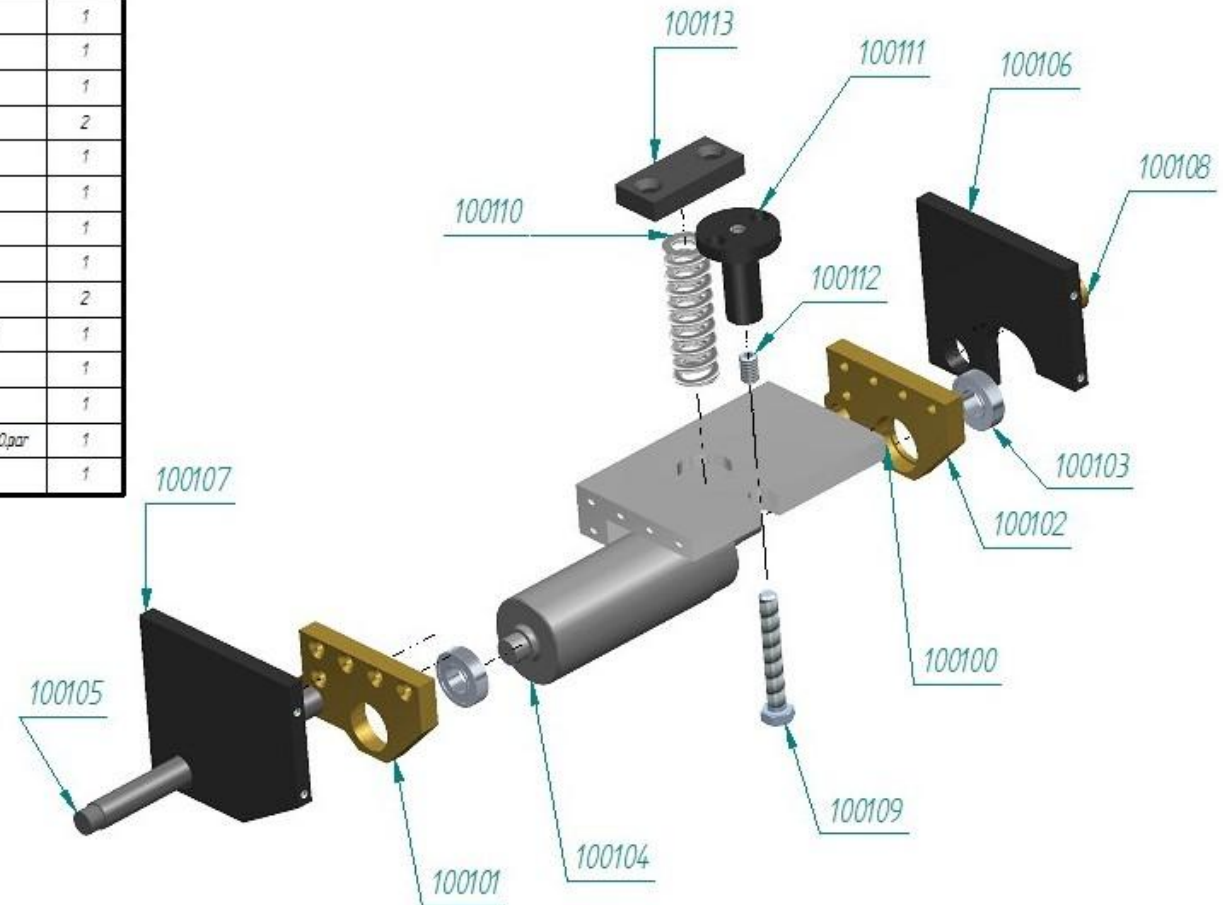

Number	Part name	Units
100200	Guia alza INF.par	2
100201	SELFOL 22X18X12.par	2
100202	Eje para excéntrica.par	1
100203	Excéntrica PS.par	2
100204	Leva para alza.par	1
100205	Eje raspado alza.par	1
100206	Tuerca alzado.par	1
100207	SELF01 ALZA.par	2
100208	vtr_60_b_m10_arancio.par	1
100209	Alojamiento Excent-1.par	1
100210	Alojamiento Excent-2.par	1
100211	Rodillo matriz PS.par	1
100212	cojinete.PAR	2

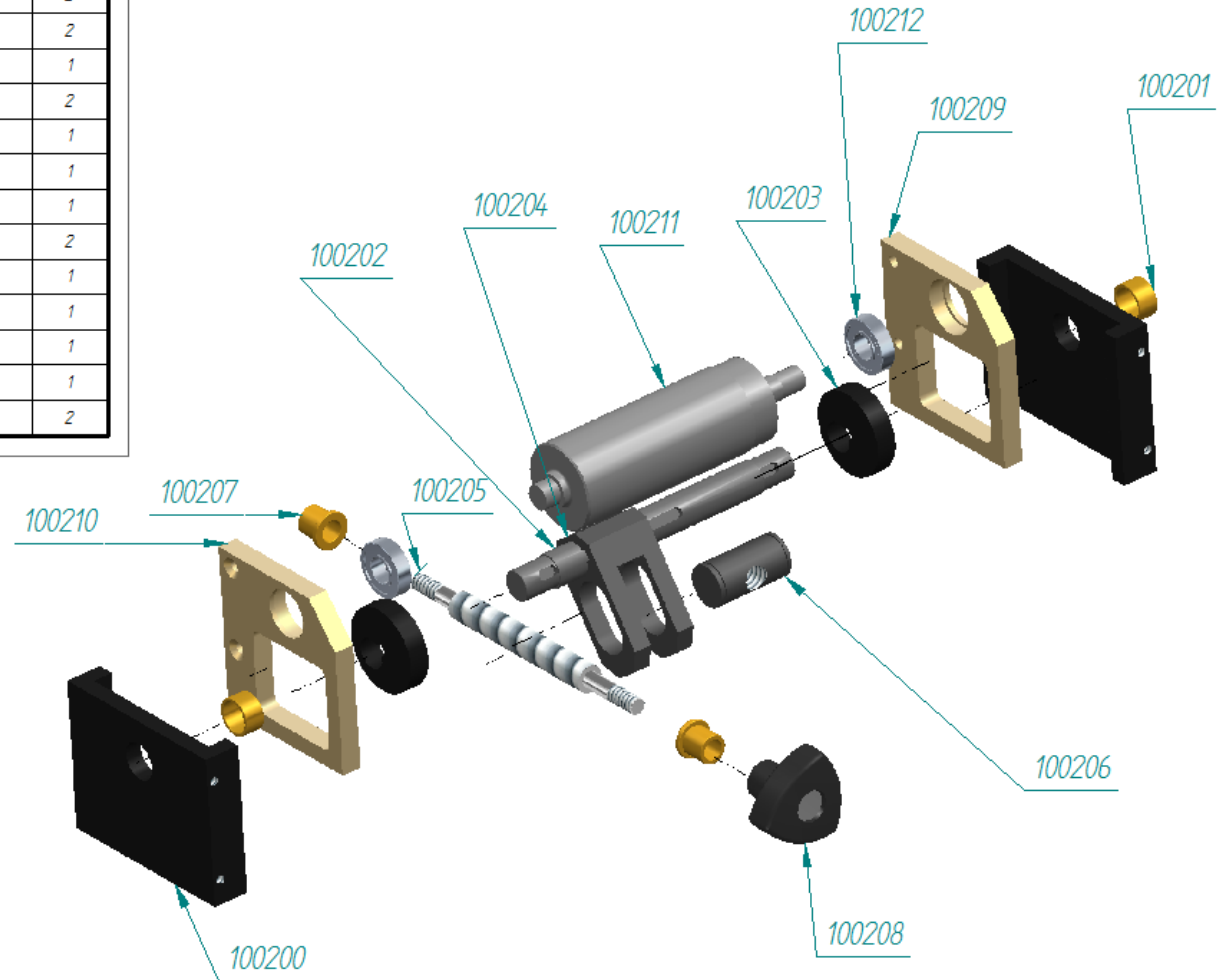

Number	Part name	Units
100500	Soporte para cuchilla PS.par	1
100501	Cuchilla PS-15.par	1
100502	Distancial Soporte.par	1
100503	Screw_DN_912_M10x60_v10.00.par	2
100504	Screw_DN_6912_M8x16_v10.00.par	2
100505	Screw_DN_913_1980_M5x20_v10.00.par	2
100506	Screw_DN_7991_M10x40_v10.00.par	2
100507	Pin_DN_7_1981_5m6x50_v10.00.par	2

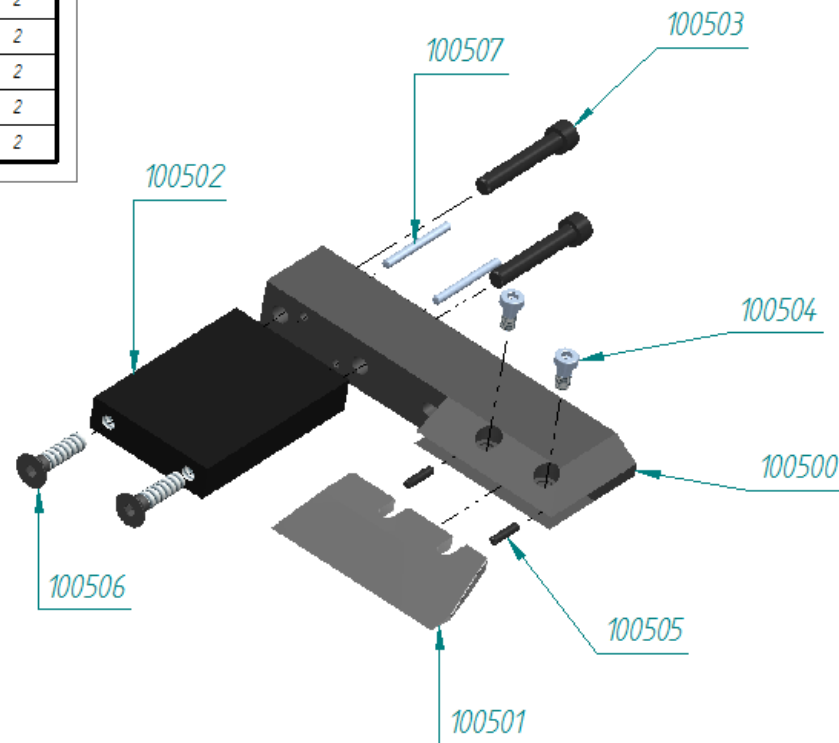

Number	Part name	Units
100300	Soparte mesa,par	1
100301	PATA MESA,par	2
100302	Mesa PS,psm	1
100303	Pestana barra guia,par	2
100304	Barra guia mesa,par	1
100305	Guia banda,par	1
100306	erz_44_p_m6x25,par	1
100307	SEIFOL 15-18-30,par	1
100308	Screw_DIN_7991_M5x12_v10.00,par	8
100309	Screw_DIN_912_M6x16_v10.00,par	2
100310	Screw_DIN_7991_M6x30_v10.00,par	8

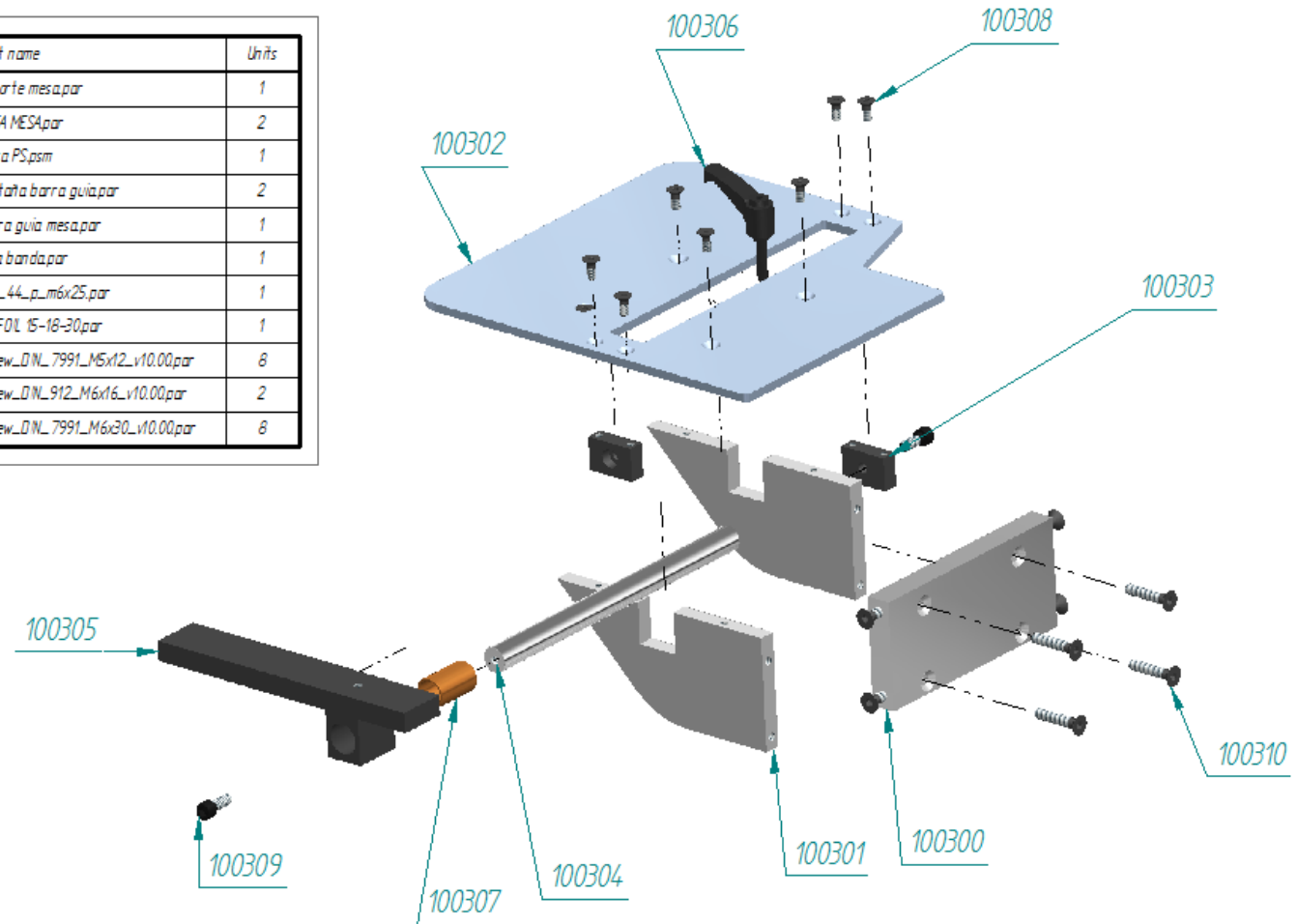

Number	Part name	Units
100400	Placa cierre trasera.par	1
100401	cajinetepar	3
100402	ARANDELA P110.par	2
100403	Eje basculante SUP.par	1
100404	Eje basculante INF.par	1
100405	Placa trasera motor.par	1
100406	Screw_DIN_912_M8x45_v10.00.par	4
100407	Screw_DIN_933_M8x16_v10.00.par	4
100408	Placa sujecion motor.par	1
100409	mid_audd_chailly_A1_32_26_1.par	2
100410	ARANDELA CHAFLANADA.par	1
100411	Screw_DIN_7991_M8x30_v10.00.par	1
100412	T0711E411B1410514X30NO..._A001_STD1H1/H1.asm	1
100413	mid_audd_chailly_A5_472_140000.asm	2

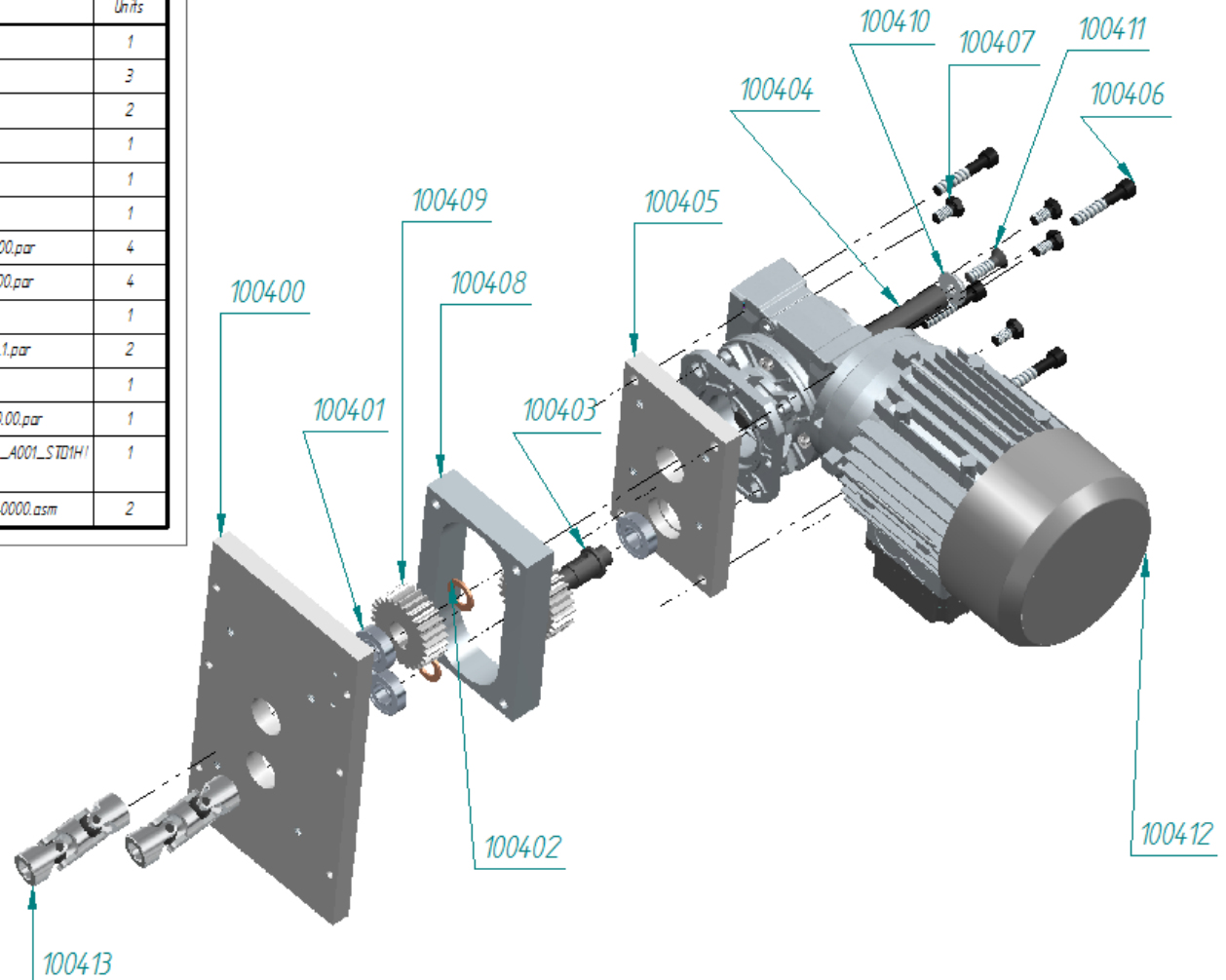

Number	Part name	Units
10600	Cuadro para.psm	1
10601	xb4_bd25.asm	1
10602	Etiqueta marcha.par	1
10603	Paro completo.asm	1
10604	Screw_ISO_7380_M4x10_v10.00.par	4
10605	_VwV_M200HHI.par	1
10606	Piloto.par	1

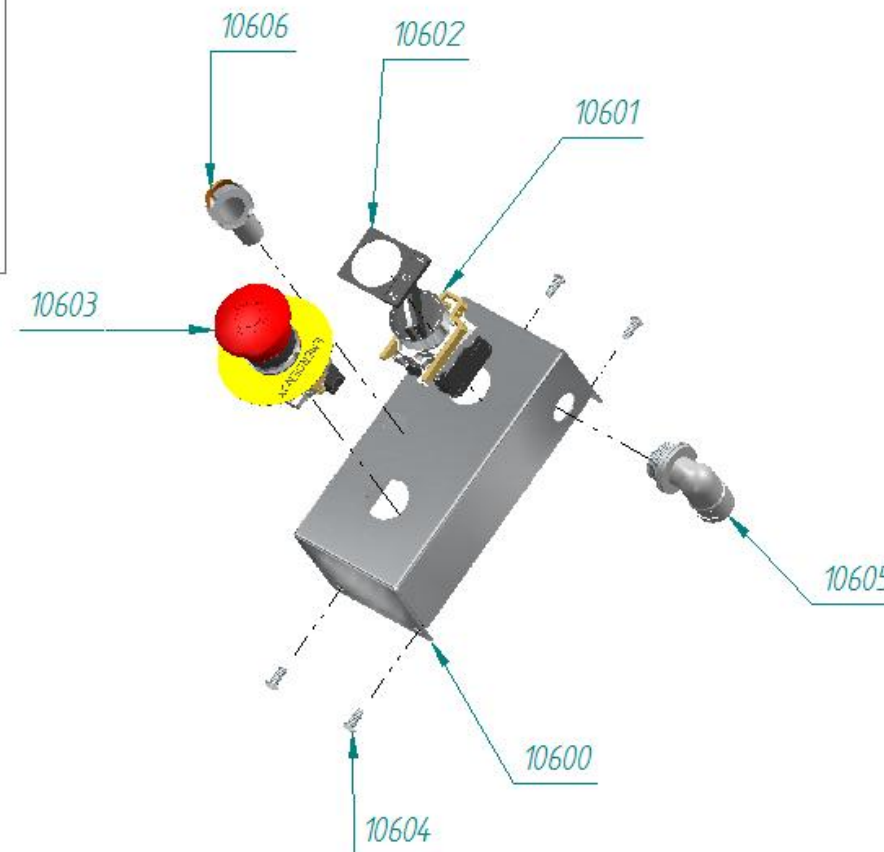

Number	Part name	Units
100700	Placa base.par	1
100701	Placa lateral IZ.par	1
100702	Placa lateral DE.par	1
100703	Placa superior.par	1
100704	Nut_DIN_980_V_M6_v10.00.par	1
100705	Cinta medicion.par	1
100706	TRANSFORMADOR P.D.LUX 25VA.par	1
100707	tc2_k1210_ew.par	1
100708	CUADRO.psm	1

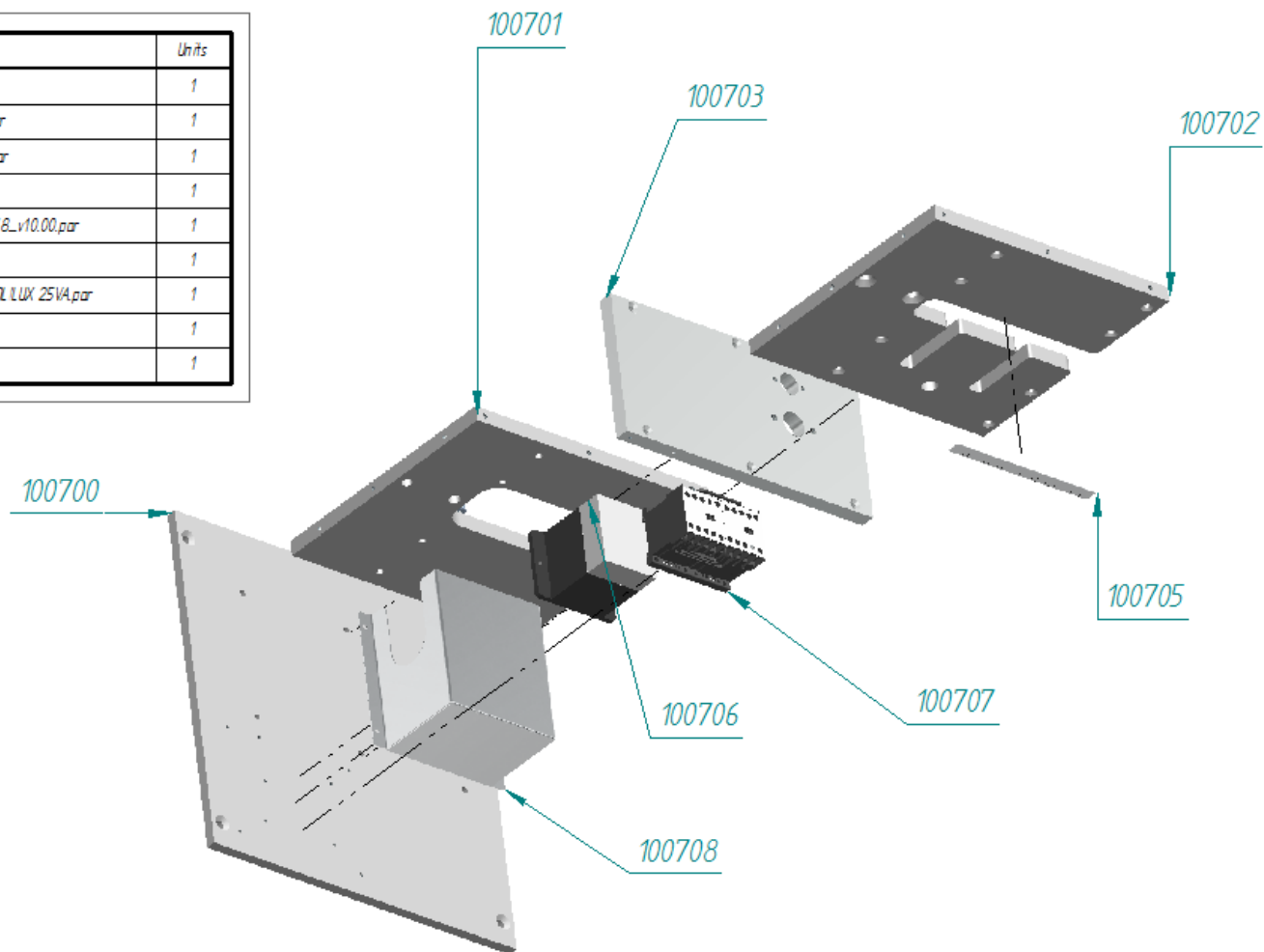

CE Declaration of conformity:

WE DECLARE, under our responsibility, that the machine:

- Type: Ply separator
- Brand: ERM Engineering
- Model: PS-15
- Serial No.: 13855
- Manufacturer date: 2014

Inspired by the directives of the Official Journal of the European Communities:
2006/42/CE

Complies with the design and construction specifications of the European Standards on General Machine Safety:

EN ISO 12100-1
EN ISO 12100-2
EN 60204-1
EN ISO 13250
EN ISO 13857
EN ISO 14121-1

Managing Director: Eduardo Ramos Martínez



ermengineering
belting fabrication equipment

Arenys de Munt (Barcelona)

Date: 2014/11