

CruzPro[®]

MaxDS110

CE



Multifunction Depth/Speed Instrument

Table of Contents

Introduction	5
Installation and Wiring	7
Operation of the MaxDS110	9
Key Functions	9
Turning Power ON/OFF	9
Changing and Controlling Backlight Intensity	9
Selecting a Display Configuration	9
Summary of Display Configurations 1-16	10
Turning Alarms ON/OFF	16
Setting High and Low Alarm Values	16
Setting/Starting Clock/Time-Of-Day Alarms/Race Timers	17
Calibrating a Data Source	19
Setting Display Damping	20
Setting Units of Measure	21
Setting Keel Offset	22
Clear Trip Distance and Trip Time	22
Appendix A - Specifications	23
Appendix B - Packing List	24
Appendix C - Optional Items	25
Appendix D - Typical Setup	26
Appendix E - <i>Important Notes and Warnings</i>	28
Appendix F - Critical Background Alarm Functions	30
Appendix G - Key Function Summary	31
Appendix H - NMEA 0183 Sentences	34
Appendix I - Display Firmware Version and Serial No.	35
Appendix J - Error Codes	36
Index -	37
Other CruzPro Products	40

CruzPro is a trademark of CruzPro Ltd.

Introduction

The MaxDS110 multifunction depth/speed instrument will simultaneously display three sets of data on three digital displays. Depth, boat speed, sea water temperature, trip and total logs, race timers, time-of-day, elapsed trip time and battery voltage can be displayed in a variety of different formats. High and Low alarms can be set for Depth (Deep and Shallow), boat speed, water temperature and battery voltage. Eight (8) different Time-Of-Day alarms can be set to remind you of important radio schedules, weather FAXes, etc. The two race timers can be independently set to any value from 1 to 60 minutes.

A keel offset can be programmed to provide the depth of the water under the keel. Variable display damping (filtering) can be selected for both depth and boat speed. You can switch between sixteen different predefined display configurations with the front panel keys. Changes are automatically saved to a nonvolatile memory.

You can select from five backlight levels (including OFF) and the backlights can be externally activated. The MaxDS110 works on both 12 and 24 VDC and outputs NMEA 0183 data sentences for depth, boat speed, sea water temperature and battery voltage.

A variety of different optional depth and speed/temperature transducers are available in plastic and bronze that mount on the transom or through the hull.

Installation and Wiring

Before starting the installation, please read this entire section first. Finger tighten the screws that mount the instrument bracket - It is not necessary or recommended to use tools.

- Drill a 2-1/8" (55mm) mounting hole where you desire to mount the instrument (Figure 1).
- Remove the adhesive backing protection from the bulkhead gasket and carefully align the waterproof bulkhead gasket on the back of the instrument.
- Connect the various wires as shown in Figure 2.
- Carefully check all your wiring then mount the instrument in the hole. Use only finger tension to tighten the bracket hold-down nuts

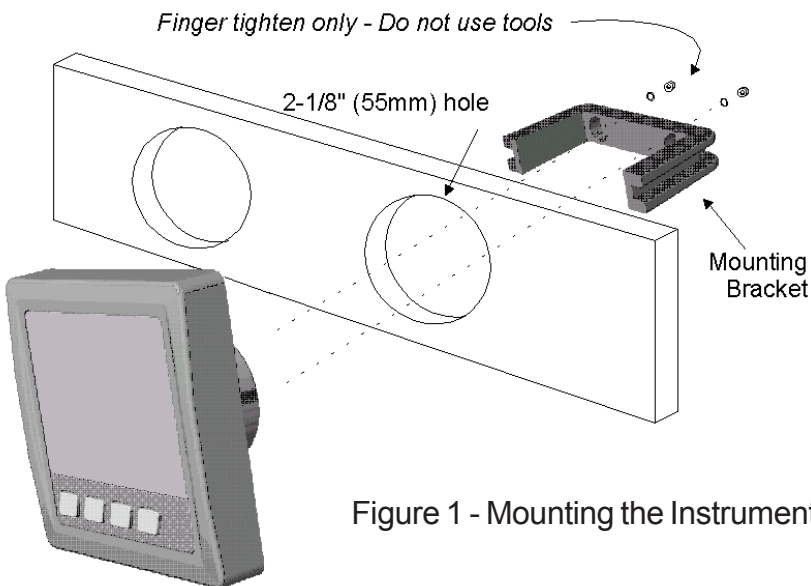
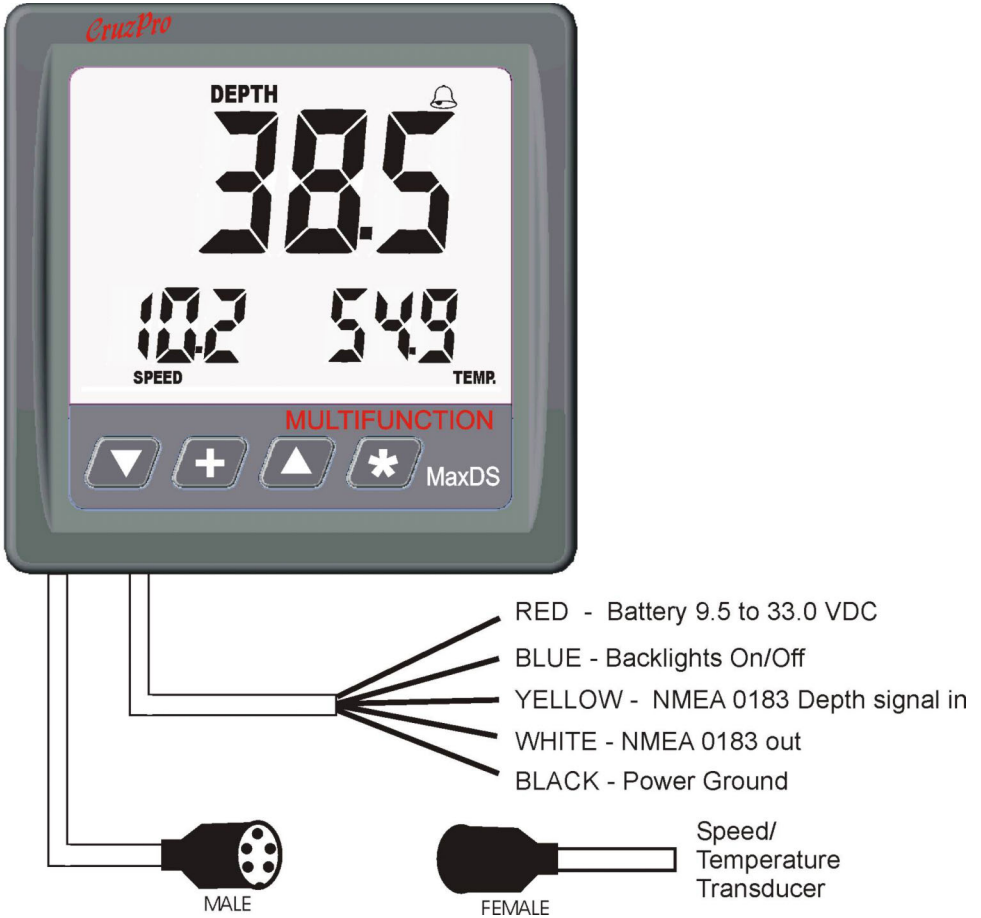

Figure 1 - Mounting the Instrument

Figure 2 - MaxDS110 Wiring Diagram



Operation of the MaxDS110

Key Functions

The ▼, +, ▲ and * keys are used to select and set backlight levels, select display configurations, view/set alarm values and calibrate the instrument. Changes are automatically saved to a nonvolatile memory. A complete summary of all the possible key functions are shown in Appendix C.

Turning Power ON/OFF

Press and hold the * key for five seconds to turn the MaxDS110 display OFF - the clock will keep running. Press and hold the * key for three seconds to re-enable the display. If you remove power from the MaxDS110 the Time-Of-Day clock will have to be set again.

Changing and Controlling Backlight Intensity

Press the + key for 1/2 second to adjust the backlight level for night viewing. Each time you press the + key for 1/2 second, the level will get brighter 1, 2, 3, 4, OFF, 1, 2, ... etc. The backlight ON/OFF wire provides external backlight control and this wire must be switched to +12/24V for the backlights to work.

Selecting a Display Configuration

Simultaneously press both the ▲ and * keys or press both the ▼ and * keys to cycle between the sixteen preconfigured display configurations. All sixteen display configurations are programmed at time of manufacture with the sixteen configurations shown in Figures 4 to 19.

Summary of Display Configurations 1-16

Each time you select a new display configuration the Current Display Configuration number (in this case #1) is displayed for one second as shown in Figure 3. After one second the display shows the data for display configuration #1 as shown in figure 4. All 16 of the factory default display configurations are shown in figures 4-19.

Figure 3 - Current Display Configuration (#1)



Display #1



**Figure 4
Display configuration 1**

Depth (Display #1)
Boat Speed (Display #2)
Sea Water Temperature (Display #3)

Display #2

Display #3



Figure 5
Display configuration 2

Depth
Boat Speed
Time of Day



Figure 6
Display configuration 3

Depth
Boat Speed
Battery Volts



Figure 7
Display configuration 4

Depth
Battery Volts
Sea Water Temperature

Figure 8
Display configuration 5

Depth
 Battery Volts
 Time of Day



Figure 9
Display configuration 6

Boat Speed
 Depth
 Sea Water Temperature



Figure 10
Display configuration 7

Boat Speed
 Depth
 Time of Day





Figure 11
Display configuration 8

Boat Speed
Depth
Race Timer #1 (5 minute factory default)



Figure 12
Display configuration 9

Boat Speed
Depth
Race Timer #2 (10 minute factory default)



Figure 13
Display configuration 10

Boat Speed
Depth
Elapsed Trip Time

Figure 14
Display configuration 11

Boat Speed
 Trip Log
 Depth



Figure 15
Display configuration 12

Boat Speed
 Trip Log
 Sea Water Temperature



Figure 16
Display configuration 13

Boat Speed
 Trip Log
 Time of Day





Figure 17
Display configuration 14

Boat Speed
Trip Log
Total Log



Figure 18
Display configuration 15

Sea Water Temperature
Boat Speed
Depth



Figure 19
Display configuration 16

Sea Water Temperature
Battery Volts
Depth

Turning Alarms ON/OFF

To “arm” the alarms, press and hold the ▲ key 1/2 second. The Bell symbol will be displayed when the alarms are “armed”. To disable the alarms press and hold the ▼ key for 1/2 second. Any press between 1/2 and 2 seconds will work. A press of less than 1/2 second or longer than 2 seconds will be ignored.

Setting High and Low Alarm Values

To View and/or Set the High Alarm value for any of the three current displays, press and hold the ▲ key for ten seconds (until you hear a long beep). To View and/or Set the Low Alarm value for any of the displays, press and hold the ▼ key for ten seconds. The alarm value, display identifier (1, 2 or 3) and the word “HiAL” or “LoAL” will be displayed as shown in Figure 20. Quick press the + key to select the desired display (1, 2, or 3). Press and hold the ▼ or ▲ keys to change the alarm value. Press the + key for 1 second (until the long beep) to accept the new alarm value, save it to memory and exit the Alarm Editor mode.



Figure 20 - Alarm Editor

Editing the Hi alarm
for display #3

To prevent confusion, the High and Low alarm values are unique for each Data Source (Depth, Speed or Temperature, etc.). For example, if you change the high alarm value for Depth in one display configuration, then the high alarm value for Depth will automatically change for each display configuration where Depth is displayed.

Be sure to read the warnings about alarms in the *Important Notes and Warnings* section about which Data Sources and conditions will sound an audible alarm.

Setting/Starting Clock/Time-Of-Day Alarms/Race Timers

Press and hold both the ▼ and ▲ keys for ten seconds (until you hear a long beep) to view and/or set the clock, time-of-day alarms and Race Timer1/Race Timer2. You will see the display shown in Figure 21. The Hours will blink showing which is being changed. Press the * key to switch between changing the Hours or Minutes. Press (or hold) the ▼ and ▲ keys to change the value. Press the + key to cycle through the eight Time of Day alarms and Race Timers. Press the + key for 1 seconds when you are done to save the results to memory.



Figure 21 - Clock/Alarm Editor
Setting Time-Of-Day Clock

Figure 22 shows what you will see when setting the Time-Of-Day alarms. These are set the same way as the clock. Press the + key for 1 seconds when you are done to save the results to memory.



Figure 22 - Clock/Alarm Editor
Setting the eight Time-Of-Day Alarms

Figure 23 shows what you will see when setting Race Timer 2. The race timers are set the same way as the clock. Only the minutes can be set for the race timers. Press the + key for 1 second when you are done to save the results to memory.

To start Race Timer 1 quick press both the ▼ and + keys. To start Race Timer 2 quick press both the + and ▲ keys. You do not have to be viewing the race timers for them to start/run/stop - they will work in the background. The race timers will start counting down from their assigned values and beep as each minute is counted down. When the race timers reach 10 seconds each second will be sounded off with a short beep. When the race timers reach zero you will hear a long beep.

In order to prevent confusion, only one race timer can be running. Starting Race Timer 2 will stop Race Timer1 and vice-versa. Once a race timer has been started it can also be stopped the same way. Restarting the race timers will cause them to reset and start from their original values; not from where they were stopped.



Figure 23 - Setting Race Timer 2

Calibrating a Data Source

Calibrating the displayed data is possible for boat speed, sea water temperature, battery voltage and the clock. Press and hold the **+** and ***** keys for ten seconds to enter the Calibration Editor (until you hear a long beep). The data source value, display identifier (1, 2 or 3) and the word “CAL” will be displayed as shown in Figure 24. Quick press the **+** key to select the desired display (1, 2 or 3). Press and hold the **▼** or **▲** keys to change the calibration. Press the **+** key for 1 second (until the long beep) to accept the new value, save it to memory and leave the Calibration Editor mode.



Figure 24 - Calibration Editor

Editing the calibration for the Data Source shown on digital display #2

When calibrating the Time-Of-Day clock a calibration value between 0 and 100 (nominal value is 50) will be shown on Display #1 and the time of day shown on Display #3. Increase the Clock Calibration value to speed up the clock, decrease the Clock Calibration value to slow down the clock. Increasing the Clock Calibration value by one will increase the clock speed by 1 second per day. Decreasing the Clock Calibration value by one will decrease the clock speed by 1 second per day.

If the selected data source cannot be calibrated (such as Elapsed Trip Time) then “---” will be displayed for the Data Source value as shown here.

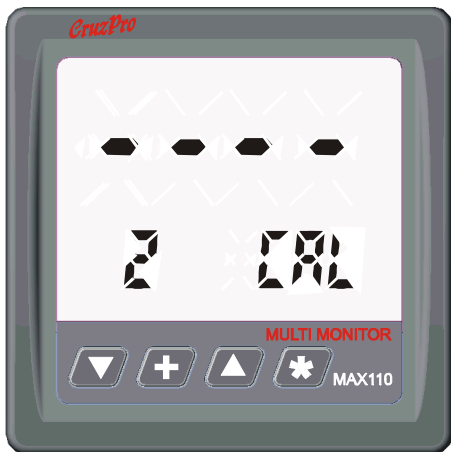

Figure 25 - Calibration Editor

Sample display when attempting to calibrate a Data Source that cannot be calibrated.

Setting Display Damping

It is possible to slow down how fast the numbers on the display change by adding “Display Damping” to the Boat Speed and/or Depth displays. Filter values between 0 (No damping) and 250 (Extremely slow response) are allowed.

Press and hold both the ▼ and * keys for ten seconds to enter the Display Damping Editor (until you hear a long beep). The filter value, display identifier (1, 2, 3) and the word “Filt” will be displayed as shown in Figure 26. Quick press the + key to select the desired display identifier (1, 2, 3). Press and hold the ▼ and ▲ keys to change the calibration value. Press the + key for 1 second (until the long beep) to accept the new value, save it to memory and exit the Display Damping Editor mode.

If the selected data source cannot be filtered (such as Elapsed Trip Time) then “---” will be displayed for the Filter value.



Figure 26 - Display Damping Editor

Setting the Damping Value to “7” for the Data Source shown on digital display #3

Setting Units of Measure

Units of Measure are factory set to Feet, Knots and Degrees F. The clock is set to display in 12 hour format. Press and hold both the ▼ and + keys for ten seconds (until you hear a long beep) to change units to Meters/Fathoms, Miles Per Hour (MPH), Km/Hr, Degrees C and/or to use 24 hour format for the clock. After the long beep the display shown in Figure 27 will be shown. Press the + key to select between Depth, Speed, Degrees or Clock. Press the ▼

or ▲ keys to change the units. Press the + key for 1 second (until the long beep) to accept the new value, save it to memory and exit the Setting Units of Measure mode.



Figure 27 - Setting Units of Measure

Setting the Depth units to “Feet”

Setting Keel Offset

You can enter a Keel Offset value between -50.0 and +50.0 Feet/Meters or Fathoms to modify the depth display. Entering a negative number enables you to display the depth below the keel instead of the depth below the transducer. Entering a positive number enables you to display the actual water depth below the surface instead of the depth below the transducer.

The factory default Keel Offset is 0.0. Press and hold both the **+** and **▲** keys for ten seconds (until you hear a long beep) to view/set the Keel Offset value. After the long beep the display shown in Figure 28 will be shown. Press and hold the **▼** and **▲** keys to change the value. Press the **+** key for 1 second (until the long beep) to accept the new value, save it to memory and exit the Keel Offset Editor Editor mode. If you change units of measure between Feet, Meters and Fathoms, you will need to reset the Keel Offset (if non-zero) so set the Unit of Measure for depth first, before entering a Keel Offset.



Figure 28 - Keel Offset Editor

Sample display when changing the Keel Offset

Clearing Trip Distance and Trip Time

Press and hold the **+** key for 10 seconds (until you hear a long beep) to clear Trip Distance and Elapsed Trip Time to zero.

Appendix A - Specifications

Power supply: 12/24 VDC (9.5 to 33.0), 0.10 A nominal

Operating temperature: 32 to 122 F (0 to 50 C)

Size: 4.3" x 4.3" x 3.5" deep (110 x 110 x 89 mm).

Display: LCD, 3 digital, 16 different configurations

Backlighting: 5 levels (including OFF), plus external backlight On/Off control.

Alarms: Individual high and low alarms for each of the 3 displays and 8 Time of Day alarms (Fax & radio schedules, etc.).

Data Sources/Inputs:

Battery Voltage (To 0.01 VDC)

Boat speed (To 0.01 MPH, Knots)

Clock (12/24 hour format)

Sea water temperature

Depth (from NMEA 0183 \$SDDBT sentence)

Race Timers (2)

Time of Day Alarms (8)

Trip Log

Total Log

Elapsed Trip Time

Outputs: NMEA 0183 depth, speed, sea water temperature and battery voltage data.

Memory: Nonvolatile memory for alarms, current display configuration, calibrations, backlight levels, etc.
Data retention for ten years without power.

Appendix B - Packing List

The MaxDS110 package is supplied with the following items:

- 1) MaxDS110 instrument.
- 2) Dust/rain cover.
- 3) Closed cell foam waterproof bulkhead gasket (adhesive one side).
- 4) Printed user manual.
- 5) Warranty card.

Appendix C - Optional Items

A number of different transducer options are available for the MaxDS110:

Depth Transducer Options:

- 1) ATB120A - 450 ft bronze thru-hull ACTIVE NMEA 0183 transducer.
- 2) ATB120B - 1000 foot bronze thru-hull ACTIVE depth NMEA 0183 transducer.
- 3) ATT120A - 450 foot transom mount ACTIVE depth NMEA 0183 transducer.
- 4) ATT120B - 1000 foot transom mount ACTIVE depth NMEA 0183 transducer.
- 5) ATU120A 450 foot plastic thru-hull mount ACTIVE depth NMEA 0183 transducer.
- 6) ATU120B 1000 foot plastic thru-hull mount ACTIVE depth NMEA 0183 transducer.

Speed/Temperature Transducer Options:

- 1) THST-2 Retractable Plastic Thru-Hull Speed/Temp Transducer with 30' cable and 5 pin Fuji connector.
- 2) THST-3 Retractable Bronze Thru-Hull Speed/Temp Transducer with 30' cable & plug with 5 pin Fuji connector.
- 3) TMST-2 Transom Mount Speed/Temp Transducer with 25' cable with 5 pin Fuji connector.

Appendix D - Typical Setup

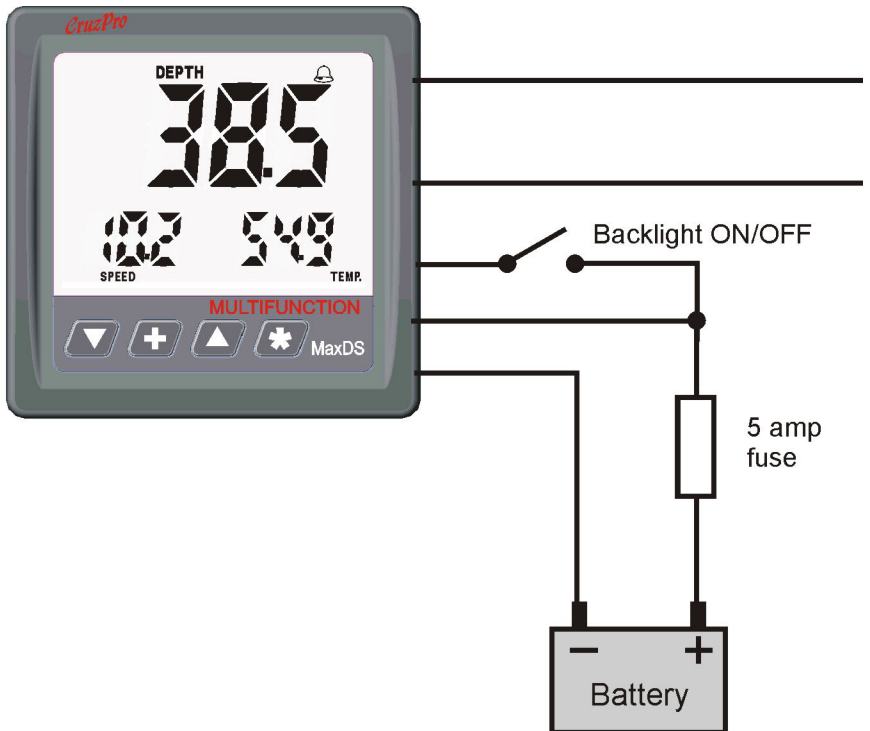

CruzPro ATU120 or
ATT120 or ATB120
Active NMEA 0183
Depth Transducer

(or Depth Sounder
with NMEA 0183
\$SDDBT Output)

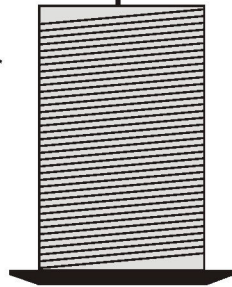

CruzPro THST-2 or
THST-3 or TMST-2
Speed/Temperature
Transducer



Appendix E - Important Notes and Warnings

- 1) The front of the MaxDS110 is splash proof. The back is not sealed and must be protected from water.
- 2) The nonvolatile memory in the MaxDS110 will retain data for a minimum of 10 years without power.
- 3) The lines connecting to the +12/24V Battery should be protected from shorts by placing a 5 amp fuse near the battery side of the connection.
- 4) If you want an alarm to sound for a particular Data Source:
 - a) The alarms must be “armed” (i.e. the Bell symbol must be lit).
 - b) The Data Source value must fall outside the Low or High Alarm limits.
 - c) Only the following Data Sources will activate the alarm:
 - 1) Data Sources being viewed on the display (fast alarm beep)
 - 2) Critical background alarm functions (See list in Appendix E).
- 5) The displayed value will show “----” or “---” if that Data Source cannot be displayed or modified. For example - while you can “Calibrate” Boat Speed you cannot “Calibrate” the total log or “Calibrate” a Elapsed Trip Time. While you can change “Display Damping” on Boat Speed or “Depth” fluctuations, you cannot change “Display Damping” on the total log. “---” or “----” will be also be shown if the displayed number is larger than will fit on the display (e.g. the four digit number 1734 will not fit on 3 digit display).
- 6) The default Units of Measure are Feet, Knots, Nautical Miles and degrees Fahrenheit. Once a unit of measure is selected/changed it will be used for all Data Sources using that unit (i.e. deg F for all temperature displays).
- 7) When Units of Measure are changed, the alarm values are not modified. You must set the Units of Measure first, then set the alarm values or change alarms values manually if you change the Units of Measure.
- 8) Turning Power ON/OFF. The MaxDS110 draws very little power and is intended to have power ON at all times. Press and hold the * key to turn the MaxDS110 display OFF. The clock will keep running. Press and hold the *

key again to enable the display. The Time-Of-Day clock will have to be set again if you remove power to the MaxDS110 but all other data is saved to a nonvolatile memory and not lost.

9) After settings are changed it can take up to 30 seconds to save the data to the nonvolatile memory. If power is removed from the MaxDS110 during this time the changes may not be saved to memory and the older settings will be used when power is reapplied.

10) Both High and Low alarms for Depth data can only be set in full units (i.e. full Feet or full Meters, not tenths).

11) When using the ▼ and ▲ keys to change a value, holding them down will cause the value to scroll fast after three seconds and very fast after ten seconds.

Appendix F - Critical Background Alarm Functions

In addition to sounding the alarms for the functions currently being displayed, the MaxDS110 always monitors the following “Critical” functions in the background regardless of what is being displayed on the screen. ***The alarm will sound only if the alarms are armed, however.***

Priority	Alarm Code	Function
1	27	Depth
2	18	Battery Volts
3	9	Boat Speed
4	15	Time-Of-Day alarms (Up to 8 different)

If one of these critical functions go outside the alarm limits a slow alarm signal will sound and the alarm bell icon will blink. Quick press the * key to silence the alarm and view the alarm code for which alarm has been breached. The display will vary depending on the function as shown in the following examples. Quick press the * key again to view the previous display configuration. The alarm bell icon will continue to blink until you disarm the alarms. If multiple critical alarms are breached the one with the highest priority will be displayed. The critical alarm function and value stay in memory until cleared.

You can continue to toggle between viewing the critical alarm function display and the current display configuration. Once the alarms have been disabled the critical alarm function memory is cleared and viewing is disabled.

Sample Critical Alarm Screen

Sample display when Depth alarm has been breached in the background



Appendix G - Key Function Summary

In normal display mode

Keys	Secs	Function
▼	* 0.1	Scroll DOWN display configurations
▲	* 0.1	Scroll UP display configurations
	* 0.1	Toggle between view Critical Alarms screen and view current display configuration .
▼ +	0.1	Start/Stop Race Timer #1
+ ▲	0.1	Start/Stop Race Timer #2
+ *	0.1	Display Version and Serial Number for 5 seconds
▼	0.5	Disable Alarms (Turns off BELL symbol)
+	0.5	Scroll UP through 5 backlight levels
▲	0.5	Enable alarms (Turns on BELL symbol)
	* 5	Turn Power OFF/ON (Disable/Enable Display)
Keys	Secs	Function
▼	10	Enter "Set Low Alarm Values" Mode
+	10	Clear Trip Distance and Elapsed Trip Time
▲	10	Enter "Set High Alarm Values" Mode
▼ *	10	Enter "Set Display Damping" Mode
+ *	10	Enter "Calibrate Display" Mode
▼ +	10	Enter "Set Units of Measure" Mode
+ ▲	10	Enter "Set Keel Offset" Mode
▼ ▲	10	Enter "Set Time-Of-Day/Alarms/Race Timer" Mode

In “Set Low/High Alarm Values” Mode

Keys	Secs	Function
+	0.1	Scroll through Display Number (1, 2, 3)
▼	0.1	Decrease displayed reading (hold to go faster)
▲	0.1	Increase displayed reading (hold to go faster)
+	1.0	Save new calibration value(s) to memory

In “Set Display Damping” Mode

Keys	Sec.	Function
+	0.1	Scroll through Display Number (1, 2, 3)
▼	0.1	Decrease selected display damping (hold to go faster)
▲	0.1	Increase selected display damping (hold to go faster)
+	1.0	Save new value(s) to nonvolatile memory

In “Calibrate Displays” Mode

Keys	Secs	Function
+	0.1	Scroll through Display Number (1, 2, 3)
▼	0.1	Decrease displayed reading (hold to go faster)
▲	0.1	Increase displayed reading (hold to go faster)
+	1.0	Save new calibration value(s) to memory

In “Set Units of Measure” Mode

Keys	Secs	Function
+	0.1	Select Depth, Speed, Temperature or 12/24 Hr
▼	0.1	Scroll through the possible units
▲	0.1	Scroll through the possible units
+	1.0	Save new units of measure to memory

In “Set Keel Offset” Mode

Keys	Secs	Function
▼	0.1	Decrease the Offset value (hold to go faster)
▲	0.1	Increase the Offset value (hold to go faster)
+	1.0	Save new units of measure to memory

In “Set Time-Of-Day/Alarms/Race Timer ” Mode

Keys	Secs	Function
+	0.1	Select Time-Of-Day, Alarm1, Alarm2, etc.
*	0.1	Switch between setting Hours and Minutes
▼	0.1	Decrease value (hold to go faster)
▲	0.1	Increase value (hold to go faster)
+	1.0	Save new value(s) to memory

Appendix H - NMEA 0183 Sentences

The MaxDS110 outputs NMEA 0183 serial data for use with remote data repeaters or data logging hardware. The data consists of the \$IIXDR sentence and contains data for Depth, Boat Speed, Sea Water Temperature and Battery Voltage in that order.

A sample of the \$IIXDR sentence is shown here:

```
$IIXDR,G,038.5,,G,10.22,,G,054.9,,G,13.83,,G,,MaxDS110*69
```

Where the depth is 38.5, the boat speed is 10.22, the water temperature is 54.9 in the selected units of measure and the battery voltage is 13.83 VDC.

Appendix I - Display Firmware Ver. and Serial Number

Quick press both the **+** and ***** keys to display the current Firmware Version and the product Serial Number for five seconds.



Appendix J - Error Codes

The internal software that runs the MaxDS110 instrument can detect and display some software and hardware errors. A listing of those error codes and their meaning as shown below.

- 0 Contents of internal nonvolatile memory are corrupted and factory defaults are being used. Please check and set/reset all alarm values, etc.
- 1 Unable to communicate with micro U101 - contact dealer
- 2 Unable to communicate with micro U201 - contact dealer
- 3 Unable to communicate with micro U301 - contact dealer
- 4 Unable to communicate with micro U401 - contact dealer
- 5 Contents of nonvolatile memory corrupted and factory defaults are being used. Please check and set/reset Total Log.
- 6 Supply voltage below the minimum 11.2 VDC required to update data to the nonvolatile memory. Check power.
- 7 Unable to program or read nonvolatile memory - contact dealer.
- 8 Error reading Current Configuration Data from nonvolatile memory. Contact dealer if unable to reprogram.
- 9 Not used
- 10 Not used
- 11 Not used
- 12 Error reading logs from nonvolatile memory - contact dealer.
13. Activation code error - contact dealer.

Index

A

Alarm 3, 16, 23
alarm 9, 28
Alarm Code 30
Alarms 16, 31
armed 28

B

background alarm 28
Backlight 9
backlight 9

C

Calibrate 3, 18, 19, 23
calibrate 9, 20, 23
Calibrating the Time-Of-Day clock 19
Clearing Trip Distance and Trip Time Logs 22
Clock Calibration 19
critical functions 30
Critical Background Alarm 30

D

Damping 3, 20, 21, 31, 32
damping 5
Data Source 3, 19, 20, 21, 28
data source 20
Data Sources 23, 28
Display Configuration 3, 9, 10
display configuration 9, 10

E

Error Codes 36
errors 36

F

fast alarm 28
Firmware Version and Serial Number 35

fuse 28

H

Hours and Minutes 33

K

Key Functions 3, 9

key functions 9

N

NMEA 3, 5, 34, 40

nonvolatile memory 28

nonvolatile 32

Notes and Warnings 28

O

ON/OFF 9

P

Power ON/OFF 9

S

scroll fast 29

Serial Number 35

Specifications 23

start Race Timer 18

T

Time-Of-Day 33

Turn Power OFF/ON 31

Turning Power ON/OFF 9, 28

U

Units of Measure 3, 21, 28

W

Warnings 28

User Notes

Other CruzPro Products

- Depthsounders/w Keel Offset, Deep/Shallow/Anchor Drag Alarms
- PC Based DSP Fishfinder for Windows 98, NT, SE, XP, 2000
- Speed/Temperature/Logs
- 34 Function Multi-Function Gauge
- Digital DC Volts Gauge/w Alarms
- Digital DC Volts Gauge/w Alarms for 3 Battery Banks
- Digital Amps Gauge
- DC Volts/Amps/Amp-Hour Monitors
- AC Volts/Amps/Freq/kW Monitors
- LPG/Petrol Gas Detectors/Alarms
- Bilge Water Alarms/w Stainless Steel Water Sensor
- Intelligent Bilge Pump Controllers/w Stainless Steel Water Sensors
- Intelligent Windlass Controller/Chain Counters
- Digital Fuel Gauges & Fuel Consumption Calculator
- Digital Tank Level Gauges for 1 or 3 Tanks/w Separate Alarms
- Smart 4 step Alternator Regulator
- Marine Security System/w Reliable Intrusion Sensors
- RPM/Engine Hours/Elapsed Time Gauges/w Alarm
- Digital Engine Temperature Gauge/w Alarms
- Digital Oil Pressure Gauge/w Alarms
- Digital Temperature Gauges for 1 or 3 Areas/w Alarms
- Digital Clock/Watch/Race Timers/w 8 Alarms
- 8 and 16 Amp Light Dimmers/ Motor Speed Controller
- Solar Panel Charge Controllers 6/8/9 & 20 Amps
- 4 & 8 Channel NMEA Combiners/RS-232 Convertors
- Engine/Exhaust Temp. Monitor & Digital Pyrometer
- NMEA 0183 Remote Data Repeaters/w 4 and 8 Input Channels
- High Pressure Digital Hydraulic Pressure Gauge
- Engine Hours/Elapsed Trip Time/Engine Maintenance Alarm Gauge

email: info@cruzpro.com

website: www.cruzpro.com