

EtherTRAK™

Industrial Ethernet Managed Switches

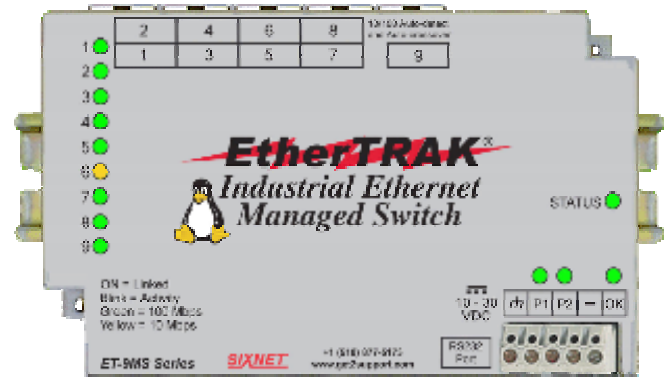

Contents at a Glance:

Section 1	General Information	Page 3
Section 2	LED Indicators	Page 4
Section 3	Installation / Mounting	Page 5
Section 4	Power Wiring	Page 10
Section 5	Communication Wiring	Page 11
Section 6	Technical Specifications	Page 13
Section 7	Service Information	Page 15

Applicable standards and certifications:



This manual applies to the following products:

- **ET-5MS-#** 5-port managed Ethernet switch with 5 10/100 ports
- **ET-5MS-MDM-#** 5-port managed Ethernet switch with integrated telephone modem
- **ET-9MS-#** 9-port managed Ethernet switch with 9 10/100 ports
- **ET-9MG-#** 9-port managed Ethernet switch with 6 10/100 and 3 Gigabit ports
- **ET-10MG-#** 10-port managed Ethernet switch with 8 10/100 and 2 Gigabit ports
- **ET-16MS-#** 16-port managed Ethernet switch with 16 10/100 ports
- **ET-18MG-#** 18-port managed Ethernet switch with 16 10/100 and 2 Gigabit ports

SIXNET Protected Technology Policy - SIXNET protects your investment in SIXNET systems with long-term planned technology and our unique Protected Technology Policy. We will continue to support the specified capabilities of standard SIXNET products for at least five years (twenty years for Industrial Managed Switches). We plan each product improvement and new feature to be upward compatible with existing designs and installations. Our goals are to make each new software release bring new power to your SIXNET systems and have every existing feature, applications program and data file continue to work. We protect your investment even further with a liberal five-year trade-in policy. Exchange standard products for upgraded versions of the same product to take advantage of new features and performance improvements at any time for five years. A prorated trade-in allowance will be given for your existing equipment. SIXNET protects your long-term productivity with state-of-the-art planned technology and continued support.

SIXNET Statement of Limited Warranty - SIXNET, manufacturer of SIXNET products, warrants to Buyer that products, except software, manufactured by SIXNET will be free from defects in material and workmanship. SIXNET's obligation under this warranty will be limited to repairing or replacing, at SIXNET's option, the defective parts within one year of the date of installation, or within 18 months of the date of shipment from the point of manufacture, whichever is sooner. Products may be returned by Buyer only after permission has been obtained from SIXNET. Buyer will prepay all freight charges to return any products to the repair facility designated by SIXNET. This limited warranty does not cover losses or damages which occur in shipment to or from Buyer or due to improper installation, maintenance, misuse, neglect or any cause other than ordinary commercial or industrial applications. In particular, SIXNET makes no warranties whatsoever with respect to implied warranties of merchantability or fitness for any particular purpose. All such warranties are hereby expressly disclaimed. No oral or written information or advice given by SIXNET or SIXNET's representative shall create a warranty or in any way increase the scope of this warranty. This limited warranty is in lieu of all other warranties whether oral or written, expressed or implied. SIXNET's liability shall not exceed the price of the individual units, which are the basis of the claim. In no event shall SIXNET be liable for any loss of profits, loss of use of facilities or equipment, or other indirect, incidental or consequential damages.

INSTALLATION AND HAZARDOUS AREA WARNINGS - These products should not be used to replace proper safety interlocking. No software-based device (or any other solid-state device) should ever be designed to be responsible for the maintenance of consequential equipment or personnel safety. In particular, SIXNET disclaims any responsibility for damages, either direct or consequential, that result from the use of this equipment in any application. All power, input and output (I/O) wiring must be in accordance with Class I, Division 2 wiring methods and in accordance with the authority having jurisdiction.

**WARNING
(EXPLOSION HAZARD)** SUBSTITUTION OF COMPONENTS MAY IMPAIR SUITABILITY FOR CLASS 1, DIVISION 2 (ZONE 2).

**WARNING
(EXPLOSION HAZARD)** WHEN IN HAZARDOUS LOCATIONS, DISCONNECT POWER BEFORE REPLACING OR WIRING UNITS.

**WARNING
(EXPLOSION HAZARD)** DO NOT DISCONNECT EQUIPMENT UNLESS POWER HAS BEEN SWITCHED OFF OR THE AREA IS KNOWN TO BE NONHAZARDOUS.

FCC Statement - This equipment has been tested and found to comply with the limits for a Class B digital device, pursuant to Part 15 of the FCC Rules. These limits are designed to provide reasonable protection against harmful interference in a residential installation. This equipment generates, uses and can radiate radio frequency energy and, if not installed and used in accordance with the instructions, may cause harmful interference to radio communications. However, there is no guarantee that interference will not occur in a particular installation. If this equipment does cause harmful interference to radio or television reception, which can be determined by turning the equipment off and on, the user is encouraged to try to correct the interference by one or more of the following measures: Reorient or relocate the receiving antenna; Increase the separation between the equipment and receiver; Connect the equipment into an outlet on a circuit different from that to which the receiver is connected; Consult the dealer or an experienced radio/TV technician for help.

Copyright & Trademarks - Copyright ©2005 SIXNET, All Rights Reserved. EtherTRAK is a registered trademark of SIXNET.

Note: All information in this document is subject to change without notice.

Section 1

General Information

Overview

This manual will help you install and maintain the Managed Switches. Installation of these managed switches will enable the user to wire redundant connections between nodes, manage the network by monitoring/gathering network data, allow for browser or telnet configuration, increase network performance, and more.

Note: This manual only covers the installation and wiring of these switches. Refer to the separate **Software User Manuals** for details on configuring and using any of the management functions such as **SNMP, RSTP, IGMP, port mirroring, etc.**

Operation

Unlike an Ethernet hub that broadcasts all messages out all ports, the Managed Switches will intelligently route Ethernet messages only out the appropriate port. Most importantly, unlike a regular Ethernet switch, very resilient networks can be implemented because the Managed Switch has the intelligence to detect and allow for ring and mesh Ethernet topologies. In other words, implementing this switch will optimize the network for optimal bandwidth conditions, reduce the number of collisions, and allow for redundant data path connections to reduce/eliminate downtime.

To further aid in network reliability and performance, SNMP is available to extract and exchange network statistical information. Through the use of SNMP, various groups of statistical information can be obtained such as TCP, RMON, IP, and more to aid the user’s job to extrapolate the “health” of the network.

The Managed Switches can support 10BaseT (10 Mbps), 100BaseT (100 Mbps) and 1000BaseT (1000Mbps) on their RJ45 ports (depending on the model). Each of these ports will independently auto-sense the speed, allowing you to interface to regular, fast or gigabit Ethernet devices. Some models also have one or two 100BaseF (100 Mbps) or 1000BaseF (1000 Mbps) fiber optic ports.

Performance Specifications

These general specifications apply to the Managed Switches. Refer to Section 7 for complete technical specifications.

5, 9, 10, 16 or 18 Ethernet ports
Ethernet Switch Type: Managed with SNMP, RSTP, IGMP, VLANs and much more
Ethernet Protocols: All standard IEEE 802.3
RJ45 Ports (shielded): 10/100 or 10/100/1000 (with auto-negotiation, auto-crossover and auto-polarity)
Fiber optic port speed: 100 or 1000 Mbps depending on transceiver installed
Fiber optic wavelength: 850, 1300, 1310 or 1550 nm depending on transceiver installed

Standards and Safety



The Managed Switches meet the following standards plus others:

- Electrical safety** - UL 508, CSA C22; EN61010-1 (IEC1010)
- EMI emissions** - FCC part 15, ICES 003, EN55022; Class B
- EMC immunity** – IEC61326-1

Hazardous locations – UL 1604, CSA C22.2/213 (Class 1, Div. 2), Groups A, B, C, D; Cenelec EN50021 and ATEX (Zone 2)

Install the Managed Switches in accordance with local and national electrical codes.

Lightning Danger: Do not work on equipment during periods of lightning activity.

Do not connect a telephone line into one of the Ethernet RJ45 connectors.

Section 2

LED Indicators

Overview

The Managed Switches have communication LEDs for each port, an “OK” output LED, a status LED and power LEDs. Refer to the sample pictures below for the location of these LEDs.

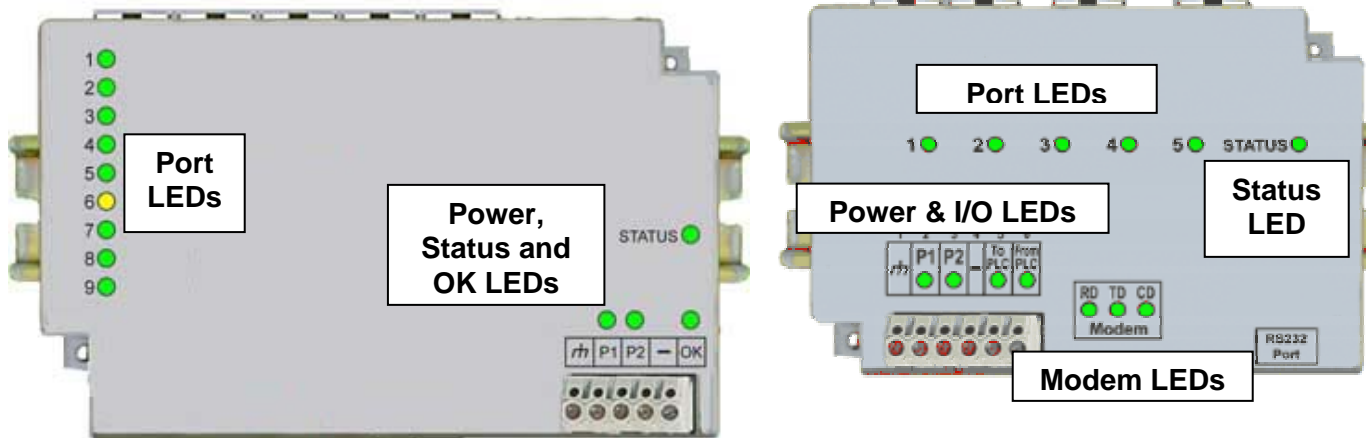

Typical LED Location on the Managed Switches (varies with model)

Status LED

The Status LED indicates the overall health of the switch. It is normally ON solid indicating that no internal CPU or software problems are detected. It will flash when loading firmware and briefly on power up or reset. Otherwise, if it is OFF or flashing for an extended period of time then a problem is detected. In this case, please contact your switch supplier for support.

Power LEDs

There are two Power LEDs on the Managed Switch that are above the P1 and P2 terminals. P1 is used for primary power and P2 is used for secondary power. Both indicate if there is power applied to the respective terminal.

ACT / LNK / (10/100) LEDs

The port LEDs are multifunctional and indicate link confirmation, activity, and speed.

Off	Indicates that there <u>is not</u> a proper Ethernet connection (Link) between the port and another Ethernet device. Make sure the cable has been plugged securely into the ports at both ends.
On Solid (not flashing)	Indicates that there <u>is</u> a proper Ethernet connection (Link) between the port and another Ethernet device, but no communications activity is detected.
Flashing	Indicates that there is a proper Ethernet connection (Link) between the port and another Ethernet device, and that there is communications activity.
Red	A 1000 Mbps (1000BaseT) connection is detected.
Green	A 100 Mbps (100BaseT) connection is detected.
Yellow	A 10 Mbps (10BaseT) connection is detected.

OK LED

This LED indicates the status of the power inputs. There is an output screw terminal that can be connected as shown in Figure 4A and 4B. The output voltage from the screw terminal marked ‘OK’ will be the same as the applied switch input voltage. The output will be ON when both the PI and P2 terminals have power applied to them. It will be OFF if either input does not have power or the switch software is not running.

To / From PLC LEDs

These LEDs are found on the Ethernet Modem managed switch only. The “To PLC” output LED indicates the status of the corresponding output signal. The LED will be ON when the output is true. The “From PLC” output LED indicates the status of the corresponding input signal. The LED will be ON when the input signal is true. Refer to the Software User Manual for details on when these signals are true or false.

Modem LEDs

These LEDs are found on the Ethernet Modem managed switch only. There are three LEDs: RD (Receive Data), TD (Transmit Data) and CD (Carrier Detect). The RD and TD LEDs will flash when data is received or sent, respectively. The CD LED will be ON when a valid dial-in or dial-out connection is detected. Refer to the Software User Manual for details on the modem capabilities.

Section 3

Installation

Overview

The Managed Switches can be snapped onto a standard DIN rail (EN50022) or screwed directly to a flat panel. Refer to the mechanical drawing below. **Note:** Make sure to allow enough room to route your Ethernet and/or fiber optic cables.

Note: The Managed Switches are designed to snap tightly to a standard 35mm DIN rail. This is done by hooking the top (connector side) of the switch on the DIN rail first and then pushing in on the bottom side until you hear a click. However, if the DIN rail is misshapen or bent you may need to use a screwdriver to slide the integral clip away from the switch as you install it to the DIN rail. Once the switch is flat to the DIN rail then you can release the clip for proper attachment. See below.

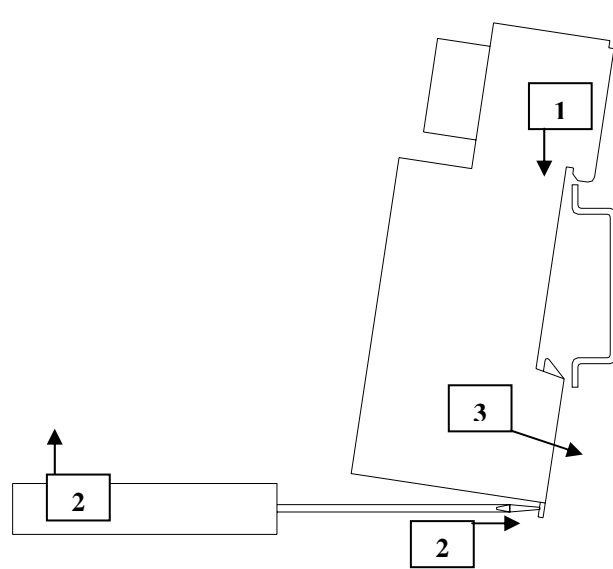

Recommended mounting steps:

1. Hook top back of unit over the din rail.
2. Insert screwdriver into the din clip and pry it away from the unit.
3. Push bottom back onto the din rail and release clip.
4. The unit is now mounted.

Recommended dismounting steps:

1. Insert screwdriver into din clip and pry it away from the unit.
2. Pull bottom of unit away from din rail and release clip.
3. Unhook top of unit from din rail.
4. The unit is now removed.

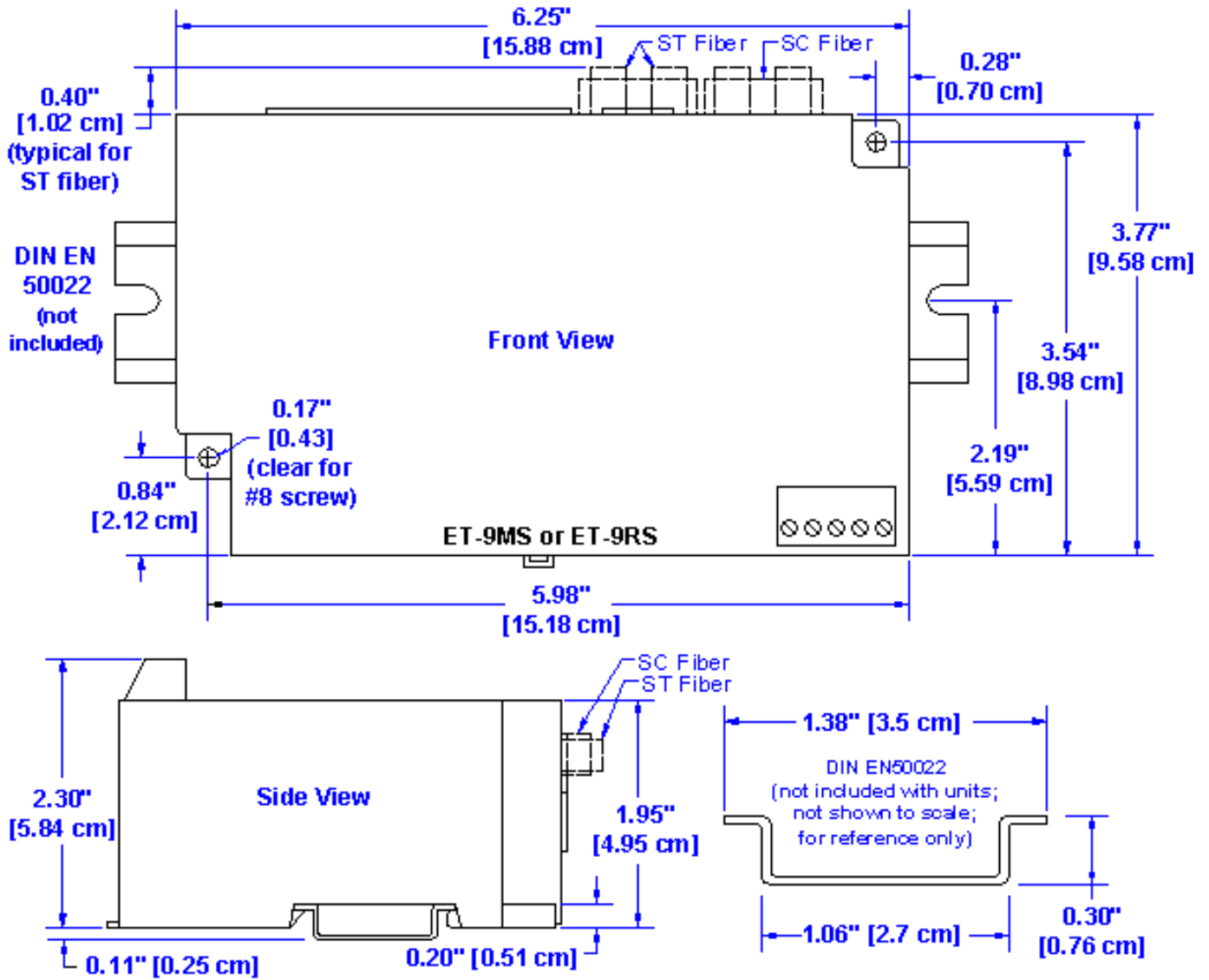

Mechanical Dimensions for 9-Port 10/100 Models

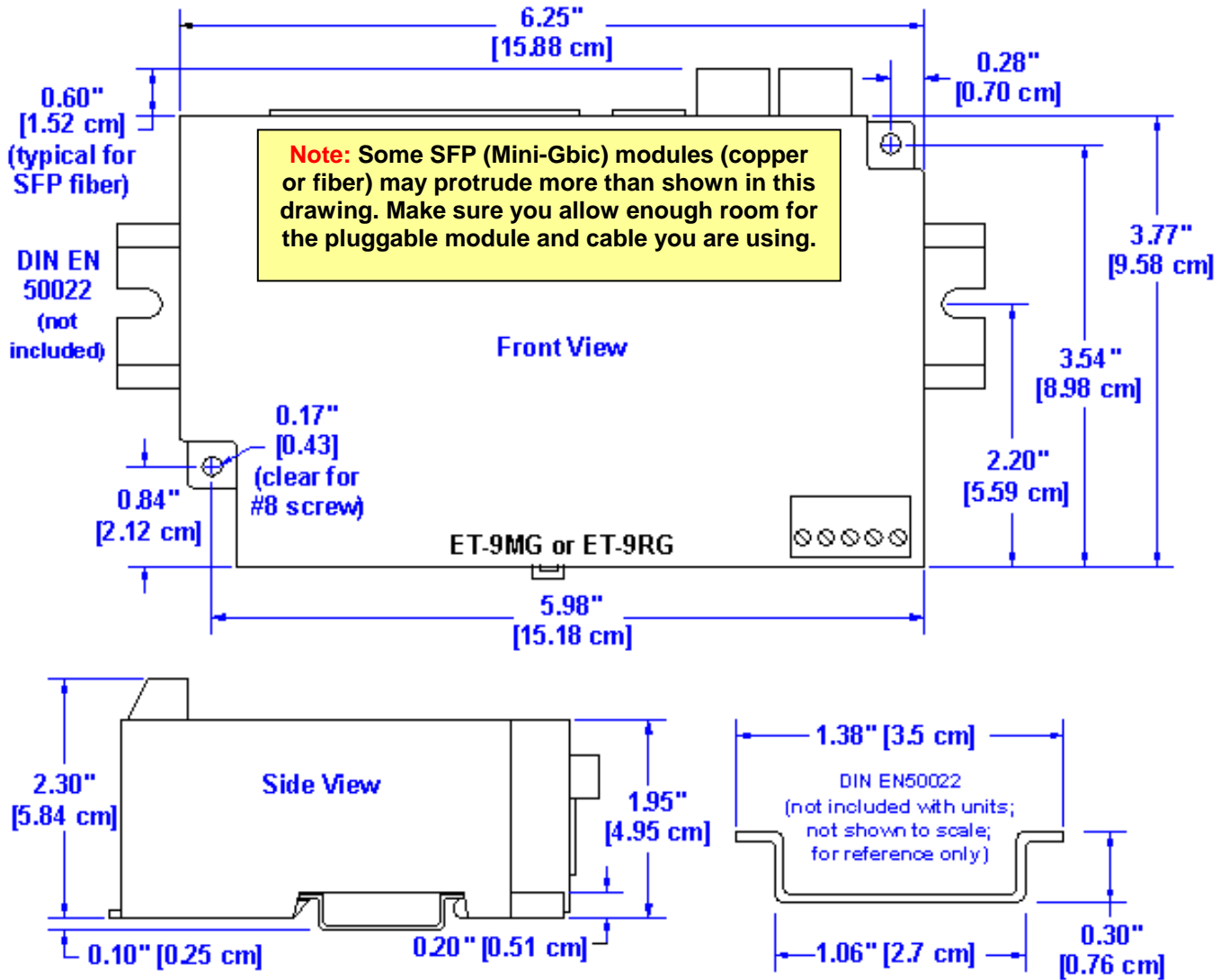

Mechanical Dimensions for 9-port Models with Gigabit

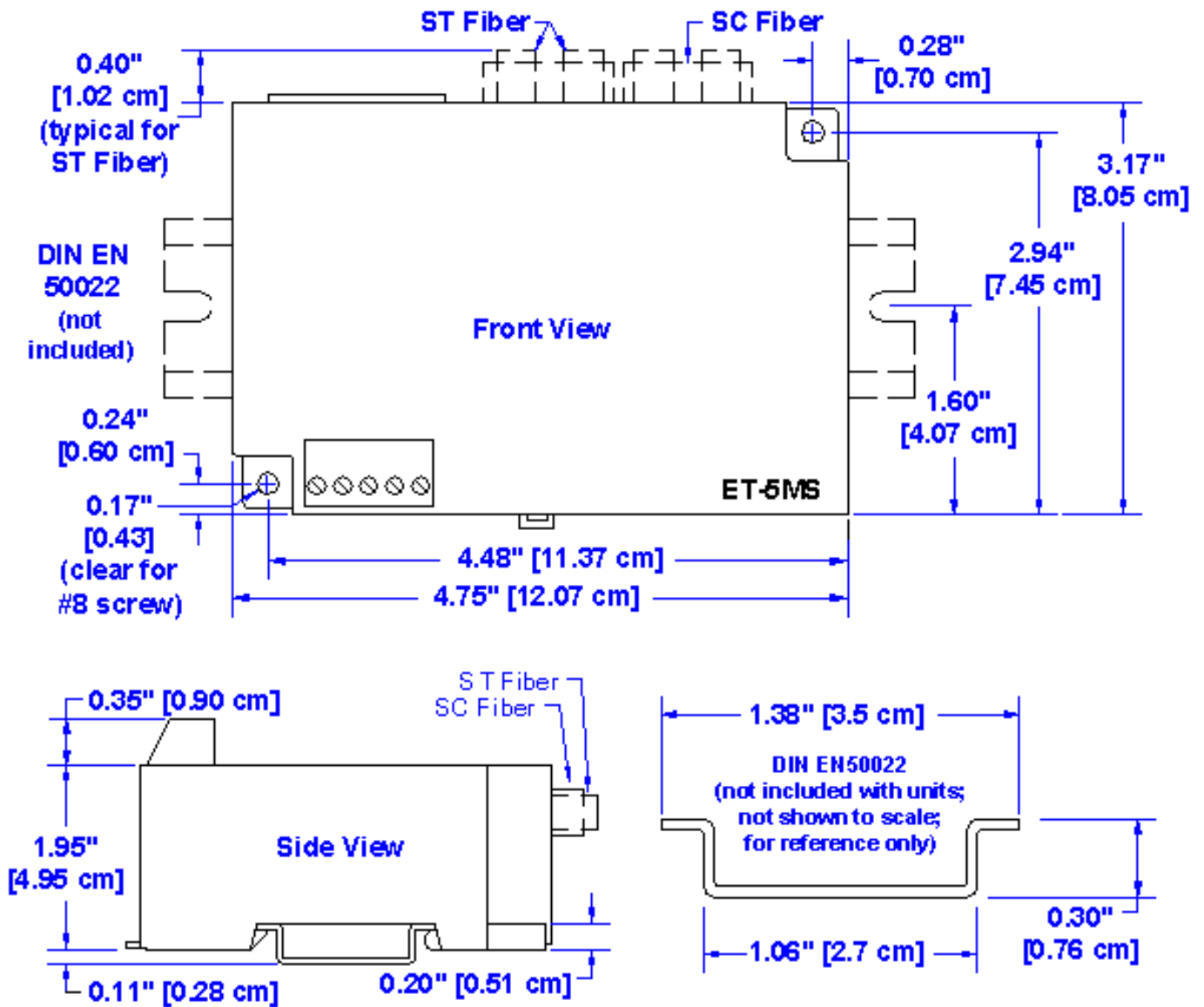

Mechanical Dimensions for 5-Port 10/100 Models

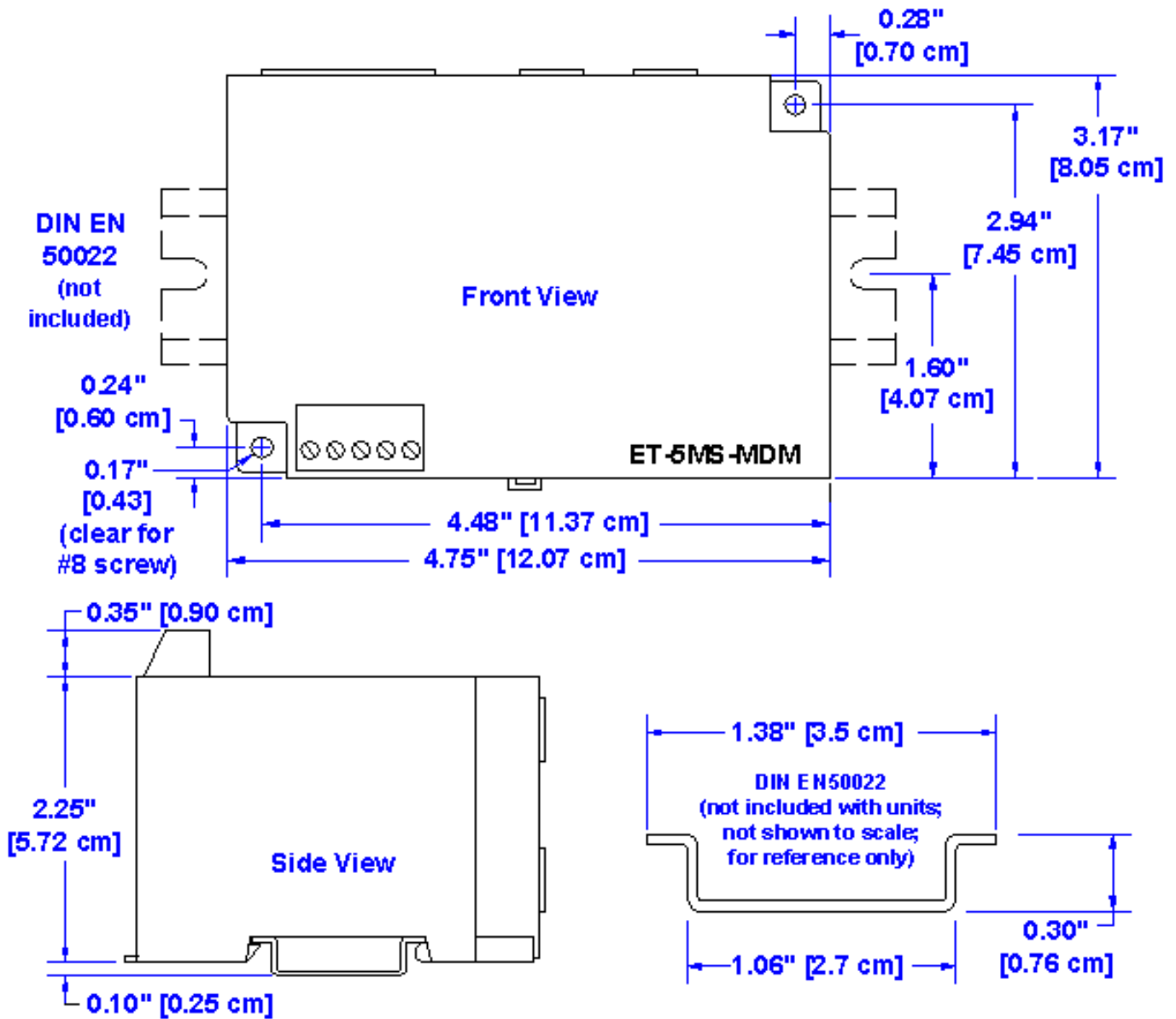

Mechanical Dimensions for 5-Port Model with Modem

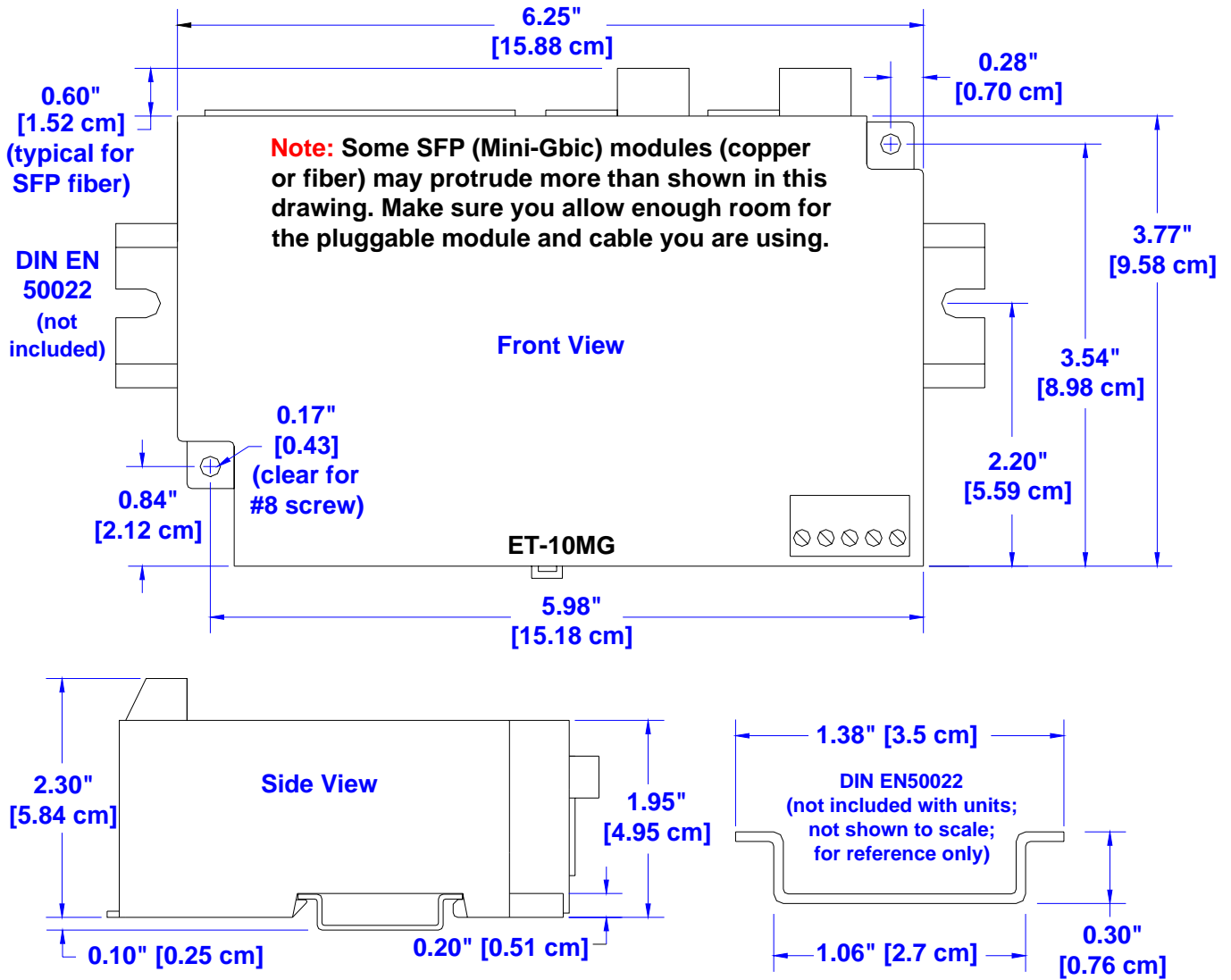

Mechanical Dimensions for 10-Port Models with Gigabit

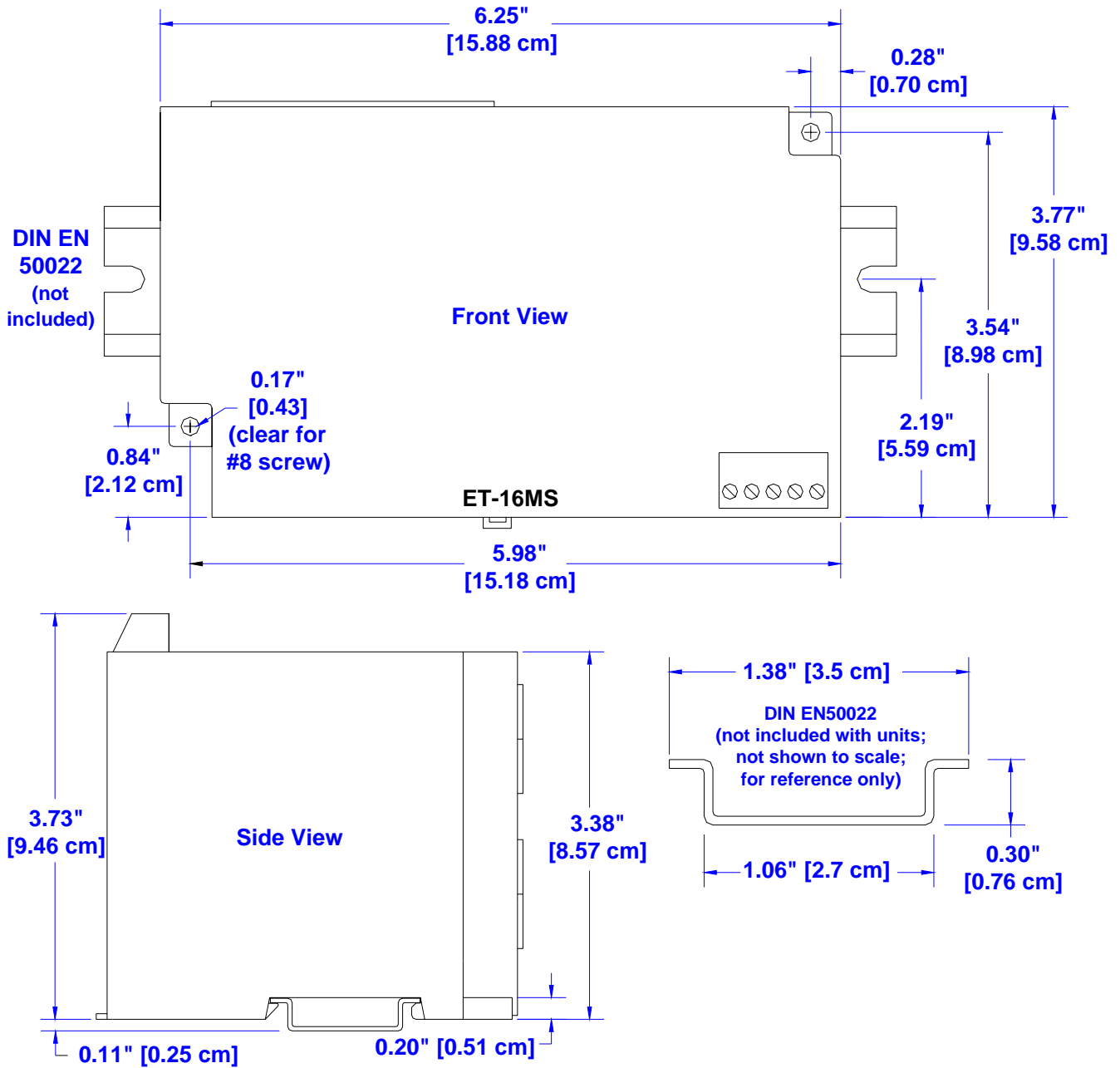

Mechanical Dimensions for 16-Port 10/100 Models

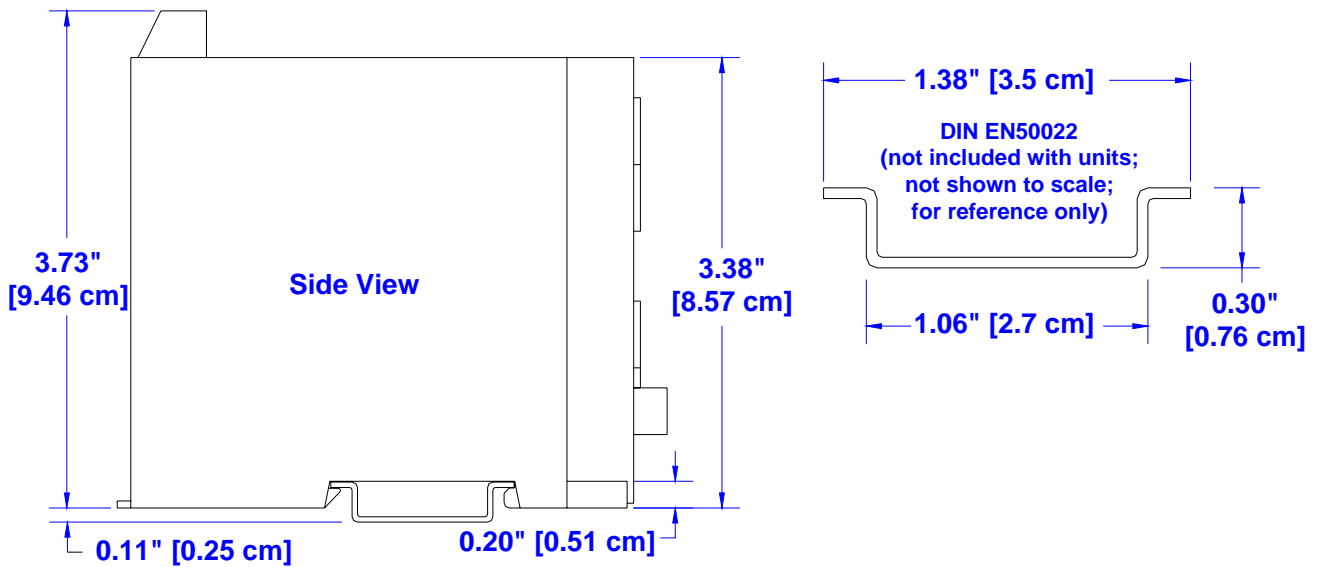
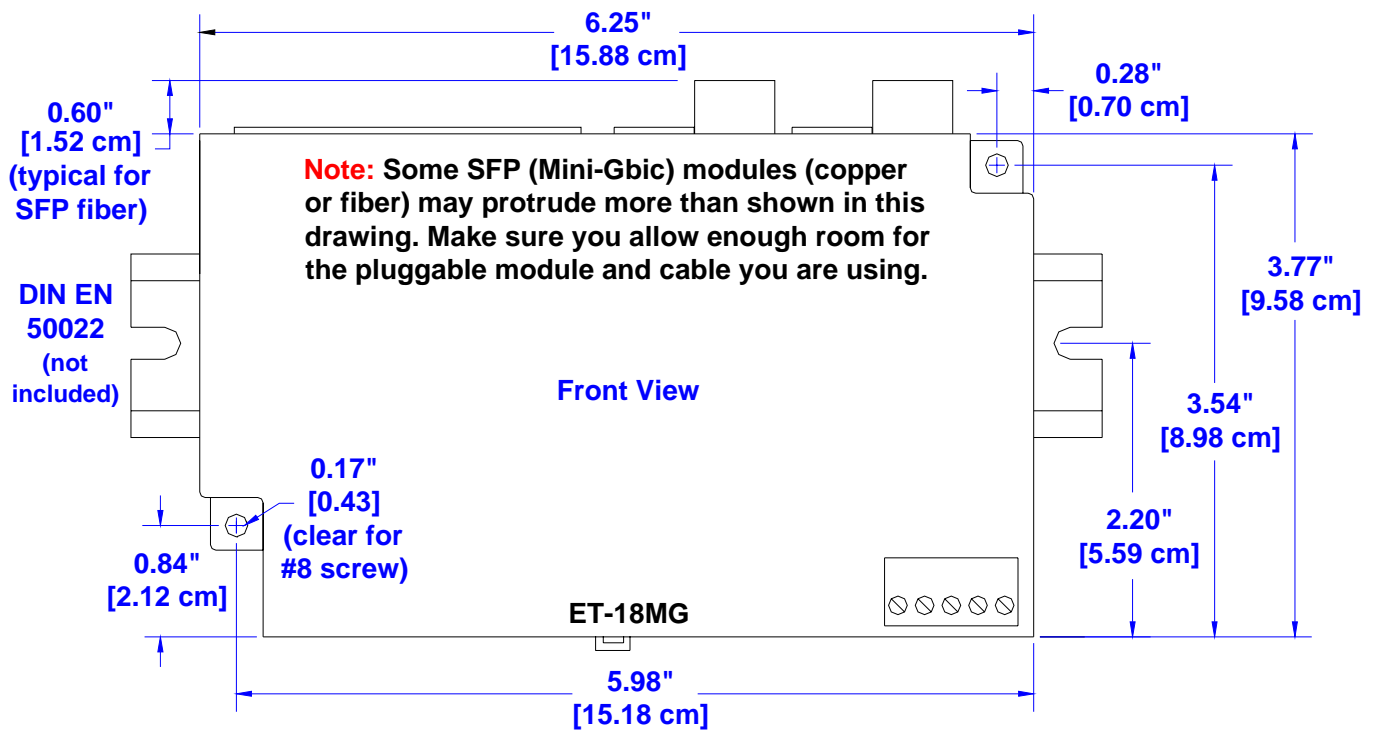

Mechanical Dimensions for 18-Port Models with Gigabit

Section 4

Power and I/O Wiring

Overview

The Managed Switches can be powered from the same DC source that is used to power your other devices. 10 to 30 VDC needs to be applied between the P1 terminal and the Minus terminal as shown below. The first screw terminal should be tied to panel or chassis ground. To reduce down time resulting from power loss, the Managed Switch can optionally be powered redundantly with a second power supply as shown below.

The Managed Switches also have an “OK” output that can be tied to a PLC input or other device to indicate when there is a power loss. When ON, this output will source the same voltage that is applied to the switches power terminals. See the wiring diagram below.

The switch with modem has a “To PLC” output and “From PLC” input. The “To PLC” output can be tied to a PLC input or other device to indicate when there is a valid phone connection. When ON, this output will source the same voltage that is applied to the switches power terminals. The “From PLC” input can be tied to a PLC output or other device to trigger a dial-out operation. The input voltage should be between 10 to 30 VDC. Refer to the software manual for operation details.

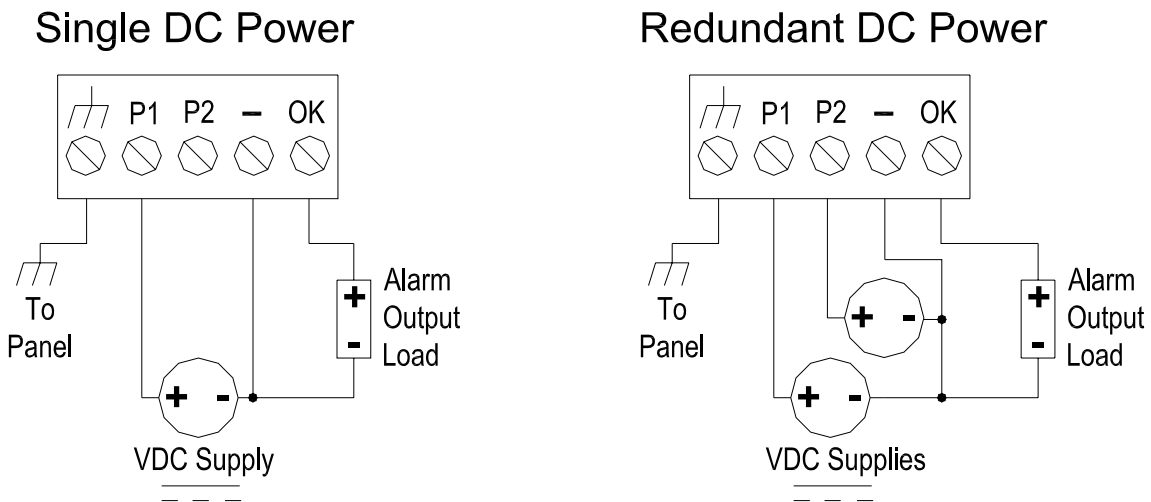

Power & Alarm Wiring for Managed Switch

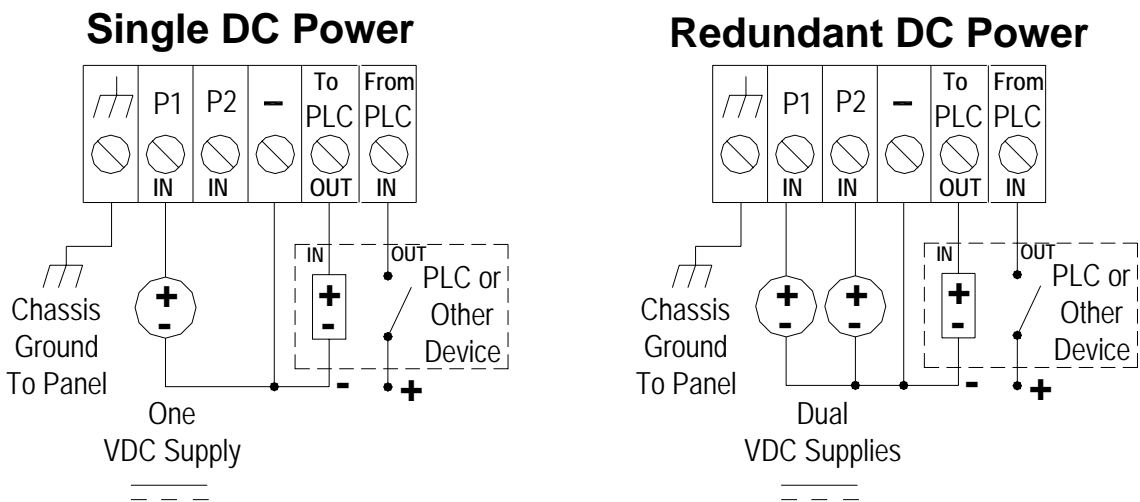

Power & I/O Wiring for Managed Switch with Modem

Screw Torque

When tightening the screws of the Managed Switch be careful to tighten to a max. of 3.48 lb-in.

Section 5

Communication Ports Wiring

Overview

The Managed Switches provides connections to standard Ethernet devices such as PLCs, Ethernet I/O, industrial computers and much more. Three types of communication ports may be found on these managed switches: Ethernet ports (RJ45 or fiber), management port (serial) or telephone port (switch with modem only).

RJ45 Ethernet Wiring

Use data-quality (not voice-quality) twisted pair cable rated category 5 (or better) with standard RJ45 connectors. For best performance use shielded cable. Straight through or crossover RJ45 cable can be used regardless of the device the switch is to be connected to as all these Managed Switches are capable of auto-mdi/mdix-crossover detection.

The RJ45 Ethernet port connector bodies on these products are metallic and are connected to the Chassis GND terminal. Therefore, shielded cables may be used to provide further protection. To prevent ground loops, the cable shield should be tied to the metal connector body at one end of the cable only. Electrical isolation is also provided on the Ethernet ports for increased reliability.

For Reference Only.
Either cable wiring will work!

Straight-thru Cable Wiring		Cross-over Cable Wiring	
Pin 1	Pin 1	Pin 1	Pin 3
Pin 2	Pin 2	Pin 2	Pin 6
Pin 3	Pin 3	Pin 3	Pin 1
Pin 6	Pin 6	Pin 6	Pin 2

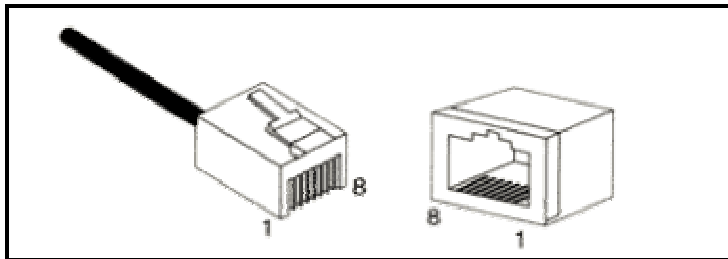

Ethernet Plug & Connector Pin Positions

RJ45 Cable Distance

The maximum cable length for 10/100/1000BaseT is typically 100 meters (328 ft.).

Ethernet Fiber Wiring Guidelines

The Managed Switches optionally have one or two pair of multimode or singlemode fiber ports. The maximum segment length is up to 120 km or more depending on the type of fiber optic transceiver installed in the switch. Refer to the technical specifications for details.

Each fiber optic port on the switch is comprised of a pair of SC, ST or LC style connectors. For each fiber port there is a transmit (TX) and receive (RX) signal. When making your fiber optic connections, make sure that the transmit (TX) port of the switch connects to the receive (RX) port of the other device, and the receive (RX) port of the switch connects to the transmit (TX) port of the other device. See images below.

Use standard fiber optic wiring techniques (not covered by this manual) to make your connections. The corresponding ACT/LNK LED will be ON solid when you have made a proper connection.

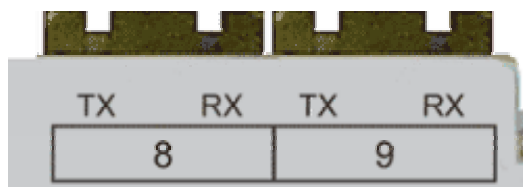

100BaseT Fiber Ports (SC Style)

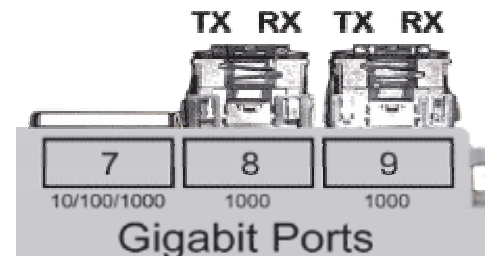

Gigabit Ports

Note: On the 10MG and 18MG, both Gigabit ports have a RJ45 (10/100/1000) and a SFP cage. For each of these ports only one connector can be used at a time.

Duplex Operation

The RJ45 ports will auto-sense for Full or Half duplex operation, while the fiber ports are configured for full duplex operation. Note: Fiber devices with half duplex settings should still communicate with the switch. If otherwise then contact your switch vendor.

Network Device Check

The Managed Switches are capable of supporting 10/100/1000BaseT and 100 or 1000BaseF. Make sure you connect the appropriate devices to each port.

Verifying Connectivity

After all Ethernet and/or fiber connections are made, check the LED's corresponding to the ports that each of the devices are connected to. Ensure that for each port that is in use, the LED is on or blinking. If a port LED is off, go back and check for connectivity problems between that port and the network device connected to that particular port. In addition, the color of the LED should indicate the speed for which your device is connected at (see prior section on LEDs).

Serial Port Wiring

An optional way to configure the switch is through the RJ45 console RS232 port. Use a DB9F to RJ45F adapter along with a RJ45 male to RJ45 male straight-thru-wired patch cable to make a connection between a com port on your PC (DB9 male) and the RS232 port of the Managed Switch (RJ45 female). Contact your switch vendor to purchase this as an accessory.

A typical DB9F to RJ45F adapter should be wired as follows:

Switch		Adapter	
RJ45F Pin #	Signal Name	Signal Name	DB9F Pin #
1	RI/DSR in	DTR out	4
2	DCD in	N/C	n/c
3	DTR out	DSR in	6
4	GND	GND	5
5	RXD in	TXD out	3
6	TXD out	RXD in	2
7	CTS in	RTS out	7
8	RTS out	CTS in	8



Telephone Wiring

This applies to the switch with an integrated modem only. Use standard telephone patch cables to connect your analog phone line(s) to the RJ-11 jacks as appropriate. The RJ-11 jack marked as "Phone" is provided to connect directly to a telephone (optional) and the other RJ-11 jack (marked as "Line") functions as the connection to the telephone network.



Lightning Danger: Do not work on equipment during periods of lightning activity.

Warning: Do not connect a telephone line into one of the Ethernet RJ45 connectors.

Section 6

Technical Specifications

Technical Specs

Here are the hardware technical specifications for the Managed Switches covered by this manual. Refer to the software user manual or datasheet for complete software specifications.

Copper RJ45 Ports: (10/100BaseT or 10/100/1000BaseT)	
10/100/1000BaseT ports	Shielded RJ45
Protocols supported	All standard IEEE 802.3
Ethernet compliancy	IEEE 802.3, 802.3u, 802.3x, 802.3z, 802.1p and more
Auto-crossover	Yes, allows you to use straight or cross wired cables
Auto-sensing operation	Full and half duplex
Auto-negotiating	10BaseT and 100BaseT and 1000BaseT as applicable
Auto-polarity	Yes, on the TD and RD pair
Flow control	Automatic
Ethernet isolation	1500 VRMS 1 minute
Plug and play	Yes
Cable requirements	Twisted pair (Cat. 5 or better) (shielded recommended)
Max. cable distance	100 meters
SC or ST Fiber Ports: (100BaseF multimode or singlemode)	
100BaseF ports	Up to 2
Fiber port mode	Multimode (mm) or Singlemode (sm)
Fiber port connector	Duplex SC or ST
Optimal fiber cable	62.5/125 μ m for mm; 9/125 μ m for sm
Center wavelength	1300 nm
TX output power	Contact your switch vendor
RX input sensitivity	Contact your switch vendor
Max. distance (full duplex) (see web for details)	4 km with mm; 20 km with sm, 70+ km with long haul sm
Half and full duplex	Software Configurable
Ethernet compliance	100BaseF
Eye safety	IEC 60825-1, Class 1; FDA 21 CFR 1040.10 and 1040.11
SFP Mini-Gbic SFP (pluggable) Ports: (many types available)	
Note: The last two ports on the Gigabit models are pluggable and accept many different types of pluggable SFP (Mini-Gbic) modules for Gigabit copper or fiber connections.	
Gigabit ports	Up to 2
Port types	Copper RJ45, fiber multimode, fiber singlemode, fiber long haul singlemode, fiber single strand, 1000BaseF (SX/LX/LH) modules
Fiber port connector	RJ45 for copper; LC typically for fiber (depends on module)
Optimal fiber cable	62.5/125 μ m for multimode (mm); 9/125 μ m for singlemode (sm)
Fiber wavelength	850 nm for mm; 1310 nm for sm; 1550 for long haul sm
TX output power	Contact your switch vendor
RX input sensitivity	Contact your switch vendor
Max. distance (full duplex)	Up to 120+ km with long haul singlemode modules
Half and full duplex	Software Configurable
Ethernet compliance	1000BaseT and 1000BaseF (SX/LX/LH)
Eye safety	IEC 60825-1, Class 1; FDA 21 CFR 1040.10 and 1040.11

Note: Additional fiber optic transceiver specifications are available. Also, other fiber transceivers may be available for special requirements such as longer distances, single strand or other special applications. **Contact your switch vendor for details.**

General Specifications:		
Ethernet switch type	Managed with 5, 9, 10, 16 or 18 Ethernet ports	
Latency for 10 Mbps ports	16 us + frame time (typical)	Varies on load and settings
Latency for 100 or 1000 ports	5 us + frame time (typical)	
Full or half duplex operation	Configurable	
“OK” Output	ON if P1 and P2 have power and switch software is running	
Voltage	Same as switch input voltage	
Maximum current output	0.5 Amp	
Management serial port	RS232 (TXD, RXD and GND), 9600, 8, N, 1 fixed	
Environmental	DIN rail or direct panel mounting	
Power input	Redundant Input Terminals	
Input power (typical - all ports active at 100 Mbps) (10 W maximum)	3.W (5-port model w/out fiber), 4 W (5-port model with 1 fiber), 5 W (5-port model with 2 fiber), 5 W (5-port model w/ modem), 7 W (9-port model w/out fiber), 8 W (9-port model with 1 fiber), 9 W (9-port model with 2 fiber)	5 W (10-port model w/out fiber), 7 W (10-port model w/ 2 fiber), 7 W (16-port model w/out fiber), 8 W (18-port model w/out fiber) 10 W (18-port model w/ 2 fiber)
Input voltage (all models)	10-30 VDC (continuous)	
Reverse power protection	Yes	
Transient protection	15,000 watts peak	
Spike protection	5,000 watts (10x for 10 uS)	
Extended protection	Models -4 & -5 of 9MS only	
Military surge protection	Exceeds MIL-STD-1275	
Maximum voltage surge	100V for 1 second	
Maximum voltage spike	5,000 watts (10x for 10 uS) or 250 volts (50x for 100 uS)	
Ethernet isolation	1500 VRMS 1 minute	
Operating temperature range	-40 to +75 °C	
Storage temperature range	-40 to +85 °C	
Humidity (non-condensing)	5 to 95% RH	
Vibration	IEC68-2-6	
Electrical safety		UL508/CSA C22, EN61010-1
EMI emissions		FCC part 15, ICES-003, EN55022
EMC immunity		IEC61326-1
Hazardous locations	UL1604, CSA C22.2/213 (Class 1, Div. 2), Cenelec EN50021 (Zone 2)	
Marine and off-shore tested	DNV (Det Norske Veritas)	
Eye safety (fiber models)	IEC60825-1, Class 1; FDA 21 CFR 1040.10 and 1040.11	
Packaging	IP30 protection (Lexan & aluminum case)	
Dimensions (L x W x H)	See mechanical diagrams for details	
Modem Specifications: (switch with modem only)		
Max. ISP to Modem speed	56 kbps (v.90)	
Compatibility	V.90,V.34,V.32bis,V.32,V.22bis,V.22,V.21	
Error Correction	V.42 (LAP or MNP)	
Data Compression	V.42bis	
Ringer Equivalent	.1B	
Line and phone Jack	RJ11	
Command set	AT and S register	
“To PLC” output	Yes, indicates modem connection status	
Power	Sourced from input power	
Max. current output	0.5 Amp	
“From PLC” input	10-30 VDC; 6.5 mA or less @ 24 VDC	
Telecom Ratings	FCC part 68; Industry Canada CS03-8; CTR21 (98/482/EC); ACA TS 001; ACA TS 002	

Section 7

Service Information

Service Information

We sincerely hope that you never experience a problem with any **SIXNET** product. If you do need service, call **SIXNET** at (518) 877-5173 and ask for Applications Engineering. A trained specialist will help you to quickly determine the source of the problem. Many problems are easily resolved with a single phone call. If it is necessary to return a unit to us, an RMA (Return Material Authorization) number will be given to you.

SIXNET tracks the flow of returned material with our RMA system to ensure speedy service. You must include this RMA number on the outside of the box so that your return can be processed immediately.

The applications engineer you are speaking with will fill out an RMA request for you. If the unit has a serial number, we will not need detailed financial information. Otherwise, be sure to have your original purchase order number and date purchased available.

We suggest that you give us a repair purchase order number in case the repair is not covered under our warranty. You will not be billed if the repair is covered under warranty.

Please supply us with as many details about the problem as you can. The information you supply will be written on the RMA form and supplied to the repair department before your unit arrives. This helps us to provide you with the best service, in the fastest manner. Normally, repairs are completed in two days. Sometimes difficult problems take a little longer to solve.

If you need a quicker turnaround, ship the unit to us by air freight. We give priority service to equipment that arrives by overnight delivery. Many repairs received by mid-morning (typical overnight delivery) can be finished the same day and returned immediately.

We apologize for any inconvenience that the need for repair may cause you. We hope that our rapid service meets your needs. If you have any suggestions to help us improve our service, please give us a call. We appreciate your ideas and will respond to them.

For Your Convenience:

Please fill in the following and keep this manual with your **SIXNET** system for future reference:

P.O. #: _____ Date Purchased: _____

Purchased From: _____

Product Support

To obtain support for **SIXNET** products:

On-line support: <http://www.get2support.com>

Order on-line: <http://www.sixnetstore.com>

Latest product info: <http://www.sixnetswitch.com>

Phone: +1 (518) 877-5173

Fax: +1 (518) 877-8346

E-mail: <mailto:support@sixnetswitch.com>

Mailing address: **SIXNET**, 331 Ushers Road, P.O. Box 767, Clifton Park, NY 12065