

ADVANCED KEYS

Smart Keyless Entry System

INSTALLATION GUIDE



Product Features:

- Smart Keyless Locking/Unlocking
- Compact Sized Smart Keys
- Dual-Antenna Setup
- Bypass Transponder RFID Cards
- Vehicle Anti-Theft Function
- Shock Sensor Alarm / Unlock
- Ignition Controlled Lock / Unlock
- Auto Vehicle Battery Power Saving
- Door-Not-Closed Reminder
- Smart Key Battery Low Reminder
- Locking-Delay Function
- Compatible with Push-Start Ignition
- Auto Window Closing / AUX Output

TABLE OF CONTENTS

Table Of Contents	2
Product Contents	2
Warning and Safety Information	3
Safety Precautions	3
Pre-installation Considerations	3
Connections	4
Controller Wiring Diagram	4
Main Harness Wire Descriptions	5
Access Harness Wire Descriptions	6
Installation	7
Installation Overview	7
Installation Note	7
Programmable Features	7
Antenna Installation	8
Frequent Asked Questions	9
Smart Key Programming Procedure	10
Closing Up	11
References Information	11
Specifications	11
Product Registration	11
Warranty	12
FCC And Canadian Compliance	12

PRODUCT CONTENTS

The following list of components are included in this system:

- | | |
|-------------------------------|------------------------------------|
| 1 – Control Unit | 1 – Bypass Antenna |
| 2 – Smart Key Fob | 2 – Bypass Transponder Card |
| 1 – Main Harness (8-Pin) | 1 – Shock Sensor |
| 1 – Accessory Harness (7-Pin) | 1 – Starter Disable Relay |
| 1 – Dual Colour LED Indicator | 1 – User Manual/Installation Guide |
| 1 – Front Antenna Coil | |
| 1 – Rear Antenna Coil | |

WARNING AND SAFETY INFORMATION

PRODUCT SAFETY AND LEGAL DISCLAIMER

- This product shall be installed by a certified technician therefore a certain level of competence and knowledge are therefore assumed when reading this guide.
- This guide is provided as a GENERAL installation instructions and vehicle subjected to installation maybe different.
- This product is designed based on vehicle regulatory standard. Please observe your local public road traffic law and regulations prior to installation.
- Exercise due-diligence when installing this product. The manufacturer and distributors of this product will not accept any vehicle damage or personal injury resulting from the installation of this product. Installation of this product is acceptance of this statement and releases the manufacturer/distributors of this product from any direct or indirect liabilities.
- Once installation is complete, please return this guide along with other documentations included in this product back to the customer for future reference. The manufacturer/distributors of this product does not guarantee this particular version will be available at a later date.

PRE-INSTALLATION CONSIDERATIONS

- Carefully read and understand the User Manual, Installation Guide and Electrical Service Information for the subjected vehicle before begin work.
- Install in a well-lit, dry, covered area away from the elements and keep at least one window open at all time during installation. Do not leave key inside ignition switch and /or detection range. Prepare all tools required for the installation. Special tools maybe necessary depending on vehicle.
- Verify the vehicle has proper grounding and does not have any outstanding electrical/functional issue prior to installation.
- To avoid short circuit, it is recommended to pull-out related fuses before installation and put them back when installation is complete.
- Only locate necessary wires related to the installation (most required wiring are under driver dash/kick panel areas) and connect to the unit according to the wiring diagram. Use a Multimeter to verify and confirm wire's function, polarity before connecting or disconnecting. We strictly prohibit testing or modifying the vehicle's ECU, airbag and ABS systems.
- Begin function tests on the system after verifying and ensuring all wires have been connected correctly and insulated properly.



DO NOT power up the module before it is properly grounded. Should the unit be powered before being grounded, serious damage to internal components could occur.

CONNECTIONS

CONTROLLER WIRING DIAGRAM

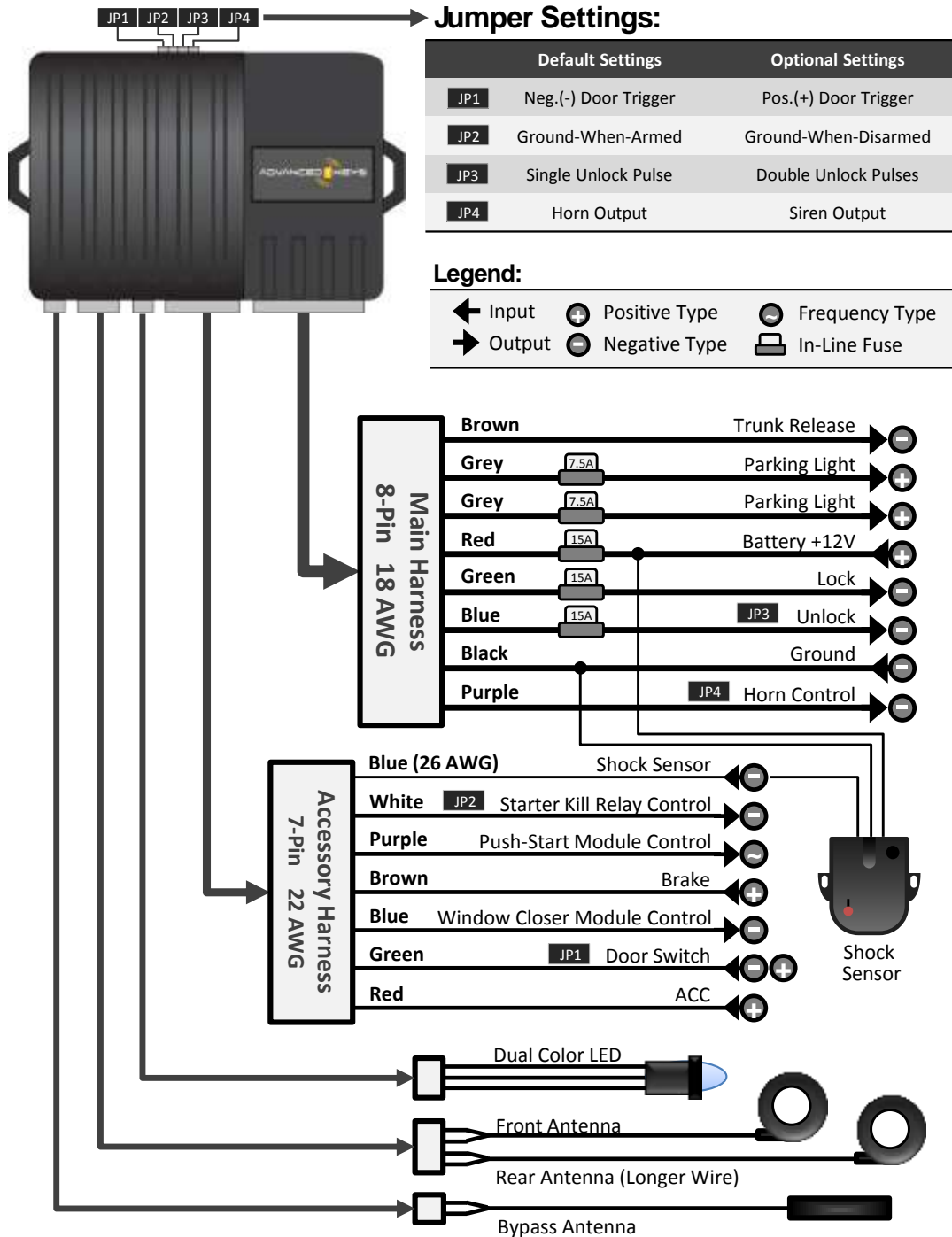

WARNING: Manufacturer/Distributors of this product will not be responsible for any electrical damage resulting from improper installation of this product, be that either damage to the vehicle itself or to the device. This device must be installed by a certified technician for this guide has been written for properly trained technicians; a certain level of skill & knowledge is therefore assumed. Review this installation guide and vehicle's service manuals before install.

MAIN HARNESS WIRING DESCRIPTIONS

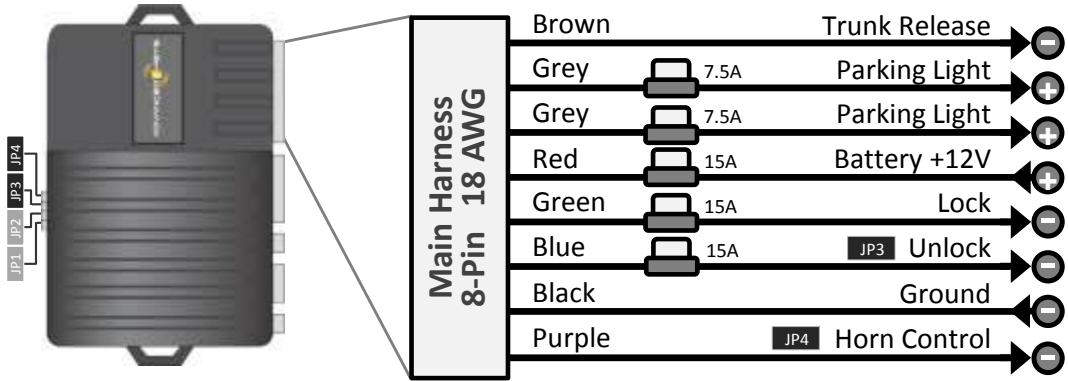

Wiring Description:

Brown	OUTPUT	—	500mA	Trunk Release
--------------	--------	---	-------	----------------------

Connect to the negative side of the trunk release trigger. This output will provide 1 second pulse when UNLOCK button is pressed for 2 seconds. (This function is disabled when ACC input is ON)

Grey	OUTPUT	+	7.5A	2x Parking Light
-------------	--------	---	------	-------------------------

Connect to the positive side of left/right parking lights or the hazard light switch for same effect.

Red	INPUT	+	15A	Battery +12V
------------	-------	---	-----	---------------------

Connect to a +12v source. Ensure that the OEM source wire used is fused for more than 15A.

Note: When no suitable +12V source available (where current capacity is less than 15A) use vehicle's interior fuse junction box or route directly from battery B+ connection.

Green	OUTPUT	—	15A	Lock
--------------	--------	---	-----	-------------

Connect this output directly to the negative-triggered door **lock** signal wire.

Blue	OUTPUT	—	15A	Unlock JP3
-------------	--------	---	-----	--------------------------

Connect this output directly to a negative-triggered door **unlock** signal wire.

Note: This system outputs a single unlock pulse by default. Jumper (**JP3**) provides a double unlock pulses output option for vehicles that require a two consecutive unlock-pulse to unlock/disarm or to bypass the Driver Door Priority Unlock function to unlock all doors.

Black	INPUT	—	15A	Ground
--------------	-------	---	-----	---------------

Connected to a bare, unpainted metal part of the vehicle chassis. It is recommended to use a factory ground point bolt rather than a self-tapping screw. Screws tend to loosen or rusted over time and leading to erratic electrical problems.

Purple	OUTPUT	—	500mA	Horn Control JP4
---------------	--------	---	-------	--------------------------------

Connect to the negative side of horn for audio notification.

Note: This system is programmed for muted Lock/Unlock operation by default. If audio notification is desired for arming and disarming; connect Horn Control output to a siren* and change the jumper setting (**JP4**) to Siren Output option (Refer to Horn or Siren Mode in Programmable Features).

Note: If siren control is a positive type or require more than 500mA to operate; add a relay according to the diagram on the right to convert output to a positive type.

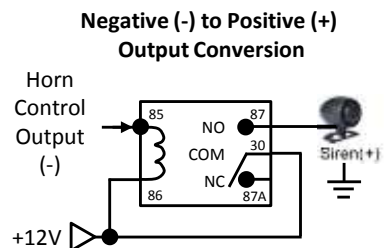

*Siren not included

ACCESSORY HARNESS WIRING DESCRIPTIONS

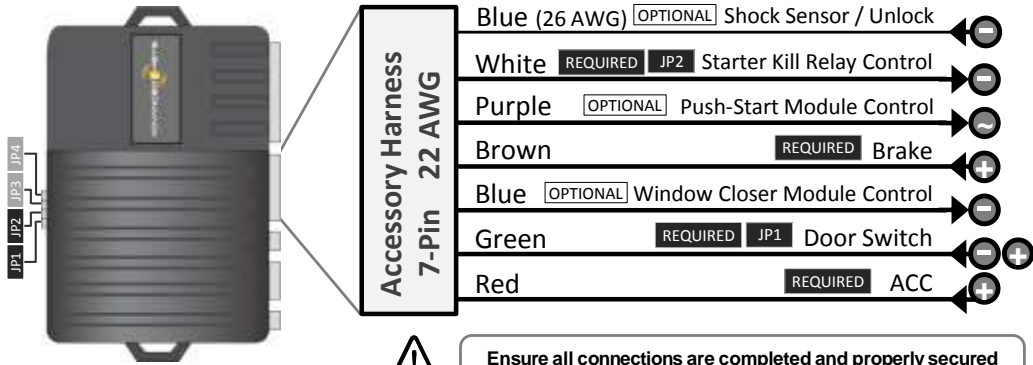

Ensure all connections are completed and properly secured prior to connecting the wire harnesses to the module.

Wiring Description:

Blue	INPUT	-		(26 AWG) Shock Sensor / Unlock Input	OPTIONAL
-------------	-------	---	--	---	----------

Connect to the optional Shock Sensor or to a manual unlock trigger input. (See Programmable Features)

White	OUTPUT	-	500mA	Starter Kill Relay Control	JP2 OPTIONAL
--------------	--------	---	-------	-----------------------------------	--------------

(Starter Kill Relay is not required if installed with AK-PSB05)
Depending on jumper (JP2) selection this output can be used for:

Starter Kill Relay Control (Default) – Also known as Ground-When-Armed. While armed (Smart Key not detected or LOCK button pressed) this output provide a GND signal to disable the starter circuit only when alarm is triggered. Connect the Starter Kill Relay according to the wiring diagram on the right.

Ground-When-Disarmed – Provides a GND signal while disarmed. (Smart Key is detected or UNLOCK button pressed) This output can be used as an enable signal to an immobilizer bypass or known as Ground-When-Running. Alternatively this output can connect to any system that requires an input signal when a Smart Key is sensed.

Starter Kill Relay (Included)

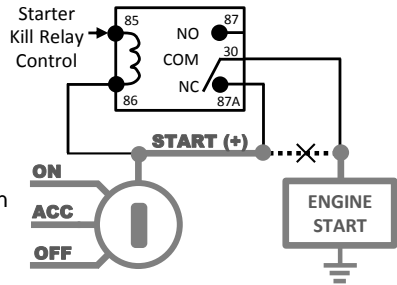

Purple	OUTPUT	~	100mA	Push-Start Module Control	OPTIONAL
---------------	--------	---	-------	----------------------------------	----------

Connect to the “Controller Enable Input” on the optional Engine Push-Start Ignition Controller. This output provides an encrypted signal to the Engine Push-Start Ignition controller only when system sense a valid Smart Key or disarmed via the UNLOCK button or from the Bypass Transponder Card.

Brown	INPUT	+		Brake	REQUIRED
--------------	-------	---	--	--------------	----------

Connect to the brake pedal switch that output +12v when brake is applied, GND or float when released.
Note: This input is required for Smart Key programming and Ignition-Controlled Lock function.

Blue	OUTPUT	-	100mA	Window Closer Module Control / AUX	OPTIONAL
-------------	--------	---	-------	---	----------

Connect to the optional Auto Window Closer Module trigger input. Alternately it can be used as a remote activated auxiliary output, see more on Programmable Features section on configure this auxiliary output.

Green	INPUT	-		Door Switch	JP1 REQUIRED
--------------	-------	---	--	--------------------	--------------

Connect to vehicle’s negative-triggered “door open” signal wire directly. Change jumper (JP1) to Positive Door Trigger if door switch is a positive-triggered type.

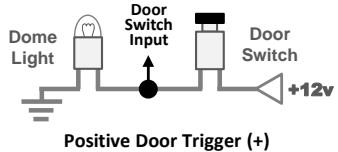
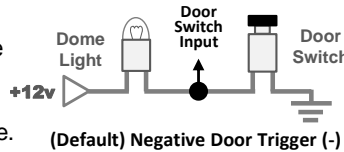

Red	INPUT	+		ACC	REQUIRED
------------	-------	---	--	------------	----------

****Required for System Operation**** This input must be connected to a +12v source when vehicle is running. **Note:** With this input active, controller will stop search for the Smart Keys to conserve key’s battery and avoid unintended lock actuation while the vehicle is running.

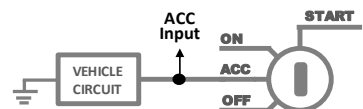

INSTALLATION

INSTALLATION OVERVIEW

Use following steps as a guide to install this system:

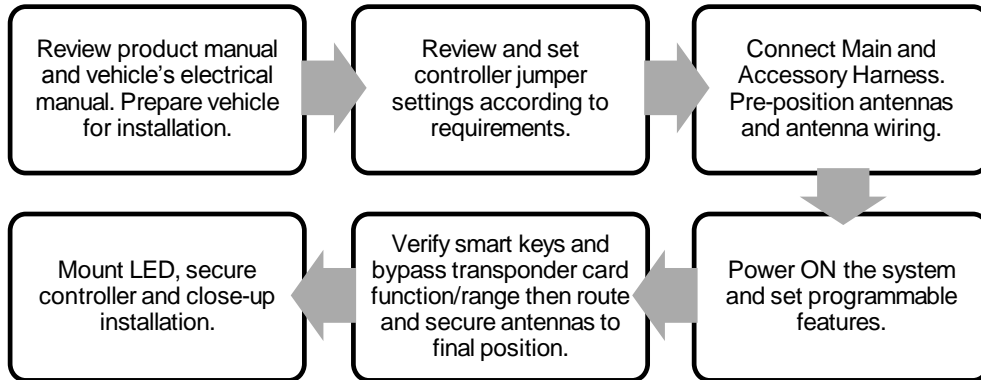

INSTALLATION NOTES

- For vehicles equipped with factory or aftermarket alarm/remote start, it is possible to install this system without the anti-theft alarm and remote start functions. (Refer to User Manual on disabling Alarm Function) Connect only **Battery, Ground, Lock, Unlock, ACC, Brake, Door Switch** and **Antennas** for basic Smart Keyless Entry function only.
- Ensure the **ACC** input is properly connected. It is required for remote-start function and to conserve the Smart Key's battery while vehicle is running. **Avoid** leaving the Smart Key inside the detection range for extended periods of time, this will shorten Smart Key's battery life as authentication stays constant between smart key and controller when ignition is off.
- It is highly recommended to connect the **Door Switch** input to the vehicle. This input is required for adjust user programmable functions and system will have a better remote sensing performance when it aware of the door status.

PROGRAMMABLE FEATURES

The following features can be adjusted according to customer's requirements:

Horn or Siren Mode

Under default JP4 "Horn Output" state; system will stay muted when locking and unlocking. Horn output will only sound in alarming and in programing modes. If the customer desires audio chirp notifications for vehicle's arming status, connect a siren to the horn output (see Wiring Description) and change JP4 to "Siren Output" setting. Siren and Parking Lights outputs behave as following:

	Horn Output	Siren Output	Parking Light
Unlock	-	2 x	2 x
Lock	-	1 x	1 x
Remote Start	-	1 x	1 x

PROGRAMMABLE FEATURES (CONT.)

Ignition-Controlled Door Lock

Enabled by default and controlled by Brake input, this function will provide:

- Auto Door **Locking** when ACC is turned ON while brake is applied.
- Auto Door **Re-Locking** when brake applied after door opened-then-closed.
- Auto Door **Unlocking** when ACC is OFF.

To **disable/enable** Ignition-Controlled Door Lock feature: Disconnect the Main harness (powering OFF the controller) then press and hold the brake pedal (apply +12v to Brake input) then reconnect the Main harness (powering ON the controller). Horn output will sound 2x if this feature is disabled or 1x if enabled.

Shock Sensor Function

Optional Dual-Stage Shock Sensor can be installed to provide additional security. (See User Manual for operation) Install the shock sensor near the center of the vehicle to sense vibrations from both the front and the back. Peel the adhesive and attach it to the vehicle's chassis (metal) surface. Test the shock sensor's sensitivity by applying light impact from all sides of the vehicle, adjust if necessary. Keep in mind that increased sensitivity would yield more false alarms.

The Shock Sensor Input can be programmed (See User Manual) to accept a Ground signal that triggers Door Unlock function while the Smart Key remote is in the range:

- User have the option to set the system to unlock doors only when the shock sensor is triggered. This is useful for vehicle with shaved door handles or for user that prefer manually unlocking doors by a slight "tap/knock" on the driver door. To use this function, set shock sensor sensitivity to max and mount it close to the trigger area where user might be "tap/knock" on.
- Alternatively, connect the Shock Sensor/Unlock Input to an external Ground trigger switch that is mounted on the door handle to activate Unlock manually.

Auxiliary Output (Via Remote Start Button)

If Smart Key system is a stand-alone installation (without Push-Start) or the remote start function is not required, the **Blue (22AWG) "Window Closer Module Control"** output can be programmed as an auxiliary output (See User Manual). Press-and-hold the Remote Start Button will produce a 1 second (-)negative pulse for triggering an external device.

Note: Once in AUX mode, Auto Windows Closer will not function automatically when locking/arming.

ANTENNAS INSTALLATION

Antennas should be mounted on a **Non-Enclosed** and **Non-Metallic** material such as clear glass or plastic trim panels. Recommended placements for the Front-Antenna is on the top-left corner of the front windshield and bottom-left corner of the rear windshield for the Rear-Antenna. The Bypass-Antenna can be placed around the edge of the front windshield so it can sense the Bypass Transponder Card within one inch away from outside of the vehicle. Do not place antenna in locations that will be shield by metallic material.

Test for coverage and range after installation to determine the optimal locations for the antennas. You may adjust antenna positions to other possible placement locations as illustrated in the diagram next page. Use double sided tape to secure antennas after final positions are confirmed.

ANTENNAS INSTALLATION (CONT.)

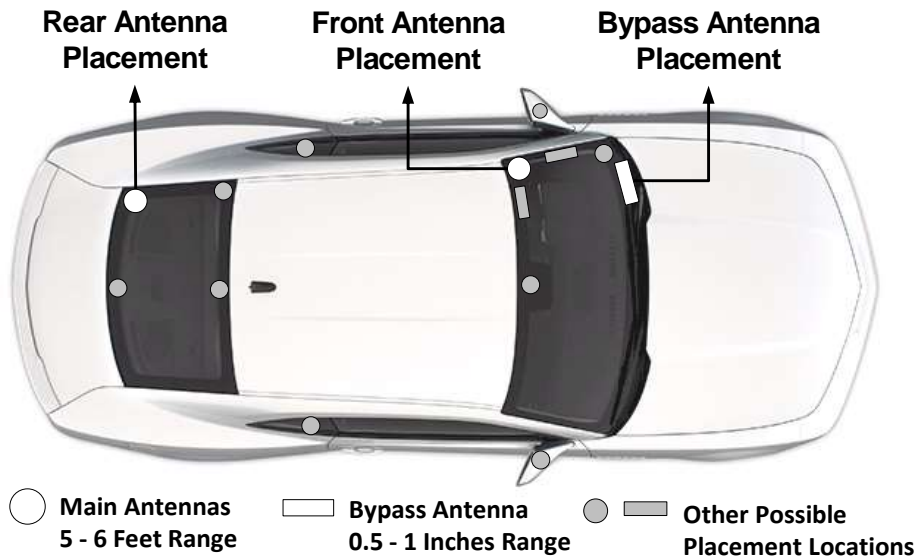

Antenna needs to be positioned away from any type of metallic material to achieve the best reception in all directions. Avoid strain/pull on antenna wiring and do not bend or overlap Main antenna with Bypass antenna.

FAQ

Why is key detection not working or the range is very sort?

Verify antenna position: Antenna may be on or close to metallic material, change position to verify range sensitivity. Check antenna wiring, do not pull on the antenna wires, make sure connectors are firmly seated. If remote failed to work both in proximity and manually press the buttons, follow key programming procedure to relearn all keys.

What does each LED color status mean?

See User Manual for more information on LED status detail.

How to install this system without the alarm function?

See User Manual for more information on disable alarm function.

How to enable/disable automatic door locking/unlocking function?

Please follow "Ignition-Controlled Door Lock" under the programmable features section to enable/disable this function.

How does Remote Start button on the Smart Key remote work?

Remote Start function require installing the optional Advanced Keys Push-Start System (AK-PSB05). Press the remote start button will send a remote start signal to the Push-Start Module via the Push-Start Module Control output. Please refer to Push-Start Installation manual for more info on remote start the vehicle.

KEY PROGRAMMING PROCEDURE

If required, use following procedures to pair a new set of Smart Key and/or Bypass Transponder Cards. Both sets of Smart Keys or the Bypass Transponder Cards must be present and accessible during programming.

Enter Programming Mode

Disarm the system with a valid Smart Key or Bypass Transponder Card.

With Ignition Key – Turn the Ignition Key to the ACC position. After few seconds switch the Ignition Key to OFF position and immediately back to ACC position for five times or as following: OFF–ACC–OFF–ACC–OFF–ACC–OFF–ACC–OFF–ACC. Keep the Ignition Key in ACC position at the fifth time and the horn will sound twice.

With Push-Start Button – Cycle ignition five times by press the Push Button OFF to ACC state first then after a few seconds quickly toggle the Push-Start button as follow: ON–OFF–ACC–ON–OFF–ACC–ON–OFF–ACC–ON–OFF–ACC–ON–OFF–ACC.

Note: Switch Ignition to OFF at any time will exit the programming mode with horn sound three times

Smart Key(s) Programming

1. After enter the Smart Key programming mode, LED indicator turns **RED**. You have a 30-second window to program. If you do not wish to program Smart Keys, press the brake pedal once to skip to Bypass Transponder Cards programming (Horn will sound once to confirm)
2. Press and hold the LOCK button on the first Smart Key until horn sound once.
3. Press and hold the LOCK button on the second Smart Key until horn sound once.
4. Smart Keys programming is now completed. System will automatically enter Bypass Transponder Cards programming mode.

Bypass Transponder Cards Programming

1. After enter the Bypass Transponder Card programming mode, LED indicator turns **BLUE**. You have a 12-second window to program. To skip Bypass Transponder Cards programming, press the brake pedal once will end the programming mode with horn sound five(5) times.
2. Hold first Bypass Transponder Card against the reading field of the Backup Antenna until the horn sound once.
3. Repeat for the second Bypass Transponder Card until the horn sound five(5) times to indicate key programming has been successfully completed.

Note: Only one Bypass Transponder Card should be present in the reading field at a time. The sensing range for the Bypass Antenna is under an inch.

Horn Sound Summary Table

Number of Horn Sound	Mode Description
1 x	Remote / Key Registered
2 x	Entered Programming mode
3 x	Programming failed
5 x	Programming successful

CLOSING UP

- Connecting the wire harnesses and power ON the controller, check and confirm system operations (Refer to User Manual) then verify functions of the vehicle are in working order.
- Make sure all wiring connection are insulated properly. Place and secure control units to locations inside trim panels and bundle all loose wiring. Put back all trim panels
- When mounting the controller unit in the vehicle, consider the location carefully. You should make sure that you avoid any location where the controller is exposed to moisture, extreme heat or interfere with moving parts on the vehicle which hampers driving.
- Explain all functions related to the end-user of this system.

REFERENCES INFORMATION

PRODUCT SPECIFICATIONS

Controller operating voltage range: 10 VDC – 16 VDC
 Controller Stand by power: ≤ 30mA @ 12 VDC
 Avg. controller operating power: ≤ 80mA@12VDC
 Devices operating temperature range: -25°C – +85°C
 Transmitter operating voltage range: 2 VDC – 4 VDC
 Transmitter Stand by power: ≤ 7 μA @ 3 VDC
 HF operation frequency and range: 433.92MHz @ 25 - 30 Meters
 LF operation frequency and range: 134.2 KHz @ 1.5 - 2 Meters
 Smart Key Fob Dimensions: 65mmL x 44mmW x 6mmH
 Base Controller Dimensions: 115mmL x 90mmW x 30mmH

PRODUCT REGISTRATION

Installer of this system is requested to fill out the following information as a proof of installation to the end-user of this system. For manufacture warranty to take immediate effect please request the end-user to update the following information at: <http://www.advancedkeys.com/registration.htm>

Company / Installer Name:		Phone Number:
Installer Address:		Date of Installation:
Vehicle Manufacture:	Model:	Year:
Front Antenna Location:	Rear Antenna Location:	Bypass Antenna Location:
Interface/Bypass Module Used: YES <input type="checkbox"/> NO <input type="checkbox"/>		All Smart Keys and Bypass Cards Working: YES <input type="checkbox"/> NO <input type="checkbox"/>
If YES specify bypass make/model:		Push-Start Module Installed: YES <input type="checkbox"/> NO <input type="checkbox"/>
		Antenna Mounted on Windshields: YES <input type="checkbox"/> NO <input type="checkbox"/>
		Reviewed Product Operation with End-User: YES <input type="checkbox"/> NO <input type="checkbox"/>

Additional Comments: