

SprayTECH[®]

BUILT TO WORK AS HARD AS YOU™

Diaphragm Pumps

1150

Piston Pumps

EP2105

EP2205

EP2300

EP2300se

EP2400

EP2510

GP2605

GP2905

HVLP

CS5100

CS8100

CS9100

Maxum II Gun

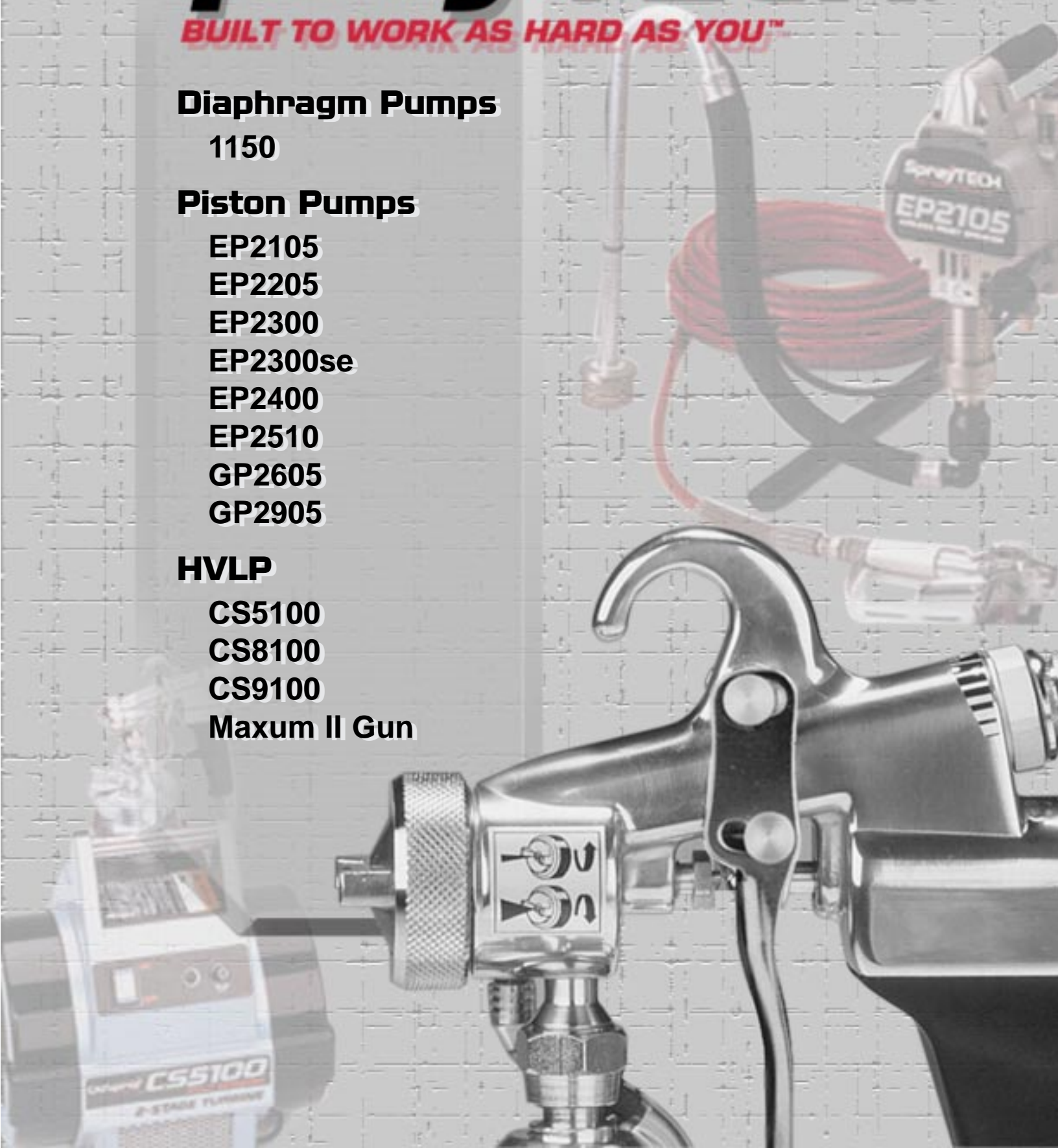

ED1150^{Plus} *Airless Sprayer*

Owner's Manual

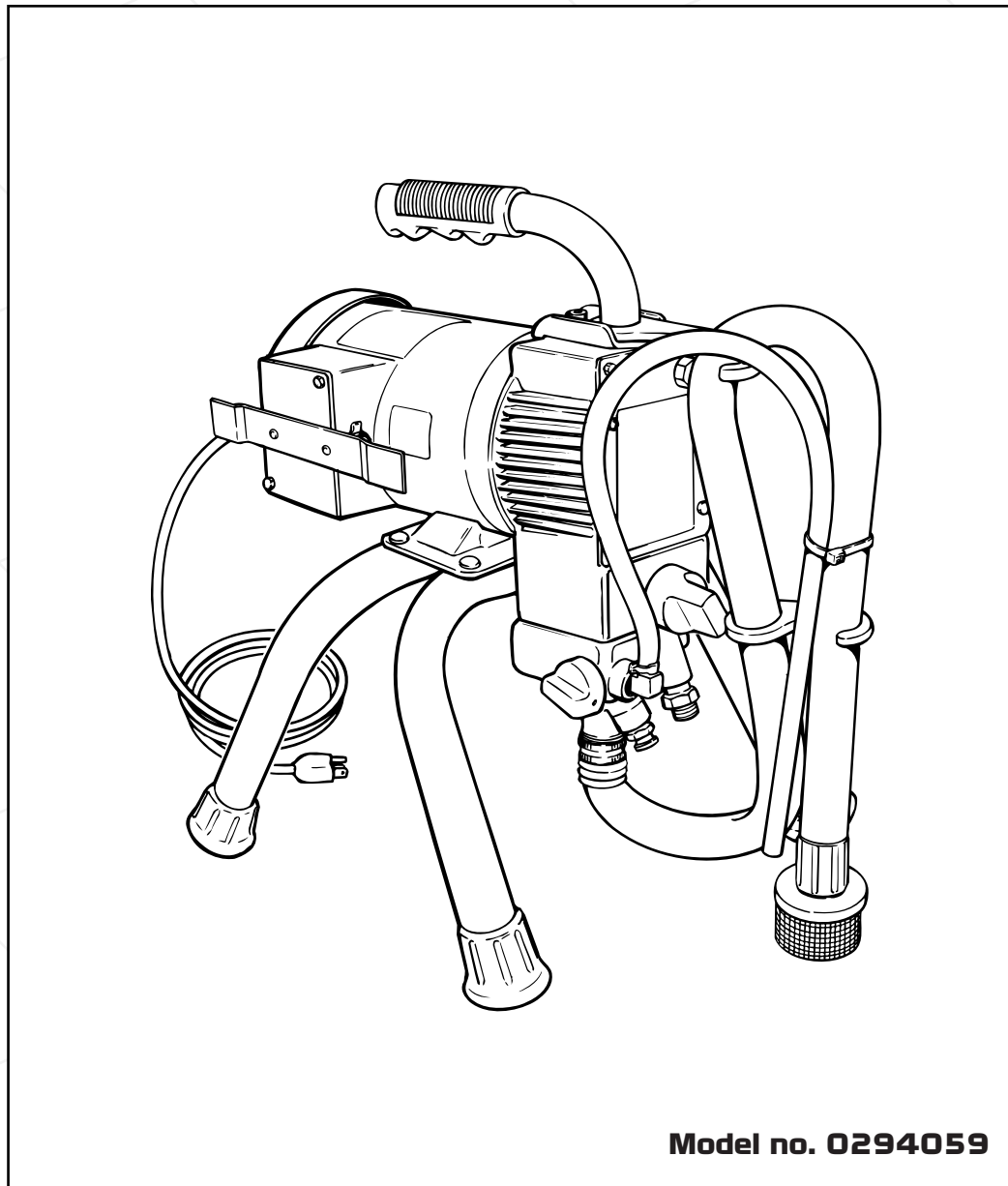

SprayTECH.
BUILT TO WORK AS HARD AS YOU™

Form no. 0294968C
© 1996 Wagner Spray Tech. All rights reserved.

CAUTION

THIS UNIT IS PROVIDED WITH A THERMALLY PROTECTED AUTOMATIC RESET. IF AN OVERLOAD OCCURS THE THERMALLY PROTECTED AUTOMATIC RESET DISCONNECTS THE MOTOR FROM THE POWER SUPPLY.

- Motor will restart without warning when protector automatically resets.
- Always disconnect motor from power supply before working on equipment.
- When thermally protected automatic reset disconnects the motor from the power supply, relieve pressure by turning priming valve to “prime”  .
- Turn ON-OFF switch to OFF.

CAUTION: THE CAUSE OF THE OVERLOAD SHOULD BE CORRECTED BEFORE RESTARTING.

CAUTION

Be sure to read, understand and observe all safety precautions and warnings. See pages 3 thru 6.

Read product labels—follow manufacturer’s recommendations

All procedures and recommendations presented in this manual are based on information which SprayTECH believes to be reliable. However, such procedures and recommendations are to be implemented and used by persons reading this manual at their own discretion and risk.

Label directions, procedures and precautions set forth by the manufacturers of finishing products are to be considered the best source of information on those products. No attempt has been made in this manual to provide complete data on all the various materials which may be used in your airless sprayer.

Application procedures are presented here as suggestions only, and are not to be construed as representations or warranties as to safety, performance, results or fitness for any intended use of the various types of products mentioned.

BEFORE YOU CALL

Have the following information available:

Model # _____

Serial # _____

Purchase Date _____

SAFETY PRECAUTIONS

This manual contains information which must be read and understood before using the equipment. When you come to an area which has one of the following symbols, pay particular attention and make certain to heed the safeguard.



Important safety information indicates a hazard which may cause serious injury or loss of life.



Important information that tells how to prevent damage to equipment or how to avoid causes of minor injuries.

Note: Gives important information which should be given special attention.

IMPORTANT EXTENSION CORD SELECTION

If an extension cord is used, make sure it is of the three-conductor type with NEMA connectors so a continuous grounding circuit is provided from tool to power circuit receptacle. Also, be sure that the conductor size is large enough to prevent excessive voltage drop which will cause loss of power. A table of recommended extension cord sizes will be found below.

For nameplate ampere ratings which are between those given, use the extension cord recommended for the **NEXT HIGHER** ampere rating.

If an extension cord is to be used outdoors it must be marked with the suffix W-A following the cord type designation. For example — SJTW-A to indicate it is acceptable for outdoor use.

RECOMMENDED EXTENSION CORD SIZES FROM SERVICE ENTRANCE TO PUMP MOTOR.

NAMEPLATE AMPERE RATING

Cord Lgth.	0 to 5	6	7	8	9	10	11	12	13	14	15	16	17	18	19	20
25Ft.	18	18	18	18	18	18	16	16	16	14	14	14	14	14	12	12
50Ft.	18	18	18	18	18	18	16	16	16	14	14	14	14	14	12	12
25Ft.	18	18	18	18	18	18	16	16	16	14	14	14	14	14	12	12
100Ft.	18	18	18	16	16	16	16	16	14	14	14	14	14	14	12	12
125Ft.	18	18	16	16	16	14	14	14	14	14	14	12	12	12	12	12
150Ft.	18	16	16	16	14	14	14	14	14	12	12	12	12	12	12	12



HAZARD

PREVENTION

Injection Injury - A high pressure stream of paint produced by this equipment can pierce the skin and underlying tissues, leading to serious injury and possible amputation.

- Maximum operating range of the gun - **3000 PSI fluid pressure.**
- **NEVER** aim the gun at any part of the body.
- **NEVER** allow any part of the body to come in contact with the fluid stream. **DO NOT** come in contact with a fluid stream created by a leak in the fluid hose.
- **NEVER** put hand in front of the gun. Gloves will not provide protection against an injection injury.
- **ALWAYS** lock the gun trigger, shut fluid pump off and release all pressure before servicing, cleaning tip guard, changing tips, or leaving unattended. Simply turning off the electrical power will not release pressure in the system. The Prime Spray Valve must be turned to the  position to relieve the pressure.
- **ALWAYS** have the tip guard in place while spraying. The tip guard provides some protection against injection injuries but is mainly a warning device.
- **ALWAYS** remove spray tip before flushing or cleaning the system.
- Paint hose can develop leaks from wear, kinking, abuse, etc. A leak is capable of injecting material into the skin. The paint hose should be inspected before each use.
- **NEVER** use a spray gun which does not have a trigger lock or trigger guard in place and in working order.
- All accessories must be rated at or above 3000 P.S.I. (Includes spray tips, guns, extensions, and hose).
- In case of skin injection see physician immediately.

DO NOT TREAT AS A SIMPLE CUT! Injection can lead to amputation. See a physician immediately.

NOTE TO PHYSICIAN: Injection into the skin is a traumatic injury. It is important to treat the injury surgically as soon as possible. **DO NOT** delay treatment to research toxicity. Toxicity is a concern with some coatings injected directly into the blood stream. Consultation with a plastic surgeon or reconstructive hand surgeon may be advisable.



HAZARD

PREVENTION

Explosion or fire - Solvent and paint fumes can explode or ignite causing property damage and/or severe injury.

- Exhaust and fresh air introduction must be provided to keep the air within the spray area free from accumulation of flammable vapors.
- Avoid all ignition sources such as static electricity sparks open flames such as pilot lights, hot objects such as cigarettes, and sparks from connecting and disconnecting power cords and working light switches.
- Fire extinguishing equipment must be present and in working order.
- Keep the pump away from spray area to avoid solvent and paint fumes. The pump contains arcing parts which emit sparks.
- High velocity flow of material through equipment may develop static electricity. The equipment being used, and objects in and around the spray area, must be properly grounded to prevent static discharge and sparks.
- Use only conductive or grounded high pressure fluid hoses for airless applications. Be sure that gun is grounded through hose connections.
- Power cord must be connected to a grounded circuit.
- Follow the material and solvent manufacturer's safety precautions and warnings.
- WHEN FLUSHING EQUIPMENT use lowest possible pressure.



HAZARD

PREVENTION

Explosion hazard incompatible materials - May cause property damage or severe injury.

- Halogenated hydrocarbon solvents such as methylene chloride and 1,1,1 - Trichlorethane are not compatible with aluminum and may cause an explosion. If unsure of a material's compatibility with aluminum, contact your coatings supplier.
- Some spray guns and accessories cannot be used with halogenated hydrocarbon solvents. Be certain of compatibility before use with halogenated hydrocarbon solvents.
- The SprayTECH ED1150 pump is **not** compatible for use with halogenated hydrocarbon solvents. The SprayTECH G-05, G-09, and G-10 guns must **NOT** be used with halogenated hydrocarbon solvents.

Hazardous vapors - Paints, solvents, insecticides, and other materials may be harmful if inhaled causing severe nausea, fainting, or poisoning.

- Use a respirator or mask whenever there is a chance that vapors may be inhaled. Read all instructions with the mask to insure that it will provide the necessary protection against the inhalation of harmful vapors.

General - May cause property damage or severe injury.

- Read all instructions and safety precautions before operating.
- Comply with all appropriate local, state and national codes governing ventilation, fire prevention and operation.
- The United States Government Safety Standards have been adopted under Occupational Safety and Health Act. These standards, particularly the General Standards, Part 1910 and construction Standard, Part 1926, should be consulted.
- This high pressure airless pump is designed to be used with authorized SprayTECH parts only. When using this pump with parts that do not comply with the minimum specifications and safety devices of the pump manufacturer, the user assumes all risks and liabilities.
- Before each use, check all hoses for cuts, leaks, abrasion or bulging of cover or damage or movement of couplings. If any of these conditions exist, replace the hose immediately. Never repair a paint hose. Replace it with another grounded hose.
- All hoses, swivels, guns, and accessories used with this unit must be pressure rated at or above 3000 PSI.

GENERAL DESCRIPTION

Be sure to read the IMPORTANT SAFETY INFORMATION on pages 3 thru 6 before using this sprayer.

Your SprayTECH sprayer is a powerful, easy to operate and easy to service machine. Since it operates on the airless principle, no air compressor is needed.

Power is supplied by a 3/4 horsepower, TEFC electric motor. The flow rate is 0 to .50 gallons a minute. The pressure is adjustable from 0 to 3000 pounds per square inch.

COMPONENT FUNCTIONS

See Figure 1 for component locations.

Power for the sprayer is supplied by a 3/4 horsepower, TEFC electric motor (see Figure 1). It is located at the rear of the sprayer and is connected to the hydraulic pump. The motor is furnished with a 3-wire electric cord. The third wire (ground) should never be cut off. Any extension cords used

must also be 3-wire and 3-wire plug that will plug into a 3-wire grounded electrical outlet. Do not use 2-wire extension cords. Shorter extension cords will assure maximum electrical power for proper operation, use more paint hose, not more extension cords. **Refer to page 3 for extension cord selection.**

Cords and extension cords should be protected from vehicle traffic and sharp cutting edges or objects. Any worn or damaged cords should be replaced promptly.

The motor has an automatic overload protective switch. This switch disconnects the motor from electrical supply if overload occurs. The motor can be started again after 5 minutes. The cause of the overload should be corrected before restarting.

The motor should always be kept clean and dry. Paint acts as an insulator. Therefore, too much paint on the motor will cause it to overheat.

ON-OFF SWITCH

The ON-OFF switch is located on the side of the electric motor (see Figure 1).

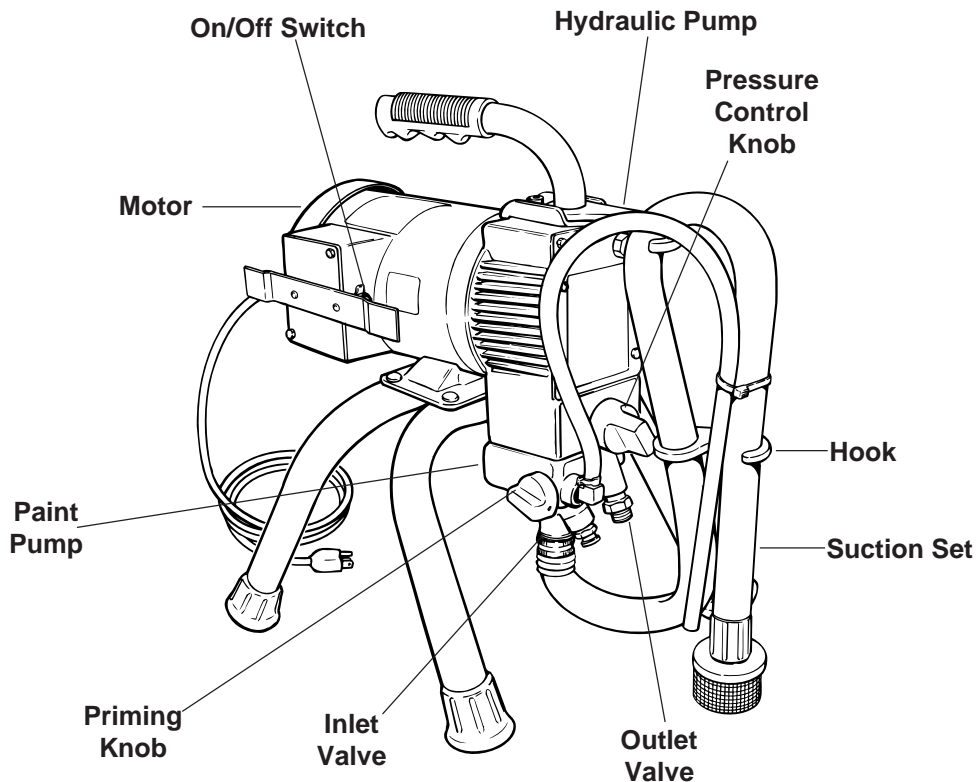

Figure 1.-Sprayer Component Locations

HYDRAULIC PUMP

For the hydraulic pump location, see Figure 1. It operates as follows: The electric motor is connected to the eccentric bearing, which is inside the hydraulic pump. The piston rests on the bearing. The movement of the bearing causes the piston to move up and down. When the trigger on the gun is pulled back, this action moves the pump diaphragm. Diaphragm movement forces the paint through the outlet valve and out the paint hose and spray gun. The paint goes through the spray gun at high pressure, causing it to break-up (atomize) into fine particles. This gives a smooth and even paint coating. Pressure and delivery rate are regulated by the pressure control knob and spray tip size.

PRESSURE CONTROL KNOB

The pressure control knob controls the pressure control valve. It is manually operated. It is located on the front of the hydraulic pump near the bottom of the sprayer (see Figure 1). When the knob is turned **clockwise**, more hydraulic pressure is directed toward the diaphragm. When the knob is turned **counterclockwise**, less hydraulic pressure is directed toward the diaphragm. The pressure control knob regulates the pressure on the diaphragm from 0 PSI when turned fully **counterclockwise** to 3000 PSI when turned fully clockwise.

NOTE

DO NOT START PUMP UNDER PRESSURE. REDUCE PRESSURE TO ZERO BY TURNING PRIMING KNOB TO PRIME POSITION . FAILURE TO DO SO WILL DECREASE MOTOR LIFE.

DIAPHRAGM

The diaphragm is the heart of the sprayer. In addition to pumping paint, it also serves as a gasket between the hydraulic pump and paint pump. As such, it prevents the paint and oil from mixing. The sprayer operates at 1725 strokes per minute. This means that the diaphragm forces a “gulp” of paint out of the spray gun 1725 times every minute.

An insert fits in the inlet hole on the underside of the paint pump. This insert reduces wear by protecting the diaphragm from the metal edges of the inlet hole.

The diaphragm is made of flexible, tough plastic. It is not harmed by common solvents.

NOTE

The diaphragm should be replaced whenever the paint pump is removed. Using the old diaphragm will result in limited diaphragm life and fluid leaks.

PAINT PUMP

The paint pump is located below the hydraulic pump (see Figure 1). The two pumps are bolted together by four socket head capscrews. The diaphragm separates the pumps. The paint pump operates as follows: The piston in the hydraulic pump forces hydraulic oil toward and away from the diaphragm. This action moves the diaphragm up and down. Diaphragm movement forces paint through the spray gun at high pressure.

INLET VALVE

The inlet valve is located on bottom of the paint pump at the front of the sprayer (see Figure 1). The suction nut end of the suction tube screws onto this valve. The valve operates automatically. It controls the flow of paint from the paint container into the paint pump. It does this by opening up when the piston and diaphragm are on the downstroke, allowing a “gulp” of paint to enter the paint pump. The inlet valve then closes when the piston and diaphragm are on the upstroke. This closing prevents paint from going back through the inlet valve into the paint container (inlet valve acts as a check valve). Instead, the paint is directed out the spray hose and spray gun by the outlet valve.

The inlet valve is a one-piece configuration. It contains a device to dislodge a stuck valve by simply pushing the plunger button on the side of the valve body.



The plunger button should never be pushed during operation as this may cause premature failure of the inlet valve.

OUTLET VALVE

The outlet valve is also located on bottom of the paint pump at the front of the sprayer (see Figure 1). It operates automatically, serving as a check valve. When the priming valve is on  (spray) position, the outlet valve directs the flow of paint out into the spray hose and into the spray gun. When the diaphragm and piston act to “gulp” more paint, the outlet valve closes. The closed valve prevents (checks) paint in the spray hose and spray gun from returning to the paint pump.

The outlet valve also contains a device to dislodge a stuck valve. Simply push the plunger button located on the side of the paint block before starting the pump.



The plunger button should never be pushed during operation as this may cause premature failure of the outlet valve.

You can see that the inlet valve and outlet valve work in harmony with the diaphragm and piston. As a "team" they pump paint.

PRIMING KNOB

The priming knob controls the priming valve. It is located on the right front of the paint pump at the front of the sprayer (see Figure 1). It can be manually turned to the ☺ or ⌈≡ position. When on ☺ (prime) it serves to rid the sprayer of air by directing the initial air volume of the inlet valve back into the paint container. It will continue to do this until paint comes through and it is manually switched to the ⌈≡ (spray) position. It then directs the paint out the outlet fitting to the spray hose and on to the spray gun.

The priming valve also serves to relieve pressure on the system during shutdown and cleanup. The pressure is relieved by turning the priming knob to ☺.



CHANGE THE POSITION OF THE PRIMING KNOB SLOWLY. THIS WILL PREVENT BREAKING ANY VALVE PARTS. ALWAYS REDUCE THE PRESSURE WITH THE PRESSURE CONTROL KNOB BEFORE TURNING THE PRIMING KNOB.

SUCTION SET

The complete suction set consists of (1) the suction tube with a suction filter on one end and (2) the return tube (see Figure 1). Both suction and return tube are chemical and oil resistant. One end of the suction tube and one end of the return tube screw onto the paint pump (see Figure 1). These two fittings need to be tight enough to keep air from being drawn in. The other two ends go in the paint container. When the priming knob is turned to ☺ (prime), paint is drawn up the suction tube into the paint pump. The paint pump then routes the paint through the return tube back to the paint container. This primes the painting system. When the priming knob is turned to ⌈≡ (spray), flow is shut off through the return tube and the sprayer can spray.



HIGH PRESSURE OUTLET FITTING

The high pressure outlet fitting is located on the front side of the paint pump (see Figure 1). The paint hose is connected to it. The outlet fitting connections must be very tight. Otherwise, fluid will leak out the connections when pressure builds up in the system.

PAINT HOSE

The high pressure paint hose (see Figure 1) has permanently swaged fittings. It is grounded with a static conductor. This conductor serves to "drain off" any static charge, preventing shock. The conductor is sandwiched between two insulating sheaths which resist breaking and abrasion.



DO NOT IMMERSER THE PAINT HOSE IN ANY SOLVENTS.

The paint hose and the electric cord should always be protected from vehicle traffic and sharp cutting edges or objects. If the paint hose is cut, worn, or damaged it must be replaced with another high pressure grounded hose.

The paint hose can develop leaks from wear, kinking, abuse, etc. A leak is capable of injecting spray material into the skin. Therefore, the paint hose should be inspected periodically. Never repair a paint hose — replace it with another high pressure grounded hose.

SPRAY GUN

The spray gun is connected to the sprayer by the paint hose. The gun will spray when the unit is running, the suction and return tubes are in the spray material, the priming knob is turned to \uparrow the pressure control valve is adjusted, and the spray gun trigger is pulled back.

! WARNING

THE SPRAYTECH ED1150 PUMP IS NOT COMPATIBLE FOR USE WITH HALOGENATED HYDROCARBON SOLVENTS. THE WAGNER G-05, G-09 AND G-10 GUNS MUST NOT BE USED WITH HALOGENATED HYDROCARBON SOLVENTS.

ASSEMBLY OF A NEW SPRAYER

1. Screw the return fitting into the elbow on the front side of the paint pump. Both fittings should be hand tight only, but tight enough to prevent air from being drawn in.
2. Screw the paint hose, wrench tight, onto the outlet fitting on the front side of the paint pump.

SPRAY GUN TIP SELECTION

Select a spray gun tip as follows:

STAINS	LACQUERS & ENAMELS	LATEX
0153315	0153317	0153319
0153415	0153417	0153419

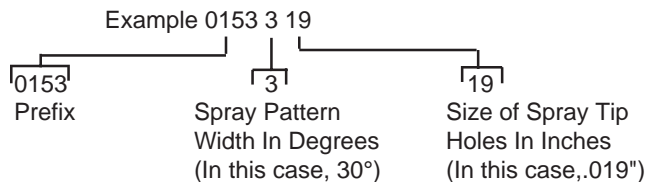

Spray Pattern

Width = 2 x Spray Pattern Width Number
 e.g. 0153319 = 2 X 3 = 6" Spray Pattern 1 Foot from Work
 0153419 = 2 x 4 = 8" Spray Pattern 1 Foot from Work

See Figure 2 for example of a spray pattern.

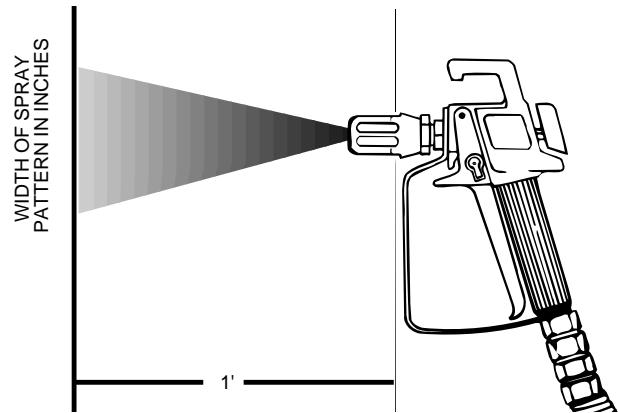

Figure 2.-Example of Spray Pattern

ASSEMBLY OF SPRAY GUN

NOTE
 Follow the Assembly Instructions that came with your gun if it is a brand other than Wagner.

After you have selected the proper spray tip, assemble it onto the spray gun as explained in Steps 1 through 4.

1. Insert the spray tip and sealing washer into the tip guard so that the flats of the spray tip are seated perfectly into the tip guard. See Figure 3.
2. Hand tighten the tip nut onto the diffuser.

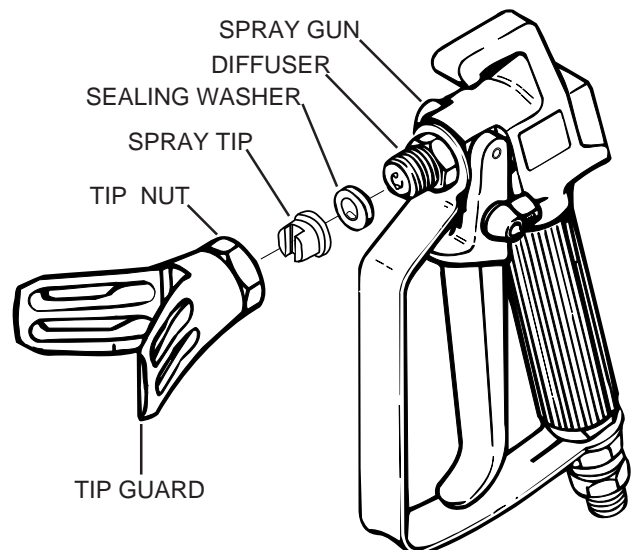

Figure 3.-Spray Tip Assembly Sequence.

- Loosen the tip nut slightly. Turn the tip guard about 1/16 turn counterclockwise from desired spray angle. See Figure 4.

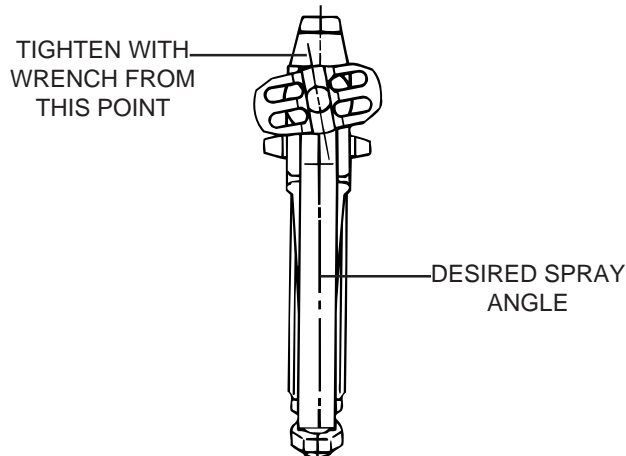

Figure 4.- Spray Gun Tip Guard Position Before Tightening.

- Tighten tip nut. The tip guard should now be in the proper position. See Figure 5.

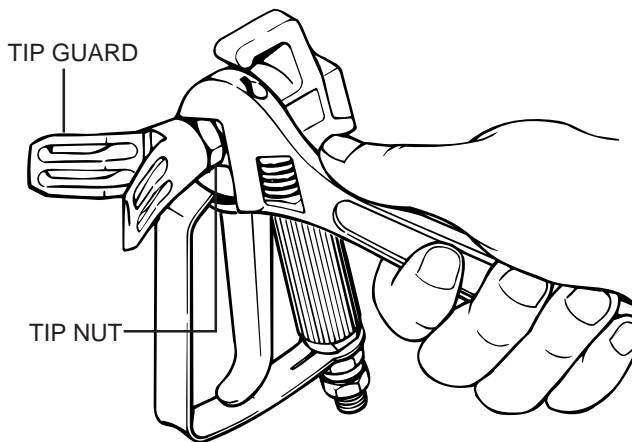

Figure 5.-Tightening Spray Gun Tip.

NOTE

Do not try to change the angle of the tip guard unless the tip nut has been loosened.

- Put the spray gun filter on the gun as shown in Figure 6. First remove the handle from the spray gun housing. Stick the small end of the filter firmly in the spray gun housing. Then screw the handle back on. See Page 26 for Optional Filters.

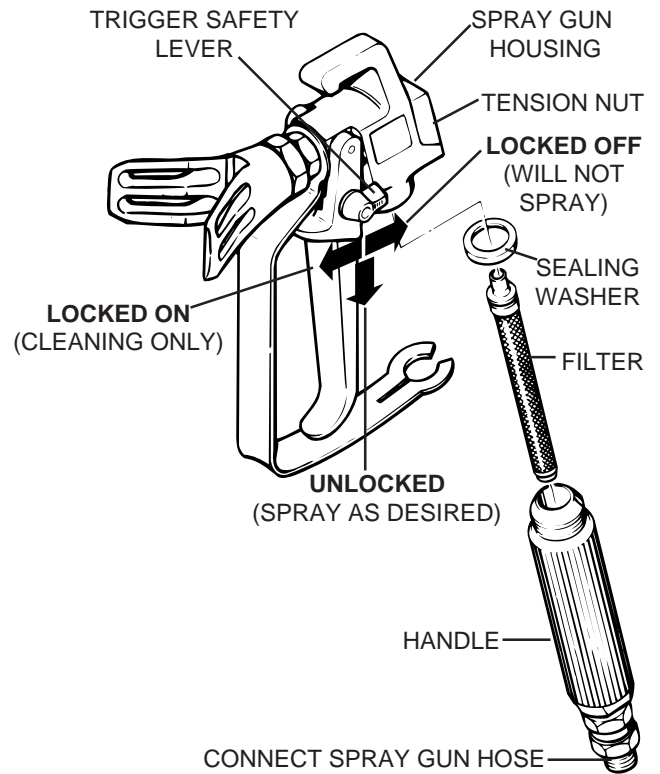

Figure 6.-Spray Gun Filter Assembly and Trigger Safety Lever position.

- Test the trigger tension by unlocking the trigger safety lever and pulling back trigger. To increase tension, turn tension nut (see Figure 6) clockwise. To decrease trigger tension, turn tension nut counterclockwise. After adjusting trigger tension, lock trigger safety lock in locked off position as shown in Figure 6.
- Connect the paint hose to the spray gun. This connection should be tight.

PAINT STRAINING AND THINNING

When a container of paint is exposed to the air for a period of time, “skin” may form on top. This “skin” should be removed. If necessary, the paint should be strained through a strainer.

Under normal conditions, paints used with this airless sprayer do not have to be thinned. However, it is possible that you may use paint that is too thick to be sprayed. In this case you will have to thin the paint.

When thinning paint to spraying consistency (viscosity), use the right thinner — water for latex paints, mineral spirits for oil base paints (or, see the instructions on the paint container for proper thinner).



OPERATION

START UP PROCEDURE

1. CHECK TO BE SURE THE MOTOR SWITCH IS OFF— play it safe.
2. LOCK SPRAY GUN—The spray gun will not spray when the trigger lock is locked.
3. CHECK THE HYDRAULIC OIL— The sprayer was shipped with the proper amount of hydraulic oil in the hydraulic pump. However, the oil should be checked before starting. Look at oil level in oil fill port. When the unit is level, oil level should be at bottom of fill port. Use only hydraulic oil part number 0088009 - 1 quart or part number 0088010 - 1 gallon. Oil capacity is 19 ounces.
4. CHECK FITTINGS—Check to see that these fittings are tight: inlet valve, return tube, outlet valve, outlet fitting, high pressure airless hose, spray gun and allen head paint pump screws.

NOTE

DO NOT TIGHTEN PAINT PUMP SCREWS TO MORE THAN 15 FOOT-POUNDS TORQUE (180 INCH-POUNDS)

5. TURN PRIMING KNOB TO  (PRIME) POSITION— A will appear in the priming knob window. The sprayer must be primed before it will spray.
6. Make sure the suction tube is immersed in paint.
7. PLUG ELECTRIC CORD INTO OUTLET— Electric service must be 115 VAC, 60 Hz. **REMEMBER:** More than 100 feet of extension cord is not recommended. Use additional airless paint hose, not more electric cord.
8. TURN THE MOTOR SWITCH ON.
9. PRIME THE PUMP—Let the paint circulate until no air bubbles show in the paint (about 2-3 minutes). Turn the pressure control valve at least 1/2 turn clockwise from fully decreased position to prime the pump with paint.
10. BLEED THE AIR—If unit fails to prime when started up, it may be necessary to bleed (vent) the air out of the hydraulic system. Bleed the air as follows:
 - A. Turn pressure control knob all the way **counter**-clockwise, turn priming knob to , and let sprayer run

a few minutes. It is sometimes helpful to turn ON-OFF switch ON and OFF to assist in bleeding.

- B. Now turn pressure control knob **clockwise** to prime the pump. When sprayer is primed, paint will come out of the return tube. This may take 2-3 minutes. If sprayer does prime, turn pressure control knob **counterclockwise** and repeat procedure.

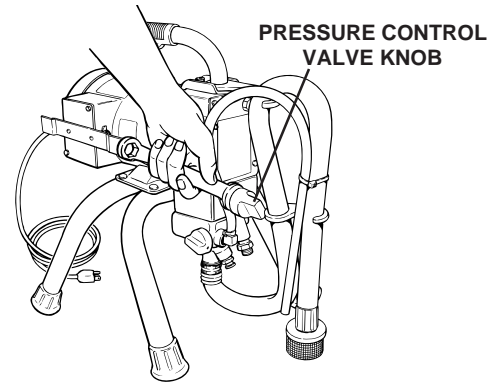



Figure 7.-Bleeding Air Out of the Sprayer.

You will also have to follow the above bleeding procedure when you change hydraulic oil, if you remove the paint pump or work on the hydraulic housing, or if the sprayer loses prime due to rough handling.

11. MAKE SURE PRESSURE IS REDUCED BY TURNING THE PRESSURE CONTROL KNOB COUNTERCLOCKWISE.
12. TURN PRIMING KNOB TO  (SPRAY) POSITION —  will appear in the knob window.
13. UNLOCK SPRAY GUN TRIGGER — When the trigger is unlocked, the trigger safety lever will point in the same direction as the trigger (see Figure 6).
14. ADJUST PRESSURE — Adjust the pressure control knob on the sprayer to lowest pressure needed for good operation. Pull spray gun trigger back and spray a test area to check spray pattern.
15. YOU ARE NOW READY TO SPRAY — See “SPRAY PAINTING” for tips on how to spray.

SPRAY PAINTING

You can learn to spray paint as easy as you can learn to paint with a brush or roller. You can get a professional looking job in a safe manner by following the spray painting tips below.

1. Heed all WARNINGS and CAUTIONS that are listed on pages 2 thru 6 at the front of this manual. Take time out now to reread them.

- Avoid sharp bending and kinking of the paint hose. The paint hose and electric cord should be kept clear of traffic and sharp cutting edges or objects.
- Use the lowest pressure possible when spraying. Too much pressure shortens equipment life. It also causes faster than normal wear on the spray tip.
- Determine the best spraying distance (distance from spray tip on the spray gun to the work). If the spray gun is held too close to the work, you will have paint buildup that will cause sags and runs. If the spray gun is held too far from the work, "fogging" will result.

The correct distance should be about 10 to 12 inches. Keep this distance for the entire length of the stroke. Of course, the shape of some work surfaces will not permit this. However, the same spraying distance should be kept whenever possible.

- Do not move the spray gun by flexing your wrist. The result of this is shown in Figure 8. Rather, move the spray gun with a smooth stroke of the entire arm and shoulder. Maintain the same arm speed all the way through the stroke. The result of this is shown in Figure 9.

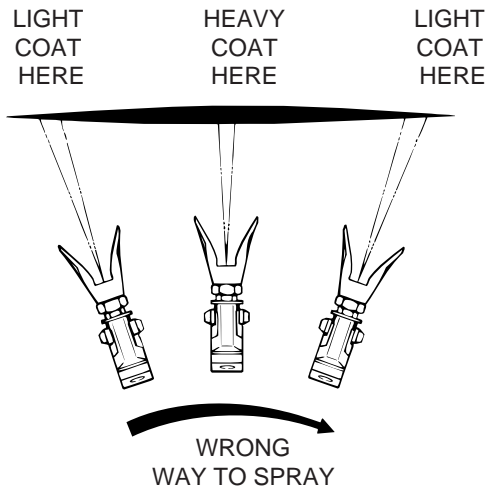

Figure 8.-Result of Flexing Wrist While Spraying.

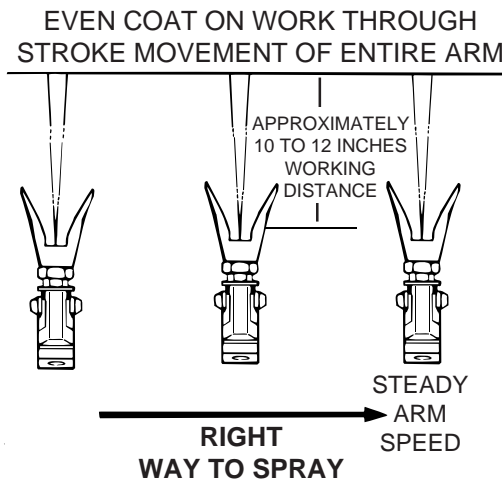

Figure 9.-Result of Smooth Arm Stroke and Steady, Even Speed While Spraying

- Keep the spray gun perpendicular to the work as shown in Figure 10.

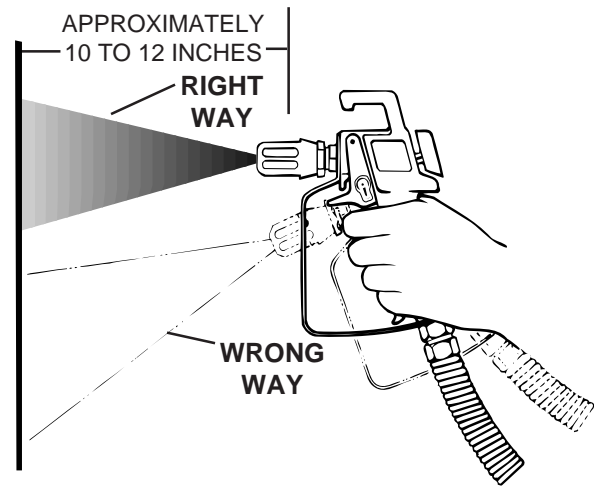

Figure 10.-Right and Wrong ways to Hold Spray Gun Toward Work.

- The spray gun should be triggered (turned off and on) on each stroke. This will save paint and avoid paint buildup at the end of the stroke. However, do not trigger during the middle of a stroke. This will result in an uneven spray and splotchy work. See Figure 11 for proper triggering on a left-to-right stroke. Reverse for a right-to-left stroke.
- Move the spray gun at a rate of speed that is comfortable for you. If you have to move your arm **too fast** in order to prevent excessive paint buildup, either (1) lower the pressure by turning the pressure control knob counter-clockwise, or (2) use a spray tip with a smaller hole. If you have to move your arm too slow in order to get a good coating, either (1) raise the pressure by turning the pressure control knob clockwise, or (2) use a spray tip with a larger hole. You should always keep the spray gun moving when making a stroke. Slowing down in one place will cause sags or runs.

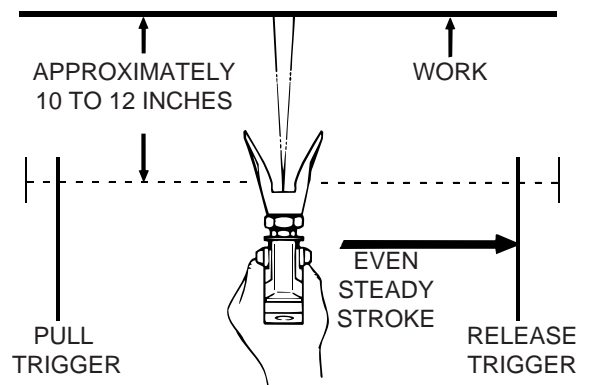



Figure 11 -Proper Way to Trigger Spray Gun.

- Overlap each stroke by about 40% to 50%. The overlap will insure a paint coating that is uniform across the work. One way to get good overlap is to point the spray gun at the edge of the last stroke.

SPRAY TIP PLUGGING

The spray tip can be plugged by foreign matter and “skin” in the paint. Excessively large paint pigments can also plug the tip. If the tip becomes plugged while spraying, proceed as follows:

1. Lock spray gun trigger OFF so that the spray gun can't spray.
2. Turn sprayer ON/OFF switch OFF.
3. Reduce pressure by turning the pressure control knob counterclockwise. Turn priming valve knob to  to bleed pressurized paint in paint hose and spray gun back into paint container.
4. Remove tip guard assembly with spray tip and sealing washer from spray gun as shown in Figure 3, page 10.
5. Remove spray tip and sealing washer from tip guard assembly.
6. Soak tip guard assembly, spray tip, and sealing washer in solvent. Then clean them with a stiff brush. A toothpick, wood chip, or sharpened matchstick can be used to clean the spray tip hole.



Never clean the spray tip hole with a wire or metal object as these items will cause damage.

7. Reassemble the spray tip, sealing washer, and tip guard assembly onto the spray gun the same way you did when you assembled the unit. See “ASSEMBLY OF SPRAY GUN”, page 10.

SPRAY GUN FILTER CLEANING AND CHANGING

Clean or change the spray gun filter at least once per painting day, some types of latex paint may require filter cleaning or changing more often.

The filter is best cleaned with a brush dipped in appropriate solvent. Never poke the filter with a sharp instrument.

If the filter is not cleaned or changed at the proper time, it will plug from the top down. When there is about 1 inch or so of the filter left that isn't plugged, the heavy flow of paint will blow pinholes in the filter. An example of this is shown in Figure 12.

To remove and replace the filter, proceed as follows:

1. Lock spray gun trigger OFF.
2. Turn sprayer ON-OFF switch OFF.

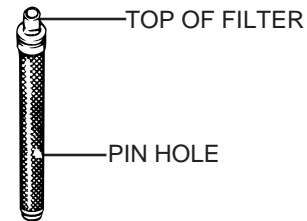



Figure 12.-Example of Pinhole in Spray Gun Filter.

3. Reduce pressure by turning the pressure control knob counterclockwise. Turn priming knob to . This will drain the pressurized paint in the paint hose and spray gun back into the paint container.
4. Remove the paint hose from the spray gun as shown in Figure 13.
5. Remove the handle from the spray gun.
6. Remove the old filter. Use a new filter, or clean the old filter.
7. Stick small end of new or cleaned filter into spray gun housing.
8. Screw handle back on spray gun.
9. Connect paint hose to spray gun.

Extra spray gun filters should be kept on hand.

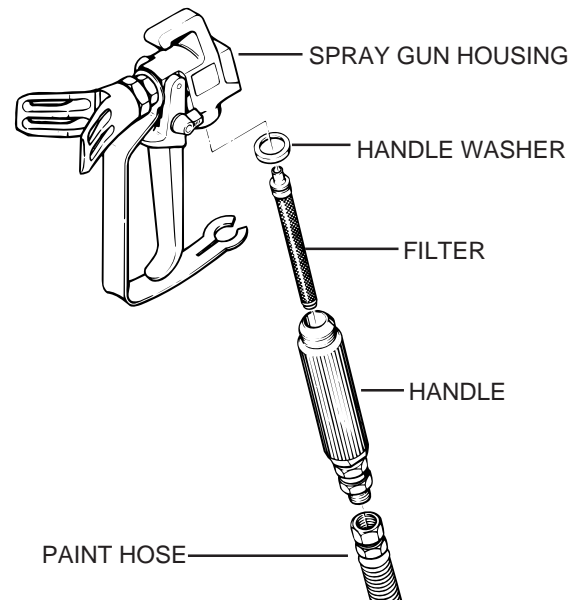



Figure 13.-Spray Gun Filter Removal and Replacement.





SHUTDOWN AND CLEANUP

You should clean and oil your sprayer as soon as you finish a job. **Do not store the sprayer unless it has been cleaned and oiled.**

When you shut down, clean up with water if you were using latex paint and clean up with solvent if you were using oil base paint.

If you are going to stop spraying for an hour or two just relieve the pressure in the sprayer by turning the priming knob to , cover your paint container to keep dirt out and place tape over the spray tip to keep air from drying paint in the tip.

Shut down and clean up as follows:

1. Reduce pressure by turning pressure control knob counterclockwise. Turn priming knob to . Remove suction hose only from paint container, hold it above container and allow sprayer to pump itself dry. Remove tip guard, spray tip and washer and let soak clean.
2. Have container of hot soapy water for cleaning after spraying with latex paint or suitable solvent for oil base paints. Do not clean with mineral spirits if using latex paint because it makes jelly.
3. Place suction and return tubes in the solvent or warm soapy water. Increase pressure and let circulate for 2-3 minutes.
4. To save remaining paint in spray hose, carefully trigger gun into and against side of paint container. Be careful of splashing. Turn priming knob to . Turn pressure up and watch inside of container for cleaning solvent to come through, then shut off gun and place in cleaning container.
5. Trigger gun and let cleaning solvent circulate for approximately 2-3 minutes.
6. Turn priming knob to  and shut unit off. Unscrew gun handle. Remove and clean filter. Install filter in gun and reassemble spray tip, washer and guard.
7. With priming knob on , remove suction tube from cleaning container to allow sprayer to pump dry.
8. Take a clean container of water or solvent and using low pressure pump through system until clear. If cleaning with water, turn to  and pump lacquer thinner through pump. This will clean any paint particles still in the system and remove water.
9. Take suction tube out of container and let sprayer run itself dry.

©1995 WAGNER SPRAY TECH CORPORATION. ALL RIGHTS RESERVED.

10. Remove suction hose from inlet valve and let valve suck in a small amount of light oil. This will oil pump parts and keep them from corroding.



It is very important that you oil the inlet valve as stated in step 10 above. Oil inlet valve after EVERY job.

11. Turn ON-OFF Switch OFF.

MAINTENANCE

Check the hydraulic oil level before each use and after every 20 run hours. To check hydraulic oil level, see number 3, 'CHECK THE OIL', Page 12.

Change the hydraulic oil after the first 20 run hours and every 200 hours thereafter. To change hydraulic oil, proceed as follows:

1. Remove the oil filler plug from the hydraulic housing face plate.
2. Drain out the old hydraulic oil.
3. Fill hydraulic housing with approximately 19 ounces of hydraulic oil. Use only hydraulic oil part number 0088009 (1 quart) or part number 0088010 (1 gallon). Replace oil fill plug.
4. Since air may enter the system when the oil is changed, the sprayer may have to be vented (bled). To bleed out the air, see number 10, 'BLEED THE AIR', Page 12.

You will also have to bleed the air out of the system if you remove the paint pump or go into the hydraulic housing, or if the sprayer loses prime due to rough handling.

IMPORTANT!

Tighten the (4) Pump Block Bolts after the first 20 hours of use.

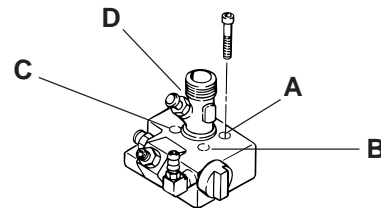

To tighten, use the 6mm allen wrench supplied in the literature kit. Use a criss cross pattern when tightening. First A, then C, then B, then D. If you have a torque wrench use 13-15 Ft./Lbs.

SUCTION FILTER CLEANING

The suction filter is located on the end of the suction tube. A clean suction filter gives full delivery capacity and a constant level of spraying pressure. Clean the suction filter as needed with a brush dipped in solvent.

CHECKING OPERATION OF INLET VALVE

See Figure 14 for location of inlet valve. The inlet valve should be checked if the sprayer draws up little or no paint. It is a good practice to check inlet valve operation before spraying. If the sprayer has been in storage, the inlet valve may be sticky.

To check inlet valve operation, proceed as follows:

1. Turn priming knob to ☺.
2. Turn ON-OFF switch ON.
3. Let inlet valve suck against the palm of your hand. If little or no suction is felt repeatedly move the plunger in and out to lift inlet valve stem, as shown in Figure 14. Put in a few drops of light oil or cleaner.

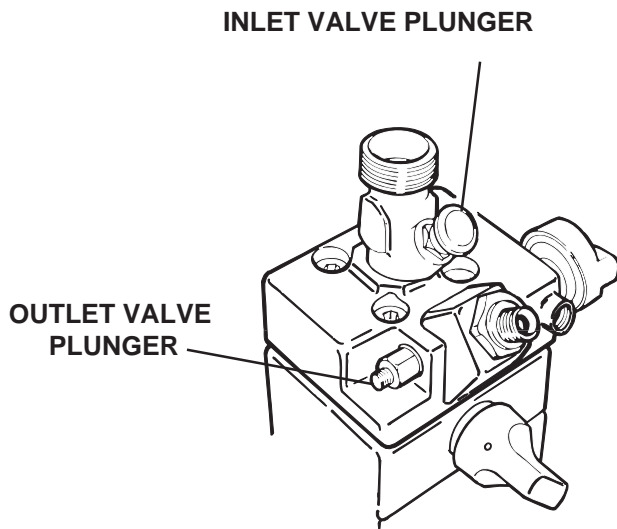

Figure 14.-Inlet & Outlet Valve Plungers

CHECKING OPERATION OF OUTLET VALVE

The outlet valve should be checked if the sprayer draws up little or no paint, or draws up paint, but doesn't build pressure. It is a good practice to check outlet valve operation before spraying. If the sprayer has been in storage, the outlet valve may be sticky.

To check outlet valve operation, proceed as follows:

1. Turn priming knob to ☺.
2. Turn ON-OFF switch to ON.
3. If above symptoms occur during priming of pump simply:
 - Reduce pressure to 0.
 - Push the plunger in and out to lift the ball off the seat. See Figure 14.

CAUTION

THE PLUNGER DEVICE MUST BE LOOSENED PRIOR TO ANY SERVICE OF THE OUTLET VALVE.

NOTE

Your sprayer was shipped with two extra outlet valve springs. Periodic replacement is necessary to maintain top performance. Suggested replacement is every 35 to 50 hours of operation for best performance. Periodic replacement of the outlet valve spring also increases the life of the inlet valve.

REPLACING DIAPHRAGM OR DIAPHRAGM PARTS

The diaphragm is the only separation between the paint pump and the hydraulic pump. It pumps paint, but it also serves as a gasket between the hydraulic pump and paint pump. If the diaphragm membrane ruptures, paint will probably get into the hydraulic housing. If adequately cleaned up soon enough, the parts (bearing, piston, etc.) can be saved. If the hydraulic housing is not cleaned up soon enough, you may have internal freeze-up.

When the diaphragm or diaphragm parts have to be replaced, proceed as follows:

1. Remove the 4 paint pump screws with a 6 millimeter allen wrench. As you remove the 4 screws, also remove the 4 washers that may remain in the holes.

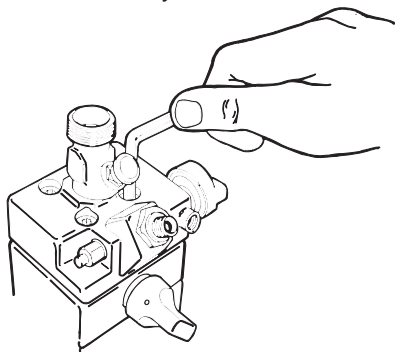

Figure 15. - Remove paint pump screws

2. Take the paint pump housing off the hydraulic pump housing.
3. Remove the old diaphragm and the old insert ring.

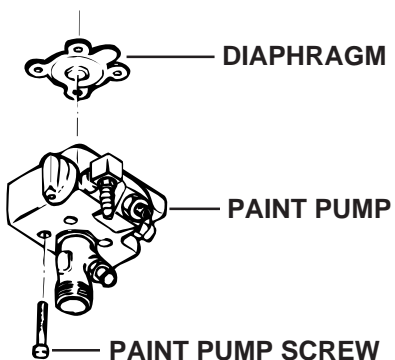

Figure 16.-Diaphragm Parts and Their Relationship to Other Parts of the Sprayer.

4. When a new diaphragm is installed, a new insert ring (see Figure 16) should also be installed. Install the new Insert. Be sure to put the flat surface of the insert ring into the flat surface of the paint pump.

5. Install the new diaphragm. Put the membrane stem and nut side of the diaphragm in the hydraulic pump housing hole.
6. Put the paint pump back on. Before installing the 4 paint pump screws, put Anti-Seize Lubricant on the screw threads. (This prevents the steel screws from galling and seizing in the aluminum hydraulic pump). Now install the 4 new paint pump washers and 4 screws using a 6 millimeter allen wrench (see Figure 17).

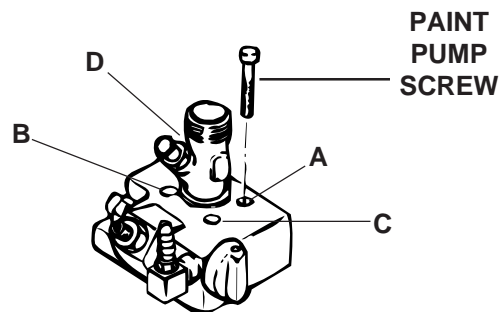

Figure 17-Tightening Paint Pump Screws.

7. Tighten opposite screws in turn as shown. (A-B, C-D). Tighten screws evenly to 13-15 ft lbs. (156-180 inch-pounds) torque. Begin at screw A tightening to 10 ft lbs. continue to screw D. Repeat this step until all screws have attained a torque of 10 ft. lbs. Repeat sequence tightening to 14 ft lbs. and repeat one more time tightening to 14 ft lbs. Following this tightening sequence will assure proper seating of the diaphragm.

NOTE:

Improper torquing sequence of the paint pump screws may cause damage to diaphragm and inefficient pump performance. Proper torque also prevents hydraulic oil from leaking out between the paint pump and the hydraulic housing. **It is recommended that a new unit be re-torqued after the first 20 hours of operation.** Thereafter, tighten the paint pump screws after every 3 or 4 operations. One lockwasher should always be used with each of the four paint pump screws.

8. After replacing or repairing the diaphragm, the sprayer will have to be bled. See Number 9, "**BLEED THE AIR,**" page 12.

USE OF ANTI-SEIZE LUBRICANT

You should use Anti-Seize Lubricant (part number 0093930) any time you are screwing dissimilar metal thread connections together. On your sprayer these connections are; (1) steel outlet valve into paint pump, (2) steel inlet valve into paint pump, (3) steel priming valve into paint pump, (4) steel paint pump screws into aluminum hydraulic pump, and (6) steel pressure control valve into iron pressure vessel/hydraulic pump.

TROUBLESHOOTING

Provided you have followed the instructions, the sprayer will operate efficiently and give trouble-free service. Should any unexpected problem arise you can, in most cases, remedy the problem by following the chart below.

Problem	Cause	Remedy
Sprayer does not startup	<ol style="list-style-type: none"> 1. Sprayer not plugged in 2. Blown fuse in circuit 3. No voltage or low voltage at wall plug 4. Bad sprayer ON-OFF switch 5. Damaged cord or extension cord, or cord capacity too low 6. Defective motor 	<ol style="list-style-type: none"> 1. Plug in 2. Replace fuse 3. Test power supply voltage 4. Replace switch 5. Replace with 3-prong cord. Any extension cord used must be 3-wire, 12 gauge minimum, with a 3-wire plug that will plug into a 3-wire electrical outlet. 6. Repair or replace. Take to SprayTECH Authorized Service Center.
Sprayer starts up but does not draw up paint	<ol style="list-style-type: none"> 1. No paint or suction tube not totally immersed in paint 2. Suction filter clogged 3. Suction tube loose at inlet valve 4. Suction tube damaged or defective 5. Priming valve plugged 6. Hydraulic oil level very low or empty 7. Inlet valve stuck 8. Inlet valve damaged (paint is drawn up and leaks through inlet valve) 9. Outlet valve stuck 10. Diaphragm membrane ruptured, broken diaphragm spring, cracked diaphragm disk, or loose diaphragm nut 11. Loose oil suction tube in hydraulic housing 12. Scored piston or cylinder 13. Wrong grade of hydraulic oil, or using fluid other than hydraulic oil 14. Rear motor fan cover bent 	<ol style="list-style-type: none"> 1. Add more paint or immerse suction tube in paint 2. Clean or replace filter 3. Clean connection and tighten firmly 4. Replace tube 5. Take valve off and clean it 6. Fill only with hydraulic oil part number 0088009 (quart) or 0088010 (gallon). Caution: do not overfill 7. Push Inlet Valve Plunger to free stuck valve 8. Replace inlet valve 9. Push Outlet Valve Plunger to free stuck valve 10. Clean hydraulic housing if needed (blown diaphragm may cause internal freezeup). Replace defective diaphragm parts or tighten nut if loose 11. Replace tube 12. Replace piston. If cylinder is scored, replace hydraulic housing 13. Use only hydraulic oil part number 0088009 (quart) or 0088010 (gallon). Change initial fill after first 20 hours of operation. Change every 200 hours there after. Bleed after changing 14. Remove fan cover and straighten
Sprayer draws up paint but pressure does not build up	<ol style="list-style-type: none"> 1. Priming valve defective (paint runs back via return hose) 2. Hydraulic oil level low 3. Diaphragm membrane ruptured, cracked diaphragm disk, broken diaphragm spring, or loose diaphragm nut 4. Outlet valve stuck, dirty, or has worn parts 5. Defective suction tube 6. Scored piston or cylinder 7. Cracked hydraulic housing or paint pump housing 	<ol style="list-style-type: none"> 1. Replace valve 2. Fill to appropriate level using only hydraulic oil part number 0088009 (quart) or 0088010 (gallon) 3. Clean hydraulic housing if needed. Replace defective diaphragm parts or tighten nut if loose 4. Dismantle valve. Clean or replace valve spring first. If this does not work, replace ball 5. Replace tube 6. If piston is scored, replace piston. If cylinder is scored, replace hydraulic housing 7. Replace housing

TROUBLESHOOTING (Continued)

Problem	Cause	Remedy
Sprayer draws up paint, pressure builds up, but drops away markedly when gun is opened (low performance)	<ol style="list-style-type: none"> 1. No spray tip on gun 2. Spray tip hole too large 3. Suction filter clogged 4. Gun filter plugged 5. Gun filter too fine for coarse paint being sprayed 6. Suction tube not firmly tightened to inlet valve 7. Leaky suction tube 8. Leaky priming valve 9. Worn paint pump outlet valve seat, ball, or spring 10. Worn Inlet valve 11. Pressure control valve worn or damaged 	<ol style="list-style-type: none"> 1. Put on correct tip 2. Select smaller tip or try newer tip 3. Clean or replace filter 4. Clean or replace filter every 4 hours. Keep extra filters on hand 5. Use correct filter or strain/thin paint 6. Clean connection thoroughly and tighten 7. Clean connection thoroughly and tighten or replace tube 8. Replace valve 9. Replace defective part(s) 10. Replace valve 11. Replace valve - Take to Authorized SprayTECH Service Center
Pressure fluctuation	<ol style="list-style-type: none"> 1. Loose suction tube at inlet valve 2. Leaky suction tube at inlet valve 3. Leaky or dirty priming valve 4. Leaky, worn, or damaged inlet valve 5. Outlet valve may be stuck, dirty, or have worn parts 6. Dirty pressure control valve 7. Worn or damaged pressure control valve 8. Pinhole in diaphragm membrane 9. Loose oil suction tube, causing air in hydraulic system. Or, oil suction tube may be partly plugged 10. Eroded paint pump block 11. Cracked hydraulic housing 	<ol style="list-style-type: none"> 1. Clean connection thoroughly and tighten 2. If tightening doesn't work, replace suction nut and adapter 3. Clean or replace valve 4. Replace valve 5. Dismantle valve. Clean or replace valve spring first. If this doesn't work, replace ball 6. Take to Authorized SprayTECH Service Center 7. Take to Authorized SprayTECH Service Center 8. Replace diaphragm membrane 9. Clean oil suction tube if necessary and reglue 10. Replace block 11. Replace housing
Paint in hydraulic housing	<ol style="list-style-type: none"> 1. Ruptured diaphragm membrane 	<ol style="list-style-type: none"> 1. Take to Authorized SprayTECH Service Center
Spray gun won't shut off	<ol style="list-style-type: none"> 1. Insufficient trigger spring pressure on gun 2. Worn ball or diffuser seat or gun 3. Foreign matter or paint buildup between ball and diffuser on gun 	<ol style="list-style-type: none"> 1. Increase trigger spring pressure by adjusting rear tension nut 2. Replace ball or diffuser or gun 3. Disassemble gun and clean

TROUBLESHOOTING (Concluded)

Problem	Cause	Remedy
Spray gun leaks	1. Worn valve ball holder on gun	1. Replace valve ball holder
Spray gun won't spray	1. Out of spray material 2. Spray tip or gun filter plugged	1. Get more spray material 2. Clean spray tip. Clean or replace gun filter
Low paint output from spray gun	1. Partially plugged spray tip or filter	1. Clean or replace gun filter. Clean spray tip
Spray gun sprays without trigger being pulled back	1. Valve ball holder not in correct position	1. Adjust rear tension nut. If this doesn't work, examine valve ball holder and replace if necessary

NOTE 1: If a return line that is completely submerged in paint causes bubbles after priming, you probably have a vacuum leak in the suction set. To remedy, tighten suction set.

NOTE 2: Should oil seep through the face of the hydraulic and paint pump sections, firmly tighten the four socket-head capscrews. Use the 6 millimeter allen wrench. Follow the procedure described in Item 8, page 17.

NOTE 3: More than 100 feet of extension cord is not recommended. Use more paint hose, not more extension cord. Shorter extension cords will assure maximum electrical power for proper operation.

NOTE 4: When the priming valve is on \uparrow (spray) and you are getting flow back through the return tube, remove priming valve and clean or replace.

NOTE 5: The electric motor should always be kept clean and dry. Paint acts as an insulator. Therefore, too much paint on the motor will cause it to overheat.

BEFORE YOU CALL
Have the following information available:

Model # _____
Serial # _____
Purchase Date _____

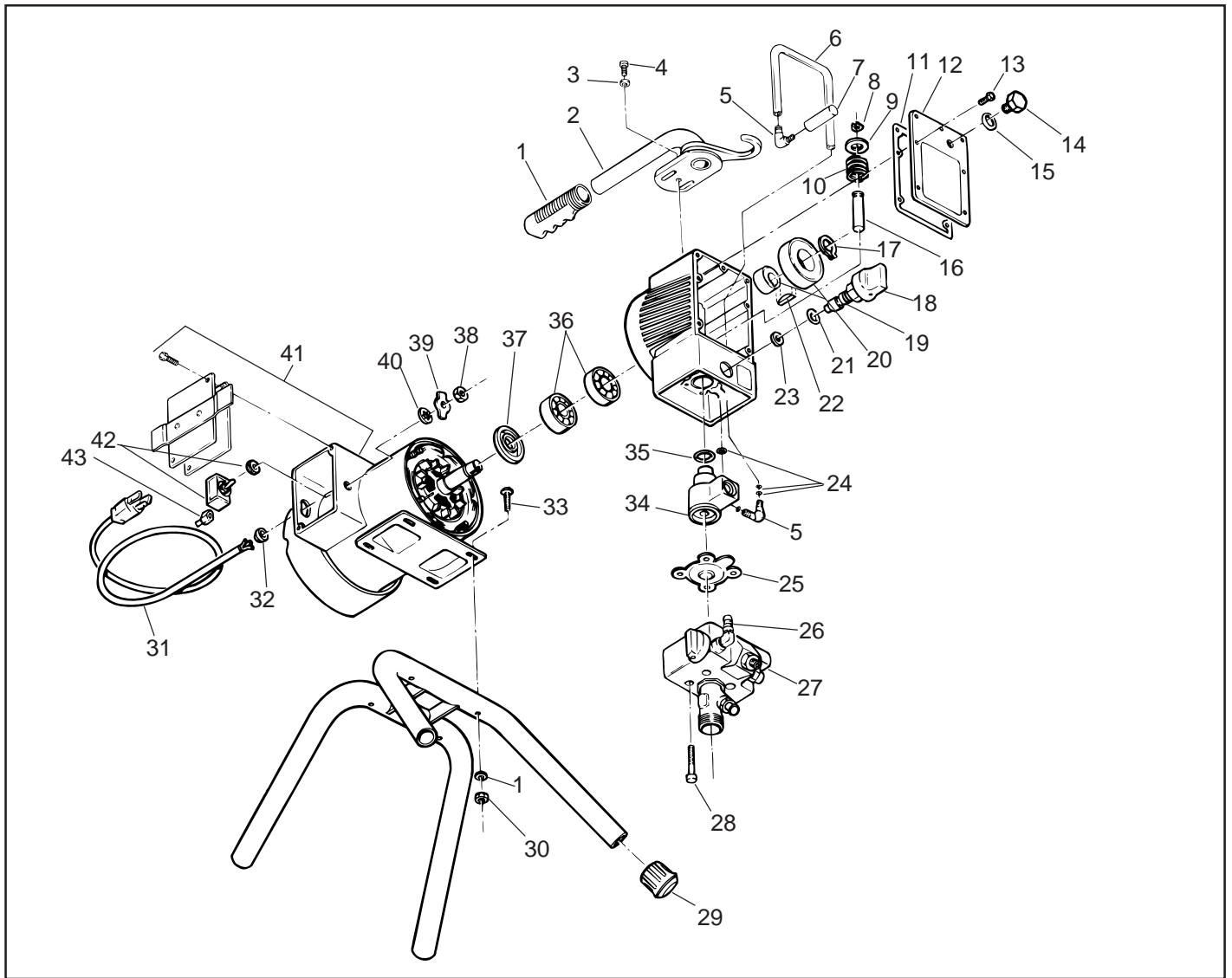

FINAL ASSEMBLY — Figure 18

ITEM	PART NO.	DESCRIPTION	QTY.	ITEM	PART NO.	DESCRIPTION	QTY.
1	0288478	Grip,	1	23	0047487	Washer, Copper	1
2	0294511	Handle	1	24	0089934	O-Ring	3
3	0088328	Washer, Lock, 5/16"	4	25	-----	Diaphragm Assembly, See Fig. 19	1
4	9800325	Screw, Soc. Hd. 8mm x 16mm Lg.	1	26	9885552	Elbow	1
5	0089935	Elbow, Barb	2	27	-----	Paint Pump Assembly (See Figure 19)	1
6	0270504	Tubing, 5/16" O.D., 3/16" I.D.	1	28	0089945	Screw, Soc. Hd. Cap, M8 x 80	4
7	0294656	Filter	1	29	0294533	Foot, Rubber	4
8	9822515	Ring, Retaining	1	30	0090497	Nut, Hex. 5/16"- 18	1
9	0270501	Washer	1	31	0090559	Cord, Power	1
10	0005311	Spring	1	32	0089726	Clamp, Cord Locking	1
11	0089937	Gasket	1	33	9802533	Bolt, Carriage, 5/16" x 18 x 1	1
12	0294513	Cover	1	34	0294495	Vessel, Pressure	1
13	9800049	Screw	1	35	0089932	O-Ring	1
14	0034307	Cap, Filter	1	36	0270490	Bearing, Ball	2
15	9871044	O-Ring	1	37	0270524	Seal, Tip	1
16	0270488	Piston	1	38	-----	Nut, (Included with Item 43)	1
17	0047393	Ring, Retaining	1	39	0089986	Plate, On-Off	1
18	0288775	Knob, Pressure Valve	1	40	0089985	Washer, Internal Tooth	1
19	0089504	Valve, Pressure Assembly (Includes Item 21)	1	41	0294530	Motor	1
20	294265	Bearing with Eccentric	1	42	0089453	Switch, Electric	1
21	0089501	O-Ring	1	43	0089799	Terminal, Insulated	1
22	0089829	Key, Woodruff	1				

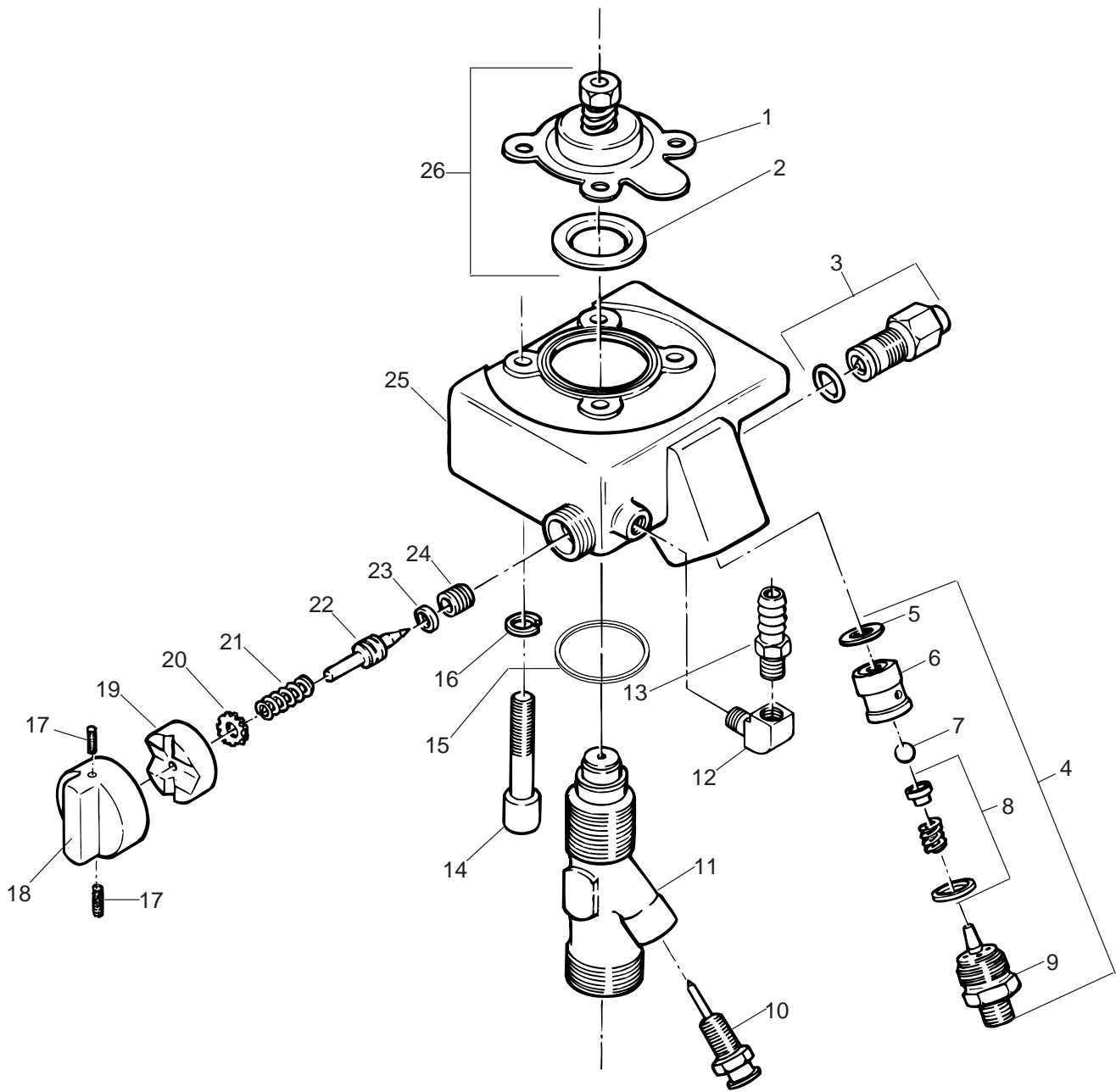

Paint Pump Assembly — Figure 19

PAINT PUMP ASSEMBLY — Figure 19

ITEM	PART NO.	DESCRIPTION	QTY.	ITEM	PART NO.	DESCRIPTION	QTY.
1	0270201	Diaphragm assy.	1	13	9885553	Fitting, Hose, 1/8 nptm x 3/8	1
2	0270494	Ring, diaphragm	1	14	0089945	Screw, soc hd cap M8x89	4
3	0294216	Pusher assy, outlet valve (Includes O-ring P/N 9971327)	1	15	0089482	Washer, Sealing, Nylon	1
4	0294672	Kit, repair outlet valve	1	16	0088328	Washer, lock 5/16	9
5	0010778	Seal, ball seat	1	17	9801103	Screw, set	2
6	0294264	Housing assy., outlet seat	1	18	0288748	Knob	1
7	0270491	Ball	1	19	0154375	Cam	1
8	0278907	Kit, Repair, Outlet Spring	1	20	0090512	Washer, star	1
9	0294508	Outlet fitting	1	21	0036352	Spring	1
10	0253218	Pusher assy., inlet valve	1	22	0281317	Stem/ball assy., prime valve	1
11	0294213	Inlet valve assy. (Includes Item 15)	1	23	0090523	O-Ring	1
12	9885552	Elbow	1	24	0281316	Seat, ball assy., prime valve	1
				25	0294494	Paint pump block	1
				26	0294673	Kit, Repair, Diaphragm	1

BEFORE YOU CALL

Have the following information available:

Model # _____

Serial # _____

Purchase Date _____

ACCESSORIES

Part No.	Description
0153---	Tungsten C arbid Flat Tips
0153003	Tip Guard, Flat Tip
0093641	Hopper Assembly, 6 gallon
0291004	Hose, Whip End, 3' x 3/16"
0291003	Hose, Whip End, 5' x 3/16"
0291002	Hose, Wireless, 25' x 1/4"
0291000	Hose, Wireless, 50' x 1/4"
0093896	Hose Connector, 1/4" x 1/4"M
0088154	Pressure Gauge
0153043	Tip Extension, 6"
0153042	Tip Extension, 12"
0152001	Power Roller Gun Attachment
0152308	Roller Cover, 3/8" Nap
0152307	Roller Cover, 1/2" Nap
0152309	Roller Cover, 3/4" Nap
0152310	Roller Cover, 1 1/2" Nap
0152235	Roller Cover, 1/2" Nap
0152236	Roller Cover, 3/8" Nap
0152237	Roller Cover, 3/4" Nap
0152238	Roller Cover, 1-1/4" Nap
0152700	Adapter, Power Roller Extension
0088009	Hydraulic Oil, quart
0088010	Hydraulic Oil, gallon
0270188	G-10 Airless Spray Gun
0093930	Anti-Seize Compound
0152900	R-10 Telescoping Roller, 12" x 3/8" nap
0152909	R-10 Telescoping Roller, 9" x 3/8" nap
0294672	Kit, Repair Outlet valve
0294673	Kit, Repair diaphragm

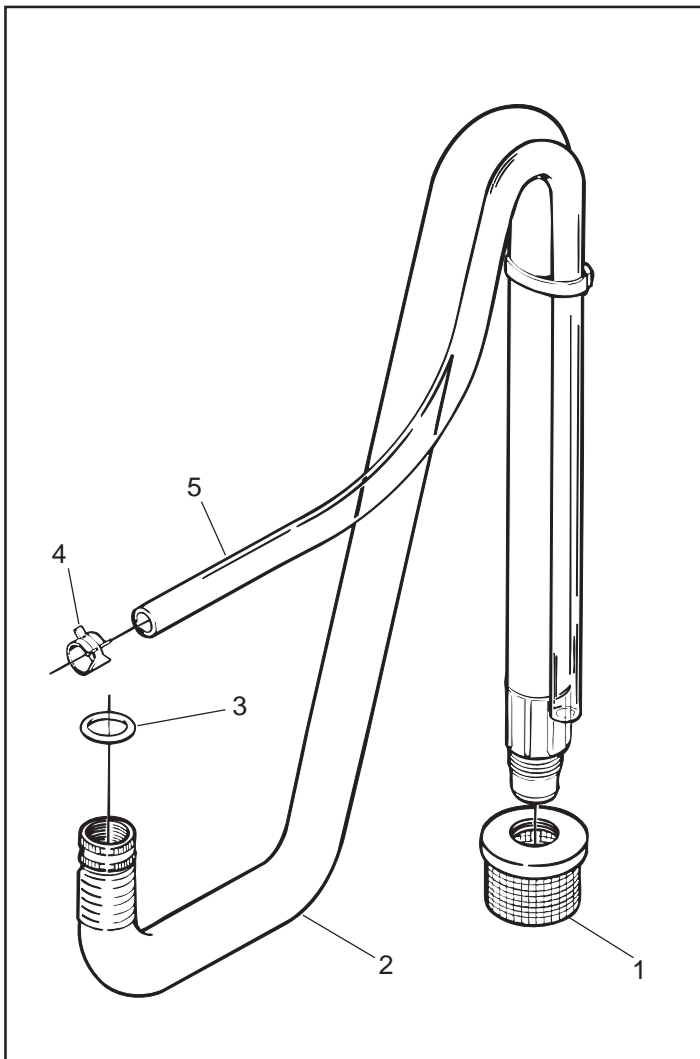

0294218 SUCTION SET ASSEMBLY

ITEM	PART NO.	DESCRIPTION	QTY.
1	0279305	Filter, housing	1
2	0294217	Suction Hose	1
3	9871047	O-ring	1
4	0294665	Clip, hose	1
5	0269321	Return tube	1

Part No.	Application	Filter Type	Mesh Number	Color of Filter Body
0089960	Synthetic resin Enamels, clean varnishes, stains azures	Extrafine	0.084 mm	Red
0089959	Base coat enamels, Primer enamels, fillers, marking paints, textured enamels	Fine	0.140 mm	Yellow
0089958	Emulsions, Latex paints, acrylic paints	Medium	0.315 mm	White
0089957	Filler paints, large area surfaces	Coarse	0.560 mm	Green

VERSATIP™ GUARD		
	Includes Seal. fits 11/16" thread	0270177
VERSATIP™ GUARD		
	Includes Seal. fits 7/8" thread	0270178
VERSATIP™ ASS'Y		
	Includes guard, seal, 517 reversible tip.	
	Fits 11/16" thread	0270175
VERSATIP™ ASS'Y		
	Includes guard, seal, 517 reversible tip.	
	Fits 7/8" thread	0270176
VERSATIP™ Sizes...		
	313 through 319	0299----
	411 through 431	0299----
	511 through 543	0299----
	617 through 623	0299----
	715 through 723	0299----
	819 through 823	0299----

ORDER BY USING PREFIX 0299--- AND FAN AND TIP SIZE FOR LAST 3 DIGITS (I.E. FOR 0.013 TIP WITH 6" FAN ORDER P/N 0299313)

Limited Warranty

Contractor Airless Spray Equipment

What Is Covered By This Warranty:

This product, manufactured by SprayTech Corporation (SprayTech), is warranted against defects in material and workmanship for one (1) year following date of purchase if operated in accordance with SprayTech's printed recommendations and instructions.

For SprayTech EP and GP (piston) sprayers: In addition, for SprayTech models EP2100, EP2300 and EP2510 SprayTech warrants non-wear parts of the fluid section, drive train and mechanical pressure control components against defects in material and workmanship for two (2) years from the date of purchase. For SprayTech models EP2505, GP2605, GP2905 SprayTech warrants non-wear parts of the fluid section, speed reducer, drive train and electronic pressure control components, transducer and circuit board against defects in material and workmanship for three (3) years from the date of purchase. SprayTech warrants the electric motor or gasoline engine for all piston models (EP and GP sprayers) against defects in material and workmanship for two (2) years from the date of purchase.

For SprayTech ED or GD (diaphragm) series sprayers: In addition, SprayTech warrants the diaphragm for the lifetime of the sprayer against defects in material and workmanship; and warrants the electric motor for three (3) years from the date of purchase.

Within the applicable warrant period, SprayTech will repair or replace, at our option, defective parts without charge if such parts are returned with transportation charges prepaid to the nearest Authorized Service Center or to SprayTech Corporation, 1770 Fernbrook Lane, Minneapolis, MN 55447. If SprayTech is unable to repair this product as to conform to this Limited Warranty after a reasonable number of attempts, SprayTech will provide, at our option, either a replacement for this product or a full refund of the purchase price of this product. *These remedies are the sole and exclusive remedies available for breach of express and implied warranties.*

What is Not Covered By This Warranty:

1. This Warranty does not cover any defects or damages caused by either:
 - a) the use or installation of repair or replacement parts or accessories not manufactured by SprayTech, or
 - b) repair performed by anyone other than a SprayTech Authorized Service Center.
2. The Warranty does not cover equipment and accessories supplied to SprayTech from an original equipment manufacturer, including but not limited to: hoses, tips, or accessories. SprayTech will provide the purchaser with copies of the original equipment manufacturer's express warranties provided to SprayTech along with the name and address of the appropriate manufacturer.
3. This Warranty does not cover damage or defects caused by or related to abrasion, corrosion, abuse, misuse, negligence, accident, normal wear, faulty installation or tampering in a manner which impairs normal operation.

Limitation of Remedies:

IN NO CASE SHALL SPRAYTECH BE LIABLE FOR ANY INCIDENTAL, SPECIAL OR CONSEQUENTIAL DAMAGES OR LOSS, INCLUDING TRANSPORTATION COSTS, WHETHER SUCH DAMAGES ARE BASED UPON A BREACH OF EXPRESS OR IMPLIED WARRANTIES, BREACH OF CONTRACT, NEGLIGENCE, STRICT TORT, OR ANY OTHER LEGAL THEORY.

Disclaimer Of Implied Warranties:

THE FOREGOING WARRANTIES ARE IN LIEU OF ALL OTHER WARRANTIES, EXPRESS OR IMPLIED, INCLUDING BUT NOT LIMITED TO THE IMPLIED WARRANTIES OF MERCHANTABILITY AND FITNESS FOR A PARTICULAR PURPOSE.

No Ability To Transfer:

This warranty is extended to the original purchaser only and is not transferable.

Your Rights Under State Law:

Some states do not allow limitations on how long an implied warranty lasts or the exclusion of incidental or consequential damages, so the above limitation and exclusion may not apply to you. This warranty gives you specific legal rights, and you may also have other rights which vary from state to state.

Tough Customer™

To validate the Tough Customer™ Program, the completed Tough Customer card included with each sprayer must be mailed immediately. (In the event you did not receive a Tough Customer™ registration card with your sprayer, call 1-800-292-4637, or write us at the address below). The return of this card is not required for you to exercise your rights under the limited warranty.

SprayTECH.
1770 Fernbrook Lane
Minneapolis, Minnesota 55447
Telephone 1-800-292-4637