

Agilent U1051A Time to Digital Converter

Application Note - Absolute Time Recovery

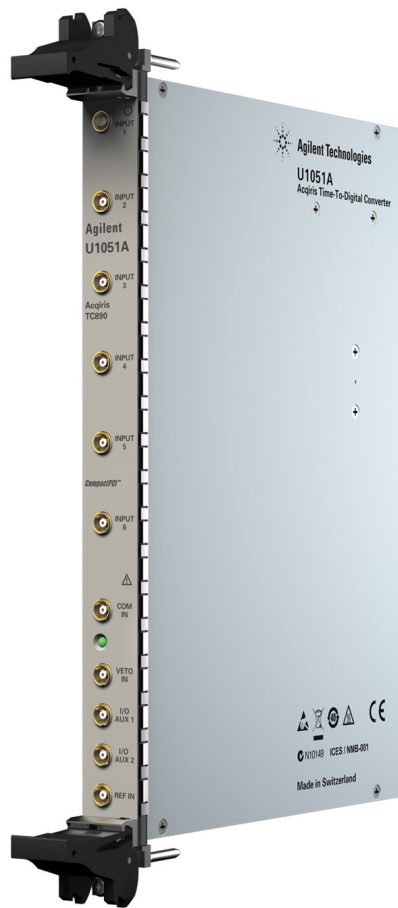

Agilent Technologies

Notices

© Agilent Technologies, Inc. 2012

No part of this manual may be reproduced in any form or by any means (including electronic storage and retrieval or translation into a foreign language) without prior agreement and written consent from Agilent Technologies, Inc. as governed by United States and international copyright laws.

Manual Part Number U1092-90055

Edition

Edition 1.0, 24 July 2012

Printed in USA

Agilent Technologies, Inc.

Sales and Technical Support

To contact Agilent for sales and technical support, refer to the “support” links on the following Agilent web resources:

- www.agilent.com/find/U1051A
(product-specific information and support, software and documentation updates)
- www.agilent.com/find/cPCI
- www.agilent.com/find/Assist
(worldwide contact information for repair and service)

Warranty

The material contained in this document is provided “as is,” and is subject to being changed, without notice, in future editions. Further, to the maximum extent permitted by applicable law, Agilent disclaims all warranties, either express or implied, with regard to this manual and any information contained herein, including but not limited to the implied warranties of merchantability and fitness for a particular purpose. Agilent shall not be liable for errors or for incidental or consequential damages in connection with the furnishing, use, or performance of this document or of any information contained herein. Should Agilent and the user have a separate written agreement with warranty terms covering the material in this

document that conflict with these terms, the warranty terms in the separate agreement shall control.

Safety Notices

Refer to the safety notices included in the specific product StartUp Guide or User Manual.

Front and Rear Panel Symbols:



The CE mark is a registered trademark of the European Community.



The C-Tick mark is a registered trademark of the Australian Spectrum Management Agency.



This symbol indicates product compliance with the Canadian Interference-Causing Equipment Standard (ICES-001). It also identifies the product is an Industrial Scientific and Medical Group 1 Class A product (CISPR 11, Clause 4).



This symbol indicates separate collection for electrical and electronic equipment, mandated under EU law as of August 13, 2005. All electric and electronic equipment are required to be separated from normal waste for disposal (Reference WEEE Directive, 2002/96/EC).



This symbol on an instrument means caution, risk of danger. You should refer to the operating instructions located in the user documentation in all cases where the symbol is marked on the instrument.



This symbol indicates the time period during which no hazardous or toxic substance elements are expected to leak or deteriorate during normal use. Forty years is the expected useful life of the product.



This symbol indicates the instrument is sensitive to electrostatic discharge (ESD). ESD can damage the highly sensitive components in your instrument. ESD damage is most likely to occur as the module is being installed or when cables are connected or disconnected. Protect the circuits from ESD damage by wearing a grounding strap that provides a high resistance path to ground. Alternatively, ground yourself to discharge any built-up static charge by touching the outer shell of any grounded instrument chassis before touching the port connectors.



This symbol denotes a hot surface. The side cover of the module will be hot after use and should be allowed to cool for several minutes.

Abstract

This document describes the methodology to utilize the Agilent (Acqiris) U1051A Time to Digital Converter (TDC) module in applications requiring absolute time measurements beyond the range of the module. The TDC module is a precise event counter with 50 ps timing precision. The module, however, has a limitation in that the counter circuitry in the module resets every 10.48 milliseconds (or more precisely 10.48576 ms). This poses a problem in applications requiring longer capture times beyond this time window. This document, however, describes a method to allow users to take advantage of the modules speed, precision, and channel count to extend the capabilities to virtually any event time measurement application.

Background

For a detailed description of the theory of operation of the U1051A TDC module refer to the User's Manual for the module which may be obtained at <http://www.agilent.com/find/U1051A> along with other documentation and resources for this module.

Figure 1 (below) shows a simplified block diagram of the TDC module. The module incorporates 6 input channels and a Common channel used for external trigger/start operation.

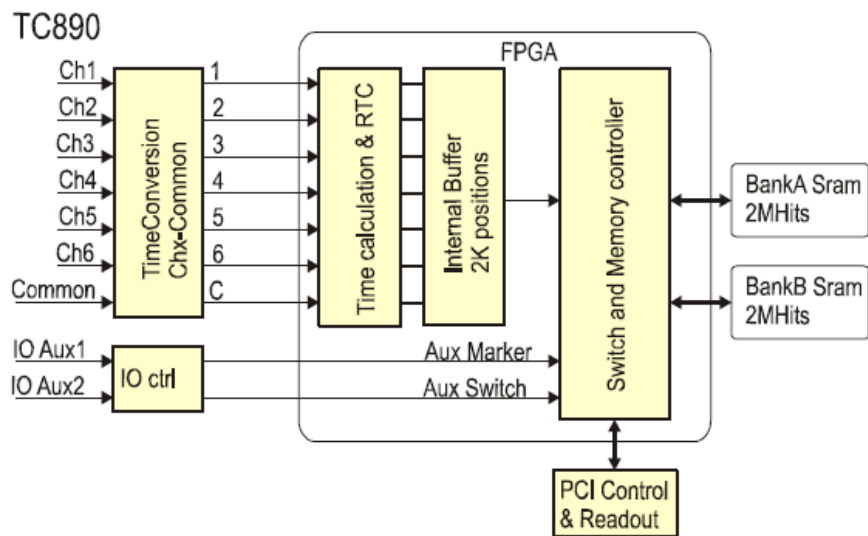

Figure 1 - U1051A (TC890) Simplified block diagram

Measured events from the channels are stored into a dual-bank memory structure and are read out upon a memory bank switch event. There are multiple methods of bank switching the memory prior to system readout. This document will outline two methodologies that can be utilized to perform a bank switch operation:

1. Memory-based Setting
2. Number of Common Events.

The key thing to note about the TDC module is that all events are stored in memory in the order that they are received. Thus when events are time-tagged and subsequently

read out of the module, they will form an array of time tag events in order of their input event time. Additionally, when an event is stored into memory, a flag is set for that entry denoting which channel (1-6) is associated with the event.

The Limitation

The key limitation of the TDC module is that it is essentially a counter that resets to zero every 10.48576 ms, thus all events measured by the module will have a time tag event between 0 and 10.48576. This can cause confusion and problems for longer duration measurements. For example, say that you are measuring a 3 ms clock period on channel 1 of the TDC module and that you have started the TDC module with a hardware trigger synchronized to your 3 ms clock. If you read the first 4 entries of data on channel 1 you would obtain the following:

3.000 ms, 6.000 ms, 9.000 ms, 2.51424 ms (to 50 ps precision)

The first three values make sense but the fourth does not. What has happened is that the TDC module has reset (or rolled back to 0) between the third and fourth measurement.

This issue poses two problems. First, recovering the absolute time of the fourth and subsequent events will require accounting for this 10.48576 ms roll. Second, if events are infrequent (> 10.48576 ms) when we read out the event times there will be an ambiguity of whether the event occurred in the next counter roll or some subsequent counter roll.

The Solution

Figure 2 below shows how the TDC module resets to 0 every 10.48576 ms. To address the ambiguity issue of ensuring that we have an event within every counter roll cycle, it is necessary to provide a periodic clock event that is less than the 10.48 ms counter roll period. We recommend using a 100 Hz clock signal into one of the TDC input channels. The 100 Hz clock signal equates to a 10 ms period which will ensure that an event is measured on every clock cycle.

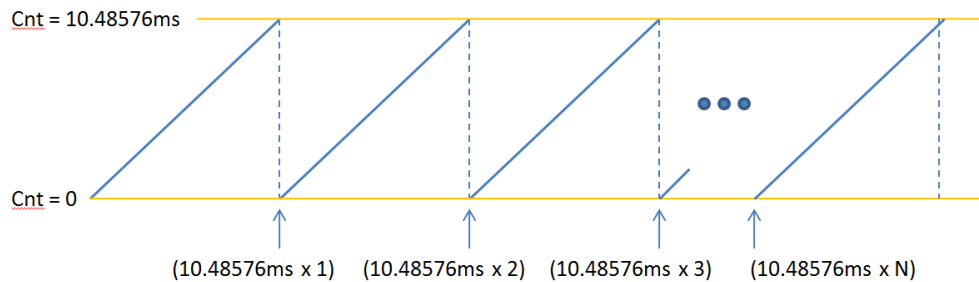

Figure 2 - TDC counter cycle

For purposes of our discussion, we will assume the user has provided a 100 Hz (10 ms) clock signal into the Channel 6 input of the TDC module. In Figure 3 below channel 6 events are shown in green. Notice that since the 10 ms clock event is less than (and not fundamentally related to) the clock roll interval, that the CH6 events occur earlier and earlier in each subsequent counter roll. The time period between CH6 events we

know will be 10 ms. This now becomes our absolute time clock counter event. Eventually as shown on the right of Figure 3 (below), there will be times when two CH6 events are measured in the same counter roll cycle. This won't pose a problem in recovering absolute time.

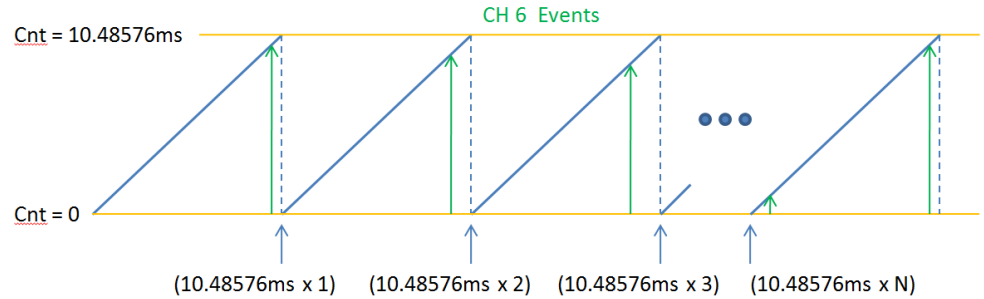

Figure 3 - Channel 6 Events

Next, we will examine how to correct for absolute time for any and all events collected regardless of when they occurred.

To aid implementation of software control of the TDC module, example programs are provided by Agilent covering several different programming environments. These example programs cover the basic control of the module including module setup and reading of data. These examples and a Programmer's Manual are available from Agilent.com website. These basic examples can be easily augmented with software to perform the absolute time recovery mentioned in this application note.

Acquisition Method 1 Memory-based bank switch

This method of TDC acquisition calls for the user to set the amount of memory used in the acquisition. When the set number of events is written into memory, then the TDC will switch memory banks to allow users to read out the data of the prior memory bank and begin acquiring data into the second bank. This capability allows the TDC module to continuously and seamlessly acquire data events indefinitely. (Note: Continuous and gap-free operation will be maintained as long as events can be written out of the memory bank prior to the TDC module bank-switching back to this memory. Refer to the TDC module User Guide for rate transfer information).

In Figure 4 (below) we will look at an example measurement and how we can implement a correction routine to deal with the counter rolls.

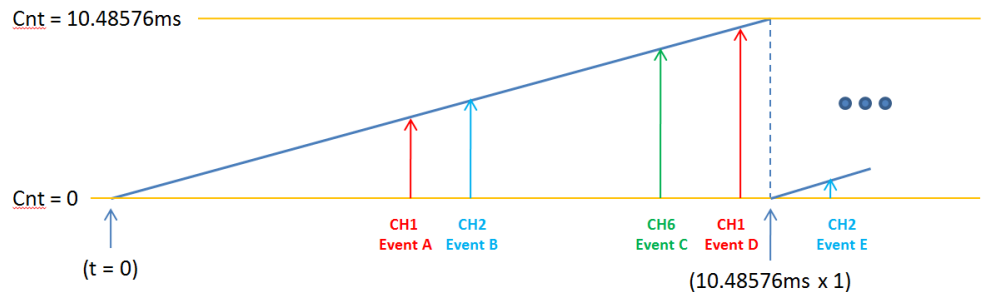

Figure 4 - Example measurement, events A - E

In this case we are looking at the first set of event data that was retrieved from the

module, and these initial events occurred right at the beginning of acquisition on the first counter cycle. In this example we will look at 5 measured events (A through E) as shown on the diagram above. The measured data might look like this:

Ch 1 Event - A	4.123 ms
Ch 2 Event - B	5.123 ms
Ch 6 Event - C	8.454 ms
Ch 1 Event - D	10.123 ms
Ch 2 Event - E	0.345 ms

Here we see that we have two measurement channel events (1 and 2) followed by a CH6 (100 Hz clock) event followed by two additional channel events (1 and 2) and the last event has occurred on the next counter roll cycle.

This acquisition was performed using a software trigger to start acquisition so that the start time of acquisition ($t=0$) is independent of the CH6 clock. Events A through D all occur on the first counter cycle and between events D and E, the TDC module has rolled to the next counter cycle.

Next, we will examine how to process measurement data to recover the absolute event time at any arbitrary point in the collected data.

In this example, we're looking at arbitrary events collected by the TDC module. For this process to work the user needs to collect and keep track of the following information.

1. The initial event time of the first CH6 clock entry
2. The number of CH6 events that have occurred

With these two pieces of information we can stitch together an accurate time axis for the data. In the Figure 5 (below) we have another scattering of events.

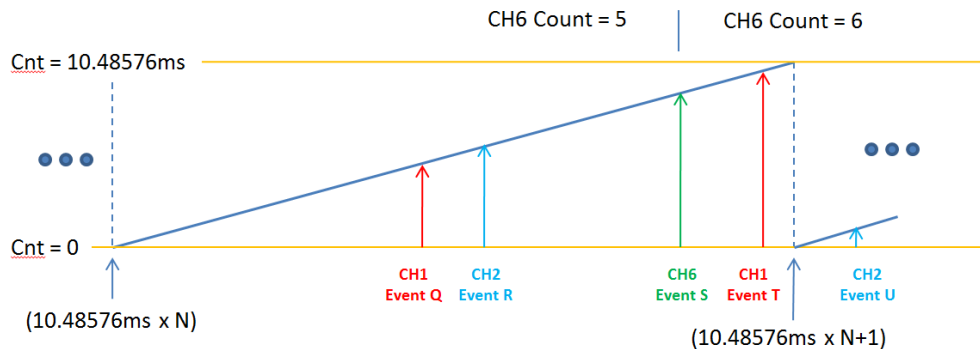

Figure 5 - Example measurement, events Q - U

As we read events Q through U out of memory, they will be read out in this order:

Ch 1 Event - Q	4.123 ms
Ch 2 Event - R	5.123 ms
Ch 6 Event - S	8.454 ms
Ch 1 Event - T	10.123 ms
Ch 2 Event - U	0.345 ms

Here we see two channel events Q and R occurring on one given counter cycle followed by a CH6 clock event on the same cycle then another CH1 event T on the

same cycle. Finally event U occurs on the following counter cycle. Just examining the data you can see that a counter roll has occurred because Event U has a smaller value than event T. Note also that up until Event S we had a stored CH6 count of 5 events and after event S we now have a count of 6 CH6 events.

Recovering the absolute time of all events is now a two part process. First we need to determine a Raw Absolute Time which equates to the most recent CH6 event time. To do this we can use the following formula:

Formula 1

$$\text{Raw Absolute Time} = \text{CH6Count} \times 10.48576 + \text{CH6EventTime}$$

So for events Q and R above, the CH6 count is 5. We would also have the first CH6 event time from our earlier data thus we can calculate the Raw Absolute time. For event T we would have a CH6 count of 6 along with the event time of the first CH6 event to properly anchor the Raw Absolute Time (which matches the exact time at Event S).

The Raw Absolute Time is merely the exact time of each CH6 time event. Next, we need to account for the time difference from other channel measured events to the previous CH6 absolute time. This is done with the following 2 formulas:

If ($\text{CHx_EventTime} > \text{MostRecentCH6EventTime}$) then we are on the same ramp cycle, Then:

Formula 2a

$$\text{Abs Event Time} = \text{RawAbsTime} + \text{CHx_EventTime} - \text{MostRecentCH6EventTime}$$

Event T above meets this criterion. Its event time is greater than the most recent CH6 event time (since it is higher on the cycle). Therefore, to determine Event T's absolute time we take the Raw Absolute Time calculated earlier and add in the difference from the current event T minus the last CH6 event time.

Next, if the event time for the channel is less than the most recent CH6 event time then we use this formula:

If ($\text{CHx_EventTime} < \text{MostRecentCH6EventTime}$) then we are on the next ramp cycle and we need to factor in the 10.48576 ms thus:

Formula 2b

$$\text{Abs Event Time} = \text{RawAbsTime} + 10.48576 \text{ ms} - \text{MostRecentCH6EventTime} + \text{CHx_EventTime}$$

Event U above meets this criterion. It has a smaller value in time (relatively speaking) than the Event time S so we know that a counter roll has occurred. Therefore, we need to take the Raw Absolute Time (at Event S) and add in the full counter time of 10.48576 ms minus the most recent CH6 event time, and then we need to add in the measured channel event time. This would provide the absolute time at Event U.

Acquisition Method 2

Number of common events
bank switch

This method of TDC acquisition calls for the user to apply the 100 Hz clock signal (10 ms) into the Common Input of the TDC module instead of one of CH6. The TDC module is then configured to bank switch on N cycles of the COM input. This is simply an alternate operating mode of the TDC module. Refer to Figure 6 (below) for this mode.

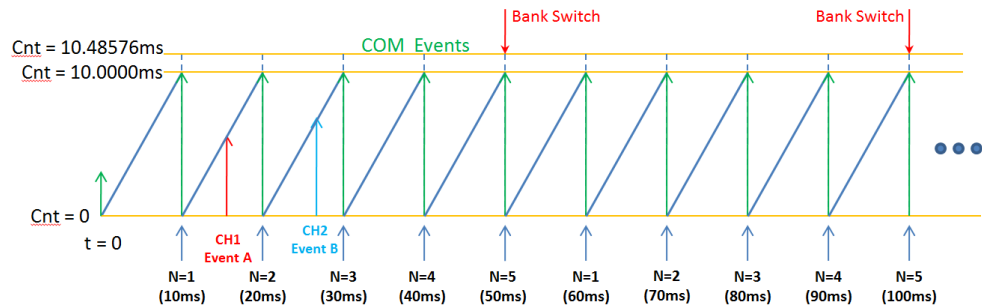

Figure 6 - Acquisition method 2

Notice that now the first pulse of the 100 Hz clock signal will begin TDC acquisition at $t=0$. Every time a COM input fires (10 ms) the TDC time is reset back to 0. This eliminates having to deal with the counter roll phenomenon because we are never allowing the TDC to go beyond 10 ms. It also dramatically simplifies recovering the absolute time.

In this example N is set to 5 which means that every 5th clock cycle of the 100 Hz clock (or 50 ms in total) the TDC module will perform a memory bank switch and allow the data from the previous bank to be read out. Thus memory bank switches occur every 5th COM input (50 ms) while the TDC module time is reset on every COM input (10 ms). This makes it easier to deal with reconstructing the time axis so this acquisition method has this advantage. The disadvantage of this mode is that if the number of events that come in within the time window (of 50 ms) exceeds the maximum memory of the memory bank, then events will be lost.

Let's look at our example above and the data that was collected:

COM Event - 1	0 ms (abs time 10 ms)
CH1 Event - A	5.458 ms
COM Event - 2	0 ms (abs time 20 ms)
CH2 Event - B	3.123 ms
COM Event - 3	0 ms (abs time 30 ms)
COM Event - 4	0 ms (abs time 40 ms)
COM Event - 5	0 ms (abs time 50 ms)

Here we see mostly a set of COM (Common) events that are read. Each COM input resets the TDC time to 0 thus we only need to count the number of COM events that have occurred and multiply it by our 10 ms to achieve our starting reference time or Raw Absolute Time.

Formula 3

$$\text{Raw Absolute Time} = \text{COM_Count} \times 10.000 \text{ ms}$$

So for our example Event A has occurred after the 10 ms start point so we need to only add in the measured event time for Event A (5.458 ms) and add it to 10 ms for an

absolute time of 15.458 ms for Event A. Again, the TDC time is reset to 0 for every COM input, and our COM input rate is 10 ms (or less than the max value of 10.48576 ms) thus:

Formula 4

$$Abs\ Event\ Time = Raw\ Absolute\ Time + CHx_EventTime$$

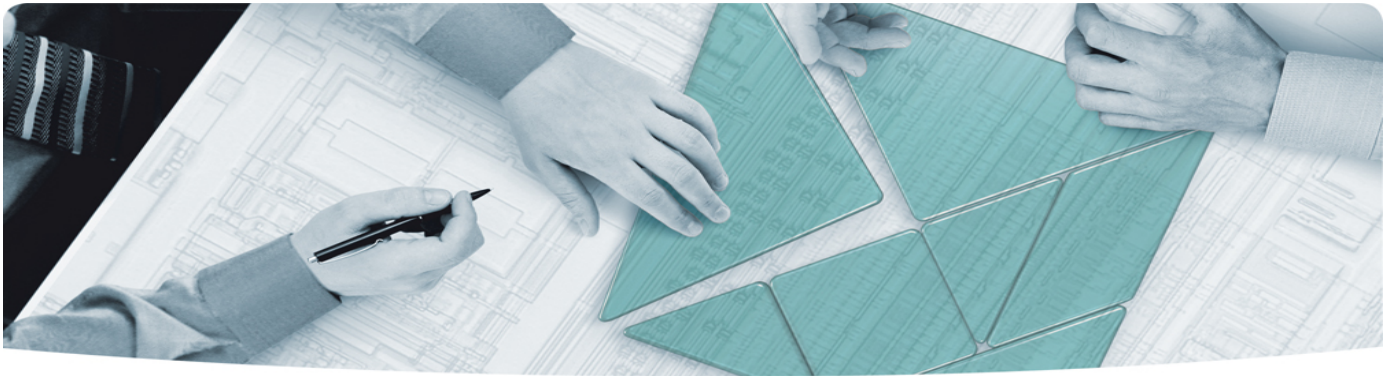

The Modular Tangram

The four-sided geometric symbol that appears in Agilent modular product literature is called a tangram. The goal of this seven-piece puzzle is to create shapes—from simple to complex. As with a tangram, the possibilities may seem infinite as you begin to create a new test system. With a set of clearly defined elements—hardware, software—Agilent can help you create the system you need, from simple to complex.



DISCOVER the Alternatives ...

... Agilent **MODULAR** Products



Agilent Advantage Services is committed to your success throughout your equipment's lifetime.
www.agilent.com/find/advantageservices



Agilent Email Updates keep you informed on the latest product, support and application information.
www.agilent.com/find/emailupdates



Agilent Channel Partners provide sales and solutions support. For details, see
www.agilent.com/find/channelpartners

Agilent Electronic Measurement Group



ISO 9001:2008 certified. For details, see
www.agilent.com/quality

PXI www.pxisa.org

AXIe www.axistandard.org

PICMG and the PICMG logo, CompactPCI and the CompactPCI logo, AdvancedTCA and the AdvancedTCA logo are US registered trademarks of the PCI Industrial Computers Manufacturers Group. "PCIe" and "PCI EXPRESS" are registered trademarks and/or service marks of PC-SIG. Microsoft, Windows, Visual Studio, Visual C++, Visual C#, and Visual Basic are either registered trademark or trademarks of Microsoft Corporation.

Product descriptions in this document are subject to change without notice.

© Agilent Technologies, Inc. 2012

www.agilent.com

www.agilent.com/find/modular

www.agilent.com/find/embedded

For more information on Agilent Technologies' products, applications or services, please contact your local Agilent office. (For additional listings, go to www.agilent.com/find/assist.)

Americas

Canada	(877) 894 4414
Brazil	(11) 4197 3500
Mexico	01800 5064 800
United States	(800) 829 4444

Asia Pacific

Australia	1 800 629 485
China	800 810 0189
Hong Kong	800 938 693
India	1 800 112 929
Japan	0120 (421) 345
Korea	080 769 0800
Malaysia	1 800 888 848
Singapore	1 800 375 8100
Taiwan	0800 047 866
Thailand	1 800 226 008

Europe & Middle East

Austria	43 (0) 1 360 277 1571
Belgium	32 (0) 2 404 93 40
Denmark	45 70 13 15 15
Finland	358 (0) 10 855 2100
France	0825 010 700 (0.125 €/minute)
Germany	49 (0) 7031 464 6333
Ireland	1890 924 204
Israel	972 3 9288 504 / 544
Italy	39 02 92 60 8484
Netherlands	31 (0) 20 547 2111
Spain	34 (91) 631 3300
Sweden	0200 88 22 55
Switzerland	0800 80 53 53
United Kingdom	44 (0) 118 9276201