

IPC Series

PANECON-PC
IPC-PT/H620X(PCW) Series,
IPC-PT/L620S(PCW) Series
User's Manual

CONTEC CO.,LTD.

Copyright

Copyright 2004 CONTEC CO., LTD. ALL RIGHTS RESERVED

No part of this document may be copied or reproduced in any form by any means without prior written consent of CONTEC CO., LTD.

CONTEC CO., LTD. makes no commitment to update or keep current the information contained in this document.

The information in this document is subject to change without notice.

All relevant issues have been considered in the preparation of this document. Should you notice an omission or any questionable item in this document, please feel free to notify.

CONTEC CO., LTD.

Regardless of the foregoing statement, CONTEC assumes no responsibility for any errors that may appear in this document or for results obtained by the user as a result of using this product.

Trademarks

Intel and Celeron are registered trademarks of Intel Corporation. MS, Microsoft and Windows are trademarks of Microsoft Corporation. Other brand and product names are trademarks of their respective holder.

Table of Contents

Copyright	i
Trademarks	i
Table of Contents	ii

1. INTRODUCTION 1

Features	1
Compatible Operating Systems	1
Customer Support	2
Web Site	2
Limited One-Year Warranty	2
How to Obtain Service	2
Liability	2
Safety Precautions	3
Safety Information	3
Handling Precautions	3

2. OVERVIEW 7

Specifications	7
System Configuration	11
Physical Dimensions	12

3. HARDWARE SETUP 15

Before Using the PANECON-PC for the First Time	15
Hardware Setup	16
Removing the Top Cover and HDD Bracket	16
Locations and Settings of Internal Connectors and Jumpers	17
Installing the Hard Disk	19
Installing the Main Memory (DIMM)	20
Fastening the Power Cable	22
Installation Procedure	24
Installation Requirements	25

4. BIOS SETUP 27

Starting the Setup Screen	27
Keystrokes	27
Main Menu	28
Boot Features Window	29
Advanced Window	30
I/O Device Configuration Window	32

ISA Bridge Window	33
Security Window	34
Power Window	35
PC-Health Window	36
Boot Window	37
Exit Window	38

5. EACH COMPONENT FUNCTION	39
-----------------------------------	-----------

Component Identification	39
Line in Interface.....	41
Line out Interface.....	41
MIC input Interface	41
Keyboard Interface	42
Mouse Interface	42
Serial Port Interface	43
Floppy Disk Interface	51
USB Ports	52
Ethernet.....	53
PC Card Slots.....	54
DVI Interface	55
Printer Port Interface	57
RAS Functions.....	58
Watchdog Timer	59
General-purpose I/O and Remote Reset.....	63
S1	67
Reset Switch	67
IDE Interface	68
Expansion Slots (CP Model)	70

6. TOUCH PANEL	75
-----------------------	-----------

Touch panel serial interface.....	75
-----------------------------------	----

7. APPENDIX	77
--------------------	-----------

Memory Map	77
I/O Port Addresses.....	78
Interrupt Level List.....	79

8. LIST OF OPTIONS	81
---------------------------	-----------



1. Introduction

This IBM PC/AT compatible panel computer incorporates a touch panel and uses the Ultra Low Voltage Intel(R) Celeron(R) Processor 400MHz CPU for low power consumption. The computer is aimed at industrial applications and can operate using natural ventilation only (without a fan).

Equipped with assorted interfaces such as the USB, 100BASE-TX, and RS-232C ports, the IPC-PT/x620x(PCW) can serve for a wide range of applications as an information terminal based on an OS for general-purpose PCs. Through careful selection of components including adopting an embedded-type CPU and chipset, the computer has an excellent level of resistance to environmental conditions and is suitable for long-term operation. This makes it a safe choice for use in rugged environments such as FA applications.

The PANECON-PC 620 series is available in the following four models:

Base Model

IPC-PT/L620S(PCW)C	(TFT color 12.1 inch type)
IPC-PT/H620X(PCW)C	(TFT color 15 inch type)

Model with Expansion Slot

IPC-PT/L620S(PCW)CP	(TFT color 12.1 inch type)
IPC-PT/H620X(PCW)CP	(TFT color 15 inch type)

Features

- Equipped with the Ultra Low Voltage Intel(R) Celeron(R) Processor 400MHz (FSB 100MHz) CPU and memory conforming 256MB as standard
- Fan-less operation achieved by natural air-cooling
- High reliability and completely silent running (when fitted with the silicon disk from CONTEC)
- Long, reliable supply (The CPU and chip set are embedded versions.)
- Adoption of BIOS (Phoenix Technologies, Ltd.) customized by CONTEC to support the BIOS level
- Other than the conforming PC I/F, equipped with the PCMCIA (for CardBus), Audio (AC97 conforming), 100BASE-TX and RAS I/F as a standard
- Equipped with a secondary-IDE connector to allow an optional external CD-ROM to be connected
- Capable of starting up, even with the battery dead, using CMOS data retained by EEPROM
- Front part is the ingress protection for IP65 performance

Compatible Operating Systems

- Windows 2000 Professional
- Windows NT Workstation 4.0(SP6a)
- Windows XP Embedded
- Windows NT Embedded 4.0

Customer Support

CONTEC provides the following support services for you to use CONTEC products more efficiently and comfortably. No driver software is provided with this module. Please download the latest drivers from the CONTEC web site. Documents including important notes on the use of the module are also posted on the web site. Please visit the CONTEC web site before using the module.

Web Site

Japanese <http://www.contec.co.jp/>
English <http://www.contec.com/>
Chinese <http://www.contec.com.cn/>

Latest product information

CONTEC provides up-to-date information on products.

CONTEC also provides product manuals and various technical documents in the PDF.

Free download

You can download updated driver software and differential files as well as sample programs available in several languages.

Note! For product information

Contact your retailer if you have any technical question about a CONTEC product or need its price, delivery time, or estimate information.

Limited One-Year Warranty

CONTEC Products are warranted by CONTEC CO., LTD. to be free from defects in material and workmanship for up to one year from the date of purchase by the original purchaser.

Repair will be free of charge only when this device is returned freight prepaid with a copy of the original invoice and a Return Merchandise Authorization to the distributor or the CONTEC group office, from which it was purchased.

This warranty is not applicable for scratches or normal wear, but only for the electronic circuitry and original products. The warranty is not applicable if the device has been tampered with or damaged through abuse, mistreatment, neglect, or unreasonable use, or if the original invoice is not included, in which case repairs will be considered beyond the warranty policy.

How to Obtain Service

For replacement or repair, return the device freight prepaid, with a copy of the original invoice. Please obtain a Return Merchandise Authorization Number (RMA) from the CONTEC group office where you purchased before returning any product.

*No product will be accepted by CONTEC group without the RMA number.

Liability

The obligation of the warrantor is solely to repair or replace the product. In no event will the warrantor be liable for any incidental or consequential damages due to such defect or consequences that arise from inexperienced usage, misuse, or malfunction of this device.

Safety Precautions

Understand the following definitions and precautions to use the product safely.

Safety Information

This document provides safety information using the following symbols to prevent accidents resulting in injury or death and the destruction of equipment and resources. Understand the meanings of these labels to operate the equipment safely.

⚠ DANGER	DANGER indicates an imminently hazardous situation which, if not avoided, will result in death or serious injury.
⚠ WARNING	WARNING indicates a potentially hazardous situation which, if not avoided, could result in death or serious injury.
⚠ CAUTION	CAUTION indicates a potentially hazardous situation which, if not avoided, may result in minor or moderate injury or in property damage.

Handling Precautions

⚠ WARNING

- Always check that the power supply is turned off before connecting or disconnecting power cables.
- Do not use the touch panel to control operations that have the potential to cause serious injury or death.
- Do not modify the product.
- Always turn off the power before inserting or removing circuit boards or cables.
- This product is not intended for use in aerospace, space, nuclear power, medical equipment, or other applications that require a very high level of reliability. Do not use the product in such applications.
- If using this product in applications where safety is critical such as in railways, automotive, or disaster prevention or security systems, please consult with your sales agent or CONTEC information service.
- Do not attempt to replace the battery as inappropriate battery replacement poses a risk of explosion.
- For battery replacement, contact your retailer as it must be performed as a process of repair.
- When disposing of a used battery, follow the disposal procedures stipulated under the relevant laws and municipal ordinances.

⚠ CAUTION

- Do not use or store the product in a location such as extremely high or low temperature, rapid temperature changes, and the place which receives a strong ultraviolet ray.
Example:
 - Exposure to direct sun
 - In the vicinity of a heat source
- Do not use the product in extremely humid or dusty locations. It is extremely dangerous to use the product with its interior penetrated by water or any other fluid or conductive dust. If the product must be used in such an environment, install it on a dust-proof control panel, for example.
- Avoid using or storing the device in locations subject to shock or vibration.
- Do not use the product in the vicinity of devices that generate strong magnetic force or noise. Such devices will cause this device to malfunction.
- Do not use or store the product in the presence of chemicals.
- The lower center of the left face (seen from the connector's front surface) may become hot. To avoid being burned, do not touch that section while the product is in operation or immediately after turning off the power. Avoid installation in a location where people may come into contact with that section.
- To clean the PANECON-PC, wipe it gently with a soft cloth dampened with either water or mild detergent. Do not use chemicals or a volatile solvent, such as benzene or thinner, to prevent peeling or discoloration of the paint.
- 2.5 inches hard disk drive (HDD) of our company has not guaranteed use by continuation and continuation power for 24 hours. When it is used by continuation operation and continuation power a life fails extremely. In the case of a 24-hours operation system, use of our company silicon disk drive (SDD) is recommended.
- Before installing or uninstalling an expansion board (the P model) or connecting or disconnecting a connector, be sure to unplug the power cable from the wall outlet.
- CONTEC reserves the right to refuse to service a product modified by the user.
- In the event of failure or abnormality (foul smells or excessive heat generation), unplug the power cord immediately and contact the sales representative you purchased the product from or the CONTEC Information Center.
- Use an AC cable that is compatible with both the rated supply voltage and the receptacle. (The cable provided with the product is for 125VAC.)
- Do not use any sharp-pointed object such as a mechanical pencil to touch the touch panel. Doing so may scratch the touch panel, resulting in malfunctions.
- Do not subject the touch panel to shock as doing so may break it.
- When the surface or frame of the touch panel has become dirty, wipe it with neutral detergent. Do not wipe the touch panel with thinner, alcohol, ammonia, or a strong chlorinated solvent. Use a protective sheet (available as an option) if the touch panel is used where it can easily collect dust and dirt.
- A characteristic of analog touch panels is that the detected position may vary due to changes in the ambient environment (temperature and humidity) and changes in resistance values over time. In such cases, the touch panel should be recalibrated and the calibration data updated.
- To connect with peripherals, use a grounded, shielded cable.

- Hard disks have a limited life span. Please perform systematic backup and maintenance.
- CONTEC does not provide any guarantee for the integrity of data on hard disks.
- To prevent corruption of files, always shutdown the OS before turning off the PANECON-PC.
- LCD displays may develop small regions that are always illuminated or always dark. Also, color irregularities may be apparent from certain viewing angles. However, these are due to the nature of the LCD display and do not represent a fault.

Burn-in on TFT Display

- "Burn-in" may occur if the same display is retained for a long time. Avoid this by periodically switching the display so that the same display is not maintained for a long time.
 - * Burn-In: Phenomenon characterized by a TFT display as a result of long-time display of the same screen where a shadow-like trace persists because electric charge remains in the LCD element even after the patterns are changed.

Component Life

1. Power supply--- Estimated life is about 10 years based on continual operation at 40°C (horizontal installation). However, (higher) operating temperatures will result in shorter life.
 2. Battery--- The internal calendar clock and CMOS RAM are backed by a Lithium primary battery. The backup time at a temperature of 25°C with the power disconnected is 10 years or more.
 3. LCD backlight--- Display brightness decreases over time with use. The operating lifetime of the backlight is as follows (the time until the brightness is lowered to 50% of the initial value):
 - IPC-PT/L620S(PCW) : 50,000 hours
 - IPC-PT/H620X(PCW) : 25,000 hours
 4. Touch panel--- The operating lifetime of the touch panel is at least 1 million touches (as tested by mechanical touching under 300 g of force at a rate of two presses per second).
- * Replacement of expendables is handled as a repair (there will be a charge).
 - Regarding "VCCI Class A, FCC PART 15 Class A and EMC Instruction Class A Notice"

The ferrite core must be installed in the following each cable so that this product (IPC-PT/L620S(PCW)C, IPC-PT/L620S(PCW)CP only) may suit the above-mentioned standard.

 - Speaker connection cable
 - Optional Ferrite Core (FRC2009A-6) or SEIWA E04SR200935A (or an equivalent product)

Open the ferrite core case and wind the cable around it once near the connector and close it.

- Image diagram

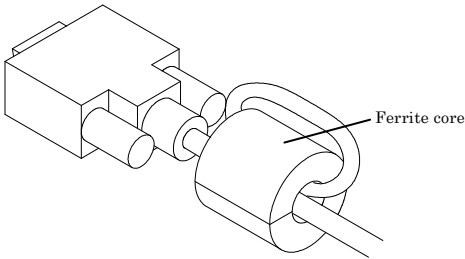

Moreover, the screw to install "AC cord metal brace" (Refer to P.22) should be grounded as countermeasure against static electricity.

FCC PART 15 Class A Notice (IPC-PT/L620S(PCW)C, IPC-PT/L620S(PCW)CP only)

NOTE

This equipment has been tested and found to comply with the limits for a Class A digital device, pursuant to part 15 of the FCC Rules. These limits are designed to provide reasonable protection against harmful interference when the equipment is operated in commercial environment. This equipment generates, uses, and can radiate radio frequency energy and, if not installed and used in accordance with the instruction manual, may cause harmful interference to radio communications. Operation of this equipment in a residential area is likely to cause harmful interference at his own expense.

WARNING TO USER

Change or modifications not expressly approved the manufacturer can void the user's authority to operate this equipment.

2. Overview

Specifications

Table 2.1. Functional Specifications < 1 / 2 >

Model		IPC-PT/L620S(PCWC)	IPC-PT/L620S(PCWC)CP	IPC-PT/H620X(PCWC)	IPC-PT/H620X(PCWC)CP
Display	LCD type	12.1-inch TFT color LCD, SVGA (800 x 600 dots)		15-inch TFT color LCD, XGA (1024 x 768 dots)	
	Number of colors	260,000			
Touch panel	Resolution	4096 x 4096 (emulated in 800 x 600 mode)		4096 x 4096 (emulated in 1024 x 768 mode)	
	Detection method	Analog resistive			
Backlight ON/OFF		Enabled (software control)			
CPU		Ultra Low Voltage Intel(R) Celeron(R) Processor 400MHz, FSB100MHz			
Chip set		Intel(R) 815E			
Memory	L2 Cache	256KB			
	Main memory	256 MB standard *1 / Max. 256MB (3.3V 144pin SO-DIMM PC133 Socket x 2)			
	BIOS ROM	128KB E0000H · FFFFFFFH (Phoenix)			
Video	Controller	Intel 815E (Built into the controller)			
	Video RAM	Main memory shared			
	Video BIOS	48KB (C0000H · CBFFFF)			
	Display I/F	DVI-I 29pin *2			
Audio		AC97 compliant LINE IN: ϕ 3.5 Stereo mini jack Full-scale input level 1.3Vrms(Typ.) LINE OUT: ϕ 3.5 Stereo mini jack Full-scale input level 1.0Vrms(Typ.) MIC UN: ϕ 3.5 monaural mini jack Full-scale input level 1.3Vrms(Typ.)			
FDD I/F		Equipped with a dedicated 26pin, half-pitch connector: 2 modes (Optional FDD: PC-FDD25BH)			
IDE HDD I/F	Primary	Ultra DMA/100 22.5 inch IDE HDD or silicon disk drive: 1 internal unit (One more unit can be added. Either of the two must be a silicon disk drive.)			
	Secondary	Equipped with a dedicated 40pin, half-pitch connector (for connection of an optional CD-ROM) (bottom)			
Serial I/F		RS-232C(general-purpose): 2ch (SERIAL PORT1, 2) 9pin, D-SUB connector RS-232C(touch panel): 1ch (SERIAL PORT3) RS-422/485(general-purpose): 1ch (SERIAL PORT4) [inside the RAS connector]			
Parallel I/F		Bi-directional, Centronics-compliant, 25pin D-SUB connector			
LAN	I/F	Ethernet 100BASE-TX/10BASE-T RJ-45 connector			
	Controller	Intel ICH2 integrated			
PC card slot		PCMCIA Type I, II x 2 or III x 1 (Startup from ATA card not allowed) CardBus correspondence			

Table 2.1. Functional Specifications < 2 / 2 >

Model	IPC-PT/L620S(PCW)C	IPC-PT/L620S(PCW)CP	IPC-PT/H620X(PCW)C	IPC-PT/H620X(PCW)CP	
RAS function	WDT: 1sec - 255sec (RESET or external output is allowed at time expiration) Remote reset: External input signal				
Expansion board slot	None	PCI/ISA shared *3 slot x 2, Installable board length : 240mm (Max.)	None	PCI/ISA shared *3 slot x 2, Installable board length : 240mm (Max.)	
RTC/CMOS	Lithium backup battery life: 10 years or more				
Power supply	Input supply voltage	Automatically switched between 85 - 132 VAC and 170 - 265 VAC (47 - 63 Hz)			
	Current consumption	60VA (Max.)	110VA (Max.)	65VA (Max.)	115VA (Max.)
	Expansion board power supply capacity	None	+5V: 2A (1A x 2 Slot), -5V: Not supplied, +12V: 0.3A, -12V: 80mA	None	+5V: 2A (1A x 2 Slot), -5V: Not supplied, +12V: 0.3A, -12V: 80mA
Physical dimensions (mm)	370(W) x 79(D) x 307(H) (Board depth)	370(W) x 139(D) x 307(H) (Board depth)	428(W) x 79(D) x 336(H) (Board depth)	428(W) x 139(D) x 336(H) (Board depth)	
Waterproofing, dustproofing	IP65, front				
Weight	Approx. 6.6kg	Approx. 7.5kg	Approx. 7.6kg	Approx. 8.5kg	

*1 A 256 MB memory module is plugged in one socket.

*2 Using the DVI-analog RGB adapter (accessory bundled), one more unit of an ordinary analog RGB input display can be added. Note that Panel Link input displays cannot be connected.

*3 The following signals cannot be used on ISA bus slots.

-5V, IOCHK, REFRESH, MASTER

The PCI bus slots comply with the 32-bit specification. Use of combined 32/64-bit boards has not been verified.

Table 2.2. Installation Environment Requirements

Parameter		Requirement description
USB I/F	2ch (USB 1.1)	
Keyboard I/F	PS/2-type keyboard-compatible (6pin, MINI DIN connector)	
Mouse I/F	PS/2-type mouse-compatible (6pin MINI DIN connector)	
RAS function	WDT: 1sec to 255sec (RESET or external output is allowed at time expiration) Remote reset: External input signal	
Power supply specifications	Allowable instantaneous	Less than 20ms
	Power outage	One minute each for 3.0 kVAC (input-output), 2.0 kVAC (input-FG), and 0.5 kVAC (output-FG)
	Dielectric strength	50MΩ (500VDC)
Ambient specifications	Operating temperature	
	0 · 50°C(SDD in use)	
	5 · 45°C(HDD in use)	
	5 · 45°C(FDD in use)	
	Storage temperature	
	-10 · 60°C	
	Humidity *1	
	10 · 90%RH(No condensation)	
	Floating dust particles	
	Not to be excessive	
Corrosive gases		
None		
Line-noise resistance	Line noise	AC line/±2kV, Signal line/±1kV (IEC1000-4-4Level 3, EN61000-4-4Level 3)
	Static electricity resistance	Contact discharge/±4kV (IEC1000-4-2Level 2, EN61000-4-2Level 2) Atmospheric discharge/±8kV (IEC1000-4-2Level 3, EN61000-4-2Level 3)
Vibration resistance *2	Sweep resistance	10 · 57Hz/semi-amplitude 0.15mm 57 · 150Hz/2.0G 80 min. each in x, y, and z directions (JIS C0040-compliant, IEC68-2-6-compliant)
	Impact resistance *2	10G, half-sine shock for 11 ms in x, y, and z directions (JIS C0041-compliant, IEC68-2-27-compliant)
Grounding		Class D grounding (previous class 3 grounding)

*1 When a floppy disk is not in use.

*2 When the HDD and FDD are not in use.

Display Optical Specifications

Table 2.3. IPC-PT/L620S(PCW)C, IPC-PT/L620S(PCW)CP

Parameter	Condition		Min.	Typical	
View angle (Vertical)	CR≥10	$\phi = 180^\circ$	Display. Monochrome	35deg	45deg
		$\phi = 0^\circ$		45deg	55deg
View angle (Horizontal)		$\phi = +90^\circ$	me	50deg	60deg
		$\phi = -90^\circ$		50deg	60deg
Contrast	Display. Monochrome		150	-	
Brightness (at center)	Display. White		240cd/m ²	300cd/m ²	

Table 2.4. IPC-PT/H620X(PCW)C, IPC-PT/H620X(PCW)CP

Parameter	Condition		Min.	Typical	
View angle (Vertical)	CR≥10	$\phi = 180^\circ$	Display. Monochrome	-	45deg
		$\phi = 0^\circ$		-	55deg
View angle (Horizontal)		$\phi = +90^\circ$	me	-	60deg
		$\phi = -90^\circ$		-	60deg
Contrast	Display. Monochrome		200	350	
Brightness (at center)	Display. White		200cd/m ²	250cd/m ²	

$$\text{Contrast ratio (CR)} = \frac{\text{Brightness at screen center with white displayed}}{\text{Brightness at screen center with black displayed}}$$

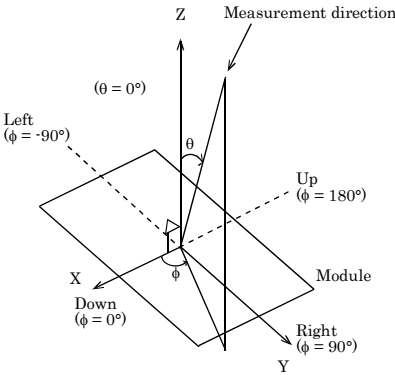

Figure 2.1. Display Optical Specifications

System Configuration

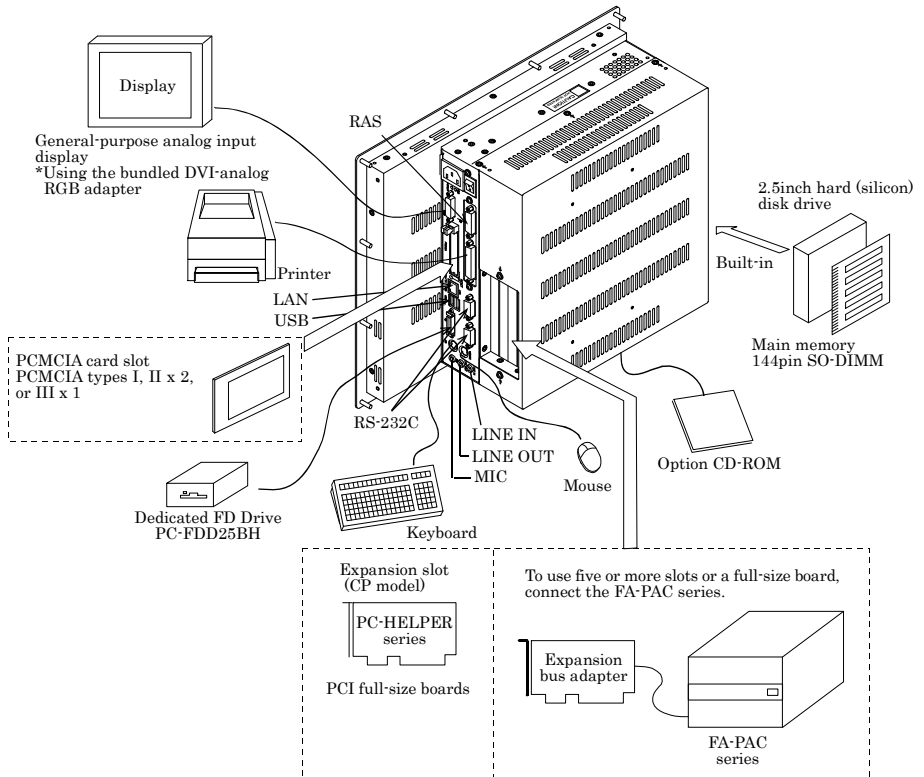

Figure 2.2. System Configuration

Physical Dimensions

IPC-PT/L620S(PCW)C

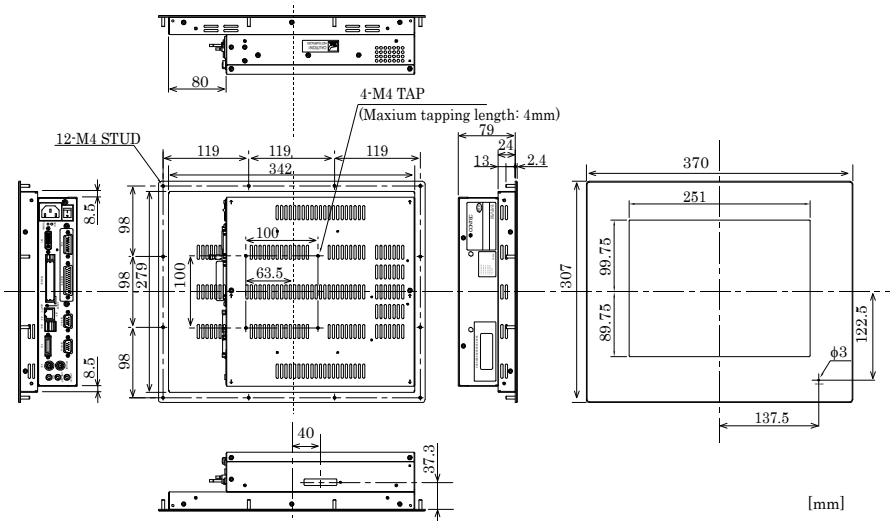

Figure 2.3. IPC-PT/L620S(PCW)C

IPC-PT/L620S(PCW)CP

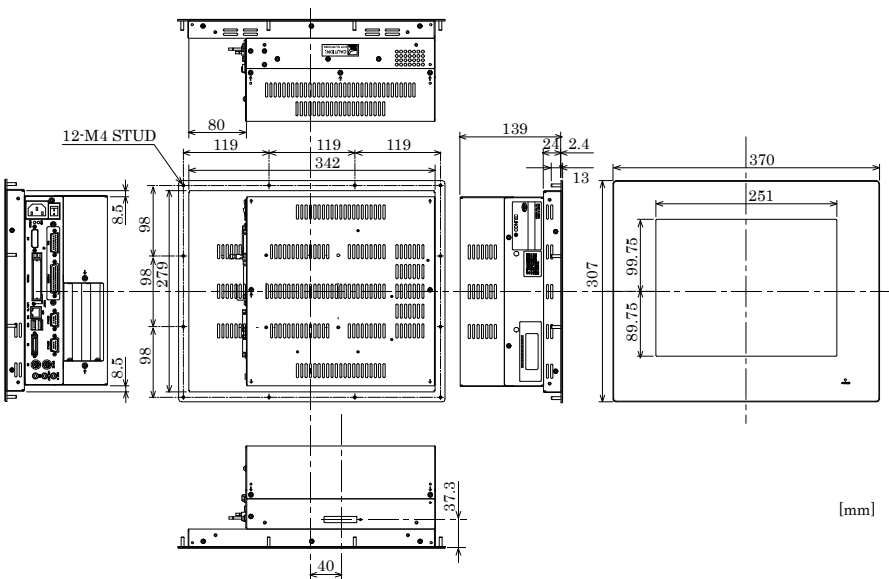

Figure 2.4. IPC-PT/L620S(PCW)CP

IPC-PT/H620X(PCW)C

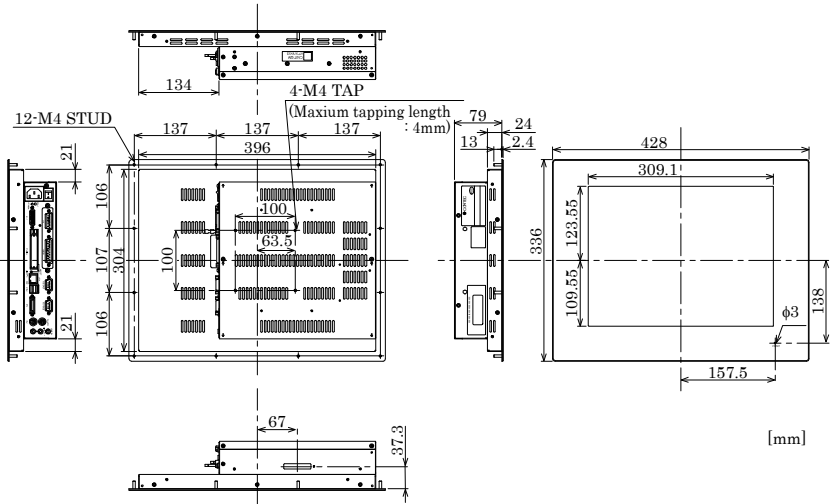

Figure 2.5. IPC-PT/H620X(PCW)C

IPC-PT/H620X(PCW)CP

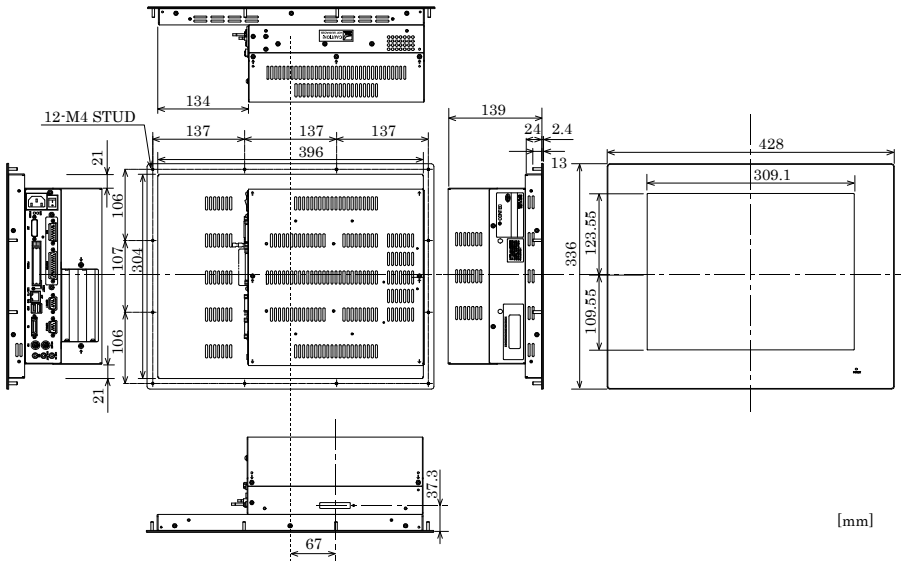

Figure 2.6. IPC-PT/H620X(PCW)CP

3. Hardware Setup

Before Using the PANECON-PC for the First Time

Follow the next steps to set up the PANECON-PC:

- STEP1 Install the hard disk and expansion main memory (DIMM) and set jumper switches. By referring to the information in this chapter, set the PANECON-PC.
- STEP2 Connect cables.
Connect necessary external devices, such as a printer and a CRT, to the PANECON-PC using appropriate cables.
- STEP3 Turn on the power.
After verifying that you have correctly followed steps 1 and 2, turn on the power. If you feel something is wrong after turning on the power, turn off the power immediately and check to see if the PANECON-PC has been set up correctly.
- STEP4 Set up BIOS.
By referring to Chapter 4, set up BIOS. This setup requires a keyboard and a display.
* Before using the PANECON-PC, be sure to execute "LOAD SETUP DEFAULTS" to initialize the BIOS settings to their default values.
(See Chapter 4, "Main Menu.")



CAUTION

If your PANECON-PC is an OS preinstalled model, be sure to connect the keyboard and mouse to it before turning the power on for the first time.

Hardware Setup

Removing the Top Cover and HDD Bracket

- Before you start, be sure that the power is turned off.
- Remove only those screws that are explained. Do not move any other screw.

(1) Remove the top cover.

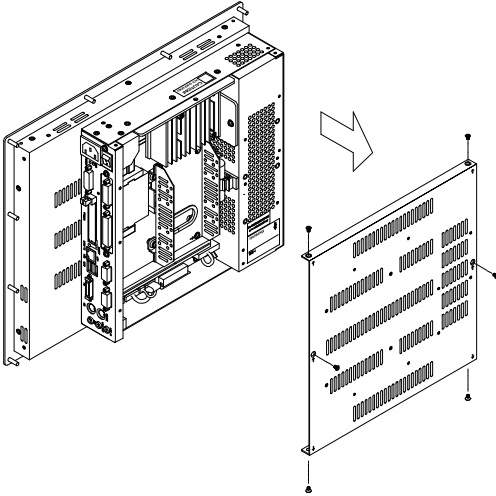

Figure 3.1. Removing the Top Cover

(2) Remove the hard disk bracket.

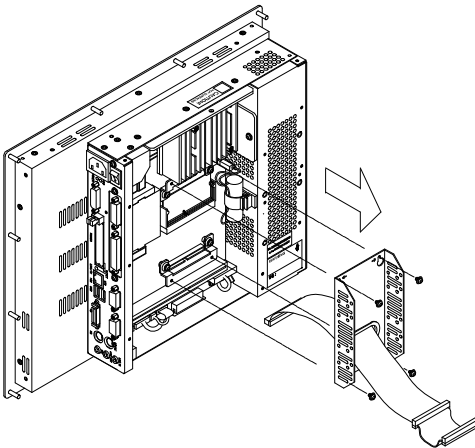

Figure 3.2. Removing the HDD Bracket

Locations and Settings of Internal Connectors and Jumpers

When you remove the top cover and hard disk bracket, the connectors, jumpers, and switches are laid out as shown in the figure below:

IPC-PT/L620S(PCW)C,
IPC-PT/L620S(PCW)CP

IPC-PT/H620X(PCW)C,
IPC-PT/H620X(PCW)CP

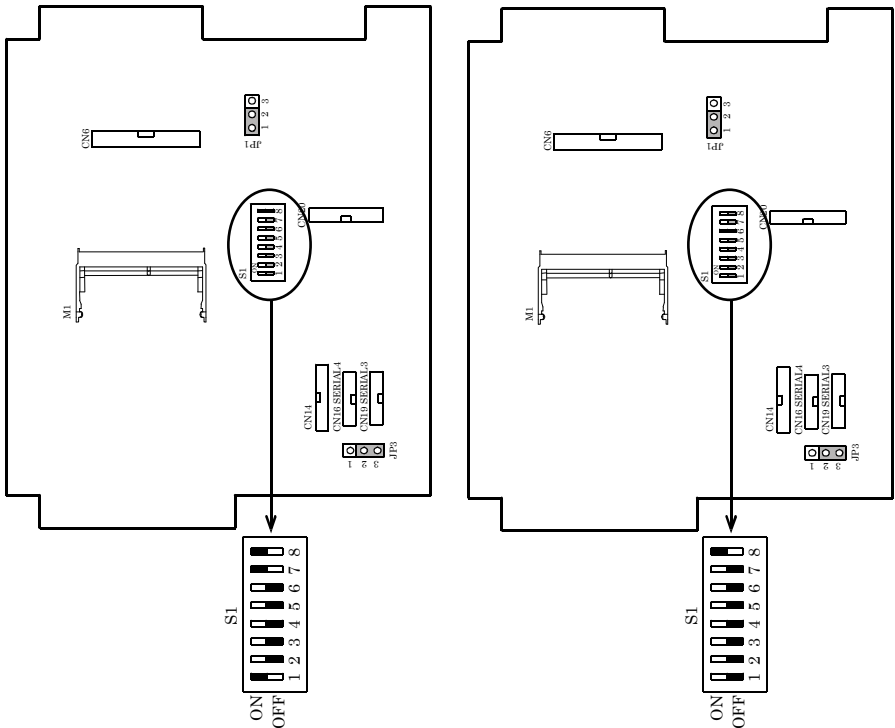

Figure 3.3. Locations and Settings of Jumpers, Connectors, and Switches inside the Top Cover (IPC-PT/L620S(PCW)C, IPC-PT/L620S(PCW)CP, IPC-PT/H620X(PCW)C, IPC-PT/H620X(PCW)CP)

Table 3.1. Jumper List

No.	Function	Factory setting		Reference Page	Remarks
		IPC-PT/L620S(PCW)C IPC-PT/L620S(PCW)CP	IPC-PT/H620XS(PCW)C IPC-PT/H620X(PCW)CP		
JP1	Clear CMOS.	1 - 2 shorted	1 - 2 shorted	----	Short 2-3 to clear CMOS.
JP3	Sets RS-485 termination	2 - 3 shorted	2 - 3 shorted	45	
S1	Used by the system	2,3,4,5,6 OFF 1,7,8 ON	1,2,3,4,5,6,7 OFF 8 ON	67	Leave this jumper as factory-set.

Table 3.2. Internal Connector List

Name	v	Reference page
CN15	Primary IDE connector (44pin, pin header)	68
M1	Expansion memory set (3.3V, 144pin SO-DIMM)	20
CN20	Printer Connector	57
CN14	RAS Connector	58

Installing the Hard Disk

- (1) Connect the provided HDD cable to the hard disk (silicon disk).

⚠ CAUTION

Connect the HDD cable in alignment with pins from the left end of the connector on the HDD side.

Four master/slave setting pins are left unconnected on the right side. Be aware that connecting the power with the connector misaligned will damage the cable.

- (2) By threading the cable through the hole on the base of the hard disk bracket, fasten the disk to its bracket using four screws.

- Fasten the disk using the outer or inner hole depending on the model you are using. (The figure below shows an example that uses the inner screw hole.)

⚠ CAUTION

When installing two drives in the HDD bracket, you can place either the hard disk drive (HDD) or silicon disk drive (SDD) in the upper position and only the SDD in the lower position. If you install two disk drives, set their jumpers according to the instructions in their manuals to assign them as the master and slave devices.

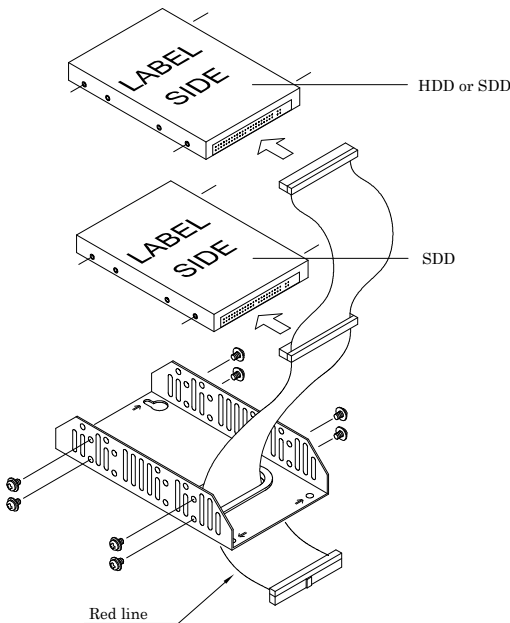

Figure 3.4. Installing the Hard Disk

- (3) Connect the HDD cable to CN6 on the unit and fasten the hard disk bracket to the unit using four screws.
- (4) Close the top cover and secure it with screws.

Installing the Main Memory (DIMM)

Compatible DIMM Types

Obtain the following special option products.

- Package type : 144pin Small Outline DIMM
- Specifications : 3.3V, PC133/CL3
- Capacity : 256MB
- Type : SDRAM
- Optional memories * : PC-MSD256-144V

- Package type : 144pin Small Outline DIMM
- Specifications : 3.3V, PC100/CL2
- Capacity : 128MB
- Type : SDRAM
- Optional memories * : PC-MSD128-144H

*Operation is not guaranteed if memory parts other than CONTEC option products are used.

Main Memory (DIMM) Installation Procedure

The mounted SO-DIMM sockets vary depending on the type of the circuit board used.

<Board type with single sockets on its front and back>

This type of circuit board has single sockets on its front and back. The socket on the back is equipped with standard memory. To add more memory, install it to the socket on the front of the board.

Follow the next steps to fit the memory into the SO-DIMM socket:

- (1) Insert the DIMM into its socket with the notch positioned on the right side. (See the note.)

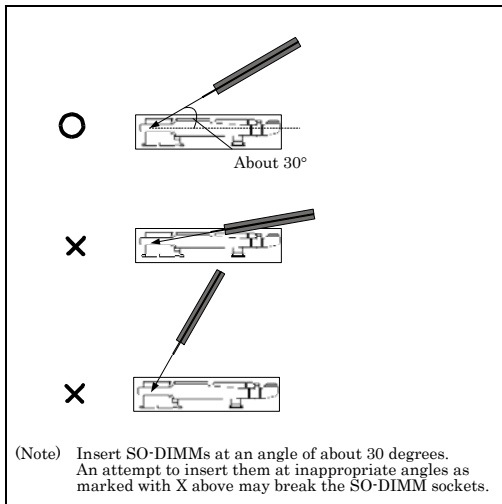
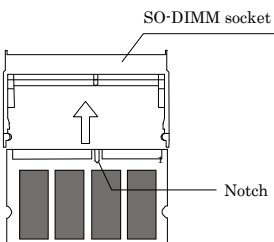

(2) Press in the direction indicated by the arrow. You hear a click as the memory fits into the socket.

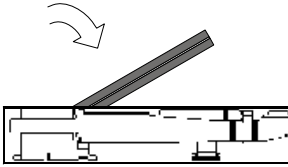

Figure 3.5. Installing the SO DIMM

<Board type with a double socket on its front>

This product has a double socket on the front of its circuit board. Standard memory is installed in the lower socket. To add more memory, install it to the upper socket.

SO-DIMM Disconnection Procedure

Open the levers on both sides slightly to the left and right. You should be able to remove the DIMM.

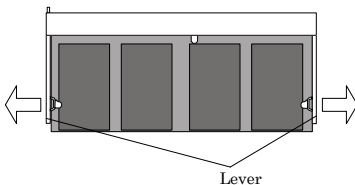

Figure 3.6. Uninstalling the SO-DIMM

⚠ CAUTION

The SO DIMM socket plugging/unplugging life is 30 times. The operation of an SO DIMM socket is not guaranteed once an SO DIMM has been plugged and unplugged more than 30 times.

Fastening the Power Cable

Removing the Screw on the Metal Brace to Keep the AC Cord in Place

In order to install the metal brace, temporarily remove the machine screw on the front left end.

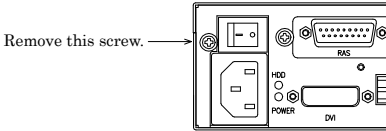

Figure 3.7. Removing the Screw

Installing the AC Cord Metal Brace and the Clamp

Insert the AC cord all the way into the inlet. Fasten the AC cord metal brace using the screw you removed earlier. Attach the clamp to an appropriate location on the metal brace to clamp the cord. The "AC cord metal brace" is attached to the main case.

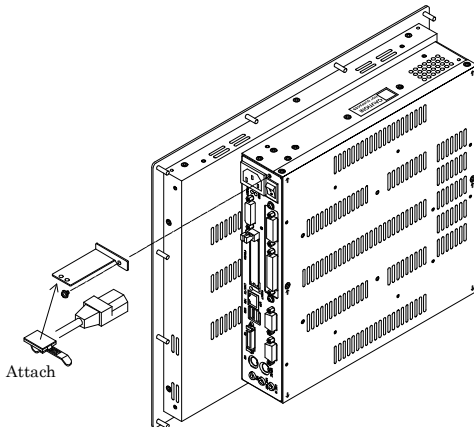

Figure 3.8. Installing the AC Cord Metal Brace and the Clamp

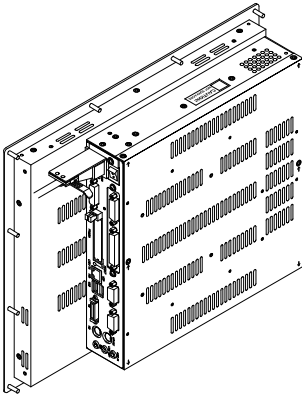

Figure 3.9. Installing the Metal Brace and the Clamp

Installation Procedure

(1) Cut a panel in the following dimensions for installing the main unit.

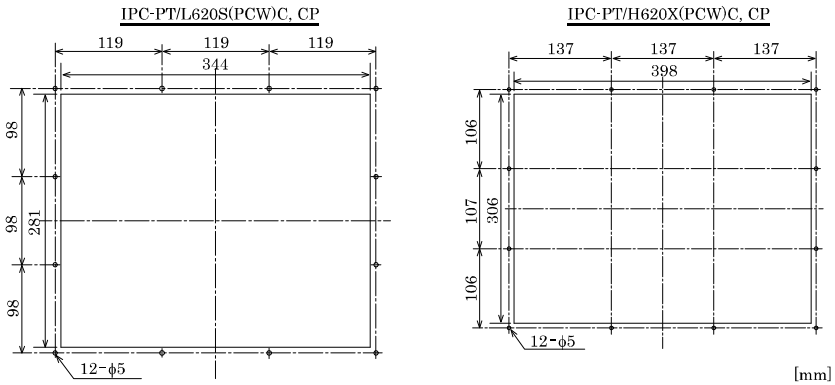

Figure 3.10. Panel Opening Dimensions

(2) Insert the supplied gasket between the panel and display and fasten them together with M4 nuts as shown below.

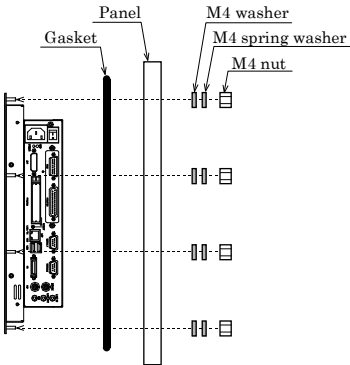

Figure 3.11. Assembling Method

Installation Requirements

To restrict overheating, always mount the unit vertically. Similarly, to maintain the ambient temperature within the range specified in the specifications, ensure a clearance between the unit and surrounding equipment of at least 100mm for the top and rear and 50mm for the bottom and sides.

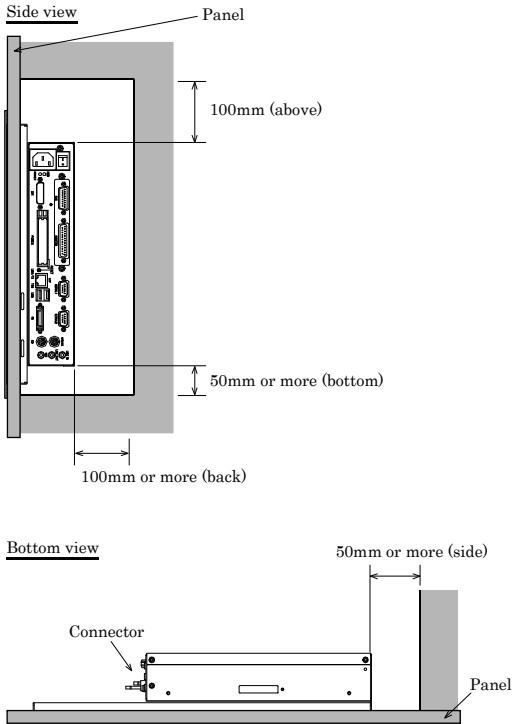

Figure 3.12. Distances between the PANECON-PC and Its Vicinity

4. BIOS Setup

BIOS setup sets various settings during startup. When using the system for the first time, be sure to run BIOS setup. Once set up, the specified details will be backed up.

Starting the Setup Screen

When you turn on the system power supply, the PANECON-PC displays the following initial screen as long as the system is normal. Press the <F2> key at the keyboard.

```

Phoenix BIOS 4.0 Release 6.0
Copyright 1985-2001 Phoenix Technologies Ltd.
All Rights Reserved

Copyright 2001, CONTEC CO., Ltd.
IPC-BX/M620(PCW), IPC-Px/x620(PCW) series BIOS Ver. x.xx.
CPU = Celeron(TM) Tualatin 256K-ULP (100MHz/0.95V)*processor 400MHz
Memory Speed = PC100
635K System RAM Passed
509M Extended RAM Passed
512K Cache SRAM Passed
System BIOS Shadowed
Video BIOS shadowed

```

Figure 4.1. Initial Screen

Keystrokes

The following is a list of major key functions you can use during BIOS setup:

Table 4.1. Key Function List

Key to press	Function
→, ←	Moves the main menu.
↑, ↓	Moves between items to be set.
<Tab>	Moves within items to be set.
<Shift>+<Tab>	Moves in the direction opposite to <Tab>.
<Spacebar>	Changes details to be set.
+	Functions the same as <Spacebar>.
-	Changes in the direction opposite to the + key.
<Enter>	Opens submenus.
<Esc>	Moves to the Exit window.
<F9>	Resets all to defaults.
<F10>	Saves set values and exits setup.

Main Menu

PhoenixBIOS Setup Utility		Item Specific Help
Main	Advanced Security Power PC_Health Boot Exit	
System Time:	[00:55:20]	<Tab>, <Shift-Tab>, or <Enter> selects field
System Date:	[09/05/2002]	
Legacy Diskette A:	[1.44/1.25 MB 3 ¹ / ₂ "]	
▶ Primary Master	[No device]	
▶ Primary Slave	[No device]	
▶ Secondary Master	[No device]	
▶ Secondary Slave	[No device]	
▶ Boot Features		
System Memory:	640 KB	
Extended Memory:	521728 KB	
F1 Help	↑↓ Select Item -/+ Change Values	F9 Setup Defaults
Esc Exit	←→ Select Menu Enter Select ▶ Sub-Menu	F10 Save and Exit

Figure 4.2. Main Window (Factory Settings)

- System Time** : Sets the time on the equipment calendar clock.
- System date** : Sets the date on the equipment calendar clock.
- Legacy Diskette A** : Specify the type of FDD to be used as drive A. If you are not using the FDD, set to "Disabled." Select: Disabled / 360K, 5.25in. / 1.2M, 5.25in. / 720K, 3.5in. / 1.44M, 3.5in / 2.88M, 3.5in.
- Primary Master** : Set the type of HDD(SDD) to be used as the first drive. Selecting this field changes the screen to the submenu for manually setting drive configuration data such as the number of cylinders. This field is set to [Auto] by default. You can leave it intact for normal use.
- Primary Slave** : Set the type of HDD(SDD) to be used as the second drive. Selecting this field changes the screen to the submenu for manually setting drive configuration data such as the number of cylinders. This field is set to [Auto] by default. You can leave it intact for normal use.
- Secondary Master** : Normally, connection is not allowed. Set this field if you have connected a CD-ROM drive to the secondary IDE connector.
- Secondary Slave** : Connection not allowed. Set to "None."
- Boot Features** : This field launches the Boot Features submenu to enable or disable the options for checking the floppy disk drive and keyboard upon system boot. (See Boot Features Windows.)
- System Memory** : Displays the detected amount of memory installed on the system.
- Extended Memory** : Displays the detected amount of memory installed on the system.

Boot Features Window

PhoenixBIOS Setup Utility	
Main	
Boot Features	Item Specific Help
Floppy check : [Disabled]	
Keyboard check : [Disabled]	
F1 Help ↑ ↓ Select Item -/+ Change Values F9 Setup Defaults Esc Exit ← → Select Menu Enter Select ► Sub-Menu F10 Save and Exit	

Figure 4.3. Boot Features Window (Factory Settings)

- Floppy check : Select whether to seek the FDD for a connection check during system boot-up. If no FDD has been connected with this field set to [Enabled], the BIOS suspends system boot-up with an error message displayed.
- Keyboard check : Select whether to seek the FDD for a connection check during system boot-up. If no FDD has been connected with this field set to [Enabled], the BIOS suspends system boot-up with an error message displayed. Connect the keyboard, then recycle the power supply.

Advanced Window

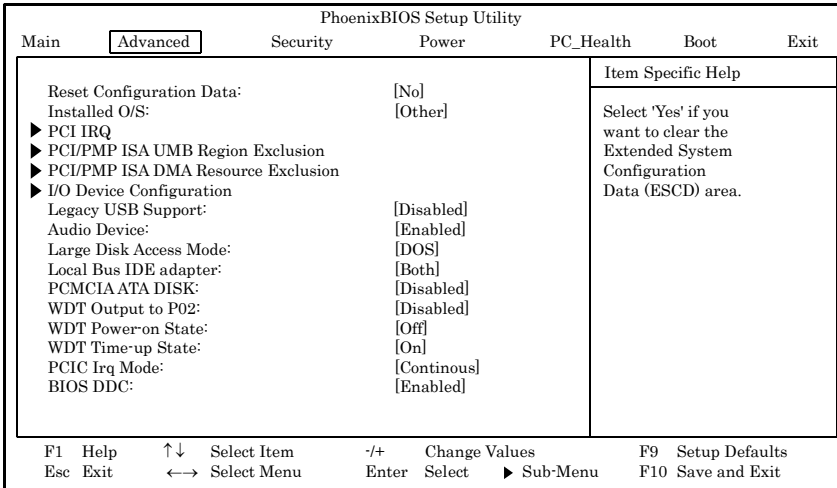

Figure 4.4. Advanced Window (Factory Settings)

Reset Configuration Data: Resets the system configuration data stored in BIOS ROM. The data will be reset by setting this field to [Yes] and exiting BIOS Setup while saving the changes you made. This field reverts to [No] automatically the next time you invoke BIOS Setup. Before reinstalling the OS, be sure to set the field to [Yes].

Installed OS: Normally, set to "Other."

PCI IRQ: Displays the PCI IRQ setup submenu. You can assign IRQs to individual PCI slots. All PCI slots are connected to IRQ10 by default.

PCI/PNP ISA UMB Region Exclusion: Start PCI/PNP ISA UMB Region Exclusion as shown above. You can reserve UMB areas for devices. All UMB areas are unallocated by default. Up to 32 kilobytes from addresses D0000 - D7FFFH can be allocated.

PCI/PNP ISA DMA Resource Exclusion: Start PCI/PNP ISA DMA Resource Exclusion as shown above. You can reserve DMA channels for devices. All UMB areas are unallocated by default.

I/O Device Configuration: Start I/O Device Configuration as shown above. You can configure serial and parallel ports. (See I/O Device Configuration Window.)

ISA Bridge	Sets up ISA bus expansion slots.
Legacy USB Support	: Emulates the USB keyboard, mouse, and FDD as legacy devices. Set this field to [Enabled] before installing the OS using the USB keyboard. Once the OS gets up and running, the keyboard is controlled by the OS's driver and this field need not be set to [Enabled]. Leave the field set to [Disabled] for normal use.
Audio Device	: Enable or disable the AC97 device.
Large Disk Access Mode	: Normally, set to " DOS."
Local Bus IDE adapter	: Specify whether to enable or disable IDE device.
PCMCIA ATA DISK	: Setting for the ATA CARD booting. Use it the [Disabled] in the default.
WDT Output to PO2	: Set the watchdog timer output to PO2.
WDT Power-on State	: With the watchdog timer output to PO2 enabled, set the output status in the power-on state.
WDT Time-up State	: With the watchdog timer output to PO2 enabled, set the output status in the Time-up state.
PCIC Irq Mode	: Set to " Continuous ".
BIOS DDC	: Specify whether to enable or disable DDC. Please set to [Enabled].
Start Wait	: Sets the wait time for the startup of BIOS and enables timing adjustment for devices connected to the main unit. [Disabled], [5sec], [10sec], [15sec], [20sec], [25sec], or [30sec] can be selected. When [Disabled] is selected, there is no wait time. (It means the same as "0sec".) Select [Disabled] under normal conditions, which is the default setting.

I/O Device Configuration Window

PhoenixBIOS Setup Utility		
Advanced		
I/O Device Configuration	Item Specific Help	
Serial Port A : [Enabled]	Configure port using options:	
Base I/O address : [3F8]		
Interrupt : [IRQ 4]		
Serial port B : [Enabled]		[Disabled]
Base I/O address : [2F8]		No configuration
Interrupt : [IRQ 3]		
Serial port C : [Enabled]		[Enabled]
Base I/O address : [3F8]		User configuration
Interrupt : [IRQ 5]		
Serial port D : [Enabled]		
Base I/O address : [2E8]		
Interrupt : [IRQ 11]		
Parallel port : [Enabled]		
Mode : [ECP]		
Base I/O address : [378]		
Interrupt : [IRQ7]		
DMA channel : [DMA3]		
Floppy disk controller : [Enabled]		
F1 Help ↑↓ Select Item -/+ Change Values F9 Setup Defaults		
Esc Exit ←→ Select Menu Enter Select ► Sub-Menu F10 Save and Exit		

Figure 4.5. I/O Device Configuration Window (Factory Settings)

- Serial port A : This setting is for SERIAL1 on the equipment connector plane.
- Serial port B : This setting is for SERIAL2 on the equipment connector plane.
- Serial port C : This setting is for serial communication of the touch panel.
- Serial port D : This setting is for RS-422/485 in the RAS connector on the equipment connector plane or for SERIAL4 on the equipment connector plane.
- Parallel port : This setting is for PRINTER on the equipment connector plane.

Fields available with Parallel port set to [Enabled]

- Base I/O address : Set to base I/O address.
- Interrupt : Set to IRQ.
- Mode : Set to parallel port's operating mode.
- DMA channel : This is the DMA channel setting used when ECP is selected during parallel-port mode setting.
- Floppy disk controller : Enable or disable the on-board floppy disk controller. Normally, set to default.
- PCMCIA interrupt : Used to set the interrupt used by the PCMCIA controller. The default is IRQ10. Change this in cases such as when an ISA board uses IRQ10.

ISA Bridge Window

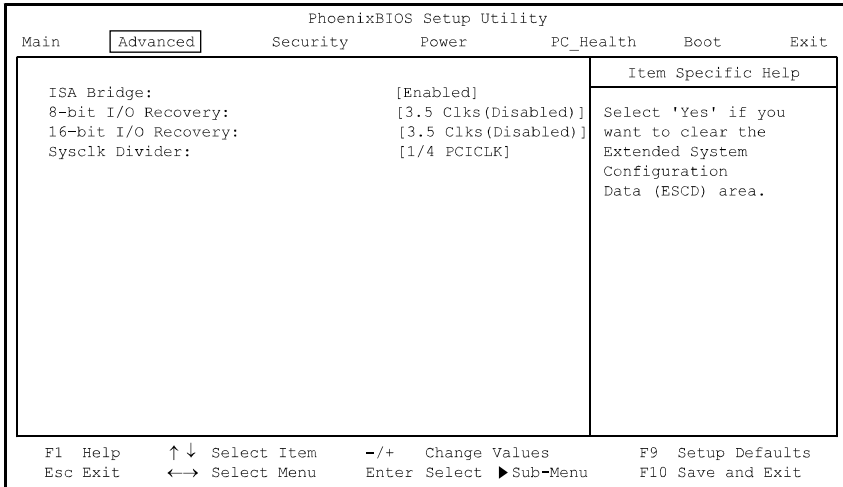

Figure 4.6. ISA Bridge Window (Factory Settings)

- ISA Bridge** : Used to enable or disable the ISA bus expansion slots. As the default setting is "Enable", set to "Disable" if not using the ISA bus.
- 8-bit I/O Recovery** : Set the speed for 8-bit I/O on ISA bus boards.
The default is 3.5Clks. You should normally leave the default setting.
- 16-bit I/O Recovery** : Set the speed for 16-bit I/O on ISA bus boards.
The default is 3.5Clks. You should normally leave the default setting.
- Sysclk Divider** : Select the ISA bus clock.
The default is 1/4 PCICLK (33MHz/4 = 8.25MHz).
You should normally leave the default setting.

Security Window

PhoenixBIOS Setup Utility						
Main	Advanced	Security	Power	PC_Health	Boot	Exit
Set Supervisor Password : [Enter] Set User Password : [Enter] Supervisor Password Is : Clear User Password Is : Clear Password on boot : [Disabled] Clear All Passwords : [Enter]					Item Specific Help Supervisor Password controls access to the setup utility.	
F1 Help		↑↓ Select Item	-/+ Change Values	F9 Setup Defaults		
Esc Exit		←→ Select Menu	Enter Select	▶ Sub-Menu	F10 Save and Exit	

Figure 4.7. Security Window (Factory Settings)

- Set Supervisor Password :** Specify whether or not to require a password during setup. If a password is set, "Supervisor Password is" is enabled. Supervisor mode allows all settings to be set.
- Set User Password :** Specify whether or not to require a password during setup. If a password is set, "User Password is" is enabled. User mode allows only the date and time to be set.
- Password on boot :** Specify whether or not to require a password when booting.
- Clear All Password :** Both passwords can be erased by Supervisor.

CAUTION

Once a password is registered, even the password function itself cannot be cancelled without the password. Passwords should be handled with great care.

Power Window

PhoenixBIOS Setup Utility	
Main	Advanced
Security	Power
PC_Health	Boot
Exit	
Enable ACPI : [No] ACPI Suspend Mode : [Disabled] APM Capabilities : [Disabled] Power Saving : [Disabled] Standby Timeout : [Off] Suspend Timeout : [Off] ▶ Wake-up Event	Item Specific Help Select 'Yes' if you want to clear the Extended System Configuration Data (ESCD) area.
F1 Help ↑↓ Select Item -/+ Change Values F9 Setup Defaults Esc Exit ←→ Select Menu Enter Select ▶ Sub-Menu F10 Save and Exit	

Figure 4.8. Power Window (Factory Settings)

- Enabled ACPI : Set to "No".
- ACPI Suspend Mode : Set to "Disabled".
- APM Capabilities : Set to "Disabled".
- Power Savings : Specify whether or no to use power-saving mode. Choose from "Disabled", "Customize," "Maximum Power Savings," and " Maximum Performance."
- Standby Timeout : Specify the length of time from the idle state through entry into standby mode. Standby mode turns off the power to peripherals including the screen.
- Suspend Timeout : Specify the time of transition from standby mode to suspend mode.
- Wake-up Event : Start Wake-up Event as shown above. You can specify the wake-up event that resumes the system from the BIOS-based standby state. In principle, leave this field at the default for normal use.

PC-Health Window

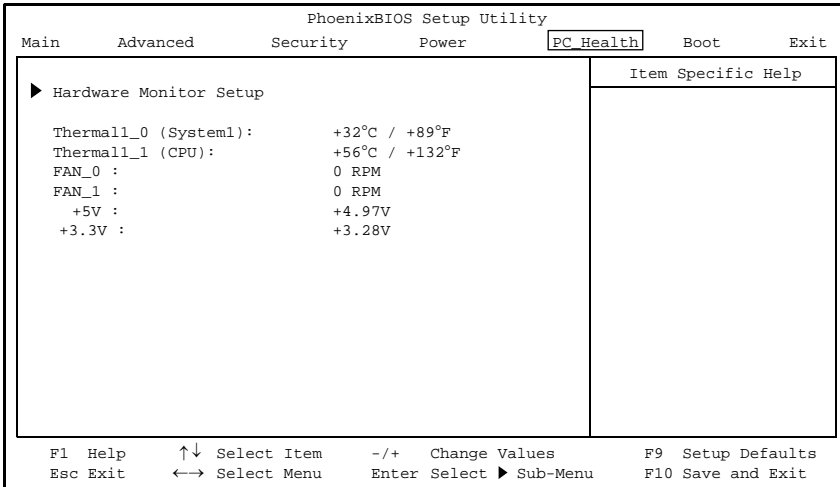

Figure 4.9. PC-Health Window (Factory Settings)

Hardware Monitor Setup : Start Hardware Monitor Setup as shown above. Although you can make fan settings, leave this field at the default because the PANECON-PC uses no CPU fan.

Thermal_0 (System1) : Displays the temperature detected by the Thermal_0 temperature sensor.

Thermal_1 (CPU) : Displays the temperature detected by the CPU temperature sensor.

FAN_0 : Reads "0 RPM" as this PANECON-PC uses no Fan 0.

FAN_1 : Reads "0 RPM" as this PANECON-PC uses no Fan 0.

+5V : Displays a voltage of +5 V.

+3.3V : Displays a voltage of +3.3 V.

Boot Window

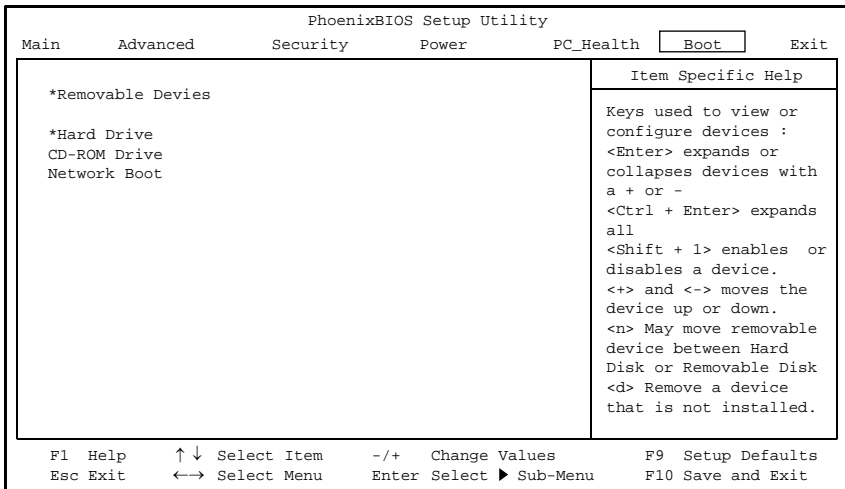

Figure 4.10. Boot Window

Specify the order in which the system to be booted is checked. Using the <+> or <-> key, rearrange the selected items.

- Removable Devices : Removable devices such as the floppy disk.
- Hard Drive : Devices that is not removable, such as the hard disk drive and silicon disk drive.
- CD-ROM Drive : Optional CD-ROM drive (IDE connection)
- Network Boot : This item is not available.

The items are displayed on the menu in priority order.

Exit Window

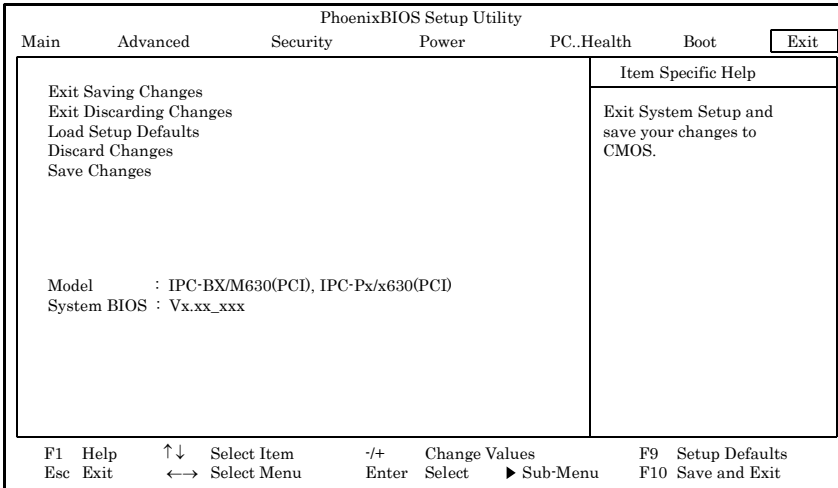

Figure 4.11. Exit Window

- Exit Saving Changes : Saves values that have been modified on the setup screen in CMOS (EEPROM) and restarts the system.
- Exit Discarding Changes : Restarts the system using the previous values without saving modified values in CMOS (EEPROM).
- Load Setup Defaults : Sets default values that are in the possession of BIOS.
- Discard Changes : Loads values that are currently in the possession of CMOS(EEPROM).
- Save Changes : Saves values that have been modified on the setup screen in CMOS (EEPROM).

“Model” indicates the model type, while “System BIOS” refers to the BIOS version. These two items are used for confirmation purposes; therefore they shall not be set.

5. Each Component Function

Component Identification

IPC-PT/L620S(PCW)C, IPC-PT/H620X(PCW)C

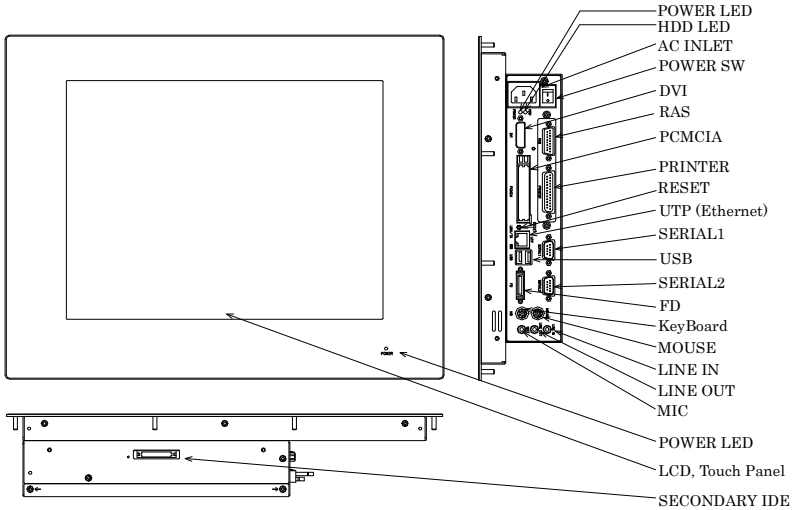

Figure 5.1. Component Identification < 1 / 2 >

IPC-PT/L620S(PCW)CP, IPC-PT/H620X(PCW)CP

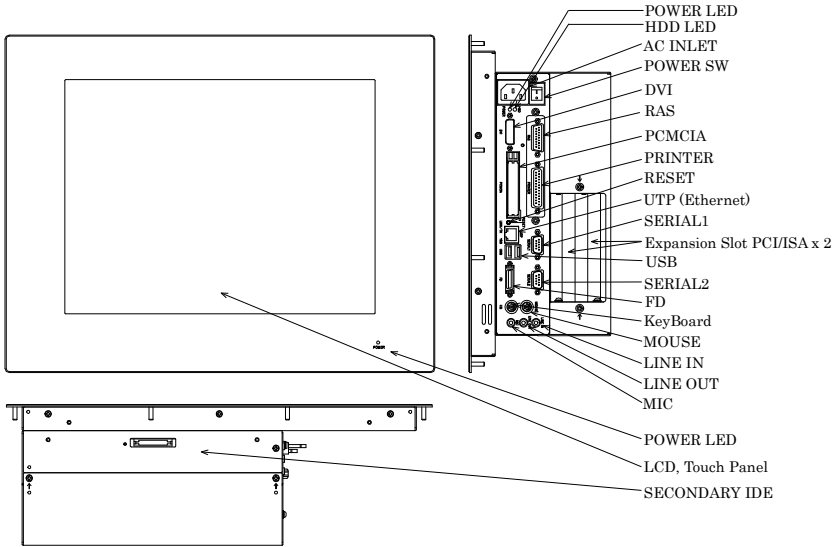

Figure 5.1. Component Identification < 2 / 2 >

Table 5.1. Component Functions

Component	Function
LINE IN	Line in (φ3.5 PHONE JACK)
LINE OUT	Line out (φ3.5 PHONE JACK)
MIC	Microphone input (φ3.5 PHONE JACK)
KB	Keyboard connector (MINI-DIN, 6pin)
MOUSE	PS/2 mouse connector (MINI-DIN, 6pin)
SERIAL1	Serial port 1 connector (9pin, male D-SUB)
SERIAL2	Serial port 2 connector (9pin, male D-SUB)
FD	Floppy disk drive connector (26pin, half-pitch connector)
USB	USB port connector
UTP	Ethernet connector (RJ-45)
PCMCIA	PCMCIA card slot
DVI*1	DVI connector (29pin, DVI-I)
PRINTER	Parallel port connector (25pin, female D-SUB)
RAS	RAS function and RS-485 connector (15pin, female D-SUB)
RESET	Hard reset push button
Expansion Slot	PCI expansion board slot x 2 <CP model>
POWER	Power ON indicator
HDD	Internal hard disk access lamp
POWER SW	Power switch
AC INLET	AC power supply input connector
SECONDARY IDE	Secondary IDE connector (dedicated 40pin half pitch connector)

*1: Using the DVI-analog RGB adapter (accessory bundled) allows an analog RGB monitor to be connected to the IPC-PT/x620x (PCW).

Line in Interface

A line input connector is provided, named LINE IN (3.5-mm stereo mini jack). You can connect the audio output, for example, of a CD player to this connector to record data from the CD or to play it through LINE OUT.

Line out Interface

A line output connector is provided, named LINE OUT (3.5-mm stereo mini jack). You can plug a headphone or amplifier-integrated speakers into this connector.

MIC input Interface

A MIC input connector is provided, named MIC (3.5-mm stereo mini jack). You can plug a microphone to this connector for sound input.

Audio driver

The audio driver is required to use the line input, line output, and microphone input interfaces.

Visit the CONTEC web site to download the audio driver

(IPC-SLIB-01) for the OS running on your PANECON-PC.

For the download, see Chapter 7 "List of Options".

Keyboard Interface

The PANECON-PC is equipped with a keyboard connector named KB (MINI-DIN 6P).

Table 5.2. Keyboard Connector

Connector type		Equivalent to the MD-DS12300-14S-14 (JST)	
Pin No.	Signal	Pin No.	Signal
1	+KBD DATA	5	+KBD CLK
2	N.C.	6	N.C.
3	GND	SHIELD	GND
4	+5.0V DC	---	

Mouse Interface

The PANECON-PC is equipped with a mouse connector named MOUSE (MINI-DIN 6P).

Table 5.3. Mouse Connector

Connector type		Equivalent to the MD-DS12300-14S-14 (JST)	
Pin No.	Signal	Pin No.	Signal
1	+MOUSE DATA	5	+MOUSE CLK
2	N.C.	6	N.C.
3	GND	SHIELD	GND
4	+5.0V DC	---	

Serial Port Interface

Serial port A and B(RS-232C Ports)

The PANECON-PC is equipped with two RS-232C-compliant serial port connectors (SERIAL1: Serial port A and SERIAL2: Serial port B). You can use BIOS Setup (described in Chapter 3) to configure an I/O address, interrupt and unused state for each of the ports independently. (The same I/O address and IRQ cannot be shared with any other device.)

Table 5.4. SERIAL A and B I/O Addresses and Interrupts

COM	I/O address	Interrupt
1	3F8h - 3FFh	IRQ 3 IRQ 4
2	2F8h - 2FFh	
3	3E8h - 3EFh	
4	2E8h - 2EFh	

The BIOS defaults to the following factory settings:

Serial port A: COM1 (3F8h-3FFh) , IRQ4

Serial port B: COM2 (2F8h-2FFh) , IRQ3

Table 5.5. Serial Port Connector

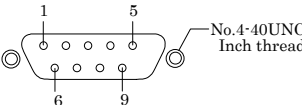
Connector used on the unit		9-socket D-SUB (MALE)	
			
Pin No.	Signal	Meaning	Direction
1	CD	Carrier detect	Input
2	RD	Received data	Input
3	TD	Transmitted data	Output
4	DTR	Data terminal ready	Output
5	GND	Signal ground
6	DSR	Data set ready	Input
7	RTS	Request to send	Output
8	CTS	Clear to send	Input
9	RI	Ring indicator	Input

Serial port C(touch panel)

One channel of serial port is provided for use as a touch panel connector.

You can use BIOS Setup (described in Chapter 3) to configure an I/O address, interrupt and unused state for this port. (The same I/O address and IRQ cannot be shared with any other device.)

Table 5.6. Serial port C I/O Addresses and Interrupts

COM	I/O address	Interrupt
1	3F8h - 3FFh	IRQ 3
		IRQ 4
2	2F8h - 2FFh	IRQ 5
		IRQ 7
3	3E8h - 3EFh	IRQ 9
		IRQ 10
4	2E8h - 2EFh	IRQ 11
		IRQ 15

The BIOS defaults to the following factory settings:

Serial port C: COM3(3E8h-3EFh), IRQ5

Serial port D (RS-422/485 port)

One channel of serial port is provided for use as a RS-422/485 port.

You can use BIOS Setup (described in Chapter 3) to configure an I/O address, interrupt and unused state for this port. (The same I/O address and IRQ cannot be shared with any other device.)

Table 5.7. Serial port D I/O Addresses and Interrupts

COM	I/O address	Interrupt
1	3F8h - 3FFh	IRQ 3
		IRQ 4
2	2F8h - 2FFh	IRQ 5
		IRQ 7
3	3E8h - 3EFh	IRQ 9
		IRQ 10
4	2E8h - 2EFh	IRQ 11
		IRQ 15

The BIOS defaults to the following factory settings:

Serial port D: COM4(2E8h-2EFh), IRQ11

Output connector with the RS-422/RS-485 mounted (factory default)**Table 5.8. Output connector with the RS-422/RS-485 mounted (RAS Connector)**

Pin No.	Signal	Meaning
2	TX +	Transmitted data +
10	TX -	Transmitted data
3	RX +	Received data +
11	RX -	Received data -

Reference

For more information on the RAS connector see Table 5.20, "RAS connector."

RS-422/RS-485 Specifications

- Transmission method : RS-422/RS-485-compliant, asynchronous, serial transmission, half duplex/full duplex
- Baud rate : 50 - 19,200bps (programmable)
- Signal extension distance : 1.2km Max.

Terminal Resistor when RS-485 is in Use

Set with JP4 inside the top cover. The factory setting is "terminal resistor not available."

**Figure 5.2. Terminal Resistor Settings**

Control of Transmitted Data in Half-Duplex Mode

In half-duplex mode, the transmission buffer needs to be controlled in order to prevent collision of transmitted data. The PANECON-PC uses RTS and controls the buffer with modem control register's bit 1. Transmission and reception gate control by the register setting of port address 4006h and 4007h is allowed only for the RS-422/485 (Serial port D). For more information see section, "General-purpose I/O and Remote Reset" in Chapter 5.

Modem control register

(Set I/O address +4H) bit 1: 0 ... RTS is High. (Disable transmission)
 1 ... RTS is Low. (Enable transmission)

I/O Addresses and Instructions

The I/O addresses and instructions of COM1 are shown next.

Table 5.9. I/O Addresses

I/O address	DLAB	Read/Write	Register	
03F8H	0	W	Transmitter holding register	THR
			Receive buffer register	RBR
	1	W	Divisor latch register	DLL
03F9H	1	W	Divisor latch register	DLM
	0	W	Interrupt enable register	IER
03FAH	X	R	Interrupt ID register	IIR
03FBH	X	W	Line control register	LCR
03FCH	X	W	Modem control register	MCR
03FDH	X	R	Line status register	LSR
03FEH	X	R	Modem status register	MSR
03FFH	X	R/W	Scratch register	SCR

DLAB (Divisor Latch Access Bit) : The value in bit 7 of the line control register

Table 5.10. Function of Each Register < 1 / 4 >

I/O address	Description
03F8H	<p>THR: Transmitter Holding Register [DLAB=0]</p> <p>D7 D6 D5 D4 D3 D2 D1 D0</p>  <p>Register dedicated to write transmitted data to</p>
03F8H	<p>RBR: Receiver Buffer Register [DLAB=0]</p> <p>D7 D6 D5 D4 D3 D2 D1 D0</p>  <p>Register dedicated to read received data from</p>
03F8H	<p>DLL: Divisor Latch (LSB) [DLAB=1]</p> <p>D7 D6 D5 D4 D3 D2 D1 D0</p>  <p>Baud rate setting register (LSB)</p>
03F9H	<p>DLH: Divisor Latch (MSB) [DLAB=1]</p> <p>D7 D6 D5 D4 D3 D2 D1 D0</p>  <p>Baud rate setting register (MSB)</p>
03F9H	<p>IER: Interrupt Enable Register [DLAB=0]</p> <p>D7 D6 D5 D4 D3 D2 D1 D0</p>  <p>Received data Interrupt enable Received data register empty Interrupt enable Receiver line status Interrupt enable Modem status interrupt enable [Always used at 0.]</p> <p>1: Enable interrupt 0: Disable interrupt</p>

Table 5.10. Function of Each Register < 2 / 4 >

I/O address	Description																																						
03FAH	<p>IIR : Interrupt Identification Register</p> <p>D7 D6 D5 D4 D3 D2 D1 D0</p> <table border="1" style="margin-left: 40px;"> <tr> <td style="width: 20px; height: 20px;">0</td> <td style="width: 20px; height: 20px;">0</td> <td style="width: 20px; height: 20px;">0</td> <td style="width: 20px; height: 20px;">0</td> <td style="width: 20px; height: 20px;">0</td> <td style="width: 20px; height: 20px;">←</td> <td style="width: 20px; height: 20px;">→</td> <td style="width: 20px; height: 20px;"></td> </tr> </table> <p style="margin-left: 100px;">Interrupt details</p> <p style="margin-left: 150px;">1: Do not generate interrupts 0: Generate interrupts</p> <table border="1" style="margin-top: 10px;"> <thead> <tr> <th>bit2</th> <th>bit1</th> <th>bit0</th> <th>Priority</th> <th>Description</th> </tr> </thead> <tbody> <tr> <td>0</td> <td>0</td> <td>1</td> <td>—</td> <td>Interrupts are not generated.</td> </tr> <tr> <td>1</td> <td>1</td> <td>0</td> <td>1 (high)</td> <td>Generated by overrun, parity, framing error or break interrupt. Cleared when the line status register is read.</td> </tr> <tr> <td>1</td> <td>0</td> <td>0</td> <td>2</td> <td>Generated when the receive buffer register is ready. Cleared when the receiving buffer is read.</td> </tr> <tr> <td>0</td> <td>1</td> <td>0</td> <td>3</td> <td>Generated when the transmitter holding register is empty. Cleared when the IIR is read or when transmitted data is written to THR.</td> </tr> <tr> <td>0</td> <td>0</td> <td>0</td> <td>4 (low)</td> <td>Modem status interrupt is generated. (CTS, DSR, RI, CD) Cleared when the modem status register is read.</td> </tr> </tbody> </table>	0	0	0	0	0	←	→		bit2	bit1	bit0	Priority	Description	0	0	1	—	Interrupts are not generated.	1	1	0	1 (high)	Generated by overrun, parity, framing error or break interrupt. Cleared when the line status register is read.	1	0	0	2	Generated when the receive buffer register is ready. Cleared when the receiving buffer is read.	0	1	0	3	Generated when the transmitter holding register is empty. Cleared when the IIR is read or when transmitted data is written to THR.	0	0	0	4 (low)	Modem status interrupt is generated. (CTS, DSR, RI, CD) Cleared when the modem status register is read.
0	0	0	0	0	←	→																																	
bit2	bit1	bit0	Priority	Description																																			
0	0	1	—	Interrupts are not generated.																																			
1	1	0	1 (high)	Generated by overrun, parity, framing error or break interrupt. Cleared when the line status register is read.																																			
1	0	0	2	Generated when the receive buffer register is ready. Cleared when the receiving buffer is read.																																			
0	1	0	3	Generated when the transmitter holding register is empty. Cleared when the IIR is read or when transmitted data is written to THR.																																			
0	0	0	4 (low)	Modem status interrupt is generated. (CTS, DSR, RI, CD) Cleared when the modem status register is read.																																			
03FBH	<p>LCR : Line Contror Register</p> <p>D7 D6 D5 D4 D3 D2 D1 D0</p> <table border="1" style="margin-left: 40px; margin-top: 10px;"> <thead> <tr> <th>D1</th> <th>D0</th> <th>Bit table</th> </tr> </thead> <tbody> <tr> <td>0</td> <td>0</td> <td>5</td> </tr> <tr> <td>0</td> <td>1</td> <td>6</td> </tr> <tr> <td>1</td> <td>0</td> <td>7</td> </tr> <tr> <td>1</td> <td>1</td> <td>8</td> </tr> </tbody> </table> <p style="margin-left: 100px;">0 : 1 STOP bit 1 : 1.5 STOP bits at 5-bit length 2 STOP bits at 6-, 7-, or 8-bit length</p> <p style="margin-left: 100px;">0 : Disable parity 1 : Enable parity</p> <p style="margin-left: 100px;">0 : Odd parity 1 : Even parity</p> <p style="margin-left: 100px;">0 : Disable stick parity 1 : Enable stick parity</p> <p style="margin-left: 100px;">0 : Break signal off 1 : Send break signal</p> <p style="margin-left: 20px;">DLAB (Divisor Latch Access Bit) In order to access the divisor latch register, you need to set the bit to 1. To access another register, set the bit to 0.</p>	D1	D0	Bit table	0	0	5	0	1	6	1	0	7	1	1	8																							
D1	D0	Bit table																																					
0	0	5																																					
0	1	6																																					
1	0	7																																					
1	1	8																																					

Table 5.10. Function of Each Register < 3 / 4 >

I/O address	Description																
03FCH	<p>MCR: Modem Control Register</p> <table border="1" data-bbox="277 268 642 312"> <thead> <tr> <th>D7</th> <th>D6</th> <th>D5</th> <th>D4</th> <th>D3</th> <th>D2</th> <th>D1</th> <th>D0</th> </tr> </thead> <tbody> <tr> <td>0</td> <td>0</td> <td>0</td> <td>Loop</td> <td>IRQ</td> <td>X</td> <td>RTS</td> <td>DTR</td> </tr> </tbody> </table> <p> DTR 0 : Inactive [HIGH] 1 : Active [LOW] RTS 0 : Inactive [HIGH] 1 : Active [LOW] Interrupt control bit 0 : Disable 1 : Enable Diagnostic local loop-back test 0 : Disable 1 : Enable </p>	D7	D6	D5	D4	D3	D2	D1	D0	0	0	0	Loop	IRQ	X	RTS	DTR
D7	D6	D5	D4	D3	D2	D1	D0										
0	0	0	Loop	IRQ	X	RTS	DTR										
03FDH	<p>LSR: Line Status Register</p> <table border="1" data-bbox="277 683 642 727"> <thead> <tr> <th>D7</th> <th>D6</th> <th>D5</th> <th>D4</th> <th>D3</th> <th>D2</th> <th>D1</th> <th>D0</th> </tr> </thead> <tbody> <tr> <td>0</td> <td>TEMT</td> <td>THRE</td> <td>BI</td> <td>FE</td> <td>PE</td> <td>OE</td> <td>DR</td> </tr> </tbody> </table> <p> Data ready (1 for existence of received data) Overrun error (1 for occurrence of an error) Parity error (1 for occurrence of an error) Framing error (1 for occurrence of an error) Break interrupt (1 for detection of break state) Transmitter holding register empty (1 for transmission buffer being empty) Transmitter empty (Set to 1 when both transmitter holding register and transmitter shift register are empty) </p>	D7	D6	D5	D4	D3	D2	D1	D0	0	TEMT	THRE	BI	FE	PE	OE	DR
D7	D6	D5	D4	D3	D2	D1	D0										
0	TEMT	THRE	BI	FE	PE	OE	DR										

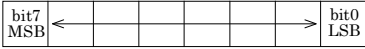
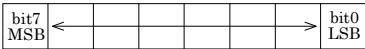
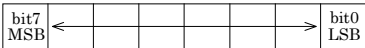
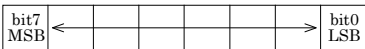
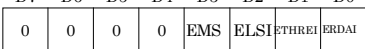
Table 5.10. Function of Each Register < 4 / 4 >

I/O address	Description																
03FEH	<p>MSR : Modem Status Register</p> <table border="1" style="margin-left: auto; margin-right: auto;"> <tr> <td>D7</td><td>D6</td><td>D5</td><td>D4</td><td>D3</td><td>D2</td><td>D1</td><td>D0</td> </tr> <tr> <td>DCD</td><td>RI</td><td>DSR</td><td>CTS</td><td>DDCD</td><td>TERI</td><td>DDSR</td><td>DCTS</td> </tr> </table> <p style="margin-left: 40px;"> DCD → DCD RI → RI DSR → DSR CTS → CTS DDCD → Delta data carrier detect TERI → Trailing edge RI DDSR → Delta DSR DCTS → Delta CTS </p> <p style="text-align: right; margin-right: 20px;"> Since these statuses are not used with RS-485, data is not valid. </p>	D7	D6	D5	D4	D3	D2	D1	D0	DCD	RI	DSR	CTS	DDCD	TERI	DDSR	DCTS
D7	D6	D5	D4	D3	D2	D1	D0										
DCD	RI	DSR	CTS	DDCD	TERI	DDSR	DCTS										
03FFH	<p>SCR : Scratchpad Register</p> <p>This is an 8-bit, readable/writable register which is available to the user to allow data to be saved temporarily.</p>																

Baud Rate Settings

A baud rate is set by software by dividing the clock input (1.8432MHz). The baud rate in terms of hardware can be set to a maximum of 115,200 bps. The baud rates available in practice depend on the operating environment (cable, software, etc.). The table below lists typical baud rates and their respective values to be written to the divisor latch register (LSB, MSB).

Table 5.11. Baud Rate Settings

Baud rate to be set	Value to be set in the divisor register	Setting error (%)
50	2304	---
75	1536	---
110	1047	0.026
134.5	857	0.058
150	768	---
300	384	---
600	192	---
1200	96	---
1800	64	---
2000	58	0.69
2400	48	---
3600	32	---
4800	24	---
7200	16	---
9600	12	---
19200	6	---

Example: To set 9,600 bps, write "00" to the (MSB) divisor latch register and "12 (decimal)" to the (LSB) divisor latch register.

Floppy Disk Interface

The PANECON-PC is equipped with a FD controller to allow one FD drive to be connected to the FD connector named FD on the front end. Use the FD drive that is available as a dedicated option.

Table 5.12. FD Connector

Connector in use		26-pin socket, half-pitch connector, Equivalent to the DX10G1M-26SE			
Pin No.	Signal	Direction	Pin No.	Signal	Direction
1	HDSEL	Output	2	WRTPRT	Input
3	RDATA	Input	4	TRK0	Input
5	GND	-----	6	GND	-----
7	GND	-----	8	WGATE	Output
9	GND	-----	10	GND	-----
11	WDATA	Output	12	GND	-----
13	DENSEL	Output	14	STEP	Output
15	DENSEL	Output	16	DIR	Output
17	N.C.	-----	18	MTR_ON	Output
19	DRV_SEL	Output	20	N.C.	-----
21	+5V	-----	22	DSKCHG	Input
23	+5V	-----	24	N.C.	-----
25	INDEX	Input	26	+5V	-----

Compatible Connector on the Cable Side

Plug connector : AMP, P/N 1756774-4 (AWG#28 for pressure welding)

Shield case kit : AMP, P/N 1756774-4

or

Plug connector : 3M, P/N 10126-6000EL (AWG#28 for pressure welding)

Shell : 3M, P/N 10326-3210-000

or

Plug connector : 3M, P/N 10126-3000VE (AWG#24 - #30 provided with solder)

Shell system : 3M, P/N 10326-52F0-008 (Non-shield shell kit)

Cable Length

Use within a maximum cable length of 60cm.

USB Ports

The PANECON-PC is equipped with two USB interface channels.

Table 5.13. USB Connector

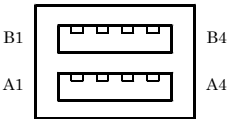

Pin No.	Signal	Pin No.	Signal
A1	USB0 Vcc	B1	USB1 Vcc
A2	USB0 ·Data	B2	USB1 ·Data
A3	USB0 +Data	B3	USB1 +Data
A4	USB0 GND	B4	USB1 GND

Ethernet

A Fast Ethernet interface is provided.

- Network type : 100BASE-TX/10BASE-T
 - Transmission speed* : 100M/10M bps
 - Max. network path length : 100m/ segment
 - Controller : ICH2 integrated (Intel)
- * Operation at 100Mbps requires a category 5 cable.

Table 5.14. Ethernet Connector

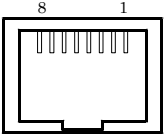
Connector type	RJ-45	
		
Pin No.	Signal	Meaming
1	TD+	Transmitted data (+)
2	TD-	Transmitted data (-)
3	RD+	Received data (+)
4	N.C.	Not connected
5	N.C.	Not connected
6	RD-	Received data (-)
7	N.C.	Not connected
8	N.C.	Not connected

LEDs for display of network statuses:

- LINK : Normal connection indicator
- FDX : Full-duplex mode indicator
- 100M : 100M-operation indicator

LAN drivers

Visit the CONTEC web site to download the LAN driver (IPC-SLIB-01) for the OS running on your PANECON-PC.

For the download, see Chapter 7 "List of Options".

PC Card Slots

PCMCIA compliant, CardBus compatible card slots are provided. [TYPE II x 2 (TYPE III x 1) size]

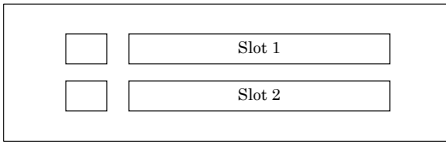

Figure 5.3. Slot Numbers and Locations

CAUTION

A type III card should be inserted into slot 2.

Attaching the Metal Brace to Keep the Card in Place

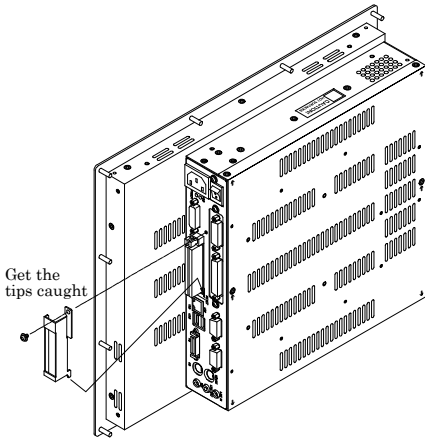

Figure 5.4. Attaching the Metal Brace to Keep the Card in Place

Power Supply to the Card

The voltage that can be used and the current capacity of each slot are as shown below:

Table 5.15. Power Supply to the Card

Voltage	Current capacity (Max.)
+5V	1A/Slot
+3.3V	1A/Slot
+12V	Not supplied.

DVI Interface

A DVI interface is provided. Using the bundled DVI-analog RGB adapter allows a display monitor with DB-15 connector to be connected to the IPC-PT/x620x(PCW). The connector is named DVI (DVI-I 29-pin connector).

Table 5.16. DVI Connector

DVI Connector		DVI-I 29 pin			
Pin No.	Signal	Pin No.	Signal	Pin No.	Signal
1	N.C.	13	N.C.	C1	RED
2	N.C.	14	+5V	C2	GREEN
3	N.C.	15	GND	C3	BLUE
4	N.C.	16	HPD	C4	HSYNC
5	N.C.	17	N.C.	C5	GND
6	DDC CLK	18	N.C.		
7	DDC DATA	19	N.C.		
8	VSYNC	20	Reserved		
9	N.C.	21	Reserved		
10	N.C.	22	N.C.		
11	N.C.	23	N.C.		
12	N.C.	24	N.C.		

Table 5.17. DVI-Analog RGB conversion adapter

Connector		DVI-I 29pin	
Analog RGB signals			
Pin No.	Signal	Pin No.	Signal
1	RED	9	HPD
2	GREEN	10	GND
3	BLUE	11	N.C.
4	N.C.	12	DDC DATA
5	GND	13	HSYNC
6	GND	14	VSYNC
7	GND	15	DDC CLK
8	GND		

Display Driver

Visit the CONTEC web site to download the Display driver (IPC-SLIB-01) for the OS running on your PANECON-PC.

For the download, see Chapter 7 “List of Options”.

Printer Port Interface

A printer port is provided. You can use BIOS Setup to configure an operation mode, I/O address, interrupt, DMA channel and unused state for this port. The connector is named PRINTER.

Table 5.18. Printer Ports and I/O Addresses

I/O address	Interrupt
3BCh to 3BFh	IRQ 5
378h to 37Fh	IRQ 7
278h to 27Fh	

The BIOS defaults to the following factory settings:

Parallel port: ECP, 378h - 37Fh, IRQ7, DMA3,

Table 5.19. Printer Port Connector

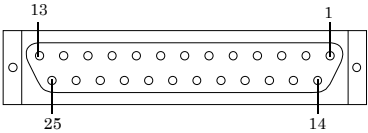
Connector used on the unit				25pin D-SUB (FEMALE)			
							
Pin No.	Signal	Meaning	Direction	Pin No.	Signal	Meaning	Direction
1	-STRB	Enable data	Output	14	-AFEEED	Automatic feed	Output
2	D 0	Data bit 0	Output	15	-ERROR	Not available	Input
3	D 1	Data bit 1	Output	16	-INIT	Initialize	Output
4	D 2	Data bit 2	Output	17	-SELECT*IN	Input allowed	Output
5	D 3	Data bit 3	Output	18	GND	Ground	-----
6	D 4	Data bit 4	Output	19	GND	Ground	-----
7	D 5	Data bit 5	Output	20	GND	Ground	-----
8	D 6	Data bit 6	Output	21	GND	Ground	-----
9	D 7	Data bit 7	Output	22	GND	Ground	-----
10	-ACK	Ready to accept data	Input	23	GND	Ground	-----
11	BUSY	Busy	Input	24	GND	Ground	-----
12	PE	Out of paper	Input	25	GND	Ground	-----
13	SELECT	Select state	Input	-----			

Fastening screw: No. 4-40 UNC inch thread

RAS Functions

A RAS port is provided. This port offers watchdog timer, remote reset, and general-purpose I/O RAS functions.

Table 5.20. RAS Connector

Connector type		15pin D-SUB(FEMALE) (DALC-J15SAF-20L9) JAE
Pin No.	Signal	Function
1	SPK	External speaker signal
9	GND	External speaker ground
2	TX +	RS-485 transmitting line
10	TX -	
3	RX +	RS-485 receiving line
11	RX -	
4	NCOM	Minus common dedicated to PO2
12	PO2/WDT	General-purpose output or watchdog timer alarm output
5	PO0	General-purpose output
13	PO1	
6	NCOM	General-purpose output minus common
7	PI1	General-purpose input
14	PI2/IRQ	General-purpose input or interrupt input
8	PCOM	General-purpose input plus common
15	PI0	General-purpose input

*Fastening screw: No. 4-40UNC inch thread

port address: 4000h - 4007h

⚠ CAUTION

Pin 4 NCOM (minus common dedicated to PO2) and pin 6 NCOM (minus common shared by PO0 and PO1) are electrically separated from each other.

Watchdog Timer

The watchdog timer is started by output of A5 to I/O port address 4002h. A second output of A5 to the same port within the specified expiration time once again triggers the watchdog timer. If a time-out occurs, a reset or an interrupt is generated according to the 4004h port setting or an alarm is output according to the 4004h port setting.

The time-out period can be set between 1 and 255 seconds depending on the timer value setting for the WDT counter port (4003h).

The watchdog timer stops by reading port 4002h. The alarm-out output is cancelled at the same time.

The alarm out is output from the RAS connector's PO2/WDT (pin 12) and cancelled when reset.

The alarm-out output can be set to BIOS startup by BIOS setup (see Chapter 4), watchdog timer startup, or watchdog timer time-up.

Specifications

- Time to be set : 1sec - 255sec
- Interrupt or reset : Resets or generates an interrupt at time-up (Port setting).
- External alarm output : Optocoupler isolated open-collector output (the output status is set by software). For more information, see the general-purpose I/O specifications.
- I/O addresses : 4000h - 4007h (RAS port)

How to Use the Watchdog Timer

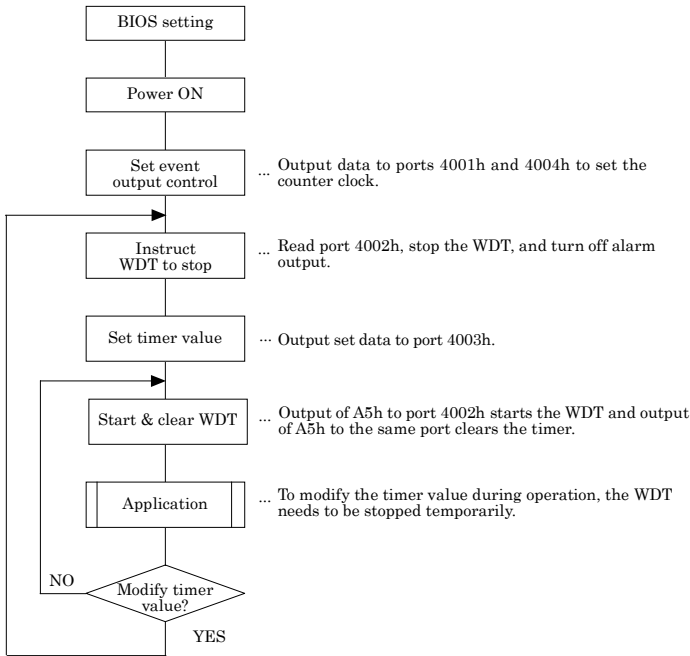

*WDT: Watch Dog Timer

Figure 5.5. How to Use the Watchdog Timer

- Example usage:** To assign IRQ5 to the event whose time-up value is 15sec:
- Out 4004h 01h : Set the event at the time of WDT expiration to IRQ5.
 - In 4002h : Stop the WDT timer and cancel the alarm.
 - Out 4003h 0Fh : Set the WDT expiration time to 15sec.
 - Out 4002h A5h : Start and clear the WDT.
 - In 4002h : Stop the WDT and cancel the alarm.

*** 4001h (bit4-6): Alarm out output control**

D7	D6	D5	D4	D3	D2	D1	D0	
---	WD_S1	WD_S0	PO2_M	RESET	PIM2	PIM1	PIM0	R/W (default: XXXX0000b)

Figure 5.6. Alarm Out Output Control Port (4001h)

PO2_M : PO PO2/WDT pin output setting

0 : Set the RAS connector's PO2/WDT(12) signal to PO2 (general-purpose output).

1 : Set the RAS connector's PO2/WDT(12) signal to alarm out.

Table 5.21. WD_S1, WD_S0: Alarm-out Output Status Settings

WD_S1	WD_S0	External alarm output status			
		When power is turned off *1	When BIOS starts *1	When WDT starts	When time expires on WDT
0	0	OFF	OFF	OFF	ON
1	0	OFF	OFF	ON	OFF
1	1	OFF	ON	ON	OFF
0	1	OFF	ON	OFF	ON

*** 4002h: WDT control**

D7	D6	D5	D4	D3	D2	D1	D0	
—	—	—	—	—	—	—	—	R/W

Figure 5.7. WDT Control Port (4002h)

R : Cancels WDT stop/alarm. Read data is undefined.

W : Start and clear the WDT. Write A5h to start and clear the WDT.

*** 4003h: WDT counter**

D7	D6	D5	D4	D3	D2	D1	D0	
T7	T6	T5	T4	T3	T2	T1	T0	W

Figure 5.8. WDT Counter Port (4003h)

W : Writes watchdog timer count data. Write watchdog timer counter expiration time data.

1sec → 01h

8sec → 08h

15sec → 0Fh

30sec → 1Eh

*** 4004h : Event output control**

D7	D6	D5	D4	D3	D2	D1	D0	
---	---	---	---	RESET	WM2	WM1	WM0	R/W (Default: XXXX0000b)

Figure 5.9. Event Output Control Port (4004h)

Table 5.22. WM2 - WM0: Interrupt Output Modes

WM2	WM1	WM0	Interrupt output at occurrence of WDT errors
0	0	1	Output to IRQ5 when time expires on the WDT.
0	1	0	Output to IRQ7 when time expires on the WDT.
0	1	1	Output to IRQ9 when time expires on the WDT.
1	0	0	Output to IRQ10 when time expires on the WDT.
1	0	1	Output to IRQ11 when time expires on the WDT.
Others			Inhibits output when time expires on the WDT.

Table 5.23. RESET: Reset Output Modes

RESET	RESET output at occurrence of WDT errors
0	Inhibits RESET output when time expires on the WDT.
1	Allows RESET output when time expires on the WDT.

(Note) When time expires on WDT, the alarm-out is output irrelevant to the settings of the port for controlling event output.

*** 4005h : RAS status port**

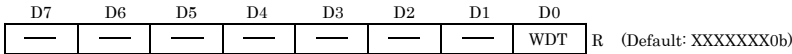

Figure 5.10 RAS Status Port (4005h)

R : RAS status port

WDT : WDT status

This is the WDT status bit. This bit is cleared when the WDT stops (read port 4002h).

0 : The WDT is either stopped or counting.

1 : The time set on the WDT expired.

General-purpose I/O and Remote Reset

The PANECON-PC is equipped with three general-purpose isolated signals each for input and output. The input signals can also be used for interrupt input or remote reset input.

Specifications

[Input]

- Input specifications : Current-driven input by Optocoupler isolation.
- Input resistance : 4.7k Ω
- Input signal count : 3 [One of them can be used for remote reset and interrupt input. (bit2<fixed>)]
- Input protection circuit : Equipped with a reverse-connection protection diode
- Input response time : Less than 100 μ sec
- External circuit power supply : 12 - 24VDC (\pm 10%)

[Output]

- Output specifications : Open-collector output by Optocoupler isolation.
- Output rating : Max. 30VDC, 100mA
- Output signal count : 3 [One of them can be used for WDT alarm output. (bit2<fixed>)]
- Output response time : Less than 300 μ sec

[Common]

- I/O addresses : 4000h and 4001h

How to Use General-purpose I/O and Remote Reset

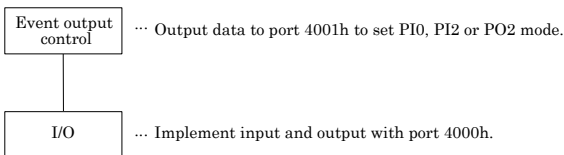

Figure 5.11. How to Use General-purpose I/O and Remote Reset

I/O Addresses and Instructions

* **4000h: General-purpose I/O**

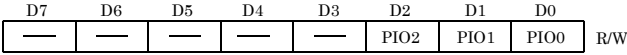

Figure 5.12. General-purpose Input Port (4000h)

R : Read data from PI0, PI1 and PI2.

W : Set data to be output to PO0, PO1 and PO2.

* **4001h (bit0-3): PI2/IRQ(14) event input control**

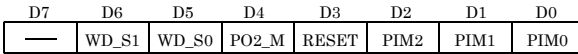

Figure 5.13. Event Input Control Port (4001h)

Table 5.24. PIM2 - PIM0

RIM2	RIM1	RIM0	PI2/IRQ (14) interrupt input
0	0	1	Input the RAS connector's PI2/IRQ (14) signal to IRQ5.
0	1	0	Input the RAS connector's PI2/IRQ (14) signal to IRQ7.
0	1	1	Input the RAS connector's PI2/IRQ (14) signal to IRQ9.
1	0	0	Input the RAS connector's PI2/IRQ (14) signal to IRQ10.
1	0	1	Input the RAS connector's PI2/IRQ (14) signal to IRQ11.
Others			Inhibit the RAS connector's PI2/IRQ (14) signal interrupt to be set.

Table 5.25. RESET: RESET: Reset Input Modes

RESET	PI2/IRQ (14)'s RESET input
0	Inhibit the remote reset input function of the RAS connector's PI2/IRQ (14) signal.
1	Use as the remote reset input function of the RAS connector's PI2/IRQ (14) signal.

⚠ CAUTION

A bit indicated with "rsv" is used by the system. Do not modify the bit.

* 4006h: Index address setting

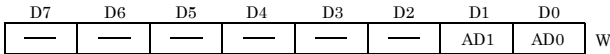

Figure 5.14. Index Address Setting Port (4006h)

W : Index address setting

When specifying the RS-485 setting with port 4007h, output 00h to this port before you specify the setting. (* Index addresses other than 00h are used by the system. Do not set addresses except for 00h.)

* 4007h: Control of RS-485 transmission and reception

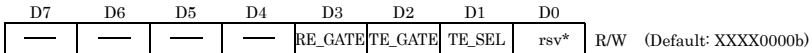

Figure 5.15. RS-485 Transmission and Reception Control Port (4007h)

TE_SEL : Select the RS-485 transmission enable signal.

0 : Sets the RTS signal to the RS-485 transmission enable signal. (factory setting)

1 : Sets the TE_GATE value to the RS-485 transmission enable signal.

TE_GATE : RS-485 transmission enable signal. Valid only when the TE_SEL value is "1."

0 : RS-485 transmission Enable (factory setting)

1 : RS-485 transmission Disable

RE_GATE : RS-485 reception enable signal.

0 : RS-485 reception Enable (factory setting)

1 : RS-485 reception Disable

⚠ CAUTION

A bit indicated with "rsv" is used by the system. Do not modify the bit.

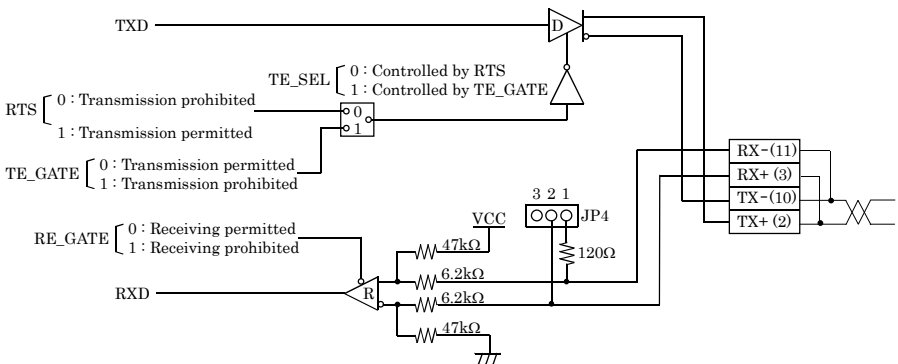

Figure 5.16. Half-Duplex Connection Method

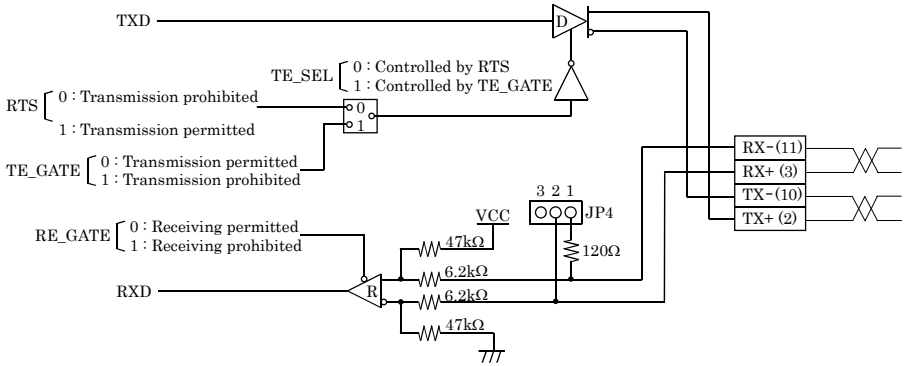

Figure 5.17. Full-Duplex Connection Method

External I/O Circuit

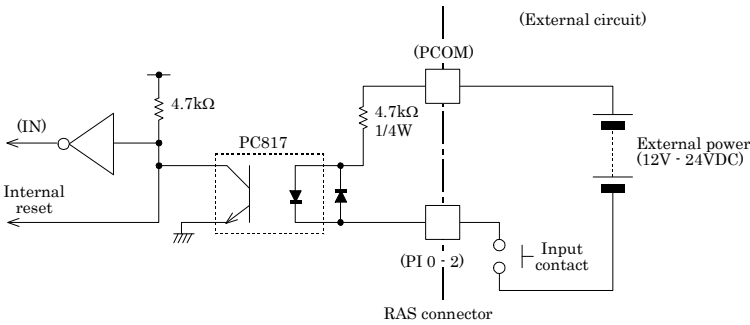

Figure 5.18. Input Circuit

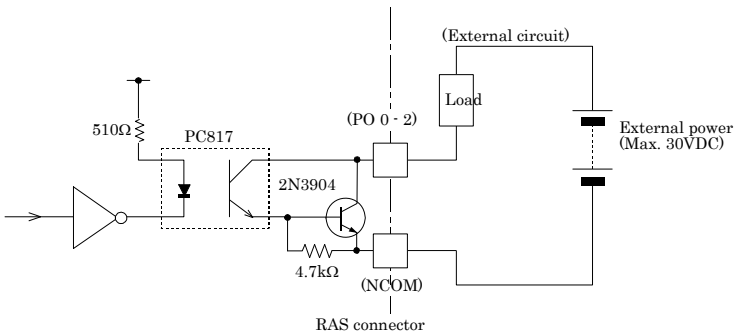
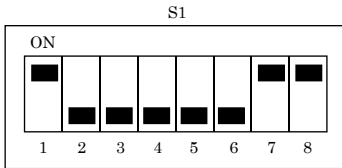

Figure 5.19. Output Circuit

S1

Leave all the S1 bits untouched as they are used by the system.

IPC-PT/L620S(PCW)C, CP



IPC-PT/H620X(PCW)C, CP

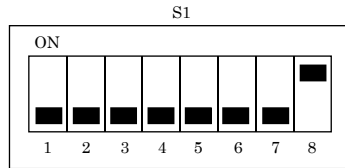

Figure 5.20. Factory Settings

Reset Switch

The PANECON-PC is equipped with a hardware reset switch. To prevent it from being pressed by mistake, the switch is designed to be difficult to press. Use a pointed object to push the switch with.

IDE Interface

Connector for the Internal Drive (Primary IDE Connector)

The PANECON-PC is equipped with an E-IDE controller to allow a 2.5inch IDE hard disk to be connected to connector CN1 on the board.

Table 5.26. Primary IDE Connector (CN15)

Connector in use		44-pin header type (2mm pitch)			
Pin No.	Signal	Direction	Pin No.	Signal	Direction
1	RESET-	Output	2	GND	-----
3	DD7	I/O	4	DD8	I/O
5	DD6	I/O	6	DD9	I/O
7	DD5	I/O	8	DD10	I/O
9	DD4	I/O	10	DD11	I/O
11	DD3	I/O	12	DD12	I/O
13	DD2	I/O	14	DD13	I/O
15	DD1	I/O	16	DD14	I/O
17	DD0	I/O	18	DD15	I/O
19	GND	-----	20	N.C.	-----
21	DDRQ	Input	22	GND	-----
23	DLOW-	Output	24	GND	-----
25	DIOR-	Output	26	GND	-----
27	IOCHRDY	Input	28	DALE	Output
29	DDACK-	Output	30	GND	-----
31	INTRQ	Input	32	N.C.	-----
33	DA1	Output	34	N.C.	Output
35	DA0	Output	36	DA2	Output
37	CSI-	Output	38	CS3-	-----
39	DACT-	Output	40	GND	-----
41	+5V	-----	42	+5V	-----
43	GND	-----	44	N.C.	-----

Secondary IDE Connector-CN2

Use the dedicated option cable to connect the option CD-ROM drive.

The cable is not intended to connect devices (such as hard disks) other than CONTEC option products.

Table 5.27. Secondary IDE Connector (CN2)

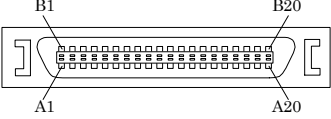
Connector in use		40pin, half-pitch type (1.27mm pitch)			
					
Pin No.	Signal	Direction	Pin No.	Signal	Direction
A1	RESET-	Output	B1	GND	-----
A2	DD7	I/O	B2	DD8	I/O
A3	DD6	I/O	B3	DD9	I/O
A4	DD5	I/O	B4	DD10	I/O
A5	DD4	I/O	B5	DD11	I/O
A6	DD3	I/O	B6	DD12	I/O
A7	DD2	I/O	B7	DD13	I/O
A8	DD1	I/O	B8	DD14	I/O
A9	DD0	I/O	B9	DD15	I/O
A10	GND	-----	B10	N.C.	-----
A11	DDRQ	Input	B11	GND	-----
A12	DIOW-	Output	B12	GND	-----
A13	DIOR-	Output	B13	GND	-----
A14	IOCHRDY	Input	B14	DALE	Output
A15	DDACK-	Output	B15	GND	-----
A16	INTRQ	Input	B16	N.C.	-----
A17	DA1	Output	B17	N.C.	-----
A18	DA0	Output	B18	DA2	Output
A19	CSI-	Output	B19	CS3-	Output
A20	DACT-	Output	B20	GND	-----

Expansion Slots (CP Model)

The CP model has two PCI/ISA bus expansion slots able to mount both PCI bus and ISA bus boards.

Board Dimensions Allowed

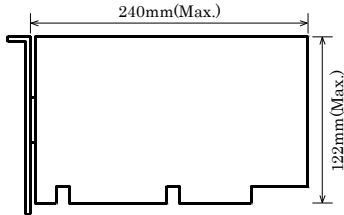

Figure 5.21. Expansion Board Dimensions

⚠ CAUTION

- A board that uses the back of the board edge connector (the shaded area in the figure) may not be mounted.
 - The following signals cannot be used on ISA bus slots.
-5V, IOCHK, REFRESH, MASTER
 - The PCI bus conforms to the 32-bit specification. The operation of dual 64-bit/32-bit boards such as the ADAPTEC 39160SCSI board or Intel Pro1000/MT network board has not been verified.
-

Power Supply to Expansion Slots

The following table lists the voltage that can be supplied to a board in an expansion slot and the total current capacity of all slot:

Table 5.28. Expansion Slots

Voltage	Current capacity (Max.)
+5V	2A
+12V	0.3A
-12V	80mA
-5V	Not supplied

⚠ CAUTION

Make sure that the total current consumption by the boards installed in the expansion slots does not exceed the above current capacity.

Board Installation Procedure

- (1) Be sure the power is turned off.
- (2) Remove the top cover.

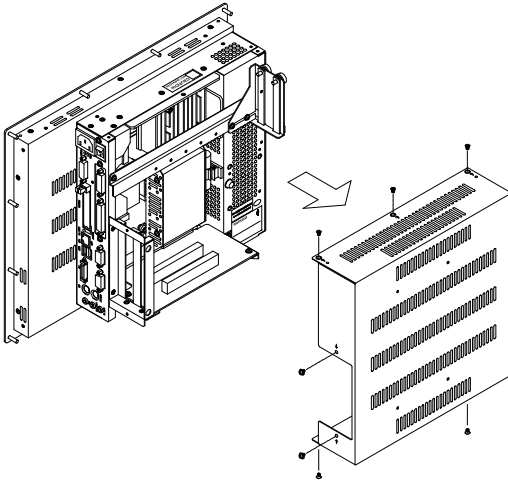
**Figure 5.22. Removing the Top Cover**

- (3) Remove the brace that holds the printed circuit board (PCB) down. Remove the screws on the brace. The brace will separate toward you.

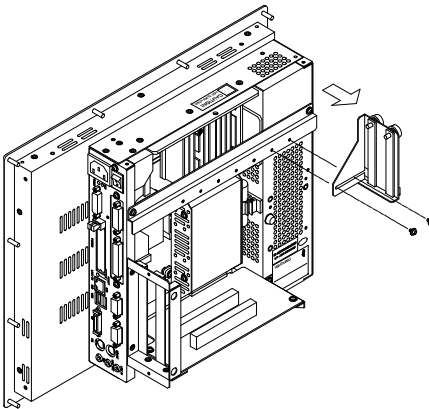
**Figure 5.23. Removing the PCB Brace 2**

- (4) Insert the board into the slot and fasten it with screws.

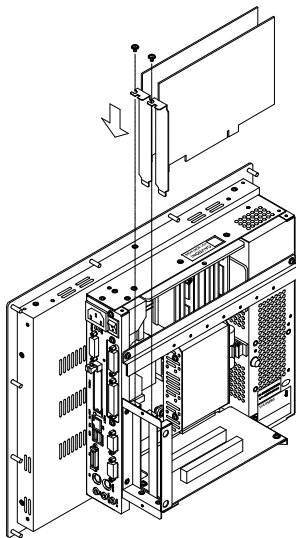

Figure 5.24. Installation of an Expansion Board

- (5) Install the PCB brace. It can hold down a board if its height is at least 68mm.

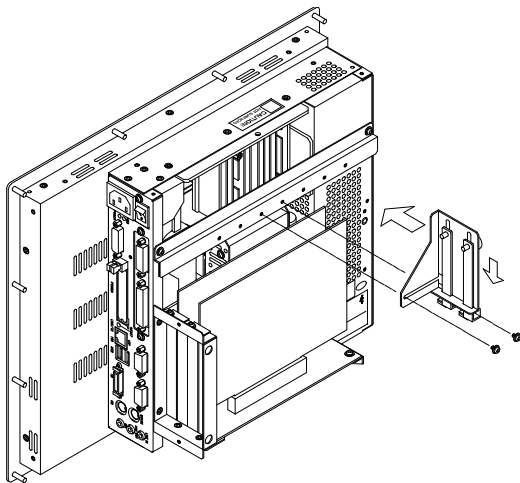

Figure 5.25. Attaching the PCB Brace

(6) Replace the expansion slot cover.

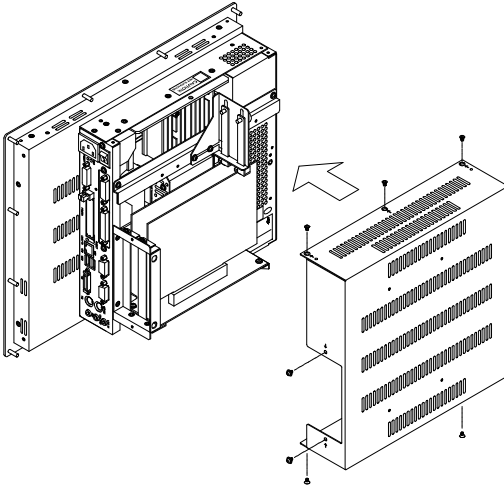

Figure 5.26. Replacing the Top Cover

6. Touch Panel

The PANECON-PC is equipped with an analog touch panel which enables keyboard-less, mouse-less operations.

Table 6.1. Touch panel specifications

Model	IPC-PT/L620S(PCW)C IPC-PT/L620S(PCW)CP	IPC-PT/H620X(PCW)C IPC-PT/H620X(PCW)CP
Detection method	Analog resistive	
Active area	246 x 184.5mm	304.1 x 228.1mm
Surface treatment	Nonglare	
Resolution	4096 x 4096 (emulated in 800 x 600 mode)	4096 x 4096 (emulated in 1024 x 768 mode)
Operating lifetime	1 million touches minimum (as tested by mechanical touching under 300g of force at a rate of two presses per second)	

Touch panel serial interface

The PANECON-PC uses a serial port (SERIAL 3) for communication with the touch panel. You can use BIOS Setup (described in Chapter 4) to assign I/O addresses and an IRQ or to disable it. (The I/O addresses or IRQ cannot be shared with any other device.)

Visit the CONTEC web site to download the touch panel driver (IPC-SLIB-01) for the OS running on your PANECON-PC.

For the download, see Chapter 7 "List of Options".

Table 6.2. SERIAL3 I/O address, interrupt

COM	I/O address	Interrupt
1	3F8h - 3FFh	IRQ 3
2	2F8h - 2FFh	IRQ 4
3	3E8h - 3EFh	IRQ 5
4	2E8h - 2EFh	IRQ 7
		IRQ 9
		IRQ 10
		IRQ 11
		IRQ 15

BIOS Default Factory Settings

Serial port C: COM3 (3E8h - 3EFh), IRQ 5

Points to note when installing the touch panel driver

1. Which Windows COM port number is allocated to the serial port used as the communication interface to the touch panel (Serial Port C)? (The standard setting is COM3.)
2. Has the display driver been installed and the LCD screen set to the maximum size? (Is the screen size set to 1024x768 for the IPC-PT/H620X(PCW) or 800x600 for the IPC-PT/L620S(PCW)?)

7. Appendix

Memory Map

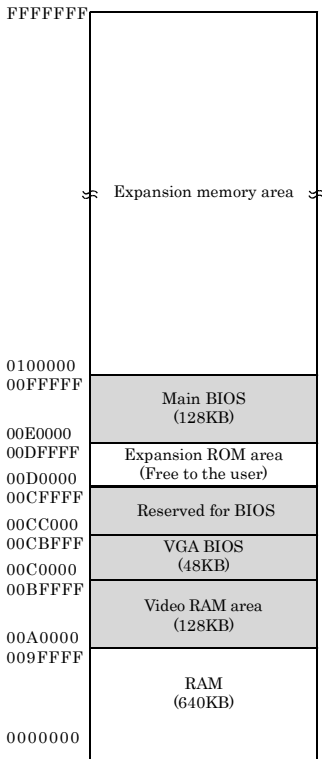

Figure 7.1. Memory Map

I/O Port Addresses

Table 7.1. I/O Port Addresses < 1 / 2 >

ADDRESS(HEX)	Description	Remark
000-00F	DMA controller 1 (slave)	ch0 - 3 (8-bit transfer)
010-01F	Reserved for system	
020-03F	Interrupt controller 1 (master)	
040-05F	Timer	
060-06F	Keyboard controller	
070-07F	RTC, NMI mask	
080-09F	DMA page register	
0A0-0BF	Interrupt controller 2 (slave)	
0C0-0DF	DMA controller 2 (master)	ch5 - 7 (16-bit transfer)
0E0-0FF	Reserved for system	
100-12F	Available to user	
140-16F	Available to user	
170-17F	IDE hard disk controller	Secondary
180-18F	Reserved for system	
190-1DF	Available to user	
1E8-1EF	Reserved for system	
1F0-1FF	IDE hard disk controller	Primary
200-277	Available to user	
278-27F	Reserved for parallel port	LPT2
280-2E7	Available to user	
2E8-2EF	Reserved for serial port	COM4(RS485, factory setting)
2F0-2F7	Available to user	
2F8-2EF	Serial port	COM2
300-35F	Available to user	
370-375	Reserved for system	
376-377	IDE hard disk controller	Secondary
378-3AF	Reserved for parallel port	LPT1 (factory setting)
3B0-3BB	Reserved for system	
3BC-3BF	Reserved for parallel port	LPT3
3C0-3DF	Reserved for system	
3E0-3E7	PCMCIA	
3E8-3EF	Serial port	COM3(Touch panel, factory setting)
3F0-3F7	FD controller	
3F8-3FF	Serial port	COM1
4D0-4DF	Reserved for system	

Table 7.1. I/O Port Addresses < 2 / 2 >

ADDRESS(HEX)	Description	Remark
CF0-CFF	Reserved for system	
4000-4007	RAS functions	
4008-400F	Reserved for system	
46E8	Reserved for system	
83D0-B3D3	Reserved for system	

Interrupt Level List

Table 7.2. Hardware Interrupt Levels (Factory Settings)

Type	8259	Priority	Description	Vector	Remarks
NMI		High	-I/O CH CK	02H	
IRQ0	MASTER	↑	Timer 0	08H	
IRQ1	MASTER		Keyboard	09H	
IRQ2	MASTER		Interrupt controller 2 (slave)	0AH	
IRQ8	SLAVE		Real-time clock	70H	
IRQ9	SLAVE		Reserved for PCI device	71H	
IRQ10	SLAVE		Not in use	72H	Available to user
IRQ11	SLAVE		Serial port D (COM4)	73H	RS-485(factory setting)
IRQ12	SLAVE		Reserved for PS/2 mouse	74H	
IRQ13	SLAVE		Reserved for coprocessor	75H	
IRQ14	SLAVE		Reserved for hard disk	76H	Primary
IRQ15	SLAVE		Reserved for optional CD-ROM	77H	Secondary
IRQ3	MASTER		Serial port B (COM2)	0BH	
IRQ4	MASTER		Serial port A (COM1)	0CH	
IRQ5	MASTER		Serial port C (COM3)	0DH	Touch panel (Default factory setting)
IRQ6	MASTER	↓	Reserved for floppy disk	0EH	
IRQ7	MASTER	Low	Parallel port	0FH	

8. List of Options

Memory for extension (144pin SO-DIMM)

- PC-MSD128-144H 128MB SD memory module
- PC-MSD256-144V 256MB SD memory module

Silicon disk drive for extension (IDE 2.5inch)

[PCI Board Type]

For IPC-PT/L620S(PCW)CP, IPC-PT/H620X(PCW)CP

- PC-RSD1000-PCI 1GB silicon disk drive
- PC-RSD2000-PCI 2GB silicon disk drive
- PC-RSD4000-PCI 4GB silicon disk drive
- PC-RSD8000-PCI 8GB silicon disk drive

Hard disk drive (IDE 2.5inch)

- PC-HDD40G 40GB hard disk drive

Silicon disk drive (IDE 2.5inch)

- PC-ESD500-A 512MB silicon disk drive
- PC-ESD1000-A 1GB silicon disk drive
- PC-ESD2000-A 2GB silicon disk drive
- PC-ESD4000-A 4GB silicon disk drive
- PC-ESD8000-A 8GB silicon disk drive
- PC-ESD500 512MB silicon disk drive
- PC-ESD1000 1GB silicon disk drive
- PC-ESD2000 2GB silicon disk drive
- PC-ESD4000 4GB silicon disk drive
- PC-ESD8000 8GB silicon disk drive

Floppy disk drive

- PC-FDD25BH 3.5inch floppy disk drive (comes with a cable)

Terminal block

- IPC-PSD-20 Terminal block for general-purpose I/O (with cable)

TFT color liquid-crystal display

<Analog RGB types>

- FPD-H21XT-AC (15 inch 1024 x 768 dots, Panel mounted type)
- FPD-L21ST-AC (12.1 inch 800 x 600 dots, Panel mounted type)
- FPD-M21VT-AC (10.4 inch 640 x 480 dots, Panel mounted type)

CD-ROM/DVD-ROM drive

- IPC-CDD-03 CD-ROM/DVD-ROM Drive Unit *3
- IPC-CDC-03 CD-ROM/DVD-ROM Drive cable

Double-sided screen protective sheets

- IPC-CV12 (12-inch screen protective sheets: 10 sheets)
- IPC-CV15 (15-inch screen protective sheets: 10 sheets)

Driver

- IPC-SLIB-01 Driver & Utility Soft Set(CD-ROM version) *1*2

Ferrite Core

- FRC2009A-6 Ferrite Core 20/09mm (6 pieces)

*1 If your PANECON-PC is an OS preinstalled model, the driver is supplied with the OS or already installed on the PC.

*2 You can download the driver from the Download Library (<http://www.contec.com/download>) on the CONTEC web site. If you need IPC-SLIB-01 (CD-ROM version), it is available as a separately priced option.

*3 Please Purchase an optional cable for connection [IPC-CDC-03].

* Check the CONTEC's Web site for the latest information on these options.

IPC-PT/H620X(PCW) Series, IPC-PT/L620S(PCW) Series User's Manual

IPC-PT/x620x(PCW)-HMU

CONTEC CO.,LTD.

October 2008 Edition

3-9-31, Himesato, Nishiyodogawa-ku, Osaka 555-0025, Japan

Japanese <http://www.contec.co.jp/>

English <http://www.contec.com/>

Chinese <http://www.contec.com.cn/>

No part of this document may be copied or reproduced in any form by any means without prior written consent of CONTEC CO., LTD. [10032008]

[04262004]

Management No. A-46-841

[10032008_rev10]

Parts No. LYDH625