



FUTV4624 DVB-T SD&HD Encoder & Modulator with USB *User Manual*



--- Home Use

Thank you for buying this encoder modulator.

Please read this manual carefully to install, use and maintain the encoder modulator in the best conditions of performance. Keep this manual for future reference.

Directory

CHAPTER 1 Product Introductions.....	3
General Description	3
Working Principle.....	3
Technical Specifications.....	4
CHAPTER 2 Safety Instruction and Installations	6
Safety Instructions	6
Installations	6
Typical Applications	7
CHAPTER 3 Operations and Management	8
CHAPTER 4 How to Upgrade.....	12
Appendix.....	13

CHAPTER 1 Product Introductions

General Description

FMUSER FUTV4624 HD&SD encoder & modulator is designed based on consumer electronics which allow audio/video signal input in TV distributions with applications in home entertainment, surveillance control, hotel Digital Signage, shops etc.

It is an all-in-one device integrating MPEG-4 AVC/H.264 encoding and modulating to convert audio/video signals into DVB-T RF out.

The signals source could be from STB, satellite receiver, closed-circuit television cameras and antenna etc. Its output signal is to be received by a DVB-T standard TVs or STBs etc.



Working Principle

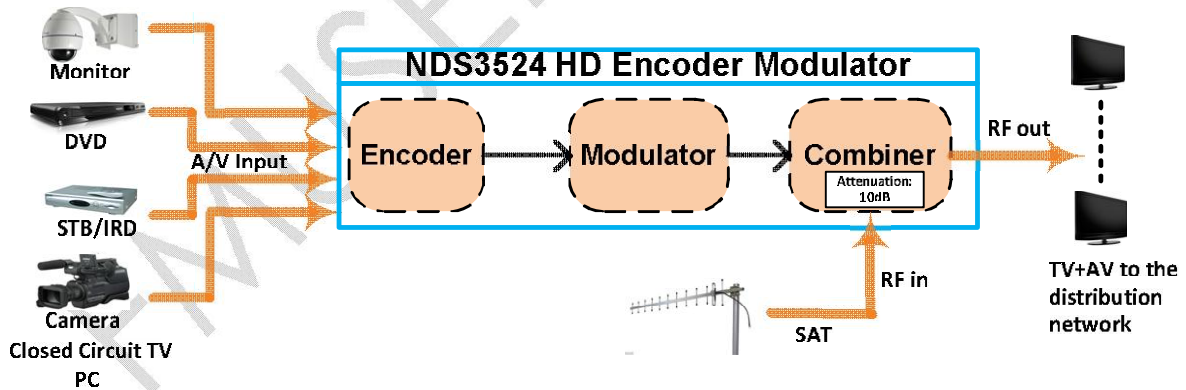

Technical Specifications

HDMI Encoding Section			
	Encoding	H.264 MP@L 3.0/3.1/4.0	
	Interface	HDMI*1	
Video		Input	Output
	Resolution	480@59.94/60p	480@60p
		480@59.94/60i	480@30p
		576@50i	576@25p
		720@50/59.94/60p	720@50/59.94/60p
		1080@50i	1080@25p
		1080@59.94/60i	1080@30p
		1080@59.94/60p	1080@30p
Aspect Ratio	16:9, 4:3		
Bit rate	1.000~18.000 Mbps		
Audio	Encoding	MPEG1 layer 2	
	Sample rate	48KHz	
	Bit rate	64, 96,128, 192, 256, 320kbps	
CVBS Encoding Section			
	Encoding	H.264 MP@L 3.0	
	Interface	CVBS*1 (RCA)	
Video		Input	Output
	Resolution	480@60p	480@60p
		480@60i	480@30p
		576@50p	576@50p
		576@50i	576@25p
Aspect Ratio	4:3		
Bit rate	1.000~18.000 Mbps		
Audio	Encoding	MPEG1 layer 2	
	Interface	Analog Stereo/Mono (Unbalanced RCA)	
	Sample rate	48KHz	
	Bit rate	64, 96,128, 192, 256, 320kbps	

DVB-T Modulator Section

Standard	DVB-T COFDM
Bandwidth	6M, 7M, 8M
Constellation	QPSK, 16QAM, 64QAM
Code rate	1/2, 2/3, 3/4, 5/6, 7/8
Guard Interval	1/32, 1/16, 1/8, 1/4
Transmission Mode:	2K, 8K
MER	31dB
RF frequency	142.5~946 MHz, 1KHz step
RF output level	-14~ +6dBm, 0.1db step

System

RF mix in ATT	10 dB
Management	Local LCD + control buttons
Language	English
LCN Insertion	yes
Upgrade	USB

General

Power supply	DC 12V
Dimensions	183*110*50mm
Weight	< 1kg

CHAPTER 2 Safety Instruction and Installations

Safety Instructions

⚠️ WARNING: Hot plug is not allowed since it may cause system halted.

To prevent fire or electrical shock, do not expose the device to rain or moisture.

✖️ The encoder modulator is powered with a voltage of 12V DC. The power supply voltage must not exceed the recommended voltage, which otherwise may cause irreparable damage to the device and the invalidation of the warranty.

Therefore:

- I Do not replace power supply with a voltage greater than 12V DC.
- I Do not connect the device to the power if the power cord is damaged.
- I Do not plug the device into mains supply until all cables have been connected correctly.
- I Do not cut the cord.

⚠️ Avoid placing the device next to central heating components and in areas of high humidity.

Do not cover the device with elements that obstruct the ventilation slots.

If the encoder modulator has been kept in cold conditions for a long time, keep it in a warm room minimum 2 hours before plugging into the mains.

Mount the device in vertical position with the connectors located on the top side.

When replacement parts are required, be sure the service technician has used replacement parts specified by the manufacturer or have the same characteristics as the original part. Unauthorized substitutes may result in fire, electric shock or other hazards.

Safety check- Upon completion of any service or repairs to this device, ask the service technician to perform safety checks to determine that the device is in proper condition.

Installations

⚠️ RISK of damage to the unit

Mechanically handling the unit may result in damage. Do not connect the unit to the power supply before or during assembly.

Connect the unit as below instructed.

⚠️ NO HOT PLUG AND CONNECT THE CABLE AS FOLLOWING STEPS.

1. Mount and tighten the screws and plugs to secure the unit to the wall. Left 10 cm of free space around from each unit.



2. Connect the signal input in the respective connectors. The signal source can be from a surveillance monitor, DVD, set-top box, CCTV and etc.
3. Optionally, connect the loop-through RF input coaxial cable.
4. Connect cable to RF output to STB/TV.
5. Power supply connection: a) Connect the earth cable; b) Connect the power plug to the unit mains connector; c) Connect the power plug to the mains socket.

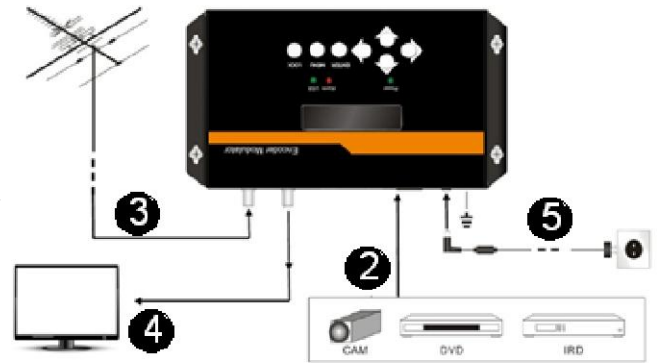

Cascade Installation

FUTV4624 unit has 1 TV signal to RF output encoded as DVB-T Digital TV signal. Several FUTV4624 units can be cascaded in order to increase the capacity. The maximum capacity of a series of N units is 1xN incorporated TV signals. To cascade 2 or more units, connect the RF output of the preceding unit to the TV input (loop-through) of the next unit (see right illustration).

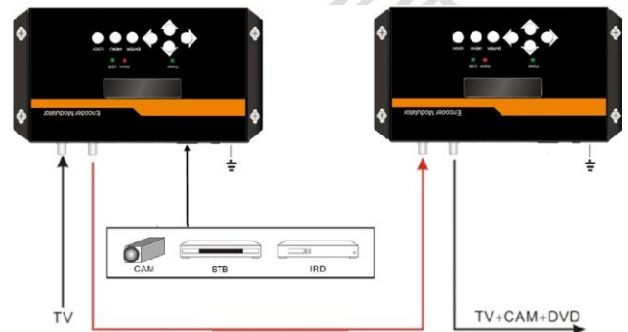

Typical Applications

...for communities of residents
an information channel on their television



...for restaurants
information about daily menus ,special deals,etc



...for hotels
meeting rooms,exhibitions,message,etc



...for hopitals
training courses, healthy guide, etc



...for Public Spaces
adversing,user information,news,etc



...for shopping centres
new collections,special deals,etc



Create your own advertising and information channel using only your FUTV4624 Encoder Modulator

CHAPTER 3 Operations and Management

FUTV4624 is controlled and managed through the key board and LCD display.

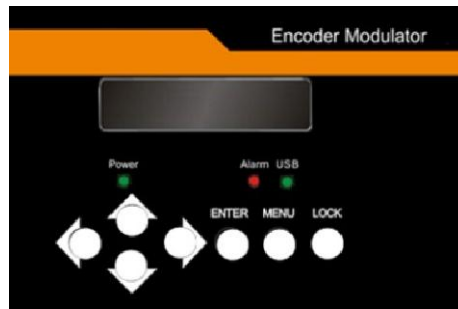

LCD Display – It presents the selected menu and the parameter settings. The backlight in the display is on when the power is applied.

LED – These lights indicate the working status

- | Power: It lights on when the power supply is connected.
- | Alarm: It lights on when there is error, such as the signal source loss.
- | USB: It lights on when the USB is properly connected and detected.

Left/Right/Up/Down buttons – Use these buttons to turn the screen pages, shift the target items by moving the triangle, or change the parameter settings in the program mode.

Enter – Use this button to enter a submenu or save a new setting after adjustment; press it to start adjusting the value of certain items with Up/Down buttons when the corresponding underline flash;

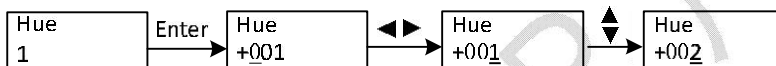

Press it to activate the hidden selections and change the setting with Up/Down (or Left/ Right) buttons.



Menu – Press this button to step back

Lock – Locking the screen / cancelling the lock state, and entering the main menu after the initialization of the device. After pressing lock key, the system will question the users to save present setting or not. If not, the LCD will display the current configuration state.

When the power is connected, the LCD will start to initialize the program. The LCD menu goes as below chart.

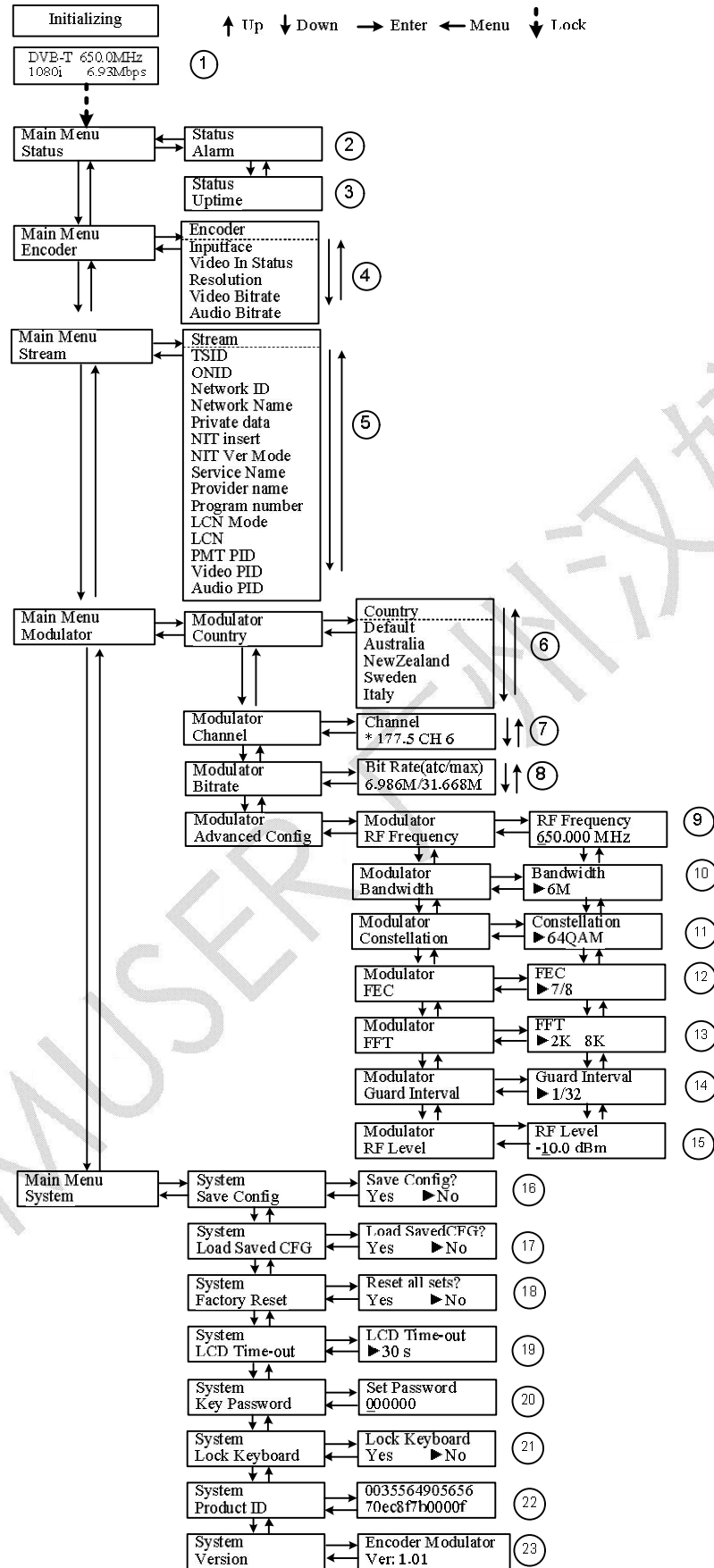

- 1) DVB-T: modulating standard; XX.XXX MHz: the current output frequency; 1080i: video resolution of signal source; X.XX Mbps: the current encoding bit rate
- 2) Alarm Status: For example, if the signals lose, it will give alarm and display error type under this menu. For example: *Video Not Lock*
- 3) Uptime: It displays the working time duration of the device. It times upon power on.
- 4) Encoder Parameters: User can enter the items respectively to set Encoder parameters. **Interface:** To select the input port (HDMI or CVBS). **Video in Status:** User can view the video status under this menu. **Resolution:** signal source resolution, read-only. **Video Bit rate:** adjust in the range of 1.000~18.000 Mbps. **Audio Bit rate:** Select audio bit rate among 64, 96, 128, 192, 256, 320kbps.
- 5) Stream: User can view or adjust TSID (Transport Stream ID), ONID (Original Network ID), Network ID, Network Name, Program number, LCN (Logical channel number) and etc for the output TS after enter this menu.
NIT: (Network Information Table) NIT table is a very important table for describing the network and TS. User can enter the submenus displayed and edit the values or select modes.
- 6) Country: User can choose country under this menu. There are five options Default, Australia, New Zealand, Sweden and Italy. If user chooses Default, modulating parameters need to be set manually through advanced configuration. If choose other four, user do not need to set RF frequency, Bandwidth, Constellation, FEC, FFT, Guard interval and RF Level. It will configure automatically according to the Country and Channel. It is a shortcut.
- 7) Channel: User can choose Channel under this submenu.
- 8) Bit Rate: User can read the current modulating bit rate and the maximum bit rate
- 9) RF Frequency: Adjust it at range of 142.5 MHz to 946MHz. Set it according your regional situation or inquire your local services.
- 10) Bandwidth: choose between 6M, 7M and 8M.
- 11) Constellation: DVB-T modulator contains 3 constellation modes – 64 QAM, QPSK and 16 QAM.
- 12) FEC: Forward Error Correction rate. It contains 1/2, 2/3, 3/4, 5/6 and 7/8.
- 13) FFT (Transmission Mode): Select between 2K and 8K.
- 14) Guard Interval: Select among 1/32, 1/16, 1/8 and 1/4.
- 15) RF Level: Adjust it at range of -14~ +6dBm.

- Ø **NOTE:** The different combination of bandwidth, constellation, guard interval and FEC (code rate) will form a different output code rate. Please refer to appendix table 2. To ensure the output image quality, it is required the output code rate to be higher than 22 MHz.
- 16) Save Config:** Yes/No-to save/give up the adjustment of setting.
- 17) Load Saved CFG:** Yes/No-to load/ not to load the saved configuration.
- 18) Factory Reset:** Yes/No-choose/not choose the factory's default configuration.
- 19) LCD Time out:** A time limit that LCD will light off. Choose among 5s, 10s, 45s, 60s, 90s and 120s (seconds).
- 20) Key Password:** to set a 6-digit password for unlocking the keyboard.
- 21) Lock Keyboard:** Choose Yes to lock the keyboard, then the keyboard will be locked and cannot be applicable. It is required to input the password to unlock the key board. This operation is one-off. (Password forgotten, please use the universal code "000000".)
- 22) Product ID:** User can view the serial number of this device. It is read-only and unique
- 23) Version:** It displays the version information of this device. *Encoder Modulator*: the name of the device; *Ver*: version number of this device.

CHAPTER 4 How to Upgrade

FUTV4624 encoder modulator is embedded with USB Port for upgrading. The supported file format is IMG.



USB Port for Upgrade

Upgrade steps: Insert USB device Upgrade automatically(it will need 10-20 seconds to upgrade.) Remove USB device Power off Power on.

Appendix

Australia Air Channels			
Ch.	Frequency		
	Start	Center	End
VHF			
C00	45	48.5	52
C01	56	59.5	63
C02	63	66.5	70
C03	85	88.5	92
C04	94	97.5	101
C05	101	104.5	108
C5A	137	140.5	144
C06	174	177.5	181
C07	181	184.5	188
C08	188	191.5	195
C09	195	198.5	202
C9A	202	205.5	209
C10	209	212.5	216
C11	216	219.5	223
C12	223	226.5	230
UHF			
C20	470	473.5	477
C21	477	480.5	484
C22	484	487.5	491
C23	491	494.5	498
C24	498	501.5	505
C25	505	508.5	512
C26	512	515.5	519
C27	519	522.5	526
C28	526	529.5	533
C29	533	536.5	540
C30	540	543.5	547
C31	547	550.5	554
C32	554	557.5	561
C33	561	564.5	568
C34	568	571.5	575
C35	575	578.5	582
C36	582	585.5	589
C37	589	592.5	596

Australia Air Channels			
Ch.	Frequency		
	Start	Center	End
C38	596	599.5	603
C39	603	606.5	610
C40	610	613.5	617
C41	617	620.5	624
C42	624	627.5	631
C43	631	634.5	638
C44	638	641.5	645
C45	645	648.5	652
C46	652	655.5	659
C47	659	662.5	666
C48	666	669.5	673
C49	673	676.5	680
C50	680	683.5	687
C51	687	690.5	694
C52	694	697.5	701
C53	701	704.5	708
C54	708	711.5	715
C55	715	718.5	722
C56	722	725.5	729
C57	729	732.5	736
C58	736	739.5	743
C59	743	746.5	750
C60	750	753.5	757
C61	757	760.5	764
C62	764	767.5	771
C63	771	774.5	778
C64	778	781.5	785
C65	785	788.5	792
C66	792	795.5	799
C67	799	802.5	806
C68	806	809.5	813
C69	813	816.5	820
C70	820	823.5	827
C71	827	830.5	834
C72	834	837.5	841
C73	841	844.5	848
C74	848	851.5	855
C75	855	858.5	862

Table 1 Australia Television Frequency/Channels (MHz)

Modulation Constellation	FEC	6MHz Bandwidth				7MHz Bandwidth				8MHz Bandwidth			
		Guard Interval				Guard Interval				Guard Interval			
		1/4	1/8	1/16	1/32	1/4	1/8	1/16	1/32	1/4	1/8	1/16	1/32
QPSK	1/2	The weak ability of error-correcting and anti-interference in this area										6.03	
	2/3				6.03	5.80	6.45	6.83	7.03	6.64	7.37	7.81	8.04
	3/4		6.22	6.58	6.78	6.53	7.25	7.68	7.91	7.46	8.29	8.78	9.05
	5/6	6.22	6.91	7.31	7.54	7.25	8.06	8.53	8.79	8.29	9.22	9.76	10.05
	7/8	6.53	7.25	7.68	7.91	7.62	8.46	8.96	9.23	8.71	9.68	10.25	10.56
16QAM	1/2	7.46	8.29	8.78	9.04	8.70	9.67	10.24	10.55	9.95	11.06	11.71	12.06
	2/3	9.95	11.05	11.70	12.06	11.61	12.90	13.66	14.07	13.27	14.75	15.61	16.09
	3/4	11.19	12.44	13.17	13.57	13.06	14.51	15.36	15.83	14.93	16.59	17.56	18.10
	5/6	12.44	13.82	14.63	15.08	14.51	16.12	17.07	17.59	16.59	18.43	19.52	20.11
	7/8	13.06	14.51	15.36	15.83	15.24	16.93	17.93	18.47	17.42	19.35	20.49	21.11
64QAM	1/2	11.19	12.44	13.17	13.57	13.06	14.51	15.36	15.83	14.93	16.59	17.56	18.10
	2/3	14.92	16.58	17.56	18.09	17.41	19.35	20.49	21.11	19.91	22.12	23.42	24.13
	3/4	16.79	18.66	19.76	20.35	19.59	21.77	23.05	23.75	22.39	24.88	26.35	27.14
	5/6	18.66	20.73	21.95	22.62	21.77	24.19	25.61	26.39	24.88	27.65	29.27	30.16
	7/8	19.59	21.77	23.05	23.75	22.86	25.40	26.89	27.71	26.13	29.03	30.74	31.67

Table 2 Recommended MPEG-2 Code Rate