

ORDERING REPLACEMENT PARTS

If you encounter any difficulties with this product, or if you need to order replacement parts, call the ICON Health & Fitness, Ltd. office, or write:

ICON Health & Fitness, Ltd.
Customer Service Department
Unit 4
Revie Road Industrial Estate
Revie Road
Beeston
Leeds, LS118JG
UK

Tel:

08457 089 009

Outside the UK: 0 (044) 113 387 7133
Fax: 0 (044) 113 387 7125

When ordering parts, please be prepared to give the following information:

- The MODEL NUMBER of the product (WEEVBE33011)
- The NAME of the product (WEIDER® PRO 435 weight bench)
- The SERIAL NUMBER of the product (see the front cover of this manual)
- The KEY NUMBER and DESCRIPTION of the part(s) (see the PART LIST and the EXPLODED DRAWING on pages 18 and 19).

WEIDER® PRO 435

USER'S MANUAL

Model No. WEEVBE33011

Serial No. _____

Write the serial number in the space above for reference.

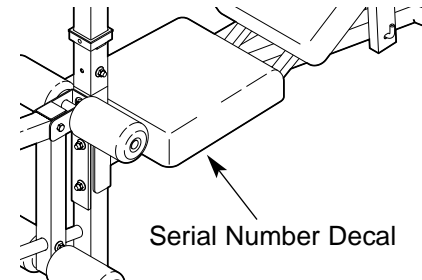

QUESTIONS?

As a manufacturer, we are committed to providing complete customer satisfaction. If you have questions, or if there are missing or damaged parts, please call:

08457 089 009

Or write:
ICON Health & Fitness, Ltd.
Customer Service Department
Unit 4
Revie Road Industrial Estate
Revie Road
Beeston
Leeds, LS118JG
UK

email: csuk@iconeurope.com

⚠ CAUTION

Read all precautions and instructions in this manual before using this equipment. Save this manual for future reference.

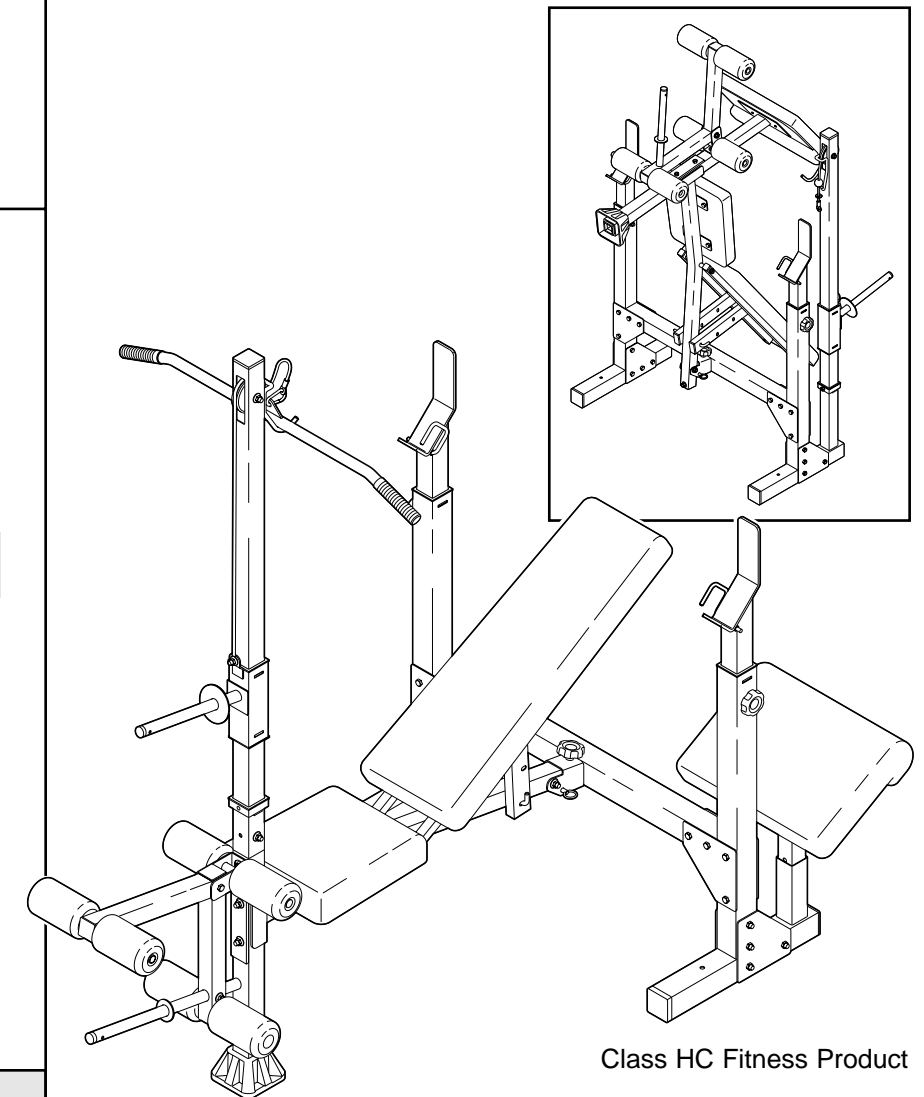

Visit our website at

www.weiderfitness.com

TABLE OF CONTENTS

WARNING DECAL PLACEMENT 2
 IMPORTANT PRECAUTIONS 3
 BEFORE YOU BEGIN 4
 PART IDENTIFICATION CHART 5
 ASSEMBLY 6
 ADJUSTMENTS 11
 EXERCISE GUIDELINES 14
 PART LIST 18
 EXPLODED DRAWING 19
 ORDERING REPLACEMENT PARTS Back Cover

WARNING DECAL PLACEMENT

The decals shown here have been placed on the weight bench. If a decal is missing or illegible, please call our Customer Service Department at 08457 089 009 to order a free replacement decal. Apply the decal in the indicated location.

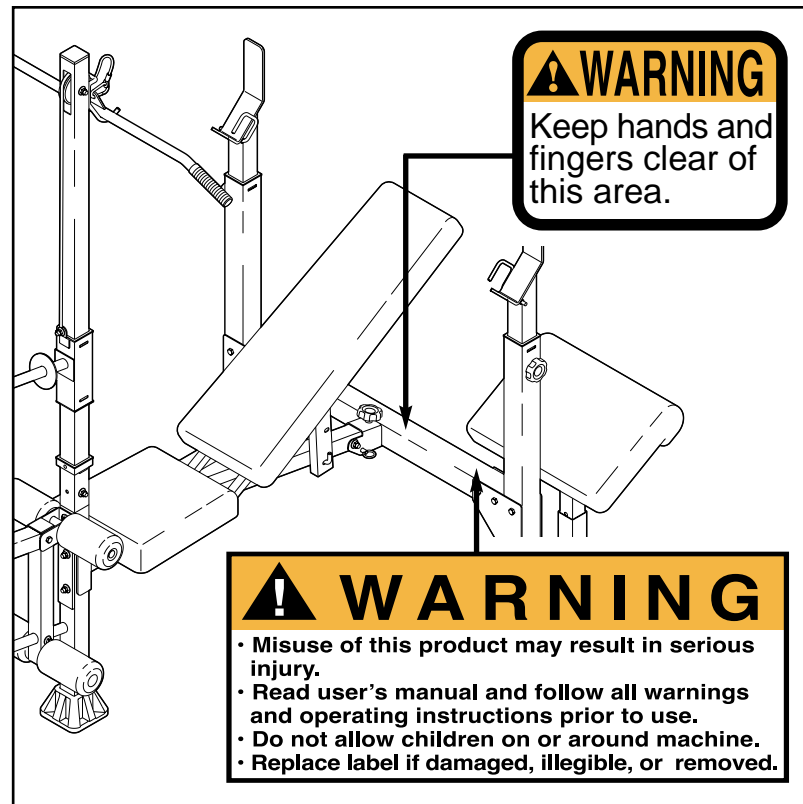

WEIDER is a registered trademark of ICON Health & Fitness, Inc.

EXPLODED DRAWING—Model No. WEEVBE33011

R0102A

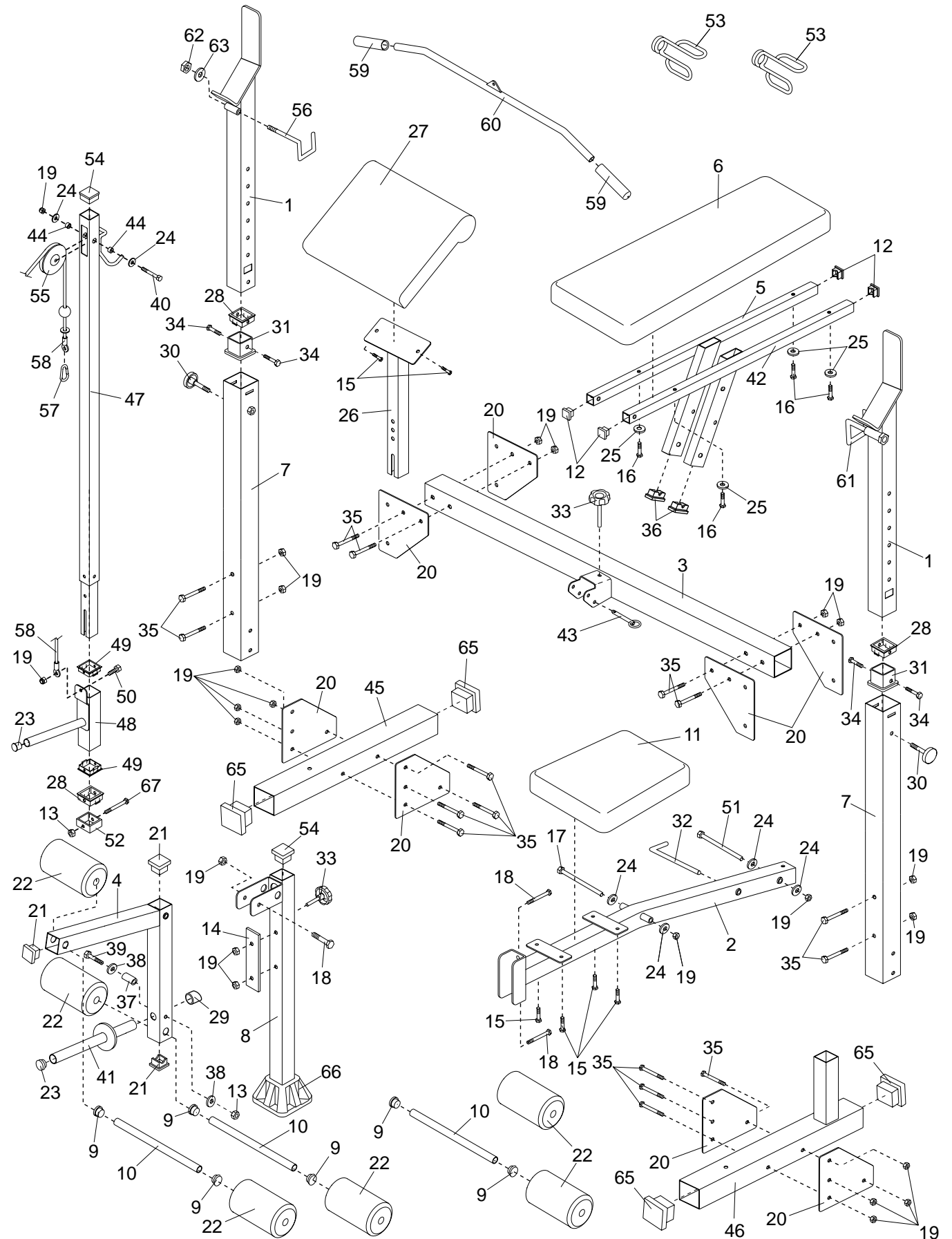

PART LIST—Model No. WEEVBE33011

R0102A

Key No.	Qty.	Description	Key No.	Qty.	Description
1	2	Upright	36	2	25mm x 50mm Inner Cap
2	1	Bench Frame	37	1	Small Spacer
3	1	Crossbar	38	2	M8 Washer
4	1	Leg Lever	39	1	M8 x 57mm Bolt
5	1	Right Backrest Frame	40	1	M10 x 65mm Bolt
6	1	Backrest	41	1	Weight Tube
7	2	Upright Base	42	1	Left Backrest Frame
8	1	Front Leg	43	1	Ring Pin
9	6	19mm Round Inner Cap	44	2	Wide Spacer
10	3	Pad Tube	45	1	Right Stabiliser
11	1	Seat	46	1	Left Stabiliser
12	4	25.4mm Square Inner Cap	47	1	Lat Tower
13	2	M8 Nylon Locknut	48	1	Weight Carriage
14	1	Support Plate	49	2	Carriage Bushing
15	6	M6 x 16mm Bolt	50	1	M10 x 20mm Bolt
16	4	M6 x 38mm Bolt	51	1	M10 x 75mm Bolt
17	1	M10 x 175mm Bolt	52	1	Carriage Stop
18	3	M10 x 67mm Bolt	53	2	Weight Clip
19	23	M10 Nylon Locknut	54	2	50mm Square Inner Cap
20	8	Joint Plate	55	1	Pulley
21	3	45mm Square Inner Cap	56	1	Right Barbell Hook
22	6	Foam Pad	57	1	Cable Clip
23	2	25.4mm Round Inner Cap	58	1	Cable
24	6	M10 Washer	59	2	Handgrips
25	4	M6 Washer	60	1	Lat Bar
26	1	Curl Post	61	1	Left Barbell Hook
27	1	Curl Pad	62	2	Bright M8 Nylon Locknut
28	3	Bushing	63	2	Bright M8 Washer
29	1	25.4mm Angled Cap	64	0	(Not Used)
30	2	M10 x 62mm Adjustment Knob	65	4	60mm Square Inner Cap
31	2	60mm x 50mm Bushing	66	1	Foot Plate
32	1	Adjustment Pin	67	1	M8 x 70mm Bolt
33	2	M10 x 57mm Adjustment Knob	#	1	User's Manual
34	4	M4 x 16mm Screw	#	1	Exercise Guide
35	16	M10 x 80mm Bolt			

Note: “#” indicates a non-illustrated part. Specifications are subject to change without notice. See the back cover of the user's manual for information about ordering replacement parts.

IMPORTANT PRECAUTIONS

⚠ WARNING: To reduce the risk of serious injury, read the following important precautions before using the weight bench.

1. Read all instructions in this manual before using the weight bench. Use the weight bench only as described in this manual.
2. It is the responsibility of the owner to ensure that all users of the weight bench are adequately informed of all precautions.
3. The weight bench is intended for home use only. Do not use the weight bench in any commercial, rental, or institutional setting.
4. Use the weight bench only on a level surface. Cover the floor beneath the weight bench to protect the floor.
5. Make sure that all parts are properly tightened each time you use the weight bench. Replace any worn parts immediately.
6. Keep children under 12 and pets away from the weight bench at all times.
7. Keep hands and feet away from moving parts.
8. Always wear athletic shoes for foot protection whilst exercising.
9. The weight bench is designed to support a maximum user weight of 115 kg (250 lbs.). Do not place more than 95 kg (210 lbs.), including a barbell and weights, on the weight rests. Do not place more than 68 kg (150 lbs.) on the leg lever. Do not place more than 59 kg (130 lbs.) on the weight carriage. Note: The weight bench does not include a barbell or weights.
10. Do not use a barbell that is longer than 1,8 m (6 ft.) with the weight bench.
11. Always make sure there is an equal amount of weight on each side of your barbell when you are using it. When adding or removing weights, always keep some weight on both ends of the barbell and prevent the barbell from tipping.
12. When you are changing weights, always secure the barbell with the barbell hooks to help prevent it from falling off the bench.
13. Always adjust the uprights to the same height before exercising.
14. When performing bench press exercises, always have a partner stand behind you to catch the barbell if you cannot complete a repetition.
15. When using the backrest in an inclined position, make sure that the adjustment pin is inserted completely through both adjustment tubes.
16. When you are using the leg lever, place a barbell with the same amount of weight on the weight rests to balance the bench.
17. Always remove the lat tower or the curl post from the front leg before performing leg curl or leg extension exercises.
18. When sitting with your back to the lat tower, make sure there is plenty of space between your back and the weight carriage. Always lower the weight carriage in a controlled manner; never let the weight carriage drop.
19. If you feel pain or dizziness whilst exercising, stop immediately and cool down.

⚠ WARNING: Before beginning this or any exercise program, consult your physician. This is especially important for persons over the age of 35 or persons with pre-existing health problems. Read all instructions before using. ICON assumes no responsibility for personal injury or property damage sustained by or through the use of this product.

BEFORE YOU BEGIN

Thank you for selecting the WEIDER® PRO 435 weight bench. The versatile WEIDER® PRO 435 is designed to be used with your own weight set (not included) to develop every major muscle group of the body. Whether your goal is a shapely figure, dramatic muscle size and strength, or a healthier cardiovascular system, the PRO 435 will help you to achieve the specific results you want.

For your benefit, read this manual carefully before using the WEIDER® PRO 435 weight bench. If you

have additional questions, please call our Customer Service Department at **08457 089 009**. To help us assist you, please mention the product model number and serial number when calling. The model number is WEEVBE33011. The serial number can be found on a decal attached to the weight bench (see the front cover of this manual).

Before reading further, please look at the drawing below and familiarise yourself with the parts that are labeled.

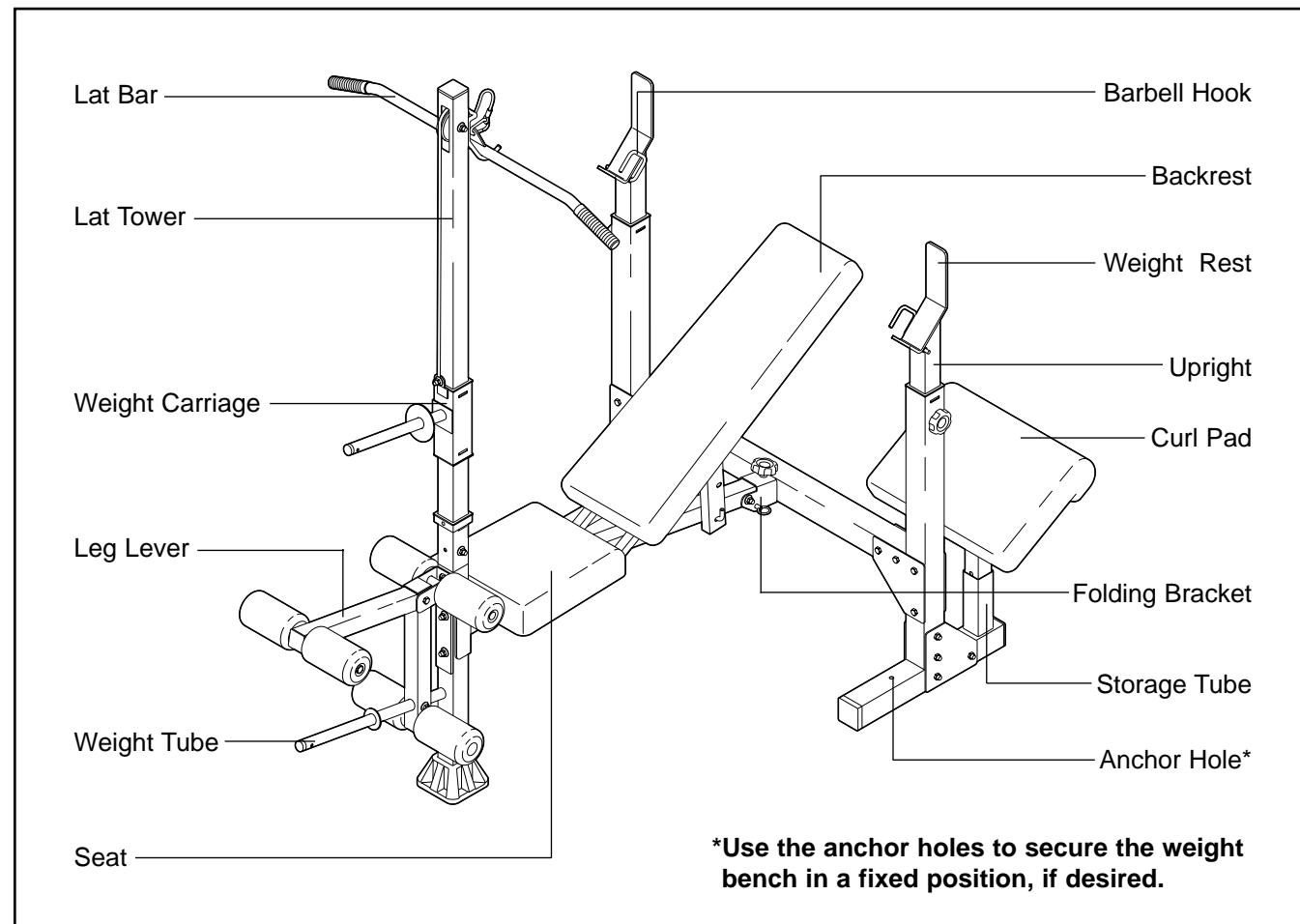

MONDAY	EXERCISE	WEIGHT	SETS	REPS
Date: / /				

TUESDAY AEROBIC EXERCISE

Date: / /

WEDNESDAY	EXERCISE	WEIGHT	SETS	REPS
Date: / /				

THURSDAY AEROBIC EXERCISE

Date: / /

FRIDAY	EXERCISE	WEIGHT	SETS	REPS
Date: / /				

Make photocopies of this page for scheduling and recording your workouts.

MONDAY	EXERCISE	WEIGHT	SETS	REPS
Date: / /				

TUESDAY AEROBIC EXERCISE
Date: / /

WEDNESDAY	EXERCISE	WEIGHT	SETS	REPS
Date: / /				

THURSDAY AEROBIC EXERCISE
Date: / /

FRIDAY	EXERCISE	WEIGHT	SETS	REPS
Date: / /				

Make photocopies of this page for scheduling and recording your workouts.

PART IDENTIFICATION CHART

This chart is provided to help you identify the small parts used in assembly. The number in parenthesis below each part refers to the key number of the part, from the PART LIST on page 18 of this manual. **Important: Some parts may have been pre-assembled. If you cannot find a part in the parts bags, check to see if it has been pre-assembled.**

M10 x 80mm Bolt (35)

M6 Washer (25)

M10 x 75mm Bolt (51)

M8 Washer (38, 63)

M8 x 70mm Bolt (67)

M10 Washer (24)

M10 x 67mm Bolt (18)

M8 Nylon Locknut (13, 62)

M10 x 65mm Bolt (40)

M10 Nylon Locknut (19)

M8 x 57mm Bolt (39)

M4 x 16mm Screw (34)

M6 x 38mm Bolt (16)

M6 x 16mm Bolt (15)

M10 x 20mm Bolt (50)

M10 x 175mm Bolt (17)

ASSEMBLY

Make Things Easier for Yourself



This manual is designed to ensure that the weight bench can be assembled successfully by anyone. Most people find that by setting aside plenty of time, assembly will go smoothly.

Before beginning assembly, carefully read the following information and instructions:

- Assembly requires two persons.
- For help identifying small parts, use the PART IDENTIFICATION CHART on page 5.
- Tighten all parts as you assemble them, unless instructed to do otherwise.
- As you assemble the weight bench, make sure all parts are oriented as shown in the drawings.

- Place all parts in a cleared area and remove the packing materials. Do not dispose of the packing materials until assembly is completed.

The following tools (not included) are required for assembly:

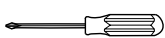
- two adjustable spanners 
- one rubber mallet 
- one standard screwdriver 
- one Phillips screwdriver 
- lubricant, such as grease or petroleum jelly, and soapy water.

Assembly will be more convenient if you have a socket set, a set of open-end or closed-end spanners, or a set of ratchet spanners.

1. Before assembling the weight bench, make sure that you have read and understand the information in the box above.

Press four 60mm Square Inner Caps (65) into the ends of the Right and Left Stabiliser (45, 46).

Attach an Upright Base (7) to the Right Stabiliser (45) with four M10 x 80mm Bolts (35), two Joint Plates (20), and four M10 Nylon Locknuts (19). **Do not tighten the Nylon Locknuts yet. Note: The welded nut on the Upright Base must be on the side shown.**

Attach an Upright Base (7) to the Left Stabiliser (46) in the same manner.

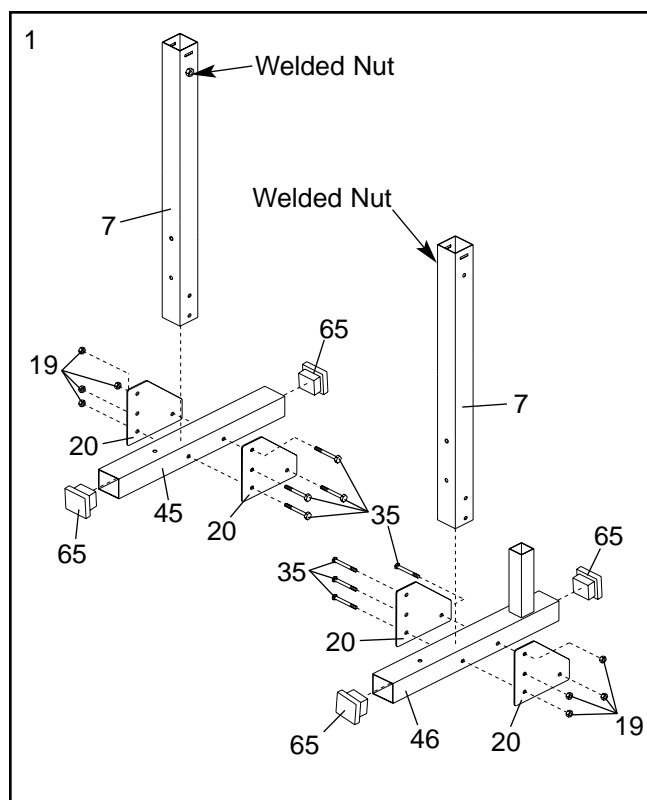

Rest for a short period of time after each set. The ideal resting periods are:

- Rest for three minutes after each set for a muscle building workout.
- Rest for one minute after each set for a toning workout.
- Rest for 30 seconds after each set for a weight loss workout.

Plan to spend the first couple of weeks familiarizing yourself with the equipment and learning the proper form for each exercise.

COOLING DOWN

End each workout with 5 to 10 minutes of stretching. Include stretches for both your arms and legs. Move

slowly as you stretch and do not bounce. Ease into each stretch gradually and go only as far as you can without strain. Stretching at the end of each workout is an effective way to increase flexibility.

STAYING MOTIVATED

For motivation, keep a record of each workout. The charts on pages 16 and 17 of this manual can be photocopied and used to schedule and record your workouts. List the date, the exercises performed, the weight used, and the numbers of sets and repetitions completed. Record your weight and key body measurements at the end of every month. Remember, the key to achieving the greatest results is to make exercise a regular and enjoyable part of your everyday life.

MUSCLE CHART

- A. Sternomastoid (neck)
- B. Pectoralis Major (chest)
- C. Biceps (front of arm)
- D. Obliques (waist)
- E. Brachioradials (forearm)
- F. Hip Flexors (upper thigh)
- G. Abductor (outer thigh)
- H. Quadriceps (front of thigh)
- I. Sartorius (front of thigh)
- J. Tibialis Anterior (front of calf)
- K. Soleus (front of calf)
- L. Anterior Deltoid (shoulder)
- M. Rectus Abdominus (stomach)
- N. Adductor (inner thigh)
- O. Trapezius (upper back)
- P. Rhomboideus (upper back)
- Q. Posterior Deltoid (shoulder)
- R. Triceps (back of arm)
- S. Latissimus Dorsi (mid back)
- T. Spinae Erectors (lower back)
- U. Gluteus Medius (hip)
- V. Gluteus Maximus (buttocks)
- W. Hamstring (back of leg)
- X. Gastrocnemius (back of calf)

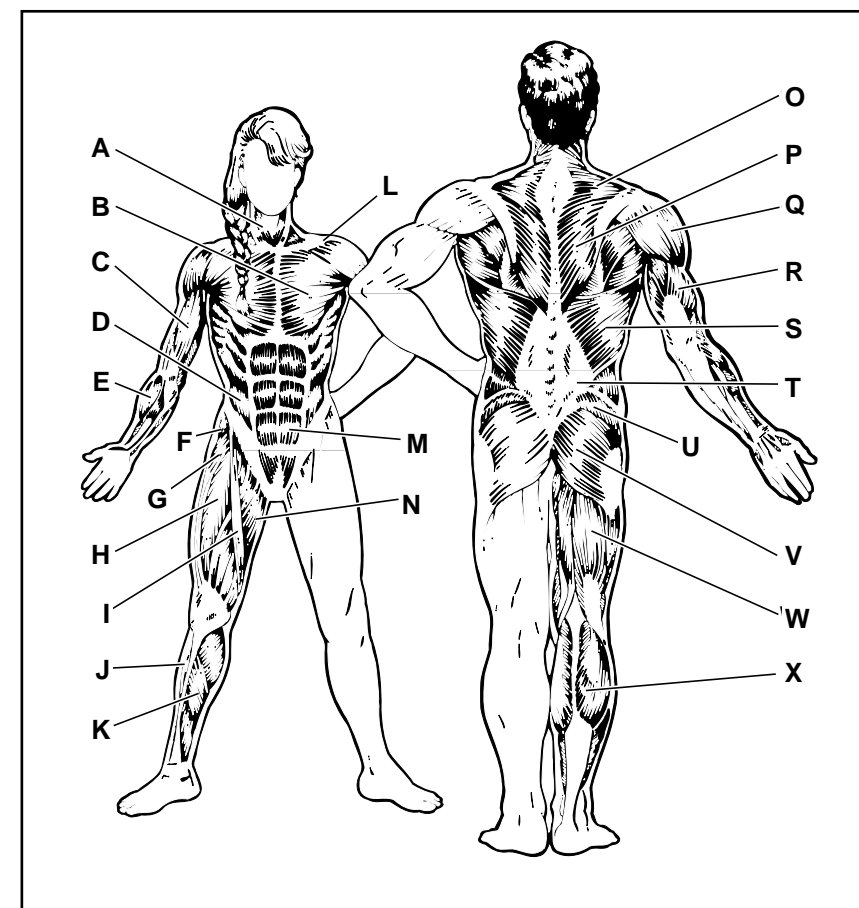

EXERCISE GUIDELINES

THE FOUR BASIC TYPES OF WORKOUTS

Muscle Building

To increase the size and strength of your muscles, push them close to their maximum capacity. Your muscles will continually adapt and grow as you progressively increase the intensity of your exercise. You can adjust the intensity level of an individual exercise in two ways:

- by changing the amount of weight used
- by changing the number of repetitions or sets performed. (A “repetition” is one complete cycle of an exercise, such as one sit-up. A “set” is a series of repetitions.)

The proper amount of weight for each exercise depends upon the individual user. You must gauge your limits and select the amount of weight that is right for you. Begin with 3 sets of 8 repetitions for each exercise you perform. Rest for 3 minutes after each set. When you can complete 3 sets of 12 repetitions without difficulty, increase the amount of weight.

Toning

You can tone your muscles by pushing them to a moderate percentage of their capacity. Select a moderate amount of weight and increase the number of repetitions in each set. Complete as many sets of 15 to 20 repetitions as possible without discomfort. Rest for 1 minute after each set. Work your muscles by completing more sets rather than by using high amounts of weight.

Weight Loss

To lose weight, use a low amount of weight and increase the number of repetitions in each set. Exercise for 20 to 30 minutes, resting for a maximum of 30 seconds between sets.

Cross Training

Cross training is an efficient way to get a complete and well-balanced fitness program. An example of a balanced program is:

- Plan weight training workouts on Monday, Wednesday, and Friday.
- Plan 20 to 30 minutes of aerobic exercise, such as cycling or swimming, on Tuesday and Thursday.
- Rest from both weight training and aerobic exercise for at least one full day each week to give your body time to regenerate.

The combination of weight training and aerobic exercise will reshape and strengthen your body, plus develop your heart and lungs.

PERSONALIZING YOUR EXERCISE PROGRAM

Determining the exact length of time for each workout, as well as the number of repetitions or sets completed, is an individual matter. It is important to avoid overdoing it during the first few months of your exercise program. You should progress at your own pace and be sensitive to your body’s signals. If you experience pain or dizziness at any time while exercising, stop immediately and begin cooling down. Find out what is wrong before continuing. Remember that adequate rest and a proper diet are important factors in any exercise program.

WARMING UP

Begin each workout with 5 to 10 minutes of stretching and light exercise to warm up. Warming up prepares your body for more strenuous exercise by increasing circulation, raising your body temperature and delivering more oxygen to your muscles.

WORKING OUT

Each workout should include 6 to 10 different exercises. Select exercises for every major muscle group, emphasizing areas that you want to develop most. To give balance and variety to your workouts, vary the exercises from session to session.

Schedule your workouts for the time of day when your energy level is the highest. Each workout should be followed by at least one day of rest. Once you find the schedule that is right for you, stick with it.

EXERCISE FORM

Maintaining proper form is an essential part of an effective exercise program. This requires moving through the full range of motion for each exercise, and moving only the appropriate parts of the body. Exercising in an uncontrolled manner will leave you feeling exhausted. On the exercise guide accompanying this manual you will find photographs showing the correct form for several exercises, and a list of the muscles affected. Refer to the muscle chart on page 15 to find the names of the muscles.

The repetitions in each set should be performed smoothly and without pausing. The exertion stage of each repetition should last about half as long as the return stage. Proper breathing is important. Exhale during the exertion stage of each repetition and inhale during the return stroke. Never hold your breath.

2. Orient the Crossbar (3) as shown. Attach the Crossbar to the left Upright Base (7) with four M10 x 80mm Bolts (35), two Joint Plates (20), and four M10 Nylon Locknuts (19). **Do not tighten the Nylon Locknuts yet. Note: If the Upright (not shown) has been preassembled, lift it out of the way of the bolts going through the Upright Base.**

Attach the Crossbar (3) to the right Upright Base (not shown) in the same manner.

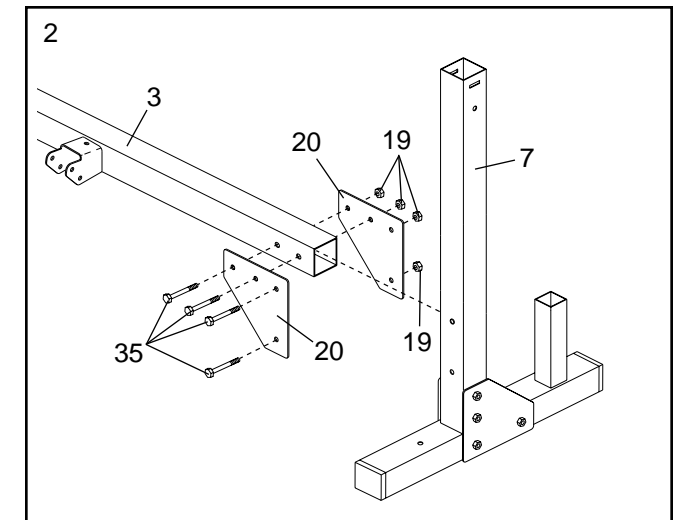

3. Press the Foot Plate (66) onto the bottom of the Front Leg (8). Press a 50mm Square Inner Cap (54) halfway into the top of the Front Leg.

Attach the Front Leg (8) to the Bench Frame (2) with two M10 x 67mm Bolts (18), the Support Plate (14), and two M10 Nylon Locknuts (19). **Do not tighten the Nylon Locknuts yet.**

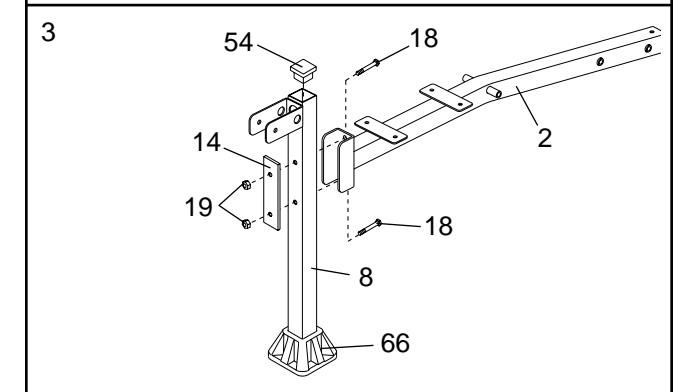

4. Lubricate an M10 x 75mm Bolt (51). Attach the Bench Frame (2) to the upper set of holes in the bracket on the Crossbar (3) with the Bolt, two M10 Washers (24), and an M10 Nylon Locknut (19). **Do not overtighten the Nylon Locknut; the Bench Frame must be able to pivot easily.**

Insert the Ring Pin (43) into the lower set of holes in the bracket on the Crossbar (3). Tighten the M10 x 57mm Adjustment Knob (33) into the Crossbar and Bench Frame (2).

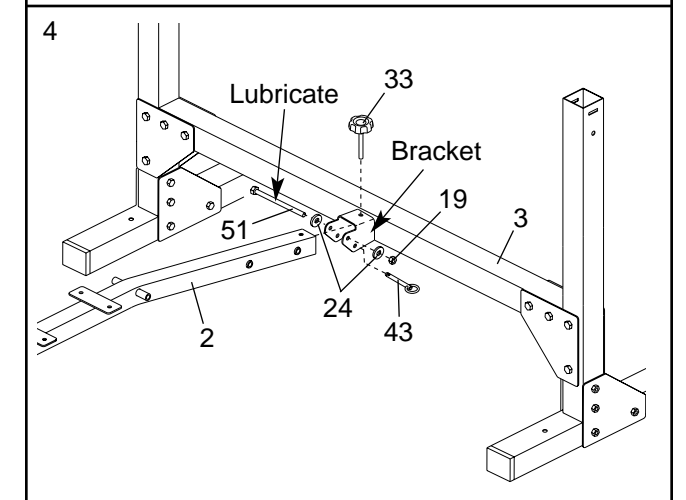

Tighten all of the M10 Nylon Locknuts (19) used in steps 1–3.

5. Press three 45mm Square Inner Caps (21) into the Leg Lever (4).

Slide the Weight Tube (41) through the Leg Lever (4) and secure it with an M8 x 57mm Bolt (39), two M8 Washers (38), a Small Spacer (37), and an M8 Nylon Locknut (13).

Press a 25.4mm Round Inner Cap (23) into the indicated end of the Weight Tube (41). Press the 25.4mm Angled Cap (29) onto the other end of the Weight Tube.

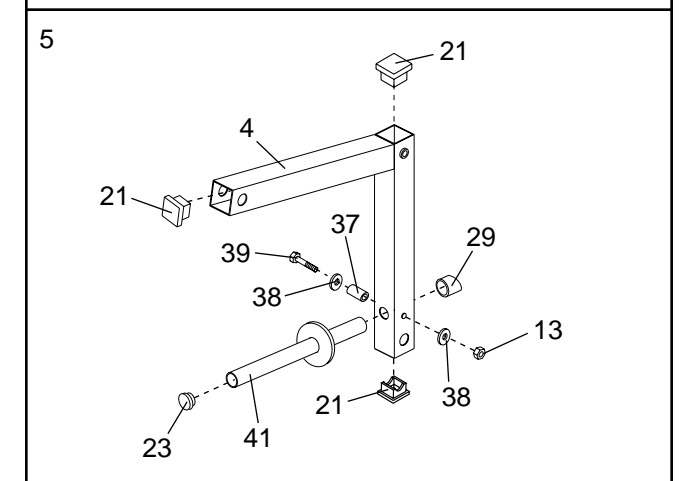

6. Lubricate an M10 x 67mm Bolt (18). Attach the Leg Lever (4) to the Front Leg (8) with the Bolt and an M10 Nylon Locknut (19). **Do not over-tighten the Nylon Locknut; the Leg Lever must be able to pivot easily.**

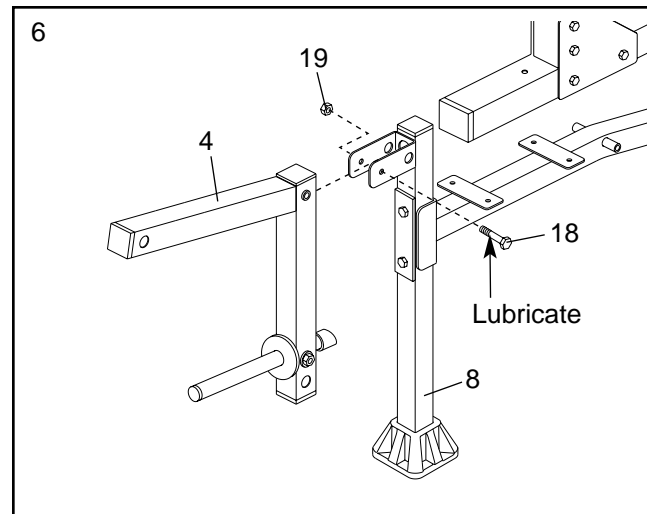

7. Identify the Right and Left Backrest Frames (5, 42) by the position of the adjustment tubes, and orient them as shown. Tap two 25.4mm Square Inner Caps (12) into the ends of each Backrest Frame. Tap a 25mm x 50mm Inner Cap (36) into the bottom of each adjustment tube.

Orient the Backrest (6) with the wide end on the side shown. Attach the Backrest to the Right and Left Backrest Frames (5, 42) with four M6 x 38mm Bolts (16) and four M6 Washers (25). **Do not tighten the Bolts yet.**

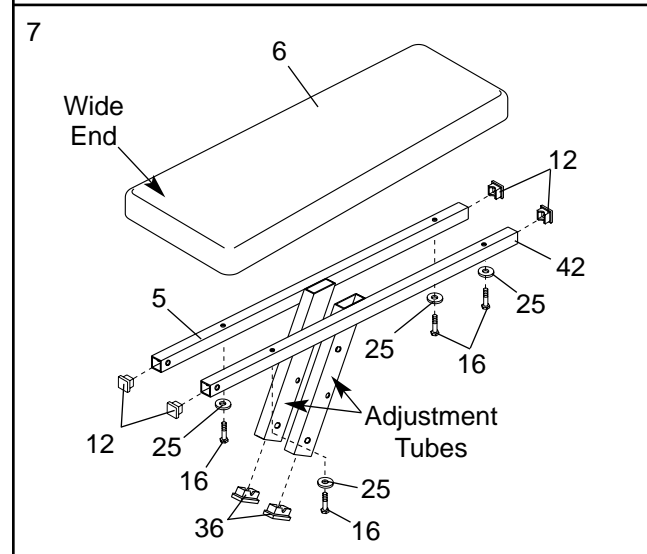

8. Lubricate the M10 x 175mm Bolt (17). Attach the Backrest Frames (5, 42) to the Bench Frame (2) with the Bolt, two M10 Washers (24), and an M10 Nylon Locknut (19). **Do not overtighten the Nylon Locknut; the Backrest (6) must be able to pivot easily.**

Secure the Backrest (6) to the Bench Frame (2) by inserting the Adjustment Pin (32) through the tube in the Bench Frame and a set of holes in the adjustment tubes. **Make sure that the Adjustment Pin is completely inserted through both adjustment tubes.**

Tighten the four M6 x 38mm Bolts (16) used in step 7.

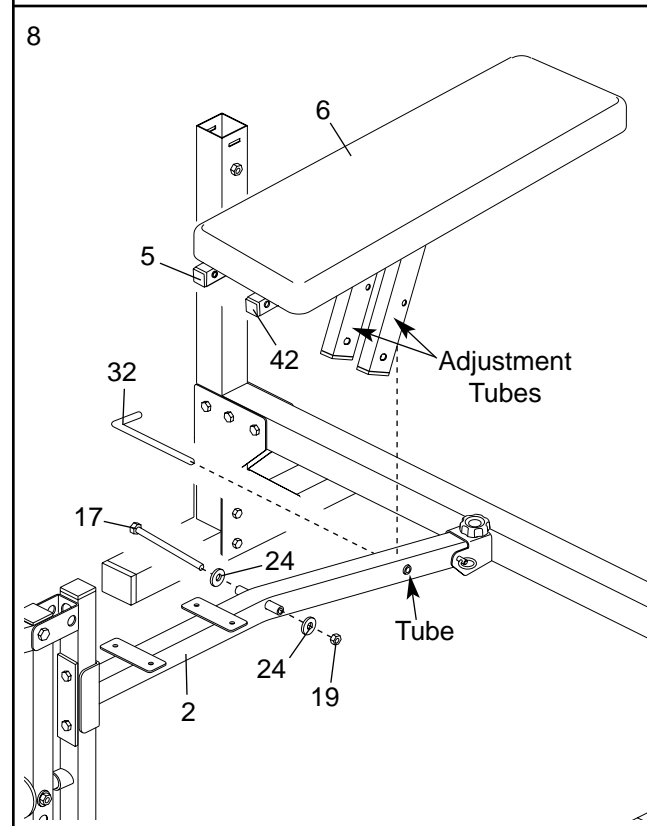

ATTACHING THE LAT BAR

Some exercises require the use of the Lat Bar (60). Attach the Lat Bar to the Cable (58) with a Cable Clip (57).

⚠ WARNING: Always remove the Lat Bar (60) when performing an exercise that does not require it.

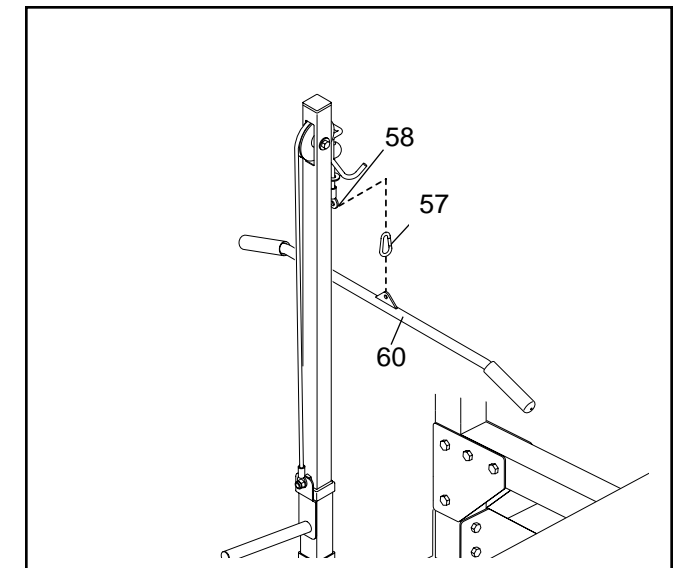

ATTACHING WEIGHTS TO THE WEIGHT CARRIAGE OR THE LEG LEVER

To use the Lat Tower (47) or the Leg Lever (4), slide the desired amount of weight (not included) onto the weight tubes of the Weight Carriage (48) or the Leg Lever. Secure the weights with the Weight Clips (53).

⚠ WARNING: Do not place more than 68 kg (150 lbs.) on the Leg Lever (4) or the Lat Tower (47).

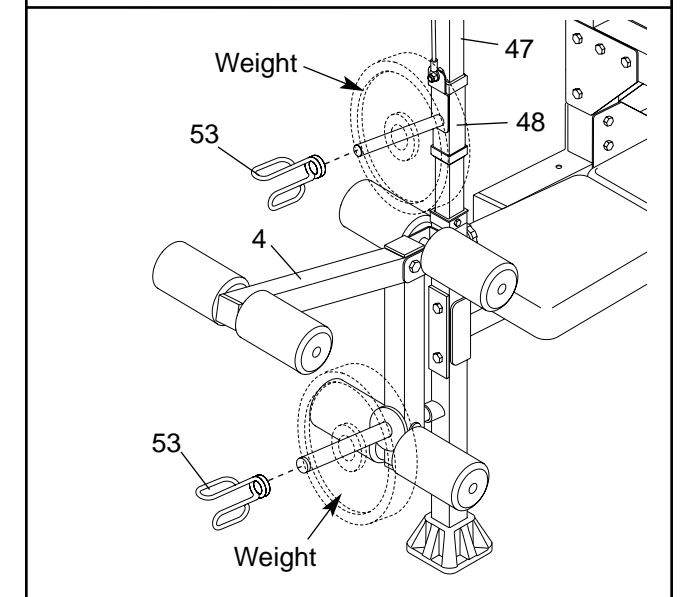

STORING THE WEIGHT BENCH

To store your weight bench, remove the M10 x 57mm Adjustment Knob (33) and the Ring Pin (43) from the Crossbar (3). Lift the Front Leg (8) as far as it will go. Reinsert the Ring Pin into the bracket on the Crossbar; the Ring Pin will prevent the bench from unfolding. **Note: The Backrest (6) must be adjusted to one of the incline positions (see ADJUSTING THE BACKREST, on page 11).**

⚠ CAUTION: To fold the weight bench, the holes in the Stabilisers (45, 46) must be at least 50 cm (20 in.) from the wall, and the Lat Bar (60) must be removed.

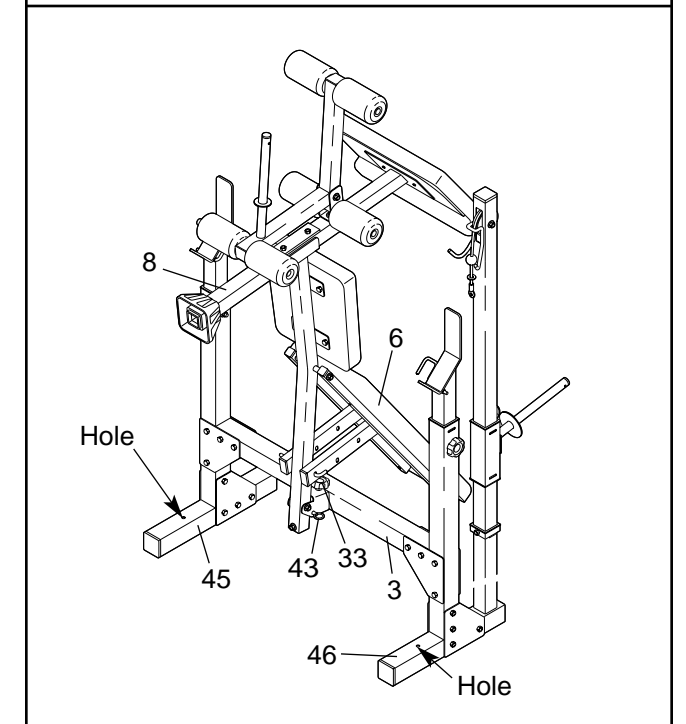

STORING THE CURL PAD AND LAT TOWER

When the Curl Pad (27) or the Lat Tower (not shown) is not in use, it can be stored in the storage tube on the Left Stabiliser (46). However, for some exercises, you should store these parts away from the weight bench so they do not interfere with your exercise.

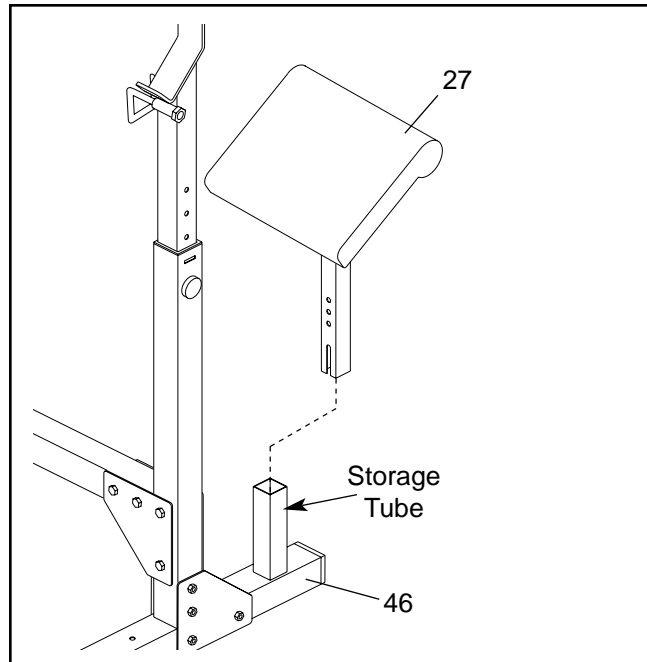

ADJUSTING THE UPRIGHTS

To adjust the Uprights (1), unscrew the M10 x 62mm Adjustment Knobs (30) and slide the Uprights to the desired position. Re-tighten the Adjustment Knobs into the Upright Bases (7) and the Uprights.

WARNING: Always set both Uprights (1) at the same height. Make sure the M10 x 62mm Adjustment Knobs (30) are fully tightened into the Upright Bases (7) and Uprights.

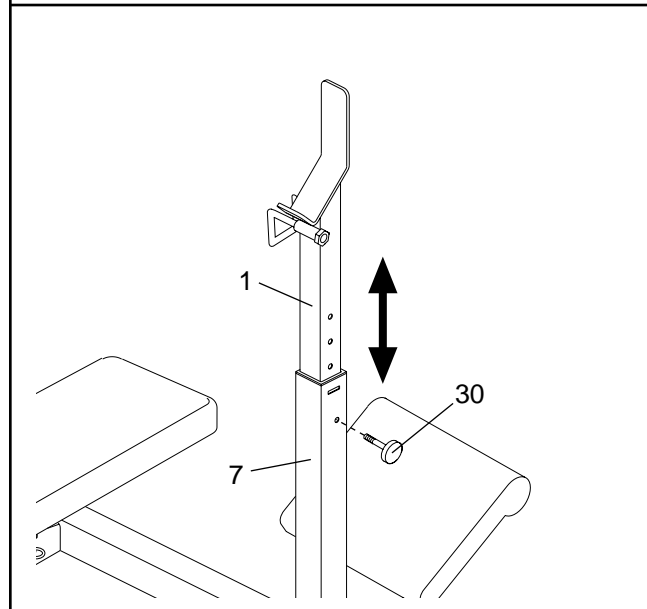

USING THE BARBELL HOOKS

To change weights while your barbell (not included) is on the Uprights (1), secure the barbell with the Barbell Hooks (56, 61 [not shown]). To do this, rotate the Barbell Hooks over the barbell. This will reduce the possibility of the barbell tipping while you are changing weights.

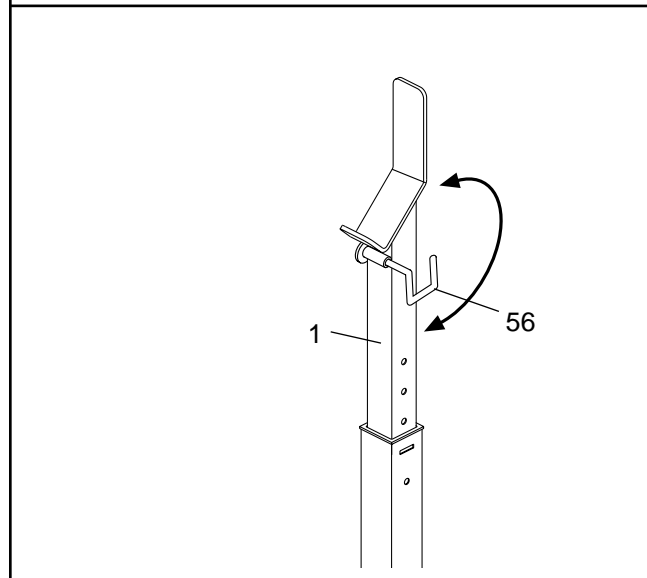

9. Orient the Seat (11) with the wide end on the side shown. Attach the Seat to the Bench Frame (2) with four M6 x 16mm Bolts (15).

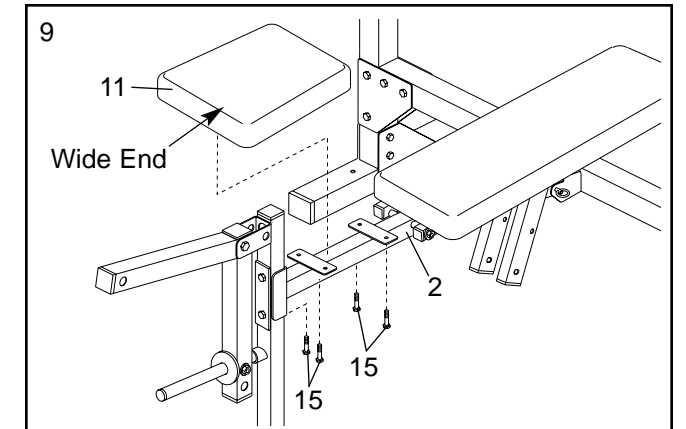

10. Insert 19mm Round Inner Caps (9) into both ends of the three Pad Tubes (10). Slide the Pad Tubes into the holes in the Leg Lever (4) and the Front Leg (8). Slide two Foam Pads (22) onto each Pad Tube.

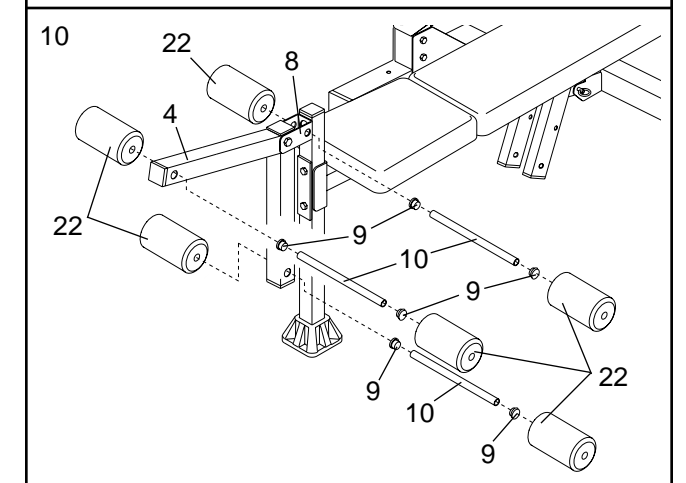

11. Slide a Bushing (28) onto the bottom of each Upright (1). **Be sure the tab is on the indicated side of the Bushing.** Press a 60mm x 50mm Bushing (31) into the bottom of each Upright and secure it with two M4 x 16mm Screws (34).

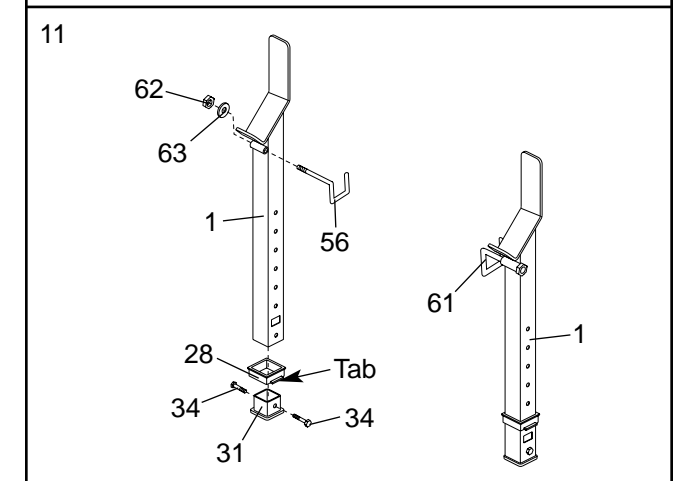

Attach the Right Barbell Hook (56) to an Upright (1) with a Bright M8 Washer (63) and a Bright M8 Nylon Locknut (62). Attach the Left Barbell Hook (61) to the other side of the other Upright in the same manner. Orient the two Uprights as shown.

12. Press the tabs on the Bushing (28) into the slots in the left Upright (1). Slide the Upright and the Bushing into the left Upright Base (7), so that the tabs snap into the slots in the Upright Base.

Note: Be careful not to pinch your fingers

Align one of the adjustment holes in the Upright (1) with the hole in the Upright Base (7). Tighten an M10 x 62mm Adjustment Knob (30) into the holes.

Attach the right Upright (1) to the right Upright Base (7) in the same manner. **Note: Always set both Uprights at the same height.**

WARNING: Do not insert the M10 x 62mm Adjustment Knob (30) through the slot in the Upright (1).

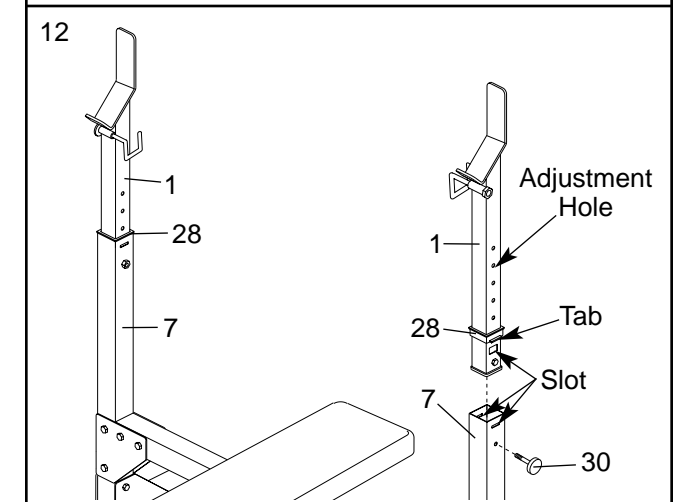

13. Attach the Curl Pad (27) to the Curl Post (26) with two M6 x 16mm Bolts (15).

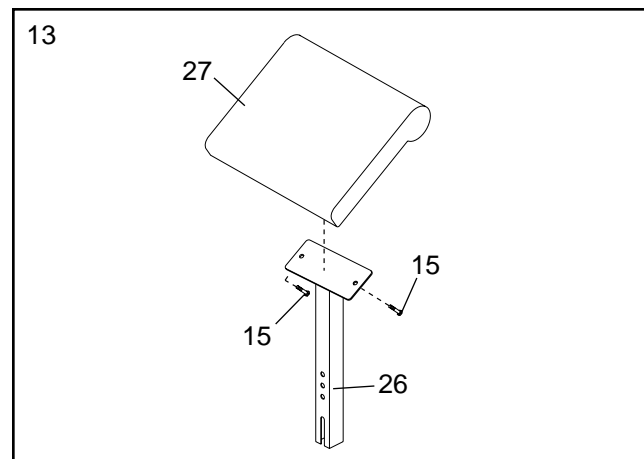

14. Press a 50mm Square Inner Cap (54) into the top of the Lat Tower (47).

Press Carriage Bushings (49) into the top and bottom of the Weight Carriage (48). Press a 25.4mm Round Inner Cap (23) into the end of the weight tube. Insert an M10 x 20mm Bolt (50) into the bracket from the direction shown.

Slide the Weight Carriage (48) onto the bottom of the Lat Tower (47) as shown.

Press a Bushing (28) into the top of the Carriage Stop (52). Attach the Carriage Stop to the indicated hole in the Lat Tower (47) with an M8 x 70mm Bolt (67) and an M8 Nylon Locknut (13).

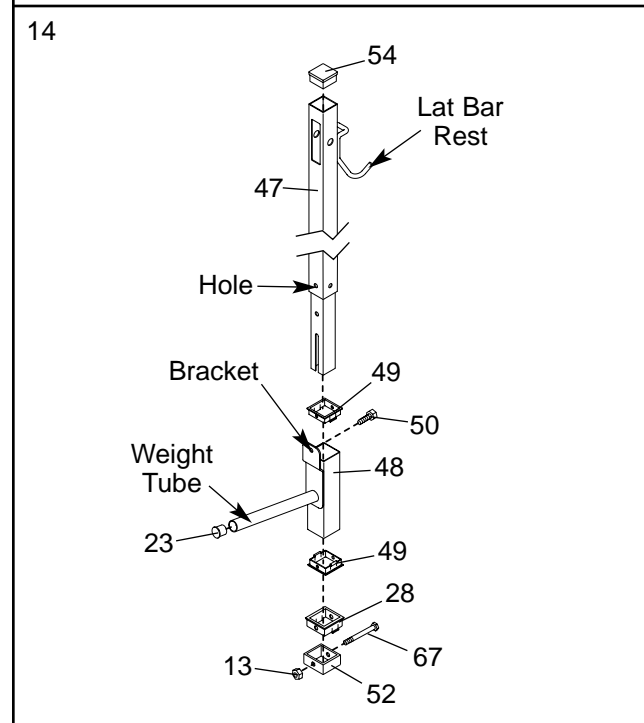

15. Find the Cable (58); note that it has a ball on one end and a loop on the other. Route the loop end of the Cable through the slot in the Lat Tower (47) and over a Pulley (55) as shown. Attach the Pulley inside the slot with an M10 x 65mm Bolt (40), two M10 Washers (24), two Wide Spacers (44), and an M10 Nylon Locknut (19).

Slide the loop on the Cable (58) onto the M10 x 20mm Bolt (50) and secure it with an M10 Nylon Locknut (19).

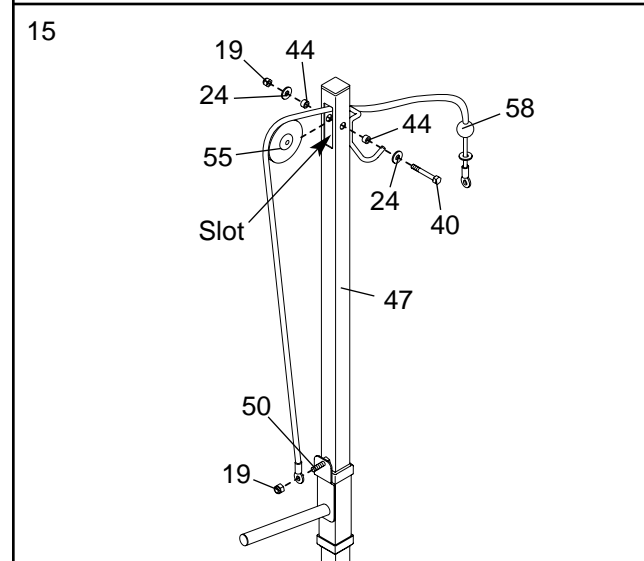

16. **Make sure that all the bolts and nylon locknuts are properly tightened before you use the weight bench.** The use of all remaining parts will be explained in ADJUSTMENTS, starting on the following page.

ADJUSTMENTS

The weight bench is designed to be used with your own weight set (not included). The steps below explain how the weight bench can be adjusted. See EXERCISE GUIDELINES on page 14 for important exercise information and refer to the accompanying exercise guide to see the correct form for several exercises. Refer also to the exercise information accompanying your weight set for additional exercises.

Make sure all parts are properly tightened each time you use the weight bench. Replace any worn parts immediately. The weight bench can be cleaned with a damp cloth and a mild, non-abrasive detergent. Do not use solvents.

ADJUSTING THE BACKREST

The Backrest (6) can be used in a decline position, a flat position, or two incline positions. To use the Backrest in the decline position, remove the Adjustment Pin (32) and lay the Backrest on the M10 x 57mm Adjustment Knob (not shown).

To use the Backrest (6) in the flat position, lift the Backrest and insert the Adjustment Pin (32) through the top set of holes in the adjustment tubes and the Bench Frame (2).

To use the Backrest (6) in an incline position, lift the Backrest and insert the Adjustment Pin (32) through one of the bottom two sets of holes in the adjustment tubes and the Bench Frame (2).

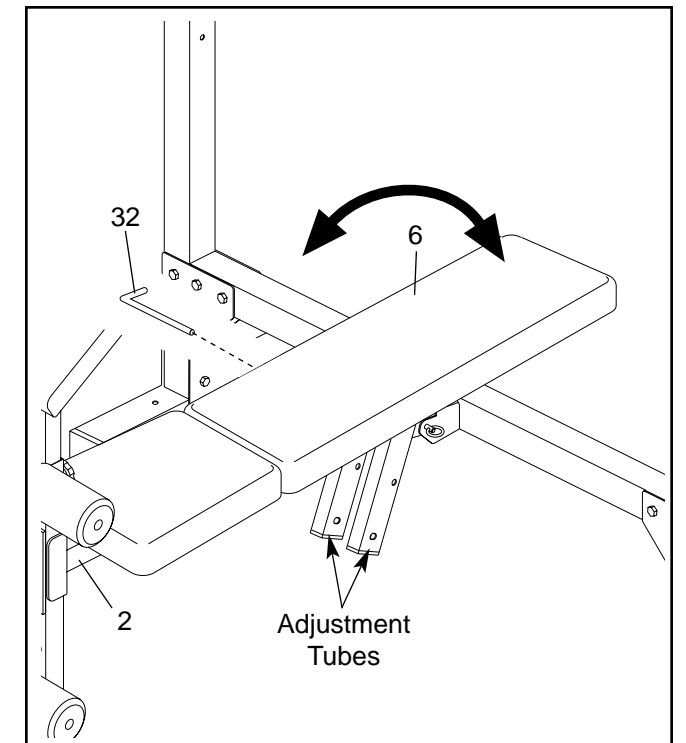

⚠ WARNING: When using the Backrest (6) in an incline or flat position, make sure that the Adjustment Pin (32) is inserted completely through both adjustment tubes and the Bench Frame (2).

ATTACHING THE LAT TOWER OR CURL PAD

For some exercises, the Lat Tower (47) must be attached to the bench. Remove the 50mm Square Inner Cap (54) from the Front Leg (8). Insert the Lat Tower into the Front Leg. Tighten the M10 x 57mm Adjustment Knob (33) into the Front Leg and the Lat Tower.

The Curl Pad (not shown) can be attached in the same manner.

⚠ WARNING: When the Lat Tower (47) or Curl Pad (27) is not in use, replace the 50mm Square Inner Cap (54). Store the Lat Tower and Curl Pad away from the bench so they will not interfere with other exercises.

