

LT2510 WIRELESS MODULE

USER MANUAL

Version 1.5

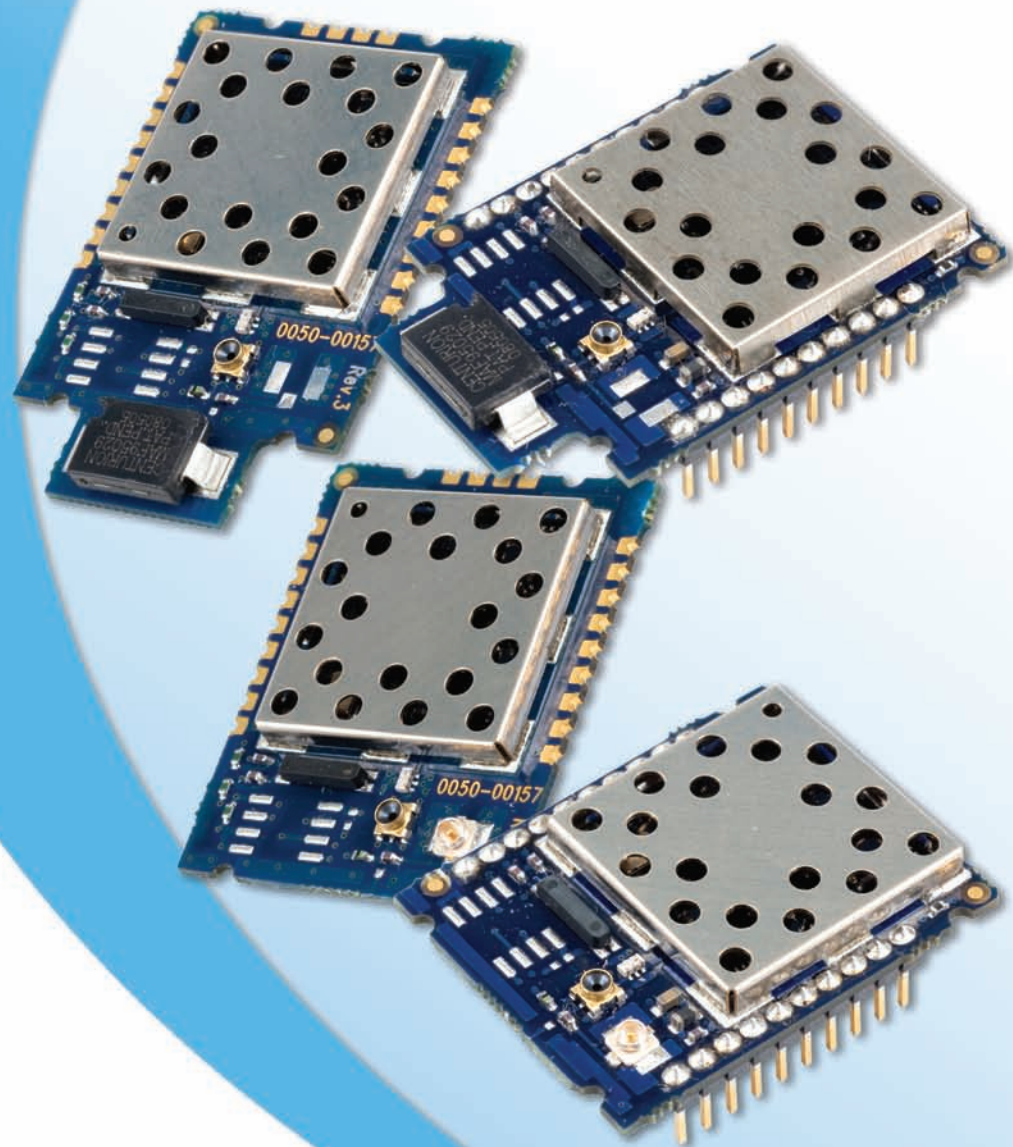

Innovative **Technology**
for a **Connected** World



Innovative Technology for a Connected World

Laird Technologies is the world leader in the design and manufacture of customized, performance-critical products for wireless and other advanced electronics applications. Laird Technologies partners with its customers to find solutions for applications in various industries such as:

- Network Equipment
- Telecommunications
- Data Communications
- Automotive Electronics
- Computers
- Aerospace
- Military
- Medical Equipment
- Consumer Electronics

Laird Technologies offers its customers unique product solutions, dedication to research and development, as well as a seamless network of manufacturing and customer support facilities across the globe.

Copyright © 2011 Laird Technologies, Inc. All rights reserved.

The information contained in this manual and the accompanying software programs are copyrighted and all rights are reserved by Laird Technologies, Inc. Laird Technologies, Inc. reserves the right to make periodic modifications of this product without obligation to notify any person or entity of such revision. Copying, duplicating, selling, or otherwise distributing any part of this product or accompanying documentation/software without the prior consent of an authorized representative of Laird Technologies, Inc. is strictly prohibited.

All brands and product names in this publication are registered trademarks or trademarks of their respective holders.

This material is preliminary

Information furnished by Laird Technologies in this specification is believed to be accurate. Devices sold by Laird Technologies are covered by the warranty and patent indemnification provisions appearing in its Terms of Sale only. Laird Technologies makes no warranty, express, statutory, and implied or by description, regarding the information set forth herein. Laird Technologies reserves the right to change specifications at any time and without notice. Laird Technologies' products are intended for use in normal commercial and industrial applications. Applications requiring unusual environmental requirements such as military, medical life-support or life-sustaining equipment are specifically not recommended without additional testing for such application.

Limited Warranty, Disclaimer, Limitation of Liability

For a period of one (1) year from the date of purchase by the OEM customer, Laird Technologies warrants the OEM transceiver against defects in materials and workmanship. Laird Technologies will not honor this warranty (and this warranty will be automatically void) if there has been any (1) tampering, signs of tampering; (2) repair or attempt to repair by anyone other than an Laird Technologies authorized technician. This warranty does not cover and Laird Technologies will not be liable for, any damage or failure caused by misuse, abuse, acts of God, accidents, electrical irregularity, or other causes beyond Laird Technologies' control, or claim by other than the original purchaser. In no event shall Laird Technologies be responsible or liable for any damages arising: From the use of product; From the loss of use, revenue or profit of the product; or As a result of any event, circumstance, action, or abuse beyond the control of Laird Technologies, whether such damages be direct, indirect, consequential, special or otherwise and whether such damages are incurred by the person to whom this warranty extends or third party. If, after inspection, Laird Technologies determines that there is a defect, Laird Technologies will repair or replace the OEM transceiver at their discretion. If the product is replaced, it may be a new or refurbished product.

REVISION HISTORY

REVISION HISTORY

Revision

Version 1.0
Version 1.0.1
Version 1.0.2
Version 1.0.3
Version 1.0.4 1
Version 1.1
Version 1.1.4-1
Version 1.1.4-2
Version 1.1.4-3
Version 1.1.4-4
Version 1.1.4-5
Version 1.1.4-6
Version 1.1.4-7
Version 1.2
Version 1.3
Version 1.4
Version 1.5

Description

07/21/08 - Initial Release Version
8/25/08 - Updated name to LT2510
10/8/08 - Changed Modulation and RF Data Rate
11/17/08 - Added TX API and Adjustable RF Data Rate
2/4/08 - Engineering Updates
03/13/09
LWS-UM-LT2510 0509
05/18/09 - LT2510 User Manual Updates
09/15/09 - Added NZH Antenna & CE
10/14/09 - LT2510 User Manual Updates and Additions
11/17/09 - LT2510 User Manual Updates and Additions
12/14/09 - LT2510 User Manual Updates and Additions
02/15/10 - LT2510 User Manual Updates and Additions
06/09/10 - LT2510 User Manual Updates and Additions
08/03/10 - Full release for FW v2.4-1
02/04/11 - Full release for FW v2.4-1
05/06/11 - Updated default parameters in manual to match those in module. Full release for FW v2.9-0

**TABLE OF
CONTENTS**

CONTENTS

LT2510 Transceiver Module	2
LT2510 Key Features	2
Overview	2
Specifications	3
Detailed Specifications	3
Pin Definitions	4
Block Diagram	5
Timing Specifications	6
Hop Frame	6
Hardware Interface	7
Pin Descriptions	7
Theory Of Operation	8
Server/Client Architecture	8
Adjustable RF Data Rate	8
Modes Of Operation	9
Serial Interface Baud Rate	10
Interface Timeout / RF Packet Size.....	10
Flow Control	12
Radio Configurations	12
EEPROM Parameters	18
Configuring The LT2510	25
AT Commands	25
Command Quick Reference	26
Command Descriptions	27
Special Firmware Upgrades	33
Overview	33
Upgrading via Windows OEM Configuration Utility	33
Upgrading FW Commands	34
Command Descriptions	35
Process to Manually Upgrade	35
API Operation	36
API Send Data Complete	36
API Receive Packet	37
API Transmit Packet	37
Mechanical Considerations	38
Mechanical Drawing	38
Mechanical Drawing	39
Mechanical Drawing	40
Mechanical Drawing	41
Moisture Content Warning	42
Ordering Information	43
Product Part Numbers	43
Compliance Information	44
Approved Antenna List	44
FCC/IC Requirements For Modular Approval	45
OEM Equipment Labeling Requirements.....	46
Antenna Requirements	46
Warnings Required In OEM Manuals	46
Regulatory Information	47
CE Approved Antenna List	47
Japan Approved Antenna List	47
Indications of Symbols on Equipment Anatel Certifications for Brazil.....	48
LT2510 Firmware History	49

OVERVIEW AND KEY FEATURES

The LT2510 Frequency Hopping Spread Spectrum Transceiver Module from Laird Technologies is the latest in robust and easy to use radio modules. Supporting both high data rates and long ranges, the LT2510 is a great fit for any number of machine to-machine applications. The LT2510 features an easy to use serial UART with hardware flow control for fast integration into an existing serial infrastructure.

KEY FEATURES

- Retries and acknowledgements
- Configurable network parameters
- Multiple generic I/O
- 280 kbps or 500kbps RF data stream
- Idle current draw of 12mA, sleep current of 50uA
- Software selectable interface baud rates from 1200 bps to 460.8 kbps
- Upgradable FW through serial port
- Low cost, low power and small size ideal for high volume, portable and battery powered applications
- All modules are qualified for Industrial temperatures (-40°C to 85°C)
- Advanced configuration available using AT commands
- Easy to use Configuration & Test Utility software

OVERVIEW

The LT2510 is available in two versions, one with 125mW conducted output power and approved for North American and similar markets and one with 50mW conducted output power and approved for European and similar markets. These modules are identical except for output power, transmit power consumption, and the number of RF Channels available. Differences between the two versions, where applicable, will be denoted based on part number.

This document contains information about the hardware and software interface between a Laird Technologies LT2510 transceiver and an OEM Host. Information includes the theory of operation, specifications, interface definitions, configuration information and mechanical drawings.

Note: Unless mentioned specifically by name, the LT2510 modules will be referred to as "radio" or "transceiver". Individual naming is used to differentiate product specific features. The host (PC/Microcontroller/Any device to which the LT2510 module is connected) will be referred to as "OEM Host" or "Host."

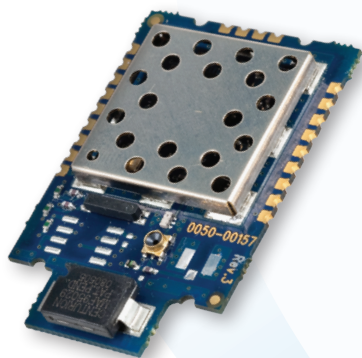

SPECIFICATIONS

TABLE 1: LT2510 DETAILED SPECIFICATIONS

GENERAL		FCC: PRM110/111/120/121	CE: PRM112/113/122/123
Form Factor	SMD-ANT, SMD-U.FL, Pluggable-ANT, Pluggable-U.FL		
Antenna	Integrated chip antenna or external antenna through U.FL connector		
Serial Interface Data Rate	Baud rates from 1200 bps to 460,800 bps. Non-standard baud rates are also supported.		
Channels	42 or 78 selectable channels	42 selectable channels	
Security	Channelization, System ID, and Vendor ID		
Minimum Flash (EEPROM) Memory Endurance	1000 Write/Erase Cycles		
TRANSCIVER			
Frequency Band	2400 - 2483.5 MHz		
RF Data Rate (Raw)	280kbps or 500kbps selectable		
Hop Bin Spacing	900kHz over 79 hops 1500kHz over 43 hops		
RF Technology	Frequency Hopping Spread Spectrum		
Modulation	MSK		
Output Power Conducted	+11 to +21dBm selectable	+8 to +17dBm selectable	
Supply Voltage	3.3 - 3.6V ± 50mV ripple		
Current Draw	100% TX	190mA	85mA
	1/8 TX (when selected)	40mA	40mA
	100% RX	40mA	40mA
	RX average (idle current)	10mA	10mA
	Deep sleep	50uA	50uA
Receiver Sensitivity (1% PER)	-98 dBm at 280kbps RF Data Rate -94 dBm at 500kbps RF Data Rate		
Range (based on external 2.5dBi antenna at 280kbps RF Data Rate)	Outdoor (line-of-sight)	2.5miles (4km)	1.5miles (2.4km)
	Indoor (estimated)	1300ft (400m)	790ft (240m)
ENVIRONMENTAL			
Operating Temperature Range	-40°C to 85°C		
Storage Temperature Range	-50°C to 150°C		
PHYSICAL			
Dimensions	SMD-ANT	1.0" x 1.54" x 0.14" (25.4mm x 39mm x 3.6mm)	
Dimensions	SMD-U.FL	1.0" x 1.28" x 0.14" (25.4mm x 33mm x 3.6mm)	
Dimensions	Pluggable-ANT	0.96" x 1.42" x 0.406" (24.3mm x 36mm x 10.3mm)	
Dimensions	Pluggable-U.FL	0.96" x 1.185" x 0.406" (24.3mm x 30.1mm x 10.3mm)	
CERTIFICATE			
FCC Part 15.247	KQL-2510100P	KQL-2510100P	
Industry Canada (IC)	2268C-2510100P	2268C-2510100P	
CE	N/A	EN 300 328-2 V1.71, EN 301 489	
RoHS	Yes	Yes	
Japan		PRM122: 005WWCA0358 PRM123: 005WWCA0359	
Brazil (Anatel)*	3000-10-6625	No	

*contact your sales representative for more details

SPECIFICATIONS

TABLE 2: PIN DEFINITIONS FOR THE LT2510 TRANSCEIVER

SMT PIN	PLUGGABLE PIN	TYPE	SIGNAL NAME	FUNCTIONS
1	7	O	GIO_0	Generic Output/Hop_Frame
2	6	O	GIO_1	Generic Output
3	8		DNC	Do not connect.
4	17	O	GIO_2	RS-485 Driver Enable
5	19	O	GIO_3	PWM Output
6	3	I	RXD	Asynchronous serial data input to transceiver
7	2	O	TXD	Asynchronous serial data output from transceiver
8	10	GND	GND	Signal Ground
9	1	PWR	Vcc	3.3 - 3.6 V ±50mV ripple (must be connected)
10	-	PWR	Vpa	3.3 - 3.6 V ±50mV ripple (must be connected)
11	-	GND	GND	Signal Ground
12	9	I	$\overline{\text{Force 9600}}$	Force 9600 – When pulled logic Low and then applying power or resetting, the transceiver’s serial interface is forced to a 9600, 8-N-1 rate. Note: Because this mode disables some modes of operation, it should not be permanently pulled Low during normal operation.
13	14	I	GIO_4	Generic Input
14	5	I	$\overline{\mu\text{P_Reset}}$	RESET – Controlled by the LT2510 for power-on reset if left unconnected. After a stable power-on reset, a logic Low pulse will reset the transceiver.
15	11	I	$\overline{\text{CMD/Data}}$	When logic Low, the transceiver interprets incoming OEM Host data as command data. When logic High, the transceiver interprets OEM Host data as transmit data.
16	15	O	$\overline{\text{In Range}}$	When logic Low, the client is in range and synchronized with a server. This will always be Low on a Server.
17	16	I	$\overline{\text{RTS}}$	Request to Send. Floats high if left unconnected. When enabled in EEPROM, the module will not transmit data out the Serial UART unless the pin is Low
18	12	O	$\overline{\text{CTS}}$	Clear to Send - CTS is used for hardware flow control. CTS will toggle high when the input buffer reaches the CTS On threshold until the buffer recedes below CTS Off.
19	18		GIO_8	Generic Input*
20	13		GIO_5	Reserved for future use. Do not connect.
21	4		GIO_6	Reserved for future use. Do not connect.
22	20	I	GIO_7	Analog to Digital Input

* Pin 18 (GIO_8) on board revisions 0050-00203 Rev 0 and 0050-00196 rev 2 (and below) is internally not connected. This pin is unavailable as a GPIO on these boards.

ENGINEER’S TIP

- All I/O is 3.3V TTL.
- All inputs are weakly pulled High via a 20kOhm pull-up resistor and may be left floating during normal operation
- Minimum Connections: VCC, VPA, GND, TXD, & RXD
- Signal direction is with respect to the transceiver
- Unused pins should be left disconnected

SPECIFICATIONS

TABLE 3: INPUT CHARACTERISTICS

SIGNAL NAME	MIN HIGH	HIGH MAX	LOW MIN	LOW MAX
UP_Reset	0.8v	Vcc	0v	0.6v
RTS	2.31v	Vcc	0v	.99v
AD_In	N/Av	Vcc	0v	N/A
All other inputs	70% Vcc	Vcc	0v	30% Vcc

TABLE 4: OUTPUT CHARACTERISTICS

SIGNAL NAME	MIN HIGH	HIGH MAX	LOW MIN	LOW MAX	SINK CURRENT
GO_0	2.5v	3.3v	0v	0.4v	20mA
GO_1	2.5v	3.3v	0v	0.4v	20mA
PWM_Output	N/A	3.3v	0v	N/A	4mA
All other inputs	2.5v	3.3v	0v	0.4v	4mA

BLOCK DIAGRAM

Figure 1 includes a functional Block Diagram of the transceiver module.

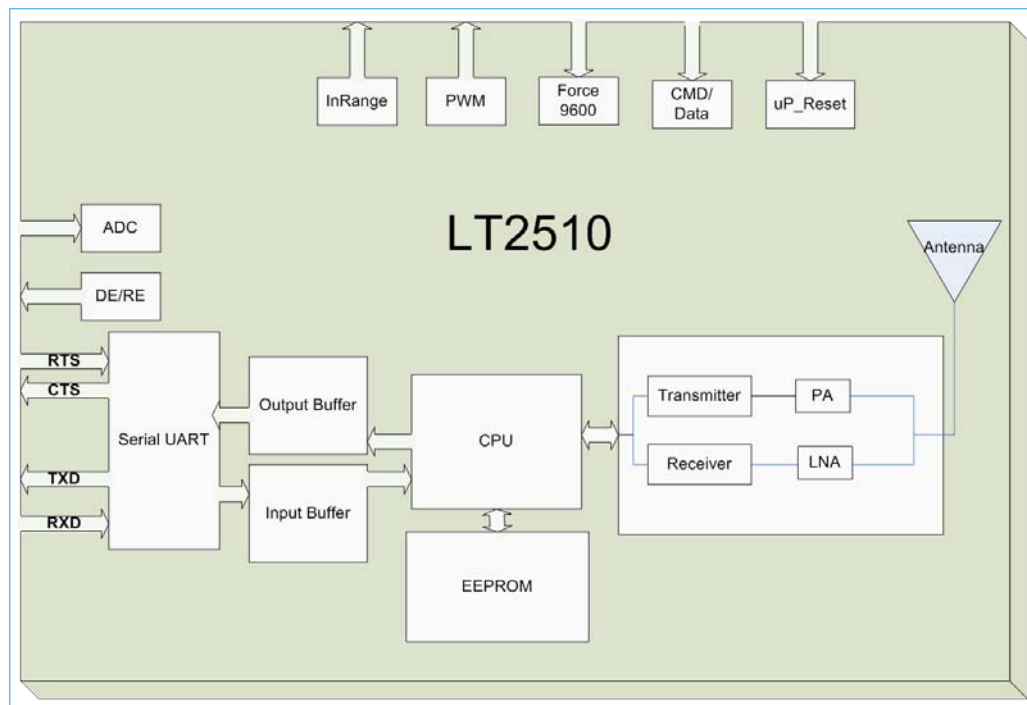

SPECIFICATIONS

TABLE 5: TIMING SPECIFICATIONS

PARAMETER	SERVER/CLIENT	MIN	TYP	MAX	NOTES
Power on to CTS Low		5ms	10ms	N/A	The first boot after a FW upgrade will require more than the typical amount of time for CTS to toggle Low.
EEPROM Read		800us	1ms	2ms	Measured from last byte of command to first byte of response: 870us for 1 byte 1.1ms for 80bytes 1.4ms for 256bytes
EEPROM Write		20ms	30ms	40ms	Measured. EEPROM writes will cause the radio to resynchronize
Power on to In Range	Client only, server will go in range in less than 13ms	13ms	600ms	1700ms*	*Maximum time assuming all beacons are heard, RF interference could extend the maximum time indefinitely
Hop Period In Range			13.19ms		
Hop Period Out of Range	Client only		38.4ms		
Reset Pulse		250ns			
PWM Output Period			315.077uS		
Restore Default EEPROM Command		10ms	38ms		Restore command also initiates a soft reset, so monitoring CTS is the best indication of a completed command
Non Specific AT Command		1ms	10ms		Some AT Commands could wait indefinitely for a response
Write Flash					For FW Upgrade
Read Flash					
Decrypt Image					

RF HOP FRAME

The LT2510 will hop every 13.19ms and can be configured for two different RF Data Rates to provide options for range or throughput. During each hop, the LT2510 reserves a certain amount of time for overhead, such as the synchronization beacon, internal messaging and user data transmission. The diagrams below outline the various transmissions that occur during a hop. These transmissions are transparent to the user sending data, but may be useful for applications that require critical timing. User data is only transmitted during the data slots and after the Interface Timeout or RF Packet Size criteria has been met. Data transmission will only begin at the beginning of a data slot. When configured for Full Duplex, data slot 1 is reserved for the Server and data slot 2 is shared by all Clients for transmissions.

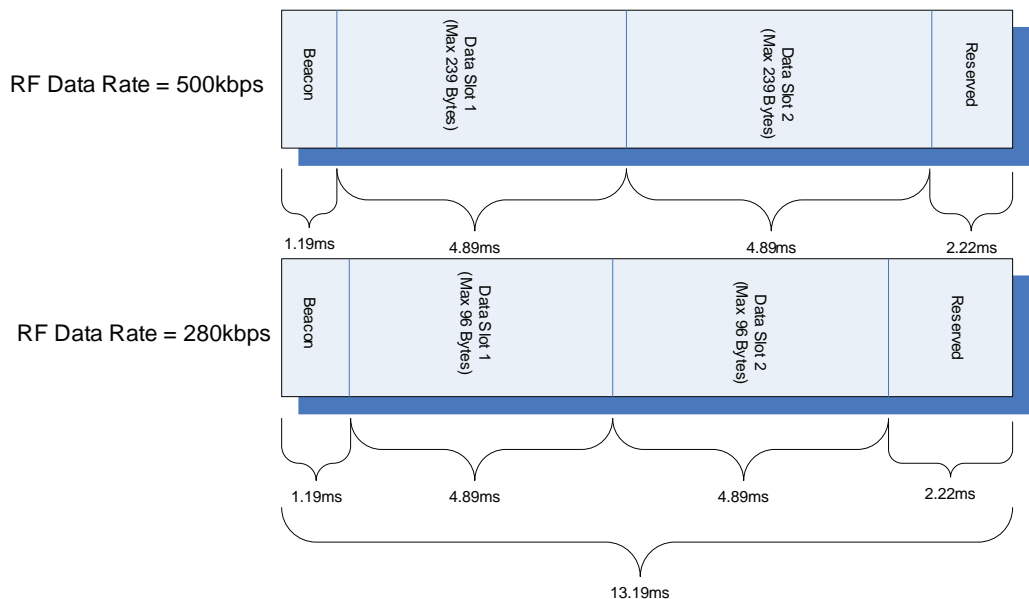

HARDWARE INTERFACE

PIN DESCRIPTIONS

RXD and TXD

The LT2510 accepts 3.3 VDC TTL level asynchronous serial data from the OEM Host via the RXD pin. Data is sent from the transceiver, at 3.3V levels, to the OEM Host via the TXD pin. Pins should be left floating or high when not in use. Leaving the RXD tied Low will result in the radio transmitting garbage serial data across the RF.

Force 9600

When pulled logic Low before applying power or resetting, the transceiver's serial interface is forced to 9600, 8-N-1 (8 data bits, No parity, 1 stop bit): regardless of actual EEPROM setting. The interface timeout is also set to 3 ms and the RF packet size is set to the default size for the selected RF Data Rate. To exit, the transceiver must be reset or power-cycled with Test pin logic High or disconnected.

When enabled in the EEPROM, 9600 Boot Option causes the 9600 pin to be ignored on cold boot (power-up), command boot (0xCC 0xFF) and brown-out conditions. Therefore, the 9600 pin is only observed on warm boots (reset pin toggled). This can be helpful so that brown-out conditions don't cause the baud rate to change if the 9600 pin happens to be Low at the time. When 9600 Boot Option is disabled, the 9600 pin will be used for all boot conditions. 9600 Boot Option is enabled by default.

Force 9600 also is used to wake the radio from sleep. When the pin is taken Low, the radio will wake. The transceiver will not sleep if the pin is Low when the sleep command is issued.

Note: Because this pin disables some modes of operation, it should not be permanently pulled Low during normal operation.

μ P_RESET

μ P_Reset provides a direct connection to the reset pin on the LT2510 microprocessor and is used to force a hard reset. For a valid reset, reset must be asserted Low for an absolute minimum of 250 ns.

Command/Data

When logic High, the transceiver interprets incoming serial data as transmit data to be sent to other transceivers. When logic Low, the transceiver interprets incoming serial data as command data. When logic Low, data packets from the radio will not be transmitted over the RF interface however incoming packets from other radios will still be received. Enabling CMD/Data RX Disable in the EEPROM will cause incoming RF packets to be queued by the receiving radio while CMD/Data is Low. When CMD/Data goes High, the data will be sent over the serial interface.

In_Range

The In Range pin will be driven Low when a Client radio's frequency hopping is synchronized with that of a Server. In Range will always be driven Low on a server. Following boot, In Range will transition Low in approximately 12ms on a Server. For a Client the In Range will take an average of 500ms, this time is dependant on the signal strength of the received beacon, the presence and strength of interference and randomness of the sync function. It can vary from 150ms to over 1500ms.

GO_0/Hop_Frame

The Hop Frame indicator functionality is disabled by default and controlled by the Control 1, Bit-6 EEPROM Setting. When enabled this pin will transition logic Low at the start of a hop and transition logic High at the completion of a hop. The OEM Host is not required to monitor Hop Frame.

RTS Handshaking

With RTS mode disabled, the transceiver will send any received data to the OEM Host as soon as it is received. However, some OEM Hosts are not able to accept data from the transceiver all of the time. With RTS enabled in EEPROM, the OEM Host can prevent the transceiver from sending it data by de-asserting RTS (High). Once RTS is re-asserted (Low), the transceiver will send packets to the OEM Host as they are received.

Note: Leaving RTS de-asserted for too long can cause data loss once the transceiver's transmit buffer reaches capacity.

CTS Handshaking

If the transceiver buffer fills up and more bytes are sent to it before the buffer can be emptied, data loss will occur. The transceiver prevents this loss by deasserting CTS High as the buffer fills up and asserting CTS Low as the buffer is emptied. CTS should be monitored by the Host device and data flow to the radio should be stopped when CTS is High.

DE/RE

When enabled, RS-485 Data Enable, will use the DE/RE pin to control the DE pin on external RS-485 circuitry. When the transceiver has data to send to the host, it will assert DE/RE High, send the data to the host, and then take DE/RE Low.

PWM Output

PWM output can be configured to output on any of three pins (SMT Pins 5, 6 or 7). The PWM Output can optionally produce a pulse width modulation for RSSI with a period of 315.077 μ s.

THEORY OF OPERATION

SERVER/CLIENT ARCHITECTURE

The LT2510 utilizes a server-client network architecture to synchronize the frequency hopping. Each network must have one radio configured as a Server and all other radios configured as Clients. When a radio is configured as a Server, it will transmit a beacon containing timing and identification information at the beginning of each hop. The beacon is never visible to the OEM host. Upon boot, radios configured as Clients will enter receive mode where they are scanning the available frequencies listening for a beacon from a Server in their network. When a Client detects the Server's beacon, the client will synchronize its frequency hopping to that of the Server and transition the InRange pin Low. When the Server and the Client are synchronized they can begin transferring data.

Each network consists of one, and only one, Server. Multiple networks can exist in the same area, provided the networks are configured on different Channels. The LT2510 utilizes an intelligent Frequency Hopping algorithm which ensures minimal interference between networks. The possible interference between collocated networks is given by the equation.

$$\text{Maximum number of interfering bins} = \# \text{ of collocated Servers} - 1$$

For example, with 10 collocated networks, there will be up to 9 bins every hop cycle that are occupied by more than one network at the same time. Although two or more networks might occupy the same hop bin at the same time, there will truly only be interference if two or more radios from alternate networks are trying to transmit on the same bin at the same time in the same coverage area.

ADJUSTABLE RF DATA RATE

The LT2510's RF data rate can be adjusted to provide a trade-off between throughput and range.

TABLE 6: RF DATA RATE

PRODUCT MODEL	RF PROFILE	RF DATA RATE	NUMBER OF HOPS	RECEIVER SENSITIVITY	THROUGHPUT ¹
PRM110, 111, 112, 113, 120, 121, 122, 123	0x00	500 kbps	43	-94 dBm	250 kbps
PRM110, 111, 120, 121	0x01	280 kbps	79	-98 dBm	120 kbps
PRM110, 111, 112, 113, 120, 121, 122, 123	0x03	280 kbps	43	-98 dBm	120 kbps

¹ Throughput is ideal, one direction, with no retransmissions. All practical RF applications should allow for the retransmission of data due to interference or less than ideal RF conditions.

Deciding which RF Data Rate to choose depends on the individual application. The fast RF Data Rate will deliver much faster throughput, but will have much less range. In addition, because the lower data rate solution uses more hops, it is better situated for collocated networks. In firmware version 1.2-5 and above the RF Data rate is set by the appropriate RF Profile, EEPROM Address 0x54.

A rule of thumb for RF systems is every 6dB of gain doubles the effective distance. The 4dB increase of Receive Sensitivity for the lower data rate solution means it will be able to transmit almost 60% farther than the higher data rate solution.

THEORY OF OPERATION

MODES OF OPERATION

The LT2510 has three different types of interface modes:

- Transparent Mode
- API Mode
- Command Mode

The first two modes are used to transmit data across the RF, the third mode is used to configure the radio.

Transparent Mode

When operating in transparent mode, the LT2510 can act as a direct serial cable replacement in which RF data is forwarded over the serial interface and vice versa. In transparent mode, the radio needs to be programmed with the MAC Address of the desired recipient. The destination address can be programmed permanently or on-the-fly.

When Transparent Mode is used, data is stored in the RX buffer until one of the following occurs:

- The RF packet size is reached (EEPROM address 0x5A)
- An Interface Timeout occurs (EEPROM address 0x58)

All parameters can be configured by entering Command Mode using either AT commands or by toggling the Command/Data pin Low on the transceiver.

Transparent Mode is the default radio operation mode.

API Modes

API Mode is an alternative to the default Transparent operation of the LT2510 and provides dynamic packet routing and packet accounting abilities to the OEM Host without requiring extensive programming by the OEM Host. API Mode utilizes specific frame-based packet formats; specifying various vital parameters used to control radio settings and packet routing on a packet-by-packet basis. The API features can be used in any combination that suits the OEM's application specific needs.

The LT2510 has three API functions:

- Transmit API
- Receive API
- Send Data Complete

For additional details and examples, please refer to the API section of the manual.

Command Mode

Command Mode is used to configure and poll for status of the transceiver. Command mode can be entered by issuing the Enter AT Command string or by setting the CMD/Data pin Low. Details of using Command Mode to configure the LT2510 are detailed in Configuring the LT2510 section.

THEORY OF OPERATION

SERIAL INTERFACE BAUD RATE

In order for the OEM Host and a transceiver to communicate over the serial interface they need to have the same serial data rate. This value determines the baud rate used for communicating over the serial interface to a transceiver. For a baud rate to be valid, the calculated baud rate must be within ±3% of the OEM Host baud rate

TABLE 7: BAUD RATE/INTERFACE TIMEOUT

DESIRED BAND RATE	BAUD (0x42)	MINIMUM INTERFACE TIMEOUT ¹ (0x58)
230,400	0x0A	0x02
115,200 ²	0x09	0x02
57,600	0x08	0x02
38,400	0x07	0x02
28,000	0x06	0x03
19,200	0x05	0x05
14,400	0x04	0x07
9,600	0x03	0x10
4,800	0x02	0x15
2,400	0x01	0x2A
1,200	0x00	0x53
Non-standard	0xE3	Use equation below

1 Interface Timeout = 200uS per increment, the EEPROM address 0x58 is ignored if Auto Config is enabled. To use a non-standard Interface Timeout, disable Auto Config.
 2 Default baud rate.

For baud rates other than those shown in Table 7 the following equations can be used:

$$\text{Baud Rate} = \frac{(256 + \text{BAUD_M}) * (2^{\text{BAUD_E}}) * \text{FREQUENCY}}{2^{28}}$$

Where:

FREQUENCY = 26 MHz
 BAUD_M = EEPROM Address 0x43
 BAUD_E = EEPROM Address 0x44

$$\text{Minimum Interface Timeout} = \frac{100,000}{\text{Baud Rate}}$$

ENGINEER'S TIP

- The LT2510 supports a majority of standard as well as non-standard baud rates. To select a standard baud rate, use the value shown for EEPROM address 0x42 in Table 7 above. To enable a non-standard baud rate, program EEPROM address 0x42 (Custom Baud Enable) to 0xE3 and then use the equation above to solve for BAUD_M and BAUD_E.
- Adjusting the Serial Interface Baud Rate does not affect the RF data rate.
- Radio can accept Serial combinations (number of bits, Parity, Number of Stop Bits) of 8-N-1, 7-N-2, 7-1-1, by Default. Modes of 8-1-1, 8-N-2, 7-1-2 are acceptable with 9-bit mode enabled.

INTERFACE TIMEOUT/RF PACKET SIZE

Interface Timeout

Interface Timeout specifies a maximum byte gap between consecutive bytes. When that byte gap is exceeded, the bytes in the transmit buffer are processed as a complete packet. Interface Timeout (EEPROM address 0x58), in conjunction with the RF Packet Size, determines when a buffer of data will be sent out over the RF as a complete RF packet, based on whichever condition occurs first. Interface Timeout is adjustable in 200us increments and should be equal to or greater than two full bytes times. The minimum Interface Timeout is 0x02.

The radio will use the default Interface Timeout for a given baud rate if Auto Config is enabled, despite what is written in the Interface Timeout address. To use a non-standard Interface Timeout, the OEM would need to disable Auto Config.

THEORY OF OPERATION

RF Packet Size

RF Packet Size is used in conjunction with Interface Timeout to determine when to delineate incoming data as an entire packet based on whichever condition is met first. When the transceiver receives the number of bytes specified by RF Packet Size (EEPROM address 0x5A) without experiencing a byte gap equal to Interface Timeout, that block of data is processed as a complete packet. Every packet the transceiver sends over the RF contains extra header bytes not counted in the RF Packet Size. Therefore, it is much more efficient to send a few large packets than to send many short packets. The maximum RF Packet Size is 239 bytes, or 0xEF, at 500kbps RF Data Rate and 96 bytes, or 0x60, at 280kbps RF Data Rate.

The RF Packet Size in Address 0x5A will not be used if Auto Config (Address 0x56, bit 0) is enabled. The default for the RF Data Rate will be used instead. The RF Packet Size should not be set to less than 0x07, to ensure AT commands can still be issued.

RF Packet Size is also used by the radio to determine the number of data slots per hop. In order to efficiently transmit data across the RF the radio will automatically add more data slots to the hop to correspond to a smaller RF Packet size. The number of slots per hop is given in the table below.

RF Data Rate	RF Packet Size	Number of Data Slots
280kbps	0x01 – 0x09	4 slots
280kbps	0x0A – 0x25	3 slots
280kbps	0x26-0x60	2 slots
500kbps	0x01 – 0x0C	6 slots
500kbps	0x0D – 0x25	5 slots
500kbps	0x026 – 0x47	4 slots
500kbps	0x48 – 0x7D	3 slots
500kbps	0x7E – 0xEF	2 slots

ENGINEER'S TIP

- The more slots per hop, the less likely that retries will occur on a new frequency, this may reduce the effectiveness of the module as a Frequency Hopping radio.
- Idle current consumption will increase as more slots are added.
- You need to use the same number of slots for every radio on the network.
- Full duplex still only reserves the first slot for the Server. If there are 6 slots, the first slot is reserved for the Server to transmit and the remainder is shared by the Clients.

RS-485 Data Enable

The Timing of the DE-RE pin will vary depending on the Interface Baud Rate selected. Prior to firmware v2.2, these parameters are set automatically if Auto Config is enabled. If Auto Config is Disabled, these values must be set correctly, even if RS-485 Data Enable is not being used. In v2.2 and beyond these parameters are not controlled by Auto Config, but instead by Address 0x57, bit 5.

The values to set are: 485_Delay_H: Address 0x49

485_Delay_M: Address 0x4A

485_Delay_L: Address 0x4B

To set them, use the equation (round the result up):

Address 0x49 and 0x4A: $485H/M = 8.125MHz / (81 * Baud_Rate)$, quotient only

Address 0x4B: $485L = (8.125MHz / Baud_Rate) \text{ mod } 81$

So for 19,200 you should calculate 00 05 12

THEORY OF OPERATION

FLOW CONTROL

Although flow control is not required for transceiver operation, it is recommended to achieve optimum system performance and to avoid overrunning the LT2510's serial buffers. The LT2510 uses separate buffers for incoming and outgoing data.

RXD Data Buffer And CTS

As data is sent from the OEM Host to the radio over the serial interface, it is stored in the LT2510's buffer until the radio is ready to transmit the data packet. The radio waits to transmit the data until one of the following conditions occur (whichever occurs first):

- The RF packet size is reached (EEPROM address 0x5A)
- An Interface Timeout occurs (EEPROM address 0x58)

The data continues to be stored in the buffer until the radio receives an RF Acknowledgement (ACK) from the receiving radio (addressed mode), or all transmit retries/broadcast attempts have been utilized. Once an ACK has been received or all retries/attempts have been exhausted, the current data packet is removed from the buffer and the radio will begin processing the next data packet in the buffer.

To prevent the radio's RXD buffer from being overrun, it is strongly recommended that the OEM Host monitor the radio's CTS output. When the number of bytes in the RXD buffer reaches the value specified by CTS_ON (EEPROM address 0x5C - 0x5D), the radio de-asserts (High) CTS to signal to the OEM Host to stop sending data over the serial interface. CTS is re-asserted after the number of bytes in the RXD buffer is reduced to the value specified by CTS_OFF (EEPROM addresses 0x5E- 0x5F); signalling to the OEM Host that it may resume sending data to the transceiver.

Note: It is recommended that the OEM Host cease all data transmission to the radio while CTS is de-asserted (High); otherwise potential data loss may occur.

TXD Data Buffer And RTS

As data to be forwarded to the OEM Host accumulates, it is stored in the LT2510's outgoing buffer until the radio is ready to begin sending the data to the OEM Host. Once the data packet has been sent to the Host over the serial interface, it will be removed from the buffer and the radio will begin processing the next data packet in the buffer. With RTS Mode disabled, the transceiver will send any data to the OEM Host as soon as it has data to send. However, some OEM Hosts are not able to accept data from the transceiver all of the time. With RTS Mode Enabled, the OEM Host can prevent the transceiver from sending it data by de-asserting RTS (High), causing the transceiver to store the data in its buffer. Upon asserting RTS up to two additional bytes can be received over the serial interface before the flow is stopped. Once RTS is re-asserted (Low), the transceiver will continue sending data to the OEM Host, beginning with any data stored in its buffer.

Note: Leaving RTS de-asserted for too long can cause data loss once the radio's TXD buffer reaches capacity.

ENGINEER'S TIP

Can I implement a design using just TXD, RXD and Gnd (Three-wire Interface)?

Yes. However, it is strongly recommended that your hardware monitor the CTS pin of the radio. CTS is taken High by the radio when its interface buffer is getting full. Your hardware should stop sending at this point to avoid a buffer overrun (and subsequent loss of data). You can perform a successful design without monitoring CTS. However, you need to take into account the amount of latency the radio adds to the system, any additional latency caused by retries, how often you send data, non-delivery network timeouts and interface data rate. Laird Technologies can assist in determining whether CTS is required for your application.

RADIO CONFIGURATIONS

Auto Channel (EEPROM 0x56, bit 3)

To allow for more flexible network configurations, Auto Channel can be enabled in clients to allow them to automatically synchronize with the first server they detect, regardless of channel number.

Note: A client with Auto Channel will only synchronize with a server having a matching System ID

Auto Config (EEPROM 0x56 bit 0)

The optimal settings for Interface Timeout and RF Packet Size vary according to the selected RF Profile and Interface Baud Rate. Enabling Auto Config will bypass the value for these variables stored in EEPROM and use predetermined values that have been optimized for the given mode. **When Auto Config is disabled, these values must be programmed in the transceiver EEPROM.**

THEORY OF OPERATION

Auto Destination (EEPROM 0x56, bit 4)

To simplify EEPROM programming, Auto Destination can be enabled in the radio which allows the radio to automatically set its destination to the address of the radio from which it last received a successful transmission from (beacon or data packet).

Auto Destination on Beacons Only (Address 0x56, bit 7)

When Auto Destination is enabled, the Client radio will address itself to the source of any received packet, including beacons from the server and any addressed or broadcast packets it receives. For point to multipoint networks where the Client is intended to only communicate back to the Server, this could cause the Client to inadvertently become addressed to another Client. By enabling Auto Destination on Beacons Only, the Client will only address itself upon reception of Beacons, therefore it will only address itself to the Server. Auto Destination on Beacons Only is only functional when Auto Destination is also enabled.

Auto System ID (EEPROM 45, bit 4)

When enabled this will allow a client to attach to any server on the same RF Channel, regardless of the System ID on the server or the client.

Beacon Skip (EEPROM 0x6F)

When set, the transceiver will send (Server) or listen (Client) for a beacon on hops spaced by the Beacon Skip number. On a Client, once the Beacon Skip count is reached the Client will listen every hop until it successfully hears a beacon. It will then wait a number of hops specified by the Beacon Refresh before listening again.

Enabling this will allow the transceiver to conserve power by disabling its RF circuitry during the beacon time. Enabling this on the Server will cause substantially longer sync times on the Clients.

Broadcast (EEPROM 0xC1, bit 7)

In Broadcast mode, the transceiver will transmit the packet to all transceivers with the same Channel Number and System ID settings. There is no RF acknowledgement sent from the recipient(s) back to the transmitter, therefore the packet is sent out the number of times specified by Broadcast Attempts.

Broadcast Attempts (EEPROM 0x4D)

When transmitting broadcast packets, the RF packet is broadcast out to all eligible receivers on the network. Broadcast Attempts is used to increase the odds of successful delivery to the intended receivers. Transparent to the OEM host, the transmitter will send the RF packet to the receivers. If a receiver detects a packet error, it will throw out the packet. This will continue until the transmitter exhausts all of its attempts. Once the receiver successfully receives the packet it will send the packet to the OEM host. It will throw out any duplicates caused by further Broadcast Attempts. The received packet will only be sent to the OEM host if it is received free of errors. Because broadcast packets have no RF acknowledgement, each packet is transmitted the number of times specified by Broadcast Attempts. This makes for very inefficient use of the available bandwidth; therefore, it is recommended that Broadcast Attempts be set as Low as possible and that broadcast packets be limited in use.

Note: Setting to 0 is equal to 256.

Destination Address (EEPROM 0x70-0x75)

The Destination Address is simply the MAC (IEEE) address of the intended receiver on the network. In Addressed Mode, the RF packet is sent out to the intended receiver designated by the Destination Address. Only the four LSBs (Least Significant Bytes) of the Destination Address are actually used for packet delivery. This field is ignored if Broadcast Mode, Auto Destination or Transmit API is enabled.

Disable Status Bin (EEPROM 0xC1, bit 4)

When set, disables the reception on the status slot of the bin. The result is that the Bin Analyzer and Remote I/O functionality will be disabled on the radio with the benefit of saving approximately 1mA average current consumption.

Discard Framing Error Packets (EEPROM 0x57, bit 7)

When set, the radio checks for a framing error in the UART buffer before processing incoming data. If an error is detected on any of the bytes in the buffer, the entire buffer is discarded.

THEORY OF OPERATION

Full Duplex (EEPROM 0x56, bit 1)

In Half Duplex mode, the transceiver will send a packet out over the RF immediately. This can cause packets sent at the same time by a server and a client to collide with each other over the RF. To prevent this, Full Duplex Mode can be enabled. This mode reserves a transmit “slot” for the server. If the server does not have any data to transmit, clients are permitted to transmit during that time. If the server does have data to send, clients will not be permitted to transmit during that slot. Likewise, the server will not be able to transmit during a client slot. Though the RF hardware is still technically half duplex, it makes the transceiver seem full duplex. This can cause overall throughputs to be cut in half.

Note: All transceivers on the same network must have the same setting for Full Duplex.

Hop Packet Delineation (EEPROM 0x57, bit6)

When enabled, in addition to using RF Packet Size and Interface Timeout as criteria for processing incoming data, the radio will also delineate packets up to once per hop once a minimum of six characters has been received over the serial port.

Legacy RSSI (EEPROM 0x45, bit 2)

RSSI (Received Signal Strength Indicator) is a measure of how well the receiving radio is able to hear the transmitting radio. By default, RSSI is reported in 2's complement format, therefore, values range from 0x80 - 0x7F. Many preceding products have, instead, reported RSSI in the range of 0x00 - 0xFF. Legacy RSSI causes 0x80 to be added to the RSSI result prior to reporting it to the host.

Max Power (EEPROM 0x63)

The transceiver has an adjustable RF output power. Power can be adjusted dynamically to optimize communications reliability and conserve power. Each increment represents a 3dBm 50% decrease in power. The radios have a maximum input RF level of 0dBm. When operated very close together at full power the radio's receiver can saturate and no transmissions are possible. If the distance between the transmitter and receiver is very short (generally less than 2ft (.6m) with 2.5dBi antennas), the Max Power should be reduced.

Mode (Server/Client) (EEPROM 0x41)

The server controls the frequency hop timing by sending out regular beacons (transparent to the transceiver host) which contain system timing information. This timing information synchronizes the client radio frequency hopping to the server. Each network should consist of only one server.

Nine Bit Mode (EEPROM 0x57, bit 1)

With Nine Bit mode disabled, the transceiver communicates over the asynchronous serial interface in 8-N-1 format (8 data bits, No parity, 1 stop bit). Some systems require a parity or 9th data bit. Enabling Nine Bit Mode causes the transceiver to communicate using 8-1-1 format (8 data bits, 1 parity bit and 1 stop bit). In this mode, the transceiver will not validate the parity bit but simply transmits it over the RF. This is useful as some systems use the ninth bit as an extra data bit and not just a parity bit. However, because the ninth bit is transmitted over the RF, enabling Nine Bit Mode cuts the transceiver interface buffer size by 1/9 and reduces the RF bandwidth by the same ratio.

Random Backoff (EEPROM 0xC3)

The transceivers utilize a Carrier Sense Multiple Access (CSMA) protocol with Random Backoff and a programmable back-off seed. Therefore, in the event of a collision, the transceiver will back off and retry the packet. Specifically, when two transceivers collide with each other (transmitting packets at the same time), each transceiver will choose a random number of packet times that it will wait before retrying the packet. Ideally, they will each choose a different number and will be successful in the next transmission. A good rule of thumb is to set Random Backoff to a number slightly larger than the maximum number of transceivers that would be expected to be transmitting at the same time.

Range Refresh (EEPROM 0x3D)

Range refresh specifies the maximum amount of time a transceiver will report In Range without having heard a server's beacon. It is adjustable in hop periods. Do not set to 0.

THEORY OF OPERATION

Remote I/O Mode (Address 0x57, bit 3)

Remote I/O Mode allows GPIOs on two radios to be joined together so their states will be reflected on the other radio. Enabling Remote I/O Mode will allow the local radio to transmit its GPIO states whenever there is a change. The states will be transmitted to the radio specified by the Destination Address (or as a Broadcast if Broadcast mode is enabled). State information will only be transmitted when there is a change on one of the enabled Digital Inputs. The states will be retransmitted up to the number of specified Utility Retries (Address 0x4E). Any changes to the Digital Inputs that occur while a Utility retransmission is occurring will not be transmitted unless the change persists until all Utility retries have been sent or an acknowledge was received. Therefore, this feature should only be used for slow-moving changes that occur less than the time it takes to expend all retries. Remote I/O is disabled when the Force 9600 pin is set at boot.

Remote I/O control lines occur in pairs, with the Digital Input on the local radio driving a Digital Output on the remote radio and vice-versa. This makes Remote I/O useful for both point to point and point to multipoint networks. Multipoint to point networks will not benefit from using a single pair of lines as the central point won't be able to tell where the line change was sourced. Multiple control lines are available though, so up to four pairs of lines can be used simultaneously. Likewise, analog inputs can be used (Address 0x57, bit 4) as the input (with a PWM output on the remote radio), though analog states will only be transmitted when a Utility packet is sent, which are only triggered by the change of a Digital Input. Threshold settings are not available on analog Inputs.

Output lines will be initialized at boot according to Remote I/O Status (Address 0xC9-0xCA) for the Digital lines and PWM_Init (Address 0xC8) for the PWM output.

Which control lines are used in Remote I/O is set by the Remote I/O Control bit field (Address 0x60). Note, TxD/RxD is one pair of Remote I/O lines available. If this pair is used, the module will not respond to Commands and will not be able to transmit or receive serial data. If this pair is enabled, Force 9600 must be Low at boot to disable Remote I/O if serial communications are desired.

Address 0x60, Bit	Input	Output
Bit 0 set	GIO_4	GIO_0
Bit 1 set	GIO_8*	GIO_1
Bit 2 set	GIO_7	GIO_3
Bit 3 set	CMD/Data	GIO_2
Bit 4 set	RTS	CTS
Bit 5 set	RXD	TXD
Bit 6 clear, Bit 7 clear	All I/O are Outputs	
Bit 6 set, Bit 7 clear	All I/O are Inputs	
Bit 7 set	Inputs and Outputs are as specified in table	

*GIO_8 (Pin 18) on board revisions 0050-00203 Rev 0 and 0050-00196 rev 2 (and below) is internally not connected. This pin is unavailable as a GPIO on these boards.

ENGINEER'S TIP

- When using GIO_7/GIO_3 Pairs, the input/output will be digital unless Remote Analog Enable bit is set (Address 0x57, bit 4) in which case the input is Analog and the output is PWM.
- TXD and RXD are not available for UART serial data when used as in Remote I/O. Force 9600 must be Low on boot to disable Remote I/O Mode and issue commands.
- When not using pairs (bit 7 clear), one radio should have all I/O as inputs and the other radio or radios should have all I/O as output.
- Remote I/O Mode must be enabled on both the local and remote radio and the Remote I/O Control Bit must be set for the same pair on both radios.
- All I/O state information for all lines is transmitted when any update is triggered. Thus, on the receiving radio any enabled output pins will be updated, regardless of whether those pins were enabled on the transmitting radio.

RF Channel Number (EEPROM 0x40)

This product uses FHSS (Frequency Hopping Spread Spectrum) protocol in which the transceiver will communicate using frequency "bins" spaced throughout the frequency band. Therefore, RF Channel Number specifies a unique pseudo-random hopping sequence.

THEORY OF OPERATION

RF Profile (EEPROM 0x54)

RF Profile can be adjusted to provide a trade-off between throughput and range. Deciding which RF Profile to choose depends on the individual application. Selecting a higher RF baud rate will provide increased RF bandwidth. However, selecting the lower RF baud rate will provide significantly improved range. Selecting fewer hops provides a shorter sync time, whereas more hops will provide better interference and collocated system immunity.

RSSI

Received Signal Strength Indicator (RSSI) is available to the OEM through a number of means. AT Commands such as Bin Analyzer and Report RSSI will report RSSI, API Packets for Received and Send Data Complete will report RSSI and one of three pins can be configured to provide a PWM output representing the RSSI. By default, all of these commands, except PWM Output represent RSSI as that is a hexadecimal 2's complement form. Legacy RSSI (detailed above) can be enabled to provide the RSSI in a non 2's complement form from 0x00 (very weak signal) to 0xFF (very strong signal). The control commands for PWM output utilize a Legacy RSSI format from 0x00 to 0xFF.

The RSSI values reported can be converted to a decibel value with the following formulas:

For Non-Legacy values where the RSSI in Hexadecimal ranges from 0x80 to 0x7F:

If this value is greater than or equal to 128, then:

$$\text{RSSI_dBm} = (\text{RSSI_Dec} - 256)/2 - \text{RSSI_Offset}$$

If this value is less than 128, then:

$$\text{RSSI_dBm} = (\text{RSSI_Dec})/2 - \text{RSSI_Offset Where,}$$

For Legacy RSSI the equation is:

$$\text{RSSI_dBm} = (\text{RSSI_Dec} - 128)/2 - \text{RSSI_Offset}$$

RSSI_Dec is the reported value represented in Decimal notation

RSSI_Offset = 82

Reported RSSI values are meant as estimate and have an accuracy of +/- 2dBm. The RSSI reported by various commands has an effective range of -25dBm to -95dBm, outside of this range, the accuracy is not maintained.

RSSI_Control (EEPROM 0x68):

RSSI Control is a bitfield used to control the output of the RSSI PWM output and what messages the radio reports on. Note if Disable Hop Frame is Disabled (so as to report Hop Frame), it will be output on GO_0 (pin 1 of SMT module), so the PWM Output should not be set to output to that pin or conflicting signals will be sent on that output pin.

Address 0x68, Bit	Input	Output
Bit 0 set	GIO_4	GIO_0
Bit 1 set	GIO_8*	GIO_1
Bit 2 set	GIO_7	GIO_3
Bit 3 set	CMD/Data	GIO_2
Bit 4 set	RTS	CTS
Bit 5 set	RXD	TXD
Bit 6 clear, Bit 7 clear	All I/O are Outputs	
Bit 6 set, Bit 7 clear	All I/O are Inputs	

RSSI_Lag (EEPROM 0x67)

Controls a filter on the PWM output to smooth out the changes made to the PWM signal. Setting the value to a very Low number will result in very quick changing output. Setting the value to a higher number will result in a slower varying PWM output. Setting the value to 0x00 will result in an instantaneous RSSI. Because RSSI is measured per hop and the radio can hop over 43 or 79 hops, instantaneous RSSI may be too quickly moving to be of use as a signal strength indicator. The default value is 0x40 and should be sufficient for most applications. It should be set to a value of less than 0x80.

RSSI_Lag affects the PWM Output according to the following equations:

$$\text{Cumulative_Lag} = \text{Cumulative_Lag} + (\text{RSSI_Current} - \text{Old_RSSI_Avg})$$

$$\text{New_RSSI_Avg} = \text{Old_RSSI_Avg} + (\text{Cumulative_Lag} \text{ mod } \text{EE_Lag})$$

Cumulative_Lag is then stored in memory until the next time RSSI is calculated.

If $(\text{Cumulative_Lag} \text{ mod } \text{EE_Lag}) > 0$, then $\text{Cumulative_Lag} = \text{remainder of } (\text{Cumulative_Lag} \text{ mod } \text{EE_Lag})$

THEORY OF OPERATION

RSSI Output to PWM

A moving RSSI Average can be written to the PWM Output as a signal strength indicator. The output pin to use, the threshold range for the RSSI and the RSSI Type reported can all be configured through EEPROM Addresses.

The PWM Output has a 315.077µs period. The duty cycle is set by the RSSI value recorded by the transceiver and the RSSI Threshold High and RSSI Threshold Low values

RSSI Threshold High (EEPROM 0x65)

Is the upper limit of the recorded RSSI reading. RSSI Values reported above this value (strong signals) will report a 100% Duty Cycle on the PWM Output.

RSSI Threshold Low (EEPROM 0x66)

Is the lower limit of the recorded RSSI reading. RSSI Values reported below this value (weak signals) will report a 0% Duty Cycle on the PWM Output.

To calculate the thresholds use the equation:

$$\text{RSSI_Dec} = (\text{RSSI_dBm} + 82) * 2 + 128$$

Then convert this from Decimal to Hexadecimal notation.

Sleep Indicator (EEPROM 0x45, bit 6)

When enabled, GIO_1 will toggle Low during sleep and high when the module is awake.

Sniff Permit (EEPROM 0x45, bit 0)

Sniff Permit will allow a radio to receive a data packet from another radio on the network regardless of the Destination MAC Address in the packet. This allows an OEM to create a Sniffer for all network traffic. Sniff Permit would need to be enabled on the transmitting radio, to grant it's permission to be heard. Sniff Report and Sniff Permit would need to be enabled on the sniffer radio, to cause it to send sniffed packets out the serial port.

System ID (EEPROM 0x76)

System ID is similar to a password character or network number and makes network eavesdropping more difficult. A receiving transceiver will not go in range of or communicate with another transceiver on a different System ID. System ID can be ignored on a Client by enabling Auto System ID

Transmit Retries (EEPROM 0x4C)

When transmitting addressed packets, the RF packet is sent out to the receiver designated by its destination address. Transmit Retries is used to increase the odds of successful delivery to the intended receiver. Transparent to the OEM host, the transmitter will send the RF packet to the intended receiver. If the receiver receives the packet free of errors, it will send the transmitter an acknowledgement. If the transmitter does not receive this acknowledgement, it will assume the packet was never received and retry the packet. This will continue until the packet is successfully received or the transmitter exhausts all of its retries. The received packet will only be sent to the OEM host if and when it is received free of errors.

Note: Setting to 0 is equal to 256.

Unicast Only (EEPROM 0xC1, bit 3)

To prohibit transceivers from receiving broadcast packets, Unicast Only can be enabled. Unicast Only restricts the transceiver to only receive addressed packets.

Vendor ID

The Vendor ID, like the System ID, can be used to uniquely identify a network. Radios with the Vendor ID set, will only communicate with other radios with the same set Vendor ID.

The Vendor ID is a protected EEPROM parameter and it's value cannot be read. It can only be written once. OEMs should be aware that improperly setting the Vendor ID can cause communication issues. Setting the Vendor ID to an unknown setting will effectively render the radio unable to communicate in a network.

Note: The Vendor ID is a one-time write parameter and it cannot be read.

9600 Boot Option (EEPROM 0x57, bit 0)

When enabled, 9600 Boot Option causes the 9600 pin to be ignored on cold boot (power-up) and brown-out conditions. Therefore, the 9600 pin is only observed on warm boots (reset pin toggled). This can be helpful so that brown-out conditions don't cause the baud rate to change if the 9600 pin happens to be Low at the time. When 9600 Boot Option is disabled, the 9600 pin will be used for warm and cold boots as well as brown-out conditions.

**EEPROM
PARAMETERS**

The LT2510 utilizes a server-client network architecture to synchronize the frequency hopping. Each network must have one radio configured as a Server and all other radios configured as Clients. When a radio is configured as a Server, it will transmit a beacon at the beginning of each hop. Radios configured as Clients will default to a receive mode where they are scanning the available frequencies listening for a beacon from a Server in their network. When a Client detects the Server's beacon, the client will synchronize to it and transition the InRange pin Low. When the Server and the Client are synchronized they can begin transferring data.

TABLE 9: EEPROM PARAMETERS

PARAMETERS	EEPROM ADDRESS	LENGTH (BYTES)	RANGE	DEFAULT	DESCRIPTION
Product ID	0x00	0x23			Product identifier string. Includes revision information for software and hardware.
Range Refresh	0x3D	1	0x01-0xFF	0x48	Specifies the maximum amount of time a transceiver will report In Range without having heard a Server's beacon. Equal to hop period * value, do not set to 0x00.
Channel Number	0x40	1	79 Hops: 0x00 – 0x4E, 43 Hops: 0x00 – 0x2A	0x00	Selects a unique hopping sequence in order to demarcate collocated networks.
Mode: Server/Client	0x41	1	0x01: Server 0x02: Client	0x02	Sets the mode type. Each network has one and only one Server and any number of Clients. The Server is responsible for transmitting beacons, which are used by the Clients to locate and synchronize their hopping to that of the Server.
Baud Rate	0x42	1	0x00-0x0A, 0xE3	0x09	Baud Rate, see serial interface section for details. Default represents 115,200kbps. Setting this address to 0xE3 will allow the user to set a custom baud rate with the Baud_M and Baud_E registers.
Baud_M	0x43	1	0x00-0xFF	0x00	Baud_M is used for setting custom baud rate, see Serial Interface Baud Rate section for more details
Baud_E	0x44	1	0x00-0xFF	0x02	Baud_E is used for setting custom baud rate, see Serial Interface Baud Rate section for more details
Control 0	0x45	1	Bit Adjustable	0x88	Settings are: bit-7: Reserved. Do not modify bit-6: Sleep Indicator: GIO_1 0 = Disable Sleep Indicator 1 = Enable Sleep Indicator bit-5: Reserved. Do not modify bit-4: Auto System ID 0 = Disable Auto System ID 1 = Enable Auto System ID bit-3: Command/Data Receive Disable 0 = Disable CMD/Data RX Disable 1 = Enable CMD/Data RX Disable (radio will accumulate received RF packets until the CMD/Data pin goes High, at which time it will forward all stored packets to its host). bit-2: Legacy RSSI 0 = Disable Legacy RSSI 1 = Enable Legacy RSSI bit-1: Sniff Report 0 = Discard sniffed packets 1 = Report sniffed packets bit-0: Sniff Permit 0 = Disable Sniff Permit 1 = Enable Sniff Permit
Transmit Retries	0x4C	1	0x01-0xFF	0x03	Maximum number of times a packet is retransmitted when Addressed packets are being sent. Note: A setting of 0x00 will select 256 retries.

**EEPROM
PARAMETERS**

TABLE 9: EEPROM PARAMETERS (CONTINUED)

PARAMETERS	EEPROM ADDRESS	LENGTH (BYTES)	RANGE	DEFAULT	DESCRIPTION																
Broadcast Attempts	0x4D	1	0x01-0xFF	0x03	Number of times each packet is transmitted when Broadcast packets are being sent. <i>Note:</i> A setting of 0x00 will select 256 attempts.																
Utility Retries	0x4E	1	0x00-0xFF	0x03	Used by Remote I/O mode to increase the odds of delivery of a Remote I/O line update. Sets the number of retries or attempts used to transmit a Remote I/O line status change.																
RF Profile	0x54	1	* See Description		<table border="1"> <thead> <tr> <th>RF Profile</th> <th>RF Data Rate</th> <th>Number of Hops</th> <th>Details</th> </tr> </thead> <tbody> <tr> <td>0x00</td> <td>500Kbps</td> <td>43</td> <td>Valid for international use. Can be selected on any PRM1xx product.</td> </tr> <tr> <td>0x01</td> <td>280Kbps</td> <td>79</td> <td>For FCC Markets only This is the default setting for PRM110/111/120/121</td> </tr> <tr> <td>0x03</td> <td>280Kbps</td> <td>43</td> <td>This is the default setting for PRM112/113/122/123</td> </tr> </tbody> </table> <p>Superseded RF Data Rate (Addresses 0x51-0x53) in FW v1.3 and beyond.</p>	RF Profile	RF Data Rate	Number of Hops	Details	0x00	500Kbps	43	Valid for international use. Can be selected on any PRM1xx product.	0x01	280Kbps	79	For FCC Markets only This is the default setting for PRM110/111/120/121	0x03	280Kbps	43	This is the default setting for PRM112/113/122/123
RF Profile	RF Data Rate	Number of Hops	Details																		
0x00	500Kbps	43	Valid for international use. Can be selected on any PRM1xx product.																		
0x01	280Kbps	79	For FCC Markets only This is the default setting for PRM110/111/120/121																		
0x03	280Kbps	43	This is the default setting for PRM112/113/122/123																		
Control 1	0x56	1	0x01-0xFF	0x61	<p>Settings are:</p> <ul style="list-style-type: none"> bit-7: Auto Destination on Beacons only (only functional when Auto Destination is also enabled) <ul style="list-style-type: none"> 0 = Disable - Radio will set destination based on any received packet 1 = Enable - Radio will set destination based only on the beacon from the Server bit-6: Disable Hop Frame <ul style="list-style-type: none"> 0 = Disable (Turns on Hop Frame Pin) 1 = Enable (Turns off Hop Frame Pin) bit-5: Reserved bit-4: Auto Destination <ul style="list-style-type: none"> 0 = Use Destination Address 1 = Use Auto Destination bit-3: Client Auto Channel <ul style="list-style-type: none"> 0 = Disable Auto Channel 1 = Enable Auto Channel bit-2: RTS <ul style="list-style-type: none"> 0 = Disable RTS handshaking 1 = Enable RTS handshaking bit-1: Duplex <ul style="list-style-type: none"> 0 = Half Duplex 1 = Full Duplex bit-0: Auto Config <ul style="list-style-type: none"> 0 = Auto Config Disabled 1 = Auto Config Enabled 																

**EEPROM
PARAMETERS**

TABLE 9: EEPROM PARAMETERS (CONTINUED)

PARAMETERS	EEPROM ADDRESS	LENGTH (BYTES)	RANGE	DEFAULT	DESCRIPTION
Control 2	0x57	1	0x00-0xFF	0x01	<p>Settings are: bit-7: Discard Framing Errors 0 = Framing error register is ignored 1 = Upon detecting a framing error, the entire packet is discarded</p> <p>bit-6: Hop Packet Delineation 0 = Disabled 1 = UART data will be transmitted once per hop as soon as a minimum of six bytes have been accumulated, regardless of whether Interface Timeout or RF Packet Size has been reached.</p> <p>bit-5: Override 485 timing 0 = 485 DE-RE timing is set by the radio automatically 1 = 485 DE-RE timing is set by value in EEPROM</p> <p>bit-4: Remote Analog Enable 0 = Disable Remote Analog 1 = Enable Remote Analog</p> <p>bit-3: Remote I/O Mode 0 = Disable Remote I/O Mode 1 = Enable Remote I/O Mode</p> <p>bit-2: RS-485 Data Enable 0 = Disable RS-485 Data Enable 1 = Enable RS-485 Data Enable</p> <p>bit-1: Nine Bit Mode 0 = Disable Nine Bit Mode 1 = Enable Nine Bit Mode</p> <p>bit-0: 9600 Boot Option 0 = Disable 9600 Boot Option 1 = Enable 9600 Boot Option</p>
Interface Timeout	0x58	1	0x02-0xFF	0x03	Specifies a byte gap timeout, used in conjunction with RF Packet Size to determine when a packet coming over the interface is complete (200us per increment). This is only used when Auto Config is disabled.
RF Packet Size	0x5A	1	*See Description	0x60	<p>Used in conjunction with Interface Timeout; specifies the maximum size of an RF packet. Value in address is only used when Auto Config is disabled.</p> <p>RF Packet Size should not be less than 0x06 to ensure AT Commands can be issued. The maximum value is 0x60 for 280kbps RF Data Rate and 0xEF for 500kbps RF Data Rate. Note: Must be set to a minimum of 6 in order to send the Enter AT command.</p>
CTS On	0x5C	2	0x0000 - 0x1FFF	0x01C0	<p>If the transceiver buffer fills up and more bytes are sent to it before the buffer can be emptied, data loss will occur. The transceiver prevents this loss by deasserting CTS High as the buffer fills up and asserting CTS Low as the buffer is emptied. CTS should be monitored by the Host device and data flow to the radio should be stopped when CTS is High.</p> <p>CTS will be deasserted (High) when the transmit buffer contains this many characters or more.</p>

**EEPROM
PARAMETERS**

TABLE 9: EEPROM PARAMETERS (CONTINUED)

PARAMETERS	EEPROM ADDRESS	LENGTH (BYTES)	RANGE	DEFAULT	DESCRIPTION
CTS Off	0x5E	2	0x0000 - 0x01FE	0x0180	<p>If the transceiver buffer fills up and more bytes are sent to it before the buffer can be emptied, data loss will occur. The transceiver prevents this loss by deasserting CTS High as the buffer fills up and asserting CTS Low as the buffer is emptied. CTS should be monitored by the Host device and data flow to the radio should be stopped when CTS is High.</p> <p>Once the CTS has been deasserted, CTS will be reasserted (Low) when the transmit buffer contains this many or less characters.</p>
Remote I/O Control	0x60	1	0x00-0xFF	0x00	<p>Settings are: bit-7: Use Pairs 0 = Disable pairs and allows radio I/O already set in bits 5-0 to be all input or all output 1 = Enable pairs with bits 5-0 set bit-6: All Inputs 0 = All configured I/O are output (if Bit 7 is clear) 1 = All configured I/O are inputs (if Bit 7 is clear) bit-5: Enable RXD/TXD Pair 0 = Disable RXD/TXD Pair for Remote I/O Mode 1 = Enable RXD/TXD Pair for Remote I/O Mode (disables serial data) bit-4: Enable RTS/CTS Pair 0 = Disable RTS/CTS Pair for Remote I/O Mode 1 = Enable RTS/CTS Pair for Remote I/O Mode (disables RTS) bit-3: Enable CMD/Data –GIO_2 Pair 0 = Disable CMD/Data –GIO_2 Pair for Remote I/O Mode 1 = Enable CMD/Data –GIO_2 Pair for Remote I/O Mode (May affect DE-RE) bit-2: Enable GIO_7/GIO_3 Pair 0 = Disable GIO_7/GIO_3 Pair for Remote I/O Mode 1 = Enable GIO_7/GIO_3 Pair for Remote I/O Mode (I/O Type depends on Remote Analog Enable) bit-1: Enable GIO_8/GIO_1 Pair* 0 = Disable GIO_8/GIO_1 Pair for Remote I/O Mode bit-0: Enable GIO_4/GIO_0 Pair 0 = Disable GIO_4/GIO_0 Pair for Remote I/O Mode 1 = Enable GIO_4/GIO_0 Pair for Remote I/O Mode (may affect Hop Frame output)</p> <p>*Pin 18 (GIO_8) on board revisions 0050-00203 Rev 0 and 0050-00196 rev 2 (and below) is internally not connected. This pin is unavailable as a GPIO on these boards.</p>

**EEPROM
PARAMETERS**

TABLE 9: EEPROM PARAMETERS (CONTINUED)

PARAMETERS	EEPROM ADDRESS	LENGTH (BYTES)	RANGE	DEFAULT	DESCRIPTION
Max Power	0x63	1	0x00-0x03	0x00	Used to increase/decrease the output power: PRM110/111/120/121 PRM112/113/122/123 0x00: 21 dBm typical 0x00: 17dBm typical 0x01: 17 dBm typical 0x01: 14 dBm typical 0x02: 14 dBm typical 0x02: 11 dBm typical 0x03: 11 dBm typical 0x03: 8 dBm typical
RSSI Threshold High	0x65	1	0x00-0xFF	0xFF	Sets the High threshold for RSSI. If the RSSI is above RSSI Threshold High, then 0xFF (100% Duty Cycle) will be written to the PWM Output. *See RSSI Output on PWM for more details
RSSI Threshold Low	0x66	1	0x00-0xFF	0x50	Sets the Low threshold for RSSI. If the RSSI is below RSSI Threshold Low, then 0x00 (0% Duty Cycle) will be written to the PWM Output *See RSSI Output on PWM for more details
RSSI Lag	0x67	1	0x00-0xFF	0x40	Constant controlling the rate of change of the PWM Output
RSSI Control	0x68	1	0x00-0xFF	0xF1	Settings are:

Note: The transceivers are shipped at maximum allowable power.

bit-7: PWM Output Port*
bit-6: PWM Output Port*
bit-5: Use Average RSSI
0 = Ignore RSSI_Lag and report instantaneous RSSI
1 = Uses RSSI_Lag and reports moving average of RSSI
bit-4: Invert Report
0 = PWM Outputs higher duty cycle for a stronger signal
1 = PWM Outputs lower duty cycle for a stronger signal
bit-3: Unintended Report
0 = Disable Unintended report
1 = Reports RSSI on packets not intended for this transceiver
bit-2: Broadcast Report
0 = Disable Broadcast Report
1 = Reports RSSI on Broadcast packets received
bit-1: Addressed Report
0 = Disables Addressed Report
1 = Reports RSSI on packets specifically addressed to this transceiver
bit-0: Beacon Report
0 = Disables Beacon Report
1 = Reports RSSI on the beacon from the Server

* PWM Output Port.
The OEM can control which ports are used for PWM Output according to the following table:

Bit 6	Bit 7	SMT Pin	Pluggable Pin
0	0	2	6
0	1	1	7
1	0	5	19
1	1	5	19

**EEPROM
PARAMETERS**

TABLE 9: EEPROM PARAMETERS (CONTINUED)

PARAMETERS	EEPROM ADDRESS	LENGTH (BYTES)	RANGE	DEFAULT	DESCRIPTION
Beacon Skip	0x6F	1	0x00-0xFF	0x00	When set, the transceiver will send (Server) or listen (Client) for a beacon on hops spaced by the Beacon Skip number. On a Client, once the Beacon Skip count is reached the Client will listen every hop until it successfully hears a beacon. It will then wait a number of hops specified by the Beacon Skip before listening again. Enabling this will allow the transceiver to conserve power by disabling its RF circuitry during the beacon time. Enabling this on the Server will cause substantially longer sync times on the Clients.
Destination MAC Address	0x70	6	0x00-0xFF		Specifies destination for RF packets. Only the last four LSBs are used for RF Communication.
System ID	0x76	1	0x00-0xFF	0x01	Similar to network password. Radios must have the same System ID to communicate with each other.
MAC Address	0x80	6			Factory set unique MAC Address of radio. Only the last four LSBs are used for RF Communication.
Part Numbers	0x90	16			Factory set part number for the unit
User Memory	0xA0	16	0x00-0xFF	0xFF	This memory is reserved host memory and will never be used by the radio. The host is free to use this memory as desired and it will only be modified when instructed to do so by the host.
API Control	0xC1	1	0x01-0xFF	0x00	Settings are: bit-7: Broadcast Mode 0 = Disable 1 = Enable bit-6: Inrange High on Wake bit-5: Sleep Calibration Enable bit-4: Disable Status Bin 0 = Use Status Bin 1 = Ignore Status Bin bit-3: Unicast Only 0 = Disable 1 = Enable bit-2: Send Data Complete API 0 = Disable 1 = Enable bit-1: Transmit API 0 = Disable 1 = Enable bit-0: Receive API 0 = Disable 1 = Enable
Random Backoff	0xC3	1	0x00-0xFF	0x00	The transceivers utilize a Carrier Sense Multiple Access (CSMA) protocol with Random Backoff and a programmable back-off seed. Therefore, in the event of a collision, the transceiver will back off and retry the packet. Specifically, when two transceivers collide with each other (transmitting packets at the same time), each transceiver will choose a random number of packet times that it will wait before retrying the packet. Ideally, they will each choose a different number and will be successful in the next transmission. A good rule of thumb is to set Random Backoff to a number slightly larger than the maximum number of transceivers that would be expected to be transmitting at the same time. Settings: 1 packet time: 0x00 1-2 packet times: 0x01 1-4 packet times: 0x03 1-8 packet times: 0x0F 1-16 packet times: 0x0F 1-32 packet times: 0x1F 1-64 packet times: 0x3F 1-128 packet times: 0x7F 1-256 packet times: 0xFF

**EEPROM
PARAMETERS**

TABLE 9: EEPROM PARAMETERS (CONTINUED)

PARAMETERS	EEPROM ADDRESS	LENGTH (BYTES)	RANGE	DEFAULT	DESCRIPTION
PWM Initialize	0xC8	1	0x00-0xFF	0xFF	Initializes PWM Output (GIO_3) at boot to this value
Remote I/O Initialize High	0xC9	1	0x00-0xFF	0xFF	Settings are: bit-7: Reserved. Do not modify bit-6: Reserved. Do not modify bit 5: RXD Initialize 0 = RXD is initialized Low at boot 1 = RXD is initialized High at boot bit 4: RTS Initialize 0 = RTS is initialized Low at boot 1 = RTS is initialized High at boot bit 3: CMD/Data Initialize 0 = CMD/Data is initialized Low at boot 1 = CMD/Data is initialized High at boot bit 2: GIO_7 Initialize 0 = GIO_7 is initialized Low at boot 1 = GIO_7 is initialized High at boot bit 1: GIO_8 Initialize* 0 = GIO_8 is initialized Low at boot 1 = GIO_8 is initialized High at boot bit 0: GIO_4 Initialize 0 = GIO_4 is initialized Low at boot 1 = GIO_4 is initialized High at boot *Pin 18 (GIO_8) on board revisions 0050-00203 Rev 0 and 0050-00196 rev 2 (and below) is internally not connected. This pin is unavailable as a GPIO on these boards.
Remote I/O Initialize Low	0xCA	1	0x00-0xFF	0xFF	Settings are: bit-7: Reserved. Do not modify bit-6: Reserved. Do not modify bit 5: TXD Initialize 0 = TXD is initialized Low at boot 1 = TXD is initialized High at boot bit 4: CTS Initialize 0 = CTS is initialized Low at boot 1 = CTS is initialized High at boot bit 3: GIO_2 Initialize 0 = GIO_2 is initialized Low at boot 1 = GIO_2 is initialized High at boot bit 2: GIO_3 Initialize 0 = GIO_3 is initialized Low at boot 1 = GIO_3 is initialized High at boot bit 1: GIO_1 Initialize 0 = GIO_1 is initialized Low at boot 1 = GIO_1 is initialized High at boot bit 0: GIO_0 Initialize 0 = GIO_0 is initialized Low at boot 1 = GIO_0 is initialized High at boot
D.O.B.	0xE0	4			Provides factory calibration and test date.

CONFIGURING THE LT2510

The LT2510 can be configured using AT Configuration Commands. These commands can be issued only in Command Mode. Command Mode can be entered by setting the CMD/Data pin of a transceiver Low or by issuing the Enter AT Command.

AT COMMANDS

There are four types of configuration supported by the LT2510; On-the-Fly commands for dynamic reprogramming of running memory, EEPROM commands for making persistent changes to EEPROM, Utility commands for dealing with Command Mode and Status Commands for querying the radio for information. When in Command Mode, the RF is still active and incoming RF packets are queued in the radio until Command Mode has been exited. If in Command Mode via the CMD/Data pin and Command/Data RX Disable has been disabled, incoming RF packets will not be queued and will be sent to the host immediately.

AT Commands sent to the LT2510 must still adhere to the interface guidelines specified by the Interface Timeout and RF Packet Size. For this reason, standard terminal emulators, such as HyperTerminal, cannot be used to configure the LT2510. Manually typing AT Commands will cause the Interface Timeout to be reached between characters and the command will be discarded if already in Command Mode or transmitted if not. AT commands should be issued either with the Laird Technologies OEM Configuration Utility or sent directly from a microcontroller or other host. When an invalid command is sent, the radio discards the data and no response is sent to the OEM Host. Table 8 below shows a quick summary of the basic configuration and diagnostic commands available on the LT2510. For detailed command information, please refer to the command descriptions immediately following the Quick Reference Table.

On-The-Fly Control Commands

The LT2510 transceiver contains memory that holds many of the parameters that control the transceiver operation. Using the On-the-Fly command set allows many of these parameters to be viewed and changed during system operation. Because the memory these commands affect is dynamic, when the transceiver is reset, these parameters will revert back to the settings stored in the EEPROM.

EEPROM Configuration Commands

Two Commands are available to read and write the EEPROM of the radio. These commands are very powerful as they can control the entire configuration of the radio. They should be used with caution as overwriting reserved areas of memory can adversely affect the operation of the radio. The radio must be reset for any changes to the EEPROM to take affect.

Utility Commands

Utility Commands are used to enter and exit AT Command Mode and to reset the radio.

Status Commands

Status Commands are used to query the radio for information. Status commands can be used to poll GPIOs, ADCs or to retrieve information about the state of the network. Status commands do not affect the operation of the transceiver aside from being in Command Mode.

COMMAND QUICK REFERENCE

Table 8 provides an at-a-glance view of all available AT commands.

TABLE 8: COMMAND QUICK REFERENCE

COMMAND NAME	COMMAND (ALL BYTES IN HEX)	RETURN (ALL BYTES IN HEX)
UTILITY COMMANDS		
Enter AT Command Mode	<0x41> <0x54> <0x2B> <0x2B> <0x2B> <0x0D>	<0xCC> <0x43> <0x4F> <0x4D>
Exit AT Command Mode	<0xCC> <0x41> <0x54> <0x4F> <0x0D>	<0xCC> <0x44> <0x41> <0x54>
Enter Sleep	<0xCC> <0x86> <Mode> <Res> <Timer_H> <Timer_L>	None
Soft Reset	<0xCC> <0xFF>	None
Restore Factory Settings and Soft Reset	<0xCC> <0xFF> <0xDF>	None
STATUS COMMANDS		
Status Request	<0xCC> <0x00> <0x00>	<0xCC> <Firmware Version> <Status>
Check Status Registry	<0xCC> <0x00> <0x01>	<0xCC> <Response[32bits]>
Bin Analyzer	<0xCC> <0x8F> <Data> <Optional NumRuns>	<0xCC> <Data>
Read Temperature	<0xCC> <0xA4>	<0xCC> <Temperature>
ON-THE-FLY COMMANDS		
Change Channel	<0xCC> <0x02> <Channel>	<0xCC> <Channel>
Change Server/Client	<0xCC> <0x03> <Data>	<0xCC> <Firmware Version> <Status>
Set Broadcast Mode	<0xCC> <0x08> <Data>	<0xCC> <Data>
Read IRAM	<0xCC> <0x0A> <Location>	<0xCC> <Value>
Write IRAM	<0xCC> <0x0B> <Location> <Value>	<0xCC> <Location> <Value>
Write Destination Address	<0xCC> <0x10> <Dest Address last three bytes>	<0xCC> <Dest Address>
Read Destination Address	<0xCC> <0x11>	<0xCC> <Dest Address>
Auto Destination/Channel	<0xCC> <0x15> <Data>	<0xCC> <Data>
Read API Control	<0xCC> <0x16>	<0xCC> <API Control>
Write API Control	<0xCC> <0x17> <API Control>	<0xCC> <API Control>
Read Digital Input	<0xCC> <0x20>	<0xCC> <Data>
Read ADC	<0xCC> <0x21> <Data>	<0xCC> <ADC Hi> <ADC Lo>
Get Last RSSI	<0xCC> <0x22>	<0xCC> <RSSI>
Write Digital Outputs	<0xCC> <0x23> <Data>	<0xCC> <Data>
Write PWM	<0xCC> <0x24> <Data>	<0xCC> <Data>
Set Power Control	<0xCC> <0x25> <Power>	<0xCC> <Power>
EEPROM COMMANDS		
EEPROM Byte Read	<0xCC> <0xC0> <Start> <Length>	<0xCC> <Start> <Length> <Data [n-0]>
EEPROM Byte Write	<0xCC> <0xC1> <Start> <Length> <Data>	<Start> <Length> <Last Byte Written>
Write Flash	<0xCC><0xC4><Start_H><Start_L> <Length_H><Length_L><Data>	<0xCC><0xC4><Result> <Start_H><Start_L>
Decrypt New Image	<0xCC><0xC5>	<0xCC><0xC5><Data>
Erase Flash	<0xCC><0xC6>	<0xCC><0xC6>
Read Flash	<0xCC><0xC9><Start_H><Start_L> <Length_H><Length_L>	<0xCC><0xC9><Result><Start_H> <Start_L><Length_H> <Length_L><Data>
Set Vendor ID	<0xCC> <0xF2> <0x06> <Vid_H><Vid_L>	<0xCC> <0xF2> <0x06> <Data>

CONFIGURING THE LT2510

UTILITY COMMANDS

Enter AT Command Mode

Prior to sending this command, the OEM Host must ensure that the transceiver's serial RX buffer is empty. This can be accomplished by framing the command with rest periods equal to the Interface Timeout or greater (depending on radio configuration). If the buffer is not empty, the radio might concatenate the string to existing data in the buffer and it will be sent over the RF.

Exit AT Command Mode

The OEM Host should send this command to exit AT Command mode and resume normal operation.

Enter Deep Sleep

The OEM Host issues this command to put the module into a Sleep state to minimize current draw. While sleeping, the processor has all interfaces disabled (including RF and serial). Pin states are maintained while in sleep. A reset of the radio (soft or hard) cancels any current sleep mode. Two sleep modes are supported in the module: PM2 and PM3.

PM2: The module can either be awakened by the Sleep Interrupt pin (Force 9600) going Low or the sleep timer expiring. When a Server enters PM2, it stops sending beacons until it awakes. Upon awakening from PM2, a Client will calculate which frequency the Server should be located on (based on the duration of the sleep period) and will attempt to resync with the Server on that frequency. As such, a Client will not be permitted to transmit data, following PM2, until receiving a beacon from its Server. Enabling In Range High on Wake permits the host to monitor the In Range pin to determine when the Client has received a beacon from its Server.

PM3: The module can only be awakened by the Sleep Interrupt pin (Force 9600). The sleep timer is not active in PM3 and the bytes controlling the timer (RES, Timer_H, Timer_L) are disregarded and can be omitted from the command as well.

Sleep Time is calculated according to the following formula:

$$\text{Sleep Time} = ((\text{RES} * \text{TIMER}(\text{H}\&\text{L})) / 32.768\text{khz})$$

Sleep modes must last for a minimum of 11.08ms.

Firmware History:

- v1.0 - v1.1-4: Only PM3 supported, command is <0xCC><0x86><0x03>
- v1.1-6 - v2.1: PM2 and PM3 supported, command is <0xCC><0x86><Mode><RES><Timer_H><Timer_L>
- v2.2 - forward: PM2 and PM3 supported, both prior commands are supported

Reset

The OEM Host issues this command to perform a soft reset of the transceiver. Any transceiver settings modified by CC commands will revert to the values stored in the EEPROM.

Restore Factory Defaults

In firmware v1.7 and forward, the OEM can issue this command to restore the original factory EEPROM settings to the module. The Command also issues a reset as well as restoring the EEPROM. The default EEPROM will be active following the reset.

Command: <0x41> <0x54> <0x2B> <0x2B> <0x2B>
<0x0D>

Number of Bytes Returned: 4

Response: <0xCC> <0x43> <0x4F> <0x4D>

Command: <0xCC> <0x41> <0x54> <0x4F> <0x0D>

Number of Bytes Returned: 4

Response: <0xCC> <0x44> <0x41> <0x54>

Command: <0xCC> <0x86> <Mode> <RES> <Timer_H>
<Timer_L>

Number of Bytes Returned: None

Response: None

Parameter Range:

<Mode> = 0x02 = PM2

0x03 = PM3

<RES> = 0x00 = 2⁰

0x01 = 2¹

0x02 = 2²

0x03 = 2³

<Timer_H/TIMER_L> = 0x0001 - 0xFFFF

Command: <0xCC> <0xFF>

Number of Bytes Returned: None

Response: None

Command: <0xCC> <0xFF> <0xDF>

Number of Bytes Returned: 0

Response: None

**CONFIGURING
THE LT2510**

STATUS COMMANDS

Check Status Registry

In firmware v2.2 and forward, the Status Registry contains error codes which may be useful for the OEM to note.

- Note:**
- Sleep crystal is only checked on boot.
 - Wake Event is written every time the module wakes from sleep.
 - Boot Error is written on boot.
 - Calibration Event indicates that the module is performing a calibration of the external crystal used to track the length of sleep during a Sleep Timer sleep mode. If Sleep Calibration is enabled in the EEPROM, this bit will always be set. The sleep timer will constantly be calibrated.

Check Firmware Status

In firmware v2.6 and forward, the Check Firmware Status command is used to verify proper loading of the firmware. Because v2.6 and forward requires the firmware to be loaded via multiple images, this command verifies that all pages have been upgraded. Should an error be encountered, the first page encountered that is out-of-date is reported in the response.

Bin Analyzer

The Bin Analyzer is a powerful command for understanding the link conditions between two radios over the entire frequency hopping spectrum. The Bin Analyzer will cause the local radio to send an RSSI request packet to the radio specified in the Destination Address field. The remote radio will respond with RSSI information and this is then streamed to the OEM through the Serial UART. This sequence occurs once per hop.

Due to the random frequency hopping sequence of the radios, it is not possible to associate a specific bin # with a specific frequency, though the OEM can use the Bin Analyzer response to identify any possible interferers and to provide a quantitative analysis of the total number of good versus bad bins.

The Bin Analyzer command will stream data results back for each hop until the command is turned off or the number of runs is met. The Bin Analyzer command must be issued from Command Mode, but it will continue to stream results back even after the OEM has exited Command Mode. The Bin Analyzer packet is sent as part of the RF Packet Header and does not affect the throughput of data between two radios. See the RSSI section of the manual for equations to convert RSSI to a dBm value.

Command: <0xCC> <0x00> <0x01>

Number of Bytes Returned: 5

Response: <0xCC> <Response[32bits]>

Parameter Range:

- <Response> =
- bit 0: Sleep Crystal check- If set Sleep timing crystal failed to start
 - bit 1: Wake Event-If set, the radio was awakened from sleep with the Sleep Interrupt (Force 9600) pin
 - bit 2: Boot Error-If set, last reset was due to brown-out or power-on reset. If not set, then reset was due to uP_Reset pin or Soft Reset command.
 - bit 3: Calibration Event- If set, then the sleep timer is performing a calibration.

Command: <0xCC><0x00><0x02>

Response: <0xCC><0x02><Error><Page>

Parameter Range:

- <Error> = 0x00: success, 0x09: firmware not complete
- <Page> = 0x00: no error, 0x10-0x1E: corresponds to first page in memory that needs to be upgraded

Command: <0xCC> <0x8F> <Control> <NumRuns>

Number of Bytes Returned: 2

Response: <0xCC> <0x01>

Bin Response Stream: <0xCC> <Bin#> <RSSI_1>
<RSSI_2>

Parameter Range:

- <Control> = 0x00= Turn Bin Analyzer Off
0x01= Turn Bin Analyzer On
- <NumRuns> = 0x00= Continuous
0x01- 0xFF= Number of runs [bins]
- <Bin#> = Bin# from 0 to max bin number according to the selected RF Profile
- <RSSI_1> = How strongly the remote radio heard the local radio's bin request
- <RSSI_2> = How strongly the local radio heard the remote radio's response

**CONFIGURING
THE LT2510**

COMMAND DESCRIPTIONS

Read Temperature

The OEM Host issues this command to read the onboard temperature sensor.

Note: The temperature sensor is uncalibrated and has a tolerance of $\pm 3^{\circ}\text{C}$. For calibration instructions, contact Laird Technologies' technical support.

Change Channel

The OEM Host issues this command to set a new RF Channel Number.

Change Server/Client

The OEM Host issues this command to set the module as a Server or a Client on the fly.

Set Broadcast Mode

The Host issues this command to set the addressing mode in the radio. If both Broadcast Mode and Auto Destination are enabled, the radio will send the RF packets in Broadcast Mode.

Read IRAM

This command is used to view the IRAM contents. The IRAM contains the active (in memory) copy of the EEPROM parameters. Some of these fields are available for reading and writing to provide on-the-fly instantaneous setting of parameters. Parameters changed via the IRAM commands will take effect immediately and will remain in effect until the radio is reset. IRAM changes do not persist after a reboot.

Restrictions on the specific IRAM parameters are the same as for the EEPROM parameters.

Available locations in IRAM are:

Name	Address
Range Refresh	0x3D
RF Channel	0x41
Interface Timeout	0x58
RF Packet Size	0x5A
CTS_On_H	0x5C
CTS_On_L	0x5D
CTS_Off_H	0x5E
CTS_Off_L	0x5F
Max Power	0x63
Destination MAC Address 3	0x72
Destination MAC Address 2	0x73
Destination MAC Address 1	0x74
Destination MAC Address 0	0x75
System ID	0x76

Command: <0xCC> <0xA4>

Number of Bytes Returned: 2

Response: 0xCC <Temp.>

Parameter Range:
<Temp.> = Temperature (Celsius) in two's complement format

Command: <0xCC> <0x02> <Channel>

Number of Bytes Returned: 2

Response: <0xCC> <Channel>

Parameter Range:
<Channel> = 0x00 - 0x4E RF Channel to use

Command: <0xCC> <0x03><Data>

Number of Bytes Returned: 3

Response: <0xCC> <Firmware Version><Status>

Parameter Range:
<Data> 0x02 = Server
0x03 = Client
<Firmware> = Radio Firmware version
<Status> = 0x02: Server
= 0x03: Clients In Range
= 0x01: Client not In Range

Command: <0xCC> <0x08> <Data>

Number of Bytes Returned: 2

Response: <0xCC> <Data>

Parameter Range:
<Data> = 0x00: Disable Broadcast Mode
0x01: Enable Broadcast Mode

Command: <0xCC> <0x0A> <Location>

Number of Bytes Returned: 2

Response: <0xCC> <Value>

Parameter Range:
<Location>: [Dependant of parameter]
<Value>: 0x00-0xFF

**CONFIGURING
THE LT2510**

COMMAND DESCRIPTIONS

Write IRAM

This command is used to change the IRAM contents. The IRAM contains the active (in memory) copy of the EEPROM parameters. Some of these fields are available for reading and writing to provide on-the-fly instantaneous setting of parameters. Parameters changed via the IRAM commands will take effect immediately and will remain in effect until the radio is reset. IRAM changes do not persist after a reboot.

Restrictions on the specific IRAM parameters are the same as for the EEPROM parameters.

Available locations in IRAM are:

Name	Address
Range Refresh	0x3D
RF Channel	0x41
Interface Timeout	0x58
RF Packet Size	0x5A
CTS_On_H	0x5C
CTS_On_L	0x5D
CTS_Off_H	0x5E
CTS_Off_L	0x5F
Max Power	0x63
Destination MAC Address 3	0x72
Destination MAC Address 2	0x73
Destination MAC Address 1	0x74
Destination MAC Address 0	0x75
System ID	0x76

Write Destination Address

The OEM Host issues this command to the transceiver to change the Destination Address.

Read Destination Address

The OEM Host issues this command to the transceiver to read the Destination Address.

Auto Destination/Channel

The Host issues this command to change the Auto Destination setting. When issuing this command, the Auto Destination setting will only be changed if the corresponding enable bit is set. Otherwise, the command performs a read of Auto Destination. If both Broadcast Mode and Auto Destination are enabled, the radio will send the RF packets in Broadcast Mode.

Command: <0xCC> <0x0B> <Location> <Value>

Number of Bytes Returned: 3

Response: <0xCC> <Location> <Value>

Parameter Range:

<Location>: [Dependant of parameter]

<Value>: 0x00-0xFF

Command: <0xCC> <0x10> <MAC1> <MAC2>
<MAC3>

Number of Bytes Returned: 4

Response: <0xCC> <MAC1> <MAC2i> <MAC3>

Parameter Range:

0x00 - 0xFF corresponding to the 3 LSBs of the destination MAC Address. MAC3 is the LSB.

Command: <0xCC> <0x11>

Number of Bytes Returned: 4

Response: <0xCC> <MAC1> <MAC2> <MAC3>

Parameter Range:

0x00 - 0xFF corresponding to the 3 LSBs of the destination MAC Address. MAC3 is the LSB.

Command: <0xCC> <0x15> <Data>

Number of Bytes Returned: 2

Response: <0xCC> <Auto Dest>

Parameter Range:

<Auto Dest> = bit 7: Ignored
bit 6: Ignored
bit 5: Enable Modification of Auto Channel
bit 4: Enable Modification of Auto Destination
bit 3: Ignored
bit 2: Ignored
bit 1: Auto Channel
bit 0: Auto Destination

**CONFIGURING
THE LT2510**

COMMAND DESCRIPTIONS

Read API Control

The OEM Host issues this command to read the API Control byte.

Command: <0xCC> <0x16>

Number of Bytes Returned: 2

Response: <0xCC> <API Control>

Parameter Range:

<Auto Dest> = bits 7-3: 0
bit-2: Send Data Complete
bit-1: Transmit API
bit-0: Receive API

Write API Control

The OEM Host issues this command to write the API Control byte to enable or disable the API features.

Command: <0xCC> <0x17> <API Control>

Number of Bytes Returned: 2

Response: <0xCC> <API Control>

Parameter Range:

<Auto Dest> = bits 7-3: 0
bit-2: Send Data Complete
bit-1: Transmit API
bit-0: Receive API

Read Digital Inputs

The OEM Host issues this command to read the state of both digital output lines.

Command: <0xCC> <0x20>

Number of Bytes Returned: 2

Response: 0xCC <Digital Out>

Parameter Range:

<Digital Out> = bit-1: GIO_8
= bit-0: GIO_4

Read ADC

The OEM host issues this command to read the analog to digital converters at up to 12-bit resolution. Higher resolutions can cause slower responses from the command. The time required for a conversion is:
 $T_{conv} = (\text{decimation rate} + 16) * 0.23\mu\text{s}$.

In most applications this will be used to measure the input voltage (to detect reduced battery power) with $V_{cc}/3$, the temperature sensor or the Analog input pin. For the most accurate results the 1.25V internal reference should be chosen, though this would limit the OEM to a maximum A/D Input of 1.25V. $V_{cc}/3$ and the temperature sensor readings should use the internal 1.25v reference as those voltages will never exceed 1.25v.

The ADC result is represented in a two's complement form. The result is the difference between ground and the selected channel and will be a value between -2048 and 2047 with 2047 representing the maximum value where the ADC result equals the reference voltage and -2048 equals the negative of the reference voltage. The ADC cannot measure a voltage higher than the reference voltage.

Command: <0xCC> <0x21> <Data>

Number of Bytes Returned: 3

Response: 0xCC <Hi ADC> <Lo ADC>

Parameter Range:

<Data bits 7-6> = <Reference Voltage>
00: Internal 1.25V reference
10: Voltage on Vcc pin
<Data bits 5-4> = <Resolution>
00: 64 decimation rate (7 bits resolution)
01: 128 decimation rate (9 bits resolution)
10: 256 decimation rate (10 bits resolution)
11: 512 decimation rate (12 bits resolution)
<Data bits 3-0> = <Channel>
0000: AD/In (GIO_7)
1100: GND
1101: Positive Voltage Reference
1110: Temperature Sensor
1111: $V_{cc}/3$
<Hi ADC> = MSB or requested 12-bit ADC value
<Lo ADC> = LSB of requested 12-bit ADC value

Get Last RSSI

This command is used to report signal strength (RSSI) information from the last RF Packet the radio received. This command will report the signal strength of any received RF packet including the Server beacon, data packets and even RF Packets that were not intended for this radio (eg: packets with a different Destination MAC Address than this radio).

Command: <0xCC> <0x22>

Number of Bytes Returned: 2

Response: <0xCC> <RSSI>

Parameter Range:

<RSSI>: 0x00 – 0xFF

**CONFIGURING
THE LT2510**

COMMAND DESCRIPTIONS

Write Digital Outputs

The OEM Host issues this command to write both digital output lines to particular states. These states will be persistent unless overwritten by another enabled function (such as Hop Frame).

Write PWM Output

The PWM output is a square wave with a 630.1uS period. The PWM ratio is the ratio of the high pulse time to the Low pulse time. A value of 0x00 will output a continuous Low signal. A ratio of 0xFF will output a continuous high signal. A ratio of 0x80 will put out a repeating pulse of 315.05uS high and 315.05uS Low.

Set Max Power

The OEM Host issues this command to adjust the maximum output power.

Max Power settings are typical and can vary by 2dBm. The maximum output power will never exceed +8dBm for PRM210/211/220/221 or TBD for PRM212/213/222/223.

EEPROM Byte Read

Upon receiving this command, a transceiver will respond with the desired data from the EEPROM addresses requested by the OEM Host.

EEPROM Byte Write

Upon receiving this command, a transceiver will write the data byte to the specified address but will not echo it back to the OEM Host until the EEPROM write cycle is complete.

Vendor ID

This command is used to set the Vendor ID in the radios. The Vendor ID is a one-time writable parameter which is not able to be read back for security purposes. Radios with the Vendor ID set will only communicate to other radios that have Vendor ID set to the same value. Once the Vendor ID is set it cannot be changed. Setting this value incorrectly will result in a radio which will not be able to communicate with other radios on the network. Setting the Vendor ID is not necessary for the radios to operate and care should be taken when using it. To see if the Vendor ID has been set the OEM can issue the command <0xCC> <0xF2> <0x06> <0xFF> <0xFF>. If the response is 0xFF 0xFF then VID has not been set. If the response is 0x00 0x00, then the VID has been set. Issuing the command <0xCC> <0xF2> <0x06> <0xFF> <0xFF> will not set the Vendor ID.

Command: <0xCC> <0x23>

Number of Bytes Returned: 2

Response: 0xCC <Digital Out>

Parameter Range:
<Digital Out> = bit-1: GIO_1
= bit-0: GIO_0

Command: <0xCC> <0x24> <PWM Ratio>

Number of Bytes Returned: 2

Response: 0xCC <0x24>

Parameter Range:
<PWM Ratio> = 0x00 -0xFF, the ratio of the high pulse versus the Low pulse for a single period.

Command: <0xCC> <0x25><Max Pwr>

Number of Bytes Returned: 2

Response: 0xCC <Max Pwr>

Parameter Range:
<Max Power> PRM210/211/220/221 PRM212/213/222/223
0x00: 7.5 dBm typical 0x00: TBD
0x01: 4 dBm typical 0x01: TBD
0x02: 0 dBm typical 0x02: TBD
0x03: -4 dBm typical 0x03: TBD

Command: <0xCC> <0xC0> <Start> <Length>

Number of Bytes Returned: 4+

Response: <0xCC> <Start> <Length> <Data>

Parameter Range:
<Start> = EEPROM address to begin reading at
<Length> = Length of data to be read
<Data> = Requested data

Command: <0xCC> <0xC1> <Start> <Length> <Data>

Number of Bytes Returned: 3

Response: <Start> <Length> <Last byte>

Parameter Range:
<Start> = EEPROM address to begin writing at
<Length> = Length of data to be written
<Data> = Data to be written
<Last byte> = Value of last byte written

Command: <0xCC> <0xF2> <0x06> <Vid_H> <Vid_L>

Number of Bytes Returned: 2

Response: <0xCC> <0xF2> <0x06> <Value>

Parameter Range:
<Vid_H> = 0x00-0xFF
<Vid_L> = 0x00-0xFF
<Value> = If Vid is set the response will be 0x00 0x00. If Vid is not set the response will be 0xFF 0xFF

**SERIAL FIRMWARE
UPGRADES**

OVERVIEW

In FW versions 1.3.x and above it is possible to upgrade the active firmware running on the module via the serial interface. The Windows OEM Configuration Utility v5.07 and above can perform this operation for modules with access to a PC, but for embedded applications it may be necessary for the OEM to program the FW upgrade through a microcontroller. Upgrade of the FW over the air is not supported on the LT2510. The firmware upgrade procedure will not affect the radio EEPROM settings except to update the version number.

UPGRADING VIA WINDOWS OEM CONFIGURATION UTILITY

Upgrading through the OEM Configuration Utility is a straight-forward process. The PC Settings tab has an option when the LT2510 is the selected product to perform a Radio Firmware Update. This section of the OEM software can be used to upgrade the FW of the radio connected to Port 1 of the software.

To perform a firmware upgrade:

1. Connect the Development Kit or other interface board with the LT2510 to the PC.
2. Select the Find Ports button, then select the appropriate Windows Comm Port from the drop down
 - a. Note, if the appropriate port doesn't appear, use the Add Ports button to add the port manually, then repeat step 2.
3. Set the correct settings for the radio in Port 1. By default this is 115,200-8-N-1 with Hardware Handshaking Enabled.
4. Verify that the Port Status in Port 1 is "Open"
5. In the Radio Firmware Upgrade box, select Firmware Upgrade
6. In the Open File Window that appears select the appropriate LT2510 FW binaries.
7. When the download is successful, a Success window will appear and the new firmware is now active.
8. Send the <0xCC><0x00><0x02> command to the radio from the Command page to verify that all pages have been upgraded. If this command reports an error, locate the corresponding binary image and repeat this process with that file.

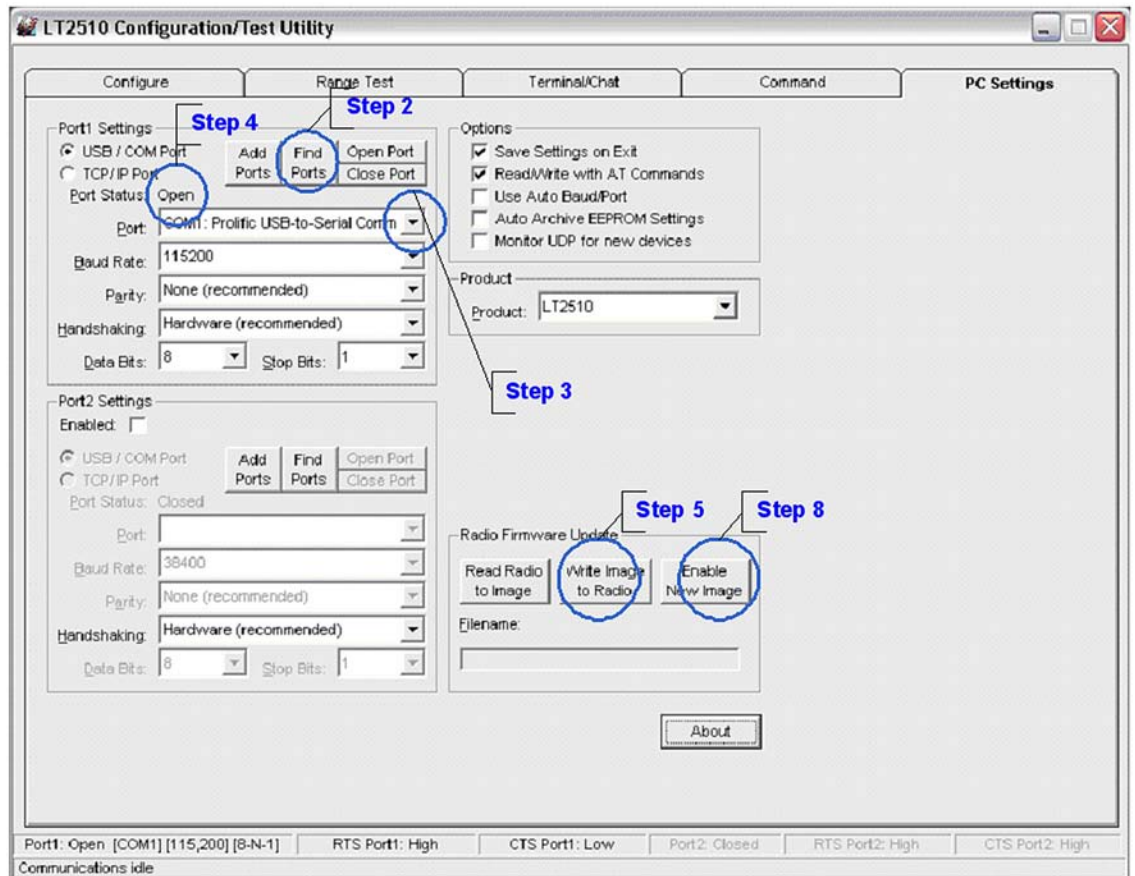

**SERIAL FIRMWARE
UPGRADES**

UPGRADING FW COMMANDS

These commands are used to upgrade the FW on the LT2510, these commands are only valid on FW version 1.3 and above.

COMMAND DESCRIPTIONS

Write Flash

This command is used to write an encrypted binary file to the reserve flash. The OEM should first issue the Erase Flash command before writing a new image to the flash. Writes can only be done in increments less than 256 bytes. The Binary file should start being written at address 0x00 and incremented from there.

Command: <0xCC> <0xC4> <StartAddress[1,0]>
<Length[1,0]> <BytesToWrite>

Number of Bytes Returned: 5

Response: <0xCC> <0xC4> <Result> <StartAddress[1,0]>

Parameter Range:

<StartAddress[1,0]>: 0x00 0x00 – 0x3B 0xFF

<Length[1,0]>: 0x00 0x01 – 0x00 0xFF

<BytesToWrite>: The actual data being written

<Result>	0x00	No Error
	0x03	Command Timed Out
	0x06	Bounds Exceeded (Start Address + Length is outside the image download area)
	0x04	A valid image already exists, erase that Flash before overwriting.

Decrypt New Image

This command is used to decrypt the binary file that was previously downloaded to the radio. The next reboot of the module will cause this decrypted image to be loaded into the memory. Once the file is decrypted, it cannot be read from the module.

Command: <0xCC> <0xC5>

Number of Bytes Returned: 3

Response: <0xCC> <0xC5> <Data>

Parameter Range:

<Data>	0x00	No Error
	0x01	Error in File integrity, erase Flash and retry download
	0x02	Not enough free memory. Reset the module and try again.
	0x04	Image Already Decrypted

Erase New Image From Flash

It is not necessary to issue this command. Radio automatically erases the new image upon loading it into active memory. However, if the wrong image is loaded the image can be erased. It is not possible to overwrite a downloaded image without erasing it or activating it. This command erases the memory between addresses 0x0000 and 0x7FFF. Memory between addresses 0x800 and 0x3BFF is erased automatically by the first write exceeding to address 0x800 or higher. Because this memory contains active code, the radio will now disconnect from the network until the upgrade process is completed.

Command: <0xCC> <0xC6>

Number of Bytes Returned: 2

Response: <0xCC> <0xC6>

Parameter Range:

SERIAL FIRMWARE UPGRADES

COMMAND DESCRIPTIONS

Read Flash

This command is used to read the encrypted image of the flash that resides on the radio module. If the image has already been decrypted, then this command will report an error.

*The length of this command is dictated by the dynamic memory heap. If the heap is mostly free, then a length of up to 700 bytes could be accepted. However, if the heap is full, the command will return with an error, or possibly no response at all if the heap is completely full.

Command: <0xCC> <0xC9> <StartAddress[1,0]>
<Length[1,0]>

Number of Bytes Returned: 5

Response: <0xCC> <0xC9> <Result> <StartAddress[1,0]>
<Data>

Parameter Range:

<StartAddress[1,0]>: 0x00 0x00 – 0x3A 0xFF

<Length[1,0]>: 0x00 0x00 – 0x02BC

<BytesToWrite>: The actual data being written

<Result>	0x00	No Error
	0x03	Command Timed Out
	0x06	Bounds Exceeded (Start Address + Length is outside the image download area)
	0x04	Image Already Decrypted
	0x02	Not Enough Free Memory, try the command again with a shorter Length

<Data>:Contents of Flash

PROCESS TO MANUALLY UPGRADE LT2510

Using the above AT commands it is possible to upgrade a LT2510 over the UART from a microcontroller or other device. The basic steps to do this are:

1. Make sure the OEM Host has a copy of an encrypted binary firmware upgrade files.
2. Erase the Existing flash on the LT2510
 - a. Command: 0xCC 0xC6
 - b. Response: 0xCC 0xC6
3. Write binary images to flash . Note that the firmware is loaded in multiple images. The primary image (the file denoted as “[00]”) MUST be sent first. The first write to memory location 0x800 or above will incur a 300ms delay while the memory between addresses 0x800 and 0x3BFF is erased. Because this memory contains active code, the radio will now disconnect from the network until the upgrade process is completed.
 - a. While not end of binary file
 - i. Command: 0xCC 0xC4 0x00 0x00 0x00 0x80 <80 bytes of data>
 - ii. Response: 0xCC 0xC4 0x00 0x00 0x00
 - b. Check EEPROM Write
 - i. Command 0xCC 0xC9 0x00 0x00 0x00 0x80
 - ii. Response: 0xCC 0xC9 0x00 0x00 0x00 0x80 <80 bytes of data>
 - c. Verify Read response is the same data that was written
 - d. Increment start position
 - e. Verify length
 - f. Repeat steps a-f until entire image has been loaded
4. Decrypt FW image
 - a. Command: 0xCC 0xC5
 - b. Response: 0xCC 0xC5 0x00
5. Reset radio to begin using new FW image
 - a. Command: 0xCC 0xFF
6. Repeat steps 2-5 for each binary file.

API OPERATION

API Operation is a powerful alternative to the default Transparent operation of the LT2510 and provides dynamic packet accounting abilities to the OEM Host without requiring extensive programming by the OEM Host. API operation utilizes specific packet formats. The API features can be used in any combination that suits the OEM's specific needs and can be different between radios operating on the same network.

API SEND DATA COMPLETE

API Send Data complete can be used as a software acknowledgement indicator. When a radio sends an addressed packet, it will look for a received acknowledgement (transparent to the OEM Host). If an acknowledgement is not received, the packet will be retransmitted until one is received or all retries have been exhausted.

For applications where data loss is not an option, the OEM Host may wish to monitor the acknowledgement process using the API Send Data Complete. If an acknowledgement is not received (failure), the OEM Host can send the packet to the transceiver once again. Because the Send Data Complete is reliant upon a successful RF Acknowledgement from the receiving radio a false positive is not possible, but a false negative may occur. That is, the receiving radio may have received the packet successfully, but the acknowledgement was not received at the transmitting radio. For Broadcast packets, the Send Data Complete will always report success.

API Send Data Complete is enabled when bit-2 of the API Control (Address 0xC1) byte is enabled. The transceiver sends the OEM Host the data shown in Figure 1 upon receiving an RF acknowledge or exhausting all attempts.

FIGURE 1: SEND DATE COMPLETE PACKET FORMAT

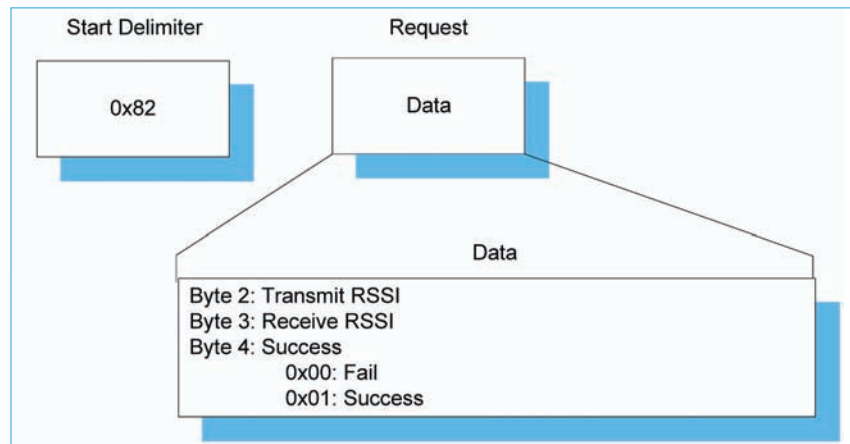

API OPERATION

API RECEIVE PACKET

By default, the source MAC is not included in the received data string sent to the OEM Host. For applications where multiple radios are sending data, it may be necessary to determine the origin of a specific data packet. When API Receive Packet is enabled, all packets received by the transceiver will include the MAC address of the source radio as well as an RSSI indicator which can be used to determine the link quality between the two.

API Receive Packet is enabled when bit-0 of the API Control (Address 0xC1) byte is enabled. Upon receiving a RF packet, the radio sends its OEM Host the data as shown in Figure 2 below.

FIGURE 2: RECEIVE API PACKET FORMAT

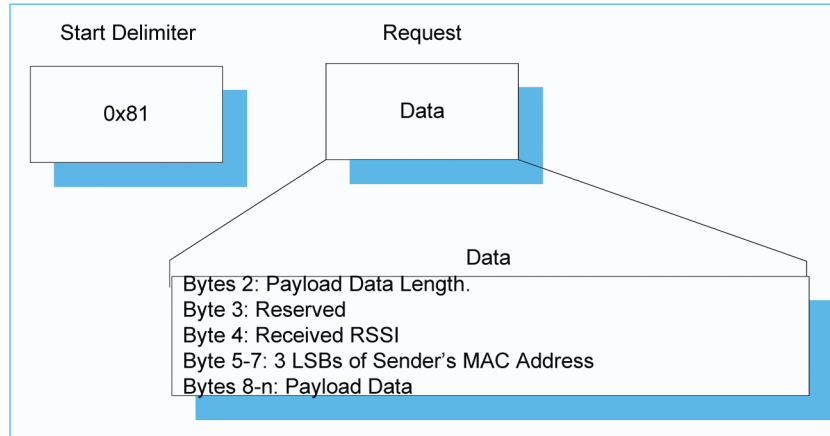

API TRANSMIT PACKET

API Transmit Packet is a powerful API Mode that allows the OEM Host to send data to a single or multiple (via Broadcast) transceivers on a packet-by-packet basis. This can be useful for many applications; including polling networks and mesh networks.

API Transmit Packet is enabled when bit-1 of the API Control (address 0xC1) byte is enabled. The OEM should pre-pend each packet of data with the following header information.

FIGURE 3: TRANSMIT API PACKET FORMAT¹

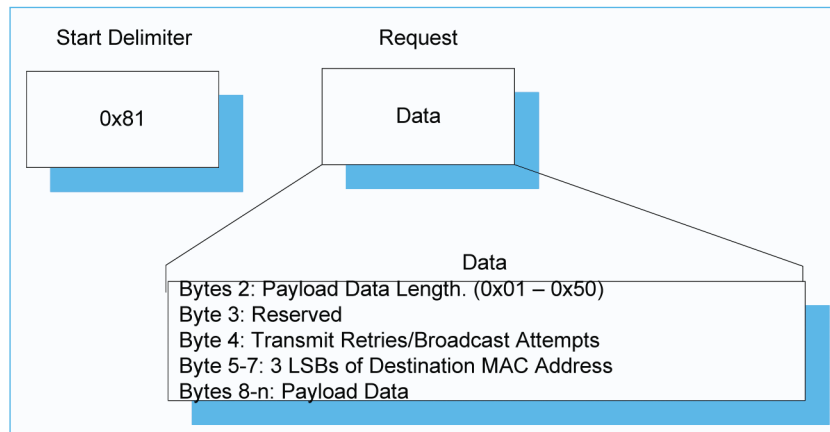

¹ Setting the Destination Address to 0xFF 0xFF 0xFF will broadcast the packet to all available transceivers in the network.

**MECHANICAL
CONSIDERATIONS**

MECHANICAL DRAWING

FIGURE 4: FORM FACTOR: SMD-ANT

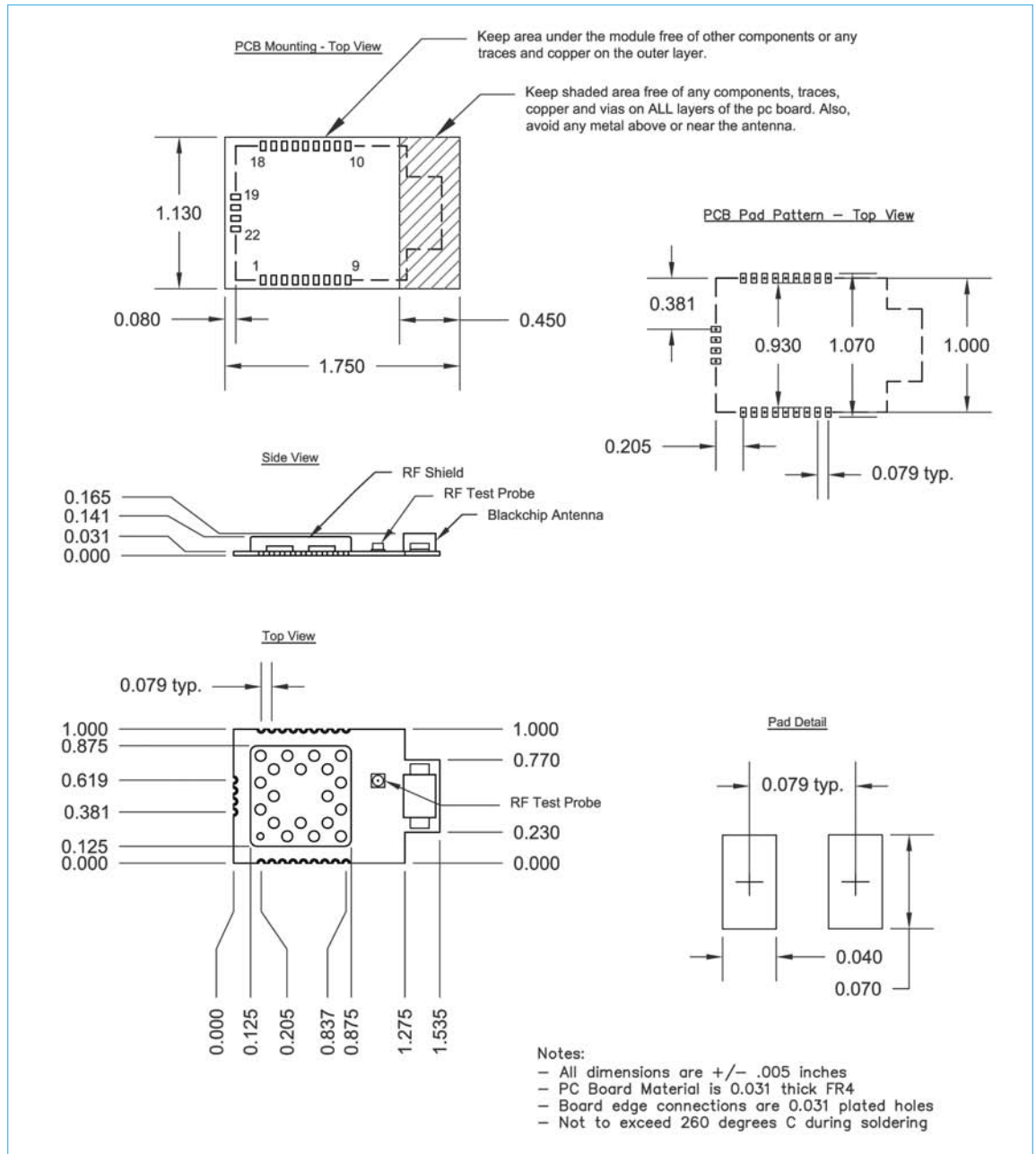

MECHANICAL CONSIDERATIONS

MECHANICAL DRAWING

FIGURE 5: FORM FACTOR: SMD-U.FL

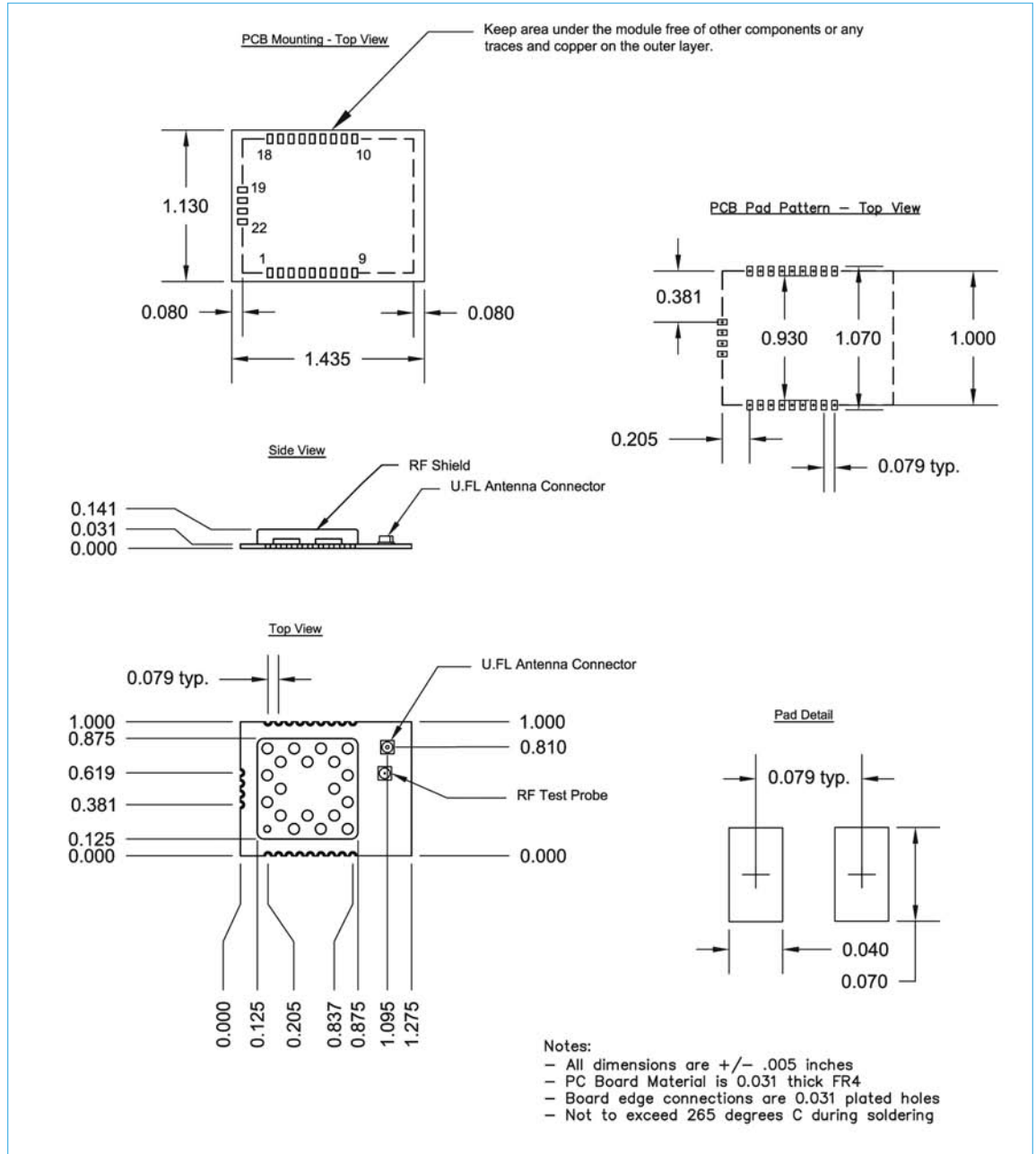

MECHANICAL
CONSIDERATIONS

MECHANICAL DRAWING

FIGURE 6: FORM FACTOR: PLUGGABLE

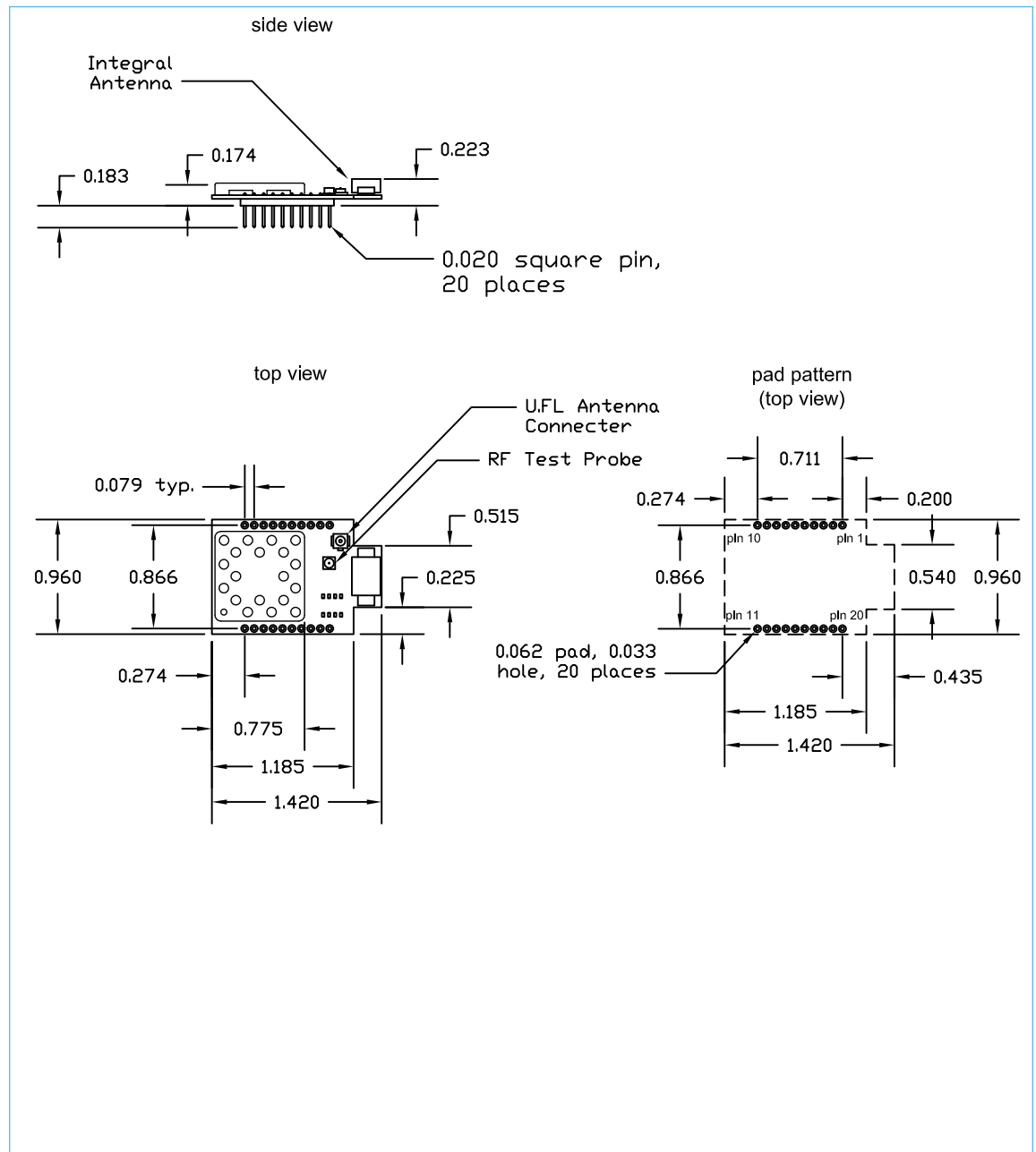

The Pluggable LT2510 uses a single row header with 2mil spacing. The Mill Max 831-43-010-10-001000 is used on the LT2510 development kit as a mating connector.

MECHANICAL CONSIDERATIONS

MECHANICAL DRAWING

FIGURE 7: FORM FACTOR: SMT MODULE

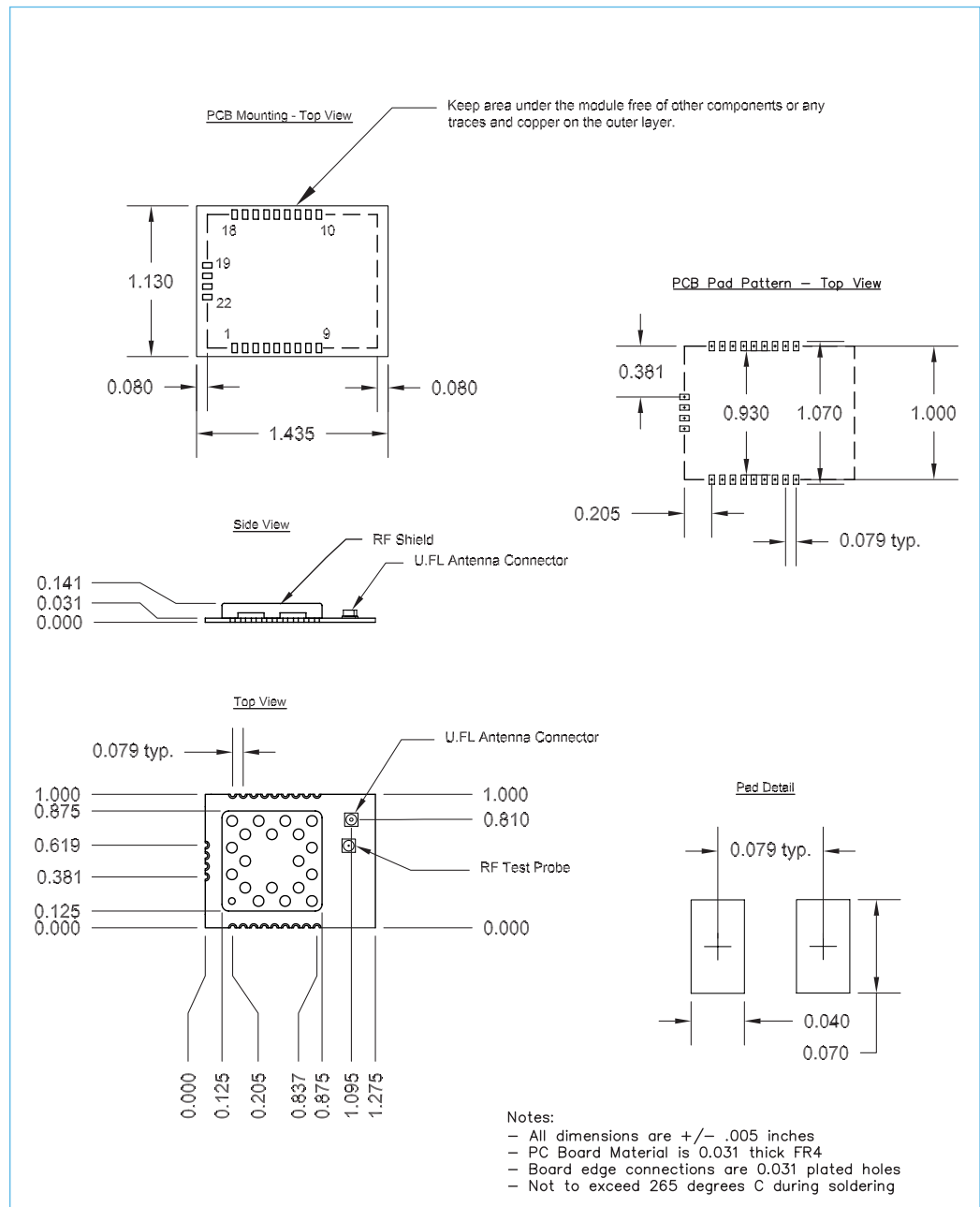

FIGURE 7: MOISTURE CONTENT WARNING



CAUTION

Level

3

This bag contains
MOISTURE-SENSITIVE DEVICES

1. Shelf life in sealed bag: 24 months at $< 40^{\circ}\text{C}$ and $< 90\%$ relative humidity.
2. Peak package body temperature: 245°C .
3. After this bag is opened, devices that will be subjected to reflow solder or another high temperature process must be;
 - a) Mounted within 168 hours at factory conditions of $\leq 30^{\circ}\text{C}$ @ 60% RH... or...
 - b) Stored at $< 10\%$ RH
4. Devices require bake, before mounting, if;
 - a) Humidity indicator card is $>10\%$ when read at $23 \pm 5^{\circ}\text{C}$...or...
 - b) 3a or 3b is not met.
5. If baking is required, devices may be baked for 48 hrs. at $125 \pm 5^{\circ}\text{C}$.
Note: If device containers cannot be subjected to high temperature or shorter bake times are desired, reference IPC/JEDEC J-STD-033 for bake procedure.

Bag Seal Date

**ORDERING
INFORMATION**

PRODUCT PART NUMBERS

TABLE 10: LT2510 PART NUMBERS

LAIRD PART NUMBER	DESCRIPTION	FCC ID*	IC	ETSI (CE)	JAPAN
PRM110	125mW (+21 dBm) LT2510, SMT with U.FL connector	KQL-2510100P	2268C-2510100P		
PRM111	125mW (+21 dBm) LT2510, SMT with chip antenna	KQL-2510100P	2268C-2510100P		
PRM112	50mW (+17 dBm) LT2510, SMT with U.FL connector	KQL-2510100P	2268C-2510100P	EN 300 328-2 v1.71, EN 301 489	
PRM113	50mW (+17 dBm) LT2510, SMT with chip antenna	KQL-2510100P	2268C-2510100P	EN 300 328-2 v1.71, EN 301 489	
PRM120	125mW (+21 dBm) LT2510, Pluggable with U.FL connector	KQL-2510100P	2268C-2510100P		
PRM121	125mW (+21 dBm) LT2510, Pluggable with chip antenna	KQL-2510100P	2268C-2510100P		
PRM122	50mW (+17 dBm) LT2510, Pluggable with U.FL connector	KQL-2510100P	2268C-2510100P	EN 300 328-2 v1.71, EN 301 489	005WWCA0358
PRM123	50mW (+17 dBm) LT2510, Pluggable with chip antenna	KQL-2510100P	2268C-2510100P	EN 300 328-2 v1.71, EN 301 489	005WWCA0359

*PRM110 and PRM111 with hardware revisions 0050-0157 Rev0 through 0050-00157 Rev 1 have an FCC ID of KQL-2510100 and an IC number of 2268C-2510100.

TABLE 11: LT2510 DEVELOPMENT KITS PART NUMBERS

PART NUMBER	DESCRIPTION	REGULATORY
DVK-PRM110	Full Development Kit with one USB Eval Board and one RS-232 Eval Board containing the PRM110 radios	FCC/IC
DVK-PRM111	Full Development Kit with one USB Eval Board and one RS-232 Eval Board containing the PRM111 radios	FCC/IC
DVK-PRM112	Full Development Kit with one USB Eval Board and one RS-232 Eval Board containing the PRM112 radios	CE/FCC/IC
DVK-PRM113	Full Development Kit with one USB Eval Board and one RS-232 Eval Board containing the PRM113 radios	CE/FCC/IC
DVK-PRM120	Full Development Kit with one USB Eval Board and one RS-232 Eval Board containing the PRM120 radios	FCC/IC
DVK-PRM121	Full Development Kit with one USB Eval Board and one RS-232 Eval Board containing the PRM121 radios	FCC/IC
DVK-PRM122	Full Development Kit with one USB Eval Board and one RS-232 Eval Board containing the PRM122 radios	FCC/IC/CE/Japan
DVK-PRM123	Full Development Kit with two PRM123 radios	FCC/IC/CE/Japan

**COMPLIANCY
INFORMATION**

APPROVED ANTENNA LIST

The following antennas are approved for operation with the LT2510 for use in North America and select markets as identified.

This device has been designed to operate with the antennas listed below, and having a maximum gain of 9dB. Antennas not included in this list or having a gain greater than the maximum allowed are strictly prohibited for use with this device. The required antenna impedance is 50 Ohms.

TABLE 12: LT2510 APPROVED ANTENNA LIST*

LAIRD TECHNOLOGIES PART NUMBER	MANUFACTURER PART NUMBER	MANUFACTURER	TYPE	GAIN (dBi)
	WIC2450-A	Laird Technologies	Chip	2
	IG2450-RS36	Laird Technologies	Omni	6
	ID2450-RS36	Laird Technologies	Panel	9
0600-00039	S151-6-PX-2450S	Nearson	Dipole	5
0600-00040	S181-6-PX-2450S	Nearson	Dipole	2
	WCP2400	Laird Technologies	Dipole	2
2150-00006	NZH2400-MMCX	Laird Technologies	Dipole	1

* The OEM is free to choose another vendor's antenna of like type and equal or lesser gain as an antenna appearing in the table and still maintain compliance

**COMPLIANCY
INFORMATION**

FCC/IC REQUIREMENTS FOR MODULAR APPROVAL

In general, there are two agency classifications of wireless applications; portable and mobile.

Portable: Portable is a classification of equipment where the user, in general, will be within 7.87in (20cm) of the transmitting antenna. Portable equipment is further broken down into two classes; within .98in (2.5cm) of human contact and beyond .98in (2.5cm). The LT2510 is not agency approved for portable applications. The OEM is required to have additional testing performed to receive this classification. Contact Laird Technologies for more details.

Mobile: Mobile defines equipment where the user will be 7.87in (20cm) or greater from the transmitting equipment. The antenna must be mounted in such a way that it cannot be moved closer to the user with respect to the equipment, though the equipment may be moved.

This equipment has been approved for mobile applications where the equipment should be used at distances greater than 7.87in (20cm) from the human body. Operation at distances of less than 7.87in (20cm) would require additional RF exposure evaluation, including SAR requirement according to FCC RF exposure guideline.

Notes: This equipment has been tested and found to comply with the limits for a Class B digital device, pursuant to Part 15 of the FCC Rules. These limits are designed to provide reasonable protection against harmful interference in a residential installation.

This equipment generates, uses and can radiate radio frequency energy and, if not installed and used in accordance with the instructions, may cause harmful interference to radio communications. However, there is no guarantee that interference will not occur in a particular installation. If this equipment does cause harmful interference to radio or television reception, which can be determined by turning the equipment off and on, the user is encouraged to try to correct the interference by one or more of the following measures:

- Reorient or relocate the receiving antenna.
- Increase the separation between the equipment and receiver.
- Connect the equipment into an outlet on a circuit different from that to which the receiver is connected.
- Consult the dealer or an experienced radio/TV technician for help.

**COMPLIANCY
INFORMATION**

OEM EQUIPMENT LABELING REQUIREMENTS

WARNING: The OEM must ensure that FCC labeling requirements are met. This includes a clearly visible label on the outside of the OEM enclosure specifying the appropriate Laird Technologies FCC identifier for this product as well as the FCC notice below. The FCC identifiers are listed above.

Contains FCC ID: KQL-2510100
The enclosed device complies with Part 15 of the FCC Rules. Operation is subject to the following two conditions: (1) This device may not cause harmful interference, and (2) This device must accept any interference received, including interference that may cause undesired operation.

Label and text information should be in a size of type large enough to be readily legible, consistent with the dimensions of the equipment and the label. However, the type size for the text is not required to be larger than eight point.

ANTENNA REQUIREMENTS

To reduce potential radio interference to other users, the antenna type and gain should be chosen so that the equivalent isotropically radiated power (e.i.r.p.) is not more than that permitted for successful communication.

WARNING: This device has been tested with a U.FL connector with the above listed antennas. When integrated into the OEM's product, these fixed antennas require professional installation preventing end-users from replacing them with non-approved antennas. Any antenna not listed in the above table must be tested to comply with FCC Section 15.203 for unique antenna connectors and Section 15.247 for emissions. Contact Laird Technologies for assistance.

CAUTION: Any changes or modifications not expressly approved by Laird Technologies could void the user's authority to operate the equipment.

WARNINGS REQUIRED IN OEM MANUALS

WARNING: This equipment has been approved for mobile applications where the equipment should be used at distances greater than 7.87in (20cm) from the human body. Operation at distances of less than 7.87in (20cm) is strictly prohibited and requires additional SAR testing.

REGULATORY INFORMATION

CE APPROVED ANTENNA LIST

Part Numbers PRM112, PRM113, PRM122 and PRM123 are approved for use in CE Markets with antennas having a maximum gain of 2.5dBi. Antennas having a gain greater than the maximum allowed are strictly prohibited for use with this device. The required antenna impedance is 50 Ohms.

CE TESTED ANTENNA LIST*

LAIRD TECHNOLOGIES PART NUMBER	MANUFACTURER PART NUMBER	MANUFACTURER	TYPE	GAIN (DBI)
	WIC2450-A	Laird Technologies	Chip	2
0600-00040	S181-6-PX-2450S	Nearson	Dipole	2
	WCP2400	Laird Technologies	Dipole	2
2150-00006	NZH2400-MMCX	Laird Technologies	Dipole	1

* The OEM is free to choose another vendor's antenna of equal or lesser gain as an antenna appearing in the table and still maintain compliance. Antennas listed in this table have been tested with the LT2510.

JAPAN APPROVED ANTENNA LIST

Part Numbers PRM122 and PRM123 are approved for use in Japanese Markets with the antennas listed below. The required antenna impedance is 50 Ohms.

JAPAN APPROVED ANTENNA LIST

LAIRD TECHNOLOGIES PART NUMBER	MANUFACTURER PART NUMBER	MANUFACTURER	TYPE	GAIN (DBI)
	WIC2450-A	Laird Technologies	Chip	2
0600-00040	S181-6-PX-2450S	Nearson	Dipole	2

INDICATIONS OF SYMBOLS ON EQUIPMENT

The symbols listed below shall be indicated on the main unit of the radio equipment. The symbols in the same format shall be indicated also on the package. The following figure is intended to serve as an example. Refer to ARIB STD-T66 for details.

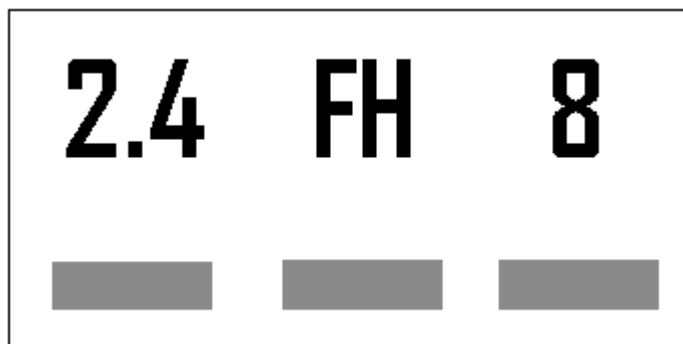

ANATEL CERTIFICATIONS FOR BRAZIL

The following part numbers PRM110, PRM111, PRM120 and PRM121 are approved for use in Brazil. Contact your sales representative about ordering fully certified modules that have been customized to meet Anatel regulations.

“Este produto está homologado pela ANATEL, de acordo com os procedimentos regulamentados pela Resolução 242/2000, e atende aos requisitos técnicos aplicados”

Para maiores informações, consulte o site da ANATEL www.anatel.gov.br

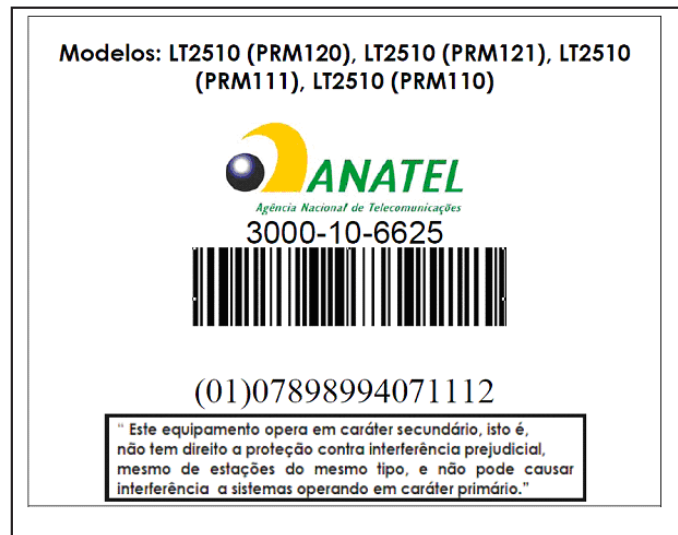

LT2510 FIRMWARE HISTORY

This section will detail key differences between firmware releases of the LT2510. The previous sections of the User Manual only deal with the latest version. Some features and default settings have changed from one firmware to the next. This section will detail those differences.

Hardware changes:

On PCB 00157 Rev 0 and Rev 1, the FCC ID is KQL-2510100 and the IC number is 2268C-2510100

On PCB 00157 Rev 2, pin 13 at the connector was swapped with pin 20.

On PCB 00157 Rev 2 and forward the FCC ID is KQL-2510100P and the IC number is 2268C-2510100P

FW1.0-3

- Initial Release.
- This version has an issue which permits received RF packets that fail CRC check to be forwarded across the UART.
- This version has an issue which permits a Client RF packet to collide with a Server RF packet in Full Duplex mode.
- Baud rates \leq 4800 baud will drop a byte when sending packets over the serial interface larger than the RF Packet Size.
- The Bin Analyzer command reports the incorrect bin number.
- The module does not work properly below 0°C.

FW 1.1-4

- CRC issue present in 1.0-3 was corrected. This correction makes a v1.0-3 radio incompatible over the air with any newer versions of the Firmware.
- Fixed Full Duplex Mode issue.

FW 1.1-6

- Changed Deep Sleep AT Command from CC 86 003 to CC 86 03 00 00 00. The new command is backwards compatible, but the old command is no longer relevant.

FW1.2-5

- RF Data Rate (EEPROM bytes 0x51-0x53) has been superseded by the RF Profile byte (EEPROM 0x54). RF Profile is the preferred method to set the RF Data Rate and number of Hops.
- Reduced RX Buffer from 768 bytes to 512 bytes and increased the heap memory to 1800 bytes. All serial and RF packets are now routed through the heap. CTS_ON and CTS_Off only reflect the memory usage of the 512 byte RX buffer. The RX buffer will never fill unless the heap becomes full.
- 9-bit mode released.
- Fixed issue with baud rates \leq 4800.
- Fixed issue with temperatures below 0°C

FW1.4-1

- Serial firmware upgradeability feature was added. Firmware versions prior to v1.4 do not support field upgradeability.
- Reset radio and restore factory defaults command (0xCC 0xFF 0xDF) was added. This command will reload the factory default EEPROM command.

FW1.5-0

- Added profile 0x03 (280kbps RF data rate, 43 hops). This profile is legal for both FCC and CE markets. Profile 0x02, which also supports 280kbps and 43 hops, is only permitted in FCC markets. The two profiles are not over the air compatible with each other.

FW1.6

- Prior to this release, Auto Config could only correctly set Interface Timeout if a standard baud rate was used. Selecting non-standard baud rates required Auto Config to be disabled and Interface Timeout to be set by the user. This version and forward, Interface Timeout can be set by the radio regardless of baud rate selection, provided Auto Config is disabled.
- Added RS-485 Driver Enable control pin.
- Added RSSI functionality to the PWM output pin.
- Added Vendor ID.
- Prior to this release, pin 13 (GI_0) was configured as an output. It is now an input.
- Added 485 DE-RE to Auto Config. If Auto Config is disabled, 485 DE-RE Delay must be set manually.

FW 1.9

- Corrected issue with Deep Sleep command where the module would sometimes remain awake after issuing the command.

FW2.0

- Corrected issue with FIFO buffer which could have resulted in lost packets when using Broadcast transmissions.

LT2510 FIRMWARE HISTORY

FW 2.1

- Added hop delineation for transmissions
- Moved 485 timers from Auto Config when Address 0x57 bit 5 is set.
- Added Auto Destination on Beacon only. By default the Auto Destination feature will address the transceiver to the last packet it received, whether it is a beacon from the server or a data packet sent from any radio. By setting Address 0x56 Bit 7, the module will only auto destination based on the beacon from the server.

FW 2.4-1

- Added Sleep Timer Mode
- Added Remote I/O Mode
- Added Beacon Skip
- Added Discard Framing Error Packets
- Corrected 9-bit issues which only permitted 9-bit to work with mark and space parity
- Fully implemented sleep modes
- Eliminated bottleneck between TX serial interface and RF receive buffer
- Added Auto Destination on Beacons Only
- Removed RS485 DE/RE timing control from Auto Config and moved to its own control
- Added Hop Packet Delineation
- Added Sniff Report
- Added Sleep Pin Indicator
- Added Status Request Error Report command

FW 2.6-0

- There is a known issue that v2.6-0 cannot be upgraded and must first be downgraded to v2.4-1 and then upgraded to any version.

FW 2.9-0

- Fixed a problem where a Client occasionally and suddenly goes out of range of the Server about twice a week on average. This has been present since inception.
- Fixed a problem where, rarely, the Enter AT Command could be treated as transparent data and get transmitted over the RF. This has been present since v2.1-0.
- Fixed a problem where Random Backoff is calculated on every attempt to send a packet; even the first attempt. It should not be calculated on the first attempt. This issue has been present since inception.
- Fixed a problem where Remote RSSI is not reported correctly by Send Data Complete and Bin Analyzer commands. This has been present since v1.6-0.
- Fixed a problem where a radio with Sniff Report enabled was prevented from acknowledging a unicast packet for which it was the destination. This has been present since v2.4-1.
- Added Disable Status Bin to optionally reduce average current by 1mA.
- Added support for the LT1110 family (PRM-2xx) of 900MHz modules. While this does not affect the LT2510 in any way, it provides the benefit that the same code base is used for both product families.
- To accommodate a larger firmware image, the upgrade procedure has been modified. The commands all remain the same, but there are nuances that are noted in this manual.

global solutions: local support..

Americas: +1.800.492.2320

Europe: +44.1628.858.940

Asia: +852.2268.6567

wirelessinfo@lairdtech.com

www.lairdtech.com/wireless