

BW18BL
50 litre thermoelectric beverage
centre
BW28BL
70 litre thermoelectric beverage
centre

INSTRUCTION MANUAL

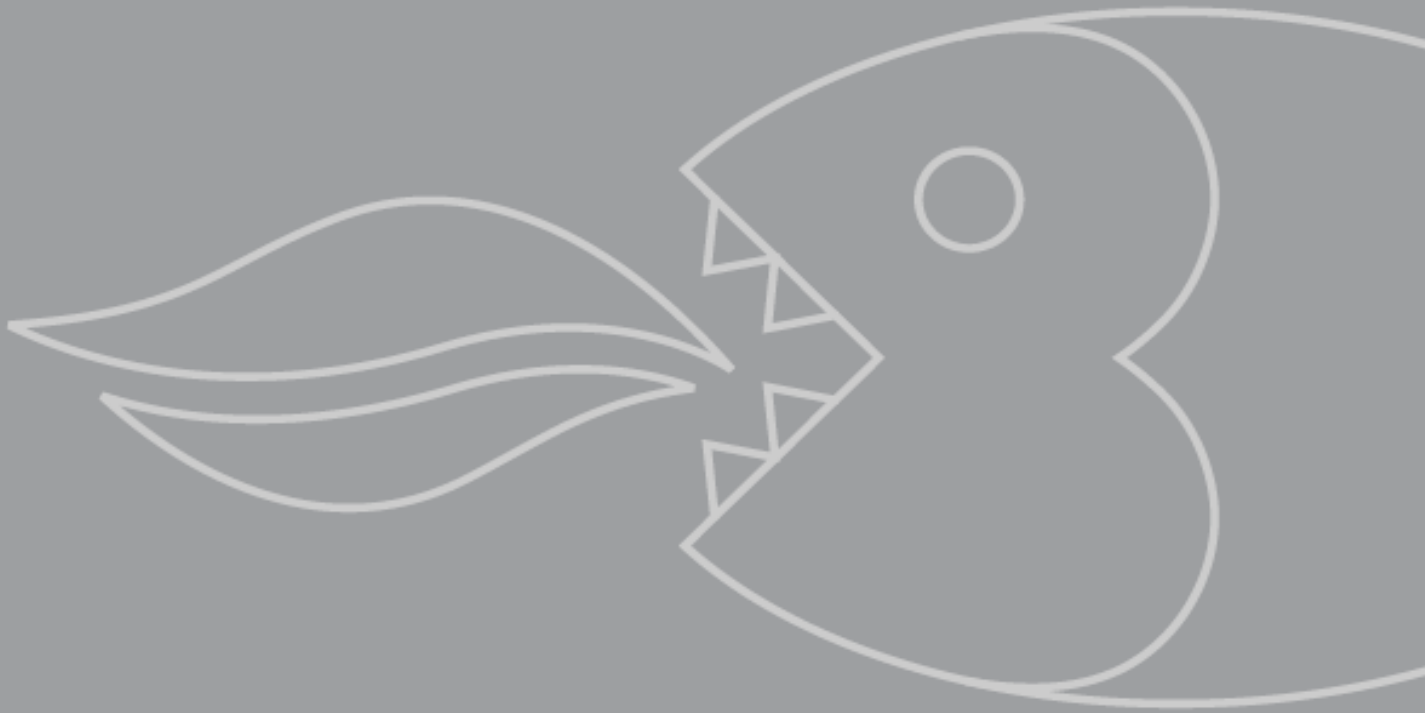

USER MANUAL FOR YOUR BAUMATIC

**BW18BL 50 litre thermoelectric
beverage centre**

**BW28BL 70 litre thermoelectric
beverage centre**



NOTE: This User Instruction Manual contains important information, including safety & installation points, which will enable you to get the most out of your appliance. Please keep it in a safe place so that it is easily available for future reference, for you or any person not familiar with the operation of the appliance.

DD 12/10/11

Contents

Environmental note	4
Important safety information	5 – 6
Specifications of your beverage centre cooler	7-10
BW18BL	7
BW28BL	8
Description of the appliance	9
Description of the product features	10
Using your Baumatic beverage centre	11-13
Before switching on	11
During first use	11
Setting the temperature	12
Interior light	13
Loading the beverage centre	13
Removing a shelf	13
Replacing a shelf	13
Cleaning and maintenance	14-15
Defrosting	15
Installation	16-19
Electrical connection	16-17
Positioning	17
Reversing the door	18-19
Troubleshooting	19-20
Baumatic consumables	21
Contact details	22

Environmental note

Note: Before discarding an old appliance, switch off and disconnect it from the power supply. Cut off and render any plug useless. Cut the cable off directly behind the appliance to prevent misuse. This should be undertaken by a competent person. Disable the door lock to make sure that children cannot get stuck inside the appliance.

This appliance is marked according to the European directive 2002/96/EC on Waste electrical and Electronic Equipment (WEEE). By ensuring this product is disposed of correctly, you will help prevent potential negative consequences for the environment and human health, which could otherwise be caused by inappropriate waste handling of this product.

The symbol  on the product, or on the documents accompanying the product, indicates that this appliance may not be treated as household waste. Instead it shall be handed over to the applicable collection point for the recycling of electrical and electronic equipment.

Disposal must be carried out in accordance with local environmental regulations for waste disposal.

For more detailed information about treatment, recovery and recycling of this product, please contact your local city office, your household waste disposal service or the shop where you purchased the product.



- The packaging materials that Baumatic uses are environmentally friendly and can be recycled.
- Please discard all packaging material with due regard for the environment.

Important safety information



Your safety is of the utmost importance to Baumatic. Please make sure that you read this instruction booklet **before** attempting to install or use the appliance. If you are unsure of any of the information contained in this booklet, please contact the Baumatic Advice Line.

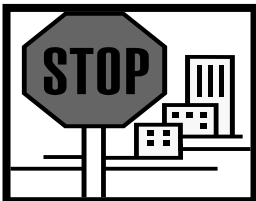

IMPORTANT: Any installation work must be carried out by a qualified electrician or competent person.

Use of the appliance

- Your appliance is only designed to be used in the home. It is suitable for storing and chilling beverages. NO food stuffs must be stored in the appliance. If it is used for any other purpose or it is not used correctly, then Baumatic Ltd. will accept no liability for any damage that is caused.



- Altering the specification of the appliance must not be attempted for reasons of safety.
- Do not place any objects on top of the appliance, as this may damage the table top.



Before using your appliance

- Check the appliance for any signs of transport damage. If you notice any damage, then you should not connect your appliance to your mains supply and should contact your retailer.

Child safety

- Packaging material should be kept away from children.
- Children should not be allowed to touch the controls or play with the appliance.



General safety

- Do not pull on the power supply cable to remove the plug from your mains supply socket.
- Do not pull out or insert the plug with wet hands.
- Do not attempt to use your appliance outdoors or any place where it is likely to come into contact with the elements.
- Before cleaning the appliance or performing maintenance work, ensure that the appliance has been disconnected from your mains supply.
- Always ensure that the location where you are installing your appliance is free of stored items such as papers and other flammable materials.
- Never block the ventilation openings of the appliance, either on the inside or its exterior.
- It is vital to keep your appliance well ventilated, so that there is proper air flow between the bottom of the unit and the plinth/kick plate which it is sitting on.
- Do not place electrical devices inside of the appliance, such as mixers or ice cream makers.

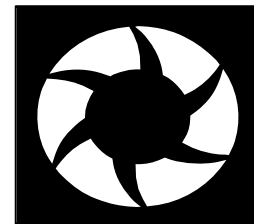
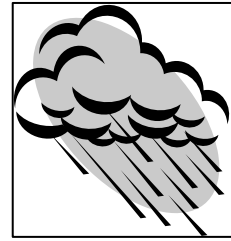

Service

You should not attempt to repair the appliance yourself, as this could cause injury or a more serious malfunction. If you require a service call then please contact the Baumatic Customer Care Department.

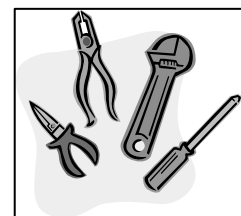

Specifications of your beverage centre

BW18BL

- Gross capacity: 50 litres
- Net capacity: 48 litres
- Energy efficiency class: C
- Noise level: 38 dB
- Fan assisted operation
- Thermo-electric 'Peltier' system
- Quiet operation
- No compressor (vibration free)
- 5 waved chrome shelves
- Adjustable temperature
- Internal light
- Tempered door glass
- Adjustable feet
- Reversible door (***only from serial number: 10300001***)
- Smoked door glass
- Black door frame
- Black interior and exterior

Dimensions of appliance*

Height:	645 mm
Width:	355 mm
Depth:	500 mm

* Please refer to the installation instructions for more specific information on the size of aperture that you will require.

BW28BL

- Gross capacity: 70 litres
- Net capacity: 65 litres
- Energy efficiency class: F
- Noise level: 38 dB
- Fan assisted operation
- Thermo-electric 'Peltier' system
- Quiet operation
- No compressor, vibration free
- 6 wire shelves
- Adjustable temperature
- Internal light
- Tempered door glass
- Adjustable feet
- Reversible door (**only from serial number: 10300001**)
- Smoked door glass
- Black door frame
- Black interior and exterior

Dimensions of appliance*

Height: 735 mm
Width: 460 mm
Depth: 540 mm

* Please refer to the installation instructions for more specific information on the size of aperture that you will require.

IMPORTANT: When you install your appliance it is important to bear in mind its climatic rating.

In order to find out the climatic rating of your appliance, you should check the rating plate. The rating plate is located inside the appliance, on the top left front corner. The rating plate will indicate the ambient temperature range that your appliance will function correctly within.

It is also advisable to make a note of the model number and the serial number of the appliance before installing it.

Model number

Serial number

Date of purchase

Description of the appliance (BW18BL)

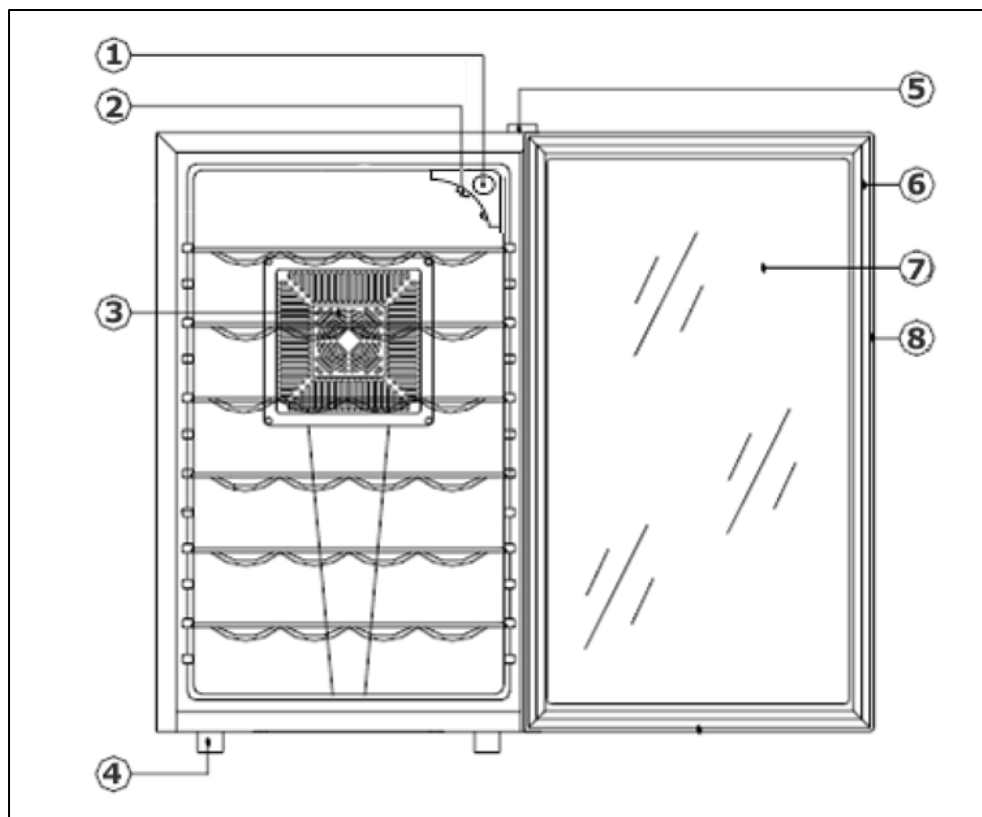

- 1) Temperature control dial
- 2) Light ON/OFF switch
- 3) Adjustable shelves (x 5)
- 4) Adjustable feet (x 4)
- 5) Hinge cover
- 6) Door seal
- 7) Door glass
- 8) Door

Description of the appliance (BW28BL)

- 1) Temperature control dial
- 2) Light ON/OFF switch
- 3) Adjustable shelves (x 6)
- 4) Adjustable feet (x 4)
- 5) Hinge cover
- 6) Door seal
- 7) Door glass
- 8) Door

Description of the product features

1) Temperature control dial

- The temperature control dial is located at the top right hand corner of the appliance, behind the glass door. It should be turned to set the temperature that the beverage centre is chilling at.
- The temperature control dial is located at the front of the beverage centre, in the top right hand corner.

2) One cooling zone

- There is one cooling zone inside of your beverage centre.
- **IMPORTANT:** The temperature of the appliance will be warmer at the top of the cooling zone and cooler at the bottom.

3) Interior light

- The cooling zone has an interior light. The light can be switched on and off by using the light ON/OFF switch **(2)**.

4) The shelves

- Any of the shelves can be removed, to accommodate larger bottles.

Using your Baumatic beverage centre

Before switching on

- Make sure that it has been installed by a suitably qualified person, as per the information contained in Baumatic's installation instructions.
- The outside of the appliance and the removable accessories contained within it, should be cleaned with a solution of liquid detergent and water.
- The interior of the appliance should be cleaned with a solution of sodium bicarbonate dissolved in lukewarm water. The interior and accessories should be thoroughly dried, after the cleaning process has been completed.
- There can be an odour when you first switch on the appliance. It will lessen as the appliance starts to cool.

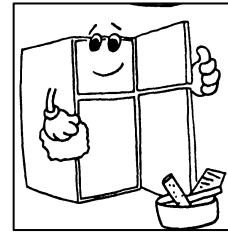

During first use

- When you first switch on the appliance, the appliance will run continuously until the beverage centre reaches a cool enough temperature. **IMPORTANT:** It may take up to 36 hours for the beverage centre to reach its optimum working temperature.
- During this period of time, you should try not to open the door frequently or place bottles or cans inside of the appliance.
- If the unit is switched off or unplugged, you must allow at least 5 minutes before restarting the appliance or reconnecting it to your mains supply.

Setting the temperature

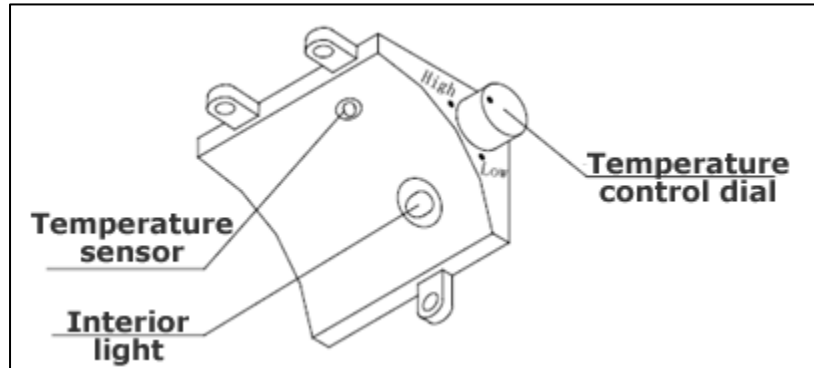

- When the appliance is connected to your mains supply, the power ON light will switch on.
- Use the temperature control dial to set the temperature within the beverage centre.
- If you set the control dial to the word "Low", then the beverage centre will achieve a lower temperature.
- If you set the control dial to the word "High", then the beverage centre will achieve a higher temperature.
- The beverage centre can achieve a temperature of between 12°C and 18°C at / below 25°C ambient.

Interior light

- To operate the interior light, you should use the light ON/OFF switch **(2)**.

Loading the beverage centre



- **IMPORTANT:** Whilst the beverage centre can store larger bottles, you must make sure that they do not prevent the door from shutting properly.
- Always check that you can close the door without it fouling on a bottle or can before shutting it.
- When loading several beverages at once, it will take longer for the appliance to cool the individual bottles or cans.

Removing a shelf

- Remove all of the bottles from the shelf that you want to remove.
- Lift the shelf upwards and then gently pull the shelf away from the beverage centre.

Replacing a shelf

- Place the shelf back into a supporting guide slot and push it back as far as it will go.

Cleaning and maintenance

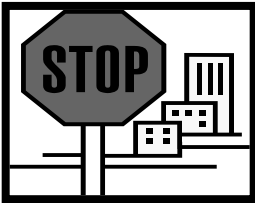

WARNING: PLEASE ENSURE THAT YOUR APPLIANCE IS DISCONNECTED FROM YOUR MAINS SUPPLY BEFORE ATTEMPTING TO CLEAN IT.

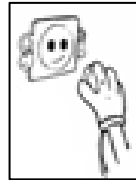

- Do not clean the appliance by pouring water onto it or spraying water over it.



- The interior of the beverage centre should be cleaned periodically, using a solution of bicarbonate of soda and lukewarm water.

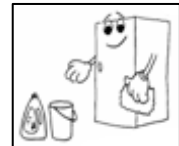

- Clean the accessories separately with soap and water. Do not clean them in a dishwasher.

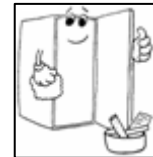

- Do not use abrasive products, detergents or soaps.



- After washing the appliance, wipe over the area that you have cleaned with a damp cloth and then dry it thoroughly.
- When cleaning is complete, dry your hands and then reconnect the plug to your mains supply.

Defrosting

- Defrosting occurs automatically inside of the beverage centre during operation. The defrost water is collected by the evaporating tray and evaporates automatically.
- The evaporating tray and defrost water drain hole should be cleaned periodically. This will prevent water from collecting in the bottom of the beverage centre, instead of flowing down the defrost drainage channel and drain hole.
- You can also pour a small amount of water down the drain hole to clean inside of it.
- You should be careful to make sure that bottles or cans do not touch the rear wall of the appliance, as this can interrupt the automatic defrosting process and deflect water into the base of your beverage centre.

Installation

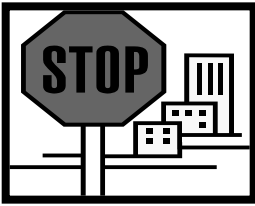

IMPORTANT: Before installation and usage read all the instructions and make sure that the voltage (V) and the frequency (Hz) indicated on the rating plate are exactly the same as the voltage and frequency in your home. The rating plate can be found on the front left edge of the inside of the beverage centre.

The manufacturer declines all responsibility in the event of the installer failing to observe all the accident prevention regulations in force, which are necessary for normal use and the regular operation of the electric system.

Electrical connection



YOUR BEVERAGE CENTRE IS INTENDED FOR FITTED AND PERMANENT INSTALLATION.

We recommend that the appliance is connected by a qualified electrician, who is a member of the N.I.C.E.I.C. and who will comply with the I.E.E. and local regulations.

- Your beverage centre comes supplied with a 13 amp plug fitted. If in future you need to change the fuse in this plug, then a 13 amp ASTA approved (BS 1362) fuse **must** be used.
- The wiring in the mains lead is coloured as follows:

Brown	Live
Blue	Neutral
Green and yellow	Earth

- As the colours of the wires in the appliance's mains lead may not correspond with the coloured markings identifying the terminals in your spur box, please proceed as follows:

The **brown wire** must be connected to the terminal marked "L" (live), or coloured **red**.

The **blue wire** must be connected to the terminal marked "N" (neutral), or coloured **black**.

The **green and yellow wire** must be connected to the terminal marked "E" (earth), or by the earth symbol, or coloured **green and yellow**.

- When the connection is completed, no stray strands or cut wire should be present. The cord clamp must be secured over the outer sheath.

Positioning

- It is advisable that your appliance is only installed in a location where the ambient temperature of the room, corresponds with the climate classification that is stated on the rating plate of your appliance. Your appliance may not function correctly if the ambient temperature falls outside of the following ranges.

<i>Climate classification</i>	<i>Appropriate ambient temperature</i>
SN	+10 to +32 degrees centigrade
N	+16 to +32 degrees centigrade
ST	+18 to +38 degrees centigrade
T	+18 to +43 degrees centigrade

- Positioning the appliance requires two people in order to avoid injuries or damage to the appliance.
- Your appliance should not be located in direct sunlight or exposed to continuous heat or extremes of temperature (e.g. next to a radiator or boiler). If this is not feasible, then you should install an insulation plate between the appliance and the adjacent heat source.
- You should check whether there is an electrical socket available, which will be accessible after your appliance is installed.
- Place the appliance flatly and firmly on a solid base. The appliance is fitted with adjustable feet on the front side, which can be used to level the appliance.
- Anything positioned above the appliance must be at least 100 mm away to allow sufficient cooling of the condenser. You must also allow a 100 mm gap to the rear and a 50 mm gap either side of the appliance.
- Be sure to leave enough space for the opening of the door, to avoid damage to the appliance or personal injury.
- ***IMPORTANT: The vent at the base of the appliance is for ventilation. Nothing should be placed in front of this vent; otherwise your beverage centre may not operate properly.***

Reversing the door

(This option is only available from serial number: 10300001)

The beverage centre door is able to open from the left or right side. The door is originally manufactured to open from the left side however you can change this to the right side by following the instructions below.

IMPORTANT: Before reversing the door, the appliance must be disconnected from the power supply. All parts removed must be saved to reinstall the door.

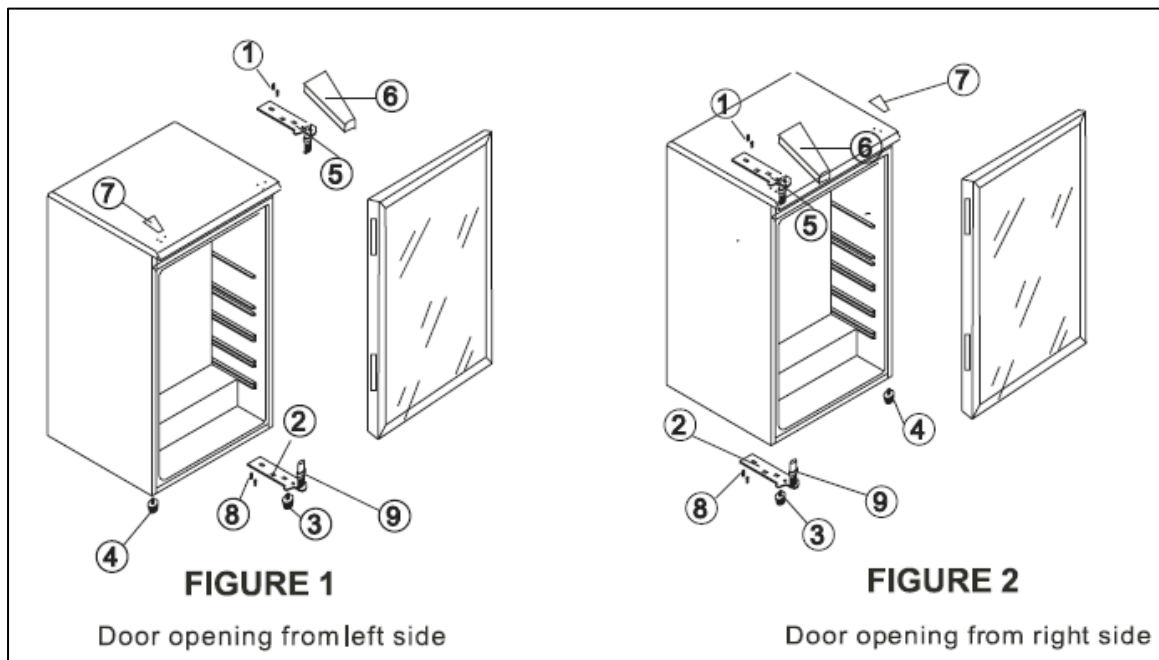

- Remove the upper hinge cover **(6)** first.
- Remove the 3 screws **(1)** that hold the upper hinge **(5)** (right side) to the frame. Take away the upper hinge **(5)**.
- Lift the door and place it on a padded surface to prevent scratching.
- Remove the 3 screws **(8)** that hold the lower hinge **(2)**. Remove the lower hinge **(2)**.
- Remove the left front feet **(4)** and transfer to the right side.
- Remove the hole cover plate **(7)** to the right side.
- Before replacing the lower hinge **(2)**, remove the bolt-pin **(9)** and reverse the direction of the lower hinge **(2)**. Install the lower hinge **(2)** onto the left side of the lower frame with the 3 screws **(8)**.

- Insert the bolt-pin **(9)** into the lower hinge **(2)**.
- Set the door in its place making sure it sits on the lower hinge **(2)**.
- While holding the door in the closed position secure the upper hinge **(5)** on the top left hand side with the 3 screws **(1)**. Do not tighten the 3 screws **(1)** until the top of the door is levelled with the counter top.
- Install the upper hinge cover **(6)** on the upper hinge.

Troubleshooting



IMPORTANT: *If your beverage centre appears not to be operating properly, before contacting the Baumatic Customer Care Department, please refer to the checklist below.*

PROBLEM	POSSIBLE CAUSE
Appliance does not operate	Not plugged in. The circuit breaker has tripped or the fuse has blown.
Temperature inside the appliance is too warm.	The temperature controls are set too warm. Set the temperature controls to a cooler setting and allow several hours for the temperature to stabilise. The door is being kept open too long or is being opened too frequently, which is allowing warm air to enter the appliance. The door is not closed completely. The door gasket is not sealing correctly. The appliance has recently been disconnected from the mains supply; it will take at least four hours for it to get down to temperature again.
Temperature inside the appliance is too cold	The temperature controls are set too cold. Set the temperature controls to a warmer setting and allow several hours for the temperature to stabilise.
Moisture is forming on the inside of the appliance.	The door is slightly open. The door is being kept open too long or is being opened too frequently. Open the door less often. The door is not sealed properly.
Moisture is forming on the outside of the appliance.	The door is slightly open, causing cold air from inside the appliance to meet warm, moist air from the outside.



IMPORTANT: If your appliance appears not to be operating correctly, then you should disconnect it from your mains supply and then contact Baumatic Customer Care on telephone number (0118) 933 6911.

DO NOT ATTEMPT TO REPAIR THE APPLIANCE YOURSELF.

Please note that if an engineer is asked to attend whilst the product is under guarantee and finds that the problem is not the result of an appliance fault, then you may be liable for the cost of the call out charge.

The appliance must be accessible for the engineer to perform any necessary repair. If your appliance is installed in such a way that an engineer is concerned that damage will be caused to the appliance or your kitchen, then he will not complete a repair.

This includes situations where appliances have been tiled in, sealed in with sealant, have wooden obstructions placed in front of the appliance, like plinths. Or any installation other than the one specified by Baumatic Ltd. has been completed.

Please refer to the conditions of guarantee that appear on the warranty card that you receive with the appliance.

Baumatic consumables

- **BC001** Degreaser for Dishwashers (200g)
- **BC002** Descaler for Washing Machines and Dishwashers (200g)
- **BC003** Ceramic Hob Cleaner (250ml)
- **BC004** Oven Cleaner (250ml)
- **BC005** Stainless Steel Cleaner and Protector (250ml)
- **BC007** E-Cloth – General Purpose Cloth
- **BC008** Microwave Cover

To order a Baumatic consumable product please call 0123 5437 244 and quote the product code. You can also order online from eshop.baumatic.co.uk



United Kingdom

Baumatic Ltd.,
Baumatic Buildings,
6 Bennet Road,
Reading, Berkshire
RG2 0QX
United Kingdom

Sales Telephone

(0118) 933 6900

Sales Fax

(0118) 931 0035

Customer Care Telephone

(0118) 933 6911

Customer Care Fax

(0118) 986 9124

Spares Telephone

(01235) 437244

Advice Line Telephone

(0118) 933 6933

E-mail:

sales@baumatic.co.uk
customercare@baumatic.co.uk
spares@baumatic.co.uk
technical@baumatic.co.uk

Website:

www.baumatic.co.uk

Republic of Ireland

Service Telephone

1-890 812 724

Spares Telephone

091 756 771

Czech Republic

Baumatic CR spol s.r.o.
Lípová 665
460 01 Liberec 4
Czech Republic

+420 483 577 200

www.baumatic.cz

Slovakia

Baumatic Slovakia, s.r.o.
Galvániho 7/D
Slovakia

+421 255 640 618

Germany

Baumatic GmbH
Lilienthalstrasse 1
320 52 Herford
Deutschland

+49 5221 694 99-0

www.baumatic.de

Italy

Baumatic Italia S.R.L.
Via Galvani N.3
35011 Campodarsego (PD)

+3904 9920 2297

www.baumatic.it

Holland

Baumatic Benelux B.V.
Grindzuigerstraat 22
1333 MS ALMERE
Nederland

+3136 549 1555

www.baumatic.nl

