



MAXIMIZER-II Progressive Nitrous Controller

INSTALLATION AND USER MANUAL

Table of Contents

	Page
1. Installation Overview.....	1
1.1 MAXIMIZER-II Power Input	1
1.2 SOLENOID DRIVER Ground.....	1
1.3 Arming Switch Input	1
1.4 O2 Sensor Input (and factory ECU).....	1
1.5 Tachometer Signal Input.....	1
1.6 TPS Signal Input	2
1.7 Trigger Inputs 1 & 2	2
1.8 General Purpose Outputs 1 & 2	2
1.9 Ignition Retard Outputs 1& 2	2
1.10 Bottle Heater Enable Input	2
1.11 Bottle Heater Control Output	2
1.12 Nitrous Pressure Sensor Harness	2
1.13 MAP Sensor Input.....	2
2. Software.....	3
2.1 Entering User Data.....	3
2.2 Main Screen	3
2.3 Program Set-up.....	4
2.3.1 General Options Tab	4
2.3.2 Miscellaneous Option Tabs.....	4
2.4 MAXIMIZER-II Configuration.....	5
2.4.1 General Tab.....	5
2.4.2 Stage 1 & 2 Tab	8
2.4.2.1 Time Based Nitrous Configuration	9
2.4.2.2 RPM Based Nitrous Configuration	9
2.4.3 Saving and Uploading your Configuration	10
2.5 Monitor and Data Logging	10
2.5.1 Monitoring	10
2.5.2 Data Logging	11
2.5.3 Data Analysis.....	11
2.6 Software Updates.....	12
3. Accessories.....	12
4. Disclaimer	13
5. Warranty	13
6. MAXIMIZER-II Wiring Diagrams.....	13
6.1 System	14
6.2 Status LED.....	15
6.3 12 volt Arming Switch.....	15
6.4 Ignition Retard.....	16
6.5 Remote Bottle Opener.....	16
6.6 Automatic Purge	17
6.7 Fuel Pressure Safety Cut-off Switch	17
6.8 WOT Switch	18
6.9 Narrowband O2 Sensor	18

1. Installation Overview

The purpose of this overview is to provide the user with some basic information about the installation and configuration.

Note: The instructions in this manual take precedence over those included with other nitrous accessories.

1.1 MAXIMIZER-II Power Input

Connect the MAXIMIZER-II's power to the same power source as the ECU (9~18 volts). Ensure the fuse rating is sufficient to power both. (This power and ground need to be "clean" in order to obtain the best performance from your MAXIMIZER-II).

DO NOT connect the MAXIMIZER-II's ground to the same place you grounded the SOLENOID DRIVER.

DO NOT install a separate switch on the white power wire. The MAXIMIZER-II's power should be controlled by the main ignition switch - see arming switch below.

Note: Powering up the MAXIMIZER-II while the engine is running may result in an inaccurate MAP reading. (see MAP sensor input)

1.2 SOLENOID DRIVER Ground

The heavy black wire from the SOLENOID DRIVER must be connected to a good ground location that can handle 40 AMPS.

DO NOT connect to the ECU ground connection. While pulsing the solenoids, this will generate large amounts of electrical noise that can interfere with the MAXIMIZER-II or your ECU.

1.3 Arming Switch Input

Grounding the arming wire arms the MAXIMIZER-II. Connect the arming wire to one side of your arming switch and connect the other side of the switch to chassis ground.

1.4 O2 Sensor Input (and factory ECU)

If you are connecting to a stand-alone 4-wire O2 sensor, all 4 wires should be connected to the sensor as identified on the Narrowband O2 Sensor wiring diagram.

For optimum performance and tuning capability, an FJO Racing Products (www.fjoracing.com) Wideband AFR System Controller is recommended. It will enable the MAXIMIZER-II to accurately display and log your air/fuel ratio. **Using the IWC0004 power cable (purchased separately), the wideband controller plugs directly into the MAXIMIZER-II without the need for a separate power connection.**

1.5 Tachometer Signal Input

The MAXIMIZER-II is designed to work with most Tachometer signals (down to 3 Volts), without the need for a separate adapter.

1.6 TPS Signal Input

The MAXIMIZER-II is designed to work with most *throttle-position-sensors* (TPS) and *wide-open-throttle* (WOT) switches.

1.7 Trigger Inputs 1 & 2

Grounding these inputs is considered the “ON” position. They can be used to enable or disable individual stages. See configuration section for more details.

1.8 General Purpose Outputs 1 & 2

These outputs can be used to turn on an LED or small panel lamp (0.5 amps max), automatically activate your remote bottle-opener, or automatically purge your nitrous line. They function like an internal switch that is open when not active and connected to ground when active. See configuration section for more details.

1.9 Ignition Retard Outputs 1& 2

These outputs can be used to retard timing provided that your ignition system supports this feature. They function like an internal switch that is either open or connected to ground when active. See configuration section for more details.

1.10 Bottle Heater Enable Input

Grounding this input is considered the “ENABLE” position for the automatic bottle heater control. This feature allows the MAXIMIZER-II to control the bottle heater relay in an attempt to maintain the target pressure. See configuration section for more details.

1.11 Bottle Heater Control Output

This output is used to turn on the bottle heater relay by grounding the negative side of the coil. See configuration section for more details.

1.12 Nitrous Pressure Sensor Harness

This harness connects directly to the nitrous pressure sensor. See configuration section for more details.

1.13 MAP Sensor Input

The MAXIMIZER-II has an integrated 48 psi pressure sensor designed to measure manifold absolute pressure (MAP). Connect the flexible hose to your intake manifold after the throttle plate.

Note: The MAXIMIZER-II calibrates the sensor at power up. If your engine is running, the sensor's pressure reading will be outside the expected range and will not be calibrated – which may result in an inaccurate reading. This is why it is recommended to connect the MAXIMIZER-II's power to your ignition switch.

2. Software

Updates and manuals are available from www.fjoracing.com

Your PC will require a serial port to connect to the MAXIMIZER-II. Some newer laptops do not have an integrated serial port and will require an optional USB-Serial adapter or a PCMCIA serial adapter. Please contact your computer equipment supplier to purchase this adapter.

Note: Due to the wide variety of these adapters available, FJO cannot guarantee a specific adapter however, our testing has shown that adapters using the Prolific Technology PL-2303 controller chip function very well.

2.1 Entering User Data

Drag & Slide – data fields that have this feature have a down arrow button to the right. Clicking and holding the button causes a slider bar to appear. Moving the mouse left or right while the slider is displayed will decrease or increase the value.

Increment/Decrement buttons - data fields that have this feature have up/down arrow buttons to the right. Click on either of these to increase or decrease the value accordingly.



Menu pull-down – data fields that have this feature have a down arrow button to the right. Clicking on the button will cause a pull-down menu to appear. To select, click on one of the displayed options.

Typing – clicking on the data field will highlight the value. You can then use the keyboard to enter the value.

2.2 Main Screen

The main screen allows you to:

- Configure the program preferences
- Configure the MAXIMIZER-II.
- Upload your saved configurations to the MAXIMIZER-II or download your configurations from the MAXIMIZER-II.
- Enter the monitor window for the MAXIMIZER-II.
- Log data to your PC

2.3 Program Set-up

To open the program configuration menu, click on **View** and **Options**.

2.3.1 General Options Tab

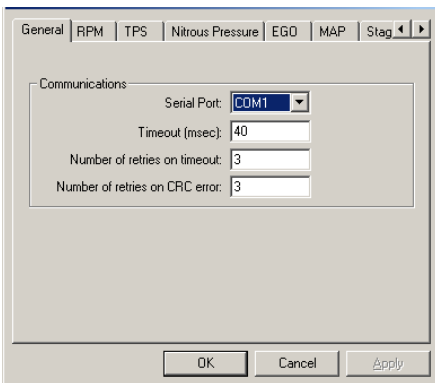

Serial Port allows you to select which COM port the software will use on your PC. Select the correct port from the drop-down menu.

Timeout sets the time that the software waits before resending a command if there was a communication error. For most PC's this should be set to **40**.

Number of retries on timeout sets the maximum retry count before the software displays a timeout error. For most PC's this should be set to **3**.

Number of retries on CRC error sets the maximum retry count before the software displays a CRC error. For most PC's this should be set to **3**.

Note: Some PC's using USB-serial converters will experience a higher error rate due to the performance characteristics of the converter. In these cases we recommend that you increase the Timeout value to 2000 to determine if this corrects the problem. Doing so will reduce the update frequency and slow down the display or logging rate.

2.3.2 Miscellaneous Option Tabs

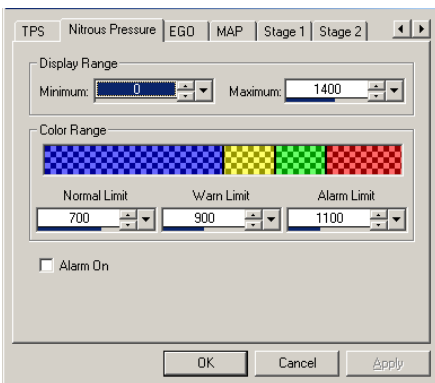

Minimum sets the minimum range value that will be displayed in the Monitor window.

Maximum sets the maximum range value that will be displayed in the Monitor window.

Normal / Warn / Alarm Limit sets the value at which the display will change color.

Alarm On will cause the PC to beep when you exceed the Alarm Limit.

2.4 MAXIMIZER-II Configuration

To start, click on **File** then **New**.

2.4.1 General Tab

EGO Present allows you to select whether or not you have an O2 signal connected to the MAXIMIZER-II. A check mark in the box tells the MAXIMIZER-II that a signal is connected.

Sensor Type allows you to set the type of sensor/controller being used. To set the type of sensor, click on the window to indicate “FJO Wideband” or “Narrow”.

Note: For optimum performance and tuning capability, an FJO Racing Products (www.fjoracing.com) Wideband AFR System Controller is recommended. It will enable the MAXIMIZER-II to accurately display and log your air/fuel ratio.

RPM Signal Present allows you to select whether or not you have a tachometer input signal connected to the MAXIMIZER-II. A check mark in the box tells the MAXIMIZER-II that a signal is connected.

RPM Multiplier selects the correct pulse count for the RPM counter. Use the following as a guide to determine the correct setting:

- a) **Using a TACH signal** - TACH signals will typically have 1 pulse per cylinder during 2 revolutions of the crankshaft (1 full cycle) and therefore the correct setting would be **÷(½ the number of cylinders)**

Example: When using a TACH signal

- 4 cylinder setting would be ÷2
- 6 cylinder setting would be ÷3
- 8 cylinder setting would be ÷4

- b) Using a trigger signal from a coil** - first determine how often it fires per revolution of the crankshaft. The correct setting would be:
- x1** for a waste-spark since it fires each revolution of the crankshaft
 - x2** for a full-sequential since it fires every other revolution.

MAP Present allows you to select whether or not you have the internal MAP sensor connected to the intake manifold of your engine. If connected, you can use the Map cutoff feature as well as log the MAP pressure. A check mark in the box tells the MAXIMIZER-II that the sensor is connected.

Ignition Retard #1 When allows you to select the mode of the internal ignition retard switch #1. When 'Grounded' indicates that the output is grounded when active. When, 'Not Grounded' indicates that the ignition retard wire is floating or not grounded when active. If your system requires a 12-volt trigger signal, refer to the wiring section or contact technical support.

Ignition Retard #2 When allows you to select the mode of the internal ignition retard switch #2.

Note: These outputs function like an internal switch that connects to ground. They can be configured to open or close when active (0.5 amps max). To use this feature you will need an ignition system with a timing retard function.

Nitrous Pressure Sensor Present allows you to select whether or not you have the nitrous pressure sensor connected to the MAXIMIZER-II. This feature allows you to use the automatic bottle heater control as well as log your bottle pressure. A check mark in the box tells the MAXIMIZER-II that the sensor is connected and enables the automatic bottle heater control.

Bottle Heater Target Pressure (only available if sensor present is checked) allows you to select the target pressure that the bottle heater will try to maintain.

Note: The automatic bottle heater function can be enabled/disabled manually via the bottle heater switch, however the controller will only enable the heater if there is sufficient pressure in the line. If the pressure is too low, the status indicator (optional) will flash slowly – once per second – and the heater will be disabled. The automatic bottle heater function DOES NOT require the MAXIMIZER-II to be armed.

Idle allows you to set the TPS idle setting.

WOT allows you to set the TPS wide-open-throttle setting.

GPO #1 and GPO #2 sets the mode that the general-purpose outputs operate as.

STATUS LED – the output will turn on when ever the MAXIMIZER-II is ARMED. If there is a fault, it will flash at 4 times per second. If your bottle pressure is too low and either the arm switch or bottle heater enable switch is on, it will flash at once per second. The fault status takes precedence over the bottle pressure status.

BOTTLE OPENER – the output will open the bottle whenever the MAXIMIZER-II is armed or the bottle heater enable switch is on. This feature requires the optional remote bottle opener control module and an electric bottle opener. It will close the bottle if both the arm switch and bottle heater enable switch are off.

AUTOMATIC PURGE – when the MAXIMIZER-II is armed, the output will automatically trigger your purge solenoid relay for the amount of time you set in the Purge Time setting. If you have the other GPO configured as BOTTLE OPENER, the AUTOMATIC PURGE will wait until the bottle open cycle is complete before doing a purge. If the bottle is already open (bottle heater enabled) it will purge immediately.

Number of Gears allows you to set the number of gear profiles. The MAXIMIZER-II can have a unique profile for each gear for each stage.

Gear Reset Time allows you to set the time in seconds that the MAXIMIZER-II will wait before setting its gear counter to the predetermined gear. This occurs *only after the MAXIMIZER-II has been armed, activated and has been left in the armed state.*

Reset To allows you to set the default gear for the gear reset time.

Transmission Type allows you to select the type of transmission (manual or automatic). If 'Manual', there is no more configuration required for Transmission.

If Automatic, proceed as follows.

Detect Gearshift Above allows you to set the minimum RPM threshold above which the MAXIMIZER-II can detect a gear change.

Trigger Gearshift Drop allows you to set the amount by which the RPM must drop before the MAXIMIZER-II will detect the change as a gear change.

Enable 4 Solenoid Single Stage allows you to set the MAXIMIZER-II into single stage mode. In this mode both channels act as a single channel allowing you to drive 2 pairs of solenoids as a single stage. A checkmark in the box enables this feature.

Enable Load Balance tells the MAXIMIZER-II to alternately pulse the solenoids. Normally channel 1 & 2 solenoids would be pulsed on and off at the same time which can cause fuel pressure and voltage dropouts. Enabling this will have the effect of reducing the load by as much as 40% during the ramp interval.

WARNING: DO NOT use this feature if your fuel and nitrous solenoids are not on the same channel.

2.4.2 Stage 1 & 2 Tab

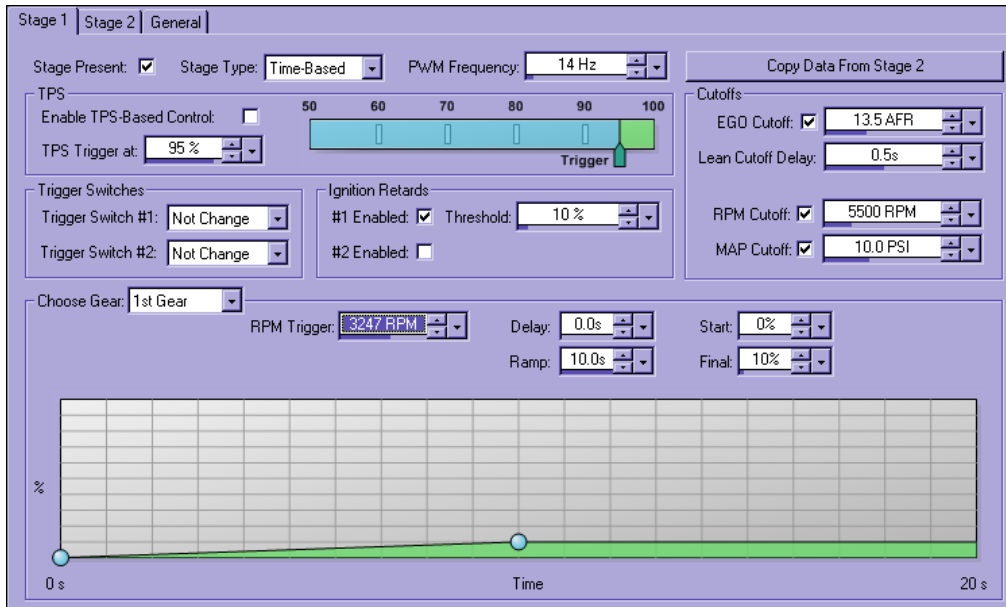

Copy Data from Stage x allows you to copy all settings from the other stage and overwrite the current stage's settings. *Be careful as there is no UNDO function – current changes will be lost.*

Stage present allows you to add or remove this stage from the MAXIMIZER-II configuration menu. Removing the check mark disables this stage regardless of any other configuration options.

Stage Type allows you to set the nitrous ramp to Time based or RPM based.

Enable TPS-based Control enables the TPS control feature. This feature allows the driver to cut back the nitrous by simply easing up on the throttle as long as the TPS stays above the trigger level. The throttle range between TPS TRIGGER AT and WOT is used to attenuate the nitrous ramp by as much as 35%.

TPS Trigger at allows you to set the throttle point above which the nitrous can be turned on.

EGO Cutoff allows you to set the lean point at which the nitrous automatically turns off. The MAXIMIZER-II will not turn the nitrous back on until it has been successfully disarmed and re-armed. The STATUS LED will flash quickly if a lean shutdown occurred.

Lean Cutoff Delay allows you set a delay for the lean cutoff function. The MAXIMIZER-II must see a lean condition for the full delay period before it will shut off the nitrous. This allows short, non-harmful lean spikes to be ignored.

RPM Cutoff allows you to set the upper RPM threshold at which the nitrous will be turned off. (useful with locked torque converters)

MAP Cutoff allows you to set the MAP pressure at which the nitrous will be turned off. (useful with large turbo applications where nitrous is used to compensate for turbo lag)

Trigger Switch #1 and Trigger Switch #2 can be configured to ENABLE, DISABLE or NOT CHANGE the arm status of a stage. (useful with a trans-brake, fuel pressure switch, or manual override)

Choose Gear selects the gear that the current nitrous ramp profile is for.

2.4.2.1 Time Based Nitrous Configuration

This mode uses the traditional Nitrous vs. time ramp.

RPM Trigger allows you to set the minimum RPM required before the Nitrous can be triggered.

Delay allows you to set the time that the MAXIMIZER-II must wait before initiating the Nitrous after all conditions have been met to activate the Nitrous.

Start allows you to select the amount of Nitrous that will be applied at the beginning of the ramp. Set the Start by dragging the blue dots on the graph to the desired settings or by using the methods described in the *Entering User Data* section.

Final allows you to set the maximum amount of Nitrous that will be applied. This can be set by dragging the blue dots on the graph to the desired settings or by using the methods described in the *Entering User Data* section.

Ramp allows you to set the time taken from the START of the Nitrous to the FINAL. This can be set by dragging the blue dots on the graph to the desired settings or by using the methods described in the *Entering User Data* section.

2.4.2.2 RPM Based Nitrous Configuration

This mode uses the Nitrous vs. RPM ramp.

RPM Trigger allows you to set the minimum RPM required before the Nitrous can be triggered.

RPM End allows you to set the RPM at which you reach the nitrous level set in FINAL. This can be set by dragging the blue dots on the graph to the desired settings or by using the methods described in the *Entering User Data* section.

Start allows you to select the amount of Nitrous that will be applied at the beginning of the ramp. Set the Start by dragging the blue dots on the graph to the desired settings or by using the methods described in the *Entering User Data* section.

Final allows you to set the maximum amount of Nitrous that will be applied. This can be set by dragging the blue dots on the graph to the desired settings or by using the methods described in the *Entering User Data* section.

2.4.3 Saving and Uploading your Configuration

It is recommended that you save your configuration and log files in the directory

C:\Program Files\NX MAXIMIZER-II II

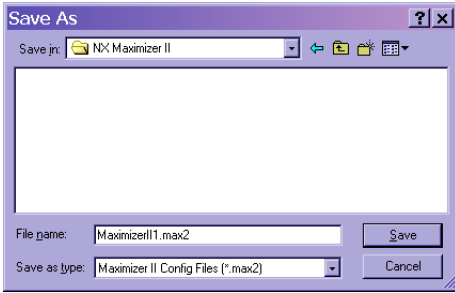

To save your configuration on the PC, click on **File** then **Save As...** and enter a name for the configuration. It is possible to save multiple configurations on the PC, but only one config can be loaded into the MAXIMIZER-II.

To upload a saved configuration to the MAXIMIZER-II, ensure the MAXIMIZER-II is turned on. Open the desired configuration and click on the **UPLOAD** button (green arrow pointing to car).

To download a configuration from the MAXIMIZER-II, ensure the MAXIMIZER-II is turned on. Open a default configuration by clicking on **File** then **New**. Now click on the **DOWNLOAD** button (green arrow pointing from car). This will read the MAXIMIZER-II's configuration into the current open configuration on the PC.

2.5 Monitor and Data Logging

To monitor and/or data log requires that a PC is connected to the MAXIMIZER-II.



2.5.1 Monitoring

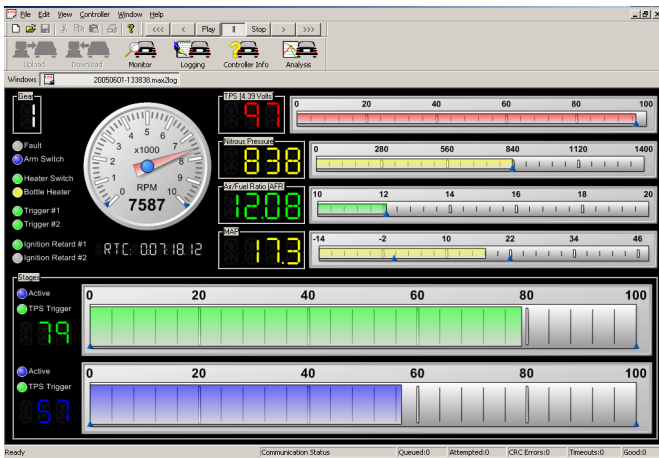

This screen graphically displays the operational status of the MAXIMIZER-II in real-time. To access this screen, simply click the Monitor button on the Main Screen or type M.

To exit this screen click on the X in the upper right hand corner of the screen, toggle the monitor button or type M.

2.5.2 Data Logging

To start logging click on the Logging button on the Main Screen or type L. You can data log with the Monitor screen open however it will reduce the number of data segments due to program overhead. For faster logging, close the monitor window.

To turn off logging, toggle the logging button or type L.

When logging is turned on, the automatically the PC creates a file using the following name format:

“MAXIMIZER-II II 20050514-113305.max2log”

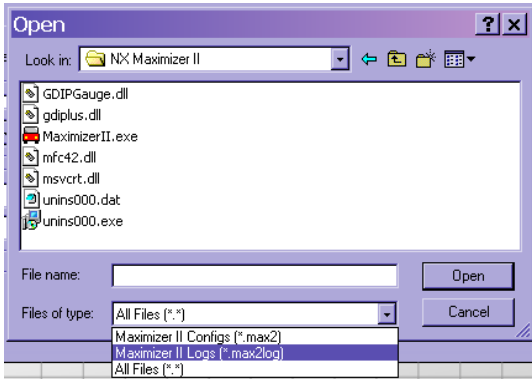

where 20050514 is the date yyyyymmdd and 113305 is a computer time stamp. The higher the number the more recent it is.

You can playback your log files by opening the file using the standard windows method. Click on **File** then **Open...**

In the Files of type section select MAXIMIZER-II II Logs. If the log files do not appear in your window, you may not be in the correct directory. To change directories click on the down arrow in the Look in section and select **Local Disk C:** then **Program Files** and then **NX MAXIMIZER-II II**

Once a log file is open, the monitor screen appears and the playback buttons at the top of the screen become accessible.

2.5.3 Data Analysis

This feature allows you to display data from a previously saved log file in a graphical format for advanced analysis. This is a very unique and powerful tool for tuning. The MAXIMIZER-II's ability to log data in the armed AND disarmed state together with the accuracy of the FJO Wideband AFR system and the Advanced Analysis package will allow you to monitor your nitrous jetting **as well as tune the fuel map of your engine** – even when the nitrous has **NOT** been activated.

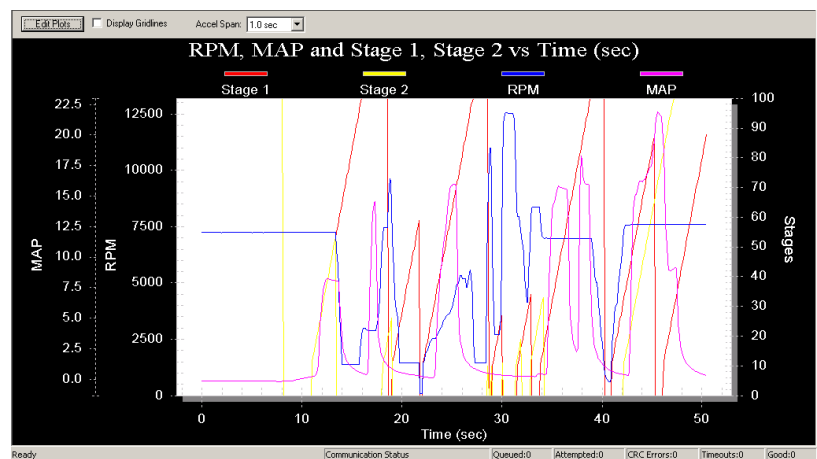

To begin, open the log file and then click the Analysis Plots button on the upper task bar.

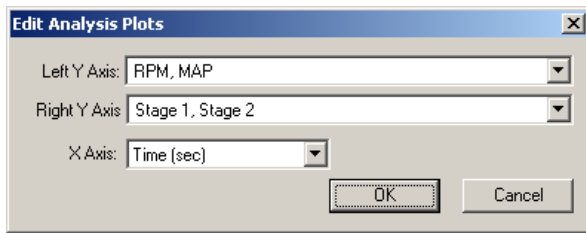

The X and Y-axis can be customized to display any combination of. This is done by selecting the items from the pull-down menus for each axis. For example, viewing EGO on the Y-axis and RPM on the X-axis will display your air-fuel ratio over your RPM range. The **acceleration plot** indicates how fast the RPM was increasing which can be used to compare performance from one run to the next as well as analyzing wheel spin or other conditions.

You can zoom in on any section of the graph by clicking and holding the left mouse button, and then dragging the cursor. A box will appear which indicates the area to be zoomed. To zoom out, click on the Unzoom button that appears in the upper right when you zoom in.

Additional features are available to customize the graph view as well as export the screen to a file or printer. This menu is selected by clicking the right mouse button while the cursor is over the graph. You can also customize your graph by double clicking on the open graph.

2.6 Software Updates

Free updates are available for the MAXIMIZER-II and related software at www.fjoracing.com

3. Accessories

Optional accessories available for the MAXIMIZER-II include:

- Nitrous Pressure Sensor
- FJO Wideband Air/Fuel Ratio controller (single or dual channel)
- AFR Gauge (digital)
- Nitrous Pressure Gauge (digital)
- Boost Gauge (digital)
- Status Gauge (digital)
- Automatic Bottle opener module
- Additional Solenoid driver module
- Datalogging module (available late 2005)

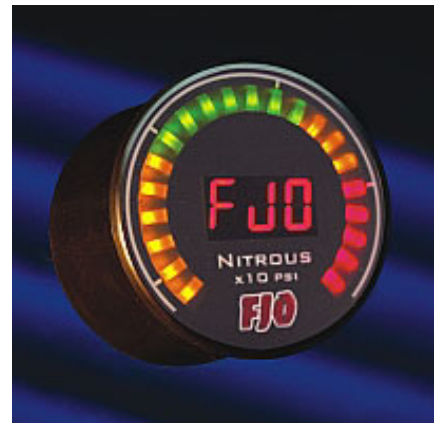

4. Disclaimer

FJO Racing Products may not be held responsible for any damages, how so ever caused, to any persons or equipment during the installation or operation of its' products. FJO's products are meant for off-road use only, and make no claims as to the units' ability to meet local safety or emissions laws.

5. Warranty

FJO Enterprises Inc. (FJO) warrants the material and workmanship of the equipment, components and parts manufactured by FJO against defects under normal use and service. This warranty shall extend for 180 days from the date of manufacture. Customers must return the defective part or component to the authorized distributor, Nitrous Express, shipping costs prepaid. Prior to returning a product for warranty inspection, the customer must first contact Nitrous Express with the product serial number to receive a WARRANTY CLAIM NUMBER. Units returned directly to FJO will be refused.

FJO may at its option, repair or replace without cost for parts and labour, the defective product. This warranty does not cover finishes, normal wear and tear, nor does it cover damage resulting from accident, misuse, dirt, tampering, unreasonable use, service attempted or performed by unauthorized service agencies, failure to provide reasonable maintenance, or FJO products that have been modified or used for commercial reasons.

FJO specifically does not warrant equipment, parts or components purchased by FJO or the customer from any third party manufacturers or suppliers. Rather, for any defect in respect of equipment, parts and components purchased from third party manufacturers and suppliers, the customer shall have recourse only to the terms of the warranty of that particular manufacturer or supplier. Any recommendations made by the third party manufacturer or suppliers concerning the use or application of their products are those of the manufacturer or supplier, and FJO extends no warranty with respect to the results obtained for their use. FJO does not warranty those products in any way beyond the term of the warranty extended by the manufacturer or supplier.

The warranty provided above, FJO's obligations and liabilities hereafter, and the rights and remedies of the customer are exclusive and in substitution for, and the customer waives all other warranties, guarantees, obligations, liabilities, rights and remedies, expressed or implied, arising by law or otherwise, including (without limitation) the implied warranties of merchantability or fitness of purpose, and any obligations or liability of FJO arising from tort, or loss of use, revenue or profit, or for incidental or consequential damage.

6. MAXIMIZER-II Wiring Diagrams

The following diagrams are provided as a reference only. If you are attempting to install the MAXIMIZER-II and require technical assistance, contact your dealer or FJO Technical support.

FJO Technical Assistance (204) 254-5623 ext 2

6.1 System

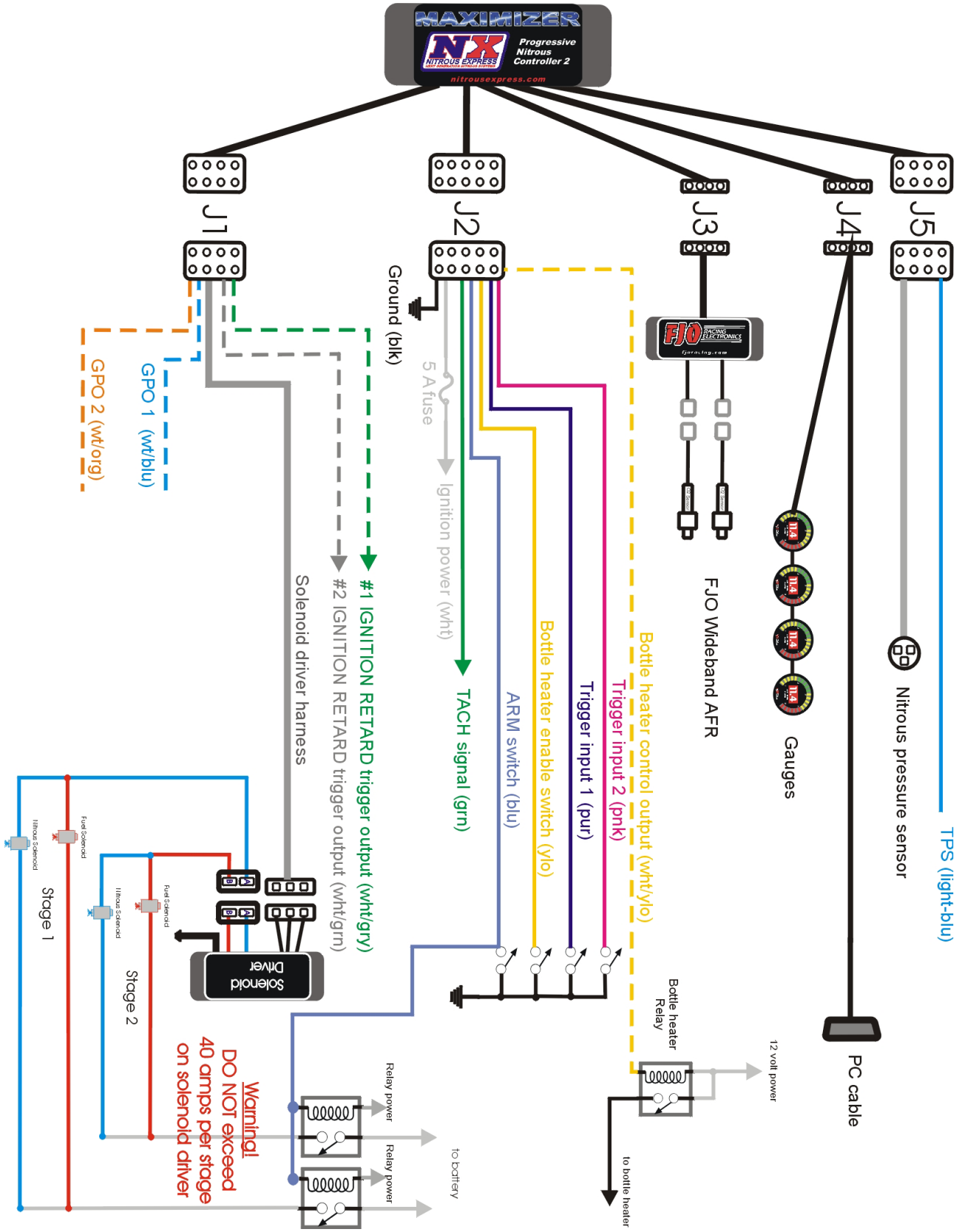

6.2 Status LED

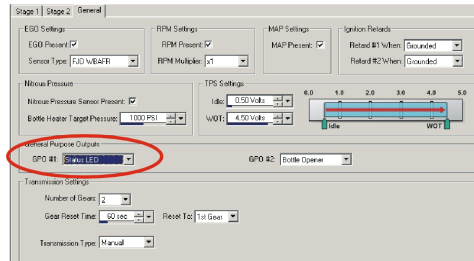
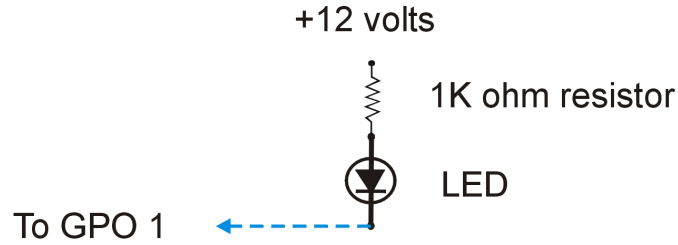

Note: LED and resistor included in kit

6.3 12 volt Arming Switch

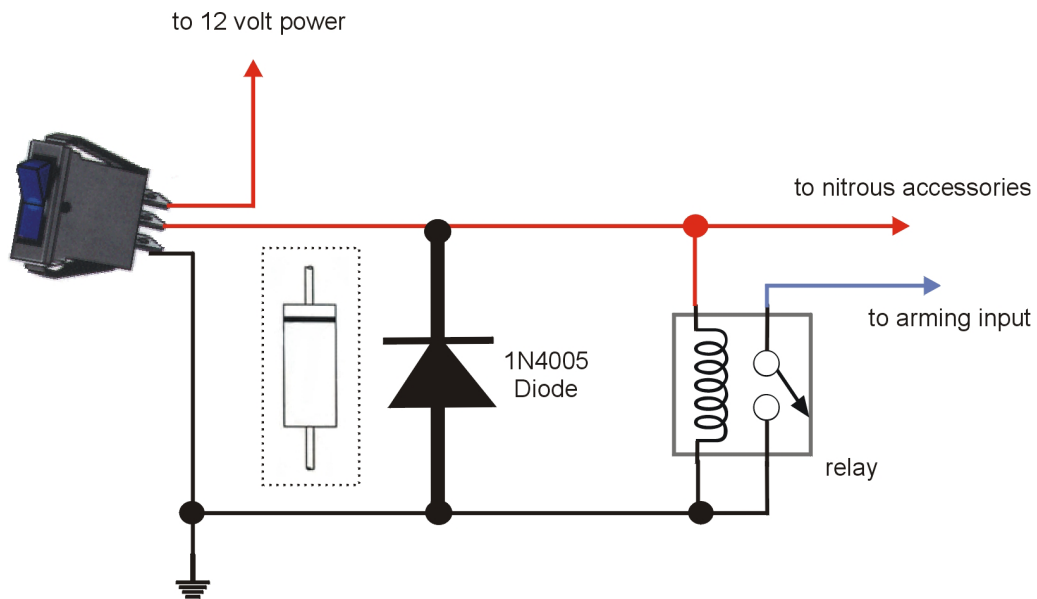

Note: Diode included in kit

6.4 Ignition Retard

for 12 volt active:

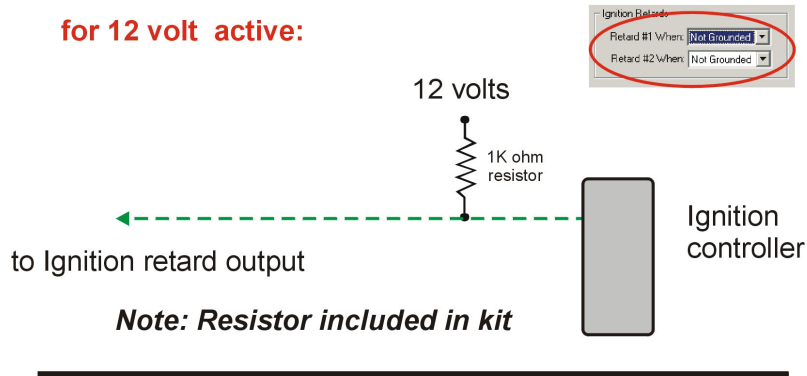

for 0 volt active:

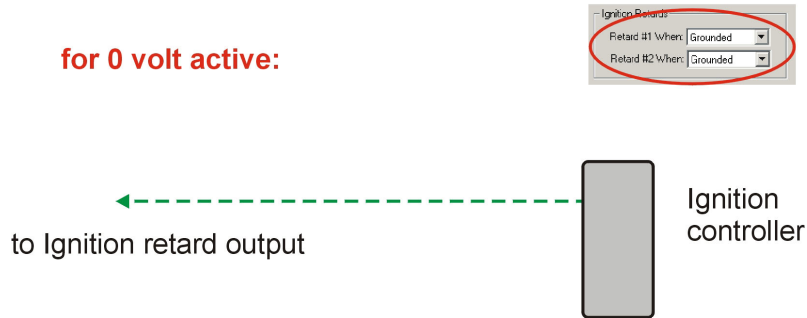

6.5 Remote Bottle Opener

to 12 volt power

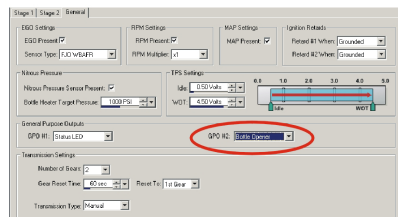
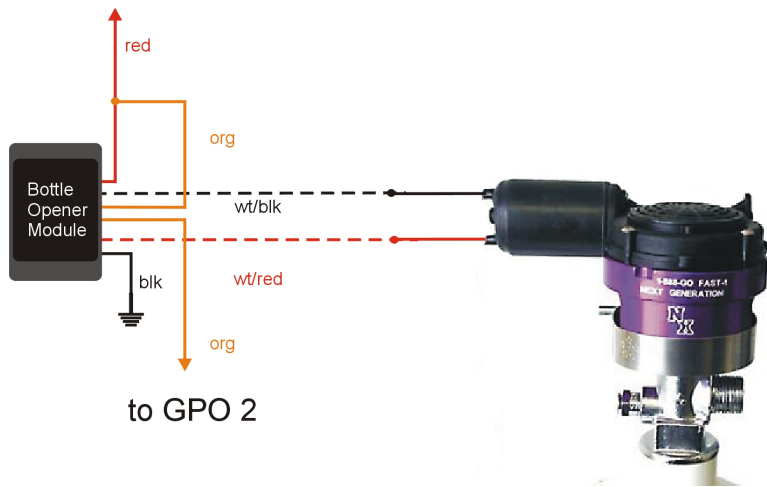

6.6 Automatic Purge

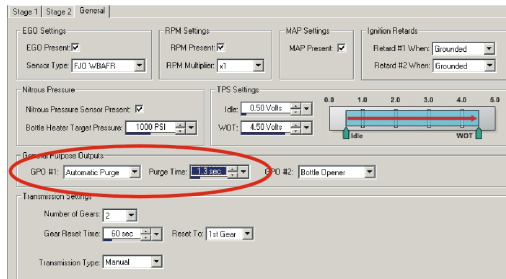
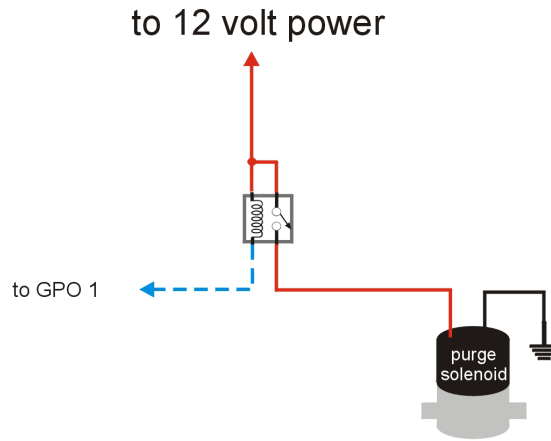

6.7 Fuel Pressure Safety Cut-off Switch

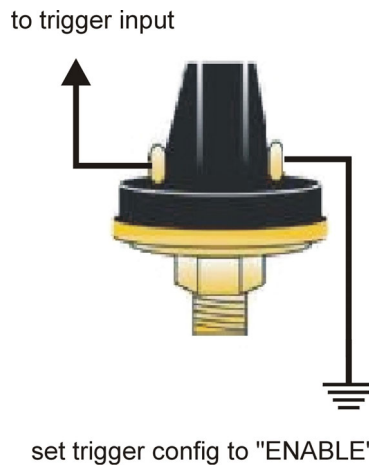

6.8 WOT Switch

Figure A illustrates how to connect a “HOT” wide-open-throttle switch. Set the WOT setting in the MAXIMIZER-II configuration to 4.5 volts, the TPS TRIGGER to 95%, and the IDLE to 0.5 volts.

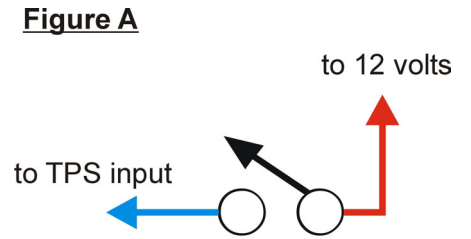
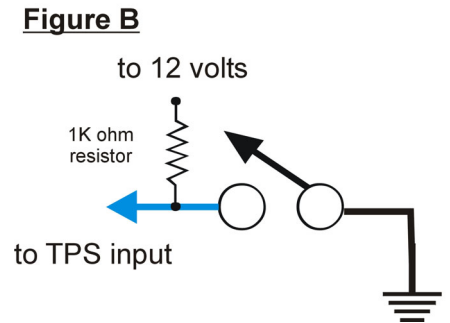

Figure B illustrates how to connect a “GROUND” wide-open-throttle switch. Set the WOT setting in the MAXIMIZER-II configuration to 0.5 volts, the TPS TRIGGER to 95%, and the IDLE to 4.5 volts.



Note: The 1K ohm resistor is included in the kit.

6.9 Narrowband O2 Sensor

