

Instruction Manual (Installation)



Multi-loop Module Type Temperature Controller
Enhanced Communication Module
(CC-Link)

Model : PUMCL

Fuji Electric Systems Co., Ltd.

INP-TN1PUMCL-E

Thank you for purchasing the Fuji module type temperature controller. Once you have confirmed that this is the product you ordered, please use it in accordance with the following instructions. For detailed information on operating this equipment, please refer to the separate user's manual. Please keep this Instruction Manual within easy reach of persons using this equipment

CAUTION

The contents of this manual are subject to change without notice. This manual is compiled with possible care for the purpose of accuracy, however, Fuji Electric Systems shall not be held liable for any damages, including indirect damage, caused by typographical errors, absence of information or use of information in this manual.

Confirming Specifications and Accessories

Before using the product, confirm that it matches the type ordered.
(For model code, please refer to page 4.)
Confirm that all of the following accessories are included.

Temperature Controller Enhanced Communication Module (CC-Link)	1 Unit
Instruction Manual	1 copy
Internal Communication Termination Resistance (100 Ω)	1 Unit

Related Information

Refer to "Module Type Temperature Controller Enhanced Communication Module (CC-Link) User's Manual" for details about the items described in this manual.

Content	Material name	Material No.
Specification	Catalog	ECNO 1162
Operating instruction	CC-Link Module User's Manual	INP-TN5A0200-E

Please Read First (Safety Warnings)

Please read this section thoroughly before using, and observe the mentioned safety warnings fully.

Safety warnings are categorized as "Warning" or "Caution".

⚠ Warning	Improper use of the equipment may result in death or serious injuries.
⚠ Caution	Improper use of the equipment may cause injury to the user or property damage.

1 ⚠ Warning

1-1 Installation and Wiring

- This equipment is intended to be used under the following conditions.

Ambient temperature	-10 to 50 degree C
Ambient humidity	90% RH or below (with no condensation)
Vibration	10 to 70Hz less than 9.8m/s ² (1G)
Warm-up time	30 min. or more
Installation category	IEC1010-1: class II
Pollution level	IEC1010-1: degree 2

- Note that the insulation class for this equipment is as follows. Before installing, please confirm that the insulation class for the equipment meets usage requirements.

Power	SLD/FG terminal (CC-Link connecting terminal)
Loader communication	CC-Link communication

==== Functional insulation (AC1000V) ——— Functional insulation (AC500V) Functional insulation (AC50V)

- In cases where damage or problems with this equipment may lead to serious accidents, install appropriate external protective circuits.
- To prevent damage and failure of the equipment, provide the rated power voltage.
- To prevent electric shock and equipment failure, do not turn the power ON until all wiring is complete.
- Before turning the power ON, confirm that clearance space has been secured to prevent shock or fire.
- Do not touch the terminal while the machine is ON. Doing so risks shock or equipment errors.
- Never disassemble, convert, modify or repair this equipment. Doing so risks abnormal operation, shock or fire.

1-2 Maintenance

- When installing or removing the equipment, turn the power OFF. Otherwise, shock, operational errors or failures may be caused.
- Periodic maintenance is recommended for continuous and safe use of this equipment.
- Some parts installed on this equipment have a limited life and/or may deteriorate with age.
- The warranty period for this unit (including accessories) is one year, if the product is used properly.

2 ⚠ Caution

2-1 Cautions when Installing

Please avoid installing in the following locations.

- Locations in which the ambient temperature falls outside the range of 0 to 50 degree C when equipment is in use.
- Locations in which the ambient humidity falls outside the range of 45 to 85% RH when equipment is in use.
- Locations with rapid temperature changes, leading to dew condensation.
- Locations with corrosive gases (especially sulfide gas, ammonia, etc.) or flammable gases.
- Locations with vibration or shock directly.
- Locations in contact with water, oil, chemicals, steam or hot water.
(If the equipment gets wet, there is a risk of electric shock or fire, so have it inspected by Fuji distributor.)
- Locations with high concentrations of atmospheric dust, salt or iron particles.
- Locations with large inductive interference, resulting in static electricity, magnetic fields or noise.
- Locations in direct sunlight.
- Locations that build up heat from radiant heat sources, etc.

2-2 Cautions when Attaching to DIN rails

- In case of mounting the temperature controllers to DIN rails, remember to push up the locking tabs to fasten the controllers onto DIN rail.
- To connect controllers, first release all locking tabs. Then, connect controllers and push up all locking tabs. Make sure that all locking tabs are fastened.
- Never fail to turn the power OFF, before detaching the terminal block or removing the main unit from the base part.
- In order to aid heat dissipation, do not block the top and the bottom of the equipment.
- When mounting / dismantling controllers to / from DIN rails, 30mm of clearance above and under the controllers should be provided.
- Do not use the terminal screws other than those supplied with this product.

2-3 Cautions for Wiring

- For wiring to terminal blocks, apply crimp terminals for M3 screw.
Screw size : M3 x 7 (with square washer)
Screw tightening torque : 0.78 N•m (8 kgf•cm)
- To avoid noise conductor effects, input signal wires should be separated from electric power lines or load lines.
- To comply with CE marking (EMC), we recommend to attach ferrite core to communication cable and power cable.

2-4 Error Operation

- The alarm function does not work properly when an error occurs unless the settings are made correctly. Always verify its setting before operation.

2-5 Others

- Please do not wipe the equipment with organic solvents such as alcohol or benzene, etc. If wiping is necessary, use a neutral cleaning agent.
- Do not use mobile phones near this equipment (within 50cm). Otherwise a malfunction may result.
- Malfunctions may occur if the equipment is used near a radio, TV, or wireless device.
- This equipment requires approx. 20 seconds before it starts to output.
- Before installing and wiring, take necessary measures for electrostatic discharge (ESD).

Part names and Functions

- Enhanced communication module controller

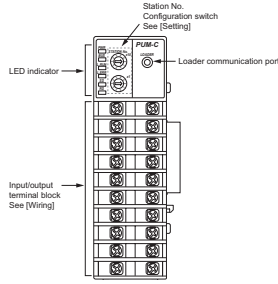

LED indicator

Three color LED lamps indicate the following operational conditions.

LED	Green	Red	Orange
PWR	(In priority order) OFF: Power is OFF Flash: In a (0.4-second) cycle: 1: Modules detected by initial polling: 0 2: After initial polling, an inter-module communication error occurs Flash: In a (0.1 second) cycle: Initial polling ON: Running	—	—
BUS	ON: Receiving by inter-module communication	—	ON: Transmitting by inter-module communication
L. RUN	ON: Data linking OFF: H/W resetting, or data linking not performed	—	—
L.ERR	—	ON: Communication error (CRC error, Station number setting error, communication speed setting error) OFF: Receiving normally, or while H/W resetting Flash: Setting switches during the power ON	—
SD	ON: Transmitting the CC-Link data	—	—
RD	ON: Receiving the CC-Link data	—	—

- Base part

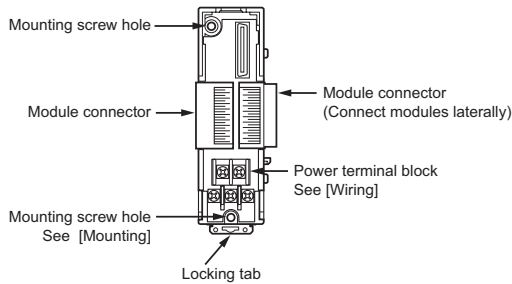

Setting

- Setting CC-Link Station No.

Station No. of CC-Link can be set using the Station No. configuration switch. Setting range is 1 to 61.
Apply a fine tip flat-head screwdriver to turn the Station No. configuration switch.

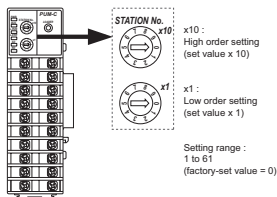

- CC-Link communication can not perform with the factory-set value (0). Make sure to set the Station No..
- When selected 0 or over 62, a Station No. selection error will occur and [L.ERR] LED will be ON.

- Setting CC-Link Communication speed.

Communication speed of CC-Link can be set using the station number configuration switch on the back of the controller.
Apply a fine tip flat-head screwdriver to turn the Station No. configuration switch.

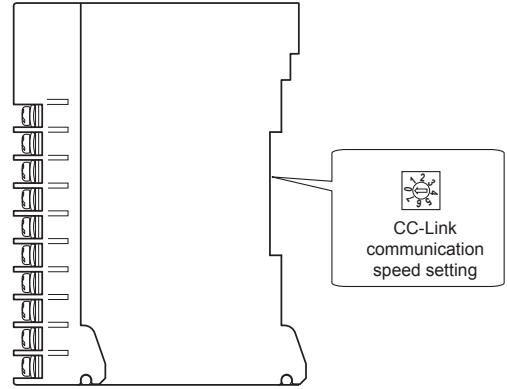

Communication speed and maximum transmission distance (when using Ver.1.10 compliant CC-Link special cable)

Communication speed setting	Communication speed	Max. transmission distance (Max. Network Length)
0	156kbps	1200m
1	625kbps	900m
2	2.5Mbps	400m
3	5Mbps	160m
4	10Mbps	100m

- When 5 to 9 are selected, a communication speed selection error will occur and [L.ERR] LED will be ON.

- Setting No. of stations occupied / Extended cyclic

No. of stations occupied/Extended cyclic can be set using the dip switch (SW1 to SW4) on the back of the controller.

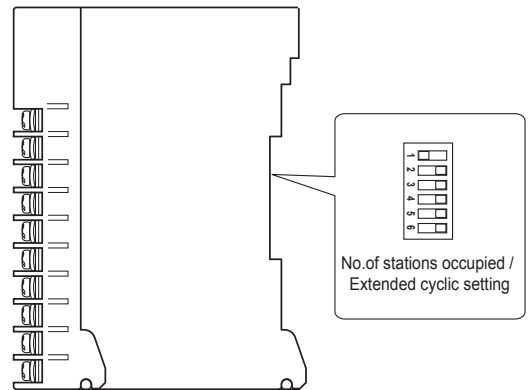

SW1	SW2	SW3	SW4	No. of stations occupied, Extended cyclic (No. of Ch)	Compliant Ver.
OFF	OFF	OFF	OFF	4 stations occupied x 1 (8Ch)	Ver. 1
ON	OFF	OFF	OFF	4 stations occupied x 1 (16Ch)	
OFF	ON	OFF	OFF	4 stations occupied x 2 (16Ch)	Ver. 2
ON	ON	OFF	OFF	4 stations occupied x 2 (32Ch)	
OFF	OFF	ON	OFF	4 stations occupied x 4 (32Ch)	
ON	OFF	ON	OFF	4 stations occupied x 4 (64Ch)	

- If the setting of the dip switch is other than those above, the actual setting will be "4 stations occupied x 1 (8Ch)"

Mounting

- Dimensions

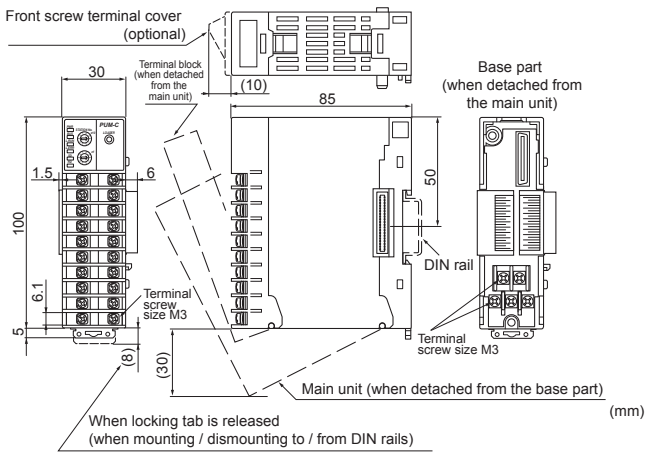

Cautions when mounting

In order to aid heat dissipation, 30mm of clearance (50mm recommended) above and under the controllers should be provided.

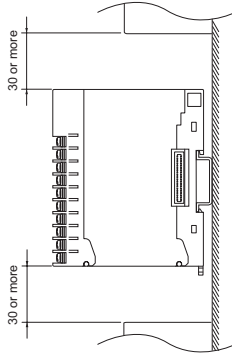

- Mounting to DIN rails

1. Pull down the locking tab of the base part. Hook the back of the controller onto the upper part of DiN rail.
2. Push the controller in the direction of arrow 2.

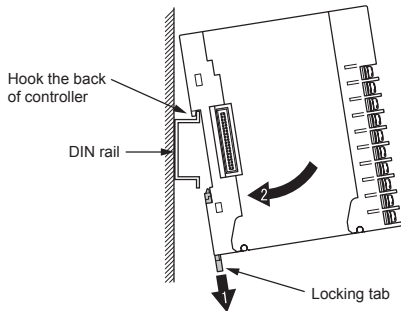

3. Push up the locking tab to fasten the controller to DIN rail.

- When connecting controllers after attaching to DIN rail, push up the locking tab after connecting controllers.

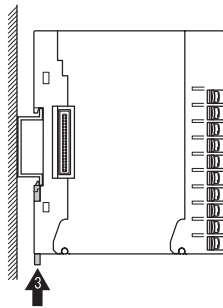

- Attaching end plates

When attaching controllers to DIN rails, we recommend to attach side connecting terminal covers (right and left 1set), then end plates (option) to the ends of the right most and left most controllers.

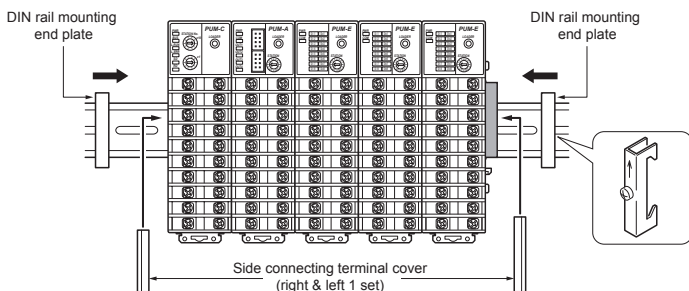

- Fixing with screws

When mounting controllers inside a cabinet with screws, connect the base parts of controllers first.

- Fixing screws are not included. Please prepare screws as required.

1. Refer to the figure below for the mounting screw hole size to decide the mounting position.

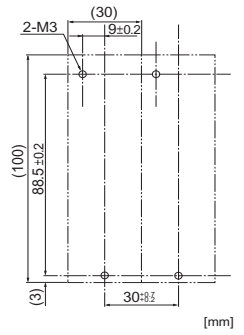

2. Remove the main units from the base part. See [How to detach the base part]
3. Connect base parts. Push up to fasten all the locking tabs.
4. Fixate the base parts onto the mounting position inside the cabinet with screws.
5. Attach the main units to the base parts.

- Connecting controllers

1. Check that locking tabs are pulled down (released).
2. Connect controllers with each other using side connectors.

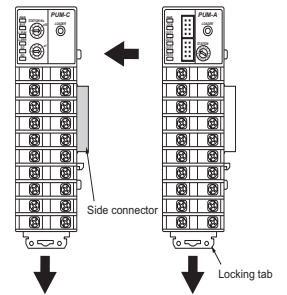

3. After mounting connected controllers onto DIN rail, make sure to push up all locking tabs. Controllers are fastened to DIN rail and to each other.
4. All connected controllers are connected to power supply via side connectors if one of controllers is directly connected to them.

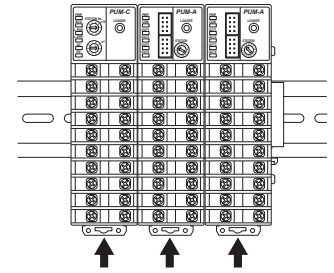

How to detach the base part

1. Press the lock lever on the top of the controller.
2. Pull down the upper part of main unit.
3. Detach the cutout on the lower end of back of the main unit from the projection on the base part.

- When attaching the main unit to the base part, take the reverse procedure to removing the main unit from the base part.
- Make sure that the lock lever of the main unit is fitted into the base part.

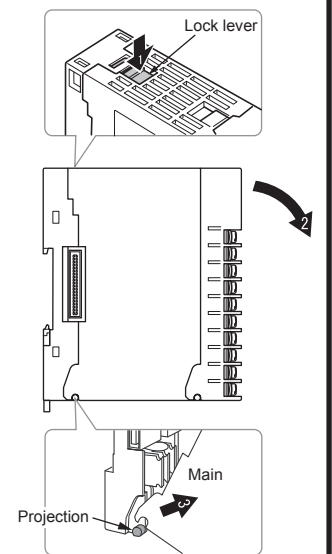

Wiring

- Front terminal block

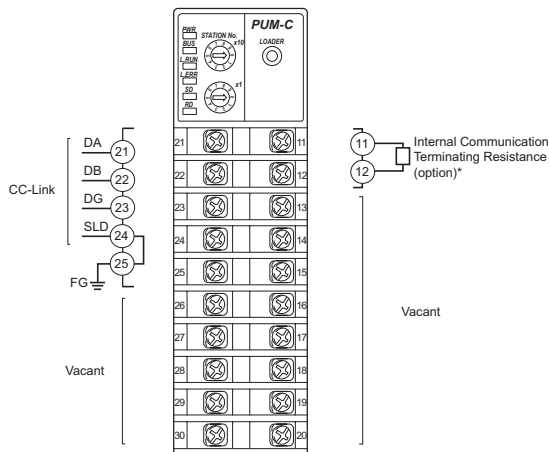

* This terminating resistance is different from the CC-Link terminating resistance (this is the terminating resistance for inter-module communication). Install the resistance (100Ω) supplied with this controller.

- Base part (power terminal)

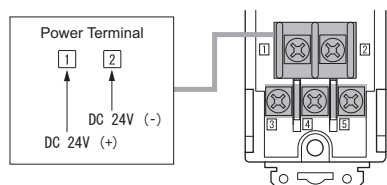

Note: The power cables more than one should not be connected.

Specification

General Specification

- Power Supply : DC24V±10%
- Power Consumption : Maximum 3.2W (135mA) [when DC24V is applied]
- Dimensions : 30 (W) × 100 (H) × 85 (D) mm (excluding the terminal cover and a projection)
- Weight : Approx. 200 g
- Installation method : Mounting on the wall or, install in the cabinet with the DIN rail with M3 screws
- Ambient temperature * : -10 to 50 degrees C
* "Ambient temperature" is the temperature underneath the controller inside equipment or the cabinet where the controller is installed.
- Ambient humidity : 90% RH or less (non condensing)
- Memory backup : Nonvolatile memory (EEPROM) backup
No. of updates : 100,000

Communication function

- Compliant version : CC-Link Ver.2.00 / 1.10
- Station type : Remote device station
- Communication speed and distance

Communication speed	156kbps	625kbps	2.5Mbps	5Mbps	10Mbps
Communication distance	1200m or less	900m or less	400m or less	200m or less	100m or less

* For more details, refer to "CC-Link Cable Wiring Manual" issued by CC-Link Partner Association.

- No. of stations occupied / Station No.: 4 stations / Settable Station No. 1 to 61
- Communication data length

No. of stations occupied / Extended cyclic	Remote input/output (RX/RX)	Remote register (RWr/RWw)	Control module (PUM-A) No. of connectable units
4 stations occupied x 1	128 bit each	16 words each	2 or 4 units
4 stations occupied x 2	256 bit each	32 words each	4 or 8 units
4 stations occupied x 4	512 bit each	64 words each	8 or 16 units

- Connecting cable : Ver.1.10 compliant CC-Link special cable
- Connecting method : M3 screw terminal block
- Terminating resistance : External (110 ohm, 1/2W)

Crimp terminal size

Please prepare power cables and crimp terminals of the size indicated below.

Power cable

Cable type	Size
Thermocouple (Compensation lead wire)	1.25mm ² or less
Power supply	1.25mm ² or less

Crimp terminal

Cable size	Screw tightening torque
0.25 to 1.25mm ²	0.8 N•m

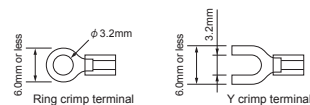

Model code

Enhanced communication module (CC-Link)

1	2	3	4	5	6	7	8	9	10	Contents	
P	U	M							0		Module type
											Advanced communication module
											Communication function
											CC-Link communication
											Instruction manual
										A	Japanese
										B	English

Accessories (Optional)

1	2	3	4	5	6	7	8	Contents	
P	U	M	Z	*					
					A	0	2		DIN rail mounting end plate
					A	0	3		Side connecting terminal cover (right & left 1 set)
					A	0	4		Front face screw terminal cover
					L	0	1		Loader connecting cable (RS-232C)

Fuji Electric Systems Co., Ltd.

Head Office
Gate City Osaki East Tower 11-2, Osaki 1-chome, Shinagawa-ku, Tokyo 141-0032, Japan
<http://www.fesys.co.jp/eng>