

Instructions - Parts List



MANUAL ELECTROSTATIC

PRO™ Xs2 Air Spray Gun

309291P

ENG

For use in Class I, Div. I hazardous locations using Group D spray materials.



For use in Group II, Zone 1 areas using Group IIA spray materials.



For Professional Use ONLY.



Important Safety Instructions:

Read all warnings and instructions in this manual.
Save these instructions.

See page for 2 **Table of Contents** and **List of Models**.

Part No. 244399, Series C

See page 2 for Model 244399 information.

100 psi (0.7 MPa, 7 bar) Maximum Air Inlet Pressure

100 psi (0.7 MPa, 7 bar) Maximum Working Fluid Pressure

US Patents 6758424 and 7,226,004

U.S. Patents 6758424 and 7,226,004

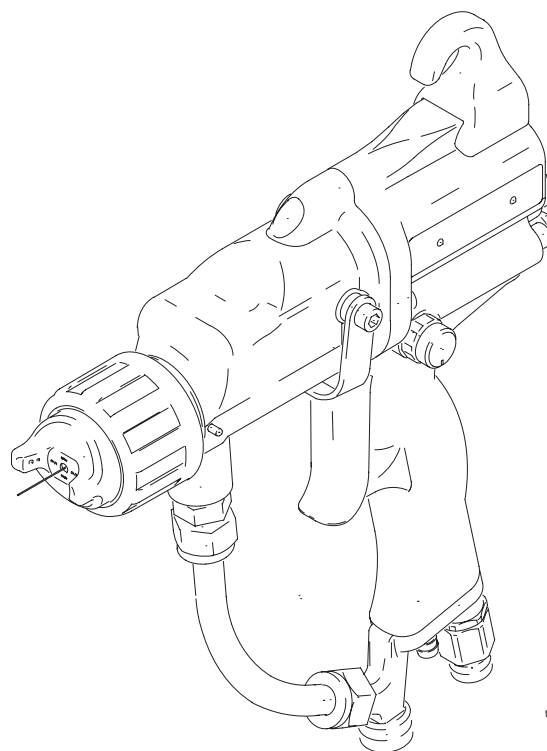

11295a



HO03

PROVEN QUALITY. LEADING TECHNOLOGY.

Table of Contents

Table of Contents	2	Repair	23
Model Information	2	Pressure Relief Procedure	23
Warnings	3	Prepare the Gun for Service	24
Introduction	5	Air Cap/Nozzle Replacement	25
How the Electrostatic Spray Gun Works	5	Electrode Replacement	26
Gun Overview	5	Fluid Packing Removal	27
Installation	6	Packing Rod Repair	28
Install the System	6	Barrel Removal	29
Warning Sign	6	Barrel Installation	29
Ventilate the Spray Booth	6	Power Supply Removal and Replacement	30
Connect the Air Line	8	Turbine Alternator Removal and Replacement	31
Connect the Exhaust Tube	8	Fan Air Adjustment Valve Repair	32
Select a Fluid Nozzle and Air Cap	9	Fluid Adjustment Valve Repair	33
Connect the Fluid Line	10	Air Valve Repair	33
Filter the Fluid	10	Atomizing Air Restrictor Valve Removal and Replacement	34
Grounding	11	ES ON/OFF Valve Repair	35
Check Electrical Grounding	12	Parts	36
Check Fluid Resistivity	13	Accessories	39
Check Fluid Viscosity	13	Air Line Accessories	39
Operation	14	Fluid Line Accessories	39
Maintenance	15	Gun Accessories	39
Flush the Spray Gun	15	Miscellaneous Accessories	40
Electrical Tests	17	Technical Data	41
Test Gun Resistance	17	Graco Standard Warranty	42
Test Power Supply Resistance	18	Graco Information	42
Test Electrode Resistance	19		
Troubleshooting	20		
Spray Pattern Troubleshooting	20		
Gun Operation Troubleshooting	21		
Electrical Troubleshooting	22		

Model Information

Part No.	Model	Type of Coatings		Operation Manual
		Standard	High Conductivity	
244399	PRO Xs2	X	X	309294/3W9294/3Z9294

Warnings

Warning Symbol





This symbol alerts you to the possibility of serious injury or death if you do not follow the instructions.

Caution Symbol



This symbol alerts you to the possibility of damage to or destruction of equipment if you do not follow the instructions.

 WARNING	
	<p>Fire, Explosion, and Electric Shock Hazard</p> <p>Flammable fumes, such as solvent and paint fumes, in work area can ignite or explode. To help prevent fire and explosion:</p> <ul style="list-style-type: none"> • Electrostatic equipment must be used only by trained, qualified personnel who understand the requirements of this manual. • Ground equipment, personnel, object being sprayed, and conductive objects in work area. See Grounding instructions. • Only use grounded Graco conductive air supply hoses. • Check gun and hose resistance and electrical grounding daily. • Use and clean equipment only in well ventilated area. • Interlock the gun air supply to prevent operation unless ventilating fans are on. • Use cleaning solvents with highest possible flash point when flushing or cleaning equipment. • Always turn the electrostatics off when flushing, cleaning or servicing equipment. • If there is static sparking or you feel a shock, stop operation immediately. Do not use equipment until you identify and correct the problem. • Eliminate all ignition sources; such as pilot lights, cigarettes, portable electric lamps, and plastic drop cloths (potential static arc). • Do not plug or unplug power cords or turn lights on or off when flammable fumes are present. • Keep work area free of debris, including solvent, rags and gasoline. • Keep a working fire extinguisher in the work area.
	<p>Toxic Fluid Hazard</p> <p>Hazardous fluids or toxic fumes can cause a serious injury or death if splashed in the eyes or on the skin, swallowed, or inhaled.</p> <ul style="list-style-type: none"> • Know the specific hazards of the fluid you are using. Read the fluid manufacturer's warnings. • Store hazardous fluid in an approved container. Dispose of the hazardous fluid according to all local, state, and national guidelines. • Wear appropriate protective clothing, gloves, eyewear, and respirator.

WARNING

Equipment Misuse Hazard

Equipment misuse can cause the equipment to rupture, malfunction, or start unexpectedly and result in a serious injury.

- This equipment is for professional use only.
- Read all manuals, tags, and labels before operating the equipment.
- Use the equipment only for its intended purpose. If you are uncertain, call your Graco distributor.
- Do not alter or modify equipment. Use only genuine Graco parts and accessories.
- Check the equipment daily. Repair or replace worn or damaged parts immediately.
- Do not exceed the maximum working pressure of the lowest rated system component. Maximum working air and fluid pressure of this equipment is 100 psi (0.7 MPa, 7.0 bar).
- Use fluids and solvents that are compatible with the equipment wetted parts. See the **Technical Data** section of all equipment manuals. Read the fluid and solvent manufacturer's warnings.
- Route the hoses away from traffic areas, sharp edges, moving parts, and hot surfaces. Do not expose Graco hoses to temperatures above 180°F (82°C) or below -40°F (-40°C).
- Do not kink or overbend hoses or use hoses to pull equipment.
- Wear hearing protection when operating this equipment.
- Comply with all applicable local, state, and national fire, electrical, and other safety regulations.

Pressurized Equipment Hazard

Spray from the gun, hose leaks, or ruptured components can splash fluid in the eyes or on the skin and cause serious injury.

- Do not point the spray gun at anyone or at any part of the body.
- Do not stop or deflect fluid leaks with your hand, body, glove, or rag.
- Follow the **Pressure Relief Procedure** on page 23 when you stop spraying and before cleaning, checking, or repairing equipment.
- Check hoses and couplings daily. Replace worn, damaged, or loose parts immediately.
- Tighten all fluid connections before each use.

Introduction

How the Electrostatic Spray Gun Works

The air hose supplies air to the spray gun. Part of the air operates the turbine and the rest of the air atomizes the fluid being sprayed. The turbine generates power, which is converted by the power cartridge to supply high voltage current to the gun's electrode.

The pump supplies fluid to the hose and gun, where the fluid is electrostatically charged as it passes the electrode. The charged fluid is attracted to the grounded workpiece, wrapping around and evenly coating all surfaces.

Gun Overview

The electrostatic gun includes the following controls (see FIG. 1).

- **FLUID adjustment valve.** Adjusts fluid rod travel. Use only in low flow conditions, to reduce wear.
- **Fan AIR adjustment valve.** Adjusts fan size and shape.

- **Atomizing air RESTRICTOR valve.** Restricts atomizing air flow. Replace with plug (included) if desired.
- **ES ON/OFF valve.** Turns electrostatics ON (I) or OFF (O).
- **ES INDICATOR.** Green when ES is ON (I).

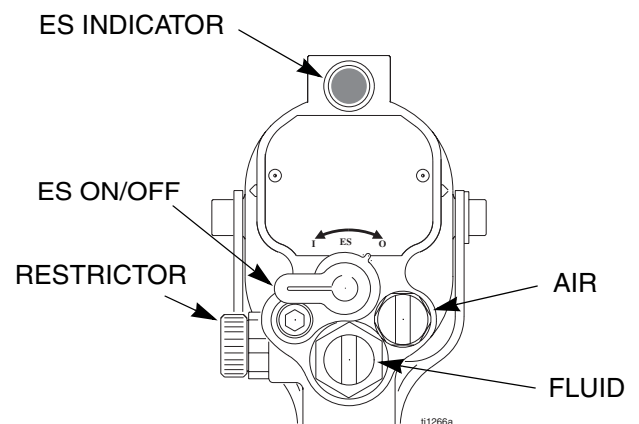



Fig. 1 Gun Overview

Installation

Install the System

 **WARNING**

Fire, Explosion, and Electric Shock Hazard

Installing and servicing this equipment requires access to parts which may cause electric shock or other serious injury if work is not performed properly.

- Do not install or service this equipment unless you are trained and qualified.
- Be sure your installation complies with National, State and Local codes for the installation of electrical apparatus in a Class I, Div. I, Group D or a Group II, Category 2G Hazardous Location.
- Comply with all applicable local, state, and national fire, electrical, and other safety regulations.

FIG. 2. shows a typical electrostatic air spray system. It is not an actual system design. For assistance in designing a system to suit your particular needs, contact your Graco distributor.

Warning Sign

Mount warning signs in the spray area where they can easily be seen and read by all operators. An English Warning Sign is provided with the gun.

Ventilate the Spray Booth

 **WARNING**

Flammable or Toxic Vapor Hazard

Provide fresh air ventilation to avoid the buildup of flammable or toxic vapors when spraying, flushing, or cleaning the gun. Do not operate the gun unless ventilation fans are operating.

Electrically interlock the gun air supply with the ventilators to prevent gun operation without ventilating fans operating. Check and follow all National, State, and Local codes regarding air exhaust velocity requirements.

High velocity air exhaust will decrease the operating efficiency of the electrostatic system. Air exhaust velocity of 100 ft/min (31 linear meters/minute) should be sufficient.

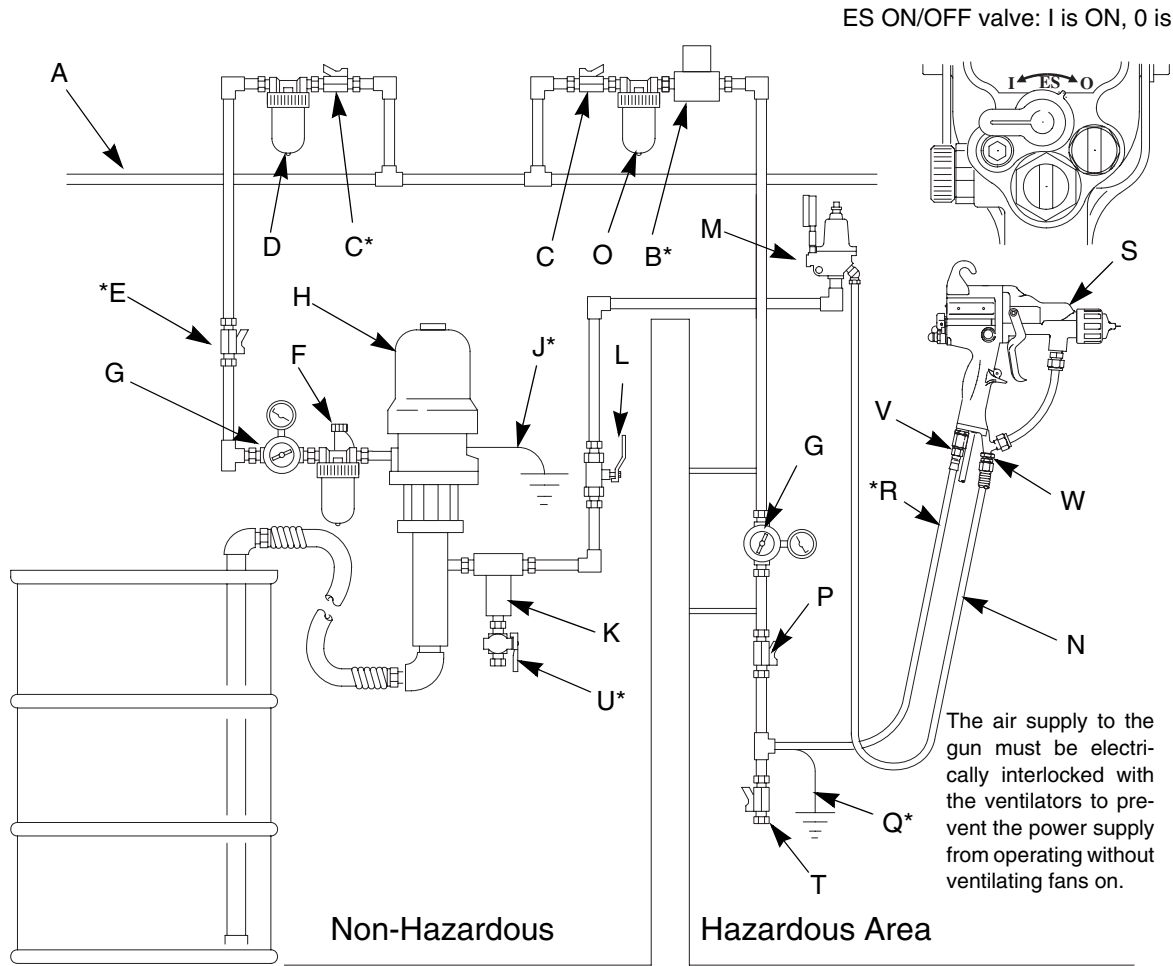

TI1531a

Fig. 2. Typical Installation Key

- | | | | |
|----|--|----|---|
| A | Main Air Supply Line | N | Fluid Supply Line |
| B* | Ventilation Fan Interlock Solenoid Valve | O | Gun Air Line Filter/Water Separator |
| C* | Main Air Supply Shutoff Valve (bleed-type) | P | Gun Air Supply Line Shutoff Valve |
| D | Pump Air Line Filter/Water Separator | Q* | Air Hose Ground Wire |
| E* | Pump Air Supply Shutoff Valve (bleed-type) | R* | Graco Grounded Air Hose |
| F | Air Line Lubricator | S | Electrostatic Air Spray Gun |
| G | Air Pressure Regulator | T | Air Line Drain Valve |
| H | Pump | U* | Fluid Drain Valve |
| J* | Pump Ground Wire | V | Gun Air Inlet |
| K | Fluid Filter | W | Gun Fluid Inlet |
| L | Fluid Supply Line Shutoff Valve | * | Required for safe operation. Must be purchased separately. NOTE: Solenoid valve (B) is not offered as a Graco accessory. |
| M | Fluid Pressure Regulator | | |

Connect the Air Line

WARNING

Electric Shock Hazard



To reduce the risk of electric shock or other serious injury, the air supply hose must be electrically connected to a true earth ground. **Use only Graco Grounded Air Supply Hose.**

1. Connect the Graco Grounded Air Supply Hose (R) between the air supply line and the gun's air inlet (V). The gun air inlet fitting has a left-hand thread. Connect the air supply hose ground wire (Q) to a true earth ground.
2. Install an air line filter/water separator (O) on the gun air line to ensure a dry, clean air supply to the gun. Dirt and moisture can ruin the appearance of your finished workpiece and can cause the gun to malfunction.
3. Install a bleed-type air regulator (G) on the pump and gun air supply lines to control air pressure to the pump and gun.

4. Install a bleed-type air valve (E) on the pump air line to shut off air to the pump. Install an additional bleed-type air valve (C) on the main air line (A) to isolate the accessories for servicing.

WARNING

Pressurized Equipment Hazard



The bleed-type air valve (E) is required in your system to relieve air trapped between the valve and the pump after the air regulator is shut off. Trapped air can cause the pump to cycle unexpectedly, which can result in serious injury, including splashing fluid in the eyes or on the skin.

5. Install an air shutoff valve (P) on each gun air supply line to shut off air to the gun(s).

Connect the Exhaust Tube

Press the exhaust tube (38) onto the barbed adapter on the bottom of the gun handle. Secure the tube with the clamp (39).

Select a Fluid Nozzle and Air Cap

WARNING

Pressurized Equipment Hazard

To reduce the risk of an injury, follow the  **Pressure Relief Procedure** on page 23 before removing or installing a fluid nozzle and/or air cap.

The gun is supplied with Part No. 197266 Nozzle and 24A376 Air Cap. If you require a different size, refer to Table 1 and Table 2, and instruction manual 309419, or consult with your Graco distributor. See **Air Cap/Nozzle Replacement** on page 25.

A wide pattern kit (P/N 24A431) is included with the gun and if installed, will provide more fan air for wider spray patterns. (If pattern becomes split, use the fan air valve to reduce the amount of fan air.)

Table 1: Fluid Nozzles

Part No.	Orifice Size
197263	0.75 mm (.030 in.)
197264	1.0 mm (.042 in.)
197265	1.2 mm (.047 in.)
197266	1.5 mm (.055 in.)
197267	1.8 mm (.070 in.)
197268†	2.0 mm (.080 in.)
249920*	0.75 mm (.030 in.)
249921*	1.0 mm (.042 in.)
249922*	1.2 mm (.047 in.)
249923*	1.5 mm (.055 in.)
249924*	1.8 mm (.070 in.)
249925*†	2.0 mm (.080 in.)

* Glass-reinforced acetal construction.

† Air cap 24A439 must be used with a 2.0 mm (0.80 in.) nozzle.

Table 2: Air Caps

Part No.	Pattern Shape and Length in. (mm)	Recommended Fluids and Production Rates
24A438	Round end; 15-17 (381-432)	Light to medium viscosity. Up to 15 oz/min (450 cc/min)
24A279	Round end; 14-16 (356-406)	Medium to high viscosity and high solids. Up to 15 oz/min (450 cc/min)
24A376*	Tapered end; 17-19 (432-483)	Light to medium viscosity. Up to 15 oz/min (450 cc/min)
24A274	Tapered end; 12-14 (305-356)	Light to medium viscosity. Up to 15 oz/min (450 cc/min)
24A439	Round end; 11-13 (279-330)	Medium to high viscosity and high solids. Up to 15 oz/min (450 cc/min) For use with 2.0 mm nozzle.
24A275	Tapered end; 14-16 (356-406)	Light to medium viscosity and high solids. Aerospace coatings. Up to 25 oz/min (750 cc/min).

* Also available in the following colors:

- 24A276 - blue
- 24A277 - red
- 24A278 - green

Connect the Fluid Line

1. Before connecting the fluid line (N), blow it out with air and flush it with solvent. Use solvent which is compatible with the fluid to be sprayed.
2. Install a fluid regulator (M) on the fluid line to control fluid pressure to the gun.
3. Install a fluid filter (K) and drain valve (U) at the pump outlet.

4. Connect the fluid line to the 3/8 npsm gun fluid inlet (W).
5. Before running any paint through the spray gun, flush it out with a compatible solvent.

Filter the Fluid

Install a fluid filter (K) to remove particles and sediment which could clog the spray nozzle.

WARNING

Pressurized Equipment Hazard





The fluid drain valve (U) is required in your system to assist in relieving fluid pressure in the displacement pump, hose, and gun. Triggering the gun to relieve pressure may not be sufficient. Install a drain valve close to the pump's fluid outlet. The drain valve reduces the risk of serious injury, including splashing in the eyes or on the skin.

Grounding

WARNING

Fire, Explosion, and Electric Shock Hazard

When operating the electrostatic gun, any ungrounded objects in the spray area (people, containers, tools, etc.) can become electrically charged. Improper grounding can result in static sparking, which can cause a fire, explosion, or electric shock. Follow the grounding instructions below.

The following are minimum grounding requirements for a basic electrostatic system. Your system may include other equipment or objects which must be grounded. Check your local electrical code for detailed grounding instructions. Your system must be connected to a true earth ground.

- *Pump:* ground the pump by connecting a ground wire and clamp as described in your separate pump instruction manual.

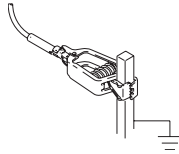

- *Electrostatic Air Spray Gun:* ground the gun by connecting the Graco Grounded Air Hose and connecting the air hose ground wire to a true earth ground. See **Check Electrical Grounding**, page 12.

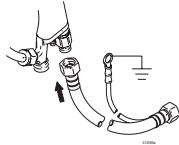

- *Air compressors:* ground the equipment according to the manufacturer's recommendations.
- *All air and fluid lines* must be properly grounded. Use only grounded hoses with a maximum of 100 feet (30.5 m) combined hose length to ensure grounding continuity.

- *All persons entering the spray area:* shoes must have conductive soles, such as leather, or personal grounding straps must be worn. Do not wear shoes with non-conductive soles such as rubber or plastic. If gloves are necessary, wear the conductive gloves that are supplied with the gun. If non-Graco gloves are worn, cut off fingers or palm area of glove, to ensure your hand contacts the grounded gun handle.



- *Object being sprayed:* keep the workpiece hangers clean and grounded at all times. Resistance must not exceed 1 megohm.

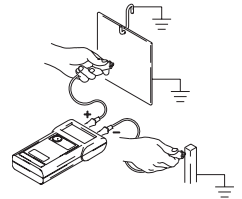

- *The floor of the spray area:* must be electrically conductive and grounded. Do not cover the floor with cardboard or any non-conductive material which would interrupt grounding continuity.

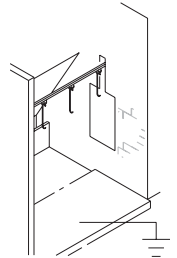

- *Flammable liquids in the spray area:* must be kept in approved, grounded containers. Do not use plastic containers. Do not store more than the quantity needed for one shift.

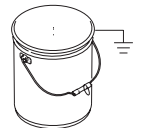

- *All electrically conductive objects or devices in the spray area:* including fluid containers and wash cans, must be properly grounded.

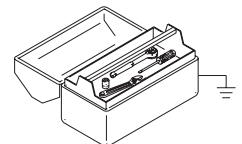

Check Electrical Grounding

! WARNING

Fire, Explosion, and Electric Shock Hazard



Megohmmeter Part No. 241079 (AA-see FIG. 3.) is not approved for use in a hazardous area. To reduce the risk of sparking, do not use the megohmmeter to check electrical grounding unless:

- The gun has been removed from the hazardous area;
- Or all spraying devices in the hazardous area are turned off, ventilation fans in the hazardous area are operating, and there are no flammable vapors in the area (such as open solvent containers or fumes from spraying).

Failure to follow this warning could cause fire, explosion, and electric shock and result in serious injury and property damage.

1. Have a qualified electrician check the electrical grounding continuity of the spray gun and air hose.

2. Turn the ES ON/OFF valve OFF.

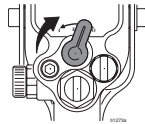

3. Turn off the air and fluid supply to the gun. The fluid hose must not have any fluid in it.

4. Make sure the grounded air hose (R) is connected and the hose ground wire is connected to a true earth ground.

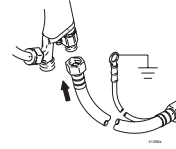

5. Measure the resistance between the gun handle (BB) and a true earth ground (CC). Use an applied voltage of 500 minimum to 1000 volts maximum. The resistance should not exceed 1 megohm. See FIG. 3..

6. If the resistance is greater than 1 megohm, check the tightness of the ground connections and be sure the air hose ground wire is connected to a true earth ground. If the resistance is still too high, replace the air hose.

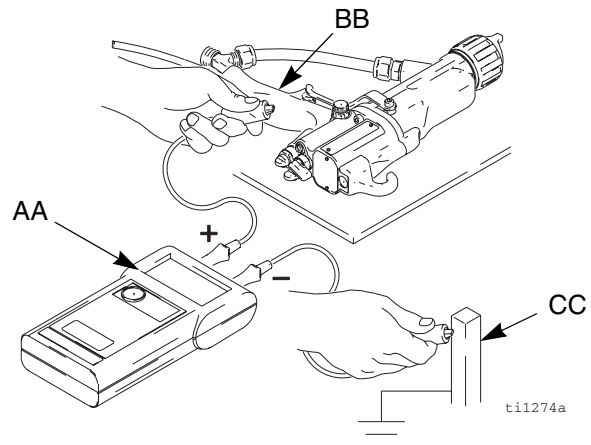





Fig. 3. Check Gun Grounding

Check Fluid Resistivity

WARNING

Fire, Explosion, and Electric Shock Hazard

 Check the fluid resistivity in a non-hazardous area only. Resistance Meter 722886 and Probe 722860 are not approved for use in a hazardous area.

 Failure to follow this warning could cause fire, explosion, or electric shock and result in serious injury and property damage.



Graco Part No. 722886 Resistance Meter and 722860 Probe are available as accessories to check that the resistivity of the fluid being sprayed meets the requirements of an electrostatic air spray system.

Follow the instructions included with the meter and probe. Readings of 25 megohms-cm and above provide the best electrostatic results.

Check Fluid Viscosity

To check fluid viscosity you will need:

- a viscosity cup
 - a stopwatch.
1. Completely submerge the viscosity cup in the fluid. Lift the cup out quickly, starting the stopwatch as soon as the cup is completely removed.
 2. Watch the stream of fluid coming from the bottom of the cup. As soon as there is a break in the stream, shut off the stopwatch.
 3. Record the fluid type, elapsed time, and size of the viscosity cup.
 4. If the viscosity is too high or too low, contact the material supplier. Adjust as necessary.

Operation



INSTRUCTIONS

Refer to the gun operation manual (supplied) for Setup, Shutdown, and Daily Care procedures.

Maintenance



INSTRUCTIONS

Refer to the gun operation manual (supplied) for Daily Care and Cleaning procedures.

Flush the Spray Gun

Flush the gun before changing colors, at the end of the day, before storing, and before repairing the gun.

! WARNING

Fire, Explosion, and Electric Shock Hazard



To reduce the risk of fire, explosion, or electric shock, turn the ES ON/OFF valve OFF before flushing the gun.



! CAUTION

Flush the gun with a non-conductive, compatible solvent. Conductive solvents can cause the gun to malfunction.

Do not use methylene chloride as a flushing or cleaning solvent with this gun as it will damage nylon components.

1. Turn the ES ON/OFF valve OFF.

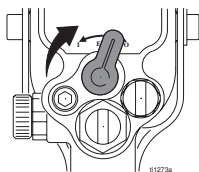

! WARNING

Pressurized Equipment Hazard



To reduce the risk of an injury, follow the **Pressure Relief Procedure** on page 23 whenever you are instructed to relieve the pressure.

2. Relieve the pressure.

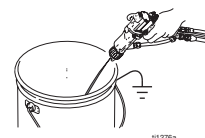

3. Change the fluid source to solvent, or disconnect the fluid line and connect a solvent supply line to the gun.

4. Point the gun into a grounded metal pail. Flush until clean solvent flows from the gun.

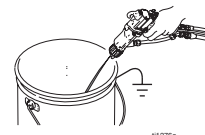

5. Relieve the pressure.

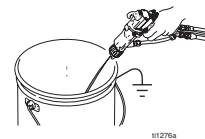

Maintenance

6. Shut off or disconnect the solvent line.
7. Hang the gun from its hook, with the nozzle pointing down.
8. When ready to spray again, reconnect the fluid supply line. Follow the Setup procedure in the Operation Manual.

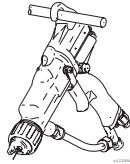

Electrical Tests

Electrical components inside the gun affect performance and safety. The following procedures test the condition of the power supply (18) and electrode (29), and electrical continuity between components.

Use megohmmeter Part No. 241079 (AA) and an applied voltage of 500 V. Connect the leads as shown.

WARNING

Fire, Explosion, and Electric Shock Hazard



Megohmmeter Part No. 241079 (AA-see FIG. 4.) is not approved for use in a hazardous area. To reduce the risk of sparking, do not use the megohmmeter to check electrical grounding unless:

- The gun has been removed from the hazardous area;
- Or all spraying devices in the hazardous area are turned off, ventilation fans in the hazardous area are operating, and there are no flammable vapors in the area (such as open solvent containers or fumes from spraying).

Failure to follow this warning could cause fire, explosion, and electric shock and result in serious injury and property damage.

Test Gun Resistance

1. Flush and dry the fluid passage.
2. Measure resistance between the electrode needle tip (29) and the air swivel (35); it should be 101-121 megohms. If outside this range, go to the next test. If in range, refer to **Electrical Troubleshooting** on page 22, for other possible causes of poor performance.

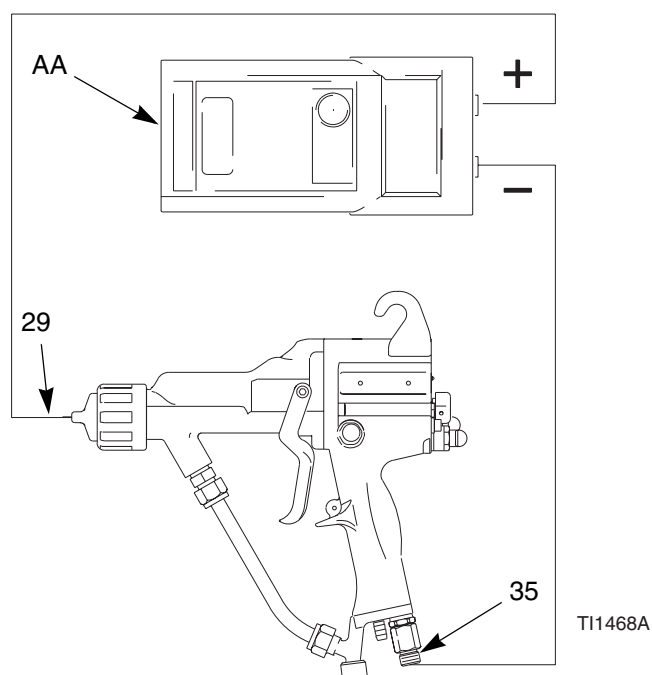

Fig. 4. Test Gun Resistance

Test Power Supply Resistance

1. Remove the power supply (18), page 29.
2. Remove the turbine alternator (19) from the power supply, page 30.
3. Measure resistance from the power supply's ground strips (EE) to the spring (18b). See FIG. 5..
4. The resistance should be 75-85 megohms. If outside this range, replace the power supply. If in range, proceed to the next test.
5. If you still have problems, refer to **Electrical Troubleshooting** on page 22 for other possible causes of poor performance, or contact your Graco distributor.
6. Be sure the spring (18b) is in place before reinstalling the power supply.

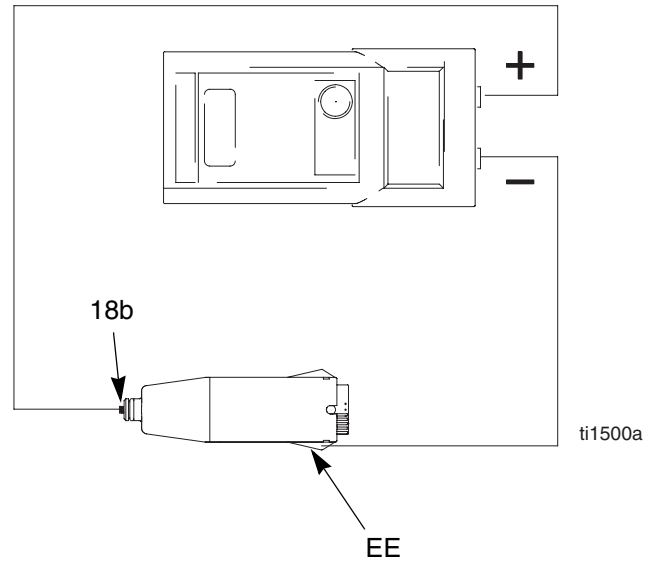

Fig. 5. Test Power Supply Resistance

Test Electrode Resistance

1. Insert a conductive rod (B) into the gun barrel (removed for the power supply test) and against the metal contact (C) in the front of the barrel.
2. Measure the resistance between the conductive rod (B) and the electrode (29). The resistance should be 20-30 megohms. See FIG. 6..
3. If in range, refer to **Electrical Troubleshooting** on page 22 for other possible causes of poor performance, or contact your Graco distributor.
4. Remove the electrode (29), page 26. Measure the resistance between the contact (E) and the electrode wire (F). The resistance should be 20-30 megohms. If out of range, replace the electrode. See FIG. 7..
5. Make sure the metal contact (C) in the barrel, the nozzle contact ring (7a, FIG. 8.), and the electrode contact (E) are clean and undamaged.

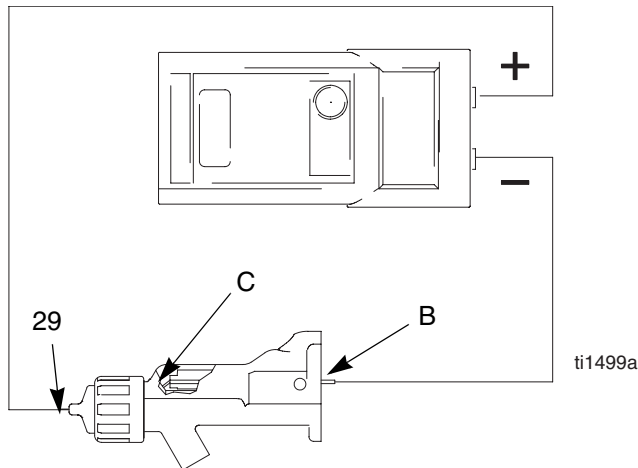

Fig. 6. Test Electrode Resistance

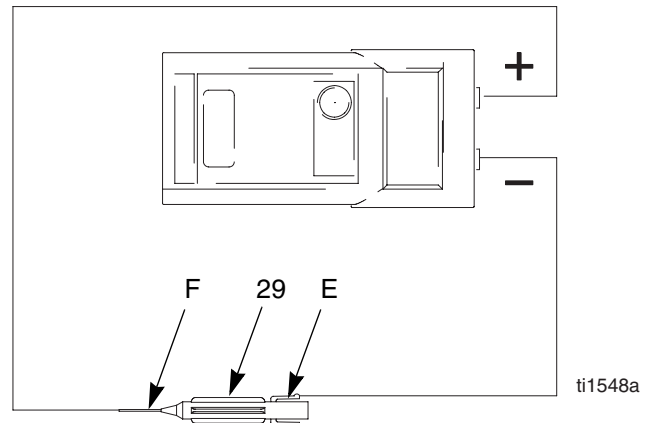

Fig. 7. Electrode

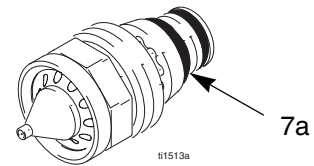



Fig. 8. Nozzle Conductive O-Ring

Troubleshooting

! WARNING

Electric Shock Hazard



Installing and servicing this equipment requires access to parts which may cause an electric shock or other serious injury if the work is not performed properly. Do not install or repair this equipment unless you are trained and qualified.

! WARNING

Pressurized Equipment Hazard





To reduce the risk of an injury, follow the **Pressure Relief Procedure** on page 23 whenever you are instructed to relieve the pressure.

Check all possible remedies in the Troubleshooting Chart before disassembling the gun.

Spray Pattern Troubleshooting

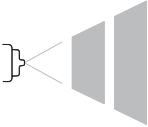
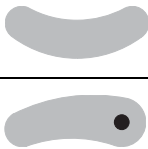
Some spray pattern problems are caused by the improper balance between air and fluid.

Problem	Cause	Solution
Fluttering or spitting spray. 	No fluid.	Refill supply.
	Loose, dirty, damaged nozzle/seat.	Clean or replace nozzle, page 25.
	Air in fluid supply.	Check fluid source. Refill.
Improper spray pattern.	Damaged nozzle or air cap.	Replace, page 25.
	Fluid buildup on air cap or nozzle.	Clean. See Operation Manual.
	Fan air pressure too high.	Decrease.
	Fluid too thin.	Increase viscosity.
	Fluid pressure too low.	Increase.
	Fan air pressure too low.	Increase.
	Fluid too thick.	Reduce viscosity.
Streaks.	Too much fluid.	Decrease flow.
	Did not apply 50% overlap.	Overlap strokes 50%.
	Dirty or damaged air cap.	Clean or replace, page 25.

Gun Operation Troubleshooting

Problem	Cause	Solution
Excessive spray fog.	Atomizing air pressure too high.	Close restrictor valve some, or decrease air pressure as low as possible; minimum 40 psi (0.28 MPa, 2.8 bar) needed at gun for full voltage.
	Fluid too thin.	Increase viscosity.
"Orange Peel" finish.	Atomizing air pressure too low.	Open atomizing air valve more or increase gun air inlet pressure; use lowest air pressure necessary.
	Poorly mixed or filtered fluid.	Remix or refilter fluid.
	Fluid too thick.	Reduce viscosity.
Fluid leaks from the fluid packing area	Worn packings or rod.	Replace packings or rod; see page 28.
Air leaks from the front of the gun	Air valve (21) is not seating properly.	Clean and service air valve; see page 33.
Fluid leakage from the front of the gun	Worn or damaged packing rod (26).	Replace; see page 28
	Worn fluid seat.	Replace fluid nozzle and/or electrode needle; see pages 25 to 26.
	Loose fluid nozzle (7).	Tighten; see page 25.
	Damaged nozzle o-ring (7b).	Replace; see page 25.
Gun does not spray	Low fluid supply.	Add fluid if necessary.
	Damaged air cap (9).	Replace; see page 25.
	Dirty or clogged fluid nozzle (7).	Clean; see page 25.
	Damaged fluid nozzle (7).	Replace; see page 25.
	Damaged fluid adjustment valve (25).	Replace; see page 33.
Dirty air cap	Misaligned air cap (9) and fluid nozzle (7).	Clean fluid buildup off air cap and fluid nozzle seat; see page 25.

Electrical Troubleshooting

Problem	Cause	Solution
Poor wrap.	ES ON/OFF valve OFF (0).*	Turn ON (I).
	Gun air pressure too low.	Check air pressure to gun; minimum 40 psi (0.28 MPa, 2.8 bar) needed at gun for full voltage.
	Atomizing air pressure too high.	Decrease.
	Fluid pressure too high.	Decrease.
	Incorrect distance from gun to part.	Should be 8-12 in. (200-300 mm).
	Poorly grounded parts.	Resistance must be 1 megohm or less. Clean workpiece hangers.
	Faulty gun resistance.	See Test Gun Resistance on page 17.
	Low fluid resistivity.	Check fluid resistivity, page 13.
	Fluid leaks from the packing (26d) and causes a short.	Clean the packing rod cavity. Replace the packing rod. See page 28.
ES indicator or voltage/current display is not lit.	ES ON/OFF valve OFF (0).*	Turn ON (I).
	No power.	Replace power supply. See page 30.
Operator gets mild shock.	Operator not grounded or is near ungrounded object.	See Grounding on page 11.
	Gun not grounded.	See Check Electrical Grounding on page 12 and Test Gun Resistance on page 17.
Operator gets shock from workpiece.	Workpiece not grounded.	Resistance must be 1 megohm or less. Clean workpiece hangers.

* ES indicator light is off when the gun is triggered.

Repair

Pressure Relief Procedure



WARNING

Pressurized Equipment Hazard

The system pressure must be manually relieved to prevent the system from starting or spraying accidentally. To reduce the risk of an injury from electric shock, accidental spray from the gun, splashing fluid, or moving parts, follow the **Pressure Relief Procedure** whenever you:

- are instructed to relieve the pressure
- stop spraying
- check or service any of the system equipment
- or install or clean the fluid nozzle.

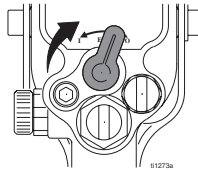
1. Turn the ES ON/OFF valve OFF.



2. Turn off the air bleed valves to the fluid source and to the gun.

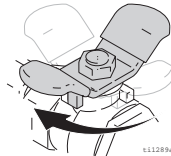

3. Trigger the gun into a grounded metal waste container to relieve the fluid pressure.

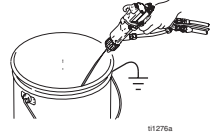

4. Open the pump drain valve, having a waste container ready to catch the drainage. Leave the pump drain valve open until you are ready to spray again.

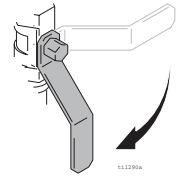

5. If the nozzle or hose is completely clogged or pressure is not fully relieved, slowly loosen the hose end coupling. Now clear the nozzle or hose.

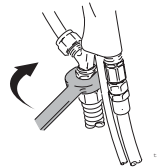

Prepare the Gun for Service

WARNING

Electric Shock Hazard



Installing and repairing this equipment requires access to parts that may cause electric shock or other serious injury if the work is not performed properly. Do not install or service this equipment unless you are trained and qualified.

WARNING

Pressurized Equipment Hazard



To reduce the risk of injury, follow the **Pressure Relief Procedure** on page 23 before checking or servicing any part of the system and whenever you are instructed to relieve the pressure.

- Check all possible remedies in **Troubleshooting** before disassembling the gun.
 - Use a vise with padded jaws to prevent damage to plastic parts.
 - Lubricate the power supply o-ring (18a) and some packing rod parts (26) with dielectric grease (40), as specified in the text.
 - Lightly lubricate o-rings and seals with non-silicone grease. Order Part No. 111265 Lubricant. Do not over-lubricate.
 - Only use genuine Graco parts. Do not mix or use parts from other PRO Gun models.
 - Air Seal Repair Kit 244781 is available. The kit must be purchased separately. Kit parts are marked with an asterisk, for example (6*).
 - Fluid Seal Repair Kit 244911 is available. The kit must be purchased separately. Kit parts are marked with a double asterisk, for example (5**).
1. Flush the gun, page 15.
 2. Relieve the pressure, page 23.
 3. Disconnect the gun air and fluid lines.
 4. Remove the gun from worksite. Repair area must be clean.

Air Cap/Nozzle Replacement

CAUTION

Hold the front end of the gun up and trigger the gun while removing the nozzle to help drain the gun and prevent any paint or solvent left in the gun from entering the air passages.

1. Prepare gun for service, page 24.
2. Remove the retaining ring (27) and air cap (9). See FIG. 9..
3. Point gun up and squeeze trigger while removing the fluid nozzle (7) assembly with the multi-tool (37).

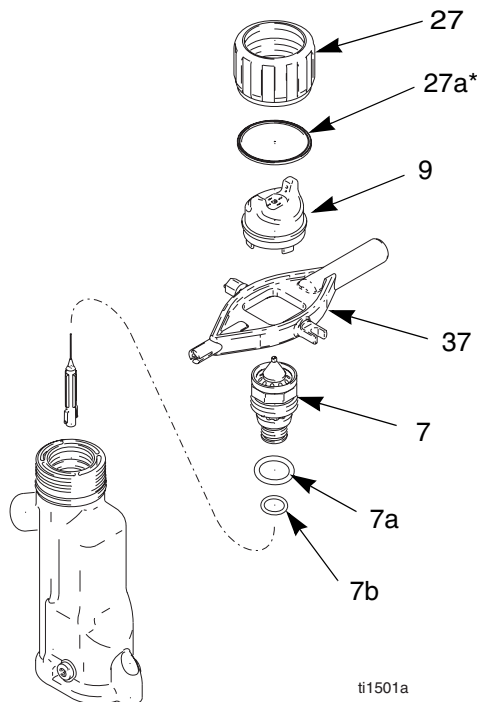

Fig. 9. Air Cap/Nozzle Replacement

WARNING

Fire, Explosion, and Electric Shock Hazard



The nozzle contact ring (7a) is a conductive contact ring, not a sealing o-ring. To reduce the risk of sparking or electric shock, do not remove the nozzle contact ring (7a) except to replace it and never operate the gun without the contact ring in place. Do not replace the contact ring with anything but a genuine Graco part.

Use non-silicone grease, Part No. 111265, on the small o-ring (7b). Do not over-lubricate. Do not lubricate the contact ring (7a).

4. Lightly lubricate the o-ring (7b). . Install it and the contact ring (7a) on the nozzle (7).

Make sure the electrode needle (29) is finger-tight (page 26).

5. Trigger gun while installing the fluid nozzle (7) with the multi-tool (37). Tighten until the fluid nozzle seats in the gun barrel (1/8 to 1/4 turn past hand-tight).
6. Install the air cap (9) and retaining ring (27). Make sure the u-cup (27a*) is in place with the lips facing forward.
7. Test gun resistance, page 17.

Electrode Replacement

1. Prepare the gun for service, page 24.
2. Remove the air cap and nozzle, page 25.
3. Unscrew the electrode (29) with the multi-tool (37). Hold the packing rod end (26h) to prevent it from turning. See FIG. 10..

 **CAUTION**

To avoid damaging the plastic threads, be very careful when installing the electrode.

4. Apply low-strength (purple) Loctite® or equivalent thread sealant to the electrode and packing rod threads. Install the electrode finger-tight. Do not overtighten.
5. Install the fluid nozzle and air cap, page 25.
6. Test gun resistance, page 17.

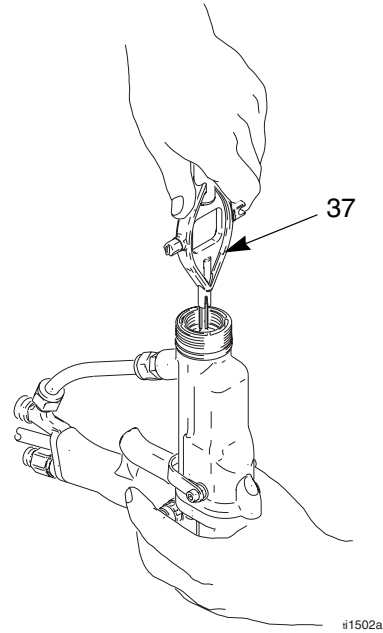

Fig. 10. Electrode Replacement

Fluid Packing Removal

1. Prepare the gun for service, page 24.
2. Remove the air cap and fluid nozzle, page 25.
3. Remove the electrode, page 26.
4. Remove the trigger screws (8) and trigger (30). See FIG. 11.
5. Remove the packing rod (26), using the multi-tool (37).

CAUTION

Clean all parts in non-conductive solvent compatible with the fluid being used, such as xylol or mineral spirits. Use of conductive solvents can cause the gun to malfunction.

6. Check all parts for wear or damage and replace if necessary.

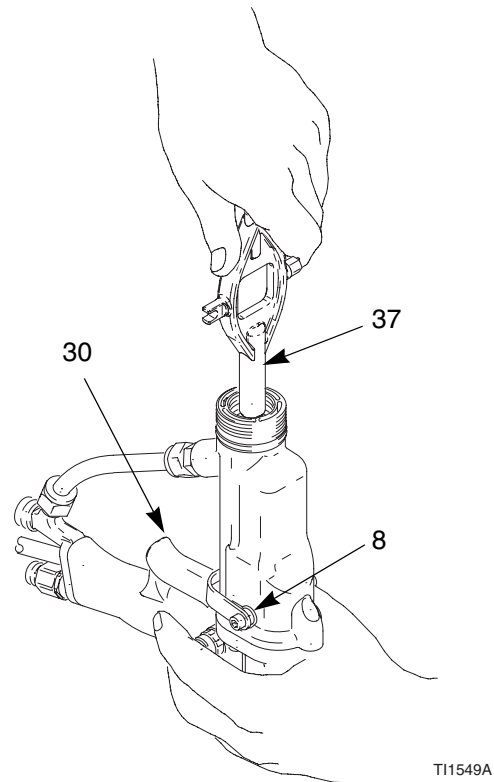

Fig. 11. Fluid Packing Removal

Packing Rod Repair

You may replace the packing rod as individual parts or as an assembly. The assembly is pre-adjusted at the factory.

Before installing the fluid packing rod into the gun barrel, make sure the internal surfaces of the barrel are clean. Remove any residue with a soft brush or cloth. Check the inside of the barrel for marks from high voltage arcing. If marks are present, replace the barrel.

To assemble the individual parts:

1. Place the packing nut (26e) and seal (26b**) on the fluid rod (26h). Flats on the packing nut must face the back of the fluid rod. The seal o-ring must face away from the packing nut. See FIG. 12.
2. Fill the inner cavity of the spacer (26g**) with dielectric grease (40). Place the spacer on the fluid rod (26h) in the direction shown. Generously apply dielectric grease to the outside of the spacer.
3. Place the fluid packing (26c**), rod packing (26d**), and housing (26f) on the packing rod (26h) .

4. Lightly tighten the packing nut (26e). The packing nut is properly tightened when there is 3 lb (13.3 N) of drag force when sliding the packing housing (26f) assembly along the rod. Tighten or loosen the packing nut as needed.
5. Install the o-ring (26a**) on the outside of housing (26f). Lubricate the o-ring with non-silicone grease, Part No. 111265. Do not over-lubricate.
6. Install the spring (4) against the nut (E) as shown.
7. Install the packing rod assembly (26) into the gun barrel. Using the multi-tool (37), tighten the assembly until just snug.
8. Install the trigger (30) and screws (8).
9. Install the electrode, page 26.
10. Install the nozzle and air cap, page 25.
11. Test gun resistance, page 17.

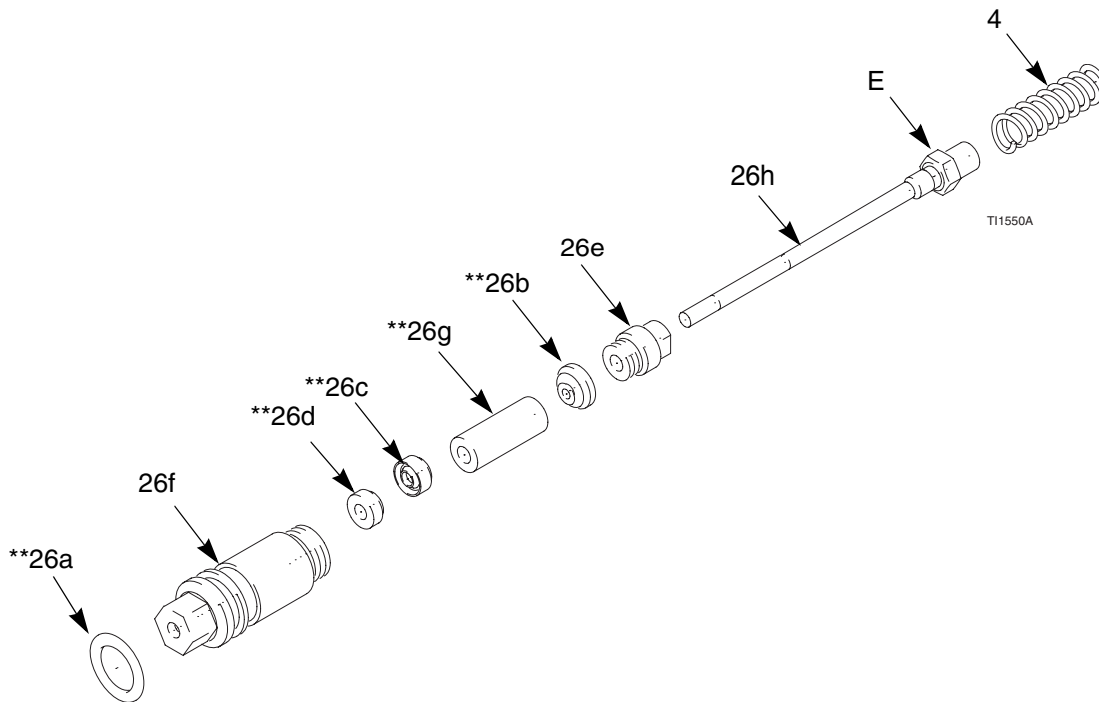

Fig. 12. Packing Rod

Barrel Removal

1. Prepare the gun for service, page 24.
2. Carefully loosen the nut (32) from the bracket fluid fitting (13). Pull the tube (14) out of the fitting. Make sure both ferrules and the nut stay with the tube.
3. Loosen the three screws (11).

CAUTION

To avoid damaging the power supply (18), pull the gun barrel straight away from the gun handle. If necessary, gently move the gun barrel from side to side to free it from the gun handle.

4. Hold the gun handle (17) with one hand and pull the barrel (16) straight off the handle. See FIG. 13..

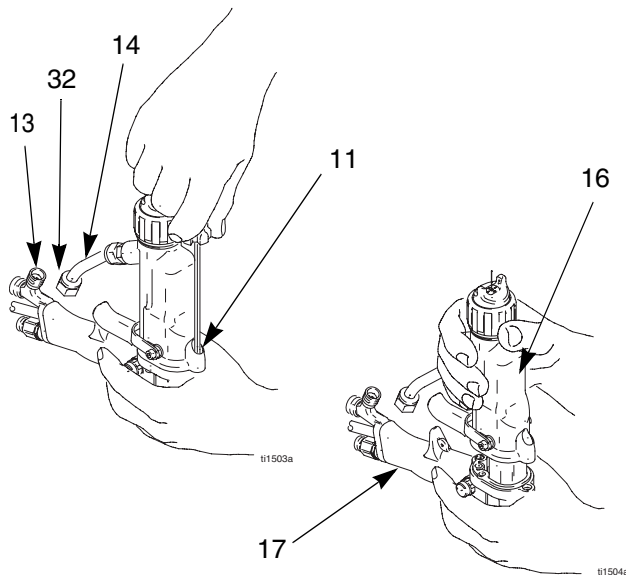

Fig. 13. Barrel Removal

Barrel Installation

1. Be sure the gasket (10*) is in place. Make sure the air holes are aligned properly. Replace if damaged. See FIG. 14..
2. Place the barrel (16) over the power supply (18) and onto the gun handle (17).
3. Tighten the three screws (11) oppositely and evenly (about a half turn past snug).

CAUTION

Do not over-tighten the screws (11).

4. Assemble the fluid tube (14) into the bracket fitting (13). Ensure that the ferrules are in place. Tighten the nut (32).
5. Test gun resistance, page 17.

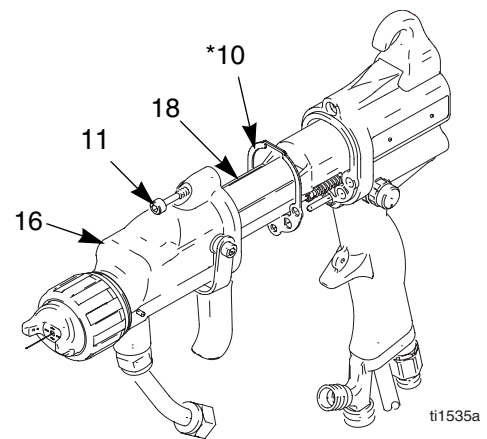

Fig. 14. Barrel Installation

Power Supply Removal and Replacement

- Inspect the gun handle power supply cavity for dirt or moisture. Clean with a clean, dry rag.
- Do not expose gasket (10) to solvents.

1. Prepare gun for service, page 24.

2. Remove the barrel (16), page 29.

CAUTION

Be careful when handling the power supply (18) to avoid damaging it.

3. Grasp the power supply (18) with your hand. With a gentle side to side motion, free the power supply/alternator assembly from the gun handle (17), then carefully pull it straight out. See FIG. 15..
4. Disconnect the 3-wire connector (GG) from the power supply. Slide the alternator up and off the power supply. Inspect the power supply and alternator for damage.
5. Check the power supply resistance, page 18. Replace if necessary.

Before installing the power supply, make sure the o-rings (18a*, 19a*), spring (18b), and pads (19e) are in place.

6. Connect the 3-wire connector (GG). Slide the alternator (19) down onto the power supply (18).

7. Lubricate the alternator o-ring (19a*) with non-silicone grease, Part No. 111265. Do not over-lubricate.
8. Lubricate the power supply o-ring (18a*) with dielectric grease (40).
9. Insert the power supply/alternator assembly in the gun handle (17). Make sure the ground strips make contact with the handle.
10. Install the barrel (16), page 29.
11. Test gun resistance, page 17.

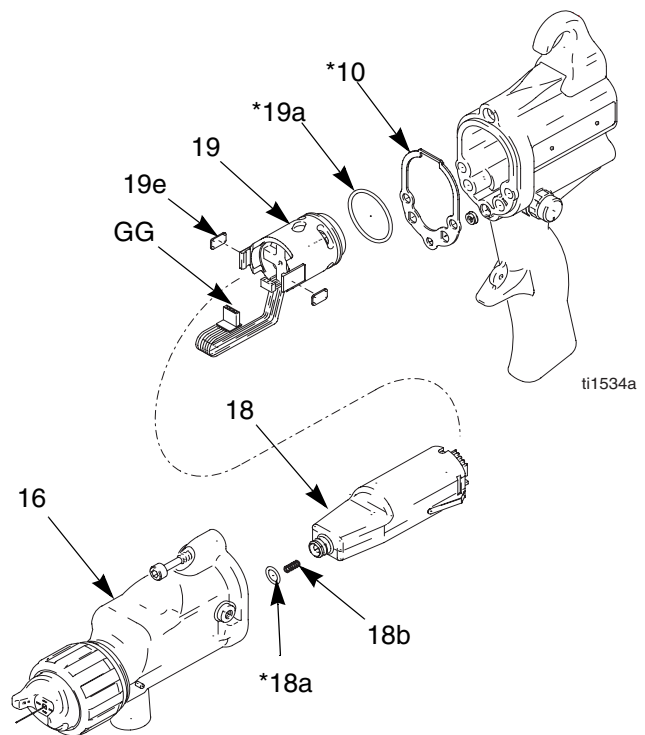

Fig. 15. Power Supply

Turbine Alternator Removal and Replacement

Replace turbine alternator bearings after 2000 hours of operation. Order Part No. 223688 Bearing Kit.

1. Prepare gun for service, page 24.
2. Remove the power supply/alternator assembly, page 30.
3. Disconnect the alternator from the power supply, page 30.
4. Measure resistance between the two outer terminals of the 3-wire connector (GG); it should be 2.5-3.5 ohms. If outside this range, replace the alternator coil.
5. Follow the bearing replacement procedure in the bearing kit manual 308034.
6. Install the alternator on the power supply, page 30.
7. Install the power supply/alternator assembly, page 30.

Fan Air Adjustment Valve Repair

1. Prepare the gun for service, page 24.
2. Place a wrench on the flats of the valve assembly (20) and unscrew it from the handle (17). You may replace the valve as an assembly (go to step 9) or as individual parts (steps 3-9).
3. Remove the retaining ring (20a). See FIG. 16..
4. Turn the valve stem (20d) counterclockwise until it comes free from the valve housing (20c).
5. Remove the o-ring (20b).
6. Clean all parts and inspect for wear or damage. Use non-silicone grease, Part No. 111265. Do not over-lubricate.
7. When reassembling the fan air valve (20), lightly lubricate the valve threads and screw the stem (20d) fully into the housing (20c) until bottomed. Install the o-ring (20b*), lubricate, and unscrew the valve stem until the o-ring enters the housing.
8. Reassemble the retaining ring (20a). Unscrew the valve stem from the housing until it is stopped by the retaining ring.
9. Screw the valve assembly (20) into the gun handle, using a wrench on the flats of the housing. Torque to 15-25 in-lb (1.7-2.8 N•m).

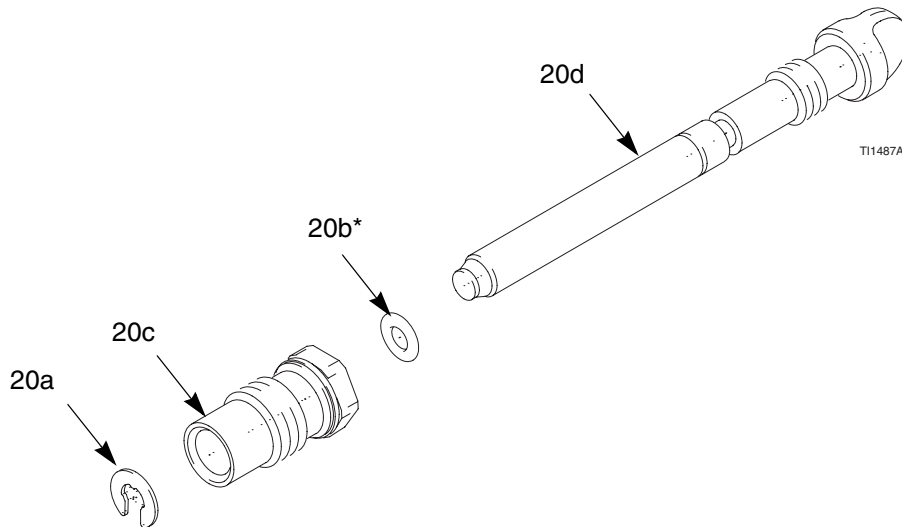

Fig. 16. Fan Air Adjustment Valve

Fluid Adjustment Valve Repair

1. Prepare the gun for service, page 24.
2. Remove the fluid adjustment valve (25). It can only be replaced as a complete assembly. See FIG. 17..
3. Screw the valve (25) into the gun handle. Torque to 15-25 in-lb (1.7-2.8 N•m).

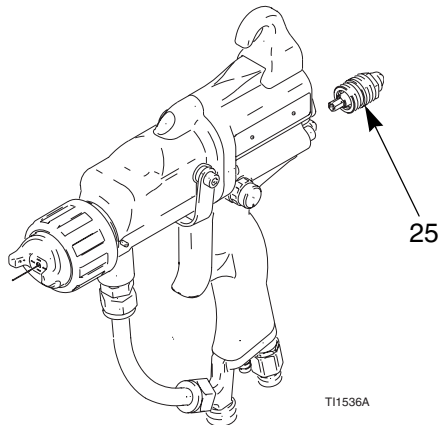

Fig. 17. Fluid Adjustment Valve

Air Valve Repair

1. Prepare the gun for service, page 24.
2. Remove the barrel, page 29.
3. Remove the fluid adjustment valve (25) from the handle (17). Remove the spring (15). See FIG. 18..

CAUTION

Clean all parts in non-conductive solvent compatible with the fluid being used, such as xylol or mineral spirits. Use of conductive solvents can cause the gun to malfunction.

4. Remove the air valve (21) with a pliers. Inspect the rubber sealing surface and replace the air valve if damaged.

CAUTION

When removing the air valve (21) be careful not to damage the seat area. The rubber seal is not removable.

5. Inspect the u-cup (6*). Do not remove the u-cup unless damaged. If removed, install the new one with its lips facing into the gun handle (17).
6. Install the air valve (21) and spring (15) into the gun handle (17).
7. Install the fluid adjustment valve (25). Torque to 15-25 in-lb (1.7-2.8 N•m).
8. Install the barrel, page 29.

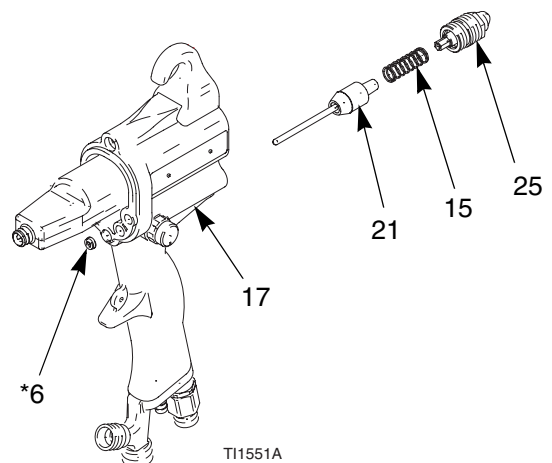

Fig. 18. Air Valve

Atomizing Air Restrictor Valve Removal and Replacement

1. Prepare the gun for service, page 24.
2. Remove the atomizing air restrictor valve (23). Inspect the o-ring (23c*). Replace if necessary. See FIG. 19..
3. Install a new atomizing air restrictor valve (23), or disassemble and replace parts individually. The valve protrusion must be oriented to clear the air valve (21) shaft.

If the atomizing air valve is not desired, install the supplied plug (47).

4. Torque the valve housing (23a) to 15-20 in-lb (1.7-2.3 N•m).

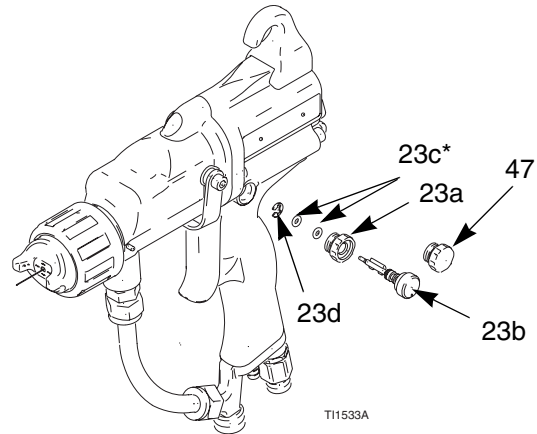

Fig. 19. Atomizing Air Valve

ES ON/OFF Valve Repair

1. Prepare the gun for service, page 24.
2. Loosen the screw (48). Remove the valve.
3. Lubricate the o-rings (22a* and 22b*) with non-silicone grease, Part No. 111265. Do not over-lubricate.

CAUTION

Do not over-lubricate parts. Excessive lubricant on the o-rings can be pushed into the gun air passage and blemish the finish on the workpiece.

4. Clean and inspect parts for damage. Replace if necessary.

The protrusion on the retainer plate (22d) must point upward.

5. Reinstall the valve. Torque the screw (48) to 15-25 in-lb (1.7-2.8 N•m).

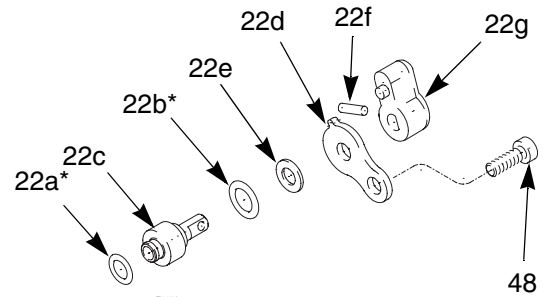
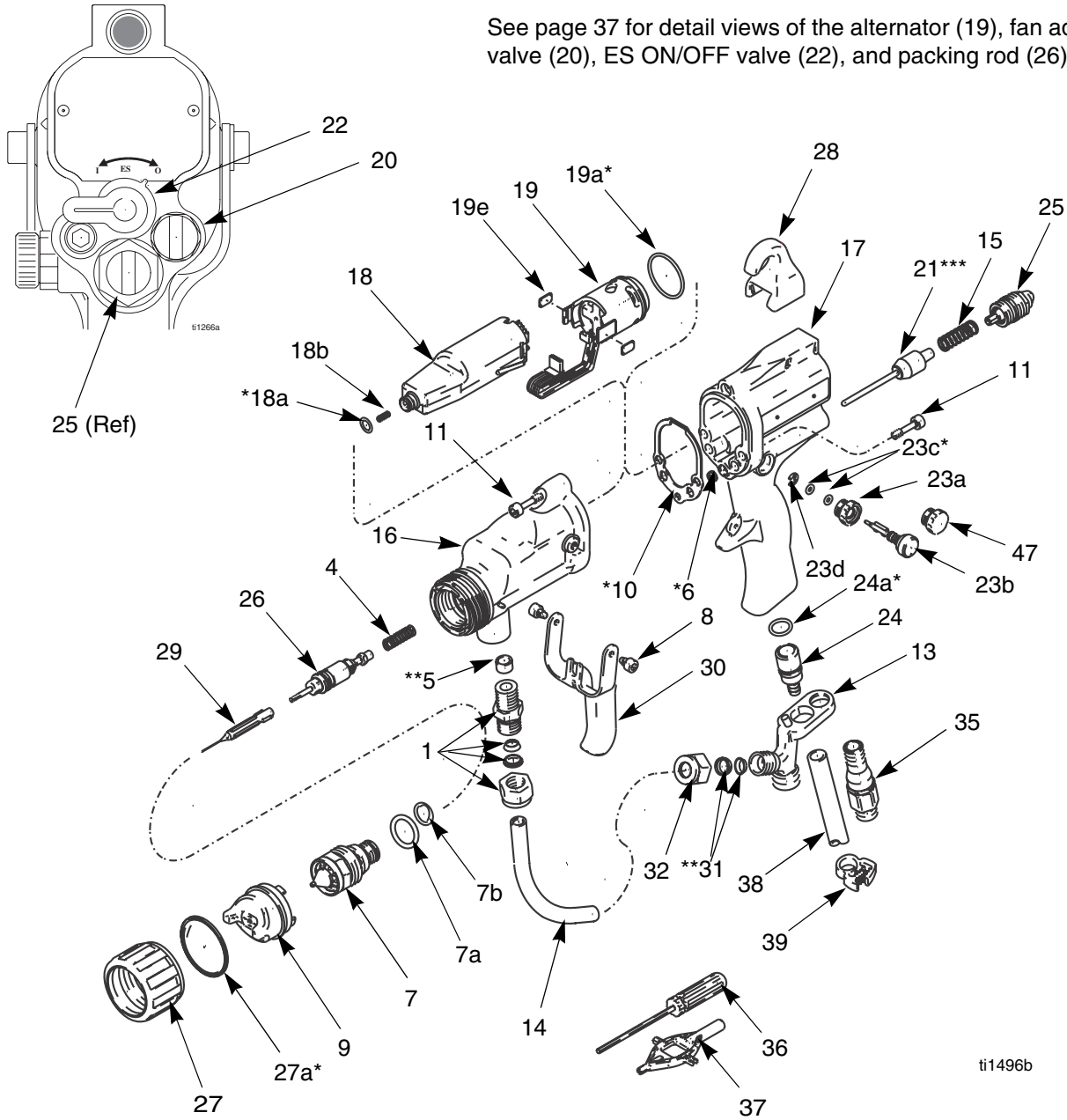

Fig. 20. ES ON/OFF Valve

Parts

Part No. 244399 20 kV Electrostatic Gun, Series C

See page 37 for detail views of the alternator (19), fan adjustment valve (20), ES ON/OFF valve (22), and packing rod (26).



ti1496b

Ref. No. 19: Alternator

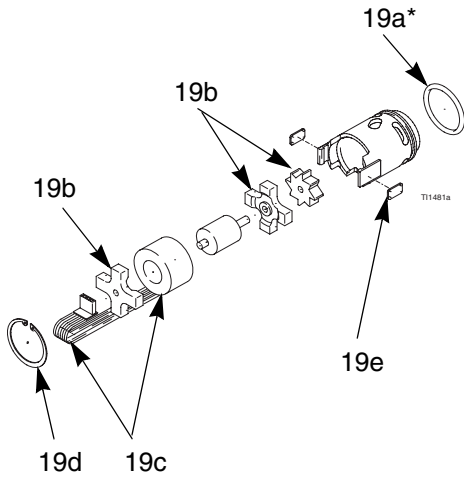

Ref. No. 20: Fan Adjustment Valve

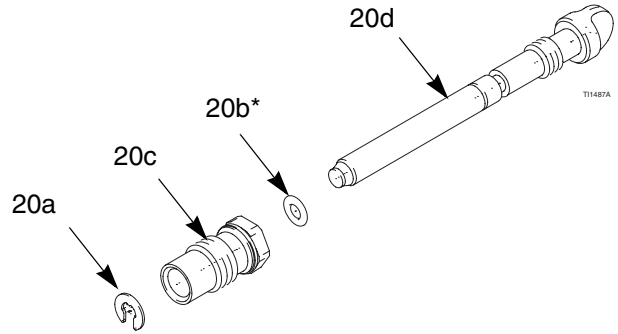

Ref. No. 22: ES ON/OFF Valve

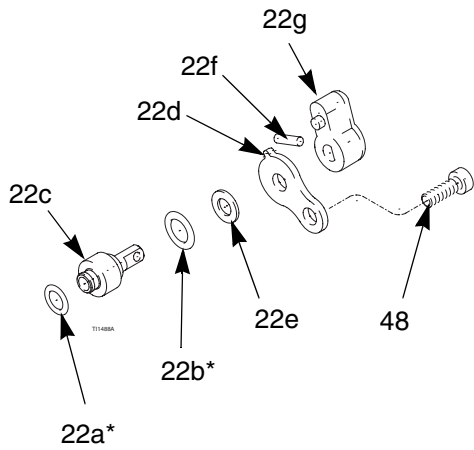

Ref. No. 26: Packing Rod

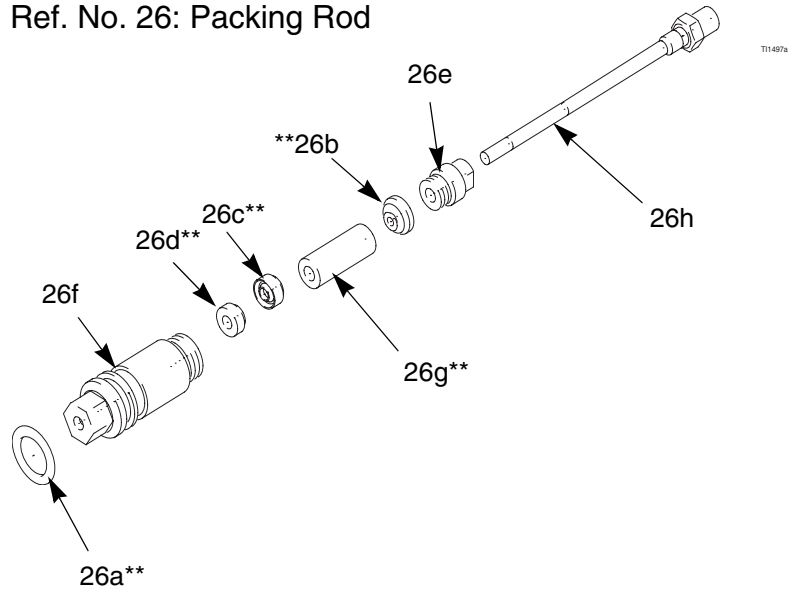

Parts

Ref. No.	Part No.	Description	Qty	Ref. No.	Part No.	Description	Qty
1	110078	FITTING, tube, fluid; includes one each of items 31 and 32	1	23c*	111504	.O-RING; fluoroelastomer	2
4	185111	SPRING, compression	1	23d	101021	.RING, retaining	1
5**	185120	SPACER, fluid; nylon	1	24	249323	VALVE, exhaust; includes item 24a	1
6*	188749	PACKING, u-cup, air valve; UHMWPE	1	24a*	112085	.O-RING; fluorocarbon	1
7	197266	NOZZLE; 1.5 mm orifice; includes items 7a and 7b	1	25	244593	VALVE, adjustment, fluid	1
7a	111261	.O-RING, conductive	1	26	244598	ROD, packing; includes items 26a-26h	1
7b	111507	.O-RING; fluoroelastomer	1	26a**	111316	.O-RING; fluoroelastomer	1
8	197369	SCREW, trigger	2	26b**	116905	.SEAL	1
9	24A376	AIR CAP	1	26c**	178409	.PACKING, fluid; UHMWPE	1
10*	197517	GASKET, barrel	1	26d**	178763	.PACKING, rod; acetal homopolymer	1
11	197518	SCREW; socket-hd; 10-24 x 3/4 in. (19 mm)	3	26e	185488	.NUT, packing	1
13	15M678	BRACKET, inlet, fluid	1	26f	185495	.HOUSING, packing	1
14	197589	TUBE, fluid	1	26g**	186069	.SPACER, packing; acetal	1
15	185116	SPRING, compression	1	26h	244694	.ROD, packing	1
16	244396	BARREL, gun	1	27	244927	RING, retaining, air cap; includes item 27a	1
17	245289	HANDLE, gun (includes item 28)	1	27a*	198307	.PACKING, u-cup	1
18	244539	POWER SUPPLY, 20 kV; includes items 18a-18b	1	28	276695	HOOK	1
18a*	103337	.O-RING; fluoroelastomer	1	29****	276697	NEEDLE, electrode	1
18b	197624	.SPRING, compression	1	30	276698	TRIGGER	1
19	244555	TURBINE, alternator; includes items 19a-19e	1	31**	110077	FERRULE, tube, fluid	1
19a*	110073	.O-RING; fluoroelastomer	1	32	110079	NUT, tube, fluid	1
19b	223688	.BEARING KIT; includes front and rear bearings and fan	1	35	244834	SWIVEL, air; 1/4 npsm(m); left-hand threads	1
19c	244577	.COIL	1	36	107460	WRENCH, ball end	1
19d	111745	.RING, retaining	1	37	276741	MULTI-TOOL	1
19e	198821	.PAD, pressure	2	38	185103	TUBE, exhaust	1
20	244556	VALVE, adjustment, fan; includes items 20a-20d	1	39	110231	CLAMP	1
20a	101021	.RING, retaining	1	40	116553	GREASE, dielectric, tube (not shown)	1
20b*	106560	.O-RING; fluorocarbon	1	41	244914	COVER, gun; box of 10 (not shown)	1
20c	197566	.HOUSING, fan valve	1	42▲	179791	TAG, warning (not shown)	1
20d	197567	.STEM, fan valve	1	43▲	180060	SIGN, warning (not shown)	1
21***	244557	VALVE, air	1	47	197967	PLUG	1
22	244558	VALVE, electrostatics, ON/OFF; includes items 22a-22g	1	48	198058	SCREW, cap, socket hd	1
22a*	111516	.O-RING; CV75	1	49	24A431	KIT, wide pattern (not shown)	1
22b*	113137	.O-RING; fluoroelastomer	1	* Included in Air Seal Repair Kit 244781.			
22c	198403	.SHAFT, valve	1	** Included in Fluid Seal Repair Kit 244911.			
22d	198404	.PLATE, retaining	1	*** Rubber seal is not removable.			
22e	198453	.WASHER	1	**** Optional replacement Electrode Needle 277007 is available for abrasive materials.			
22f	198464	.PIN	1	▲ Replacement Warning labels, signs, tags, and cards are available at no cost.			
22g	276753	.KNOB	1				
23	244559	VALVE, air, atomizing; includes items 23a-23d	1				
23a	197594	.HOUSING, valve	1				
23b	197591	.SHAFT	1				

Accessories

Air Line Accessories

AirFlex™ Flexible Grounded Air Hose

100 psi (7 bar, 0.7 MPa) Maximum Working Pressure

0.315 in. (8 mm) ID; 1/4 npsm(f) x 1/4 npsm(f) left-hand thread. Use for maximum flexibility.

244963	6 ft (1.8 m)
244964	15 ft (4.6 m)
244965	25 ft (7.6 m)
244966	36 ft (11 m)
244967	50 ft (15 m)
244968	75 ft (23 m)
244969	100 ft (30.5 m)

Standard Grounded Air Hose

100 psi (7 bar, 0.7 MPa) Maximum Working Pressure

0.315 in. (8 mm) ID; 1/4 npsm(f) x 1/4 npsm(f) left-hand thread

223068	6 ft (1.8 m)
223069	15 ft (4.6 m)
223070	25 ft (7.6 m)
223071	36 ft (11 m)
223072	50 ft (15 m)
223073	75 ft (23 m)
223074	100 ft (30.5 m)

Bleed-Type Master Air Valve

300 psi (21 bar, 2.1 MPa) Maximum Working Pressure

Relieves air trapped in the air line between this valve and the pump air motor when closed.

107141	3/4 npt
---------------	---------

Air Line Shutoff Valve

150 psi (10 bar, 1.0 MPa) Maximum Working Pressure

For turning air to gun on or off.

224754	1/4 npsm(m) x 1/4 npsm(f) left-hand thread.
---------------	---

Air Line Quick Disconnect

112534	Swiveling quick disconnect replaces standard air inlet swivel.
---------------	--

Air Hose Adapter Nipple

185493	Use to connect multiple air hoses. 1/4 npt x 1/4 npsm left-hand thread.
---------------	---

Non-Swivel Air Inlet Fitting

185105	Replaces standard swivel. Left-hand thread.
---------------	---

Extended Air Inlet Fitting

189191	Replaces standard swivel to provide extended handle grip area. Left-hand thread.
---------------	--

Fluid Line Accessories

Fluid Hose

225 psi (14 bar, 1.4 MPa) Maximum Working Pressure

FM Approved; nylon; 3/8 npsm(fbe)

215637	1/4 in. (6 mm) ID x 25 ft (7.6 m)
215638	1/4 in. (6 mm) ID x 50 ft (15.2 m)

Fluid Shutoff/Drain Valve

500 psi (35 bar, 3.5 MPa) Maximum Working Pressure

For turning fluid on or off to the gun and for relieving fluid line pressure at the pump.

208630	1/2 npt(m) x 3/8 npt(f); carbon steel and PTFE; for non-corrosive fluids
---------------	--

Fluid Swivel

5800 psi (405 bar, 40 MPa) Maximum Working Pressure

115898	1/4 npsm(m) x 1/4 npsm(f)
---------------	---------------------------

Gun Accessories

Gun Repair Kits

- 244781 Air Seal Repair Kit
- 244911 Fluid Seal Repair Kit

Round Pattern Kits

Consists of fluid tip, diffuser and air cap.

- 245217 4-6 in. (102-152 mm) diameter
- 245219 8-10 in. (203-254 mm) diameter

Adjustable Round Pattern Kit

- 277851 Slow velocity, bell shaped spray pattern for excellent transfer efficiency. Pattern is adjustable from 6-12 in.

Push/Pull Fan Air Valve

- 244912 For quick change of fan size.

ES Always On Kit

- 244913 Replaces inlet fitting with ball valve to shut off air during flushing. Converts ES ON/OFF valve to always ON condition.

Handle Grips

- 245263 Medium Grip
- 245264 Large Grip

Gun Washer Kit

- 245270 Use to convert Graco gun washers so they can clean PRO Xs2 air spray guns.

Pressure Cups

Includes air regulators for gun atomization air and supply air to pressure cup.

- 244731 1 Quart (0.95 Liter)
- 244732 2 Quart (1.90 Liter)

Gun Valve Lubricant

- 111265 4 oz (113 g) tube of sanitary (non-silicone) lubricant for fluid seals and wear areas.

Alternator Bearing Kit

- 223688 To repair the turbine alternator.

Cleaning Brush

- 105749 For cleaning air cap and fluid nozzle.

Abrasive Material Electrode Needle

- 277007 Optional replacement Electrode Needle is available for abrasive materials.

Miscellaneous Accessories

Ground Wire and Clamp

- 222011 For grounding pump and other components and equipment in the spray area. 12 gauge, 25 ft (7.6 m).

Megohmmeter

- 241079 500 Volt output; 0.01-2000 megohms.
Not for use in hazardous areas.

Paint Resistance Meter

- 722886 Use with 722860 Paint Probe to measure resistance of paint.
Not for use in hazardous areas.

Paint Probe

- 722860 Use with 722886 Paint Resistance Meter to measure resistance of paint.
Not for use in hazardous areas.

Safety Warning Signs

- 180060 English Warning Sign. FM Approved. Available at no charge from Graco.

Instruction Signs

- 198309 English Setup Instructions.
- 198319 English Daily Care Instructions.

Electrostatic Conductive Gloves (box of 12)

- 117823 Small
- 117824 Medium
- 117825 Large

Technical Data

Category

Maximum Working Fluid Pressure
 Maximum Working Air Pressure
 Minimum Air Pressure at Gun Inlet
 Maximum Fluid Operating Temperature
 Paint Resistivity Range
 Short Circuit Current Output
 Voltage Output
 Sound Power (measured per ISO Standard 9216)

 Sound Pressure (measured 1 m from gun)

 Air inlet fitting, left-hand thread
 Fluid inlet fitting
 Gun Weight
 Gun Length
 Wetted Parts

Data

100 psi (0.7 MPa, 7 bar)
 100 psi (0.7 MPa, 7 bar)
 40 psi (0.28 MPa, 2.8 bar)
 120°F (48°C)
 3 megohm-cm to infinity
 125 microamperes
 20 kV
 at 40 psi (0.28 MPa, 2.8 bar): 90.4 dB(A)
 at 100 psi (0.7 MPa, 7 bar): 105.4 dB(A)
 at 40 psi (0.28 MPa, 2.8 bar): 87 dB(A)
 at 100 psi (0.7 MPa, 7 bar): 99 dB(A)
 1/4 npsm(m)
 3/8 npsm(m)
 23.5 oz (668 g)
 8.6 in. (21.8 cm)
 Stainless Steel, Nylon, Acetal, Ultra-High Molecular
 Weight Polyethylene, Fluoroelastomer, PEEK, Tungsten
 Wire, Polyethylene

Loctite® is a registered trademark of the Loctite Corporation.

Graco Standard Warranty

Graco warrants all equipment manufactured by Graco and bearing its name to be free from defects in material and workmanship on the date of sale to the original purchaser for use. With the exception of any special, extended, or limited warranty published by Graco, Graco will, for a period of twelve months or two thousand hours of operation from the date of sale, repair or replace any part of the equipment determined by Graco to be defective. However, any deficiency in the barrel, handle, trigger, hook, internal power supply, and alternator (excluding turbine bearings) will be repaired or replaced for thirty-six months or six thousand hours of operation from the date of sale. This warranty applies only when the equipment is installed, operated and maintained in accordance with Graco's written recommendations.

This warranty does not cover, and Graco shall not be liable for general wear and tear, or any malfunction, damage or wear caused by faulty installation, misapplication, abrasion, corrosion, inadequate or improper maintenance, negligence, accident, tampering, or substitution of non-Graco component parts. Nor shall Graco be liable for malfunction, damage or wear caused by the incompatibility of Graco equipment with structures, accessories, equipment or materials not supplied by Graco, or the improper design, manufacture, installation, operation or maintenance of structures, accessories, equipment or materials not supplied by Graco.

This warranty is conditioned upon the prepaid return of the equipment claimed to be defective to an authorized Graco distributor for verification of the claimed defect. If the claimed defect is verified, Graco will repair or replace free of charge any defective parts. The equipment will be returned to the original purchaser transportation prepaid. If inspection of the equipment does not disclose any defect in material or workmanship, repairs will be made at a reasonable charge, which charges may include the costs of parts, labor, and transportation.

THIS WARRANTY IS EXCLUSIVE, AND IS IN LIEU OF ANY OTHER WARRANTIES, EXPRESS OR IMPLIED, INCLUDING BUT NOT LIMITED TO WARRANTY OF MERCHANTABILITY OR WARRANTY OF FITNESS FOR A PARTICULAR PURPOSE.

Graco's sole obligation and buyer's sole remedy for any breach of warranty shall be as set forth above. The buyer agrees that no other remedy (including, but not limited to, incidental or consequential damages for lost profits, lost sales, injury to person or property, or any other incidental or consequential loss) shall be available. Any action for breach of warranty must be brought within two (2) years of the date of sale.

Graco makes no warranty, and disclaims all implied warranties of merchantability and fitness for a particular purpose in connection with accessories, equipment, materials or components sold but not manufactured by Graco. These items sold, but not manufactured by Graco (such as electric motors, switches, hose, etc.), are subject to the warranty, if any, of their manufacturer. Graco will provide purchaser with reasonable assistance in making any claim for breach of these warranties.

In no event will Graco be liable for indirect, incidental, special or consequential damages resulting from Graco supplying equipment hereunder, or the furnishing, performance, or use of any products or other goods sold hereto, whether due to a breach of contract, breach of warranty, the negligence of Graco, or otherwise.

FOR GRACO CANADA CUSTOMERS

The parties acknowledge that they have required that the present document, as well as all documents, notices and legal proceedings entered into, given or instituted pursuant hereto or relating directly or indirectly hereto, be drawn up in English. Les parties reconnaissent avoir convenu que la rédaction du présente document sera en Anglais, ainsi que tous documents, avis et procédures judiciaires exécutés, donnés ou intentés à la suite de ou en rapport, directement ou indirectement, avec les procédures concernées.

Graco Information

For the latest information about Graco products, visit www.graco.com.

TO PLACE AN ORDER, contact your Graco distributor, or call this number to identify the distributor closest to you:
1-800-328-0211 **Toll Free** • 612-623-6921 • 612-378-3505 **Fax**

*All written and visual data contained in this document reflects the latest product information available at the time of publication.
Graco reserves the right to make changes at any time without notice.*

This manual contains English. MM 309291

Graco Headquarters: Minneapolis

International Offices: Belgium, China, Japan, Korea

GRACO INC. P.O. BOX 1441 MINNEAPOLIS, MN 55440-1441

Copyright 2001, Graco Inc. is registered to ISO 9001

www.graco.com

Revised 10/2009