

Assembly Instructions

English



Grundig SAT Systems

PROFESSIONAL

Head-End Converter DVB-C/T to MPTS

PCIM 1000



GSS
Grundig SAT Systems GmbH
Beuthener Strasse 43
D-90471 Nuremberg

Phone: +49 (0) 911 / 703 8877
Fax: +49 (0) 911 / 703 9210
E-mail: info@gss.de
Internet: <http://www.gss.de>

1	Safety regulations and notes	4
2	General information	5
2.1	Packing contents	5
2.2	Meaning of the symbols used.....	5
2.3	Technical specifications	5
2.4	Description	6
	Input signal path "INROUTE"	7
	Menu setting "A+ASI = 1 B+ASI = 2"	7
	Menu setting "A+B+ASI = 1 ASI = 2"	7
	Menu setting "A+ASI = 1 A+ASI = 2"	7
	Output signal path "OUTROUTE"	8
	Menu setting "ASI => ASI"	8
	Menu setting "1 => ASI ASI => MA"	8
	Menu setting "2 => ASI ASI => MB"	8
	General	9
2.5	Software query	10
3	Assembly	11
3.1	Installing the cassette	11
3.2	EMC regulations	12
3.3	Overview of the cassette	13
3.4	Connecting the cassette.....	13
3.5	Updating the software.....	14
3.6	Retrofitting a CA module	15
4	The control panel at a glance	16
4.1	Menu items.....	16
4.2	Control panel.....	16
5	Programming	17
5.1	Programming procedure.....	17
5.2	Programming the cassette	20
	Selecting the cassette, displaying the software version	21
	Ethernet parameters.....	21
	IP address of the cassette.....	22
	Address range	22
	Address of the gateway	23
	UDP port	23
	Input signal path	24

Output signal path.....	24
ASI transfer rate.....	25
ASI options.....	25
Selecting the channel strip.....	26
Switching the IP address off or on.....	26
Transmission protocol.....	26
Port number.....	26
Quantity of data packets.....	27
Forward error correction.....	27
Transmission channel.....	27
Output IP address.....	28
LAN data rate.....	29
Input parameter.....	29
Kind of modulation.....	29
Symbol rate.....	29
Input channel / Input frequency.....	30
Station filter.....	30
"INROUTE" setting "A+B+ASI=1 ASI=2".....	31
"INROUTE" setting "A+ASI=1 B+ASI=2" and "A+ASI=1 A+ASI=2" ..	33
Output data rate.....	33
Network Information Table (NIT).....	34
Deleting a PID.....	35
Renaming a PID.....	35
Factory reset.....	36
Saving settings.....	36
Operation with a CA module.....	37
PID monitoring.....	37
CA module.....	37
Descrambling services.....	39
6 Final procedures.....	40

1 SAFETY REGULATIONS AND NOTES



- Assembly, installation and servicing should be carried out by authorised electricians.
- Switch off the operating voltage of the system before beginning with assembly or service work or pull out the mains plug.
- Do not perform installation and service work during thunderstorms.
- Install the system so it will not be able to vibrate...
 - in a dust-free, dry environment
 - in such a manner that it is protected from moisture, fumes, splashing water and dampness
 - somewhere protected from direct sunlight
 - not within the immediate vicinity of heat sources
 - in an ambient temperature of 0 °C to +50 °C. In case of the formation of condensation wait until the system is completely dried.
- Ensure that the head-end station is adequately ventilated. Do not cover the ventilation slots.
- Beware of short circuits
- No liability is accepted for any damage caused by faulty connections or inappropriate handling.
- Observe the relevant standards, regulations and guidelines on the installation and operation of antenna systems.
- The standards EN/DIN EN 50083 resp. IEC/EN/DIN EN 60728 must be observed.
- **For further information please read the assembly instructions for the head-end station used.**
- **Test the software versions of the head-end station and the cassette and update them if necessary. The current software versions can be found at "www.gss.de/en".**



Take action to prevent static discharge when working on the device!



Electronic devices should never be disposed of in the household rubbish. In accordance with directive 2002/96/EC of the European Parliament and the European Council from January 27, 2003 which addresses old electronic and electrical devices, such devices must be disposed of at a designated collection facility. At the end of its service life, please take your device to one of these public collection facilities for proper disposal.

2 GENERAL INFORMATION

2.1 PACKING CONTENTS

1	Cassette PCIM 1000	2	RF cables
1	Brief assembly instructions	1	Measuring log

2.2 MEANING OF THE SYMBOLS USED



Important note



General note

- Performing works

2.3 TECHNICAL SPECIFICATIONS

The devices meet the following EU directives:
2006/95/EC, 2004/108/EC, 2011/65/EU

The product fulfils the guidelines and standards for CE labelling (page 41).

Unless otherwise noted all values are specified as "typical".

RF input

Frequency range:	42 ... 866 MHz
Channels	C5...C12, S21...S41, C21...C69
Input level:	60 dB μ V ... 80 dB μ V
Return loss:	> 8 dB
Impedance:.....	75 Ω
Symbol rate	acc. to EN 300744

LAN interface

Standard:	100-BASE-T
Data rate:	\leq 80 MBit
Protocols:.....	UDP (User Data Protocol), RTP (Real-Time Transport Protocol)

→ Live Streaming/Multicast Streaming requires specially designed and configured networks. Minimum Requirements include:
Layer-3 Switched Ethernet, Multicast Enabled, IGMPv2/3, Network and Multicast Routing Supported.

ASI interfaces

Standard: DIN EN 50083-9
Format: MPEG ISO IEC 13818-1
User data rate: 108 Mbit/s
Impedance: 75 Ω
Level (input / output): 800 mV_{pp} ± 10%
Return loss (input): > 17 dB (5 ... 270 MHz)

Connections

RF inputs: 2 F sockets
RF output: 1 IEC socket
ASI input: 1 BNC socket, 75 Ω
ASI output: 1 BNC socket, 75 Ω
LAN: 1 RJ-45 socket
Connection strip (10-pin): for supply voltages and control circuits
RS 232 socket: serial interface for software update
Common Interface: 1 (several services can be descrambled).

Remote maintenance

Remotely controllable (via PSW 1000*): yes
(* and a corresponding management unit)

2.4 DESCRIPTION

The double transmodulator cassette converts COFDM and QAM modulated stations into two IP-MPTS transport streams. The cassette has two RF inputs and one LAN output. Additionally it is equipped with an ASI input and an ASI output (ASI – Asynchronous Serial Interface according to EN 50083-9).

The transport stream fed via the ASI socket can be inserted into the transport streams of the receiving stages via the TPS module. The signal path is set in the menu items input signal path "**INROUTE**" and output signal path "**OUTROUTE**".

INPUT SIGNAL PATH "INROUTE"

MENU SETTING "A+ASI = 1 B+ASI = 2"

The transport streams of the receiving stage "TS A" and of the ASI input "TS ASI" generate the transport stream 1. The transport streams of the receiving stage "TS B" and of the ASI input "TS ASI" generate the transport stream 2.

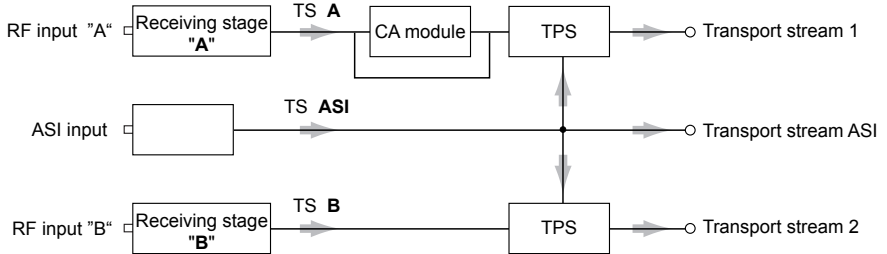

MENU SETTING "A+B+ASI = 1 ASI = 2"

The transport streams of the receiving stages "TS A" and "TS B" and of the ASI input "TS ASI" generate the transport stream 1. The "TS ASI" transport stream fed via the ASI input generates the transport stream 2.

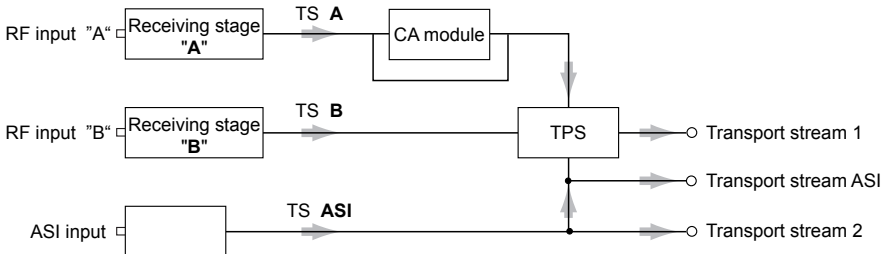

MENU SETTING "A+ASI = 1 A+ASI = 2"

The transport streams of the receiving stage "A" "TS A" and of the ASI input "TS ASI" are split into transport stream 1 and 2. Receiving stage "B" is not used.

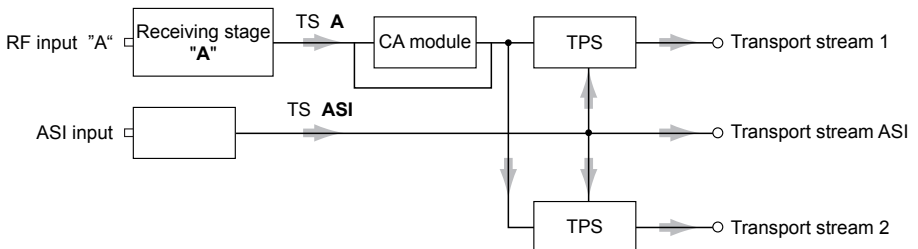

OUTPUT SIGNAL PATH "OUTROUTE"

MENU SETTING "ASI => ASI"

Transport stream 1 is made available via MPTS line "A", transport stream 2 via MPTS line "B" and the transport stream from the ASI input "TS ASI" via the ASI output.

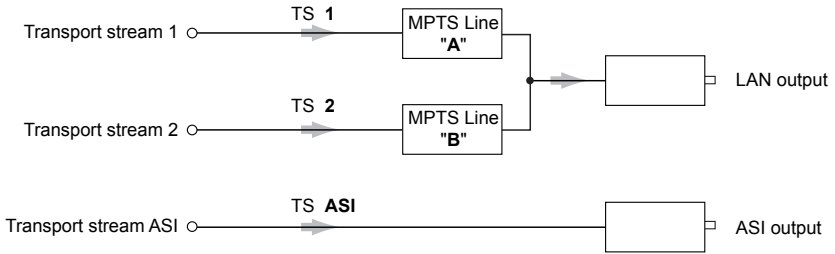

MENU SETTING "1 => ASI ASI => MA"

Transport stream 1 is made available via the ASI output, transport stream 2 via MPTS line "B" and the transport stream from the ASI input "TS ASI" via MPTS line "A" (MA).

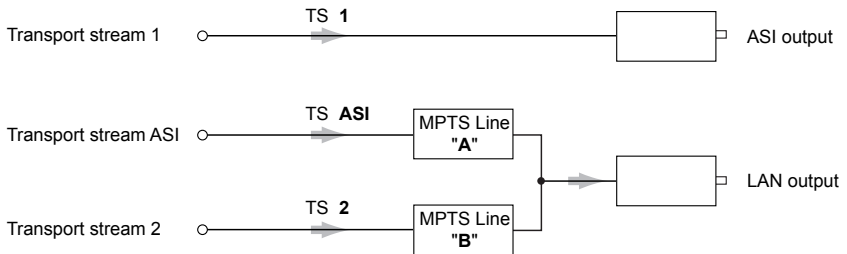

MENU SETTING "2 => ASI ASI => MB"

Transport stream 1 is made available via MPTS line "A", transport stream 2 via the ASI output and the transport stream from the ASI input "TS ASI" via MPTS line "B" (MB).

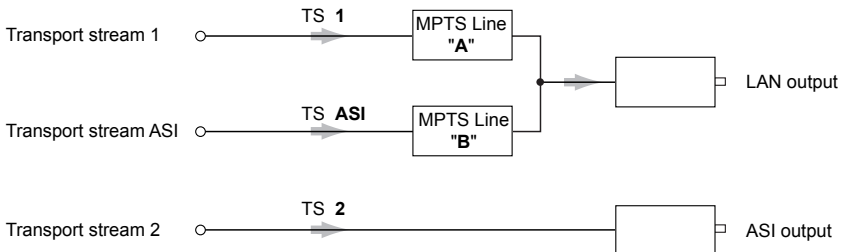

The cassette is equipped with two channel strips ("A" and "B"). The channel strips consist of the digital tuners and the digital signal preparation units. The channel strips are indicated in the head-end station display with "Bx ...A" and "Bx ...B". Using an adequate CA module scrambled channels can be descrambled via channel strip "A". The control of the cassette takes place via the control unit of the head-end station.

Two LEDs provide an indication of the input signal quality based on their colour and indicate if the respective channel strip is switched on (LED illuminates) or off. During the boot process both LEDs are blinking.

The integrated TPS module (Transport Stream Processing) processes the data of the transport streams.

For operating the cassette in a LAN network it can be assigned its own IP address. The LEDs for the LAN interface show whether a network connection exists and whether a data transfer is in progress. Two MPTS IP transport streams are output through the LAN output of the cassette.

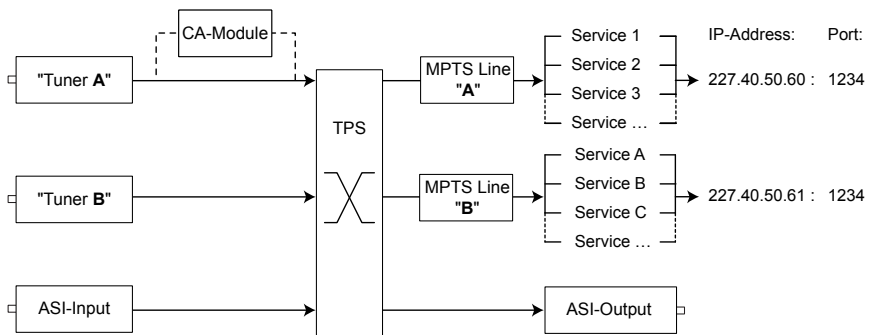

Additionally a transport stream is made available via the ASI output dependent on the signal path set.

When the head-end station is switched on, the two-line LC display shows the software version of the control unit. To operate this cassette the software version of the control unit must be "V 45" or higher. You can find the current operating software for the control unit and the cassette, the software "BE-Flash" and the current assembly instructions on the website "www.gss.de".

The cassette is intended for use in the PROFI-LINE head-end stations.

Control unit

If necessary, you can activate the indication of the software version of the control unit manually:

- Press any two keys on the control unit of the head-end station simultaneously until the display goes dark and the software version, e.g. "**V 45**" appears.

Cassette

After activating the cassette the software version of the cassette is displayed (see page 21).

3 ASSEMBLY

3.1 INSTALLING THE CASSETTE



- Ensure the head-end station is mounted so it will not be able to vibrate. Avoid, for example, mounting the head-end station onto a lift shaft or any other wall or floor construction that vibrates in a similar way.
- Before installing or changing a cassette unplug the power cable from the mains power socket.
- Remove the fastening screws ① of an unoccupied slot from the bracket of the head-end station.
- Insert the cassette in this slot and push it into the housing.
- Align the cassette and apply slight pressure to connect it to the connections of the board and the RF bus bar.
- Fasten the cassette with the screws ①.

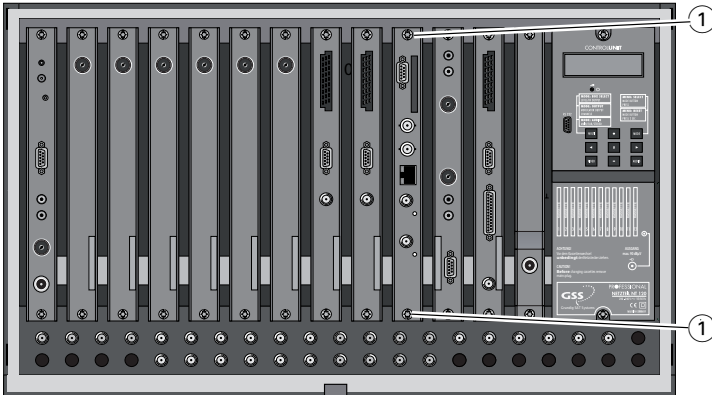

3.2 EMC REGULATIONS



To comply with the current EMC regulations, it is necessary to connect the lines leading in and out of the head-end station using cable terminals. When mounting the cassette in a head-end station which is installed in a 19" cabinet, make sure the connections leading in and out for the 19" cabinet are made using cable terminals.



The attenuation of shielding of the connection lines for ASI and antenna must meet the requirements for "Class A".

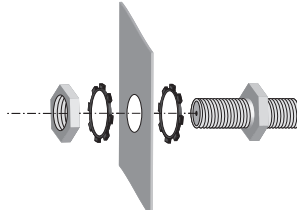

- Insert the required number of cable terminals in the openings provided in the head-end station or in the 19" cabinet.



Tighten the nuts of the cable terminals until the teeth on the lock washers put under have penetrated the exterior coating and a good connection is made between the housing / 19" cabinet and cable terminals.

3.3 OVERVIEW OF THE CASSETTE

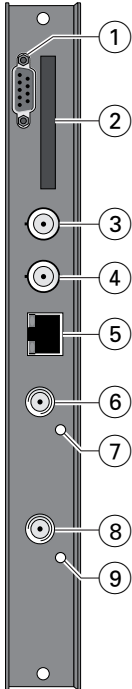

- ① D-SUB socket "RS-232"
- ② Slot for a CA module
- ③ ASI output
- ④ ASI input
- ⑤ LAN socket
- ⑥ RF input "A" (channel strip "A")
- ⑦ Status LED channel strip "A"
- ⑧ RF input "B" (channel strip "B")
- ⑨ Status LED channel strip "B"

The operating software of the cassette can be updated via the 9-pin D-SUB socket "RS-232" using a PC or notebook and the software "**BE-Flash**".

You can find the current operating software on the website "www.gss.de".

—> The status LEDs indicate the quality of the received transport streams:

LED indicator	Indication
Blinking green	Boot process
Green	Signal quality is good
Yellow	Signal quality is insufficient
Red	No signal

3.4 CONNECTING THE CASSETTE

- Connect the RF connections to the inputs ⑥ (channel strip "A") and ⑧ (channel strip "B").
- Connect the ASI input ④ and the ASI output ③ to the peripheral ASI devices.
- Connect the LAN socket ⑤.

3.5 UPDATING THE SOFTWARE

The RS 232 interface of the cassette ① enables you to use a PC or a notebook and the "**BE-Flash**" software to update the software of the cassette. You can find the "**BE-Flash**" software and the current operating software of the cassette at the website "www.gss.de/en".

Before updating, the network cable must be disconnected from the LAN socket.

- Use a "one-to-one cable" to connect the cassette's RS 232 interface and the PC according to the wiring scheme below.



—> For PCs with USB connector (without serial interface), we recommend the DeLOCK "USB 2.0 to Serial adapter" (Product No. 61460).

- Start the "**BE-Flash**" software and update the software of the cassette.

3.6 RETROFITTING A CA MODULE

The cassette is equipped with a common interface. It allows you to connect a CA module for various encryption systems and service providers. Scrambled services can only be descrambled with a CA module suitable for the scrambling system and the corresponding smart card. The smart card contains all the information for authorisation, descrambling and subscription.



- Check with the distributor or manufacturer of the CA module to be used to ensure that it is suitable for descrambling several services.
 - **The hardware and software of this cassette have been thoroughly prepared and tested.**
Any changes made by service providers in the data structures might impair or even prevent this function.
 - When working with the CA module, please read the corresponding operating manual from the respective provider.
-
- Insert the smart card ① into the CA module ② so that the chip ③ on the smart card faces the thicker side (top) of the CA module.
 - Insert the CA module into the guide rails of the CA slot ④ with the top side of the CA module facing the top side of the cassette.
 - Push the CA module without canting into the guide rails of the CA slot ④ and contact it to the common interface.

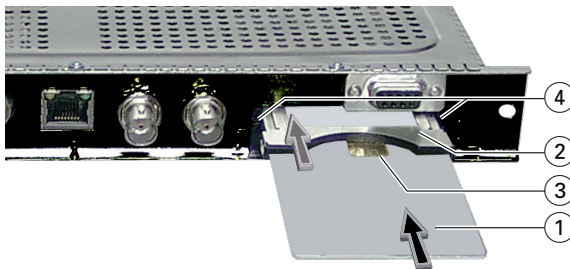

4 THE CONTROL PANEL AT A GLANCE

4.1 MENU ITEMS

Program the cassette using the buttons on the control unit of the head-end station. The two-line display of the control unit then shows the menus. The parameters and functions to be set are underlined.

Use the **MODE** button to select the following main menu items:

- Ethernet parameters
- Input signal path
- Output signal path
- Channel strip
- Transmission protocol, port number
- Number of data packets, forward error correction, transmission channel
- Output IP address
- LAN output data rate
- Input channel
- Station filter
- CA module (if available)
- Output data rate
- Network Information Table (NIT)
- Deleting a PID
- Renaming a PID
- Factory reset



4.2 CONTROL PANEL

The key pad on the head-end station is used to scroll through the menus:

- | | |
|--------------------|-------------------------------------|
| MODE | scrolls forward through the menus. |
| < / > | select parameters in the menus. |
| + / - | set values, initiate actions. |
| MULTI | selects sub-menus. |
| AUDIO | scrolls backward through the menus. |
| M | saves all entries. |



5 PROGRAMMING

5.1 PROGRAMMING PROCEDURE

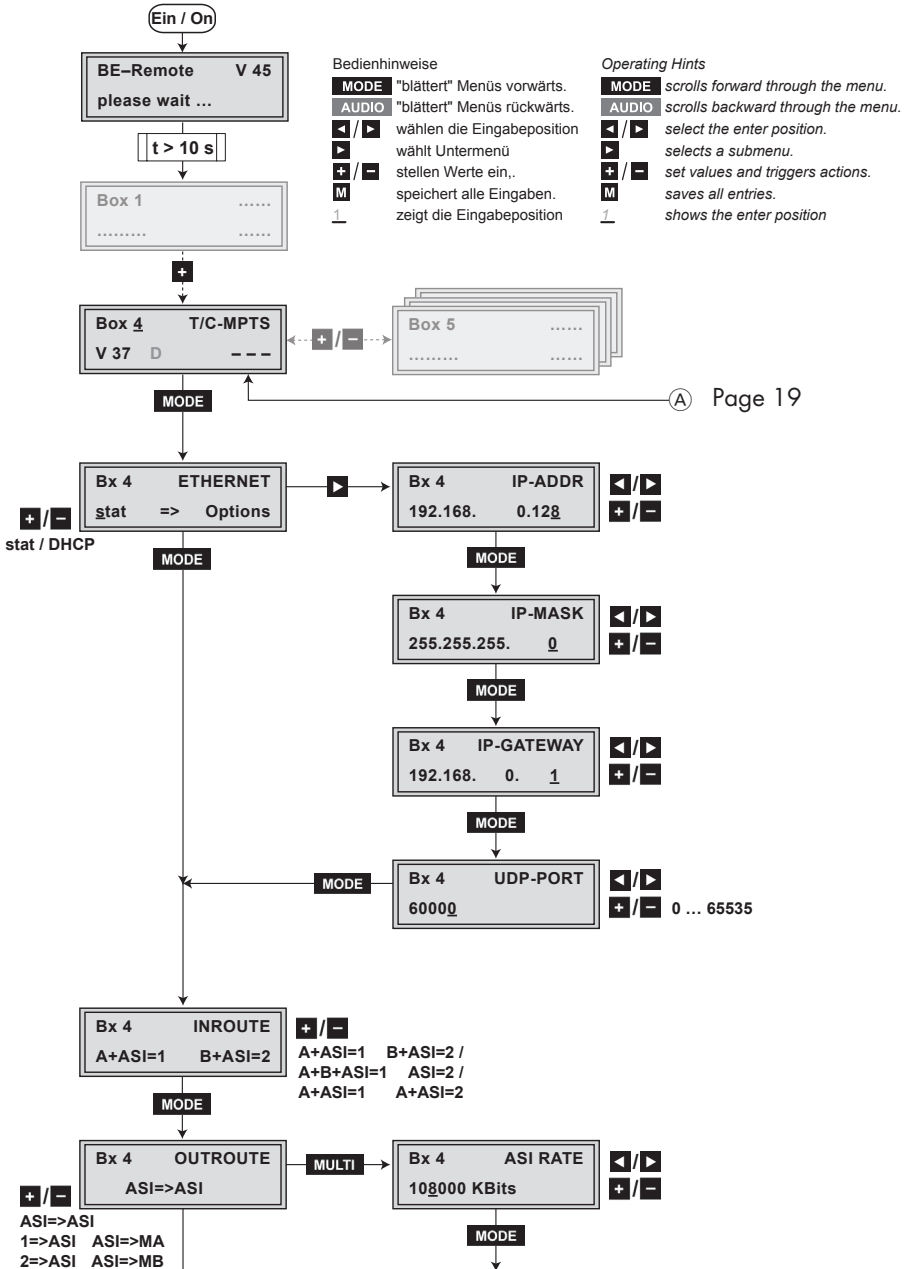

Bx 4 ASI OPTION
188 pos. cont.
188 / 204
positive / negative
continuous / burst

Page 19

MODE

Bx 4 LINE
Line A <= => Line B

Line A/Line B

Bx 4A/B MODE/PORT
on UDP _1234

on / off
UDP / RTP,
0 ... 65535

Bx 4A/B PKTS / FEC
Z off

off / 10/9 ... 20/19
Annex A / Annex B

+ / -
1 ... 7

Bx 4A/B OUT-IP
227. 40. 50. 60

OUT-IP

Bx 4A LAN RATE
!! auto

LAN RATE
auto / 2...80.0 Mbits

Bx 4A/B INPUT
COFDM 8MHZ

+ / -

QAM...
COFDM...

Bx 4A/B INPUT
C55 746.00 OK

+ / -

OK

Bx 4A/B PROGRAM
Filter off

PROGRAM
Filter
on -> off

abhängig von Einstellung INROUTE / dependent on setting INROUTE

Bx 4A TV ± 01/07
Das Erste

Bx 4B TV ± 01/09
ZDF

Services entfernen / hinzufügen
Removing / activating services

nächster Service (Programm)
next service (station)

Services entfernen / hinzufügen
Removing / activating services

nächster Service
next service

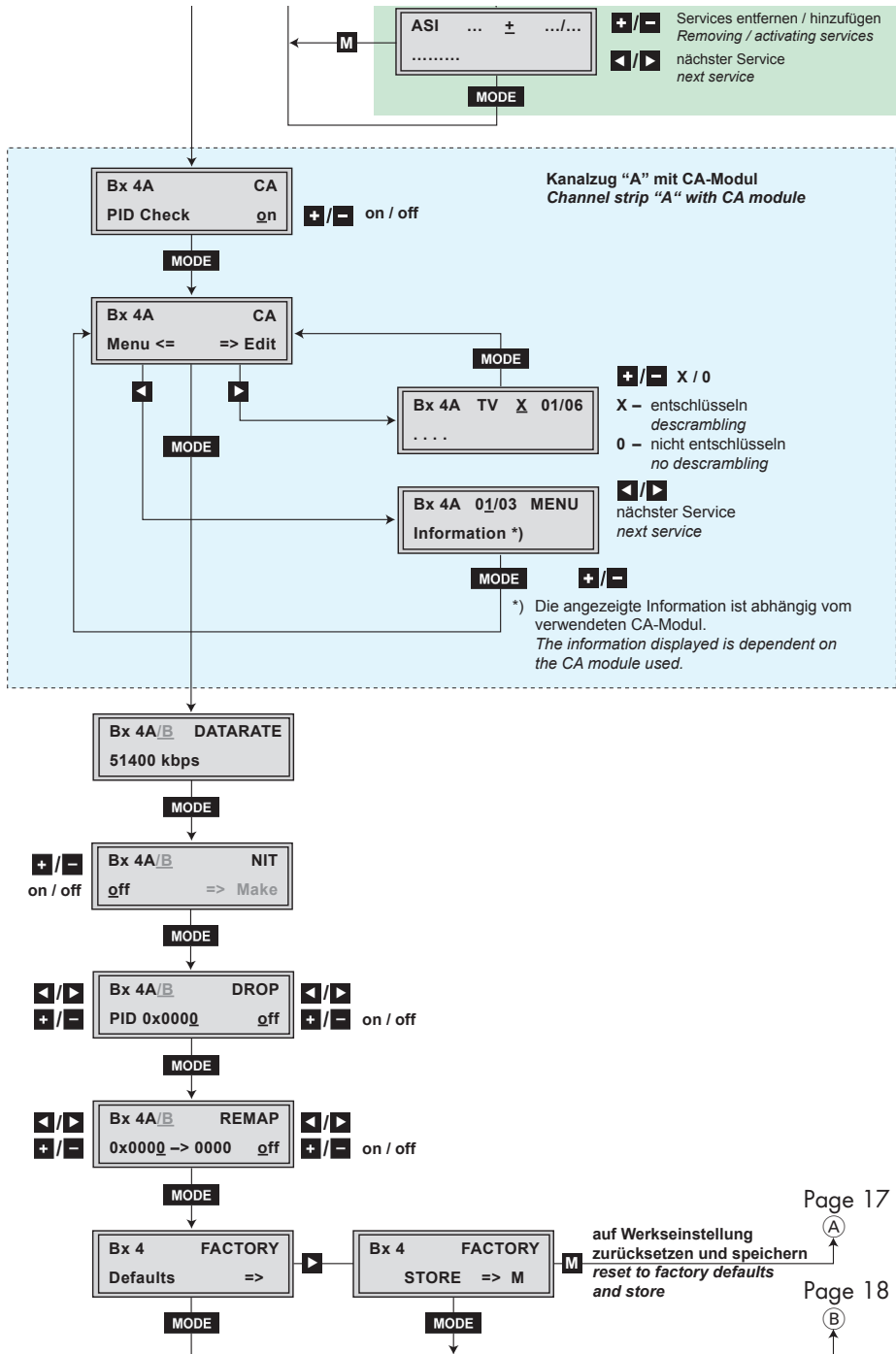

- Pressing the **MODE** button for longer than 2 seconds cancels the programming procedure. This takes you back to the program item "Selecting the cassette" from any menu. Any entries that have not been saved are reset to the previous settings.
- Entries in the menus can be saved by pressing the **M** key. You are taken back to the "Selecting the cassette" menu item.
- Pressing the **AUDIO** button returns to the previous menus.

- Switch on the head-end station

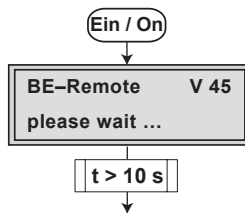

- The display shows the software version (e.g. V 45)
- The processor reads the cassettes' data (approx. 10 seconds).

SELECTING THE CASSETTE, DISPLAYING THE SOFTWARE VERSION

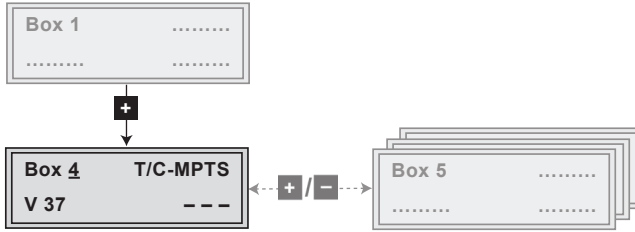

- Select the cassette you want to program (e.g. **Box 4**) by repeatedly pressing the button **+** if necessary.

→ The display shows e.g. the menu "**Box 4 T/C-MPTS**":
"Box 4" stands for slot 4
"T/C-MPTS" type of cassette
"V 37" software version of the cassette

- Press the **MODE** button.

→ The "Ethernet parameters" – "**ETHERNET**" menu is activated.

ETHERNET PARAMETERS

In this menu you specify whether the Ethernet parameters for the cassette are entered automatically by a connected server ("**DHCP**"), or whether you want to enter them manually ("**stat**"). To assign the cassette uniquely, each IPTV cassette must be allocated its own IP address.



- Press the **+**/**-** buttons to select manual setting ("**stat**") or automatic setting ("**DHCP**") of the Ethernet parameters.
- Press the **▶** button to activate the setting options ("**Options**").

→ The "IP address of the cassette" – menu "**IP-ADDR**" is activated.

IP ADDRESS OF THE CASSETTE

If you choose to enter the Ethernet parameters manually, set the IP address of the cassette in this menu. If "DHCP" is selected, the "IP-ADDR", "IP-MASK" and "IP-GATEWAY" sub-menus display the parameters that were assigned automatically by a connected server. If a server is not connected, " 0. 0. 0. 0*" appears in the corresponding menu. The star " * " in the display means that the data is provided by a DHCP server.

Bx 4	IP-ADDR
192.168.	0.128

- Use the ◀/▶ buttons to place the cursor under the digit of the IP address displayed to be set and use +/− to set the desired IP address.
- Press the **MODE** button.

→ The "Address range" – "IP-MASK" menu is activated.

ADDRESS RANGE

In this menu you define the address range for the cassettes connected to the LAN network.

Bx 4	IP-MASK
255.255.255.	0

- Use the ◀/▶ buttons to place the cursor under the digit of the IP address displayed to be set and use +/− to set the desired IP address.
- Press the **MODE** button.

→ The "Address of the gateway" – "IP-GATEWAY" menu is activated.

ADDRESS OF THE GATEWAY

The address of a gateway (server) can be set in this menu. If no gateway is used you can skip this setting.

Bx 4	IP-GATEWAY
192.168.	0. 1

- Use the ◀/▶ buttons to place the cursor under the digit of the IP address displayed to be set and use +/− to set the desired IP address.
- Press the **MODE** button.

→ The "UDP port" – "**UDP-PORT**" menu is activated.

UDP PORT

The UDP port setting is required if the cassette needs to be reached externally to make the setting, such as from another input frequency. This setting is intended for future functions and can be skipped for this cassette.

Bx 4	UDP-PORT
6000	

- Use the ◀/▶ buttons to place the cursor under the digit of the port number displayed to be set and use +/− to set the desired port number ("0" ... "65535").
- Press the **MODE** button.

→ The "Input signal path" – "**INROUTE**" menu is activated.

INPUT SIGNAL PATH

In this menu you define the signal path of the input transport streams.

Menu setting "A+ASI=1 B+ASI=2" (page 7).

Menu setting "A+B+ASI=1 ASI=2" (page 7).

Menu setting "A+ASI=1 A+ASI=2" (page 7).

Bx 4	INROUTE
A+B+ASI=1	ASI=2

- Use the **+**/**-** buttons to select the desired signal path.
- Press the **MODE** button.

→ The "Output signal path" – "**OUTROUTE**" menu is activated.

OUTPUT SIGNAL PATH

In this menu you define the signal path of the output transport streams.

Menu setting "ASI=>ASI" (page 8).

Menu setting "1=>ASI ASI=>MA" (page 8).

Menu setting "2=>ASI ASI=>MB" (page 8).

Bx 4	OUTROUTE
1=>ASI	ASI=>MA

- Use the **+**/**-** buttons to select the desired signal path.
- If you do not want to do ASI settings, press the **MODE** button.

→ The "Selecting the channel strip" – "**LINE**" menu is activated (page 26).

- Press the **MULTI** button.

→ The "ASI transfer rate" – "**ASI RATE**" menu is activated.

ASI TRANSFER RATE

In this menu you set the transfer rate for the ASI component connected.
For this setting please take the required information from the documentation (technical data) of the ASI component to be connected.

Bx 4	ASI RATE
108000	KBits

- Use the ◀/▶ buttons to place the cursor under the digits to be set for the transfer rate then use the +/− buttons to set the desired transfer rate.
- Press the **MODE** button.

→ The "ASI options" – "**ASI OPTION**" menu is activated.

ASI OPTIONS

In this menu you define the size of the data packets, their polarity and the type of transmission.

For this setting please take the required information from the documentation (technical data) of the ASI component to be connected.

Bx 4	ASI OPTION
188	pos. cont.

- Press the +/− buttons to set the size of the data packets ("188" or "204" bits).
- If the polarity of the data to be transmitted has to be changed, press the ◀/▶ buttons to place the cursor under "pos." (positive – standard) and using the +/− buttons set to "neg." (negative).
- To change the type of transmission press the ◀/▶ buttons to position the cursor under "cont." (continuous – standard) and using the +/− set to "burst".

→ Setting "cont."

The data packets of the user data are spaced out evenly in the transport stream.

—> Setting "**burst**"

The data packets of the user data are collected to a great data packet in the transport stream.



- Press the **MODE** button.

—> The "Selecting the channel strip" – "**LINE**" menu is activated.

SELECTING THE CHANNEL STRIP

In this menu select the channel strip for which the following settings have to be done.

Bx 4	LINE
Line A <=	=> Line B

- By pressing  select channel strip "**A**" ("**Line A**") or select channel strip "**B**" ("**Line B**") by pressing the  button.

—> The "Switching the IP address off or on, transmission protocol, port number" – "**MODE / PORT**" menu is activated.

SWITCHING THE IP ADDRESS OFF OR ON

TRANSMISSION PROTOCOL

PORT NUMBER

In this menu you can switch off or on the output IP address of the channel strip, and define the transmission protocol and the port number.

Bx 4A	MODE/PORT
on	UDP _1234

Switching the IP address off or on

- Press the  /  buttons to switch "**off**" or "**on**" the output IP address of the channel strip.

Selecting the transmission protocol

- Press the **▶** button to position the cursor under "UDP" or "RTP".
- Using the **+**/**-** buttons to select the desired transmission protocol:

- > "UDP" – The User Datagram Protocol is for the connectionless transmission of data to a certain application. The port number of the service is also sent which the data should obtain.
- > "RTP" – The Real-time Transport Protocol is for continuously transmitting multimedia data streams in an IP network. Unlike UDP, the header is transmitted which makes the data transmission more robust.

Setting the port number

- Press the **▶** button to position the cursor under the port number e.g. "_1234".
- Use the **◀**/**▶** buttons to position the cursor under the digit of the port number displayed to be set.
- Using the **+**/**-** buttons set the desired port number ("0" ... "65535").
- Press the **MODE** button.

- > The "Quantity of data packets, Forward error correction, Transmission channel" – "PKTS / FEC" menu is activated.

QUANTITY OF DATA PACKETS

FORWARD ERROR CORRECTION

TRANSMISSION CHANNEL

In this menu you set the quantity of the data packets to be transmitted, the forward error correction FEC and the transmission channel. If the forward error correction is used the data to be transmitted is encoded in a redundant way so that the addressee can correct transmission errors.

Bx 4A	PKTS / FEC
Z	off



Defining the quantity of data packets

- Using the **+**/**-** buttons define the quantity of MPEG data packets in one IP data packet ("1" ... "7").

Setting the forward error correction



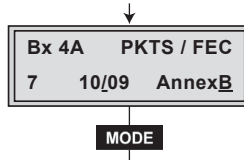

- Press the  button to position the cursor under "**off**".

—> In position "**off**" the forward error correction (FEC) is switched off.

- Using the  /  buttons set the desired value of the FEC ("**off, 10/9**" ... "**20/19**").



Setting the transmission channel

- Press the  button to position the cursor under "**Annex...**".
- Use the  /  buttons to set the desired transmission channel ("**AnnexA**" / "**AnnexB**").
- Press the  button.



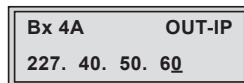

—> The "Output IP address" – "**OUT-IP**" menu is activated.

OUTPUT IP ADDRESS

In this menu you set the output IP address for the channel strip selected. To this IP address the desired services are allocated in the station filter.



—> Allocate different IP addresses to the channel strips.

- Press the  /  buttons to position the cursor under the digit of the IP address to be set.
- Using the  /  buttons set the desired IP address.
- Press the  button.

—> The "LAN data rate" – "**LAN RATE**" menu is activated.

LAN DATA RATE

In this menu you adjust the LAN output data rate.



- Press the **◀/▶** buttons to position the cursor under the digit of the data rate to be set.
- Using the **+/-** buttons set the desired data rate (2 MBit... 80 MBit, "auto").

—> The sum of the data rates of the lines A + B must not exceed 80 MBit

- Press the **MODE** button.

—> The menu "Input parameter" – **INPUT** is activated.

INPUT PARAMETER

In this menu you have to set the corresponding input parameters for the transponder to be received.

KIND OF MODULATION



- Using the buttons **+/-** select the corresponding kind of modulation of the transponder (COFDM 7MHz, COFDM 8MHz, QAM16...QAM256).

SYMBOL RATE

If "QAM..." modulation is selected, the setting for the symbol rate appears at the right side.

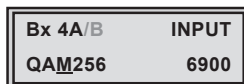





- Use the **◀/▶** buttons to position the cursor under the digit to be set for the symbol rate then use **+/-** to set the corresponding symbol rate.
- Press the **MODE** button.

→ The menu "Input channel / Input frequency" – "**INPUT**" is activated.

INPUT CHANNEL / INPUT FREQUENCY

In this menu you have to set the corresponding input channel / input frequency for the transponder to be received.

Bx 4A/B	INPUT
C55	746.00 OK

- Use the / buttons to position the cursor under the digit to be set for the input channel / input frequency then use / to set the desired input channel / input frequency.

→ Once the RF receiver has synchronised to the input signal, "OK" is displayed.

→ If "--" appears in the second line of the display, there is no input signal present. Check the configuration of the antenna system and the head-end station as well as the preceding settings of the cassette.

- Press the **MODE** button.

→ The "Station filter" – "**PROGRAM**" menu is activated.

STATION FILTER

The default setting for the station filter is "**off**". In this menu you define the services received to be transmitted. If services are activated the output data rate increases.

If the station filter is switched off (factory default) all services of the transport stream passes the station filter.



The figure of the menu below is dependent on the setting of the "Input signal path" "**INROUTE**" menu (page 24).

The programming procedure shown below corresponds to the setting "**A+B+ASI = 1 ASI = 2**".

With this setting the transport stream of channel strip "**B**" is routed to the transport stream of channel strip "**A**" and therefore cannot be set in channel strip "**B**". Programming channel strip "**B**" the transport stream coming from the ASI input can be processed only.

Channel strip "A"

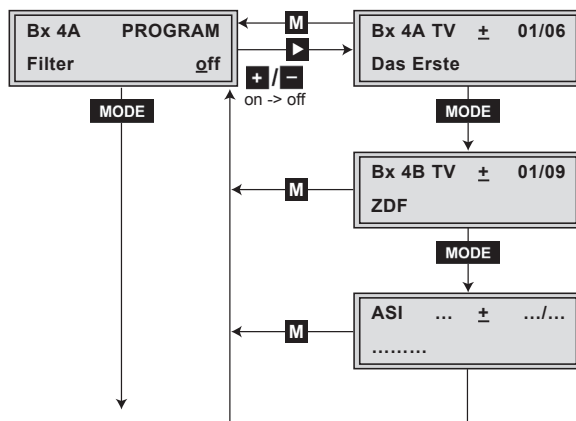

Channel strip "B"

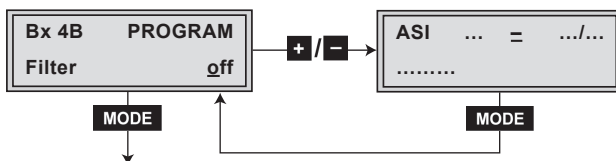

- Press the **+ / -** button.

→ All services from the channel strip will be read, and then displayed with name and type of the service.

→ If no services are found, the following error message will appear in the display: "**FILTER no Service**".

In this case, check the configuration of the antenna system and head-end station, as well as the previously adjusted settings for the cassette and the components connected to the ASI input.

→ The display shows e.g.: **Bx 4A TV + 01/06**
Das Erste

Meaning of the indicators in the example:

- "Bx 4A" Slot 4, channel strip "A"
- "TV" Type of service "Television"
- " + " The currently selected service is activated.
- "01/06" The 1st of 6 services is being displayed .
- "Das Erste" Name of the service

Further possible terms displayed:

"RA"	Type of the service "Radio" For radio stations, the background of the screen of the connected TV or test receiver is darkened.
" - "	The currently selected service is switched off.
" * "	The star means that the service selected is encoded. To enable the service, the CA module and the appropriate smart card of the provider are required.

—> If a service number (e.g. "131") appears instead of "TV" or "RA", this indicates that an unnamed service or an undefined transport stream is being received.

- Use the ◀/▶ buttons to call up the services in sequential order, then use +/- to activate (indicated by " + ") or to deactivate them (" - ").

—> Pressing the **MULTI** button all services can be activated or deactivated.

- Press the **MODE** button.
- Set the station filters of channel strip "B" and "ASI" in the same way as channel strip "A".
- To save changes and to activate the station filter press the **MODE** button.

—> The filter is activated.
The display shows "PROGRAM Filter on".
—> If services are activated the corresponding PIDs (audio, video, text) are inserted into the transport stream and the PAT and SDT tables are updated.

Test the status of the individual services:

- If the filter is switched on, press the ▶ button. In this mode you can test the settings of the station filter again or change them if necessary.
- In the "PROGRAM Filter on" menu the station filter switched on can be switched "off" using the buttons +/- if necessary.

"INROUTE" SETTING "A+ASI=1 B+ASI=2" AND "A+ASI=1 A+ASI=2"

Channel strip "A"

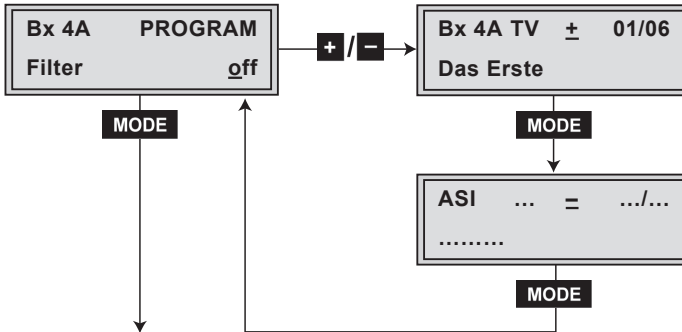

- Set the channel strip "A" or channel strip "B".

—> The setting of the channel strips "A" and "B" is identical and follows the description above.

- Press the **MODE** button.

—> The "Output data rate" – "DATARATE" menu is activated when the channel strips "A" without a CA module installed and "B" are programmed. Programming the channel strip "A" with a CA module installed the "PID monitoring" – "CA" menu is activated (page 37).

OUTPUT DATA RATE

In this menu the current data rate is displayed.

Bx 4A	DATARATE
72956 kbps	

- Press the **MODE** button.

—> The "Network Information Table" – "NIT" menu is activated.

NETWORK INFORMATION TABLE (NIT)

The cassette outputs a generated NIT via LAN, if NIT is switched on.

Bx 4A	NIT
off	=> Make

- To switch NIT on/off ("on"/"off") press the **+**/**-** buttons.
- Using button **▶** (=>"Make") you can generate a NIT.



→ IF you generate a NIT using the menu "NIT" of any cassette, all channels received via the PCIM 1000 will **not** be included. If you would like to modulate these channels e.g. to a DVB-C transponder later on, you can manually add this transponder "in advance" to the NIT via the PSW 1000 software. Therefore observe the operating instruction of the PSW 1000.

For all cassettes able to output a NIT:

→ All these cassettes must be set and ready for reception.
→ The NIT of all cassettes are switched on.
→ The cassette fetches all the information (output frequencies, output symbol rates, etc.) it needs from all cassettes in order to generate the cable NIT. This process may take a few seconds.
Then the NIT is generated, added and sent to all cassettes. The other cassettes also add this new cable NIT. The status of all cassettes in the NIT menu changes to "on".
The display shows: "**read ... / copy ...**".

- To switch off the new NIT ("off") press the **-** button.



→ The NITs of the other cassettes will stay switched on. When the NIT of the cassette is switched on again ("on") by pressing the **-** button, the previously generated NIT is added again. If you have changed parameters in the meantime, you must first select "**Make**" to generate a new, up-to-date NIT.

- Press the **MODE** button.

→ The "Deleting a PID" – "**DROP**" menu is activated.

DELETING A PID

In this menu a PID of the transport stream can be deleted.

Bx 4A	DROP
PID 0x0000	off

- Use the **◀/▶** buttons to place the cursor under the respective digit of the hexadecimal number of the PID to be deleted ("0x0000") and set the hexadecimal number using **+/-**.
- Use **▶** to set the cursor to "off" and switch to "on" (delete) using the **+/-** buttons.
- Press the **MODE** button.

—> The "Renaming a PID" – "REMAP" menu is activated.

RENAMING A PID

In this menu you can allocate a new address to a PID retaining the complete data content.

Bx 4A	REMAP
0x0000 -> 0000	off

- Use the **◀/▶** buttons to place the cursor under the respective digit of the hexadecimal number of the PID to be changed ("0x0000") and set the hexadecimal number using **+/-**.
- Use the **◀/▶** buttons to place the cursor under the respective digit of the hexadecimal number of the new PID ("-> 0000").
- Set the hexadecimal number using **+/-**.
- Use **▶** to set the cursor to "off" and switch to "on" (rename) using the **+/-** buttons.
- Press the **MODE** button.

—> The "Factory reset" – "FACTORY Defaults" menu is activated.

FACTORY RESET

In this menu you can reset all settings to the factory defaults.

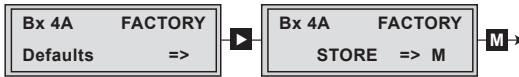

- Press the **▶** button.

—> The factory defaults are invoked ("FACTORY STORE").
—> By pressing the **MODE** button, you will be returned to the menu item "Selecting the channel strip" **without** invoking the factory defaults (page 26).

- Press the **M** button.

—> The factory defaults are saved. The display shows "STORE"
—> Back to "Selecting the cassette" (page 21).
—> By pressing the **MODE** button, you will be returned to the menu item "Selecting the channel strip" **without** saving the factory defaults (page 26).
—> If necessary set channel strip "B".

SAVING SETTINGS

- Press the **M** button.

—> Back to "Selecting the cassette" (page 21).
—> The settings are saved.
—> If functions of the TPS module are activated, their status is shown in the second line of the display:
"M" – Station filter is switched on.
—> By pressing the **MODE** button, you will be returned to the menu item "Selecting the channel strip" **without** saving the programmed data (page 26).
—> If necessary set channel strip "B".

OPERATION WITH A CA MODULE

In order for this function of the CA module to be possible, in the "Station filter" – "**PROGRAM**" menu (page 30) services must be selected which can be descrambled by the CA module you are using and your smart card. Where both scrambled and unscrambled services are transmitted, short-term picture loss may occur when switching between scrambled and unscrambled services.

PID MONITORING

The factory default of the PID monitoring is switched on.

If particular PIDs are not descrambled the CI module is reset. Additionally dropouts may occur if several services are descrambled. To prevent this the PID monitoring can be switched off.

Bx 4A	CA
PID Check	on

- Use the **+**/**-** buttons to switch "**off**" or "**on**" the PID monitoring.
- Press the **MODE** button.

—> The "CA module" – "**CA**" menu is activated.

CA MODULE

The menu varies according to which CA module you are using. For this reason, please refer to the operating manual of your particular CA module. The relevant information is shown in the display of the head-end station. This may appear as a fixed display or as scrolling text according to display capabilities.

Bx 4A	CA
Menu <=	=> Edit

—> By pressing the **MODE** button you can skip the "CA module" – "**CA**" menu and activate the "Output data rate" – "**DATARATE**" menu (page 33).

- Press the **◀** button to activate the "**MENU**" menu of the CA module.

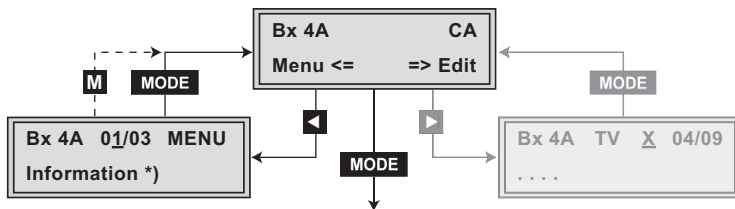

—> The display shows e.g.: **Bx 4A 01/03 MENU**
Information

Meaning of the indicators:

- "Bx 4A" Slot 4, channel strip "Tuner A"
- "01/03" The first of three menu items is activated.
- "MENU" The menu of the CA module is activated.

For the explanation of further details please use the operating instructions of the CA module used.

- Use the **+**/**-** buttons to activate the menu desired.
- Press the **▶** button to activate the menu.
- Use the **+**/**-** buttons to select the function desired.
- To set the CA module use the **◀**/**▶** and **+**/**-** buttons.
- All settings are saved by pressing the **M** button.

—> You will be returned to the "CA module" – "CA" menu item.
—> By pressing the **MODE** button you can cancel the settings in the menu of the CA module and are returned to the "CA module" – "CA" menu.

- Press the **▶** button.

—> The "Descrambling services" – "Edit" menu is activated.

DESCRAMBLING SERVICES

In this menu you select the desired services from the scrambled input transport stream, which are to be descrambled.

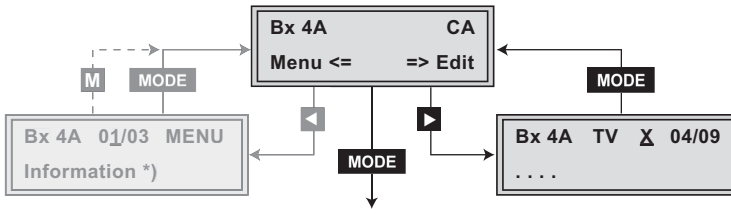

→ The display shows e.g.: **Bx 4A TV X 04/09**

....

Meaning of the indicators in the example:

- "Bx 4A" Slot 4, channel strip "A"
- "TV" "Television" (type of service)
- "X" Descrambling is set for the currently selected station.
- "04/09" The 4th of 9 services is being displayed.
- ". . . ." Name of the service

Further possible terms displayed:

- "RA" "Radio" (type of service)
- "0" The currently selected service remains unchanged.

- Use the ◀/▶ buttons to call up the services in sequential order which are to be decoded, then use +/− to decrypt ("X") or not to decrypt them ("0").
- Press the **MODE** button to save changes and activate the filter.

→ The filter is activated.

The display shows the "CA module" – "CA" menu.

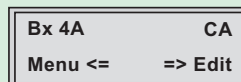

- Press the **MODE** button.



→ The "Output data rate" – "DATARATE" menu is activated (page 33).



After installing the head-end station, upgrading accessories or installing cassettes it is necessary to tighten all cable connections, cable terminals and cover screws in order to maintain compliance with current EMC regulations securely.

- Securely tighten the cable bolted connections fingertight using an appropriate open-ended spanner.
- Mount the front cover (see assembly instructions of the head-end station).

Declaration of CE conformity

	Konformitätserklärung Declaration of Conformity 013/ 14																					
<p>Der Hersteller/Importeur The manufacturer/importer</p>																						
<p style="text-align: center;">GSS Grundig SAT Systems GmbH</p>																						
<p>Anschrift / Address / Adresse Beuthener Straße 43, D-90471 Nürnberg, Germany</p>																						
<p>erklärt hiermit eigenverantwortlich, daß das Produkt: declare under their sole responsibility that the product:</p>																						
<p>Bezeichnung / Name / Description Head-End HDTV Converter to IP DVB- C / T → MPTS</p>																						
<p>Type / Model / Type GSS PCIM 1000</p>																						
<p>Bestell-Nr. / Order-No. GAP 5700</p>																						
<p>folgenden Normen entspricht: is in accordance with the following specifications:</p>																						
<table style="width: 100%; border: none;"> <tr> <td style="width: 33%;"><i>EN 50083-2:</i></td> <td style="width: 33%;">2012</td> <td style="width: 33%;"><i>EN 60065:</i></td> <td style="width: 33%;">2002</td> </tr> <tr> <td><i>ETSI EN 300386 :</i></td> <td>2010</td> <td><i>EN 60065 + A1:</i></td> <td>2006</td> </tr> <tr> <td><i>EN 50581 :</i></td> <td>2012</td> <td><i>EN 60065 + A11:</i></td> <td>2008</td> </tr> <tr> <td></td> <td></td> <td><i>EN 60065 + A2:</i></td> <td>2010</td> </tr> <tr> <td></td> <td></td> <td><i>EN 60065+ A12:</i></td> <td>2011</td> </tr> </table>			<i>EN 50083-2:</i>	2012	<i>EN 60065:</i>	2002	<i>ETSI EN 300386 :</i>	2010	<i>EN 60065 + A1:</i>	2006	<i>EN 50581 :</i>	2012	<i>EN 60065 + A11:</i>	2008			<i>EN 60065 + A2:</i>	2010			<i>EN 60065+ A12:</i>	2011
<i>EN 50083-2:</i>	2012	<i>EN 60065:</i>	2002																			
<i>ETSI EN 300386 :</i>	2010	<i>EN 60065 + A1:</i>	2006																			
<i>EN 50581 :</i>	2012	<i>EN 60065 + A11:</i>	2008																			
		<i>EN 60065 + A2:</i>	2010																			
		<i>EN 60065+ A12:</i>	2011																			
<p>Das Produkt erfüllt somit die Forderungen folgender EG-Richtlinien: Therefore the product fulfils the demands of the following EC-Directives:</p>																						
<p>2006/95/EG</p>	<p>Richtlinie betreffend elektrische Betriebsmittel zur Verwendung innerhalb bestimmter Spannungsgrenzen Directive relating to electrical equipment designed for use within certain voltage limits</p>																					
<p>2004/108/EG</p>	<p>Richtlinie über die elektromagnetische Verträglichkeit Directive relating to electromagnetic compatibility</p>																					
<p>2011/65/EG</p>	<p>Richtlinie zur Beschränkung der Verwendung bestimmter gefährlicher Stoffe in Elektro- und Elektronik Altgeräten Directive on the restriction of the use of certain hazardous substances in electrical and electronic equipment</p>																					
<p>Nürnberg, 9. Dezember 2014</p>																						
<div style="text-align: right;">  Michael Bierschneider Leiter Entwicklung Manager Development / Directeur Développement </div>																						

Service:

Phone: +49 (0) 911 / 703 2221

Fax: +49 (0) 911 / 703 2326

Email: service@gss.de