



**HDMI**<sup>TM</sup>  
HIGH DEFINITION MULTIMEDIA INTERFACE

**Full HD**  
**1080P**

**HDCP**  
COMPLIANT

**3D**

## WyreStorm SDI Extender Solutions

## EX-SDI-50

50m/164ft HDMI over SDI Cascading Extender with Bidirectional IR Control & RS232

## Instruction Manual



Thank you for choosing this WyreStorm product.  
Please read these instructions carefully before installing to avoid complications later.

# Contents

- 1** Introduction
- 2** Features
- 3** Safety Precautions
- 4** Package Contents
- 5** Specification
- 6** Panel Descriptions
- 7** Typical Application
- 8** Copper Core 75Ohm WF100 Coax Cable Distance
- 9** Initial Connection & Basic IR Control
- 10** IR/RS232 Control Connection
- 11** Update RS232 Settings
- 12** RS232 Connection
- 13** EDID & SETTING Management
- 14** Troubleshooting
- 15** FAQs
- 16** Maintenance
- 17** Product Service
- 18** Mail In Service
- 19** Warranty
  - i. Warranty Limits and Exclusions
- 20** Installation Notes

# 1. Introduction

**The WyreStorm EX-SDI-50 is single cable HDMI over SDI cascading point-to-point extender set capable of transmitting lossless 1080p HD video@60Hz and multi-channel HD audio up to 50m (164ft) using copper-core 75Ohm WF100 coax cable.**

Comprising of a transmitter and receiver, the EX-SDI-50 features full 3D compatibility and 24bit True Color with wide-band, two-way control from either source or display location via IR and RS232 with full support for leading third party control systems.

The EX-SDI-50 is designed for residential or ProAV applications where use of coax to distribute and control HD signals is either required due to retrofit installations where existing coax cabling infrastructure must be used, or preferred for its low loss at high frequencies; vital for cable/satellite television, cable modem installations as well as commercial applications such as security/surveillance, broadcast television and film production in studio or location, video conferences, electronic teaching, in fact, any and wired network area where the extension and amplification of SDI transmission is needed.

Featuring twin synchronous SDI outputs on the EX-SDI-50 transmitter, a signal can be sent in two different directions to create a cascable splitting system feeding different locations by pairing a single transmitter with multiple receivers, with a SDI loop out on each receiver enabling the daisy-chaining of several receivers to create larger, multi-location distributions. (additional receivers sold separately)

The EX-SDI-50 fully supports 3D transmission and includes embedded EDID functionality to manage the EDID handshake between devices to aid communication and help avoid compatibility issues that can effect successful signal transmission.

For further information on this product and other WyreStorm ranges, visit our website or download our latest product guide. [www.wyrestorm.com](http://www.wyrestorm.com)

## 2. Features

- Single coax cable as a substitute for HDMI cable to achieve scaleable long-distance transmission of full HD video, audio and two-way control
- Full HD support 1080p@50/60Hz
- 1080p transmission distance up to 50m/164ft (WF100 coax cable) under perfect conditions\*
- 24bit colour depth
- Fully 3D compatible - frame packing/sequential (Blu-Ray), interlaced stereoscopic (satellite/cable broadcasts)
- Wide-band, bidirectional infrared control signal of source from display and display from source locations transmitted together with the HDMI signal
- RS232 control signal transmissions supported
- Dual SDI outputs on transmitter provides two synchronous feeds that enables signal to be split and fed to different locations
- SDI loop out on receiver allows transmission to be cascaded by daisy-chaining up to 7 receivers to further lengthen distribution from a single output distances up to 350m/1148ft or 700m/2296ft from both transmitter synchronous outputs.
- EDID management on transmitter / DIP Setting on receiver to assist communication between source/display and avoid compatibility issues
- HDMI V1.4 supported
- Each port supports HDMI or DVI signals
- Auto-adjustment of feedback, equalization and amplification
- HDCP compliant
- LED indication of power and signal status
- Contains ESD protection technology to safeguard against static build-up that can damage circuitry
- Mini-USB port for firmware upgrade
- Units can be cascaded up to 7 times to create larger distributions
- Mounting brackets supplied for secure installation
- IR emitter, receiver and 5v mains power supply included

**\*Perfect transmission conditions denote - straight cable run within specified distance range of product, no electrical interference and the use of solid copper core cable with no bends, kinks or mid-run connections.**

**Please be advised that the presence of any of these factors in your installation may compromise bandwidth and signal strength.**

## 3. Safety Precautions



### WARNING

To reduce the risk of fire, electric shock or product damage:

1. Do not expose this apparatus to rain, moisture, sprays, drips or splashes and ensure that no objects containing liquids are placed on the apparatus, including cups, glasses and vases.
2. Do not place this unit in a confined space such as enclosed shelving, cabinets or bookshelves. Ensure the unit is adequately ventilated.
3. To prevent the risk of electric shock or fire hazard due to overheating, do not cover the unit or obstruct ventilation openings with material, newspaper, cardboard or anything that may restrict airflow into the unit.
4. Do not install near external heat sources such as radiators, heat registers, boilers or any device that produces heat such as amplifiers or computers and do not place near sources of naked flame.
5. Unplug apparatus from power supply during lightning storms or when unused for long periods of time.
6. Protect the power cable from being walked on, pinched or restricted in any way, especially at plug connections.
7. Only use attachments/accessories specified by the manufacturer.
8. Units contain non-servicable parts - Refer all servicing to qualified service personnel.

## 4. Package Contents

- 1 x TX-SDI-50 Transmitter
- 1 x RX-SDI-50 Receiver
- Printed user manual (**also downloadable from product web page**)
- 2 x 5V/3A DC power supplies (1 per unit)
- 1 x IR TX emitter - for source connection
- 1 x IR RX receiver - for display connection (30-50KHz)

## 5. Specification

Operating Temperature Range	-5 to +35°C (-41 to +95 °F)
Operating Humidity Range	5 to 90 % RH (no condensation)
Input / Output	Transmitter: 1 x HDMI Output, 2 x SDI output Receiver: 1 x HDMI Output, 1 SDI Input, 1 SDI loop Output
Bandwidth Signalling Rate	6.75Gbps
Input Resolution Support	1080p/1080i/720p/576p/480p/576i/480i
Input Video Signal	0.5-1.0 volts p-p
Input DDC Signal	5 volts p-p (TTL)
Output Signal Type	HDMI v1.4 + HDCP with full 3D compatibility with frame packing/sequential (Blu-ray) and interlaced stereoscopic (satellite/cable broadcasts)
Output Resolution Support	1080p/1080i/720p/576p/480p/576i/480i
Video Format Supported	DTV/HDTV: 640x480p 60Hz, 800x600 60Hz, 1024x768 60Hz, 1280x768 60Hz, 1360x768 60Hz, 1280x960 60Hz, 1280x1024 60Hz, 1400x1050 60Hz, 1440x480i 60Hz, 720x480p 60Hz, 1440x576i 50Hz, 720x576P 50Hz, 1440x576P 50Hz, 1280x720p 50Hz/60Hz, 1920x1080i 50/60Hz, 1920x1080p 24/25/30/50/60Hz, 1280x720p 3D 50/60Hz, 1920x1080i 3D 50/60Hz, 1920x1080p 3D 24Hz
Audio Format Supported	5.1/7.1/stereo audio (Including PCM and non PCM, HD Audio, etc)
Maximum Pixel Clock	148.5 MHz (1080p)
Power Supply	5V/3A DC
Power Consumption	7.5W (TX-SDI-50 Transmitter) 8W (RX-SDI-50 Receiver)
BTU Rating (British Thermal Unit)	N/A
ESD Protection	±8kV (Air-gap discharge) ±4kV (Contact discharge)
Surge Protection	IEC 61000-4-4 (EFT) 40A (5/50ns); IEC 61000-4-5 (Lightning) 25A (8/20µs)
Dimensions	118mm / 4.6" (W) 157mm / 6.2" (D) 25mm / 1.0" (H)
Weight	0.92Kg / 2.02lb (Pair)

**NOTE** Specifications are subject to change without notice. Weight and dimensions are approximate.

## 6. Panel Descriptions

### Transmitter

- |  |  |
|--|--|
| <b>1</b> Power input 5V/3A DC                  | <b>7</b> EDID switch                         |
| <b>2</b> LED Power indicator                   | <b>8</b> USB port for firmware upgrade       |
| <b>3</b> RS232 port                            | <b>9</b> IR TX emitter for source connection |
| <b>4</b> HDMI input                            | <b>10</b> SDI output 1                       |
| <b>5</b> LED HDMI input status indicator       | <b>11</b> SDI output 2                       |
| <b>6</b> IR RX receiver for display connection |  |

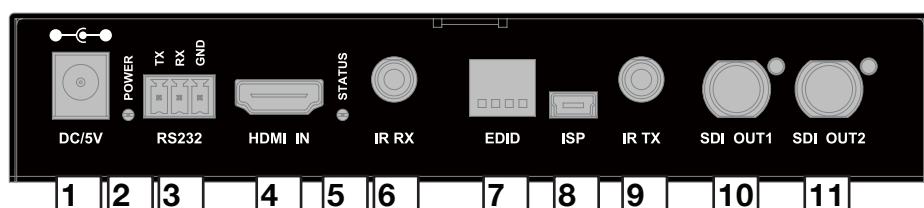

### Receiver

- |  |   |
|--|---|
| <b>1</b> SDI input                             | <b>7</b> LED SDI input status indicator |
| <b>2</b> SDI loop output                       | <b>8</b> HDMI output                    |
| <b>3</b> IR TX emitter for source connection   | <b>9</b> RS232 port                     |
| <b>4</b> EDID switch                           | <b>10</b> Power input 5V/3A DC          |
| <b>5</b> IR RX receiver for display connection | <b>11</b> LED Power indicator           |
| <b>6</b> USB port for firmware upgrade         |   |

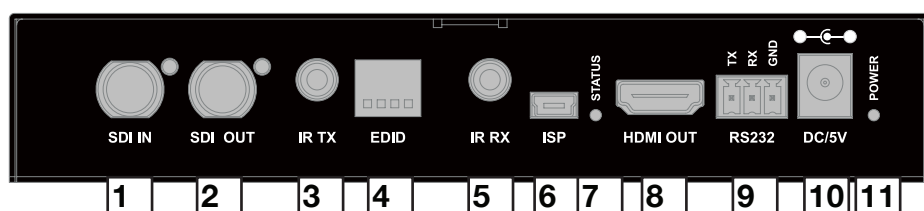

## 7. Typical Application

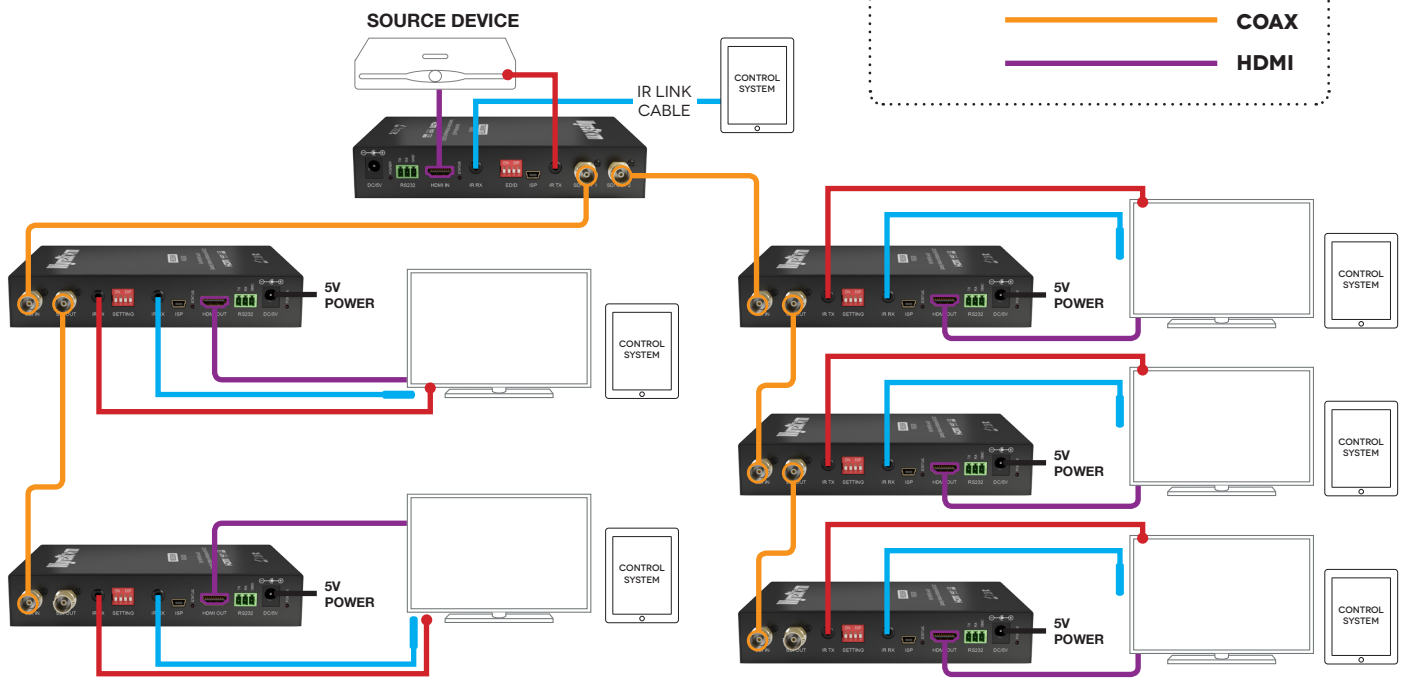

## 8. Copper Core 75Ohm WF100 Coax Cable Distance



### Coaxial Wiring Guide

The quality of termination for every BNC is

essential. Poor terminations leads to intermittent performance and longer install times.

Coaxial Cable Performance Guide											EX-SDI-50
0m	10m	20m	30m	40m	50m	60m	70m	80m	90m	100m	
0ft	32ft	65ft	98ft	131ft	164ft	197ft	230ft	262ft	295ft	328ft	

## 9. Initial Connection & Basic IR Control

- 1** Firmly connect a HDMI source device (such as Blu-Ray, games console, satellite/cable, media server, splitter or matrix etc.) to the HDMI IN of the TX-SDI-50 transmitter.
- 2** Connect a good quality, well terminated copper-core 75Ohm WF100 coax cable of no more than 50m/164ft in length between either of the synchronous SDI OUT ports on the TX-SDI-50 to the SDI IN port of the RX-SDI-50 Receiver.

**NOTE** If using both SDI OUT ports of the TX-SDI-50, an RX-SDI-50 receiver must be used for each output.

**Attention** 50m/164ft is the maximum recommended transmission distance over coax using this SDI equipment and denotes perfect transmission conditions - including straight cable runs with no electrical interference, bends, kinks and joins etc. If any of the above are a factor in your installation, transmission range may be affected – take care to avoid where possible.

- 3** Firmly connect the HDMI sink (LCD/LED/Plasma display / digital projector) to the HDMI OUT of the RX-SDI-50 receiver.

**NOTE** We strongly recommend using the supplied mounting brackets to secure both transmitter and receiver. Any sudden movement of devices can lead to loss of picture/sound if connections become loose or strained, resulting in unnecessary service call backs.

**4** For control of the source from display zone, connect the IR TX emitter from the TX-SDI-50 transmitter to the infrared receiver window of the source using the adhesive backing - you may need to adjust the position of the emitter eye on the source for best results.

When happy with the placement, press down firmly to ensure secure attachment of the emitter to the source.

**HINT** You can locate the IR sensor of devices by shining a flashlight onto the front of the device - the sensor should be a small round diode located behind the fascia. If in doubt, please consult the device manufacturer handbook.

**5** At the display zone, connect the IR RX receiver cable from the RX-SDI-50 receiver to the display, ensuring clear line of IR sight with the remote handset used to control. We recommend discrete placement of the IR RX eye using the adhesive backing, pressing down firmly to secure attachment.

**6** If daisy-chaining receivers, connect another coax cable of no more than 50m/164ft in length from the SDI OUT port of the RX-SDI-50 receiver to the SDI IN of another RX-SDI-50 receiver unit to enable signal pass-through.

**NOTE** RX-SDI-50 receivers can be cascaded up to 7 times along a single output.

**7** Connect the 5V DC power supplies included to both TX-SDI-50 and RX-SDI-50 and power on source, transmitter, receiver and display.

**8** Ensure the POWER and STATUS indicators are lit on both transmitter and all receivers used to confirm all units are powered and a signal is being passed between them.

**Attention** If you fail to receive a signal, check LED indicators are lit before checking power supply, all attached cables and source/display devices for correct connection and operation.

## 10. Bidirectional IR/RS232 Control Connection

**1** For bidirectional control of the source from display zone and display from source zone, connect the IR TX emitter from the TX-SDI-50 transmitter to the infrared receiver window of the source using the adhesive backing - you may need to adjust the position of the emitter eye on the source for best results. Ensure emitter is firmly attached over IR sensor - we recommend pressing down firmly to secure the adhesive backing.

**HINT** If unsure of positioning, IR sensors can be located on devices by shining a flashlight onto the fascia of the device - the IR sensor should be identifiable as a small round sensor behind the panel. If in doubt, please consult the device manufacturer handbook.

**2** If using an RS232-based control system, connect an IR Link Cable from the IR RX port of the TX-SDI-50 transmitter to your control system and insert cables into the RS232 ports to enable serial control.

**3** At the display zone, connect the IR RX receiver cable between the RX-SDI-50 receiver and the display, ensuring clear line of IR sight with the remote handset used to control. We recommend discrete placement of the IR RX eye on the display, pressing down firmly using the adhesive backing.

**4** Connect an IR TX emitter from the RX-SDI-50 receiver to the infrared receiver window of the display device using the adhesive backing - again, the position of the emitter may need to be adjusted for best results. Ensure emitter is firmly attached over IR sensor - we recommend pressing down firmly to secure the adhesive backing.

# 11. Update RS232 Settings

- 1** To update firmware for your device, simply connect a Serial-to-mini USB cable from the ISP port of the TX-SDI-50 / RX-SDI-50 to a computer
- 2** Run VS010 R X Firmware Update batch file.
- 3** When complete, remove the Serial-to-mini USB cable

**NOTE** Devices will not transmit or receive signals while updating firmware.

# 12. RS232 Connection

To allow serial commands to be sent between transmitting and display devices, simply connect serial cables between your control system and your display via the phoenix ports on the SDI extender set.

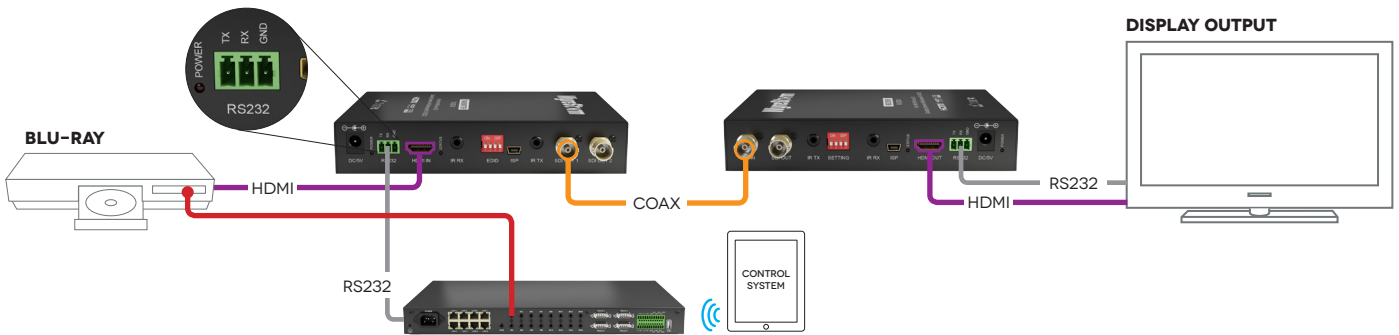

# 13. EDID & SETTING Management

Distribution of HD signals through devices requires mutual communication or 'handshake' between source and display. If there is any disparity between the two, successful transmission becomes problematic.

The EX-SDI-50 extender set comes equipped with EDID management on the TX-SDI-50 transmitter and additional SETTINGS on the RX-SDI-50 to encourage communication between INPUT and OUTPUT devices.

If compatibility or transmission issues arise during installation, check the settings on your connected devices and adjust the DIP settings as required.

**Attention** Changes to DIP settings become effective upon powering ON the units. Changes to settings should be made with all devices OFF, ideally with all power cables and HDMI leads and coax cables removed to guard against electrostatic build up that may damage your system.

**DO NOT HOTSWAP your cables when changing DIP SETTINGS.**

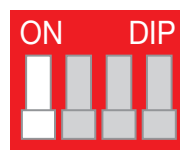

**Transmitter (DEFAULT) Video Auto-Mode (recommended setting):** SDI signal automatically detected and bypasses output, non-SDI signals processed by FPGA

**Receiver**

**(DEFAULT) Audio Auto-Mode (recommended setting)** SDI audio (PCM 48k) signal automatically detected and bypasses output, non-SDI signals processed by FPGA

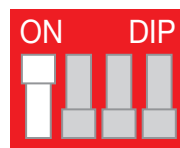

**Transmitter Process Mode (not recommended):** any connected source processed by FPGA, regardless of signal

**Receiver**

**Process Mode (not recommended):** any connected source processed by FPGA, regardless of signal

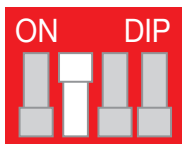
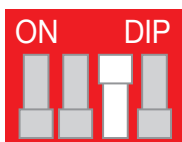
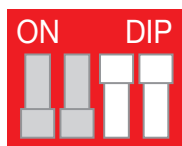
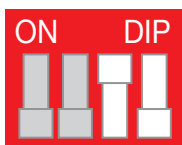
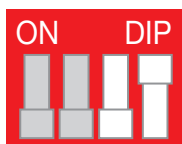
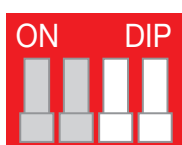

**Transmitter****EDID Copy Trigger (Note 1)****Receiver****Non-encryption Output:** disables HDCP signal encryption output**Transmitter****(DEFAULT) 1080P Stereo EDID / EDID Copy Trigger (Note 1)****Receiver****(DEFAULT) Output HDCP:** dictated by sink device**Transmitter****Reserved for future use - no function****Receiver****Color Detect Mode:** colour depth dictated by sink device**Transmitter****Reserved for future use - no function****Receiver****(DEFAULT) 24bit Color Output****Transmitter****EDID Copy:**copies EDID from sink device to the input port. **Note:** EDID Copy Trigger mode must be activated for this function**Receiver****Reserved for future use - no function****Transmitter****1080p 3D video, 7.1 Audio EDID****Receiver****Reserved for future use - no function****Transmitter****1080p video, 7.1 Audio EDID****Receiver****Reserved for future use - no function****Transmitter****(DEFAULT) 1080p 3D video, Stereo Audio EDID****Receiver****Reserved for future use - no function****Note1:**

(DEFAULT) 1080p stereo EDID is the factory default setting (OFF). Switching to ON activates the EDID COPY TRIGGER mode, which sends a command to the MCU for the Transmitter to copy EDID from the Receiver.

**Note:** this is not an 'Auto-copy' setting

Following an initial change of setting to the ON position, returning the switch to OFF will not return to DEFAULT 1080p Stereo EDID. Instead, both ON and OFF positions will 'Trigger' the command to be sent to the MCU for the Transmitter to copy EDID from the receiver. Toggling between settings will resend the trigger command to copy EDID.

To reset to 1080p Stereo, connect a display set to output 1080p 2CH audio and trigger the EDID Copy or change EDID DIP settings to 1080p 3D Stereo EDID.

## 14. Troubleshooting

**Generally, the majority of HD distribution installation issues are either caused by minor connection errors, communication problems between devices, or when the transmission of high signal bandwidth is attempted using insufficient cable. Should you encounter any technical difficulties when installing and configuring the matrix, we are confident solutions can be found by working through the following troubleshooting checklist before seeking alternative technical support.**

### No Picture or Poor Quality Picture

**1) Power** – are your SDI transmission and receiving devices powered with correct LED indication? All units should have their own power source connected ie. 5v for most 50m/164ft for SDI devices – Please use power supplies included.

Are all sources definitely powered and firmly connected?

**2)** If possible, always use test equipment prior to installation and to troubleshoot any problems. See WyreStorm system testing range at [www.wyrestorm.com](http://www.wyrestorm.com)

**3)** Check sink device supports HDCP, is switched to the correct source in/out mode and is compatible with the receiver - if any issue is suspected, replace sink device with another model.



**4) Distance** – Is the cable too long for the signal to be transmitted effectively? The transmission technology used within the transmitters and receivers allows 1080p up to 50m/164ft so make sure the cable distance matches the project requirements and is well within the maximum transmission distance of the signal.

**Note:** If approaching the limits of the transmission capabilities, transmission should be extended by using another extender set to ensure the signal reaches its destination effectively.

**5) Cable Joins** – Joins in the cable run or coax connectors can impact on signal strength, resulting in reduced transmission that may manifest itself in incorrect picture quality, picture dropping out or a complete lack of picture

**6) Cable Choice and Signal Reduction** – Are stranded patch leads being used as interconnects between patch panels or wall outlets? CCA (Copper Clad aluminium) cables being used? These can reduce transmission rates by up to 40% – we recommend solid core straight through with minimum connections used wherever possible.

**7) Correct connection** – It may seem obvious but double check all coax, HDMI, power and IR cables are connected to the correct ports.

**Note:** Even a fraction off can be the difference between a perfect picture and a blank screen. Double check all connections are firmly made in the correct ports.

**8) Electrical interference** – SDI transmission is susceptible to interference from mains cable and electrical switching equipment (relays and lighting dimmers). The location of cables and devices should be considered prior to installation - could any form of interference be generated? If so, attempt to remove the source of

electrical interference or move the cable run to decrease the effects of the interference.

**9) Is a picture achieved when connecting the source directly to the display?** If not then the problem could lie with the input or output device rather than the means of distribution i.e. the cable, receiver or matrix itself.

**10) HDMI lead condition and quality** – HDMI cables and connectors are delicate and can be damaged much easier than component or coax cable. Furthermore, lead quality varies dramatically, particularly in lower price brackets. Swap HDMI leads and check operation – damage to or quality of your leads could be the problem. If in doubt, swap them over. Always take care inserting and extracting your HDMI from extender ports so as not to damage the connectors or ports.

**11) Picture speckles/HD 'noise'** – represents a poorly established signal that may be caused by poor quality coax or excessive HDMI cable lengths.

**12) HD Noise (NO image)** – may be an HDCP issue between the source and display but poor cabling can also cause this due to poor communication.

**13) Blu-ray: 3D** – is the equipment used 3D enabled/compatible? Is a 3D disc being played in a 3D enabled Blu-ray player or through a compatible AV receiver?

**14) Colour distortion** – a pink or green screen indicates an incompatibility between colour spacing formats – the commonly used RGB or YUV used by older displays. Some sources allow switching between RGB and YUV which may solve any colour problems. If not, try changing the HDMI cable between the source and the extender set to rule out defective cabling.

## No Sound or Poor Quality Audio

Audio is transmitted within the video signal – there is no separate audio track – so generally a problem with sound will be accompanied by a problem with picture. However, if technical issues with audio are experienced, the cause is typically communication between sources, displays and/or AV receiver settings.

**1) Have specific speaker sets or zones been enabled?** Some AV receivers allow individual speaker selections assigned to specific zones in the set up so check the speakers used are fully connected to the amplifier and correctly assigned within the system set up. It may be an EDID issue in that the source reads the audio

EDID from the display and only requests two channel audio and EDID copy from the AVR may be required or use an embedded EDID in the SDI extenders.

**Note:** If problems are experienced when an AV receiver is used, the cause is usually the settings of the AVR itself. Refer to the AVR manufacturer's guidelines on the correct settings to use for your requirements.

**2) Consistency of audio output between devices** – Is there any discrepancy between the audio output of the source, the audio or zonal settings of the AV receiver and the speaker configuration used needed for successful audio replication? If outputting 7.1, make sure all devices connected are also outputting 7.1

**Note:** Occasionally with some sources, the device settings allow the specification of audio output through a TV or an HDMI port. If using an AV receiver, check the HDMI output option is selected.

**3) Do all the local sources work through the AV receiver?**

Check the operation of each source individually.

## Bandwidth

**1)** If using a graphics-based source (such as a PC/Mac/media server), make sure the source resolution is set to a maximum of 1080p, 50Hz. Higher resolutions available for graphics-based systems require higher bandwidth that may affect transmission of signals as well as incompatibility with devices.

## IR

**1) Check emitters at the IR TX transmitter end and receivers at the IR RX receiver end** – are they connected to the correct ports on the matrix and display receiver.

**2) Is the emitter correctly positioned on the source?**

Fix the emitter directly over the infrared sensor of the source and attach using the adhesive backing.

Note: Locate the infrared source sensor by using a flashlight to find the sensor within the fascia of the source display. If necessary, secure the emitter over the sensor with a small amount of contact adhesive.

**3) Is the remote handset powered and sending a signal?**

**Note:** IR is invisible to the naked eye, so use a digital camera/ phone camera to check the remote signal – point the camera at the remote control when pressing a button. The remote transmitter can be seen flashing to indicate a

signal being sent. Replace batteries if flashing is not seen on the digital camera screen.

**4) IR dropout issues** can be due to exterior influences emitting infrared radiation that can interrupt IR signals. Ensure emitters and receivers are away from the following causes of IR interference.

- Direct sunlight, Fluorescent lighting (on cold start up)
- Halogen lighting
- Plasma screens

**5) Coax Termination Issues** – ensure cables and coax terminations are correct and in good condition at both transmitter and receiver ends to see if control is established. If so, a possible re-termination of the cable could remedy the problem.

**6) Are WyreStorm emitters and receivers being used?** The use of third party products/magic eyes may not be compatible. Always use WyreStorm components included with your purchase or check compatibility of third party control systems with your WyreStorm dealer.

**7)** If problems persist, swap out the IR emitters and receivers to rule out faults with the units themselves. Use emitters you know are fully operational to test working condition.

## 15. FAQs

### How far can the signal travel?

Under perfect transmission conditions WyreStorm SDI extender set will operate at 50m (@1080p).

Perfect conditions denotes no electrical interference, straight cable runs with no bends or kinks and no patch panels or wall outlets. If some of the above are factors in your installation then signal strength and bandwidth can be compromised.

Should a cable run approach the upper limit of the receiver capabilities, the signal can be boosted by connecting an additional RX-SDI-50 as an in-line repeater up to 7 times.

### What about 3D?

All WyreStorm products will pass-through a 3D Blu-ray signal.

### How do I control the sources?

All of our HDMI distribution products support IR pass-through from point-to-point extender sets to AMP and

HDBaseT matrices. Our PP and HDBaseT matrix range (Cat5e/Cat6) has IR pass-through from each of the outputs and has discrete IR outputs at the switch end, meaning you can have multiple identical sources yet the IR would be routed only to the applicable source.

**Do I need power at the TV end?**

Yes. This product requires its own 5v local power at display zones to operate.

WyreStorm PoH enabled devices require no power supply at the TV end by drawing power from a PoH matrix or PoH transmitter. See [www.wyrestorm.com](http://www.wyrestorm.com) for details on our PoH range.

**Are WyreStorm products compatible with HDMI 1.4?**

HDMI 1.4 refers to a list of ‘features’ that a device is capable of supporting, including Ethernet channel, return audio channel, 3D etc. Due to the continuously evolving nature of the technology, HDMI Licensing LLC have now decided to simplify terminology by testing and referring to cable in terms of STANDARD or HIGH-SPEED rather than in generations 1.3, 1.4 etc.

- STANDARD (or “category 1”) HDMI cables perform at speeds of 75Mhz or up to 6.75Gbps, which is the equivalent to a 720p/1080i signal – These HDMI cables are NOT recommended.
- All WyreStorm equipment support HIGH-SPEED (or “category 2”) HDMI cables that have been tested to perform at speeds of 340Mhz or up to 10.2Gbps, which is the highest bandwidth currently utilised over an HDMI cable and can successfully handle 1080p signals including those at increased colour depths and/or increased refresh rates from the Source. High-Speed cables are also able to accommodate higher resolution displays, such as WQXGA cinema monitors (resolution of 2560 x 1600).

**What about screens with different resolution capabilities?**

When sending a signal point to point a TV will communicate its capabilities to the source, with the source subsequently outputting a suitable signal compatible with the display (i.e. 1080p Stereo audio). If you were to use this extender set with three 1080p screens and one 1080i screen, the resultant image would be 1080i across all screens. The receivers do not scale per output but instead negotiate with the source a signal that all screens are capable of supporting.

**How does the Transmission device handle HDCP?**

HDCP (High Definition Copyright Protection) is a feature built in to HDMI devices to prevent theft of or illegal distribution of HD content. Unlike competing products,

WyreStorm equipment are legal and comply with HDCP regulations.

They do this by assigning a “key” to any display connected to the device. HDCP “keys” are assigned to a display when connected to a HDMI device normally. This doesn’t change when connecting to an extender, receiver or matrix switch; rather keys are duplicated or more are assigned.

**I can get 1080i but not 1080p at a TV location**

Firstly ensure that both the source is capable of outputting 1080p and that the TV is Full HD 1080p screen. If this is the case then the extender set may require an EDID setting using the DIP switches. This useful feature provides a successful “send and receive” to ensure swift and stable EDID negotiation between the source and display. See Troubleshooting section for more tips on problem solving.

**I cannot get a signal from my A/V receiver along a Cat5e extender set**

Check to ensure that the A/V Receiver isn’t adding CEC (HDMI Control Protocol) to the outgoing signal, this can sometimes have an effect on the HDMI signal.

---

## 16. Maintenance

---

Clean this unit with a soft, dry cloth only. Never use alcohol, paint thinner or other harsh chemicals.

---

## 17. Product Service

---

**1. Damage requiring service:** This unit should be serviced by a qualified service personnel if:

- The DC power supply or AC adaptor has been damaged.
- Objects or liquid have gotten into the unit.
- The unit has been exposed to rain.
- The unit does not operate normally or exhibits a marked change in performance.
- The unit has been dropped or the cabinet damaged.

**2. Servicing Personnel:** Do not attempt to service the unit beyond that described in these operating instructions. Refer all other servicing to authorised servicing personnel.

**3. Replacement Parts:** When parts need replacing, ensure parts approved by the manufacturer are used – either those specified by the manufacturer or parts

possessing the same characteristics as the original parts. Be aware – unauthorised substitutes may result in fire, electric shock, or other hazards and will invalidate your warranty.

**4. Safety Check:** After repairs or service, ask the service personnel to perform safety checks to confirm the unit is in proper working condition. When shipping the unit, carefully pack and send it prepaid, with adequate insurance and preferably in the original packaging. Please include a document or letter detailing the reason for return and include a daytime telephone number and/or email address where you can be contacted.

## 18. Mail-in-service

If repair is required during the limited warranty period, the purchaser will be required to provide a sales receipt or other proof of purchase, indicating date and location of purchase as well as the price paid for the product. The customer will be charged for the repair of any unit received unless such information is provided.

## 19i. Warranty

Should you feel your product does not function adequately due to defects in materials or workmanship, WyreStorm (referred to as “the warrantor”) will, for the length of the period indicated below (starting from the original date of purchase) either:

- a) Repair the product with new or refurbished parts.
- or
- b) Replace it with a new or refurbished product.

### Limited warranty period:

All WyreStorm products are covered by a 3 year PARTS and LABOUR warranty. During this period there will be no charge for unit repair, replacement of unit components or replacement of product if necessary.

The decision to repair or replace will be made by the warrantor. The purchaser must mail-in the product during the warranty period. This limited warranty only covers the product purchased as new and is extended to the original purchaser only. It is non-transferable to subsequent owners, even during the warranty period. A purchase receipt or other proof of original purchase date is required for the limited warranty service.

## 19ii. Warranty Limits & Exclusions

**1. This Limited Warranty ONLY COVERS failures due to defects in materials or workmanship and DOES NOT COVER normal wear and tear or cosmetic damage.**

The limited warranty also DOES NOT COVER damage that occurs in shipment or failures caused by products not supplied by the warrantor, failures resulting from accident, misuse, abuse, neglect, mishandling, misapplication, alteration, incorrect installation, set-up adjustment, implementation of/to consumer controls, improper maintenance, power line surge, lightening damage, modification, service by anyone other than a manufacturer-approved service centre or factory-authorized personnel, or damage attributable to acts of God.

**2. There are no express warranties except as listed under “limited warranty coverage.” The warrantor is not liable for incidental or consequential damage resulting from the use of this product or arising out of any breach of this warranty.**

For example: damages for lost time, the cost of having a person/persons remove or re-install previously installed equipment, travel to and from service location, loss of or damage to media, images, data or other recorded/stored content. The items listed here are not exclusive, but are for illustration only.

Parts and service not covered by this limited warranty are not the responsibility of the warrantor and should be considered the responsibility of the individual.

---

## 20. Installation Notes

---





[www.wyrestorm.com](http://www.wyrestorm.com)

■ **WyreStorm Offices**

US Office: 6991 Appling Farms Parkway, Suite 104, Memphis, TN 38133

Tel: + 901 384 3575 Fax: + 901 384 3574

Unit 22, Ergo Business Park, Swindon, Wiltshire, SN3 3JW UK

Tel: +44 (0) 1793 230 343 Fax: +44 (0) 1793 230 583

■ **WyreStorm Technical Support**

US: +86 6677 0053

UK:- +44 (0) 1793 238 338

Email: [support@wyrestorm.com](mailto:support@wyrestorm.com)

**WyreStorm Technologies reserve the right to change physical appearance or technical specification of this product at any time.**

**Visit [www.wyrestorm.com](http://www.wyrestorm.com) for the latest information on products..**