



RHINO-RACK

Rhino 2500 Series - Two Bar Heavy Duty System.

Important:

Please refer to your fitting instruction to ensure that the roof racks are installed in the correct locations. Check the contents of kit before commencing fitment and report any discrepancies. Place these instructions in the vehicle's glove box after installation is complete.

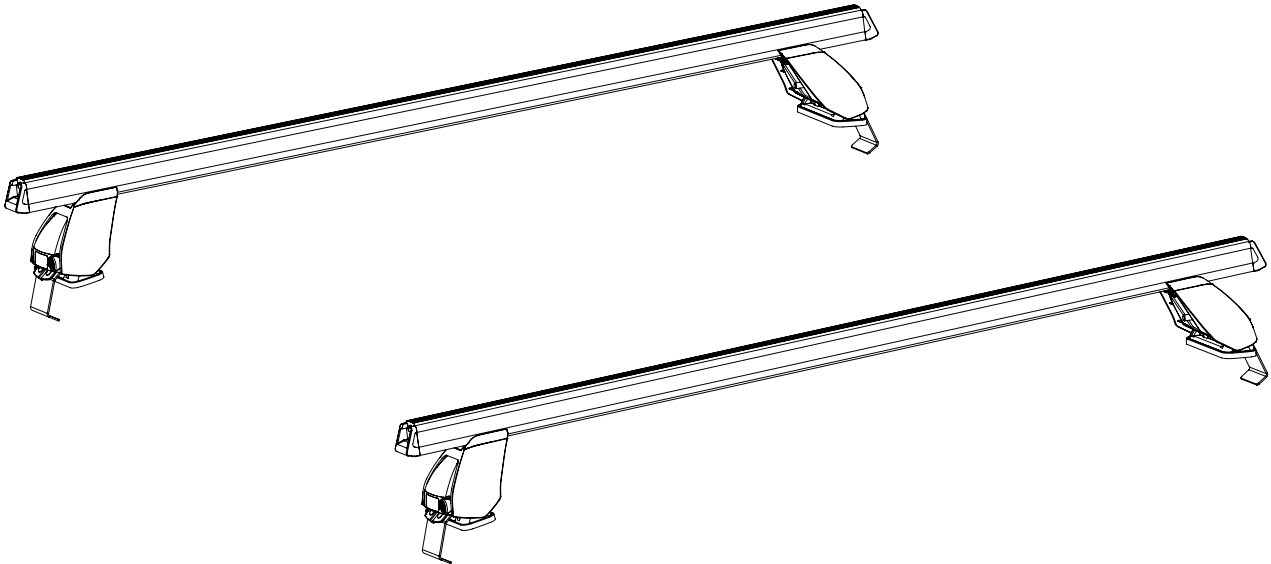

Maximum carrying capacity: 75kg (165lbs) evenly distributed over crossbars. Please refer to your vehicle manufacturers handbook and DK Specification sheet for maximum roof loading. Always use the lower of the two figures.

Recommendations:

It is essential that all bolt connections be checked after driving a short distance when you first install your crossbars. Bolt connections should be checked again at regular intervals (probably once a week is enough, depending on road conditions, usage, loads and distances travelled). You should also check the crossbars each time they are refitted. Make sure to fasten your load securely. Please ensure that all loads are evenly distributed and that the centre of gravity is kept as low as possible.

Use only non-stretch fastening ropes or straps.

Load Ratings

When these roof racks are to be used on a vehicle that is driven off sealed roads, the manufacturer maximum roof load rating (to be found in the vehicles User Manual) should be **halved**. For example, if the vehicles maximum roof load rating is 70kgs (subtract 5kg - weight of crossbar and legs), these racks, when fitted to this vehicle should have no more than 35kgs loaded on them

Caution:

The handling characteristics of the vehicle changes when you transport a load on the roof. For safety reasons we recommend you exercise extreme care when transporting wind-resistant loads. Special consideration must be taken into account when cornering and braking. **Please remove crossbars when putting vehicle through an automatic car wash.**

Note for Dealers and Fitters:

It is your responsibility to ensure instructions are given to the end user or client.



Rhino 2500 Series - Two Bar Heavy Duty System

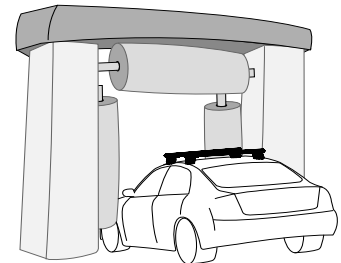
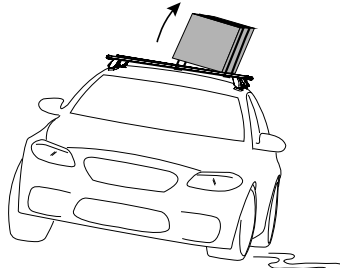
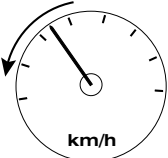
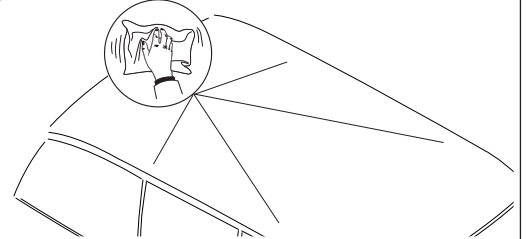
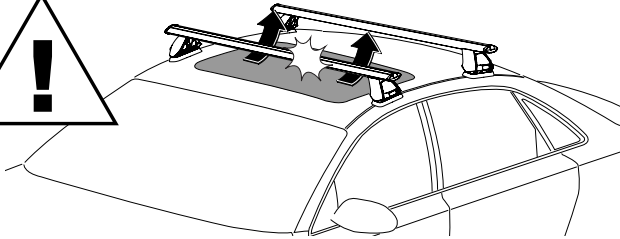
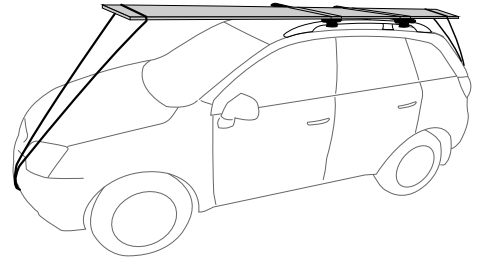
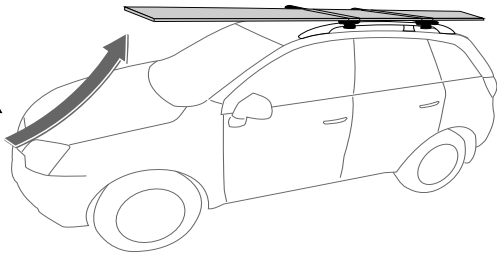

2 x Crossbars = 5kg

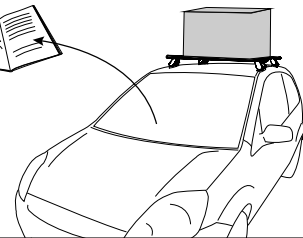
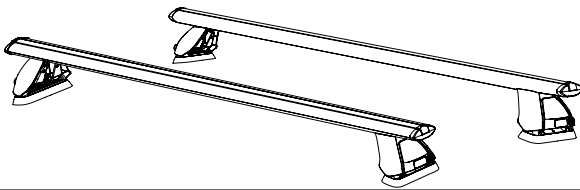

? kg

When these roof racks are to be used on a vehicle that is driven off sealed roads, the manufacturer maximum roof load rating (to be found in the vehicles User Manual) should be **halved**. Do not forget to subtract 5kg from your maximum carrying capacity due to the weight of the crossbars and legs.

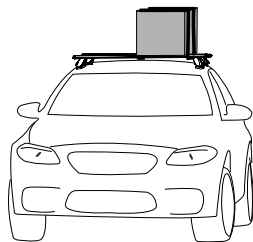

70kg load rating (Urban road) = **35 kg load rating** (Off road - 70kg / 2)

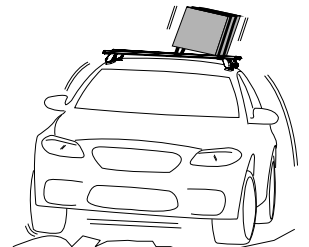

WARNING! Important Load Carrying Instructions

With utility vehicles, the cabin and the canopy move independently. Roof racks and vehicle can be damaged if the item transported is rigidly fixed at points on both the cabin and canopy. Instead, rigidly fix to either the cabin roof racks or the canopy roof racks.

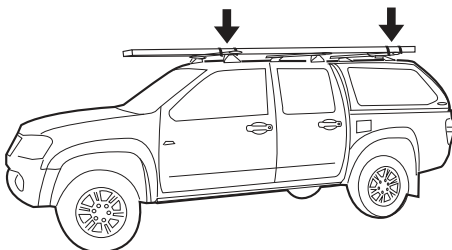

X NO

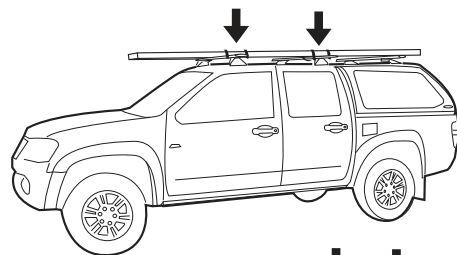

✓ YES

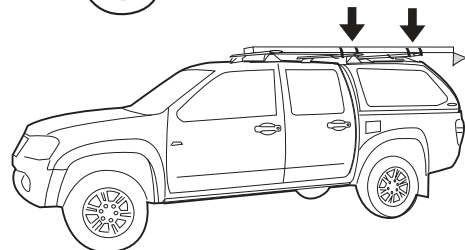

✓ YES



Rhino 2500 Series - Two Bar Heavy Duty System

Parts List Carrying Capacity: Refer to DK specification sheet for maximum carrying capacity of your particular vehicle.

Item	Component Name	Qty	Part No.
1	Rubber Buffer Strip	2	
2	Heavy Duty Cross Bar	2	
3	M8 Pivot Nut	4	N047
4	M8 x 50mm Security Bolt	4	B154
5	End Cap	4	M002
6	Heavy Duty Cross Bar Adaptor	4	M315
7	Leg	4	M310
8	Leg Cover Plate	4	M324
9	M6 Channel Nut	4	N002
10	M6 Flat Washer	4	W031
11	M6 Spring Washer	4	W004
12	M6 x 25mm Security Screw	4	B137
13	Front Cover	4	M312
14	Front Cover Key	2	M314
15	Foot Plate	4	M311
16	Security Allen Key	1	SecKey-L
17	Leg Location Decals	4	S365
18	Arrow Positioning Decals	4	S364
19	Fitting Instruction	1	RR244

Tools Required:

- Security Allen key, provided in kit.
- Tape measure.
- Rubber mallet.

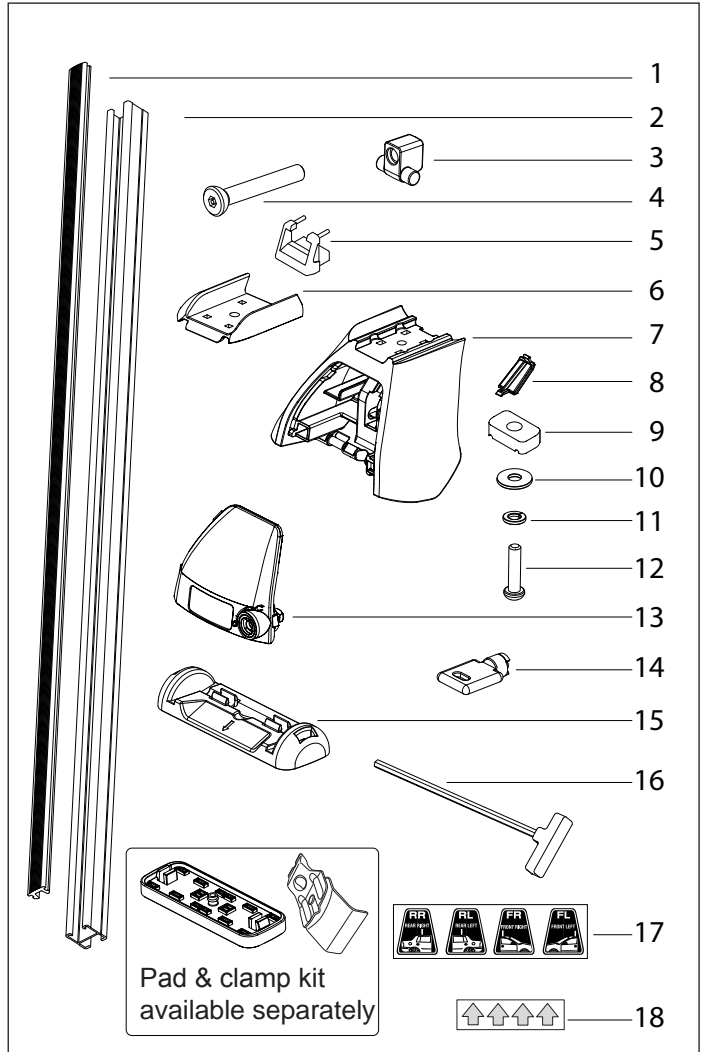

NOTE : Refer to the DK kit specification sheet for correct placement (Front & Rear, Left & Right) of the foot plate, rubber pad and metal strap. Also refer for sizes to cut the bar measurement strips.

1 Attach hardware:

- Attach the heavy duty cross bar adaptor onto top of the leg. Push to snap in place.
- Locate the M6 x 25mm security screw, spring washer and flat washer through top of the leg and fasten to the M6 channel nut. Do not tighten at this stage.
- Make sure the M8 pivot is correctly located as shown below.

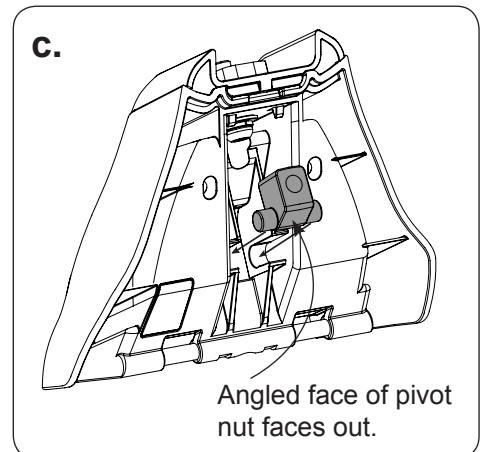
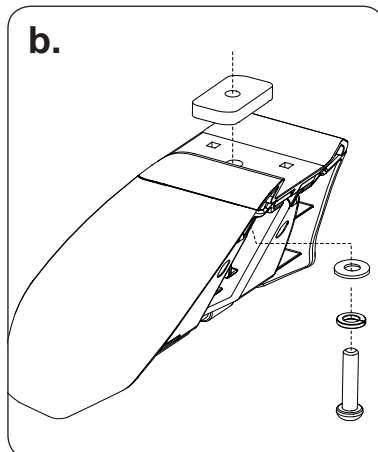
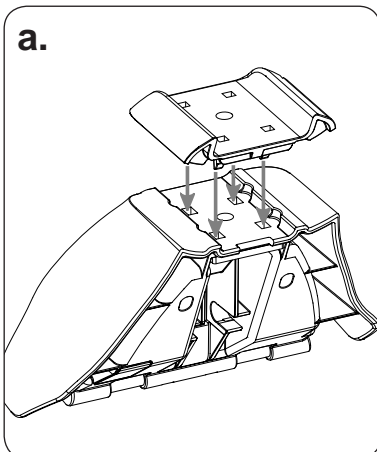



Rhino 2500 Series - Two Bar Heavy Duty System

2 Attach pad to foot plate.

Clip the rubber pad onto the foot plate. Pad centre tube and end tabs must fully locate into the foot plate.
Note: Certain rubber pad sets have a DK supplement sheet to show correct orientation.

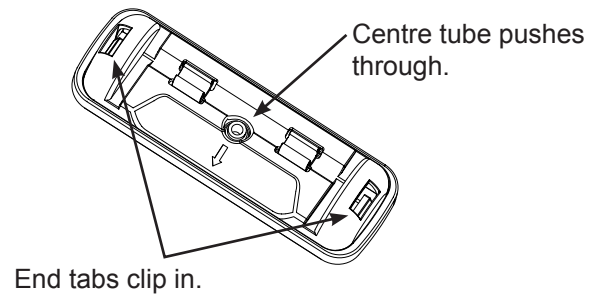
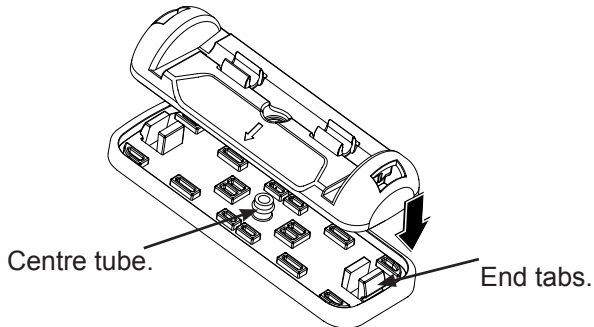

3

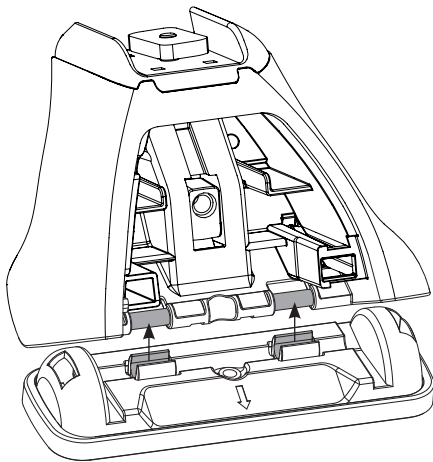

Attach foot plate to leg.

Clip the foot plate onto base of the leg with the arrow facing **In** or **Out** according to your vehicle listed in the DK specification sheet. Diagram at left shows arrow facing **Out**.

DK spec sheet.

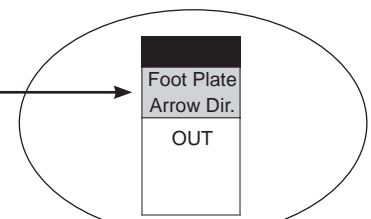

example only.

4

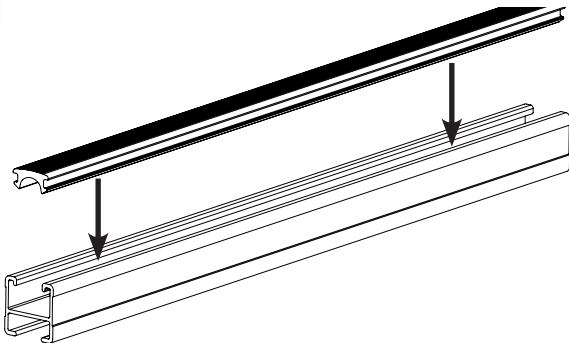

Crossbar rubber:

Push the cross bar rubber buffer strip into top of the bar.

5 Attach cross bar:

- Locate leg with channel nut into cross bar.
- Turn to locate the channel nut to sit across the bar.

a.

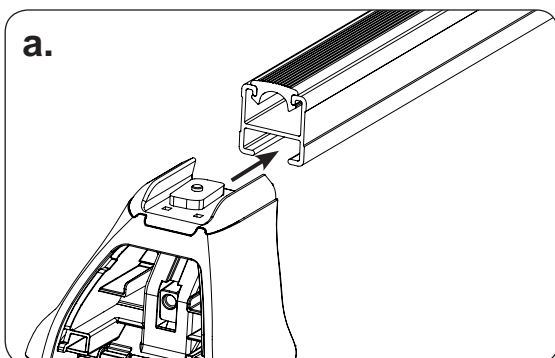

b.

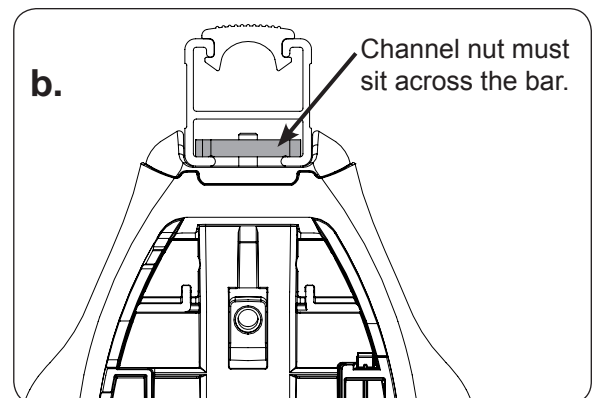



Rhino 2500 Series - Two Bar Heavy Duty System

6 Measurement between legs:

Accurately measure between the legs to set the correct distance. Refer to DK specification sheet for vehicle specific distance. Also set equal cross bar over hang. Tighten M6 security screw to **4-5 Nm (35-44 lbf.in)**

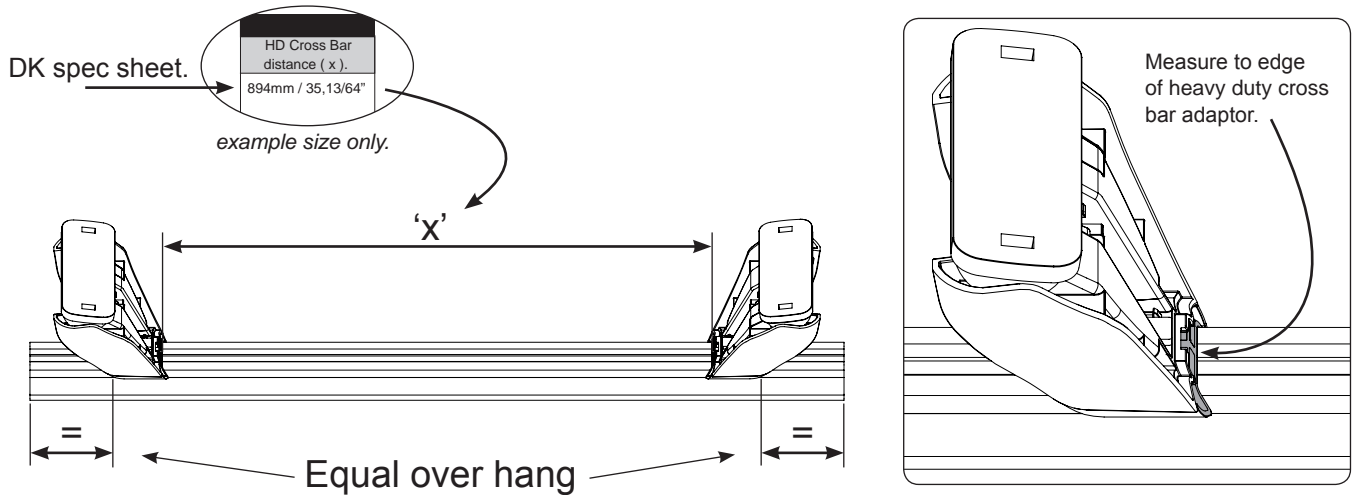

7

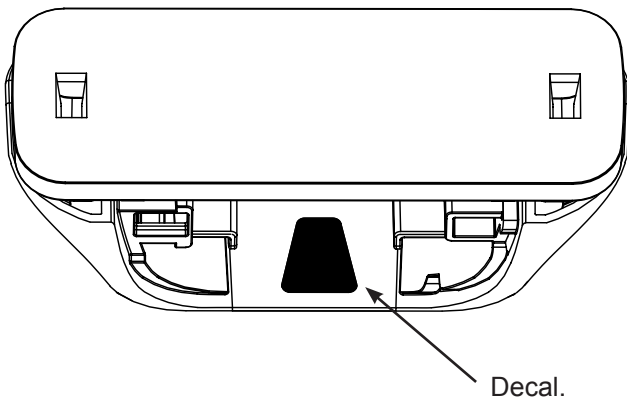

Leg location decals:

Stick the leg position labels inside the leg. The labels are used to easily identify front and rear cross bars if they are removed from vehicle. Refer layout below.

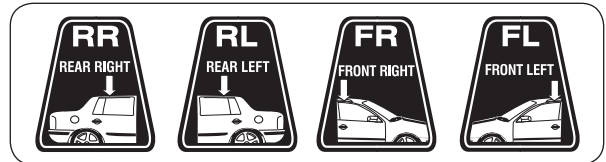

8 Position roof racks:

Place racks onto the vehicle roof. Refer to DK specification sheet for correct positioning of your roof racks.

A. Measure forward from a centre line of where the front and rear doors meet/close.

B. Measure back to set distance between cross bars.

A and B measurements are to be in line with arrow in centre of foot plate.

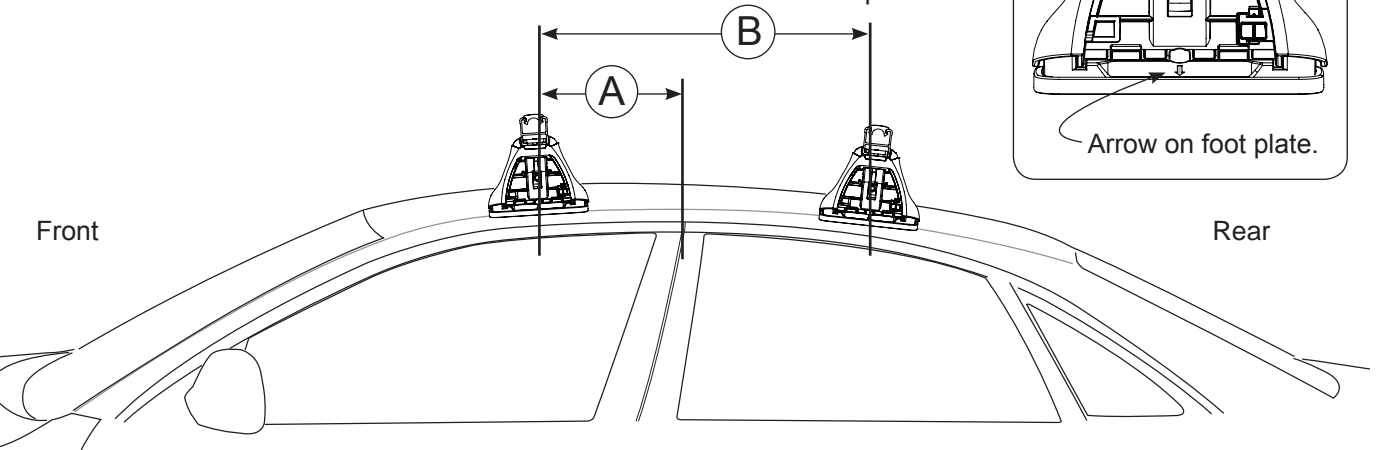



Rhino 2500 Series - Two Bar Heavy Duty System

9 Positioning decals:

Stick the white arrow decals in line with foot plate arrows onto the body work inside the door jamb. This marks reference points for future use when racks are removed and then replaced.

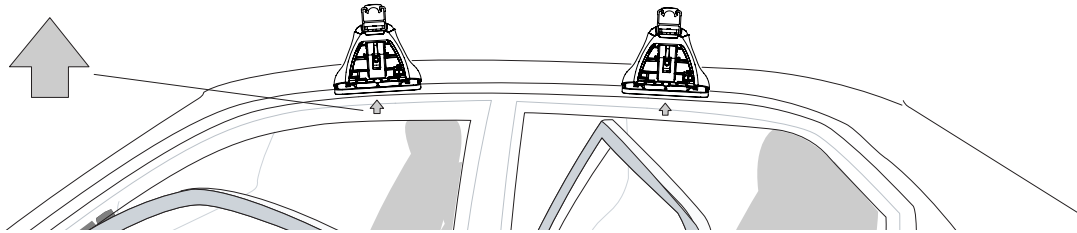

10 Attach clamps:

- Hook the lower part of the metal clamp in at the top of the door jamb underneath any rubber seals that may be present. Fasten the M8 bolt to the pivot nut in the leg.
- Bolts must be tensioned evenly on each side of the vehicle to avoid pulling the rack to one side.** Do not tighten one side at a time. Tighten M8 bolt to 12-14 Nm (106-123 lbf.in). Refer to DK instruction for correct clamp and pad combination for front and rear of vehicle.
- Knock end caps into end of cross bars. A rubber mallet may be used.

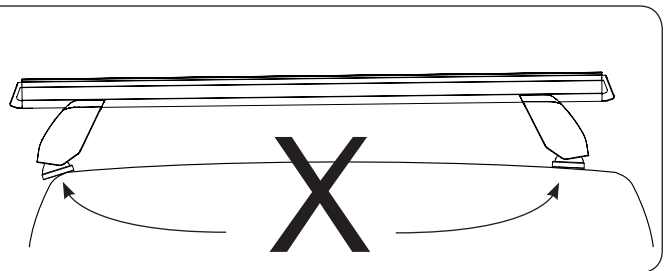
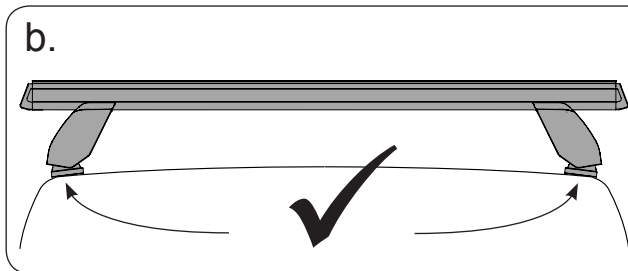
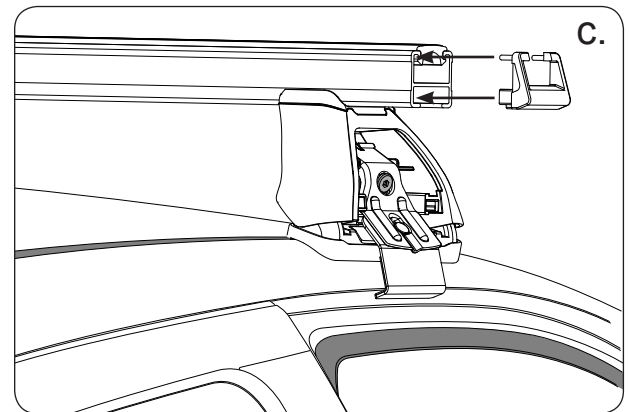
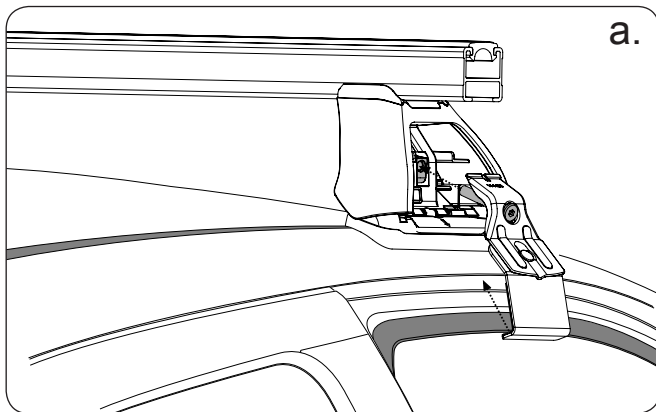

11

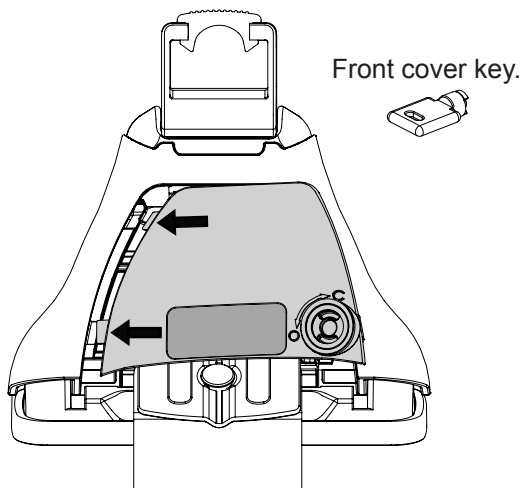

Attach front cover.

Insert the two lugs on left side of front cover into the leg. Use key provided to turn lock barrel to the open position (O). Engage locking tab into leg. Turn to close (C).

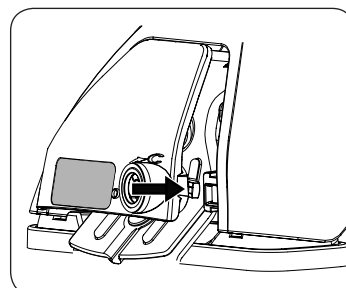

Open.

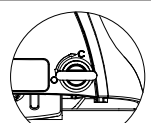

Closed.

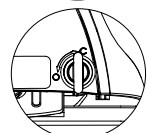



Rhino Rack 2500 Series - DK195

FRONT							
VEHICLE	Date	Crossbar	Pad / Clamp FRONT RIGHT	Pad / Clamp FRONT LEFT	Foot plate arrow direction	Bar measurement strip. Length per side.	HD Crossbar distance (x).
Toyota Prius (ZVW30R) 5dr hatch	2009-	1180mm	M282 / SUB0261	M281 / SUB0261	OUT	124mm	926mm / 36,29/64"
Toyota Prius v (ZVW40) 5dr wagon	2012-	1260mm	M282 / SUB0261	M281 / SUB0261	OUT	28mm	930mm / 36,39/64"
Toyota Prius+ (ZVW40) 5dr wagon	2012-	1260mm	M282 / SUB0261	M281 / SUB0261	OUT	28mm	930mm / 36,39/64"
REAR							
VEHICLE	Date	Crossbar	Pad / Clamp REAR RIGHT	Pad / Clamp REAR LEFT	Foot plate arrow direction	Bar measurement strip. Length per side.	HD Crossbar distance (x).
Toyota Prius (ZVW30R) 5dr hatch	2009-	1180mm	M284 / SUB0261	M283 / SUB0261	OUT	106mm	890mm / 35,3/64"
Toyota Prius v (ZVW40) 5dr wagon	2012-	1260mm	M284 / SUB0261	M283 / SUB0261	OUT	11mm	896mm / 35,9/32"
Toyota Prius+ (ZVW40) 5dr wagon	2012-	1260mm	M284 / SUB0261	M283 / SUB0261	OUT	11mm	896mm / 35,9/32"



Rhino Rack 2500 Series - DK195

Measurement A: CENTRE of door jamb to CENTRE arrow of leg foot plate.

Measurement B: CENTRE of Front leg foot plate arrow to CENTRE of Rear leg foot plate arrow.

Carrying capacity: Roof rack is rated to 75kg. Please refer to manufacturers handbook for your vehicles maximum roof load capacity. Always use the lower of the two figures.

Pad M281, FRONT Left. Arrow forward.

Pad M283, REAR Left. Arrow forward.

Pad M282, FRONT Right. Arrow forward.

Pad M284, REAR Right. Arrow forward.

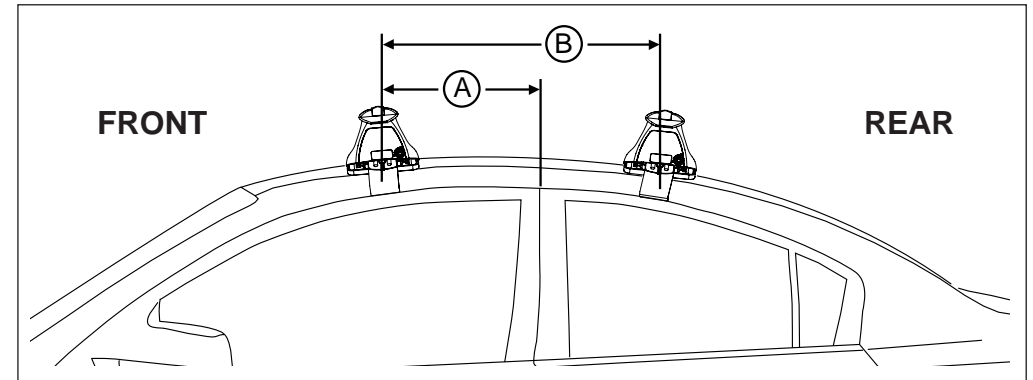
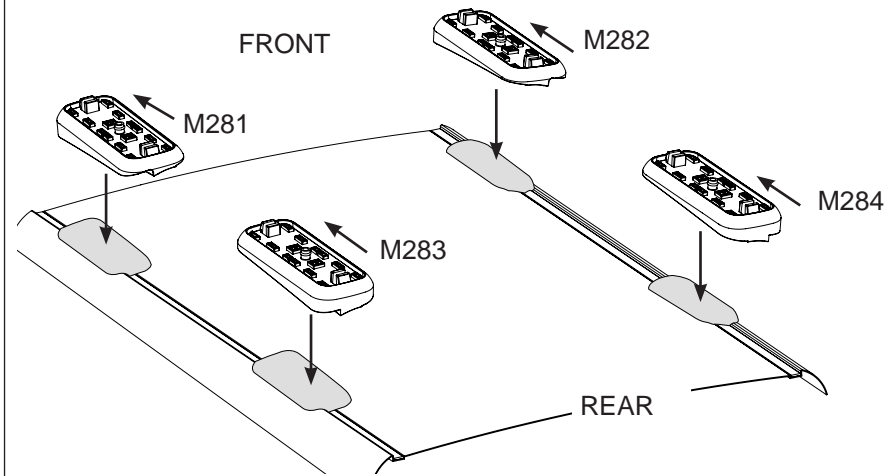

Pad positioning

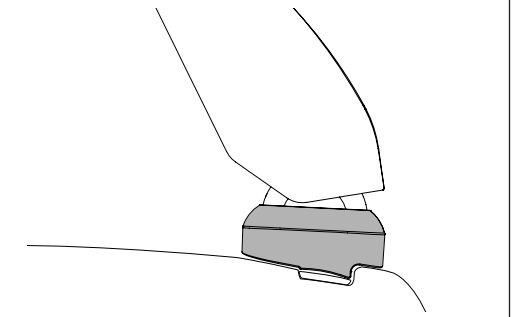

VEHICLE	Date	Measurement A	Measurement B	Load rating (includes racks 5kg / 11lbs)
Toyota Prius (ZVW30R) 5dr hatch	07/09-	270mm / 10,5/8"	700mm / 27,9/16"	50kg / 110lbs
Toyota Prius v (ZVW40) 5dr wagon	2012-	50mm / 1,31/32"	700mm / 27,9/16"	60kg / 132lbs
Toyota Prius+ (ZVW40) 5dr wagon	2012-	50mm / 1,31/32"	700mm / 27,9/16"	60kg / 132lbs