

# MTBK-R109 MADI Board



## User Manual

Version: DOC-1.1 (May 2007)© 2007 Merging Technologies Inc.

## 1 IMPORTANT NOTICE:

Please read the following information very carefully before attempting any installation. Failure to comply with the precise instructions may result in damage to your Merging hardware. Please read this entire section of the manual carefully before installation.

### 1.1 STATIC DANGER NOTICE:

Please note that the Mykerinos board contains delicate electronic components that can be damaged or even destroyed when exposed to static electricity. Take all necessary precautions not to discharge static electricity when touching any of the Mykerinos components.

### 1.2 INFORMATION FOR THE USER:

Mykerinos and its daughter card comply with the following specifications:

#### EMC Emissions

EN 55022 : 1994 /A1 : 1995 /A2 : 1997 Class A ITE emissions requirements (EU)  
FCC 47 CFR Part 15 Class A emissions requirements (USA)

#### EMC Immunity

EN 50082-1: 1992 EMC residential, commercial and light industrial generic immunity standard.

#### FCC Notice

This product has been tested and found to comply with the limits for a Class A digital device, pursuant to Part 15 of the FCC rules. Operation is subject to the following two conditions: (1) This device may not cause harmful interference, and (2) This device must accept any interference received, including interference that may cause undesired operation. These limits are designed for providing reasonable protection against harmful interference in a residential installation. This equipment generates, uses and can radiate radio frequency energy and, if not installed and used in accordance with the instructions contained in this manual, may cause harmful interference to radio and television communications. However, there is no guarantee that interference will not occur in a particular installation.

NOTE: Connecting this device to peripheral devices that do not comply with CLASS A requirements or using an unshielded peripheral data cable could also result in harmful interference to radio or television reception. The user is cautioned that any changes or modifications not expressly approved by the party responsible for compliance could void the user's authority to operate this equipment. To ensure that the use of this product does not contribute to interference, it is necessary to use shielded I/O cables.

#### CE Notice

Such a  marking is indicative that this system's devices meet the following applicable technical standards:

EN 55022 – “Information Technology Equipment - Radio disturbance characteristics Limits and methods of measurement”

EN 50082-1: 1992 – “Electromagnetic compatibility – Generic immunity standard Part 1: Residential, commercial, and light industry”

This product is classified for use in a typical Class A commercial environment, and is not designed or intended for use in other EMC environments. The user of this product is obliged for proper use and installation of the product and for taking all steps necessary to remove sources of interference to telecommunications or other devices.

## 2 MTBK-R109 Warranty Information

This product is warranted to be free of defects in materials and workmanship for a period of one year from the date of purchase. Merging Technologies, Inc. extends this Limited Warranty to the original purchaser.

In the event of a defect or failure to conform to this Limited warranty, Merging Technologies, Inc. will repair or replace the product without charge within sixty (60) days. In order to make a claim under this limited warranty, the purchaser must notify Merging Technologies, Inc. or their representative in writing, of the product failure. In this limited warranty the customer must upon Merging Technologies, Inc. request, return the product to the place of purchase, or other local designation, for the necessary repairs to be performed. If the consumer is not satisfied with the repair, Merging Technologies, Inc. will have the option to either attempt a further repair, or refund the purchase price.

This warranty does not cover: (1) Products which have been subject to misuse, abuse, accident, physical damage, neglect, exposure to fire, water or excessive changes in the climate or temperature, or operation outside maximum rating. (2) Products on which warranty stickers or product serial numbers have been removed, altered or rendered illegible. (3) The cost of installations, removal or reinstallation. (4) Damages caused to any other products.

### 3 Table of Contents

<b>1</b>	<b>IMPORTANT NOTICE:</b> .....	<b>2</b>
1.1	STATIC DANGER NOTICE: .....	2
1.2	INFORMATION FOR THE USER: .....	2
<b>2</b>	<b>MTBK-R109 WARRANTY INFORMATION</b> .....	<b>3</b>
<b>3</b>	<b>TABLE OF CONTENTS</b> .....	<b>4</b>
<b>4</b>	<b>WHAT IS MADi (MULTI CHANNEL AUDIO DIGITAL INTERFACE)?</b> .....	<b>5</b>
<b>5</b>	<b>MAIN FEATURES</b> .....	<b>7</b>
5.1	INPUT/OUTPUT EXPANSION.....	7
5.2	CASCADE.....	12
<b>6</b>	<b>HARDWARE</b> .....	<b>14</b>
6.1	MADI MODE .....	14
6.2	CASCADE MODE .....	14
6.3	WORD SYNC INPUT/OUTPUT .....	14
<b>9</b>	<b>HARDWARE SPECIFICATION</b> .....	<b>15</b>
<b>10</b>	<b>DIMENSIONS</b> .....	<b>16</b>
<b>11</b>	<b>CONDITIONS OF USE</b> .....	<b>17</b>
<b>12</b>	<b>SYSTEM EXAMPLE</b> .....	<b>18</b>
12.1	I/O EXPANSION . MUSIC RECORDING SYSTEM.....	18
12.2	CASCADE. MIX DOWN SYSTEM .....	18
12.3	CASCADE. MUSIC RECORDING SYSTEM.....	19
<b>13</b>	<b>CONTACTING MERGING</b> .....	<b>20</b>

## 4 What is MADI (Multi Channel Audio Digital Interface)?

The MADI format is capable of transmitting 56 digitally encoded audio signals (samples at standard sample rates 44.1 or 48kHz) on a standard 75ohm co-ax or fibre cable. Specifically, MADI can ‘transparently’ transmit 28 AES/EBU channel pairs, with 24-bit resolution and all of the associated channel status information.

The MADI format is fully specified in the AES 10 Information Document <http://www.aes.org/standards/reports> and is supported by many Pro Audio manufacturers.

MADI is uni-directional and provides a ‘point to point’ interface between a source and a destination. Time Division Modulation (TDM) is used to multiplex the 56 audio channels on to a single cable. It is specified to use both 75ohm co-ax (standard video cable) or fibre, providing a balance between operating distances and installation costs.

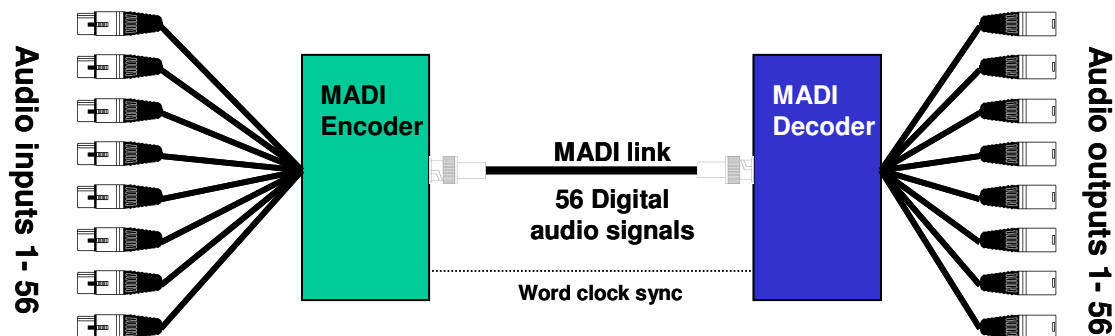

MADI can be used to transmit higher sampling rate audio signals (ie 96 kHz), there are two alternate methods specified for higher sample rate. In both methods the number of audio channels is reduced (therefore 26 mono, 96 kHz audio channels can be transmitted by MADI).

### Why is MADI important?

There are many factors driving the importance of MADI in modern production systems. These factors include: the overall growth in the use of digital audio equipment, the ever increasing demand for larger productions and the requirements of surround sound processing. MADI is an attractive technology as it provides the simplest method of transmitting ‘sample accurate’ audio channels over distances between a few metres and several kilometres.

### Sound quality

MADI has ‘low jitter’ and is a ‘sample accurate’ format, thus ensuring the maximum sound quality is retained in a digital audio production system.

### Low installation costs and rationalised system design

MADI provides a ‘smart’ and low method of transmitting audio channels, compared to the traditional method of using analogue ‘multi-cores’. The MADI user can benefit from cost savings and lower maintenance.

Some manufacturers provide MADI equipment with remote controlled microphone amplifiers and digital routing, often controlled by a PC application. These integrated systems often further rationalisation of audio routing system, for example instant re-call of patching.

### **Long transmission distances**

The fibre cable option for MADI allows for transmission distances of several kilometres. There are many applications where long distance audio transmission can be useful: outside broadcast venues, multi-room production facilities, live venues, etc.

### **MADI in modern surround sound production systems**

Surround sound productions demand large amounts of audio processing, transmission and storage, and MADI is a highly suitable technology for the modern surround sound studio. The increase in the amount of processing and signal management is far beyond the need to triple the number of output channels (from a two channel stereo master to the 6-channel 5.1 Master output). Studios often need to simultaneously produce 5.1, LCRS and stereo outputs, and classical film style product often specify multiple surround sound Stem outputs.

Sample accuracy is particularly important in matrixed surround sound production systems, where any 'bit slip' can cause serious audio problems with various surround encoders. In particular, MADI can be used to transmit one of the most demanding audio mastering formats specified for DVD-V, which is 5.1 surround sound, sampled at 96kHz.

MADI is being used to.....

- transmit digitised microphone signals for a 'stage box' to a theatre's mixing console.
- multi-channel link between a mixing console and multi-track recorder
- transmission format in large scale digital audio routing systems

The new MTBK-R109 MADI Board provides a MADI I/O interface for the DMX-R100. This board expands the I/O possibilities by 48 inputs and outputs using only 1 option slot enabling the other 3 slots of the DMX-R100 to be used for existing 8ch I/O cards. This new board also offers the possibility of CASCADE mode offering mixing with 48 faders and expanding I/O using two DMX-R100's.

## 5 MAIN FEATURES

### 5.1 Input/Output expansion

The number of digital inputs on the DMX-R100 can be significantly expanded by installing the new MTBK-R109 MADI (Multichannel Audio Digital Interface) Board. This board conforms to the industry standard AES 10 MADI I/O format and offers 48 input/outputs on a single board. When installed, a maximum of 72 optional inputs become available to the DMX-R100, 48 through the MADI board and 24 through the three remaining board slots when fitted with optional I/O board. Multitrack recorders such as the Sony PCM-3348HR, hard disk recorders, audio routers and microphone pre amps support the MADI standard and will connect to the DMX-R100 via the MTBK-R109 board.

#### Number of channels with 4 optional slots

Current

Max.  $8 \times 4 + 6$  standard  
AES/EBU = 38 ch



+48 ch

With MADI board (MTBK-R109)

Max.  $8 \times 3 + 6$  standard AES/EBU  
+ 48 = 78 ch

Slot No	I/O channels
Slot 1	8 ch
Slot 2	8 ch
Slot 3	8 ch
Slot 4	8 ch / 48 ch

MADI Board (MTBK-R109)



**Standard DMX-R100 audio interfacing without MADI card**  
**Total digital I/O 38 channels- 6 as standard, 32 on MTBK cards**

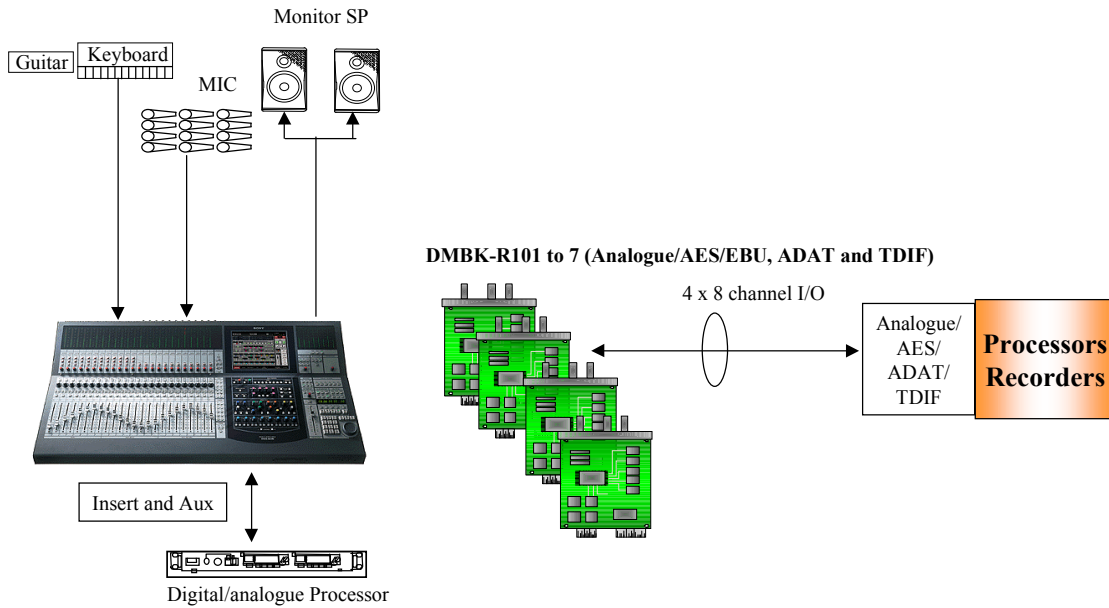

**DMX-R100 audio interfacing with the MTBK-R109 MADI card**  
**Total digital I/O 78 channels- 6 as standard, 24 on MTBK cards, 48 with MADI**

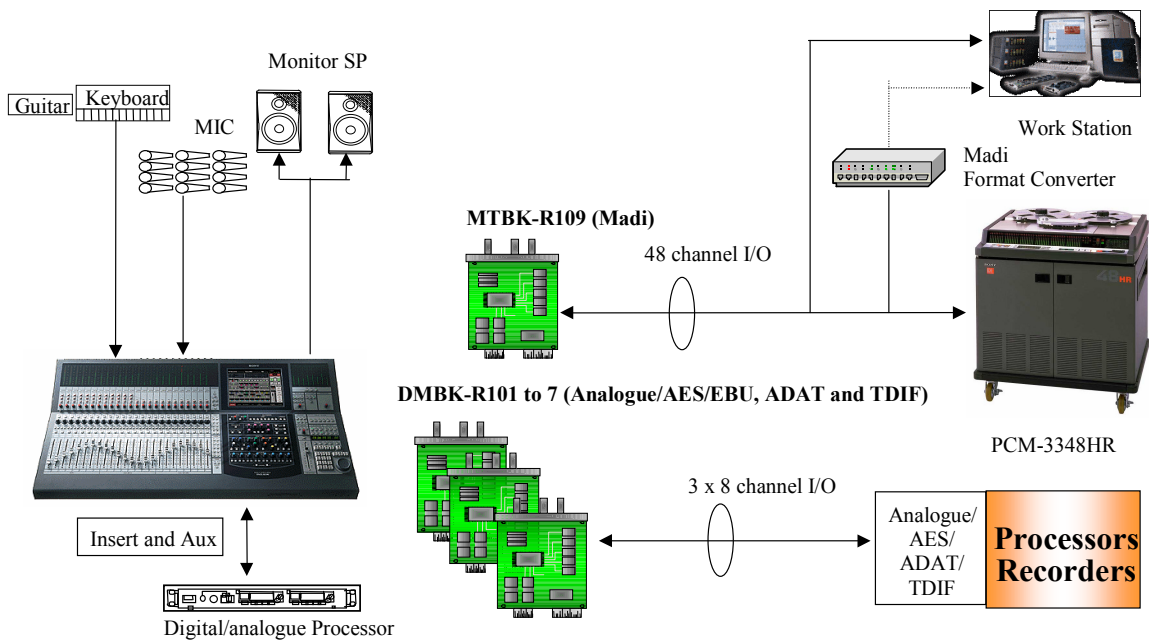



## The MADI card and 96Khz ?

The MTBK-R109 will operate at double sample rates (88.2/96 KHz) but the number of I/O channels is reduced by half to 24 inputs and 24 outputs. A DMX-R100 operating at 96 KHz fully configured with 3 x AES I/O and 1 x MADI card will allow 54 inputs and outputs

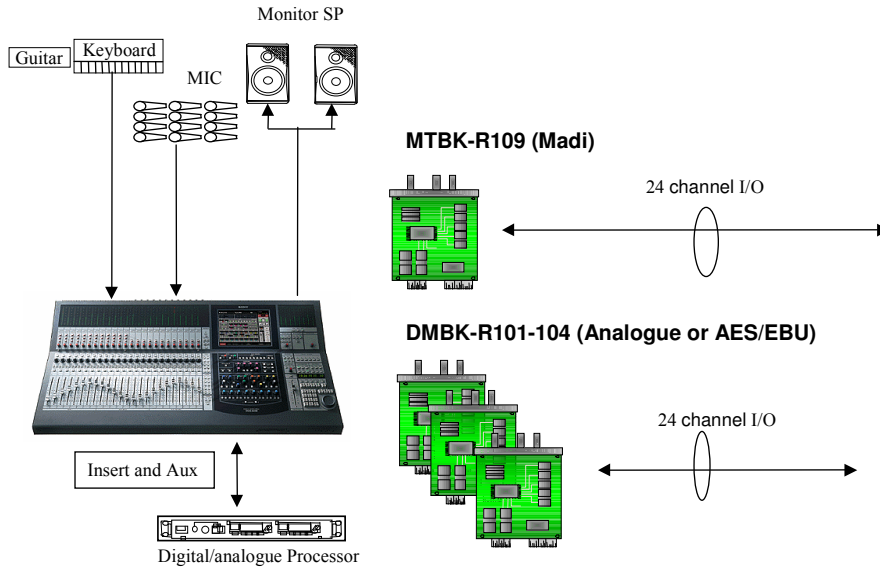

## Routing and Status GUI's

New GUI pages have been updated to select the INPUT and OUTPUT routing of the MTBK-R109. Any MADI input signals can be routed to any of the R100 inputs slots.

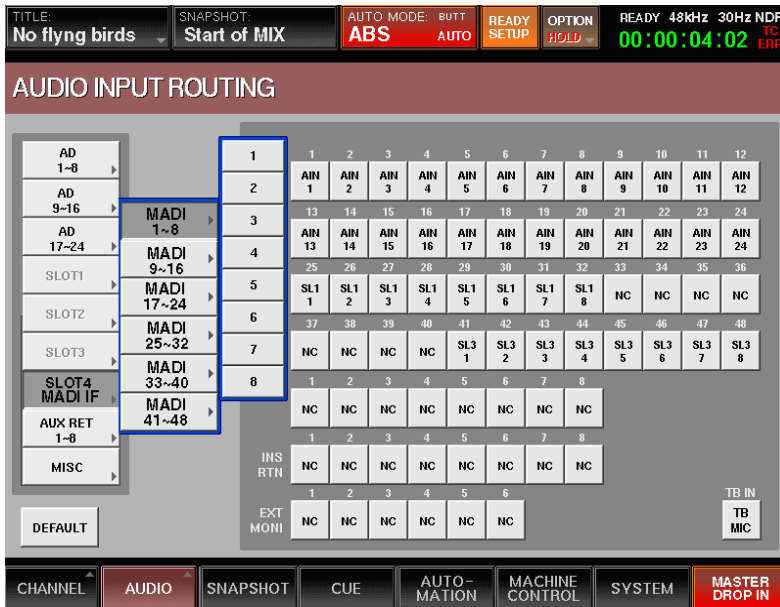

Any of the DMX output buses can be routed to any of the MADI output slots using the output routing GUI

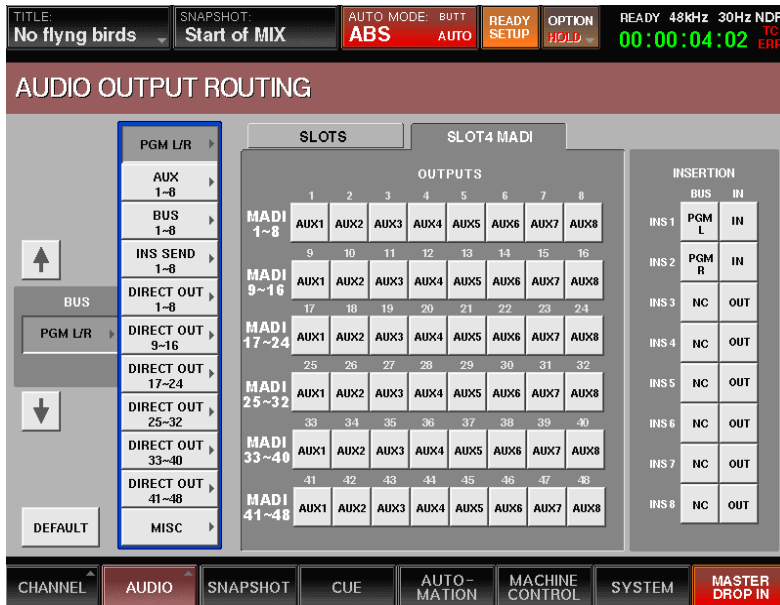

The I/O Status GUI has been updated to show the input status of the MTBK-R109 MADI card and to show the source and destination information on the MADI output channels.

TITLE: <b>No flying birds</b>		SNAPSHOT: <b>Start of MIX</b>		AUTO: <b>WH TH</b> BUTT <b>ABS</b> <b>NORMAL</b>	READY SETUP	OPTION	READY 48kHz 30Hz NDF <b>00:00:00:00</b>											
<b>I/O STATUS</b>																		
<b>SLOT 1:</b>				<b>SLOT 2:</b>														
	1	2	3	4	5	6	7	8		1	2	3	4	5	6	7	8	
IN	NA	NA	NA	NA	NA	NA	NA	NA	IN	NA	NA	NA	NA	NA	NA	NA	NA	
OUT	NA	NA	NA	NA	NA	NA	NA	NA	OUT	NA	NA	NA	NA	NA	NA	NA	NA	
<b>SLOT 3:</b>				<b>SLOT 4: DMBK-R109 MADI BOARD</b>														
	1	2	3	4	5	6	7	8		1	2	3	4	5	6	7	8	PAGE
IN	NA	NA	NA	NA	NA	NA	NA	NA	IN	NA	NA	NA	NA	NA	NA	NA	NA	↑
OUT	NA	NA	NA	NA	NA	NA	NA	NA	OUT	NA	NA	NA	NA	NA	NA	NA	NA	↓
<b>BUILT-IN DIGITAL I/O</b>				<b>INFORMATION</b>														
	2TR-2L	2TR-2R	AUX-5	AUX-6	AUX-7	AUX-8	PGM-L	PGM-R	DIPLL	CHMODE	DE EMP							
IN	UNLC	UNLC	ICOPY	ICOPY	UNLC	UNLC			DATA	EMPHASIS	OFF							
OUT			RDY	RDY	RDY	RDY	RDY	RDY	VALIDITY	FS	SRC							
									CRC	ORIGIN	OFF							
									AUDIO	DESTINATION								
CHANNEL	AUDIO	SNAPSHOT	CUE	AUTO-MATION	MACHINE CONTROL	SYSTEM	MASTER DROP IN											

## 5.2 Cascade



The MTBK-R109 board also enables cascade connection of two DMX-R100 units, creating a 96-channel mixer. This means that by using two DMX-R100 control surfaces, 48 faders are physically available for mixing, reducing the need to resort to repeated paging of channel faders. Cascade connection at double sample (96/88.2 kHz) rate is also supported but with half the number of channels on each mixer, so a total of 48 channels are available.

To activate cascade mode a switch on the MTBK-R109 cards has to be set to MASTER on one of the mixers and SUB on the other. Input of all 48 signals on the MADI card should be connected to the slave mixer. Signals 1-24 will then be sent through the MADI link to the master mixer and signals 25-48 will remain on the Sub mixer. The 48 output signals will come from the MADI out of the master mixer and feed the MADI device.

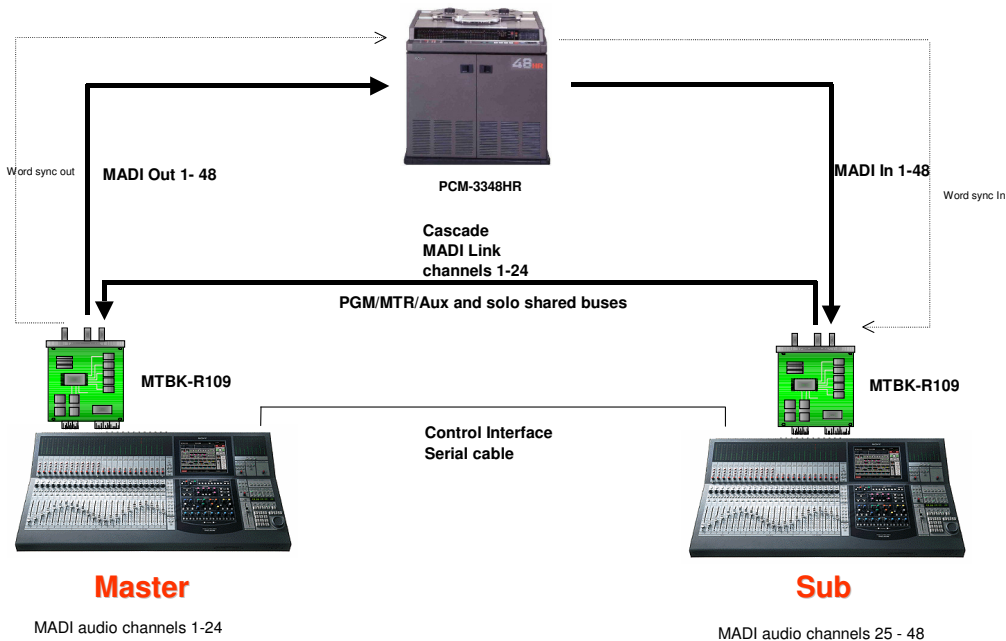

## Bus sharing

A further 24 buses are available between the Sub mixer and the Master mixer which are fed from the PGM, MTR, Aux and AFL/PFL buses. This allows signals in the sub mixer to be routed out and mixed together with signals on the Master mixer which can then be assigned out of the Master mixer to Aux outputs for foldback and reverbs, 8 buses for multitracks or PGM out for stereo or surround mastering devices.

All of these buses have an internal switch to select the bus linkage status (Linked or not) between the master mixer and sub mixer on an individual basis. The PGM, MTR and Aux busses of the master mixer can be time-aligned with those of the sub mixer, eliminating the need for manual intervention of timing delays. The AFL bus and solo logic of the master mixer are shared between the master and the sub, emulating the operation of a single 96-channel mixer.

On the Master mixer touch screen, a new CASCADE GUI is available to enable these links and to set the delay management. If the link is set to ON a delay will be set for that bus in the Master mixer to compensate for the delay of the signal from the Sub mixer sent on that shared bus.

- GUI setup option to allow Master and Sub busses to be linked by type:
  - PGM (Link On/Off selectable)
  - MTR (Link On/Off selectable)
  - AUX (Link On/Off selectable)
  - AFL is permanently shared
  - Solo logic is shared via PC port with serial cable

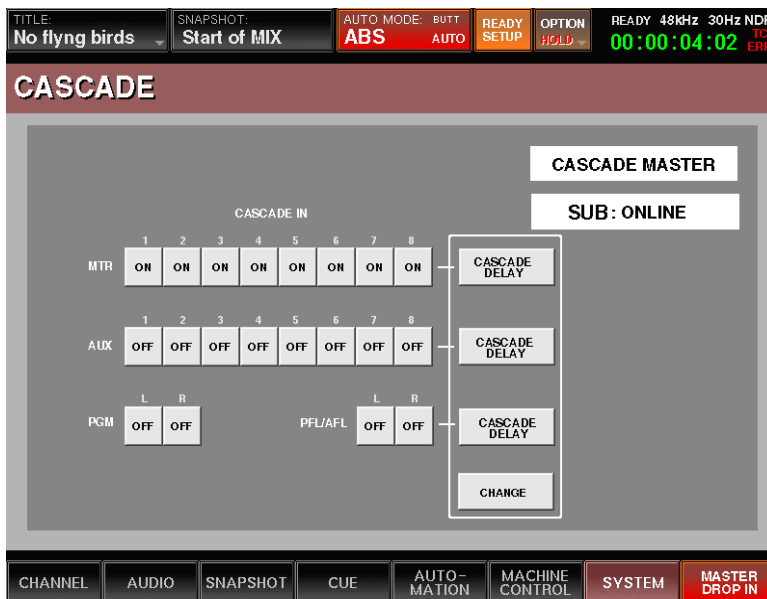

A serial PC port connection of the Master and Sub mixers is required to enable control functions of cascade mode (Mini DIN 8-pin) \*in cascade mode, PC port can not be used for any other communication mode.

When the delay management settings are changed, the Sub mixer will be re booted to adjust new settings.

Although the PGM, MTR & AUX Busses will be time-aligned when linked, Sub Bus Outputs assigned to the Master input Channels and other Inputs available on the I/O Matrix will not be time-aligned.

## 6. Hardware

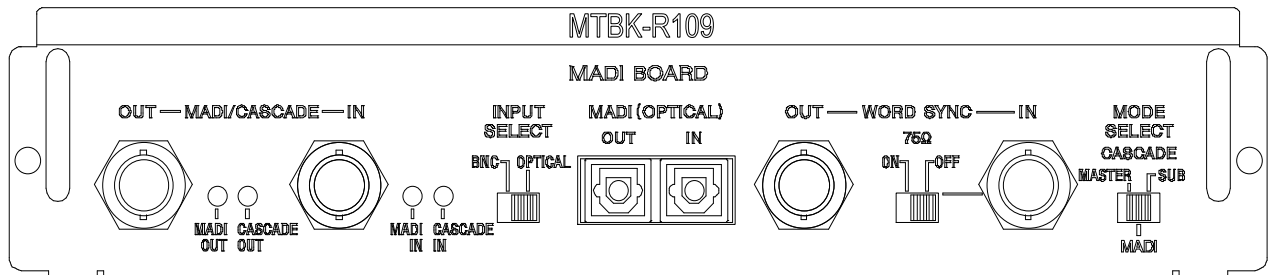

### 6.1 MADI Mode

Select the MODE SELECT switch to “MADI” on the MTBK-R109 to enable normal MADI input and output operation

MADI In signal

- The first 48 of the 56 MADI channels input to the DMX-R100
- Selectable BNC or Optical with external INPUT SELECT switch

MADI Out signal

- The 48 channels from DMX-R100 output to the 56 MADI channel slots. The last 8 channels (49-56) are inactive.
- The same signal is always sent out to both BNC and Optical.

### 6.2 CASCADE Mode

Cascade link between MASTER and SUB mixer can only be made with BNC connection

Master mixer

- Select the MODE SELECT switch to “Master”. The LED indicator “Cascade In” of the MADI board will illuminate.
- The cascaded bus signals, and MADI signals 1-24 from the sub DMX-R100 are fed to the MADI IN of the master mixer
- It is possible to monitor the buses of the Sub mixer on the Master mixer independently using the external source select on the master mixer.
- The same signal is always sent to both BNC and Optical connectors on the MADI output.

Sub mixer

- Select the MODE SELECT switch to “Sub”. The LED indicator “Cascade Out” of the MADI board will illuminate
- The MADI input is selectable to BNC or Optical
- The delay between Master MADI In and Sub MADI In is adjusted in the MADI board. This function is available only in Cascade mode.

### 6.3 Word Sync Input/Output

- Switchable 75Ω termination on/off
- A word sync signal on the input will also allow the DMX to be synchronized
- A word sync signal on the output is generated by the DMX

MADI Mode	MADI In	MADI Out
BNC	Y	Y
Optical	Y	Y

Cascade Mode	Master Cascade In	Master MADI Out	Sub MADI In	Sub Cascade Out
BNC	Y (for cascade)	Y	Y	Y (for cascade)
Optical	N	Y	Y	N

## 9. HARDWARE SPECIFICATIONS

### General

#### System

Audio Format : MADI (Multichannel Audio Digital Interface)

Sampling Frequency : AES10

1Fs : 48ch at 44.1, 48 kHz  $\pm$ 12.5%

Power requirement 2Fs : 24ch at 88.2, 96 kHz  $\pm$ 12.5% (DMX-R100 is 96kHz maximum)

: +3.3V (Maximum Current 500mA)

Power consumption +5V(Analog) (Maximum Current 1000mA)

Operating temperature : 5.7W (Typical)

Storage temperature : 5° to 35°C

#### Mass

Dimensions : -20° to 60°C

: 0.7 kg (including carton)

: 206(W) x 42.5(H) x 157(D) mm

### Audio Inputs

	Connector type	Signal Format	Transmission distance
MADI BNC IN	BNC	AES10 compliant	50m
MADI OPTICAL IN	SC Fiber	AES10 compliant (FDDI format)	500m (Tentative)

### Audio Outputs

	Connector type	Signal Format	Transmission distance
MADI BNC OUT	BNC	AES10 compliant	50m
MADI OPTICAL OUT	SC Fiber	AES10 compliant (FDDI format)	500m (Tentative)

### Sync

	Connector type	Signal Format	Impedance
Word Sync IN	BNC	Duty 50% (TTL Level)	75Ω ON/OFF
Word Sync OUT	BNC	Dutv 50% (TTL Level)	

# 10. DIMENSIONS

Unit: mm (inch)

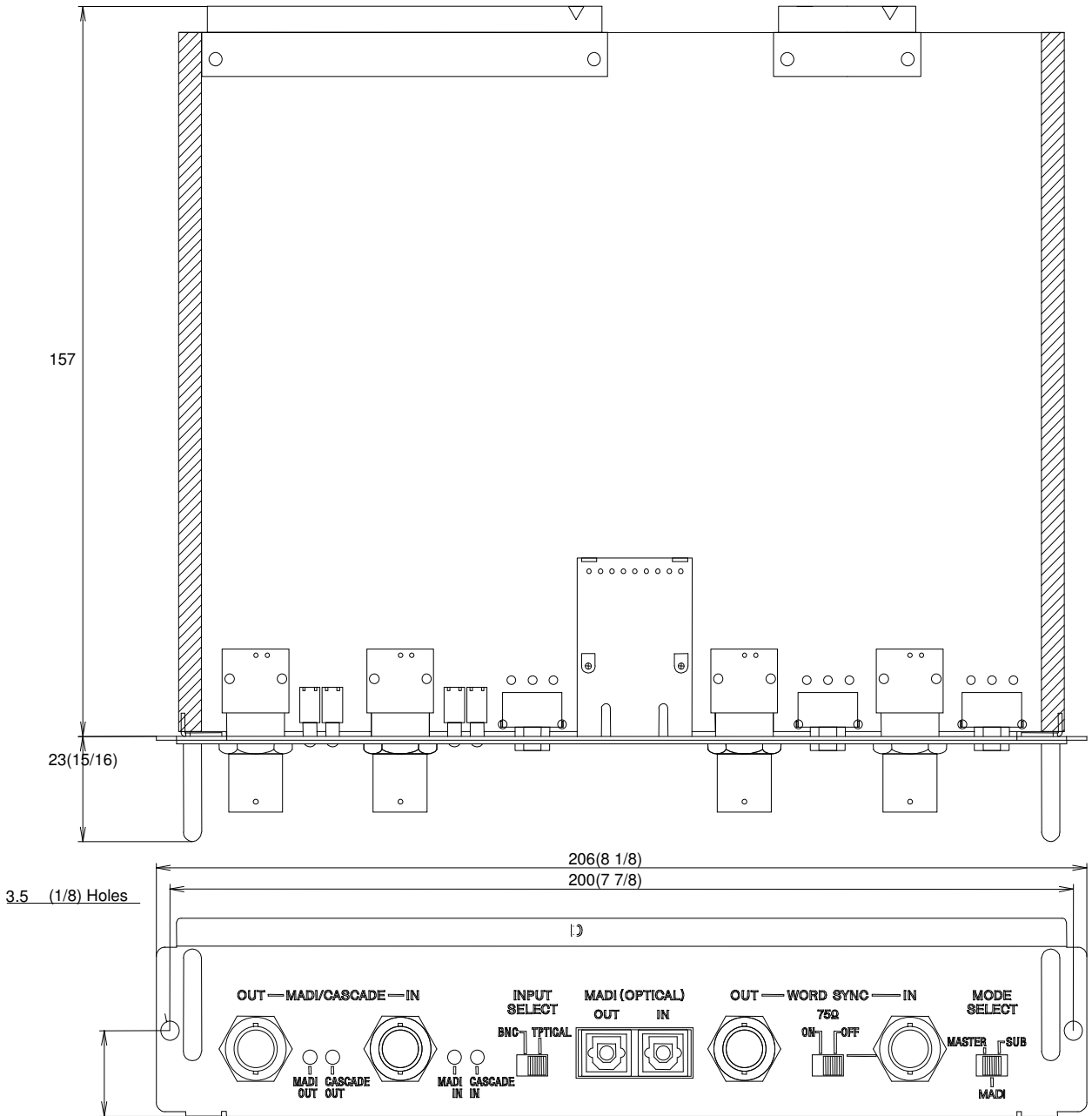



## 11. Conditions of use

- Setting the global SOLO mode (AFL/PFL/Solo) in cascade can only be done on the Master console
- Time code and reference signals must be fed into both the Master and the Sub mixers in parallel.
- Time alignment is assured only if a common time delay is introduced to all the channels of the given BUS type (e.g. MTR or Aux) of the Sub mixer in Cascade mode. Therefore time alignment is not possible if there are channels that have Cascade ON and others OFF within the same BUS type.
- After changing any of the switches on the MADI card (MASTER, MADI, SUB) the console must be re-booted.
- The PC serial cable must be connected to both mixers in cascade mode before power up sequence otherwise correct communication is not established.
- Cascaded mixer bus outputs appear as sources on the master mixer input routing GUI, so it is therefore possible to monitor cascade buses via the master mixers EXT MON section.
- In cascade mode both mixers must be set to the same sample rate.
- The title data created on V2.0 is compatible with V2.1 software
- A mixer running V1.1x software cannot be upgraded to V2.1 without first installing V2.0

At the time of printing this User Manual, the newest DMX-R100 software available was the DMX-R100 V2.23 software. If an older software version is installed in the DMX-R100, Merging recommends to update it to the latest version by contacting your local Sony Sales Representative or by connecting to the Sony official software download Web site:

<http://bssc.sel.sony.com/Professional/startpage.html>

or by connecting directly to the most recent downloads page for all Sony Pro Audio Software:

<http://bssc.sel.sony.com/Professional/webapp/Software?m=0&t=S&p=10>

## 12. System Example

### 12.1 - I/O Expansion. Music Recording System

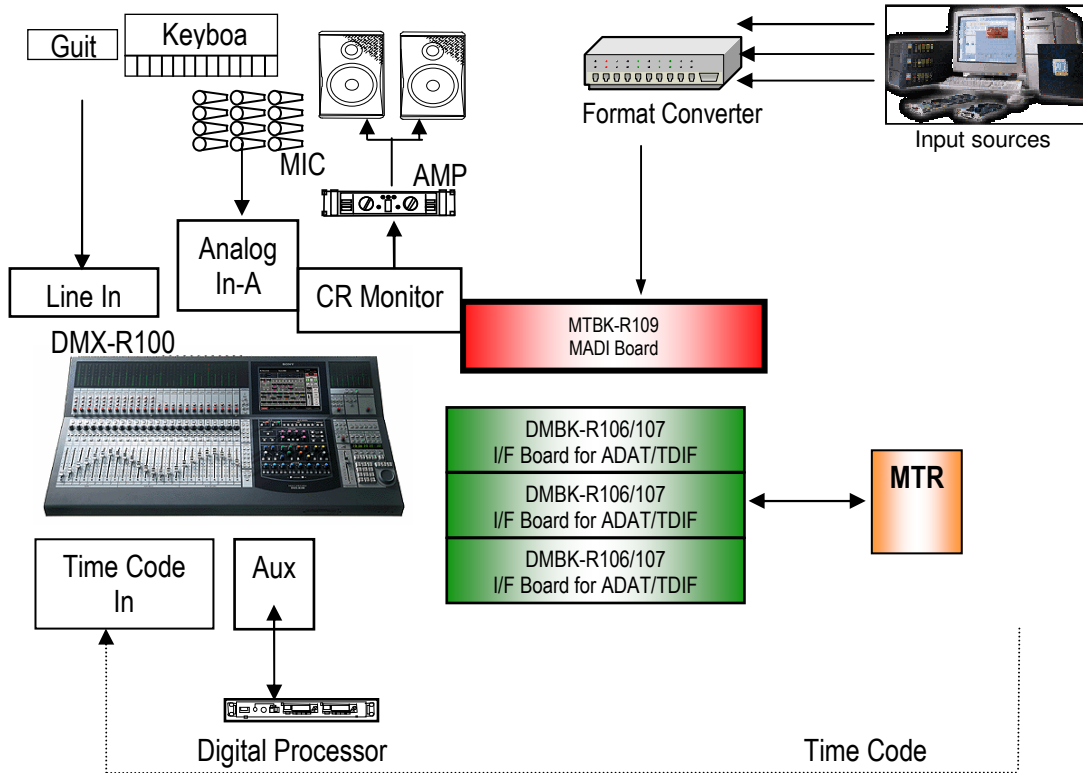

### 12.2 - CASCADE

#### Mix Down System

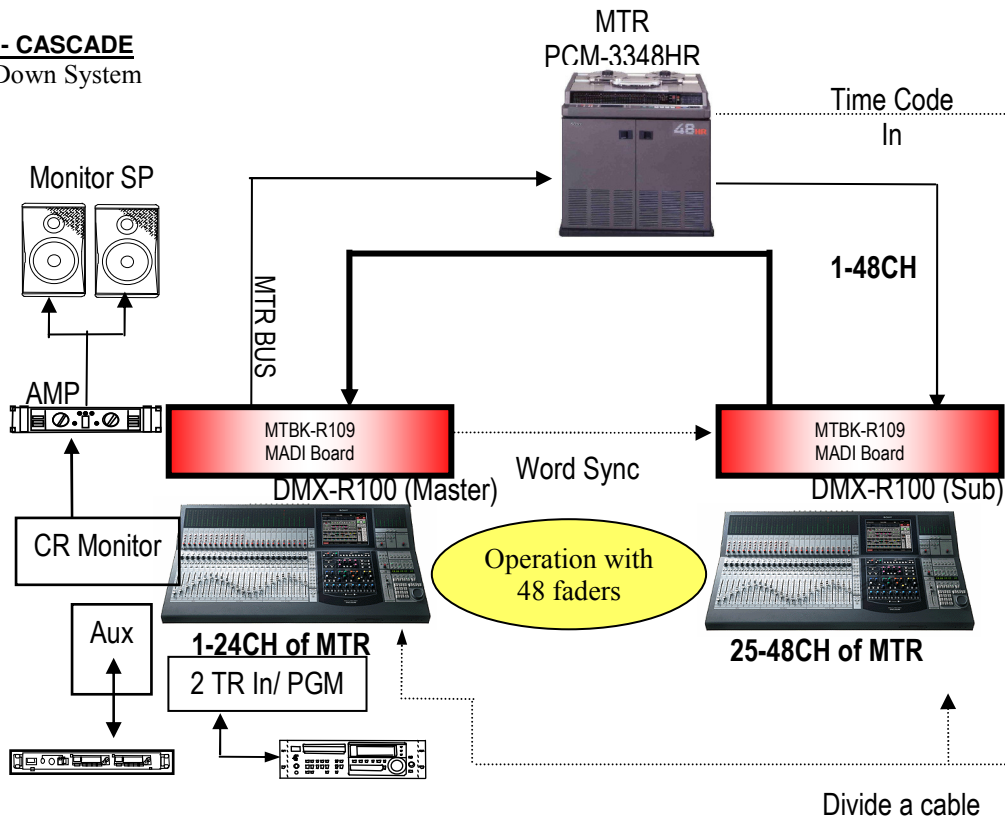

**12.3 - CASCADE**  
Music Recording System

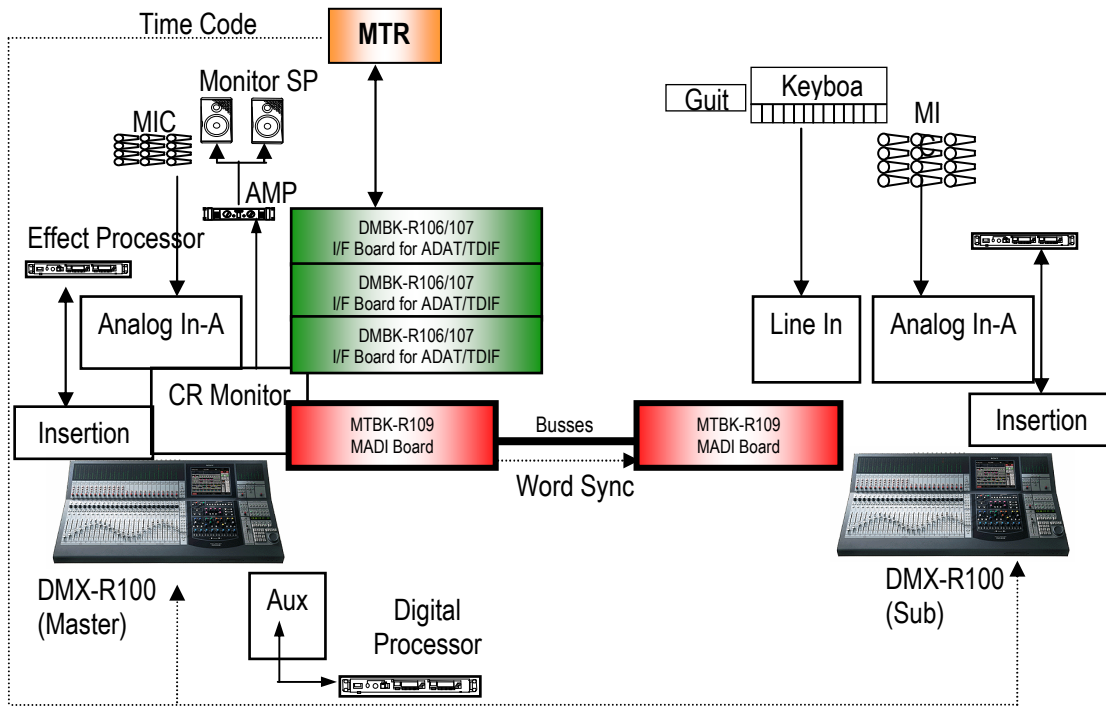

## 13 Contacting Merging

For all general or sales inquiries:

In Europe, Africa and Asia contact our Swiss Office:

Merging Technologies SA  
Le Verney  
1070 Puidoux  
Switzerland

Phone: +41 21 946 0444  
Fax: +41 21 946 0445

In the Americas, contact:

Merging USA  
43 Deerfield Road  
Portland, ME 04101-1805  
United States of America

Phone: +1 207 773 2424  
Fax: +1 207 773 2422

*For all documentation inquiries or suggestions for improvement: [www.merging.com](http://www.merging.com)*