

# VIP Relaxer Chairs Twin Pack

Assembly Instructions - Please keep for future reference

650/4744



## Dimensions

Width - 61.8cm

Depth - 101.5cm

Height - 71.8cm

**Important - Please read these instructions fully before starting assembly**

If you need help or have damaged or missing parts, call the **Customer Helpline: 08456 400800**

# User Manual

Fold the deckchair

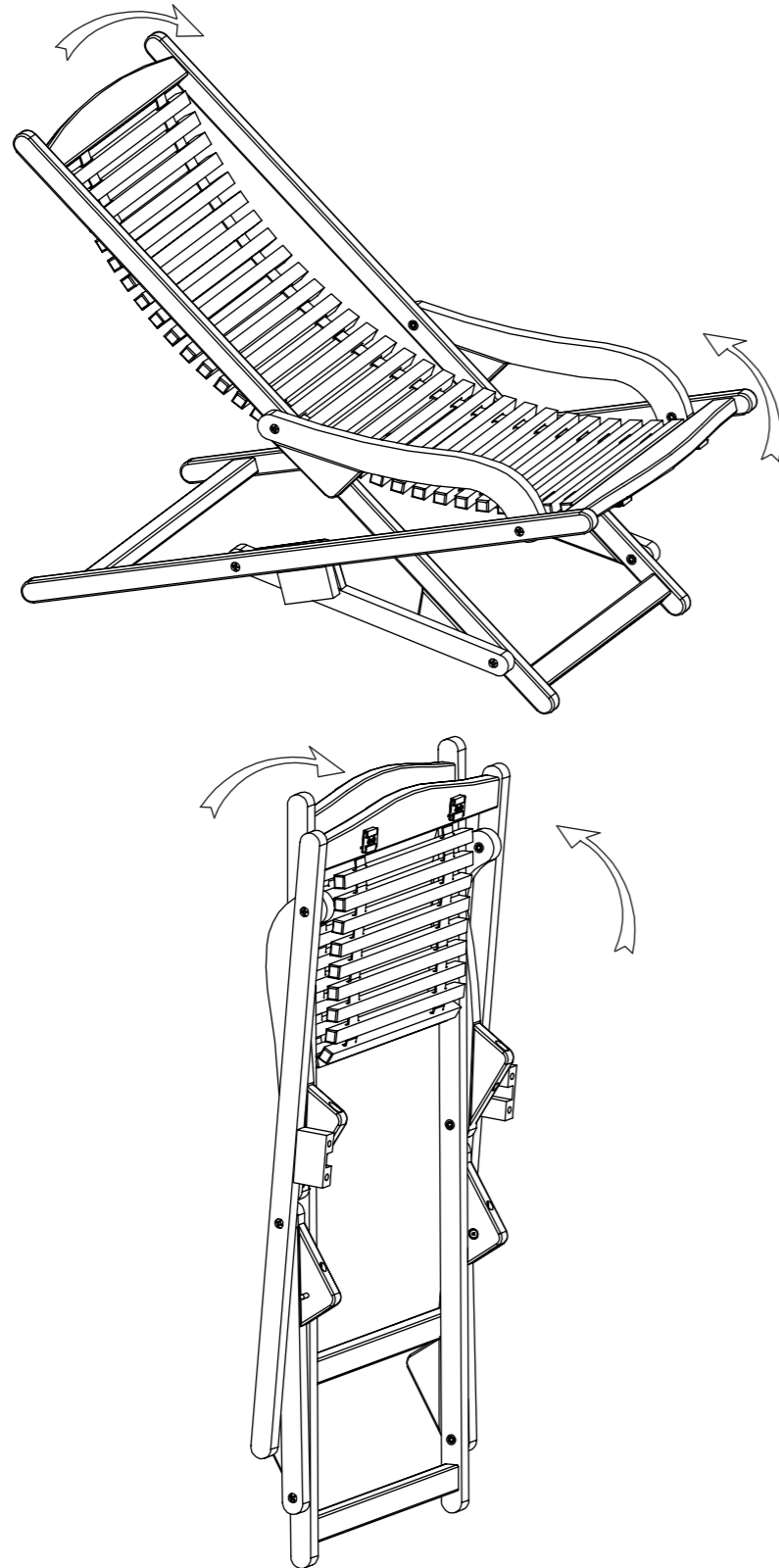

If you need help or have damaged or missing parts, call the **Customer Helpline: 08456 400800**

# Important, Retain For Future Reference: Read Carefully!

Care Instructions for wooden furniture

## IMPORTANT

As your furniture has been boxed since manufacture there may be a slight oil residue on the pieces which will dry when it is left to air. Care should be taken when assembling and using the furniture in the first couple of days particularly if light coloured clothes are worn. Hardwood has a varied texture which absorbs oil at different rates, this may mean there are some paler dry patches. If this is the case then apply a little oil as directed in the Care Instructions below.

## Use of Wood Furniture

This furniture has been made for the garden and is not suitable for indoor use or conservatories. If positioned on grass the legs may absorb moisture which could cause deterioration. The sunlight will make the colour of the wood mellow with time even if it is oiled. Never place hot dishes directly on to the wood as they will mark the surface. Wipe up spills immediately as the oiled surface is more susceptible to stains than a lacquered finish and the wood will absorb moisture causing the grain to rise slightly. Take care when moving furniture and never drag pieces as this will cause damage to the joints. To ensure the longevity of your garden furniture it is advised that it is covered when not in use and that it is stored in a garage or shed over the winter months. Ensure furniture is dry before storing.

## Care Instructions

In the first three months the furniture should be oiled monthly with a hardwood garden furniture oil using a lint free cloth, paying particular attention to the ends of the legs and slats as they are more absorbent. After the first three months, the furniture should be oiled once a year as it is brought out at the beginning of the spring summer season and whenever the surface is looking dry. The wood will gradually change colour to a silvery grey and the surface will become rough. Regular oiling will help to minimise cracking but won't eliminate it. Cracking of the timber does not affect the durability of the product. Do not use oils sold for cooking or eating as they will leave a sticky film. If the surface of the furniture becomes slightly stained or damaged with use, then it can often be removed by sanding gently with fine sandpaper then re-oiling. If the stain or damage is more serious then we recommend that professional help is obtained. Please check the fixings are all tight when you put the furniture out each year, as the wood will change size slightly with the different seasons.

Maximum safe weight of user is 110kgs.

Please retain for future reference.

If you need help or have damaged or missing parts, call the **Customer Helpline: 08456 400800**

# Marie Curie Cancer Care



*Devoted to Life*

## Marie Curie Cancer Care's sun CARE code

Take **CARE** in the sun:

- **Cover-up** by wearing a hat, t-shirt and sunglasses.
- **Avoid** the sun between the hours of 11.00 am to 3.00 pm when it is at its most dangerous.
- **Remember** to use a minimum of SPF 15 sunscreen, apply generously and reapply every two hours.
- **Ensure** that children are adequately protected because their skin is more delicate and prone to sunburn.

Time in the sun	Skin types				
	Very fair	Fair	Light	Medium	Dark
1 hour	SPF 15	SPF 15	SPF 15	SPF 15	SPF 15
2 hours	SPF 30	SPF 30	SPF 30	SPF 15	SPF 15
3 hours	SPF 50	SPF 30	SPF 30	SPF 15	SPF 15
4 hours	SPF 50	SPF 50	SPF 30	SPF 30	SPF 15
5 hours	SPF 50	SPF 50	SPF 50	SPF 30	SPF 15