

Instructions–Parts List



STATIONARY AIRLESS PAINT SPRAYER

30:1 President[®] Hydra–Spray[®]

306706W

Used for airless spray application of paints and other coatings from a 50–gallon drum.

3000 psi (21.0 MPa, 210 bar) Maximum Working Pressure
100 psi (0.7 MPa, 7 bar) Maximum Air Input Pressure



Important Safety Instructions
Read all warnings and instructions in this manual.
Save these instructions.

Model 231063, Series C

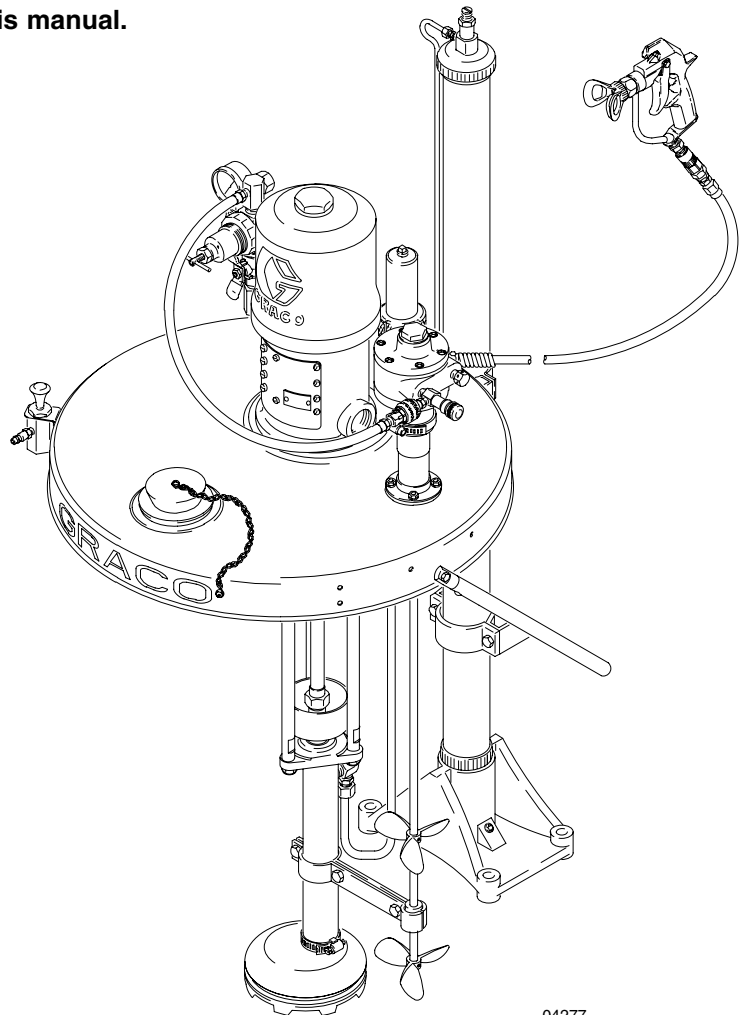

04277

PROVEN QUALITY. LEADING TECHNOLOGY.



HO03

Table of Contents

Warnings	3	Adjusting the Unit	8
Installation		Starting and Adjusting the Pump	9
Grounding	6	Shutdown and Care of the Pump	9
Positioning the Unit	6	Parts Drawing	10
System Accessories	6	Parts List	11
Connecting the Unit and Accessories	7	Technical Data	13
Operation/Maintenance		Warranty	14
Pressure Relief Procedure	8	Graco Information	14
Flushing the Pump	8		

WARNING



INSTRUCTIONS

EQUIPMENT MISUSE HAZARD

Equipment misuse can cause the equipment to rupture or malfunction and result in serious injury.

- This equipment is for professional use only.
- Read all instruction manuals, tags, and labels before operating the equipment.
- Use the equipment only for its intended purpose. If you are not sure, call your Graco distributor.
- Do not alter or modify this equipment. Use only Graco parts and accessories.
- Check equipment daily. Repair or replace worn or damaged parts immediately.
- Do not exceed the maximum working pressure of the lowest rated system component. See **Technical Data** on page 13 for the maximum working pressure of this equipment.
- Use fluids and solvents that are compatible with the equipment wetted parts. Refer to the **Technical Data** section of all equipment manuals. Read the fluid and solvent manufacturer's warnings.
- Do not use hoses to pull equipment.
- Route hoses away from traffic areas, sharp edges, moving parts, and hot surfaces. Do not expose Graco hoses to temperatures above 180°F (82°C) or below -40°F (-40°C).
- Wear hearing protection when operating this equipment.
- Do not lift pressurized equipment.
- Comply with all applicable local, state, and national fire, electrical, and safety regulations.

⚠ WARNING



SKIN INJECTION HAZARD

Spray from the gun, leaks, or ruptured components can inject fluid into your body and cause extremely serious injury, including the need for amputation. Fluid splashed in the eyes or on the skin can also cause serious injury.



- Fluid injected into the skin might look like just a cut, but it is a serious injury. **Get immediate surgical treatment.**
- Do not point the gun at anyone or at any part of the body.
- Do not put your hand or fingers over the spray tip.
- Do not stop or deflect leaks with your hand, body, glove or rag.
- Do not “blow back” fluid; this is not an air spray system.
- Always have the tip guard and the trigger guard on the gun when spraying.
- Check the gun diffuser operation weekly. Refer to the gun manual.
- Be sure the gun trigger safety operates before spraying.
- Lock the gun trigger safety when you stop spraying.
- Follow the **Pressure Relief Procedure** on page 8 if the spray tip clogs and before cleaning, checking, or servicing the equipment.
- Tighten all fluid connections before operating the equipment.
- Check the hoses, tubes, and couplings daily. Replace worn or damaged parts immediately. Do not repair high pressure couplings; you must replace the entire hose.
- Fluid hoses must have spring guards on both ends to help protect them from rupture caused by kinks or bends near the couplings.



MOVING PARTS HAZARD

- The air motor piston can pinch or amputate your fingers.
- The rotating blades of the agitator can pinch or amputate your fingers or other body parts and can cause splashing in the eyes or on the skin.
- Always shut off the agitator and disconnect the air line before adjusting the angle of the agitator, removing the agitator from the drum, or checking or repairing any part of the agitator.
- Keep clear of all moving parts when starting or operating the equipment.
- Before servicing the equipment, follow the **Pressure Relief Procedure** on page 8 to prevent the equipment from starting unexpectedly.

WARNING



FIRE AND EXPLOSION HAZARD

Improper grounding, poor ventilation, open flames or sparks can cause a hazardous condition and result in a fire or explosion and serious injury.



- Ground the equipment and the object being sprayed. Refer to **Grounding** on page 6.
- If there is any static sparking or you feel an electric shock while using this equipment, **stop spraying immediately**. Do not use the equipment until you identify and correct the problem.
- Provide fresh air ventilation to avoid the buildup of flammable fumes from solvents or the fluid being sprayed.
- Keep the spray area free of debris, including solvent, rags, and gasoline.
- Electrically disconnect all equipment in the spray area.
- Extinguish all open flames or pilot lights in the spray area.
- Do not smoke in the spray area.
- Do not turn on or off any light switches in the spray area while operating or if fumes are present.
- Do not operate a gasoline engine in the spray area.



TOXIC FLUID HAZARD

Hazardous fluid or toxic fumes can cause serious injury or death if splashed in the eyes or on the skin, inhaled, or swallowed.

- Know the specific hazards of the fluid you are using.
- Store hazardous fluid in an approved container. Dispose of hazardous fluid according to all local, state and national guidelines.
- Always wear protective eyewear, gloves, clothing, and respirator as recommended by the fluid and solvent manufacturer.

Installation

NOTES:

- Reference numbers and letters in parentheses in the text refer to the callouts in the figures and the parts drawing.
- Accessories are available from your Graco representative. If you supply your own accessories, be sure they are adequately sized and pressure-rated to meet the system's requirements.

Grounding

Proper grounding is an essential part of maintaining a safe system.

To reduce the risk of static sparking, the pump, mounting cover, and all electrically conductive objects or devices in the spray area **must** be properly grounded. Check your local electrical code for detailed grounding instructions for your area and type of equipment.

For a ground wire and clamp, order Part No. 237569.

Pump: Connect one end of a 12 ga (1.5 mm²) minimum ground wire (A) to the ground connector (B) on the pump. See Fig. 1. Connect the other end of the wire to a true earth ground.

Agitator and drum cover: Connect one end of ground wire (A) to ground connector (B) on rim of drum cover. See Fig. 1. Connect other end of ground wire to true earth ground.

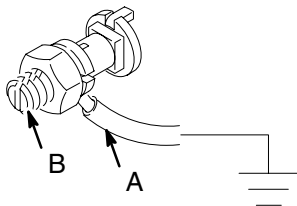

Fig. 1

Air and fluid hoses: Use only electrically conductive hoses with 500 ft (150 m) maximum combined hose length to ensure grounding continuity.

Air compressor: Follow manufacturer's recommendations.

Spray gun: Connect to a properly grounded fluid hose and pump.

Object being sprayed: Follow your local code.

Fluid supply container: Follow your local code.

Solvent pails used when flushing: Follow your local code. Use only metal pails, which are conductive, placed on a grounded surface. Do not place the pail on a nonconductive surface, such as paper or cardboard, which interrupts the grounding continuity.

To maintain proper grounding continuity when flushing or relieving pressure, always hold the metal part of the spray gun firmly to the side of a grounded metal pail, then trigger the gun.

Positioning the Unit

- Select a convenient location for the unit. The air valves for the pump (37), agitator (5), and elevator (3) must be fully accessible.
- The elevator needs 9 ft (2.8 m) of overhead clearance. Bolt the elevator to the floor as shown in the elevator instruction manual 306287.

System Accessories

! WARNING

A bleed-type master air valve (A) and a fluid drain valve (M) are required in your system. These accessories help reduce the risk of serious injury, including fluid injection and splashing of fluid in the eyes or on the skin, and injury from moving parts if you are adjusting or repairing the pump or agitator.

The bleed-type master air valve relieves air trapped between this valve and the pump after the air is shut off. Trapped air can cause the pump to cycle unexpectedly. Locate the valve close to the pump. Order Part No. 107141.

The fluid drain valve assists in relieving fluid pressure in the displacement pump, hose, and gun. Triggering the gun to relieve pressure may not be sufficient. Order Part No. 210658.

Installation

The installation shown in Fig. 2 is only a guide for selecting and installing system components and accessories. Contact your Graco distributor for assistance in designing a system to suit your particular needs.

Connecting the Unit and Accessories

- Ground the unit as described in **Grounding** on page 6.
- Connect a 1/2 in. (13 mm) minimum ID, grounded air supply hose to the 1/2 in. npt(f) air inlet swivel (32).
- The main air supply must include a bleed-type master air valve (A) for shutting off air pressure to the unit.
- The fluid line must include a fluid drain valve (not shown), which helps relieve fluid pressure in the hose and gun.
- You should install an air line filter (B) to remove dirt and moisture from the air supply.

To order an air line filter, order by Part No. from the list below:

203421 1/2" npt inlet and outlet, with gauge, 200 psi (1.4 MPa, 14 bar) maximum working pressure. See instruction manual 306393.

204856 1/2" npt inlet and outlet, without gauge, 200 psi (1.4 MPa, 14 bar) maximum working pressure. See instruction manual 306393.

- Downstream from the air filter, you should install an air line lubricator (C) for automatic air motor lubrication. To order a 1/2" npt(f) inlet and outlet, 250 psi (1.4 MPa, 14 bar) maximum working pressure airline lubricator, order Part No. 214848. For more information, see instruction manual 307316.
- Connect the fluid hose (7) to the nipple on the outlet filter (17). Do not use thread sealer. Connect the spray gun (20) to the swivel (5). See page 10.

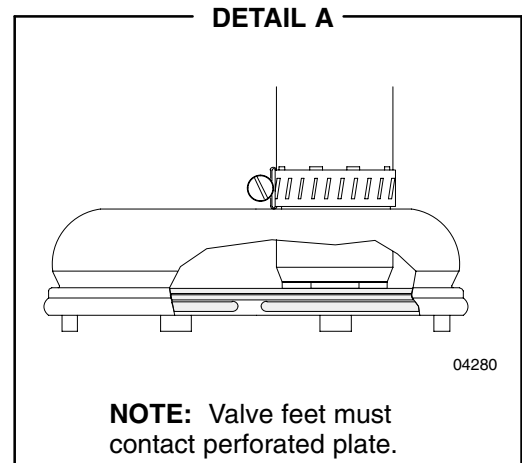
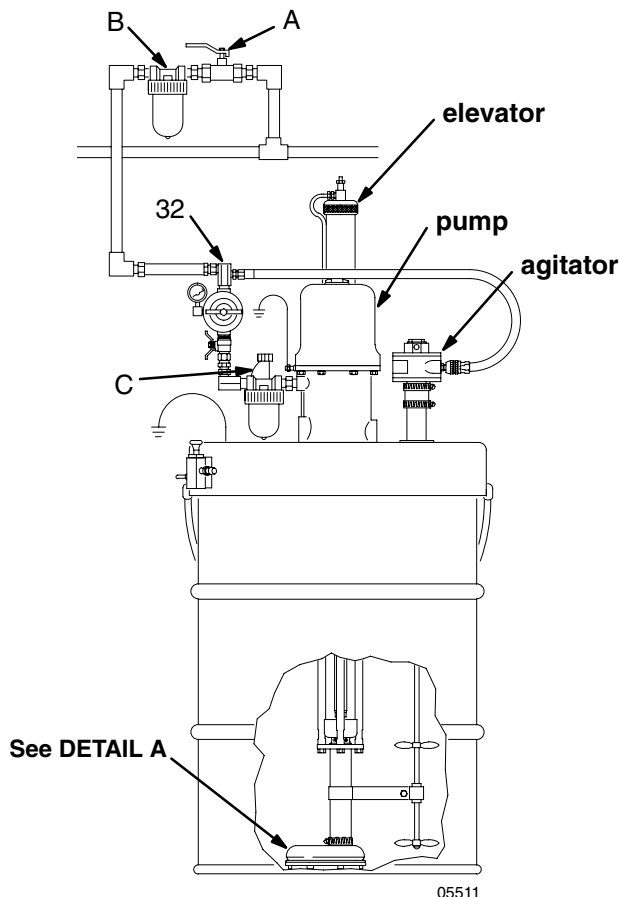
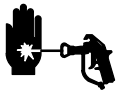

Fig. 2

Operation/Maintenance

Pressure Relief Procedure

WARNING



SKIN INJECTION HAZARD

The system pressure must be manually relieved to prevent the system from starting or spraying accidentally. Fluid under high pressure can be injected through the skin and cause serious injury. To reduce the risk of an injury from injection, splashing fluid, or moving parts, follow the **Pressure Relief Procedure** whenever you

- Are instructed to relieve the pressure
- Stop spraying
- Check or service any of the system equipment
- Install or clean the spray tips

1. Lock the gun trigger safety.
2. Shut off the air supply to the pump.
3. Close the bleed-type master air valve (required in your system).
4. Unlock the gun trigger safety.
5. Hold a metal part of the gun firmly to the side of a grounded metal pail, and trigger the gun to relieve pressure.
6. Lock the gun trigger safety.
7. Open the drain valve (required in your system), and have a container ready to catch the drainage.
8. Leave the drain valve open until you are ready to spray again.

If you suspect that the spray tip or hose is completely clogged, or that pressure has not been fully relieved after following the steps above, very slowly loosen the tip guard retaining nut or hose end coupling and relieve the pressure gradually. Then loosen it completely. Then clear the tip or hose.

Flushing the Pump

WARNING



FIRE AND EXPLOSION HAZARD

Before flushing, read the section **FIRE AND EXPLOSION HAZARD** on page 5. Be sure the entire system and flushing pails are properly grounded. Refer to **Grounding** on page 6.

Flush the pump before first use. The pump is tested with lightweight oil, which is left in to protect the

pump parts. If the fluid you are using may be contaminated by the oil, flush it out with a compatible solvent.

WARNING

To reduce the risk of serious injury whenever you are instructed to relieve pressure, always follow the **Pressure Relief Procedure** at left.

To flush the pump, do the following procedure:

1. **Relieve the pressure.**
2. Remove the spray tip from the gun.
3. Hold a metal part of the gun firmly to the side of a grounded *metal* pail.
4. Start the pump. Always use the lowest possible fluid pressure when flushing.
5. Trigger the gun.
6. Flush the system until clear solvent flows from the gun.
7. **Relieve the pressure.**

CAUTION

Never leave water or water-based fluid in the pump overnight. First, flush with water or a compatible solvent, then with mineral spirits. Relieve the pressure, but leave the mineral spirits in the pump to protect the parts from corrosion.

Adjusting the Unit

You must adjust the elevator to ensure that the cover is supported by the drum.

CAUTION

Shortened or recycled drums may cause the pump or agitator to bottom out in the drum, causing damage. Contact your fluid supplier to order a standard size drum.

NOTE: The 100-mesh intake screen (9) should be replaced by the coarser 50-mesh screen when using large-orifice spray tips.

1. Connect the air supply. Raise the elevator by pulling out the knob of the elevator's push/pull air valve.
2. Place a drum of fluid under the cover, against the elevator base.

Operation/Maintenance

3. Push in on the air valve knob to lower the elevator, so the cover (A) rests on the top lip of the drum. The support clamp (K) recesses must be tight against the elevator riser tube. The pump intake valve feet (B) must contact and support the perforated plate (9) as shown in Fig. 2.
4. Raise the elevator 1/4" (6.4 mm), then tighten the support clamp screws. This ensures that the cover rests on the drum lip when the elevator is in the lowered position.
5. Adjust the restrictor valve screw to control the speed of raising and lowering the unit. Turn the restrictor screw clockwise to decrease the air pressure and counterclockwise to increase air pressure to the elevator. Lock the screw's position with the locknut when the adjustment is completed.
6. Unscrew the filter bowl and remove the filter screen. Replace the bowl. Flush the unit until clear solvent comes from the gun, then reinstall the filter screen.
7. Before operation, ensure that all fasteners and tube connections are tightened securely.

Starting and Adjusting the Pump

1. Lower the pump into the fluid supply drum.
2. Close the air regulator (F).
3. Open the pump's bleed-type master air valve (E).
4. Hold a metal part of the gun (S) firmly to the side of a grounded metal pail and hold the trigger open.
5. Slowly open the regulator until the pump starts.
6. Cycle the pump slowly until all air is pushed out and the pump and hoses are fully primed.
7. Release the gun trigger and lock the trigger safety. The pump should stall against pressure.
8. If the pump fails to prime properly, open the drain valve (M). Use the drain valve as a priming valve until the fluid flows from the valve. Close the valve.

NOTE: When changing fluid containers with the hose and gun already primed, open the drain valve (M) to help prime the pump and vent air before it enters the hose. Close the drain valve when all air is eliminated.

CAUTION

Do not allow the pump to run dry. It will quickly accelerate to a high speed, causing damage. If your pump is running too fast, stop it immediately and check the fluid supply. If the container is empty and air has been pumped into the lines, refill the container and prime the pump and the lines, or flush and leave it filled with a compatible solvent. Eliminate all air from the fluid system.

9. With the pump and lines primed, and with adequate air pressure and volume supplied, the pump will start and stop as you open and close the gun. In a circulating system, the pump will speed up or slow down on demand, until the air supply is shut off.

WARNING

COMPONENT RUPTURE HAZARD



To reduce the risk of overpressurizing your system, which could cause component rupture and serious injury, *never exceed the specified Maximum Incoming Air Pressure to the pump.* (see **Technical Data** on page 13.)

10. Use the air regulator (F) to control pump speed and fluid pressure. Always use the lowest air pressure necessary to get the desired results. Higher pressures cause premature tip and pump wear.

Shutdown and Care of the Pump

WARNING

To reduce the risk of serious injury whenever you are instructed to relieve pressure, always follow the **Pressure Relief Procedure** on page 8.

For overnight shutdown, stop the pump at the bottom of its stroke to prevent fluid from drying on the exposed displacement rod and damaging the throat packings. **Relieve the pressure.**

Always flush the pump before the fluid dries on the displacement rod. See **Flushing** on page 8.

Parts Drawing

Model 231063, Series C, 30:1 President® Hydra-Spray®

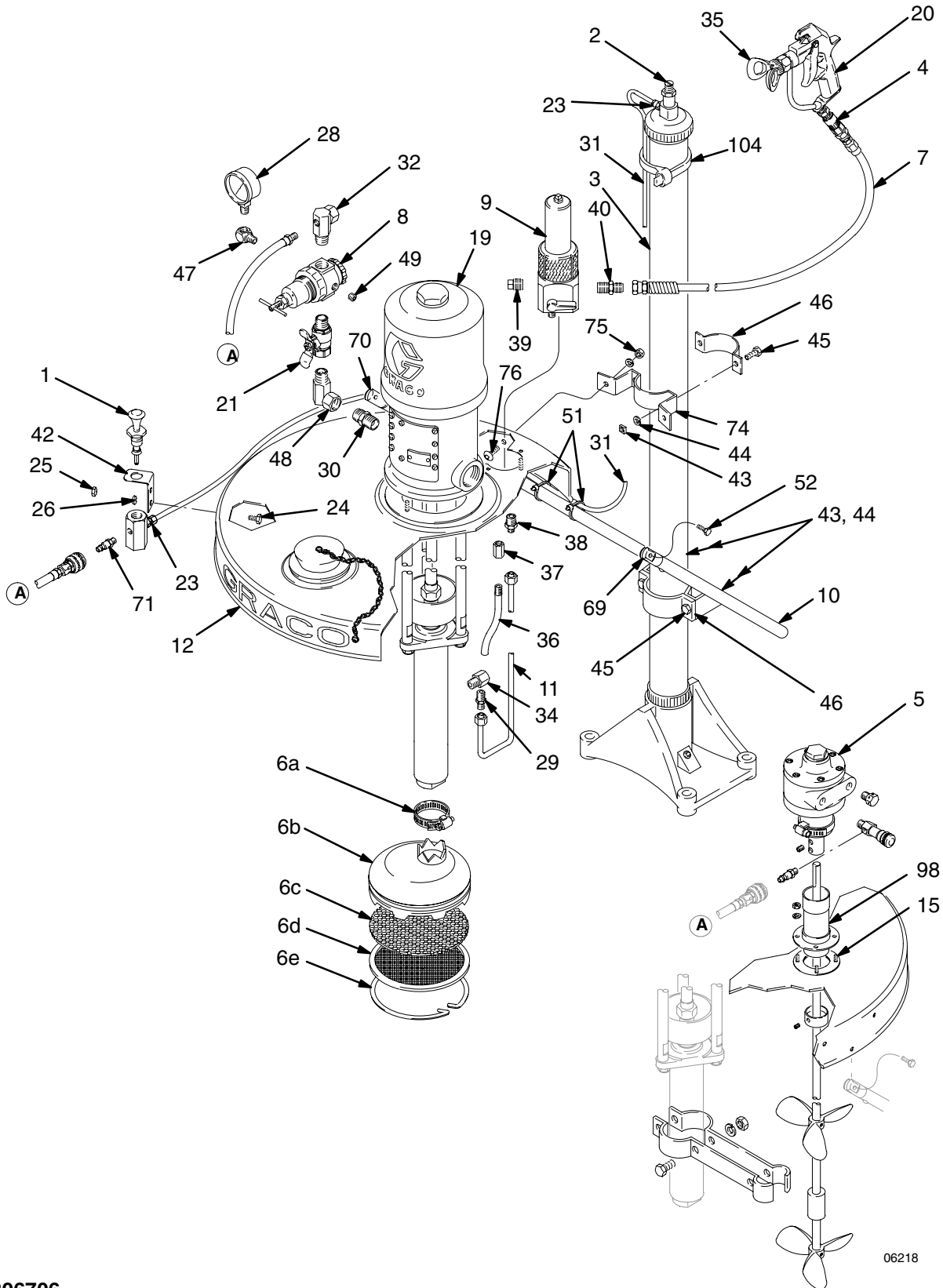

Parts List

Model 231063, Series C, 30:1 President® Hydra-Spray®

Ref. No.	Part No.	Description	Qty.	Ref. No.	Part No.	Description	Qty.
1	202295	VALVE, push-pull <i>See 306287 for parts.</i>	1	29	101909	CONNECTOR, male; 1/2–28 x 3/8" tube; 1/4 npt(m)	1
2	203743	VALVE, restrictor <i>See 306287 for parts.</i>	1	30	158491	NIPPLE; 1/2" npt	1
3	204385	ELEVATOR <i>See 306287 for parts.</i>	1	31		TUBE; nylon; 1/4 in. (6.4mm) OD, 250 psi (1.7 MPa, 17 bar) working pressure, 7 ft. (213 cm)	1
4	204940	SWIVEL <i>See 306861 for parts.</i>	1	32	161262	MANIFOLD, air	1
5	204995	AGITATOR <i>See 306459 for parts.</i>	1	33	162746	SCREEN, 50 mesh; brass; <i>(not shown) Optional—can be used in place of item 6d.</i>	1
6	205306	INTAKE SCREEN ASSEMBLY <i>Includes items 6a to 6e.</i>	1	34	164259	ELBOW; 1/4 npt(f) x 3/8 npt(m)	1
6a	101368	. CLAMP	1	35		TIP, spray; customer's choice	1
6b	164178	. HOUSING, screen	1	36	164558	TUBE, drain	1
6c	162363	. PLATE	1	37	113093	ADAPTER; 1/4 npt (fbe)	1
6d	162362	. SCREEN, 100 mesh	1	38	101958	FITTING, tube; 9/16–18 x 3/8" OD tube; 3/8 npt(m)	1
6e	162416	. RING, retaining	1	39	104663	PLUG, pipe, sq hd; 3/4 npt	1
7	223540	HOSE, static free; nylon; 1/4" (6 mm) ID; 1/4 npsm (fbe); 25 ft (7.6 m) long, with spring guard	1	40	162449	NIPPLE; 1/2 x 1/4 npt	1
8	104266	REGULATOR, air	1	42	190231	BRACKET, valve	1
9	214724	FILTER, fluid <i>See 307296 for parts.</i>	1	43	112900	NUT, square; 5/16"	4
10	202776	BRACE, support	1	44	112904	WASHER, lock, spring; 5/16"	6
11	207699	TUBE, riser	1	45	114251	SCREW, cap, hex hd; 5/16–18 x 3/4" (19 mm)	4
12	237308	COVER, drum <i>See 308466 for parts.</i>	1	46	190181	BRACKET, riser tube	2
15	100268	SCREW, rd hd, machine; 10–24 x 3/8" (10 mm)	2	47	187357	ELBOW, street	1
19	221075	30:1 PRESIDENT PUMP <i>See 306981 for parts.</i>	1	48	155470	SWIVEL; 1/2" npt(m) x 1/2 npsm(f)	1
20	XTR501	SPRAY GUN, airless <i>See 308236 for parts.</i>	1	49	100721	PLUG, pipe	1
21	107142	VALVE, air, bleed-type	1	50	104765	PLUG, pipe <i>(not shown)</i>	2
23	113208	FITTING, tube	2	51	103473	STRAP, tie, wire	2
24	112896	SCREW, cap, hex hd; 1/4–20 x 1/2" (13 mm)	4	52	112895	SCREW, cap, hx hd, 1/4 x 20	2
25	104121	NUT, hex; 1/4–20	2	53	101643	DRUM, fiber <i>(not shown)</i>	1
26	104123	WASHER, spring lock; 1/4" size	6	69	190272	STUD, brace	1
28	100960	GAUGE, air pressure	1	70	190273	STUD, brace	1
				71	169969	FITTING, line, air	1
				74	190187	BRACKET, support, rear	1
				75	108946	NUT, hex	2
				76	112944	SCREW, cap, btn hd	2
				98	204635	GUIDE, agitator	1
				104	103546	STRAP, tie	3

Technical Data

Ratio	30:1
Maximum fluid working pressure	3000 psi (21 MPa, 207 bar)
Maximum air input pressure	100 psi (0.7 MPa, 7 bar)
Recommended pump speed for continuous operation	60 cycles per min
Maximum flow	3.8 liters/min (1.0 gpm) at 60 cycles/min
Height	lowered: 57 in. (1.5 m) raised: 96 in. (2.4 m)
Width	17 in. (685 mm)
Depth	30 in. (760 mm)
Weight	approx. 240 lb (109 kg)
Wetted parts	carbon steel; alloy steel; zinc and nickel plating; ductile iron; 304, 440 and 17-4 PH grades of stainless steel; tungsten carbide; PTFE; leather

Graco Standard Warranty

Graco warrants all equipment manufactured by Graco and bearing its name to be free from defects in material and workmanship on the date of sale to the original purchaser for use. With the exception of any special, extended, or limited warranty published by Graco, Graco will, for a period of twelve months from the date of sale, repair or replace any part of the equipment determined by Graco to be defective. This warranty applies only when the equipment is installed, operated and maintained in accordance with Graco's written recommendations.

This warranty does not cover, and Graco shall not be liable for general wear and tear, or any malfunction, damage or wear caused by faulty installation, misapplication, abrasion, corrosion, inadequate or improper maintenance, negligence, accident, tampering, or substitution of non-Graco component parts. Nor shall Graco be liable for malfunction, damage or wear caused by the incompatibility of Graco equipment with structures, accessories, equipment or materials not supplied by Graco, or the improper design, manufacture, installation, operation or maintenance of structures, accessories, equipment or materials not supplied by Graco.

This warranty is conditioned upon the prepaid return of the equipment claimed to be defective to an authorized Graco distributor for verification of the claimed defect. If the claimed defect is verified, Graco will repair or replace free of charge any defective parts. The equipment will be returned to the original purchaser transportation prepaid. If inspection of the equipment does not disclose any defect in material or workmanship, repairs will be made at a reasonable charge, which charges may include the costs of parts, labor, and transportation.

THIS WARRANTY IS EXCLUSIVE, AND IS IN LIEU OF ANY OTHER WARRANTIES, EXPRESS OR IMPLIED, INCLUDING BUT NOT LIMITED TO WARRANTY OF MERCHANTABILITY OR WARRANTY OF FITNESS FOR A PARTICULAR PURPOSE.

Graco's sole obligation and buyer's sole remedy for any breach of warranty shall be as set forth above. The buyer agrees that no other remedy (including, but not limited to, incidental or consequential damages for lost profits, lost sales, injury to person or property, or any other incidental or consequential loss) shall be available. Any action for breach of warranty must be brought within two (2) years of the date of sale.

Graco makes no warranty, and disclaims all implied warranties of merchantability and fitness for a particular purpose in connection with accessories, equipment, materials or components sold but not manufactured by Graco. These items sold, but not manufactured by Graco (such as electric motors, switches, hose, etc.), are subject to the warranty, if any, of their manufacturer. Graco will provide purchaser with reasonable assistance in making any claim for breach of these warranties.

In no event will Graco be liable for indirect, incidental, special or consequential damages resulting from Graco supplying equipment hereunder, or the furnishing, performance, or use of any products or other goods sold hereto, whether due to a breach of contract, breach of warranty, the negligence of Graco, or otherwise.

FOR GRACO CANADA CUSTOMERS

The parties acknowledge that they have required that the present document, as well as all documents, notices and legal proceedings entered into, given or instituted pursuant hereto or relating directly or indirectly hereto, be drawn up in English. Les parties reconnaissent avoir convenu que la rédaction du présente document sera en Anglais, ainsi que tous documents, avis et procédures judiciaires exécutés, donnés ou intentés à la suite de ou en rapport, directement ou indirectement, avec les procédures concernées.

Graco Information

For the latest information about Graco products, visit www.graco.com.

TO PLACE AN ORDER, contact your Graco distributor, or call one of the following numbers to identify the distributor closest to you:

1-800-328-0211 Toll Free

612-623-6921

612-378-3505 Fax

All written and visual data contained in this document reflects the latest product information available at the time of publication. Graco reserves the right to make changes at any time without notice.

This manual contains English. MM 306706

Graco Headquarters: Minneapolis

International Offices: Belgium, China, Japan, Korea

GRACO INC. P.O. BOX 1441 MINNEAPOLIS, MN 55440-1441

Copyright 1984, Graco Inc. is registered to ISO 9001

www.graco.com

Revised 04/2009