

OPERATION MANUAL

FA-10DCCRU Remote Control Unit

2nd Edition – Rev. 1

Software Version 2.10 – Higher



Edition Revision History

Edit.	Rev.	Date	Description	Section/Page
1	-	2014/06/30	1 st Edition	
2	-	2014/12/17	Supported FA-505 units. Changed event save/load procedure.	7
2	1	2015/05/29	Changed default IP address to 192.168.0.101. Factual errors corrected	5-2, 5-6



Precautions

Important Safety Warnings



[Power]

 Caution	Operate unit only at the specified supply voltage.
	Disconnect the power cord via the power plug only. Do not pull on the cable portion.
 Stop	Do not place or drop heavy or sharp-edged objects on the power cord. A damaged cord can cause fire or electrical shock hazards. Regularly check the power cord for excessive wear or damage to avoid possible fire / electrical hazards.

[Grounding]

 Caution	Ensure the unit is properly grounded at all times to prevent electrical shock.
 Hazard	Do not ground the unit to gas lines, units, or fixtures of an explosive or dangerous nature.
 Caution	Ensure the power cord is firmly plugged into the AC outlet.



[Operation]

 Hazard	Do not operate the unit under hazardous or potentially explosive atmospheric conditions. Doing so could result in fire, explosion, or other hazardous results.
 Hazard	Do not allow liquids, metal pieces, or other foreign materials to enter the unit. Doing so could result in fire, other hazards, or a unit malfunction.
	If a foreign material does enter the unit, turn the power off and immediately disconnect the power cord. Remove the material and contact an authorized service representative if damage has occurred.

[Transportation]

 Caution	Handle with care to avoid impact shock during transit, which may cause malfunction. When you need to transport the unit, use the original or suitable alternative packing material.
------------------------------------------------------------------------------------------------	--------------------------------------------------------------------------------------------------------------------------------------------------------------------------------------------

[Circuitry Access]

	<p>Do not remove covers, panels, casing, or access the circuitry with power applied to the unit. Turn the power off and disconnect the power cord prior to removal. Internal servicing / adjustment of unit should only be performed by qualified personnel.</p>
 Stop	<p>Do not touch any parts / circuitry with a high heat factor. Capacitors can retain enough electric charge to cause mild to serious shock, even after the power has been disconnected. Capacitors associated with the power supply are especially hazardous.</p>
 Hazard	<p>Unit should not be operated or stored with cover, panels, and / or casing removed. Operating the unit with circuitry exposed could result in electric shock / fire hazards or a unit malfunction.</p>

[Potential Hazards]

 Caution	<p>If abnormal odors or noises are noticed coming from the unit, immediately turn the power off and disconnect the power cord to avoid potentially hazardous conditions. If problems similar to the above occur, contact an authorized service representative before attempting to operate the unit again.</p>
----------------------------------------------------------------------------------------------	-----------------------------------------------------------------------------------------------------------------------------------------------------------------------------------------------------------------------------------------------------------------------------------------------------------------------

[Rack Mount Brackets, Ground Terminal, and Rubber Feet]

 Caution	<p>To rack-mount or ground the unit, or to install rubber feet, do not use screws or materials other than those supplied. Doing so may cause damage to the internal circuits or components of the unit. If you remove the rubber feet that are attached to the unit, do not reinsert the screws that secure the rubber feet.</p>
-----------------------------------------------------------------------------------------------	------------------------------------------------------------------------------------------------------------------------------------------------------------------------------------------------------------------------------------------------------------------------------------------------------------------------------------------------

[Consumables]

 Caution	<p>Consumable items that are used in the unit must be periodically replaced. For further details on which parts are consumables and when they should be replaced, refer to the specifications at the end of the Operation Manual. Since the service life of the consumables varies greatly depending on the environment in which they are used, such items should be replaced at an early date. For details on replacing consumable items, contact your dealer.</p>
------------------------------------------------------------------------------------------------	---------------------------------------------------------------------------------------------------------------------------------------------------------------------------------------------------------------------------------------------------------------------------------------------------------------------------------------------------------------------------------------------------------------------------------------------------------------------

Upon Receipt

Unpacking

FA-10DCCRU units and their accessories are fully inspected and adjusted prior to shipment. Operation can be performed immediately upon completing all required connections and operational settings.

Check your received items against the packing lists below. Check to ensure no damage has occurred during shipment. If damage has occurred, or items are missing, inform your supplier immediately.

ITEM	QTY	REMARKS
FA-10DCCRU	1	
AC Cord	1 set	(Including an AC cord retaining clip)
Rack Mount Brackets	1 set	EIA standard type
CD-ROM	1	Installation Disc User manual (PDF) included
Quick Setup Guide	1	

Installing the AC Cord Retaining Clip

Secure the AC cord with the supplied ladder strap/retaining clip assembly to prevent accidental removal from the unit.

◆ Installing the clip

- 1) Wrap the retaining clip around the AC cord. (with the anchor of the ladder strap toward the unit.)
- 2) Insert the anchor into the hole next to the AC IN socket.
- 3) Lightly fasten the clip around the AC cord.
- 4) Plug in the power cord.
- 5) Slide the clip on the ladder strap toward the plug.
- 6) Fasten the clip tightly.
- 7) Gently pull on the AC cord to ensure it is secured.

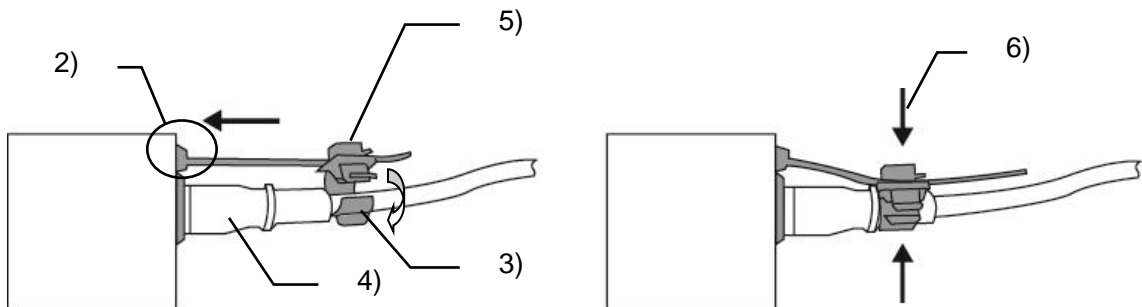

◆ Unplugging the AC cord

- 1) Push the tab on the retaining clip up to unfasten the clip.
- 2) Push the tab on the ladder strap up and slide the clip back.
- 3) Unplug the AC cord.

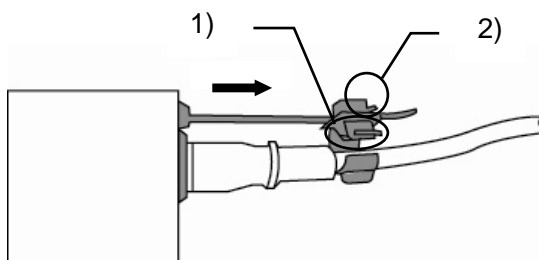

Table of Contents

1. Prior to Starting	9
1-1. Welcome	9
1-2. Features	9
1-3. System Requirements for FA-10DCCRU Setup PC.....	9
2. Main Unit Compatibility	10
2-1. FA-505 Compatibility.....	10
2-2. FA-1010 Compatibility.....	10
2-3. FA-9520 Compatibility.....	10
2-4. FA-9500 Compatibility.....	10
3. Panel Descriptions	11
3-1. Front Panel.....	11
3-2. Rear Panel	13
4. Connecting to Main Units (FA-505/1010/9520/9500)	14
4-1. Basic Configuration	14
4-2. Optional Configuration	15
5. Setup	16
5-1. Connecting an FA-10DCCRU to the Computer.....	16
5-2. Changing the FA-10DCCRU IP Address.....	16
5-3. Web GUI.....	18
5-3-1. Information	18
5-3-2. Network Settings.....	18
5-3-3. User Account Settings	19
5-3-4. Unit ID Assignment	20
5-3-5. Direct Mode Settings.....	21
5-3-6. Event Naming	22
5-3-7. Backup & Restore	23
5-3-8. System Restart	25
6. Controlling FA-505/FA-1010/FA-9520/FA-9500 units.....	26
6-1. Selecting Main Units	26
6-1-1. Connecting a Main Unit in Unit Mode	26
6-1-2. Connecting a Main Unit in Direct Mode	27
6-1-3. Selecting the Connection Mode.....	28
6-2. BYPS/OP (Bypass/Operate)	28
6-3. Selecting an FS Channel	28
6-4. Freeze Setting.....	29
6-5. Split Display	29
6-6. UNITY Settings and Indicators.....	30
6-7. UNITY Button and Unity Mode.....	30
6-8. Process Control (Proc Amp)	31
6-9. Color Correction	32
6-10. Clipping Signal Levels.....	33
6-10-1. YPbPr Clip.....	34
6-10-2. RGB Clip	36
6-11. Verifying Settings	38

6-11-1. When in Color Correction Mode.....	38
6-11-2. When in Clip Mode.....	38
7. Event Memory.....	39
7-1. About Event Memory.....	39
7-2. Data Stored in Events	39
7-3. Data Loaded from Events	39
7-4. Saving Settings to Events	40
7-5. Loading Settings from Events	40
8. SYSTEM Settings.....	41
8-1. System Settings	42
8-2. GPI OUT LED Indicator Brightness Settings	43
9. Information Display.....	44
9-1. Messages during Main Unit Connection	44
9-2. Messages during Bypass Setting.....	45
9-3. Messages during FS Selection	45
9-4. Messages during Event Memory Operation	46
9-5. Messages during Freeze Setting	46
9-6. Messages during Split Setting.....	47
9-7. Messages during Proc Amp Settings.....	47
9-8. Messages during Color Correction Settings	48
9-9. Messages during Video Clip Settings	49
9-10. Messages during System Settings.....	50
10. GPI Interface	51
10-1. FA-GPIO Editor	51
10-1-1. Installing the FA GPIO Editor.....	51
10-2. About the FA GPIO Editor.....	54
10-2-1. Connecting FA GPIO Editor to the FA-10DCCRU.....	54
10-2-2. Loading and Assigning GPI Functions.....	56
10-2-3. GPI Input Settings	57
10-2-4. GPI Output Settings	59
10-2-5. Inverting GPI Output Pulse Polarity	60
10-2-6. Sending GPI Settings.....	60
10-2-7. Pattern Load.....	60
10-2-8. Exporting GPI Settings to Files	61
10-2-9. Importing GPI Settings from Files	61
10-2-10. Verifying GPIO Editor Version	61
10-3. GPI Pattern List.....	62
10-4. GPI1-GPI3 Pin Assignments.....	64
10-5. GPI Input Circuit	65
10-6. GPI Input Control.....	65
10-7. GPI Output Circuit (Same for GPI 1-3)	66
11. FS Link.....	67
11-1. Requirements for FS Link	67
11-2. Notes on FS Link.....	67
11-3. FS Link Examples	67
12. Resetting to Factory Default Settings.....	68

13. Specifications and Dimensions	69
13-1. Unit Specifications.....	69
13-2. External Dimensions	69

1. Prior to Starting

1-1. Welcome

Congratulations! By purchasing an FA-10DCCRUI Remote Control Unit you have entered the world of FOR-A and its many innovative products. Thank you for your patronage and we hope you will turn to FOR-A products again and again to satisfy your video and audio needs.

FOR-A provides a wide range of products, from basic support units to complex system controllers, which have been increasingly joined by products for computer video-based systems. Whatever your needs, talk to your FOR-A representative. We will do our best to be of continuing service to you.

1-2. Features

The FA-10DCCRUI is a dedicated remote control unit for color correction, which can control FA-505, FA-1010, FA-9520 and FA-9500 units.

- Control of up to 100 FA-505 / FA-1010 / FA-9520 / FA-9500 units via Ethernet.
- Coexist with FA-10RU and FA-95RU in a system.
- Direct operation with 14 rotary encoders
- FA-505 / FA-1010 / FA-9520 / FA-9500 can accept up to 5 FA-10DCCRUI control units simultaneously.
- Save up to 100 sets of settings in FA-10DCCRUI
- GPI 30 inputs and 30 outputs
- Expansion control panel: FA-AUX30 (option)
- Windows-based GPIO utility: FA GPIO Editor

1-3. System Requirements for FA-10DCCRUI Setup PC

Item	Recommended
CPU	Intel Core i3, 1.2 GHz or faster
Memory	2 GB or more
OS	Windows 7/8 (32-bit / 64-bit), .NET Framework 4 or higher
Free disk space	1 MB or more
Interface	Ethernet x 1 port
Web browser (*1)	Internet Explorer® 10 Firefox 29 or higher (JavaScript must be enabled.)
Display	1024 x 768 (XGA) or better, 24-bit or 32-bit full-color

2. Main Unit Compatibility

FA-10DCCRU units do not support all FA-505, FA-1010, FA-9520 or FA-9500 versions. Refer to the tables below for compatibility details. Main units with earlier software versions are unable to be (or to be fully) controlled by FA-10DCCRU units.

Upgrade your main unit if it is fully or partially incompatible with the FA-10DCCRU.

2-1. FA-505 Compatibility

FA-10DCCRU has no function restrictions depending on the FA-505 version.

2-2. FA-1010 Compatibility

The table below shows information on FA-1010 / FA-10DCCRU compatibility.

FA-1010 Software Ver. 1.00 - 2.01	Unable to connect with FA-10DCCRU.
FA-1010 Software Ver. 2.22	Able to be controlled, with the following functions unavailable: BY-PASS/OPERATE Y Level SPLIT
FA-1010 Software Ver. 3.00 or higher	Able to be fully controlled by FA-10DCCRU.

Refer to the FA-1010 Operation Manual for details on software version verification.

2-3. FA-9520 Compatibility

The table below shows information on FA-9520 / FA-10DCCRU compatibility.

FA-9520 mode Software Ver. 1.00 - 2.01 FA-9500 mode Software Ver. 7.00 - 8.01	Unable to connect with FA-10DCCRU.
FA-9520 mode Software Ver. 2.02 or higher FA-9500 mode Software Ver. 8.02 or higher	Able to be controlled, with the following functions unavailable: BY-PASS/OPERATE Y Level SPLIT

Refer to the FA-9520 Operation Manual for details on software version verification.

2-4. FA-9500 Compatibility

The table below shows information on FA-9500 / FA-10DCCRU compatibility.

Soft Version 1.00 - 8.00	Unable to connect with FA-10DCCRU.
Soft Version 8.01 or higher	Able to be controlled, with the following functions unavailable: BY-PASS/OPERATE Y Level SPLIT

Refer to the FA-9500 Operation Manual for details on software version verification.

3. Panel Descriptions

3-1. Front Panel

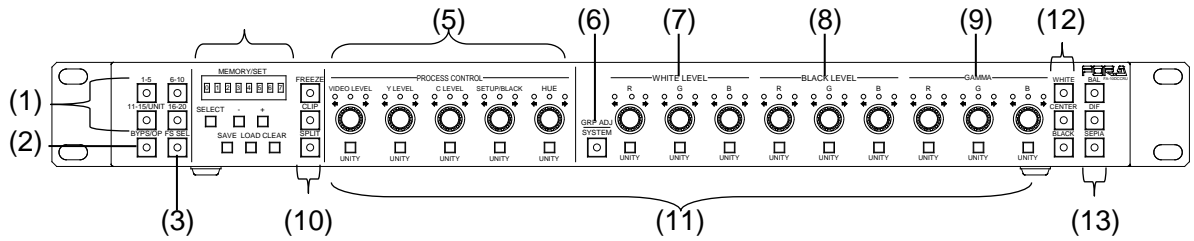

No.	Name	Description
(1)	1-5, 6-10, 11-15/UNIT, 16-20	Main Unit selection buttons. Before selecting Main Unit ID numbers with these buttons, assign Main Units (FA-505, FA-1010, FA-9520 and FA-9500) to Unit ID numbers using IP addresses. See section 5-3-4. "Unit ID Assignment" and section 5-3-5. "Direct Mode Settings" for more details. Two connection modes are available: Direct and Unit . See section 6-1. "Selecting Main Units."
(2)	BYP/OP (BYPASS / OPERATE)	Lit Performs the correction and outputs the corrected signal. (Operate mode)
		Flashing Outputs the input signal without performing color correction (Bypass mode)
(3)	FS SEL	Allows you to select an FS for which to adjust color correction settings when connecting to an FA-505, FA-1010 or FA-9520 (in FA-9520 mode). The button is disabled when connecting to an FA-9520 from FA-9500 or FA-9500 unit. See section 6-3. "Selecting an FS Channel." Holding down the button allows you to select the Connection mode between Direct and Unit. See section 6-1-3. "Selecting the Connection Mode."
(4)	MEMORY/SET	Allows you to save settings to / load settings from memory as needed. See section 7. "How to Use Event Memory." Setting values are displayed while saving or loading settings. See section 9. "Information Display."
(5)	PROCESS CONTROL	Allows you to adjust Proc Amp settings in Color Correction mode (with CLIP (10) unlit). See section 6-8. "Process Control" and section 6-9. "Color Correction." Allows you to clip signal levels in Clip mode (with CLIP (10) lit) using the three center buttons. See section 6-10. "Clipping Signal Levels." The settings apply to the selected FS if controlling an FA-505, FA-1010 or FA-9520 in FA-9520 mode.
(6)	GROUP ADJ SYSTEM	Allows you to adjust R, G, and B component levels (White, Black or Gamma) all together . While the button is lit, R, G and B component levels can be set together by turning the R, G or B control button. When holding down the button, the button blinks and the menu changes to SYSTEM settings mode. See section 8. "System Settings."
(7)	WHITE LEVEL	Allows you to adjust the white level. This setting is disabled in Sepia mode. The level adjustment applies to the selected FS if controlling an FA-505, FA-1010 or FA-9520 in FA-9520 mode.
(8)	BLACK LEVEL	Allows you to adjust the black level. This setting is disabled in Sepia mode. The level adjustment applies to the selected FS if controlling an FA-505, FA-1010 or FA-9520 in FA-9520 mode.

No.	Name	Description
(9)	GAMMA LEVEL	Allows you to adjust the gamma level. In Sepia mode, only Y signal can be adjusted using the G control button. The level adjustment applies to the selected FS if controlling an FA-505, FA-1010 or FA-9520 in FA-9520 mode.
(10)	FREEZE	Allows you to toggle Freeze On or Off. The button turns on while the video is frozen. See section 6-4. "Freeze Setting." The setting applies to the selected FS if controlling an FA-505, FA-1010 or FA-9520 in FA-9520 mode.
	CLIP	Allows you to toggle the mode between Color Correction and Clip . Holding down the buttons simultaneously changes the mode to Clip. See section 6-10. "Clipping Signal Levels." The setting applies to the selected FS if controlling an FA-505, FA-1010 or FA-9520 in FA-9520 mode.
	SPLIT (*1)	Allows you to change the video display mode in the following order: OFF > MODE1 > MODE2 > MODE3. The setting applies to the selected FS (by FS SEL) in an FA-1010.
(11)	UNITY (*2)	Pressing the UNITY button resets the value to default. Pressing the button again returns the default value to the previous value.
(12)	WHITE/ CENTER/ BLACK	Selects a gamma curve from WHITE, CENTER or BLACK. The setting applies to the selected FS if controlling an FA-505, FA-1010 or FA-9520 in FA-9520 mode.
(13)	BAL/DIF/SEPIA	Selects a correction type for Color Correction mode from the following: BAL (Balanced, mainly used for RGB signals) DIF (Differential, mainly used for YPbPr signals) SEPIA (Sepia color) The setting applies to the selected FS if controlling an FA-505, FA-1010 or FA-9520 in FA-9520 mode.

(*1) Split control is available if the FA-1010 software version is 3.00 or higher.

Split control is not available for FA-9520 or FA9500.

(*2) Two operation modes, **Linked Unity** and **Unlinked Unity**, are available for setting WHITE LEVEL, BLACK LEVEL and GAMMA LEVEL using the R, G and B UNITY buttons. See section 8. "SYSTEM Settings" and Section 6-7. "UNITY Button and Unity Mode" for more details.

3-2. Rear Panel

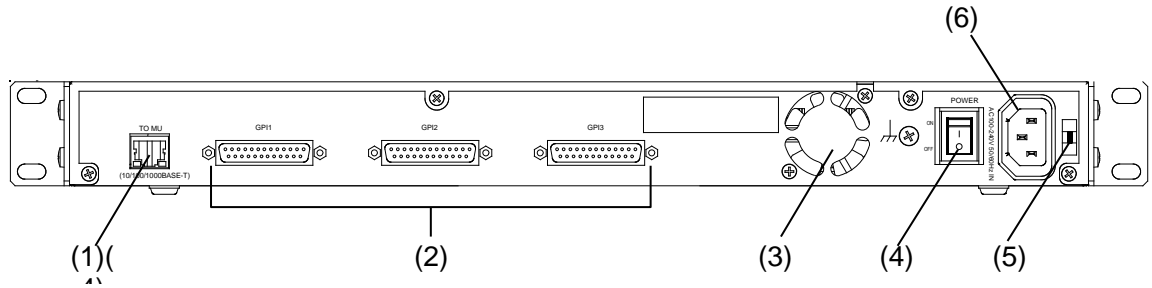

No.	Name	Description
(1)	TO MU	Used to connect to an FA-505, FA-1010, FA-9520 or FA-9500 via LAN. Set the unique IP address and connect to the network.
(2)	GPI1 to GPI3	Used to connect an FA-AUX30 or external expansion switch panel(s). To assign GPI functions, install the FA GPIO Editor software using the supplied CD-ROM. See section 10. "GPI Interface" for details on GPI connectors.
(3)	Cooling Fan	Used to air cool the unit to prevent overheating. Do not block the ventilation openings.
(4)	Ground Terminal	Used to ground the unit to protect operators against static electricity and / or electrical shock.
(5)	AC cord retaining clip anchor hole	Used to anchor the AC cord retaining clip.
(6)	AC IN	Used for connection to an AC power source via the supplied accessory cord. (AC 100V-240V 50/60Hz)

4. Connecting to Main Units (FA-505/1010/9520/9500)

Connect FA-10DCCRU units to main units (FA-505, FA-1010, FA-9520 and FA-9500) via Ethernet. FA-10RU and FA-95RU units can be connected in the same network.

4-1. Basic Configuration

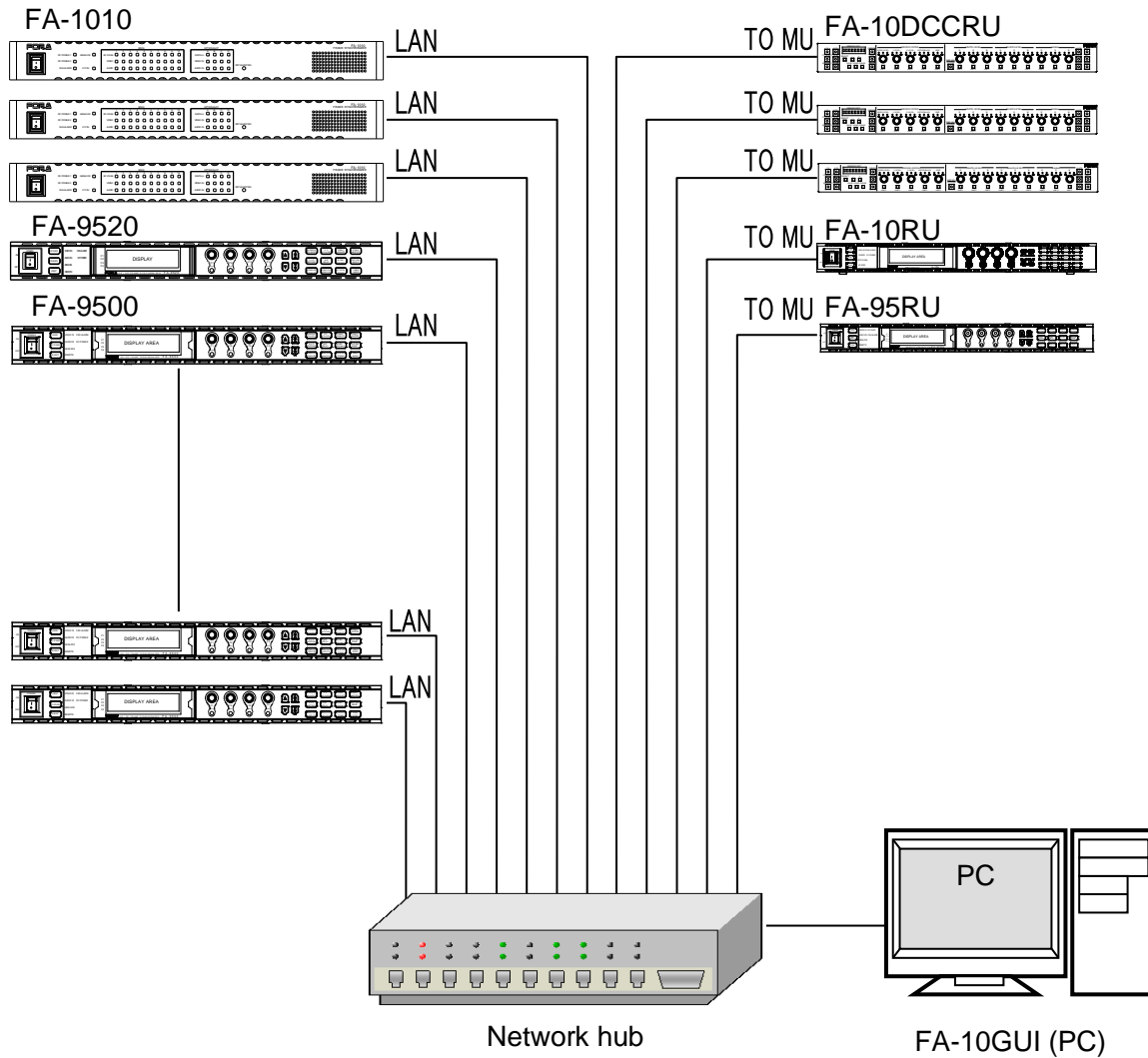

Specify unique IP addresses for all devices connected to the network.
See section 5-3-2. "Network Settings" for details on IP address settings.
A single FA-505, FA-1010, FA-9520 or FA-9500 unit can be controlled by up to 5 remote FA-10DCCRU, FA-10RU and/or FA-95RU units.
An attempted 6th connection will not be accepted.

4-2. Optional Configuration

◆ Connection with an FA-AUX30 option

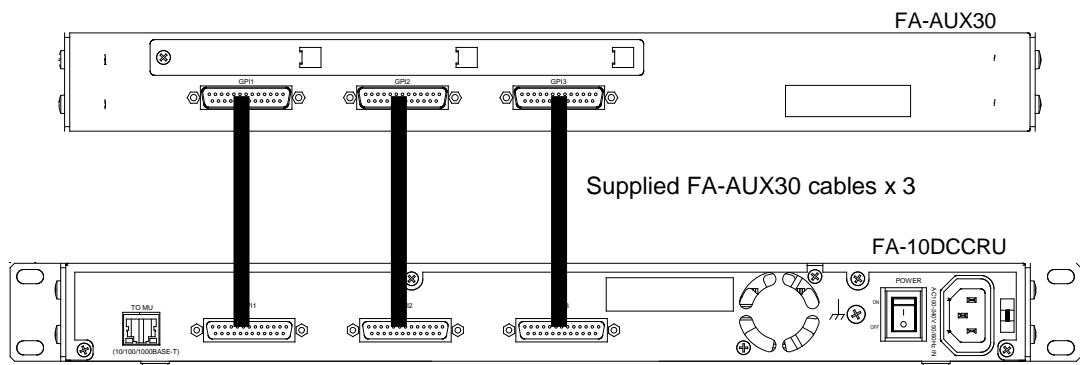

◆ Connection with a user-made switch box

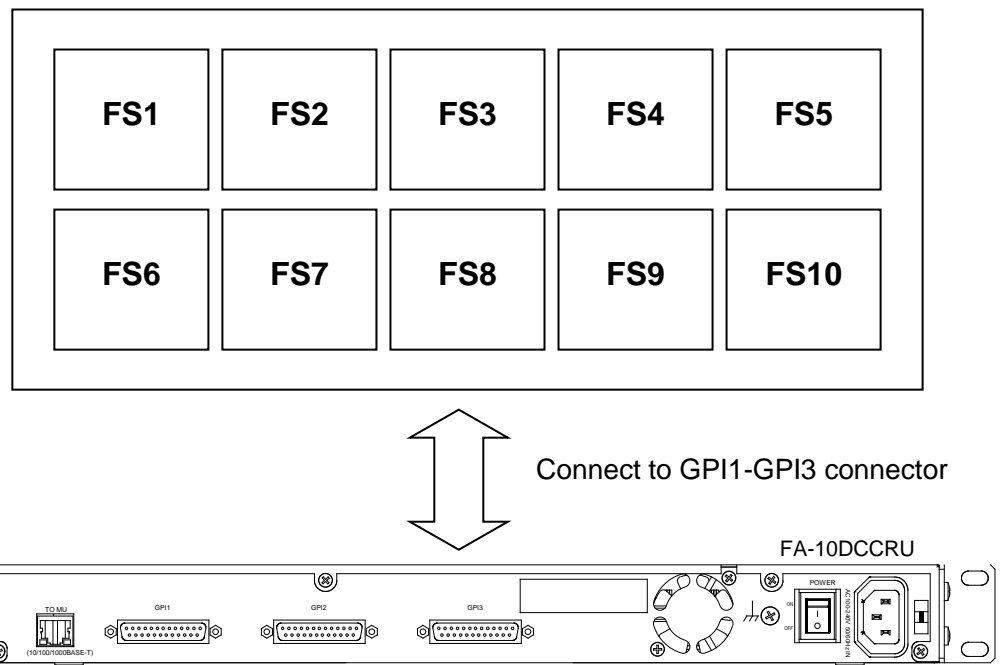

* See section 10. "GPI Interface" for details on GPI connectors.

5. Setup

5-1. Connecting an FA-10DCCRU to the Computer

- (1) Connect the FA-10DCCRU and your PC. Set the IP address of the PC so that it appears on the same LAN subnet. For example, 192.168.0.1 as shown below.

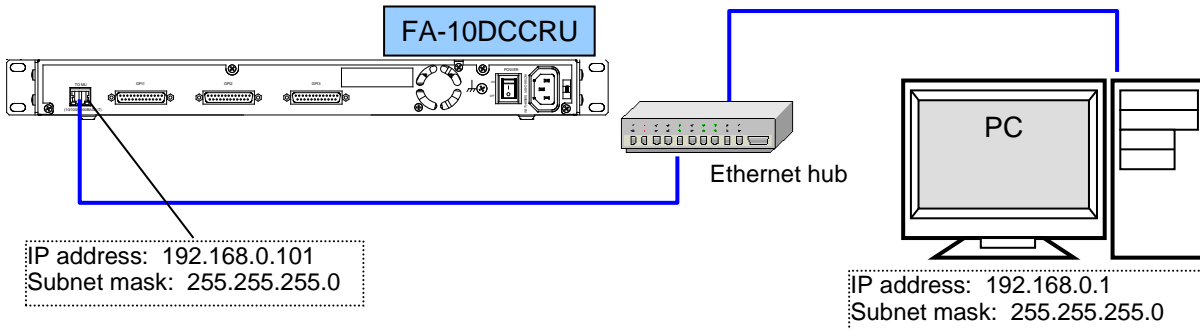

- (2) Launch your web browser on the PC. Microsoft Internet Explorer is used in this manual. Other web browsers are also supported.
- (3) Enter the IP address of the FA-10DCCRU (default: **192.168.0.101**) in your browser's address bar.
- (4) When the FA-10DCCRU connection is established, the **Information** page will appear.

5-2. Changing the FA-10DCCRU IP Address

- (1) In the left pane of the Web GUI, click **Network Settings**.

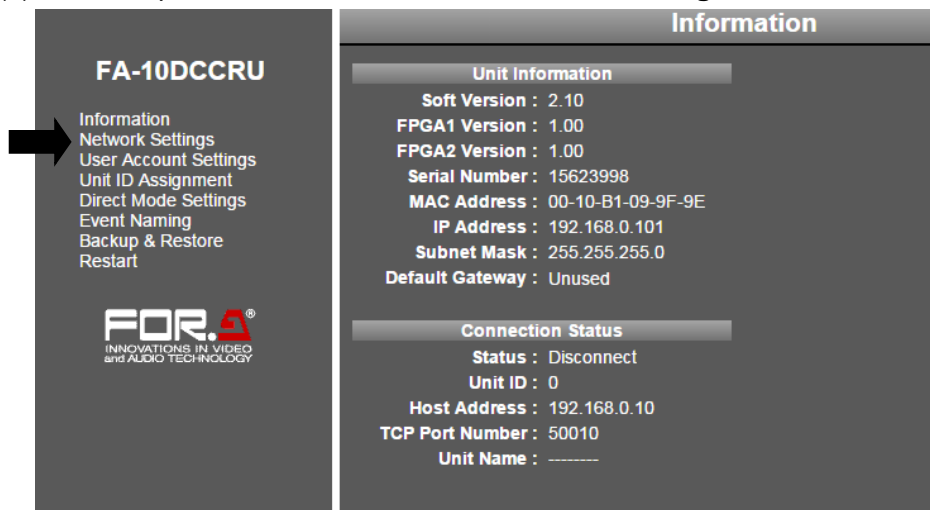

- (2) If a login dialog window as shown below appears, enter the following user name and password.

Default User name and Password
User name: **fa10dccru**
Password: **foranetwork**



- (3) The Network Settings page is displayed in the right pane.
- (4) Change the FA-10DCCRUIP address as needed. Set a unique IP address and subnet mask in the LAN.
- (5) Click **Apply**.

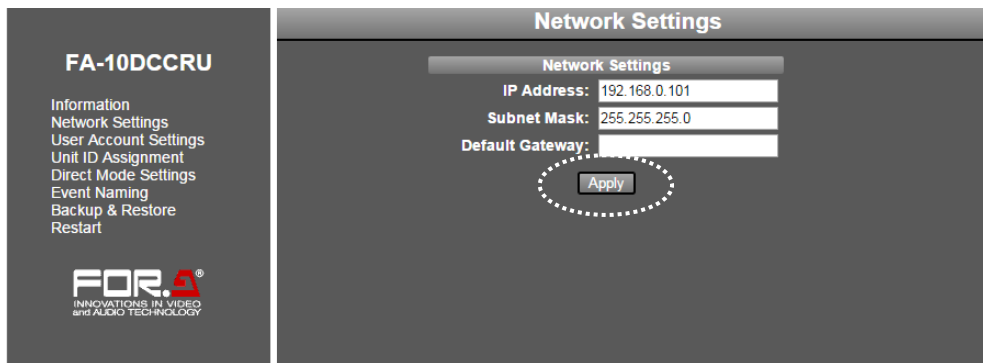

- (6) Wait at least 1 second then click **Restart** in the left pane to display the System Restart page. Click **Restart** in the right pane to restart the FA-10DCCRUI. New network settings are applied after the restart.

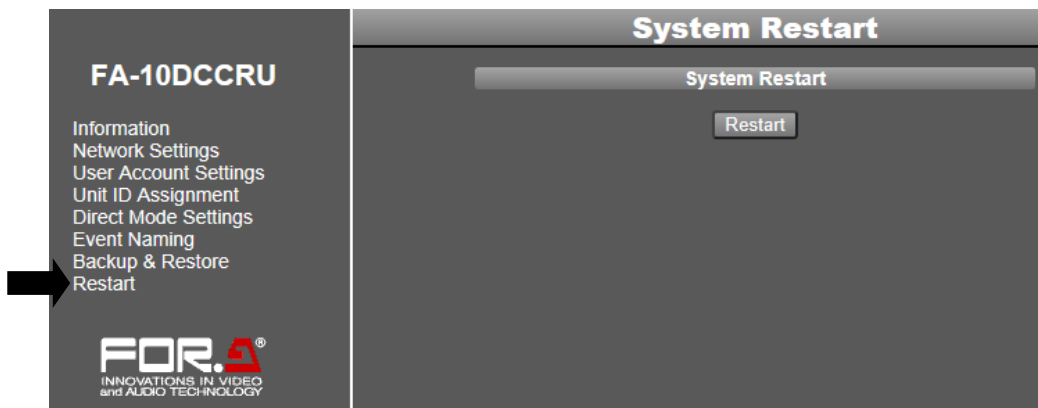

5-3. Web GUI

5-3-1. Information

Click **Information** in the left pane to display the Information page, in which Unit Information and Connection Status details of the FA-10DCCRU are displayed.

- FA-10DCCRU version, serial number and network setting details
- Main Unit information

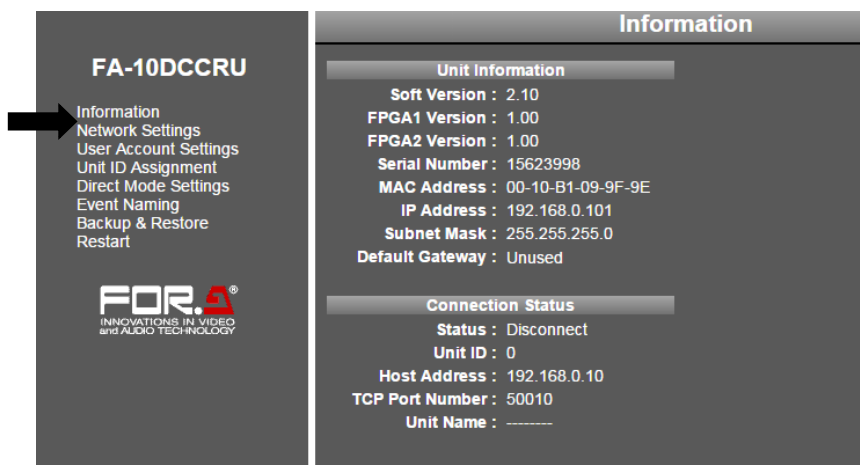

Click **Refresh** to refresh the page.

5-3-2. Network Settings

In the left pane of the Web GUI, clicking **Network Settings** displays the Network Settings page in the right pane, in which FA-10DCCRU network settings are entered. After settings are complete, click **Apply** to apply them.

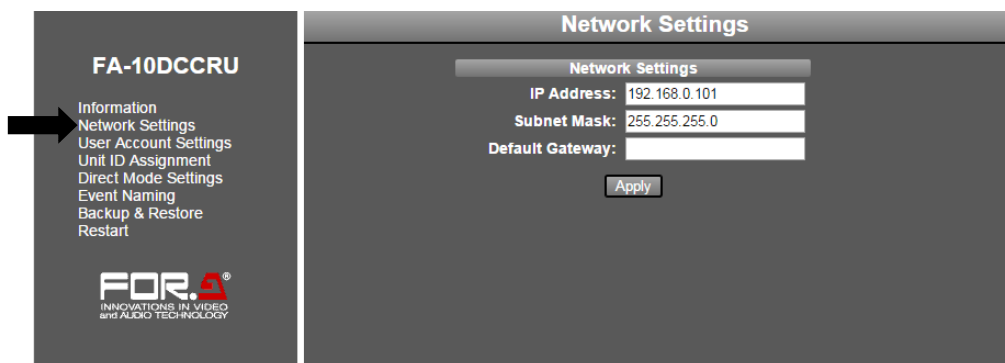

Item	Default	Description
IP Address	192.168.0.101	Allows you to set the FA-10DCCRU IP address and subnet mask. Set a unique IP address and connect to a LAN network.
Subnet Mask	255.255.255.0	
Default Gateway		This setting is not required. Set the Default Gateway address according to your network circumstances.

IMPORTANT

Network Settings are applied after the FA-10DCCRU restarts. See section 5-3-8. "System Restart."

5-3-3. User Account Settings

This page allows you to change user name and password settings by logging in through the Web GUI.

The screenshot shows the 'User Account Settings' page for the FA-10DCCRU. On the left, a navigation menu lists several options, with 'User Account Settings' selected and marked with a circled '1'. The main content area has a header 'User Account Settings' and a sub-header 'User Account Settings'. It features three input fields: 'User Name' with the value 'fa10dccru' and a '(15 Max char)' limit, 'Password' with masked characters and a '(15 Max char)' limit, and 'Confirm Password' with a '(15 Max char)' limit. A '3 Apply' button is positioned below the password fields. In the left sidebar, a '4 Restart' button is visible. The FOR.A logo is located at the bottom left of the sidebar.

- (1) Click **User Account Settings** in the left pane.
- (2) Enter a user name (Alphanumeric, up to 15 characters).
Enter a password (Alphanumeric, up to 15 characters).
Re-enter the password.
- (3) Click **Apply**.
- (4) Wait at least 1 second, then click **Restart** in the left pane to display the System Restart page. Click **Restart** in the right pane to restart the FA-10DCCRU. The new network settings are applied after the restart.

IMPORTANT

User Account Settings are applied after the FA-10DCCRU restarts. See section 5-3-8. "System Restart."

Do **not** forget your user name or password.

If you forget your user name or password, set the FA-10DCCRU back to factory default settings (see section 12. "Resetting to Factory Default Settings") and reset your user name and password.

5-3-4. Unit ID Assignment

Click **Unit ID Assignment** in the left pane to display the Unit ID Assignment page. This page allows you to assign Main Units to **Unit ID** numbers using IP addresses and unit names. When controlling multiple main units, unit names can help you identify units. Up to 100 units can be registered in the list.

The screenshot shows the 'Unit ID Assignment' interface for the FA-10DCCRU device. On the left is a sidebar with a menu including 'Information', 'Network Settings', 'User Account Settings', 'Unit ID Assignment', 'Direct Mode Settings', 'Event Naming', 'Backup & Restore', and 'Restart'. The main area is titled 'Unit ID Assignment' and shows a selection of 'Unit 1 - 20 / Unit 21 - 40 / Unit 41 - 60 / Unit 61 - 80 / Unit 81 - 100'. Below this is a table for 'Unit 1 - 20' with columns for 'IP Address', 'Port', and 'Unit Name'. The first row is populated with '192.168.0.10' and '50010'. A table with 10 rows and 3 columns is shown below. At the bottom right is an 'Apply' button. Numbered callouts 1-4 indicate key actions: 1. Clicking the Unit ID number (Unit 1-20), 2. Entering an IP address, 3. Entering a Unit Name, and 4. Clicking the Apply button.

ID No.:	Unit 1 - 20					
	IP Address	Port	Unit Name	IP Address	Port	Unit Name
1	192.168.0.10	50010	UNIT NAME			
2						
3						
4						
5						
6						
7						
8						
9						
10						

- (1) Move the mouse over the desired Unit ID numbers at the top of the page to display the list. Then click on the ID numbers (**Unit 1 - 20** for example).
- (2) Enter an IP address (required) under the Unit ID number for each unit (FA-505, FA-1010, FA-9520 or FA-9500) as shown above.

If a unit is not registered in the list, the message “No Assigned IP Address” will appear when trying to connect to the unit.

- (3) Enter a unit name (not required) under the Unit ID number. Units names must be alphanumeric and within 15 characters.

Unit names are displayed on the FA-10DCCRU front panel while selecting a main unit or after connection is established. If a unit name is not specified, the IP address will be displayed instead of a unit name.

Change the Port (TCP port number) setting only when another device than those below exists in the LAN and uses this port number:

FA-505 / FA-50GUI / FA-1010 / FA-10GUI /
FA-9520 / FA-9500 / FA-10RU / FA-95RU /
FA-10DCCRU

If a port number is changed, set the same number for all devices listed above.

- (4) After all settings are finished, click **Apply**.

IMPORTANT
Do not forget to click Apply . When the list display or menu page is changed without clicking Apply , the settings in the list are ignored and they will return to their previous settings.

5-3-5. Direct Mode Settings

Click **Direct Mode Settings** in the left pane to display the Direct Mode Settings page. This page allows you to assign Main Units to **MU1** to **MU20**, which are used for direct mode connections.

Up to 20 MU units (MU 1 – MU 20) can be registered in the Direct Mode list, but they must be registered in the Unit ID list. (See the previous page).

See section 6-1-2. “Connecting a Main Unit in Direct Mode” for details on the connection procedure.

As factory default, **Unit ID 1 to 20** are set to **MU 1 to 20**. If you need to change these assignments, follow the procedure below.

The screenshot shows the 'Direct Mode Settings' interface for the FA-10DCCRU device. On the left, a navigation menu includes: Information, Network Settings, User Account Settings, Unit ID Assignment, Direct Mode Settings (highlighted with a black arrow), Event Naming, Backup & Restore, and Restart. The main content area is titled 'Direct Mode Settings' and contains four tables for configuring MU 1-5, MU 6-10, MU 11-15, and MU 16-20. Each table has columns for 'MU' and 'Unit ID' with corresponding input fields. An 'Apply' button with a circled '3' is located at the bottom right of the main area.

MU 1 - 5		MU 6 - 10	
MU	Unit ID	MU	Unit ID
1:	<input type="text" value="1"/>	6:	<input type="text" value="6"/>
2:	<input type="text" value="2"/>	7:	<input type="text" value="7"/>
3:	<input type="text" value="3"/>	8:	<input type="text" value="8"/>
4:	<input type="text" value="4"/>	9:	<input type="text" value="9"/>
5:	<input type="text" value="5"/>	10:	<input type="text" value="10"/>

MU 11 - 15		MU 16 - 20	
MU	Unit ID	MU	Unit ID
11:	<input type="text" value="11"/>	16:	<input type="text" value="16"/>
12:	<input type="text" value="12"/>	17:	<input type="text" value="17"/>
13:	<input type="text" value="13"/>	18:	<input type="text" value="18"/>
14:	<input type="text" value="14"/>	19:	<input type="text" value="19"/>
15:	<input type="text" value="15"/>	20:	<input type="text" value="20"/>

- (1) Change the Unit ID numbers for MU 1 to MU 5. Click the **MU 1–5** button.
- (2) Change the Unit ID numbers for MU 6 to MU 10, then click the **MU 2-10** button. Change other settings in the same way.
- (3) When all settings are finished, click **Apply**.
Note that if another page is entered without clicking **Apply**, the settings are ignored.

IMPORTANT
Note that if an IP address is not set under the associated Unit ID number in the Unit Assignment page (see section 5-3-4), it cannot be accessed using the Unit ID or MU number.
When connecting to main units using the <u>1-5</u> , <u>6-10</u> , <u>11-15</u> or <u>16-20</u> button in Direct mode, user names set in the Unit Assignment page are displayed. If user names are not set, IP addresses are displayed.
Setting Unit ID to “0” in the Direct Mode Settings page disables the connection. Use “0,” as necessary.

5-3-6. Event Naming

Click **Event Naming** in the left pane to display the Event Naming page. This page allows you to assign names to events. The default names are **Event 1 to Event 100**.

To change event names, follow the procedure below.

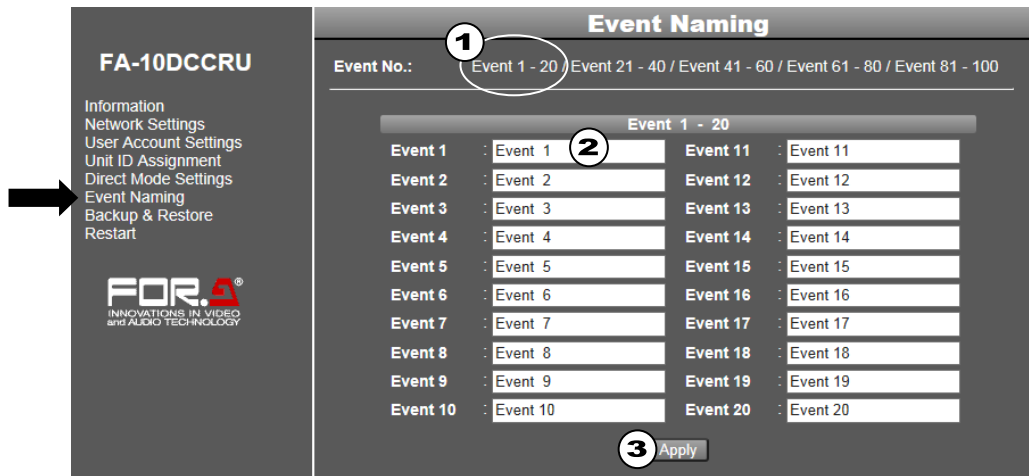

- (1) Move the mouse over the desired event numbers at the top of the page to display the list. Then click on the event numbers (**Event 1- 20** for example).
- (2) Type a new name (alphanumeric, within 15 characters) under each event.
- (3) Click **Apply**.

IMPORTANT

Do **not** forget to click **Apply**. When the list display or menu page is changed without clicking **Apply**, the settings in the list are ignored and the event names return to their previous settings.

5-3-7. Backup & Restore

Click **Backup & Restore** in the left pane to display the Backup & Restore page. This page allows you to perform the following backup and restoration tasks.

- Backup and restore **Network Settings, Unit ID Assignment, Direct Mode Settings,** and **Event Name** pages, and **GPI** and **System** settings.
- Backup and restore **Event** data (See sections 7-4 and 7-5.)
- Copy settings to another FA-10DCCRU unit. (See sections 7-2 and 7-3.)

◆ Backing Up All FA-10DCCRU Settings (excluding Event Data)

Clicking **Save** in the Config Data area allows you to save all settings as shown below.

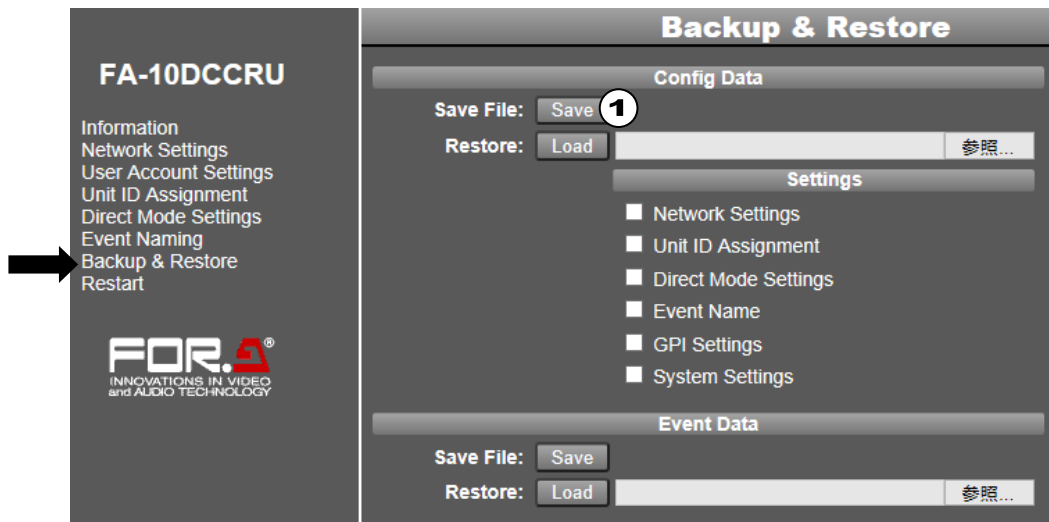

(1) Click **Save** in the Config Data area to display the Download dialog.

(2) Click **Save** in the dialog.

(3) A Select Destination dialog will appear. Specify the destination folder and click **Save**.

The FA-10DCCRU settings are automatically stored in the backup file named "fa10dccru.csv." Change the file name as necessary.

◆ Restoring Settings

To restore stored settings, proceed as follows.

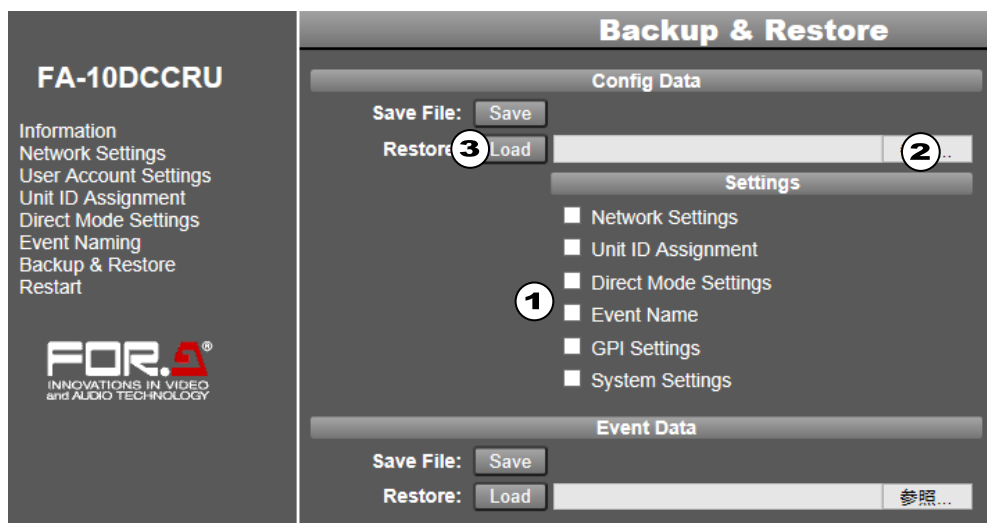

- (1) Check on the checkboxes in the Config Data area to select data.
- (2) Click **Browse** to select the backup file.
- (3) Click **Load**. A confirmation dialog will appear. Click **OK** to load the settings.
To cancel the process, click **Cancel**.

IMPORTANT

After loading network settings, restart the FA-10DCCRUI. (See section 5-3-8. "System Restart.")

◆ **Saving Event Data**

This procedure allows you to save all event data (1 – 100) in a file.

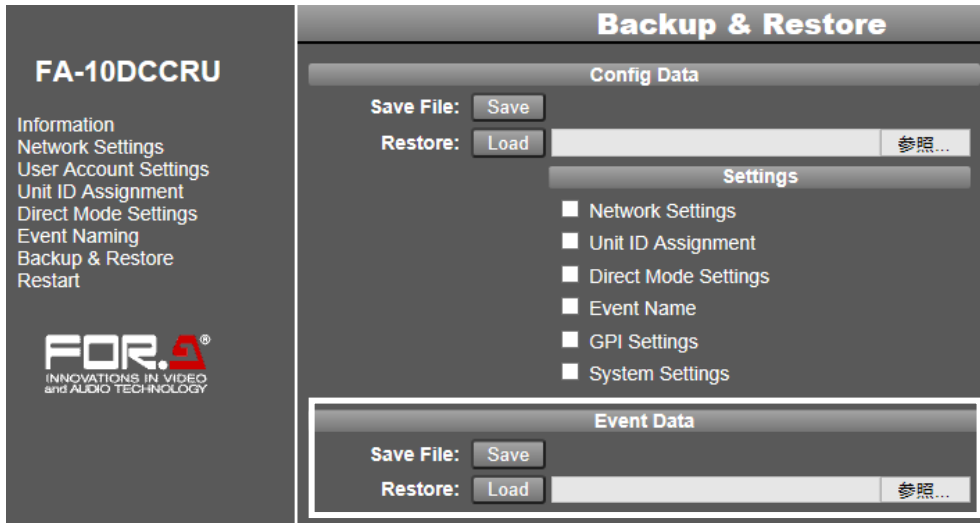

- (1) Click **Save** in the Config Data area to display the Download dialog.
- (2) Click **Save** in the dialog.
- (3) Specify the destination folder and click **Save**. All event data are automatically stored in the file named **fa10dccru_evt.1re**. Change the file name as necessary.

◆ **Restoring Event Data**

- (1) Click the browse button in the Event Data area and select the event backup file.
- (2) Click **Load**. All event data stored in the file are loaded.

IMPORTANT

Note that once event data are loaded, all settings in the FA-10DCCRUI are replaced.

5-3-8. System Restart

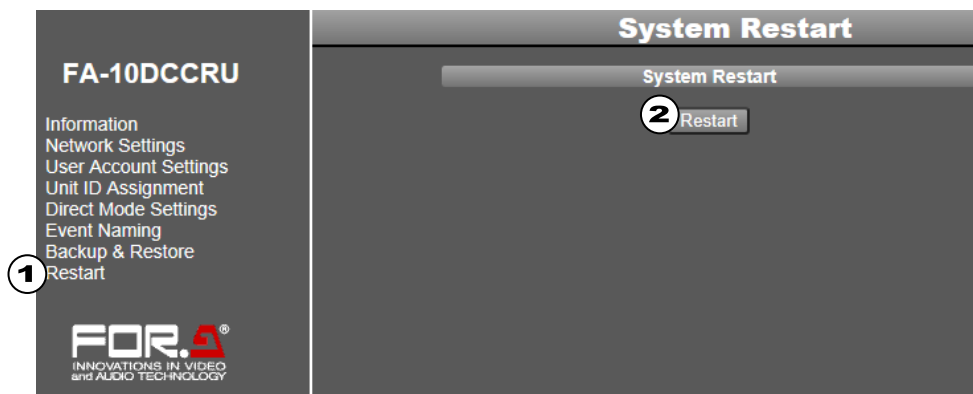

- (1) Click **Restart** in the left pane to display the System Restart page.
- (2) Click **Restart** in the right pane.
- (3) A confirmation dialog will appear. Click **OK** to restart the FA-10DCCRU.

Note that the following settings require a system restart and that they are applied after the restart. Do not forget to restart the FA-10DCCRU.

- Network Settings (See section 5-3-2. “Network Settings.”)
- User name or password settings (See section 5-3-3. “User Account Settings.”)
- Network Settings from the Backup & Restore page (See section 5-3-6. “Backup & Restore.”)

6. Controlling FA-505/FA-1010/FA-9520/FA-9500 units

6-1. Selecting Main Units

When connecting Main Units (FA-505, FA-1010, FA-9520 and FA-9500) from an FA-10DCCRUC, the following two connection modes are available:

- **Unit mode:** Connects to Main Units using Unit ID numbers.
- **Direct mode:** Connects to Main Units using Direct Numbers (**MU1** to **MU20**)
(Default connection mode is Direct mode.)

IMPORTANT

When powered on, wait at least 1 second and a half before the connection is established.

6-1-1. Connecting a Main Unit in Unit Mode

- (1) Set connection mode to **Unit**. (See section 6-1-3. "Selecting the Connection Mode.")
- (2) Press **[11-15/UNIT]**.
- (3) Turn **[VIDEO LEVEL]** to select a Unit ID. (**[+]** and **[-]** buttons also available. Pressing and holding these buttons scrolls selections.)
The Unit ID number is displayed while a selection is being entered.
About 2 seconds later when the selection is confirmed, the Unit Name or IP address will also be displayed in a scroll view.

<Display examples>

ID01: FA-1010	When IP Address and User Name are set under Unit ID 01:
ID01: 192.168.0.10 (No Name)	When only IP Address is set under the Unit ID number:
ID01: No Assigned IP Address	When nothing is set under Unit ID 01: FA-10DCCRUC cannot connect to a unit using Unit ID 01. Set an IP address and User Name for this number. See section 5-3-4. "Unit ID Assignment."

If **Disconnect** is selected instead of a Unit ID number, this connection channel is disabled.

- (4) Press **[SELECT]** or **[11-15/UNIT]** to start the connection. While connecting to a main unit, "Connecting(Unit)" is displayed. If the connection time is too short, the message may not appear.

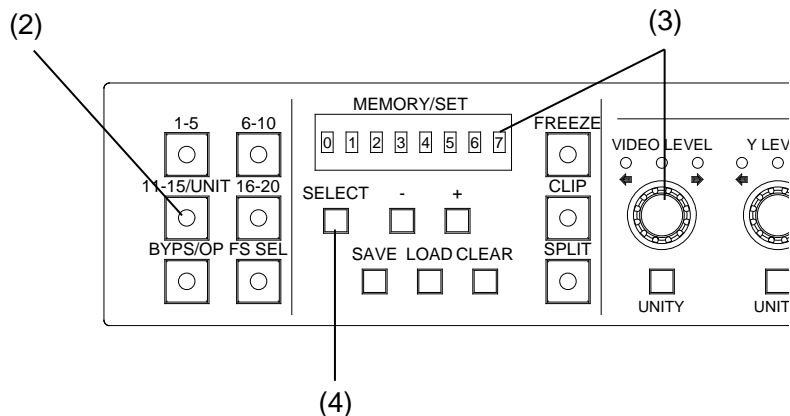

To cancel the connection process, press **[CLEAR]**.

<Display Examples (after connection)>

Connected: FA-1010	When IP Address and User Name (FA-1010) are set under the Unit ID number :
Connected: IP 192.168.0.10	When only IP Address (192.168.0.10) is set under the Unit ID number:

6-1-2. Connecting a Main Unit in Direct Mode

- (1) Set the connection mode to **Direct**. (See section 6-1-3. "Selecting the Connection Mode.")
- (2) Press a number button within the desired Unit ID sequence: **1-5**, **6-10**, **11/15/UNIT** or **16-20**. Scrolling through a sequence, press the associated button as many times as needed; for example, to connect to an FA-1010 with Direct ID 1, press **1-5** once, to connect to an FA-1010 with Direct ID 7, press **6-10** twice. (See "Selecting an MU ID" below.)

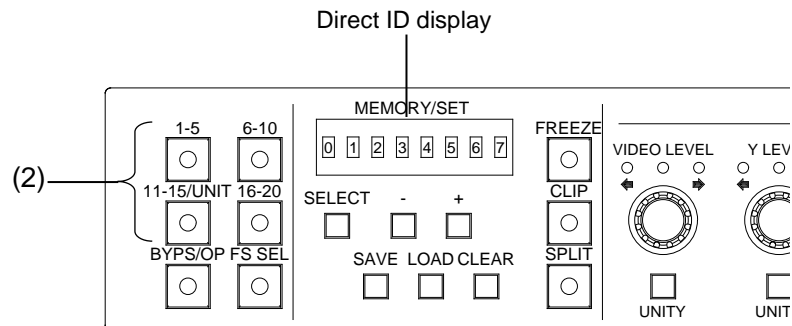

- (3) While connecting to a main unit, "Connecting(Direct)" is displayed. If the connection time is too short, the message may not appear.

To cancel the connection process, press **CLEAR**. The message "Please Choose Direct MU No" will then be displayed, and the number buttons will blink, allowing you to reselect a Direct ID number.

<Display Examples (after connection)>

Connected: FA-1010	When User Name is set for the connected main unit:
Connected: IP 192.168.0.10(No Name)	When User Name is not set for the connected main unit:
Disconnect	No main unit is connected:

* See section 5-3-4. "Unit ID Assignment" for details on Unit Name settings.

◆ Selecting an MU ID

To select a desired MU ID, press the button until the desired ID number is displayed. Every time each number button is pressed, the displayed number will scroll through in the following order.

1-5 button:	MU 1→2→...→5→1
6-10 button:	MU 6→7→...→10→6
11-15 button:	MU 11→12→...→15→11
16-20 button:	MU 16→17→...→20→16

If an IP address is not registered for an MU ID number, the number will be skipped. See section 5-3-5. "Direct Mode Setting" for details on MU ID number settings. See section 5-3-4. "Unit ID Assignment" for details on main unit assignments.

6-1-3. Selecting the Connection Mode

- (1) Press and hold down the **FS SEL** button for about 3 seconds.
- (2) The current connection mode is displayed in a scroll view.
- (3) To change to "Direct Mode Connection," press **-**.
To change to "Unit Mode Connection," press **+**.
- (4) Verify the selection on the display and press **SELECT** or **FS SEL** to confirm the selection.

IMPORTANT

If the connection mode is changed from **Unit** to **Direct**, the message "Please Choose Direct MU No" will appear and the number buttons will blink. Select a Direct ID number to connect to a main unit.

6-2. BYPS/OP (Bypass/Operate)

Pressing the **BYPS/OP** button changes the Bypass/Operation mode:

- Bypass mode: The button is flashing and FA-505 / FA-1010 Color Correction is bypassed.
- Operate mode: The button is lit.

This mode cannot be changed while adjusting Clip levels. (See section 6-10. "Clipping Signal Levels.")

- * Bypass can be selected when the FA-1010 software version is 3.00 or higher.
- Bypass cannot be selected for the FA-9520 or FA-9500.

6-3. Selecting an FS Channel

When connecting FA-505 units, an FS channel can be selected from FS1 to FS5.

When connecting FA-1010 units, an FS channel can be selected from FS1 to FS10.

When connecting an FA-9520 in FA-9520 mode, an FS can be selected between FS1 and FS2.

When connecting an FA-9520 in FA-9500 mode, an FS cannot be selected.

- (1) Press **FS SEL** to turn on the button. The selected FS number is displayed.
- (2) Use **-** and **+** to change the FS for control.

When connecting FA-505/FA-1010 units and FS names are registered, the selected FS is displayed by its name. (FS names are not displayed for FA-9520 units in FA-9520 mode.)

Pressing and holding the **-** or **+** button scrolls selections.

While selecting an FS, the name is displayed in short form such as "FS1."

About 2 seconds after a selection, the name will appear in long form such as "FA-1010 FS1."

- * See "FA-1010 Operation Manual" for details on setting FS Names.
- * See "FA-505 Operation Manual" for details on setting FS Names.

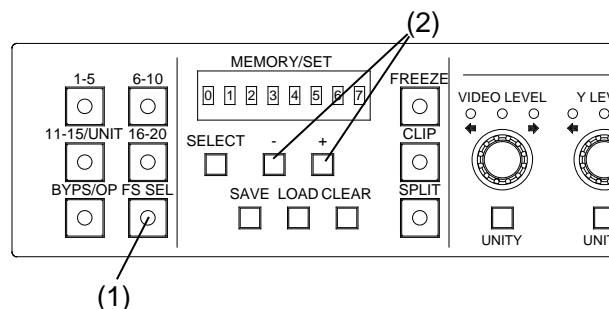

NOTE

While controlling an FS (**FS SEL** lit), other settings than the FS selection are not displayed. To display other settings, press **FS SEL** to turn the button light off.

6-4. Freeze Setting

The Freeze setting is available only when **Sync Mode** is set to **Frame** in the main FA-505, FA-1010, FA-9520 or FA-9500 unit. (See the respective Operation Manuals for details on Sync Mode.)

Pressing the **FREEZE** button turns Freeze On (button lit) or Off (button unlit)

The "Freeze" function is applied to FS channels for FA-505, FA-1010 and FA-9520 (FA-9520 mode) units.

The "Freeze" function is applied to main units for FA-9520 (FA-9500 mode) and FA-9500 units.

NOTE
Freeze is unable to be set while a main unit is being selected or when changing system settings.
The Freeze setting do not appear when FS SEL is lit.

6-5. Split Display

The mode switches every time the **SPLIT** button is pressed, in the following order:
OFF > MODE1 > MODE2 > MODE3

OFF: Displays the image after correction.

MODE1: Splits the screen vertically and displays images before and after correction.

MODE2: Splits the screen horizontally and displays images before and after correction.

MODE3: Displays the image before correction.

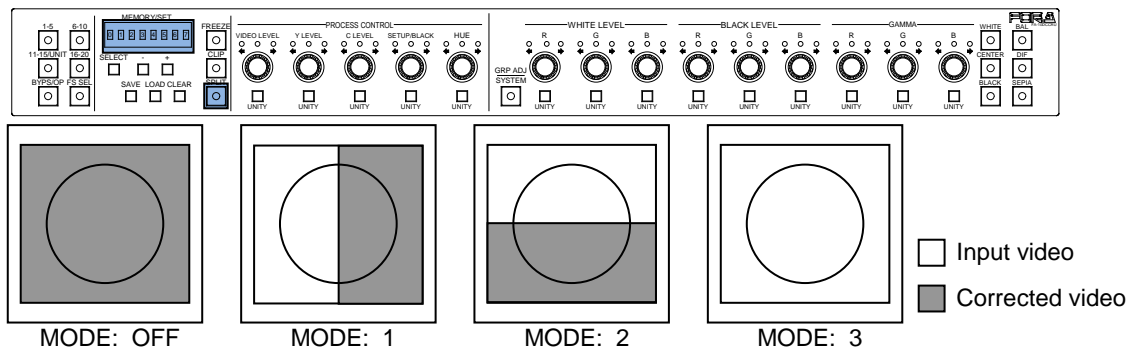

- * Split can be selected when the FA-1010 software version is 3.00 or higher. Split is unable to be set for FA-9520 or FA-9500.

NOTE
Split is unable to be set while in Bypass mode or when changing system settings.
The Split setting do not appear when FS SEL is lit.

6-6. UNITY Settings and Indicators

- Three indicators on each level control button indicate level status as shown below
 - A center indicator that is turned on indicates the level is set to UNITY.
 - A left indicator that is turned on indicates the level is set to less than UNITY level.
 - A right indicator that is turned on indicates the level is set to more than UNITY level.
- Pressing a UNITY button resets the associated value to default. Pressing the button again returns the default value to the previous value.
- An error alarm will sound when a higher or lower limit is exceeded.

6-7. UNITY Button and Unity Mode

UNITY buttons have two operation modes: **Unlinked Unity** and **Linked Unity**.

- Unlinked Unity mode
UNITY is applied only to the **selected** FS.
- Linked Unity mode
UNITY is applied to all linked FS channels (FS Link On).
 - * See section 8. "SYSTEM Settings" for more details on setting UNITY mode.
 - * See section 11. "FS Link" for more details on FS Linking.

6-8. Process Control (Proc Amp)

In this section, use the following parameters to perform Proc Amp adjustments.

VIDEO LEVEL	Adjusts the video level.
Y LEVEL	Adjusts the luminance level. * Y LEVEL can be adjusted when the FA-1010 software version is 3.00 or higher. Y LEVEL is unable to be adjusted for FA-9520 or FA-9500.
C LEVEL	Adjusts the CHROMA LEVEL. (Adjusts the sepia level in Sepia Mode.)
SETUP/BLACK	Adjusts the SETUP/BLACK level.
HUE	Adjusts the HUE. (Adjusts the SEPIA color in Sepia Mode.)

IMPORTANT

Proc Amp is disabled while in Bypass, MU Selection, Clip Setting or System Setting mode.

Proc Amp settings do not appear when **FS SEL** is lit.

Note that changes are applied to all linked FS channels (FS Link On) in FA-505, FA-1010 or FA-9520 (FA-9520 mode). See section 11. "FS Link" for more details.

6-9. Color Correction

In order to enter the Color Correction settings, first you need to select a correction mode using the following three buttons:

BAL (Balance) button: RGB mode
 DIF (Differential) button: Color Difference (YPbPr) mode
 SEPIA button: Sepia mode

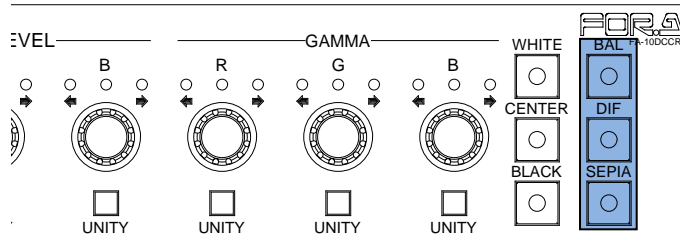

The following settings are available in Color Correction mode.

WHITE LEVEL	White Level setting using the R, G and B components. (Disabled in Sepia mode.)
BLACK LEVEL	Black Level setting using the R, G and B components. (Disabled in Sepia mode.)
GAMMA	Gamma Level setting using the R, G and B components. (Only Y signal is adjustable using G in Sepia mode.) Three gamma curves (White, Center and Black) are selectable.

GROUP ADJ allows you to select between **Group adjustment** and **Individual adjustment**.
 When **GROUP ADJ** is turned **off**, R, G and B levels can be set individually.
 When **GROUP ADJ** is turned **on**, R, G and B levels can all be set together by changing R, G or B.

IMPORTANT
Color Correction is disabled while in Bypass, MU Selection, Clip Setting or System Setting mode.
Color Correction settings are not displayed when FS SEL is lit.
Note that changes are applied to all linked FS channels (FS Link On) in FA-505, FA-1010 or FA-9520 (FA-9520 mode). See section 11. "FS Link" for more details.

6-10. Clipping Signal Levels

To enter clip settings, first, change the mode from Color Correction to Clip.

In the following situations, Clip mode is unable to be selected:

- ◆ **While in System Settings (**GRP ADJ/SYSTEM** is flashing)**
To enter Clip mode, press **GRP ADJ/SYSTEM** to exit the System setting mode.
- ◆ **While Changing Connection Mode (**FS SEL** is flashing)**
To enter Clip mode, press **SELECT** or **FS SEL** to complete the change, or complete the connection process.
- ◆ **While Selecting a Unit ID (**11-15 UNIT** is flashing)**
To enter Clip mode, complete the connection process.
- ◆ **While in Bypass mode (**BYP/OP** is flashing)**
To enter Clip mode, change the mode to **Operate**.

IMPORTANT
Clip settings are not displayed when FS SEL is lit.
Note that changes are applied to all linked FS channels (FS Link On) in FA-505, FA-1010 or FA-9520 (FA-9520 mode). See section 11. "FS Link" for more details.
See section 11. "FS Link" for more details.
If Color Corrector is remotely set to Bypass by another remote unit (FA-10DCCRU or FA-10RU) or FA-10GUI, the system automatically exits CLIP mode.

- (1) Press **CLIP** for at least 3 seconds.
- (2) A beep will sound and the **CLIP** button will flash to indicate the mode has changed to Clip.

Press and hold CLIP.

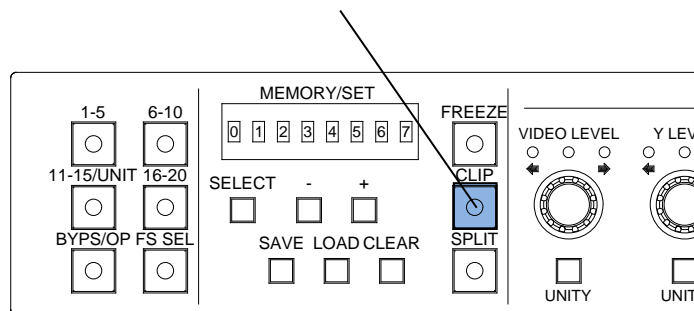

- (3) After all clip settings are finished, press **CLIP** to return to the Color Correction mode.

* To enter clip settings in another FS when connecting to an FA-505, FA-1010 or FA-9520 (FA-9520 mode) unit, press **FS SEL** to turn on the button light, then select an FS. Note that clip settings are applied to the selected FS while **FS SEL** is unlit.

6-10-1. YPbPr Clip

(1) With **CLIP** flashing, press **DIF** on the right end of the front panel to enable YPbPr Clip. (To disable the function, press **DIF** again.)

(2) The following process control settings are available.

Y LEVEL	Y signal White clipping
C LEVEL	C signal White clipping
SETUP/BLACK	Y signal Black clipping

(3) Adjust the clip setting while viewing the three indicators above the controls and the value on the MEMORY/SET display panel. (See “Signal levels and level display” below.) Pressing the **UNITY** button below the value resets the clip value to the default.

(4) Repeat steps (2) and (3) to enter additional adjustments.

IMPORTANT
Note that changes are applied to all linked FS channels (FS Link On) in an FA-505, FA-1010 or FA-9520 (FA-9520 mode). See section 11. “FS Link” for more details.

◆ Signal levels and level display

The relationship between indicators, controls, and clip settings are as shown below.

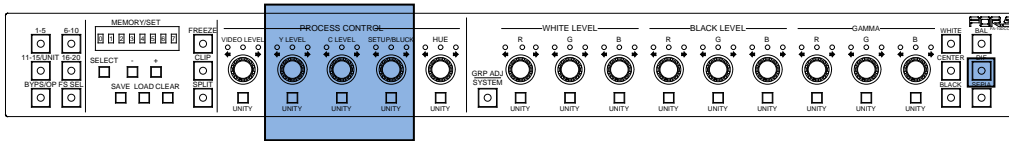

① Y White Clip Level

Setting range: 50% - 109%

Default (UNITY): 109%

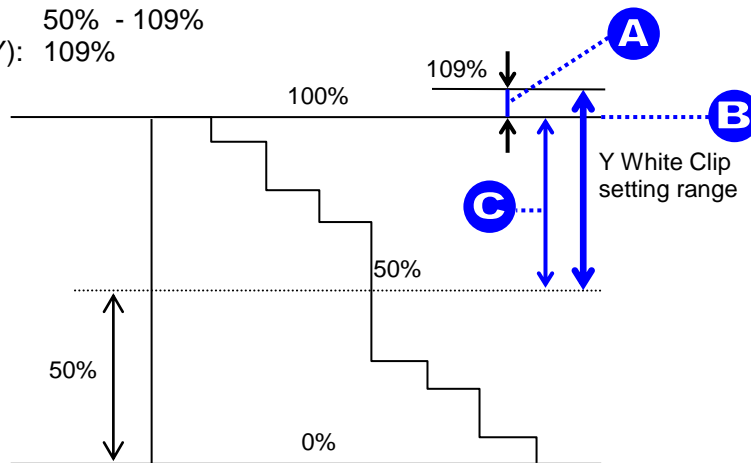

SMPTE 100% color bars when 100% white

Button	Setting	Level indicators	Panel display
Y LEVEL	A	Lit orange Flashes at 109% (UNITY).	101% - 109%
	B	Lit green	100%
	C	Lit orange Flashes at 50%	50% - 99%

② Y Black Clip Level

Setting range: -7.5% - 50%

Default (UNITY): -7.5%

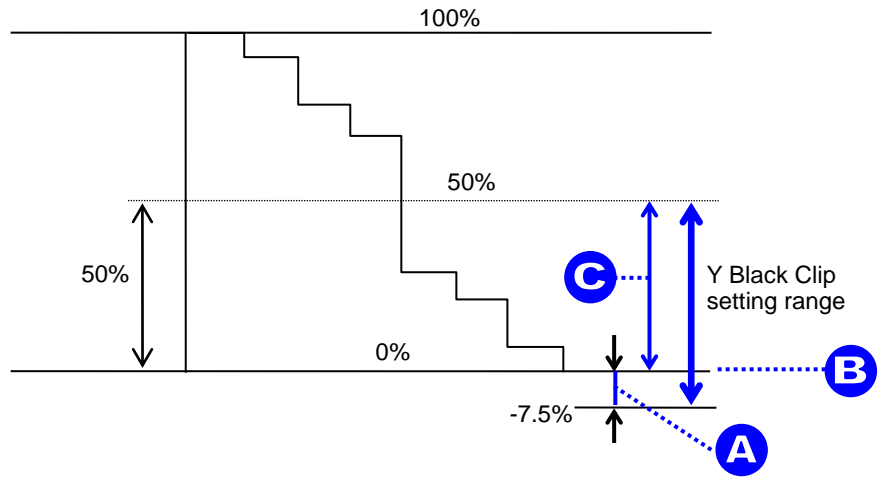

SMPTE 100% color bars when 100% black

Button	Setting	Level indicators	Panel display
SETUP/ BLACK	A	Lit orange. Flashes at -7% (UNITY)	-7.5% - -1%
	B	Lit green	0%
	C	Lit orange. Flashes at 50%.	1% - 50%

③ C White Clip Level

Setting range: 50% - 111%

Default (UNITY): 111%

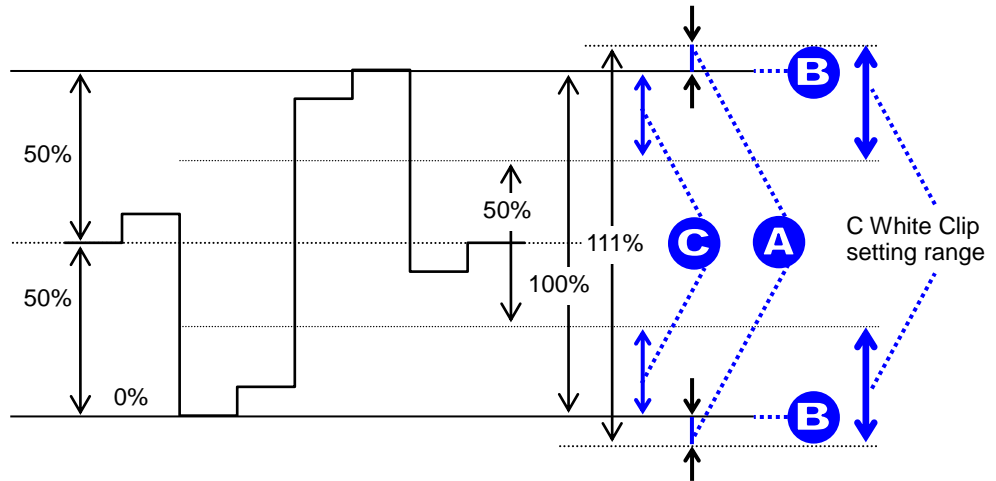

SMPTE 100% color bars when color 700mVp-p

Button	Setting	Level indicators	Panel display
C LEVEL	A	Lit orange. Flashes at 111% (UNITY)	101% - 111%
	B	Lit green	100%
	C	Lit orange. Flashes at 50%.	50% - 99%

6-10-2. RGB Clip

(1) With **CLIP** flashing, press **BAL** on the right end of the front panel to enable RGB Clip. (To disable, press **BAL** again.)

(2) The following process control settings are available.

Y LEVEL	White clipping of RGB signal
SETUP/BLACK	Black clipping of RGB signal

(3) Adjust the clip setting while viewing the three indicators above the controls and the value on the MEMORY/SET display panel. (See “Signal levels and level display” below.) Pressing the **UNITY** button below the value resets the clip value to default.

(4) Repeat steps (2) and (3) to enter additional adjustments.

◆ Signal levels and level display

The relationship between indicators, controls, and clip settings are as shown below.

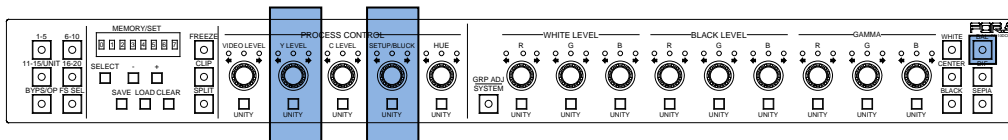

① RGB WHITE LEVEL (YLEVEL)

Setting range: 50% - 300%

Default (UNITY): 300%

Button	Setting	Level indicators	Panel display
Y LEVEL	A	Lit orange. Flashes at 300% (UNITY)	101% - 300%
	B	Lit green	100%
	C	Lit orange. Flashes at 50%.	50% - 99%

② RGB BLACK LEVEL (SETUP/BLACK)

Setting range: -200% - 50%

Default (UNITY): -200%

Button	Setting	Level indicators	Panel display
SETUP/ BLACK	A	Lit orange. Flashes at 200% (UNITY)	-200% - -1%
	B	Lit green	0%
	C	Lit orange. Flashes at 50%.	1% - 50%

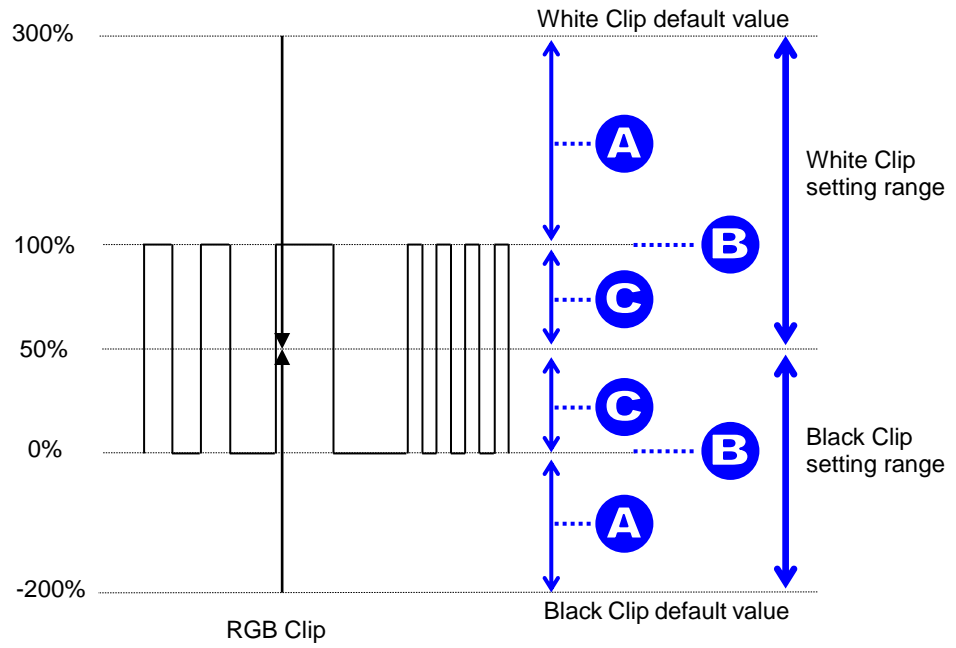

IMPORTANT

Note that changes are applied to all linked FS channels (FS Link On) in an FA-505, FA-1010 or FA-9520 (FA-9520 mode). See section 11. "FS Link" for more details.

6-11. Verifying Settings

Repeatedly pressing the **[+]** (or **[-]**) button displays settings one after another. Settings are not displayed while **FS SEL** is lit.

6-11-1. When in Color Correction Mode

When in BALANCE or DIFFERENTIAL Correction Mode, repeatedly pressing the **[+]** button displays settings one after another in the following order.

Video Level→Y Level→C Level→Setup/Black→Hue→
White R Level→White G Level→White B Level→
Black R Level→Black G Level→Black B Level→
Gamma R Level→Gamma G Level→Gamma B Level

* Pressing the **[-]** button displays settings in the reverse order.

When in SEPIA Correction Mode, repeatedly pressing the **[+]** button displays settings one after another in the following order.

Video Level→Y Level→Sepia Level→Setup/Black→Sepia Color→Gamma G Level

* Pressing the **[-]** button displays settings in the reverse order.

6-11-2. When in Clip Mode

Pressing **[+]** in RGB Clip mode (and with **FS SEL** unlit) displays the following settings.

RGB White Clip→RGB Black Clip

* Pressing the **[-]** button displays settings in the reverse order.

Pressing **[+]** in YPbPr Clip mode (and with **FS SEL** unlit) displays settings in the following order.

Y White Clip→Chroma Clip→Y Black Clip

* Pressing the **[-]** button displays settings in the reverse order.

IMPORTANT

Repeatedly pressing the **[+]** (or **[-]**) button displays settings one after another. When the end setting is reached, the display returns to the top item. If the control is turned while displaying settings using the **[+]** button, the changed setting is displayed. Pressing the **[+]** button after that displays the next setting of the setting displayed before the control is turned.

Example: Pressing the **[+]** button and adjusting SETUP/BLACK while Y LEVEL (YL 100%) is displayed shows "SB 10%". Pressing the **[+]** button after that displays "Hue 0°."

The **[-]** button works in the same way but in the reverse direction.

7. Event Memory

7-1. About Event Memory

Event Memory allows you to save FA-10DCCRU settings and load them when needed. EVENT MEMORY can store 100 (1-100) settings, which are saved in the FA-10DCCRU and cannot be used from main units.

In the following situations, event operations are disabled:

- ◆ **While selecting an FS for FA-505, FA-1010 or FA-9520 in FA9520 mode (FS SEL is lit)**
To enable event operation, press **FS SEL** to turn off the button light.
- ◆ **While in System Settings (GRP ADJ/SYSTEM is flashing)**
To enable event operation, press **GRP ADJ/SYSTEM** to exit the System setting mode.
- ◆ **While Changing Connection Mode (FS SEL is flashing)**
To enable event operation, press **SELECT** or **FS SEL** to complete the change, or complete the connection process.
- ◆ **While Selecting a Unit ID (11-15 UNIT is flashing)**
To enable event operation, complete the connection process.

7-2. Data Stored in Events

- ◆ **When connecting an FA-505, FA-1010 or FA-9520 (in FA9520 mode)**
The current FS settings are saved to events.
- ◆ **When connecting an FA-9520 (in FA-9500 mode) or FA-9500**
The FA-9520 or FA-9500 settings are saved to events.

7-3. Data Loaded from Events

- ◆ **When connecting an FA-505, FA-1010 or FA-9520 (in FA9520 mode)**
Event data is loaded to the current FS.
- ◆ **When connecting an FA-9520 (in FA-9500 mode) or FA-9500**
Event data is loaded to the Main Unit.

7-4. Saving Settings to Events

Once all setup settings are completed, save the settings to event memory using the following procedure.

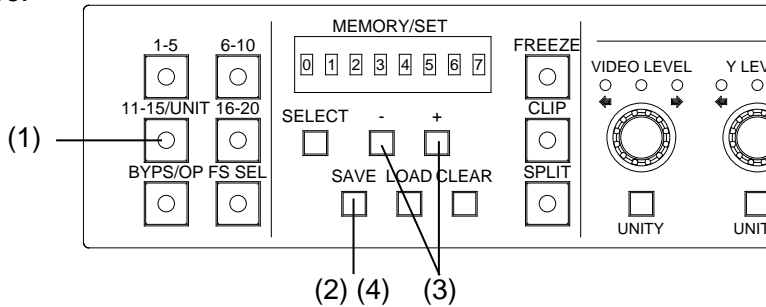

- (1) When connecting to an FA-505, FA-1010 or FA-9520, select an FS.
- (2) Press **SAVE**. A beep will sound and an event number is displayed. The event memory number will appear. (To cancel the process, press **CLEAR**.)
- (3) If you need to change the event number, use **+** and **-** to select the desired number (**Event1 - Event100**)

Press **+** and **-** to increase and decrease the number.
 Holding down **+** or **-** for several seconds quickly increases and decreases the number.
 Pressing **UNITY** of VIDEO LEVEL sets the number to Event1.

- (4) Press **SAVE**. A beep will sound and the current settings are saved to the selected event.

IMPORTANT		
Note that the following settings are not saved to event memory but are stored in the FA-10DCCRU.		
-BYPASS/OPERATE	-FREEZE	-GRP ADJ
-FS SEL	-SPLIT	

7-5. Loading Settings from Events

Follow the instructions below to load settings. Note that the current settings will be lost after settings are loaded.

- (1) When connecting to an FA-505, FA-1010 or FA-9520, select an FS.
- (2) Press the **LOAD** button. A beep sounds and the event memory number flashes. (To cancel the operation, press **CLEAR**.)
- (3) Select the memory number from **Default, Event0 to Event100** using the **+** and **-** (or VIDEO LEVEL) buttons.

Press **+** and **-** to increase and decrease the number.
 Holding down **+** or **-** for several seconds quickly increases and decreases the number.
 Pressing **UNITY** of VIDEO LEVEL sets to **Default**.

- (4) Press the **LOAD** button. After a beep, the data is loaded from the memory.

8. SYSTEM Settings

Press and hold the **[GRP ADJ/SYSTEM]** button to enter System Setting mode.

The **[GRP ADJ/SYSTEM]** button flashes in this mode.

Pressing the flashing **[GRP ADJ/SYSTEM]** button exits System Setting mode and the button functions as a Group ADJ On/Off.

The **[SELECT]** button allows you to select a setting. Successively pressing the button scrolls setting items in the following order. When the end setting is reached, the display returns to the top item.

- ① Unity Mode: Unlinked
↓
 - ② Front Buzzer: Enable
↓
 - ③ GPI Buzzer: Enable
↓
 - ④ Display Mode: Full
↓
 - ⑤ Display BRIGHT: 30%
↓
 - ⑥ GPI 1 No.1-10
↓
 - ⑦ GPI 2 No.11-20
↓
 - ⑧ GPI 3 No.21-30
↓
 - ⑨ IP: 192.168.0.101
↓
 - ⑩ Subnet 255.255.255.0
↓
 - ⑪ Gateway 0.0.0.0
↓
 - ⑫ FAN: Normal
↓
 - ⑬ Soft Ver: 2.10
↓
 - ⑭ FPGA1 Ver: 1.00
↓
 - ⑮ FPGA2 Ver: 1.00
↓
- Unity Mode: Unlinked (Back to the top)

IMPORTANT

Note that in System Setting mode system settings can be checked and changed without a main unit connection. Other settings cannot be performed in this mode.

8-1. System Settings

No.	Menu item	Setting buttons	Description
①	Unity Mode	<input type="checkbox"/> , <input type="checkbox"/> buttons	<input type="checkbox"/> Unlinked: UNITY is applied only to the relevant FS channel. <input type="checkbox"/> Linked: UNITY is applied to all linked FS channels. See section 11. "FS Link" for more details.
②	Front Buzzer	<input type="checkbox"/> , <input type="checkbox"/> buttons	<input type="checkbox"/> Disable: Disables the front buzzer. <input type="checkbox"/> Enable: Enables the front buzzer.
③	GPI Buzzer	<input type="checkbox"/> , <input type="checkbox"/> buttons	<input type="checkbox"/> Disable: Disables the buzzer for GPI settings. <input type="checkbox"/> Enable: Enables the buzzer for GPI settings.
④	Display Mode	<input type="checkbox"/> , <input type="checkbox"/> buttons	<input type="checkbox"/> Full: Displays settings in detailed format. <input type="checkbox"/> Simple: Displays settings in short format.
⑤	Display BRIGHT	<input type="checkbox"/> , <input type="checkbox"/> buttons	Sets front panel brightness. Options are 1.7%, 3.3%, 5%, 6.7%, 8.3%, 11.7%, 15%, 18%, 23%, 30%(default), 37%, 47%, 60%, 80% and 100%
⑥	GPI1 No.1-10	Rotary encoder (*1)	Sets brightness for GPI OUT LED indicators (No1 – 10) from 0 to 255. (Default: 50)
⑦	GPI2 No.11-20	Rotary encoder (*1)	Sets brightness for GPI OUT LED indicators (No11 – 20) from 0 to 255. (Default: 50)
⑧	GPI3 No.21-30	Rotary encoder (*1)	Sets brightness for GPI OUT LED indicators (No21 – 30) from 0 to 255. (Default: 50)
⑨	IP: 192.168.0.101	(Display only)	Displays the FA-10DCCRUIP address.
⑩	Subnet 255.255.255.0	(Display only)	Displays the FA-10DCCRUIP subnet mask.
⑪	Gateway 0.0.0.0	(Display only)	Displays the FA-10DCCRUIP default gateway.
⑫	FAN (*2)	(Display only)	Displays the FA-10DCCRUIP fan status. Normal: The fan is functioning normally. Stopped: The fan has stopped.
⑬	Software Ver: 2.00	(Display only)	Displays the software version.
⑭	FPGA1 Ver: 1.00	(Display only)	Displays the FPGA1 version.
⑮	FPGA2 Ver: 1.00	(Display only)	Displays the FPGA2 version.

(*1) See section 8-2. "GPI OUT LED Indicator Brightness Settings."

(*2) When the fan has stopped, turn off the unit power, notify your FOR-A reseller or supplier and change the fan.

8-2. GPI OUT LED Indicator Brightness Settings

GPI OUT No.	Controller	System menu item (GPI connector)	FA-AUX30 block
GPI- OUT 1	VIDEO LEVEL	⑦ GPI1 No.1-10 (GPI1)	Left block
GPI- OUT 2	Y LEVEL		
GPI- OUT 3	C LEVEL		
GPI- OUT 4	SETUP/BLACK		
GPI- OUT 5	HUE		
GPI- OUT 6	WHITE LEVEL R		
GPI- OUT 7	WHITE LEVEL G		
GPI- OUT 8	WHITE LEVEL B		
GPI- OUT 9	BLACK LEVEL R		
GPI- OUT 10	BLACK LEVEL G		
GPI- OUT 11	VIDEO LEVEL	⑧ GPI2 No.11-20 (GPI2)	Center block
GPI- OUT 12	Y LEVEL		
GPI- OUT 13	C LEVEL		
GPI- OUT 14	SETUP/BLACK		
GPI- OUT 15	HUE		
GPI- OUT 16	WHITE LEVEL R		
GPI- OUT 17	WHITE LEVEL G		
GPI- OUT 18	WHITE LEVEL B		
GPI- OUT 19	BLACK LEVEL R		
GPI- OUT 20	BLACK LEVEL G		
GPI- OUT 21	VIDEO LEVEL	⑨ GPI3No.21-30 (GPI3)	Right block
GPI- OUT 21	Y LEVEL		
GPI- OUT 23	C LEVEL		
GPI- OUT 24	SETUP/BLACK		
GPI- OUT 25	HUE		
GPI- OUT 26	WHITE LEVEL R		
GPI- OUT 27	WHITE LEVEL G		
GPI- OUT 28	WHITE LEVEL B		
GPI- OUT 29	BLACK LEVEL R		
GPI- OUT 30	BLACK LEVEL G		

* See section 10-4. "GPI1-GPI3 Pin Assignments."

9. Information Display

While setting up the FA-10DCCRU, relevant information is displayed on the 8-digit display in two modes (**Full** and **Simple**). The following Information Display lists show when these information messages are displayed.

Full: Displays information or message in detailed format. Note that while setting menu items, information is displayed in Simple mode and about 2 seconds after entering a setting, it is displayed in Full mode.

Simple: Displays information or message in short format.

* To change the display mode, set under ④ **Display Mode** (See section 8. "SYSTEM Settings.")

9-1. Messages during Main Unit Connection

(**: Setting values)

Displayed message (Full / Simple)	When information/message is displayed:	Refer to
Please Choose Direct MU No	FA-10DCCRU is in Direct Connection mode, but no main unit is selected. Connect to a main unit using 1-5, 6-10, 11-15 or 16-20 button.	6-1-2
ID**	When FA-10DCCRU is connected to a main unit in Unit ID Connection mode, its Unit ID number is displayed.	6-1-1
Disconnect	FA-10DCCRU is in Unit ID Connection mode, but no main unit is connected. It is also displayed while trying to connect to a main unit.	6-1-1 6-1-2
ID**: No IP Address Assigned	FA-10DCCRU is trying to connect to a main unit in Unit ID Connection mode, but no IP address has been set for the specified Unit ID number.	6-1-1
ID**: IP**: **: **: ** (No Name)	When FA-10DCCRU is connected to a main unit in Unit ID Connection mode and no Unit Name is set for the main unit, its IP address is displayed.	6-1-1
ID**: FA-1010	When FA-10DCCRU is connected with a main unit, its Unit Name is displayed.	6-1-1
Direct Mode Connection	While changing the connection mode to Direct .	6-1-2
Unit Mode Connection	While changing the connection mode to Unit ID .	6-1-1
No Assigned IP Address	FA-10DCCRU is trying to connect to a main unit in Direct Connection mode by pressing a number button (1-5, 6-10, 11-15 or 16-20), but no IP address has been set for the specified MU ID number. Set an IP address for the MU ID (Unit ID) number.	6-1-1
Connecting(Direct)	FA-10DCCRU is connecting to a main unit in Direct Connection mode. If the connection time is too short, the message may not appear.	6-1-1
Connecting (Unit)	FA-10DCCRU is connecting to a main unit in Unit ID Connection mode. If connection time is too short, the message may not appear.	6-1-2
No Connection Established (IP **: **: **: **)	When the FA-10DCCRU fails to connect to a main unit, the message and specified main unit IP address are displayed. Verify the network connection and settings. Note that the FA-10DCCRU will attempt to connect to the main unit while the message is being displayed.	6-1

Displayed message (Full / Simple)	When information/message is displayed:	Refer to
Over Limit (IP **. **. **. **)	When FA-10DCCRU is attempting to connect to a main unit, the main unit has connected with 5 remote control units (maximum) and this connection fails. To connect to the main unit, the main unit must disconnect one of the connected remote control units. This message may also be displayed when a disconnection is being improperly performed. Note that it will take 1 minute at most to complete the disconnection process.	6-1
Connected: IP **. **. **. ** (No Name)	When FA-10DCCRU is connected to a main unit in Direct Connection mode and no Unit Name is set for the main unit, its IP address is displayed. The message is cleared when there is no operation within 1 minute.	
Connected: FA-1010	When FA-10DCCRU is connected to a main unit in Direct Connection mode, the message is displayed with its Unit Name (FA-1010) for about 7 seconds.	6-1
MU is Local Mode	When the FA-10DCCRU is connected to a main unit, but the main unit operates in local mode, this message will appear and the main unit cannot be controlled from the FA-10DCCRU. To control the main unit, change the operation mode to Remote in the main unit.	-

9-2. Messages during Bypass Setting

Displayed message (Full / Simple)	When information/message is displayed:	Refer to
By-pass	Displayed when the connected FA-505/FA-1010 is set to Bypass .	6-2
Operate (*1)	Displayed when the connected FA-505/FA-1010 is set to Operate .	6-2
By-pass No Support (*1)	Displayed when trying to set to Bypass for the main unit that has no bypass function.	2 6-2

(*1) The display is automatically turned off when there is no operation within 1 minute.

9-3. Messages during FS Selection

Displayed message (Full)	Displayed message (Simple)	When information/message is displayed:	Refer to
FS*	(Same as in Full mode)	FS number of connected FA-9520 (9520 mode).	6-3
FS*: FS1 Name	FS*	FS number and FS Name (FS1 Name) of connected FA-505/FA-1010.	6-3
FS*(No Name)	FS*	FS number (without FS Name) of connected FA-1010. See the FA-505/FA-1010 Operation Manual for details on how to assign names to FSs.	6-3
FS Select No Support	(Same as in Full mode)	Displayed when attempting to select an FS for an FA-9520 (FA-9500 mode) or FA-9500. The display is automatically turned off when there is no operation within 1 minute.	2 6-3

9-4. Messages during Event Memory Operation

Displayed message (Full)	Displayed message (Simple)	When information/message is displayed:	Refer to
Default	Default	Displayed when default settings are being loaded.	7-3
Load **: Event1	Load **	Event number and name (Event1 in this example) displayed when loading an event.	5-3-6 7-3
Load ** (No Name)	Load **	Event number (with no name) displayed when loading an event.	5-3-6 7-3
Loading	(Same as in Full mode)	Displayed while loading events.	7-3
Loaded Default (*1)	(Same as in Full mode)	Displayed when an event with default settings has been loaded.	7-3
Loaded Event** (*1)	(Same as in Full mode)	Displayed when an event with no name has been loaded.	5-3-6 7-3
Loaded Event**: Event1 (*1)	(Same as in Full mode)	Displayed when a named event (Event1) has been loaded.	5-3-6 7-3
Save **: Event1	Save **	Event number and name (Event1) displayed when saving settings to an event.	5-3-6 7-2
Save ** (No Name)	Save **	Event number (with no name) displayed when saving settings to an event.	5-3-6 7-2
Saving	(Same as in Full mode)	Displayed while saving settings to events.	7-2
Saved Event** (*1)	(Same as in Full mode)	Displayed when settings have been saved to an event with no name.	5-3-6 7-2
Saved Event**: Event1 (*1)	(Same as in Full mode)	Displayed when settings have been saved to a named event (Event1).	5-3-6 7-2

(*1) The display is automatically turned off when there is no operation within 1 minute.

9-5. Messages during Freeze Setting

Displayed message (Full)	Displayed message (Simple)	When information/message is displayed:	Refer to
Freeze On	(Same as in Full mode)	Displayed when Freeze is set to On.	6-4
Freeze Off	(Same as in Full mode)	Displayed when Freeze is set to Off.	6-4

The display is automatically turned off when there is no operation within 1 minute.

9-6. Messages during Split Setting

Displayed message (Full)	Displayed message (Simple)	When information/message is displayed:	Refer to
Split: Off	Off	Displayed when Split is set to Off.	6-5
Split: Mode1	Mode1	Displayed when Split is set to Mode1.	6-5
Split: Mode2	Mode2	Displayed when Split is set to Mode2.	6-5
Split: Mode3	Mode3	Displayed when Split is set to Mode3.	6-5
Split No Support	(Same as in Full mode)	Displayed when trying to set Split to a main unit that has no Split function.	2 6-5

The display is automatically turned off when there is no operation within 1 minute.

9-7. Messages during Proc Amp Settings

In Full display mode, text in parentheses are displayed during menu settings. When verifying settings using \square and \oplus buttons, information is displayed in Simple display mode.

Displayed message (Full)	Displayed message (Simple)	When information/message is displayed:	Refer to
Video Level: ***. *% (***. *%)	VL ***%	Displayed when the Video Level setting is changed.	6-8
Y Level: ***. *% (***. *%)	YL ***%	Displayed when the Y Level setting is changed.	6-8
Y Level No Support	(Same as in Full mode)	Displayed when trying to change the Y Level setting of a main unit with no Y Level parameters.	2
Chroma Level: ***. *% (***. *%)	CL ***%	Displayed when the Chroma Level setting is changed.	6-8
Setup/Black: ***. *% (***. *%)	BL ***%	Displayed when the Setup/Black Level setting is changed.	6-8
Hue: *. *° (*. *°)	Hue *°	Displayed when Hue is changed.	6-8



The display is automatically turned off when there is no operation within 1 minute.

When Color Correction mode is set to Sepia:

Displayed message (Full)	Displayed message (Simple)	When information/message is displayed:	Refer to
Sepia Level : ***. *% (***. *%)	SL ***%	Displayed when the Sepia Level setting is changed.	6-8 6-9
Sepia Color: *. *° (***. *°)	SC *°	Displayed when the Sepia Color setting is changed.	6-8 6-9

The display is automatically turned off when there is no operation within 1 minute.

9-8. Messages during Color Correction Settings



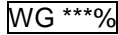
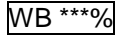
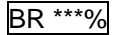
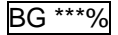
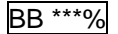
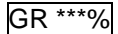
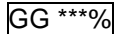
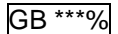

In Full display mode, text in parentheses are displayed during menu settings.
When verifying settings using  and  buttons, information is displayed in Simple display mode.

See section 6-9. "Color Correction" for more details.

Displayed message (Full)	Displayed message (Simple)	When information/message is displayed:
White R Level: ***. *% (***. *%)		Displayed when the White R Level setting is changed.
White G Level: ***. *% (***. *%)		Displayed when the White G Level setting is changed.
White B Level: ***. *% (***. *%)		Displayed when the White B Level setting is changed.
Black R Level: ***. *% (***. *%)		Displayed when the Black R Level setting is changed.
Black G Level: ***. *% (***. *%)		Displayed when the Black G Level setting is changed.
Black B Level: ***. *% (***. *%)		Displayed when the Black B Level setting is changed.
Gamma R Level: ***. *% (***. *%)		Displayed when the Gamma R Level setting is changed.
Gamma G Level: ***. *% (***. *%)		Displayed when the Gamma G Level setting is changed.
Gamma B Level: ***. *% (***. *%)		Displayed when the Gamma B Level setting is changed.



The display is automatically turned off when there is no operation within 1 minute.

In Full display mode, text in parentheses are displayed during menu settings.



Displayed message (Full)	Displayed message (Simple)	When information/message is displayed:
Curve White (White)		Displayed when Gamma Curve is set to White.
Curve Center (Center)		Displayed when Gamma Curve is set to Center.
Curve black (Black)		Displayed when Gamma Curve is set to Black.
Balance	(Same as in Full mode)	Displayed when Color Correction Mode is set to Balance.
Differential (DIF)		Displayed when Color Correction Mode is set to Differential.
Sepia	(Same as in Full mode)	Displayed when Color Correction Mode is set to Sepia.

The display is automatically turned off when there is no operation within 1 minute.

9-9. Messages during Video Clip Settings

In Full display mode, text in parentheses are displayed during menu settings. When verifying settings using  and  buttons, information is displayed in Simple display mode.

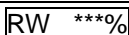
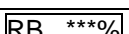
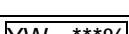
See section 6-10. "Clipping Signal Levels" for more details.

Displayed message (Full)	Displayed message (Simple)	When information/message is displayed:
Clip Off	(Same as in Full mode)	Displayed when Video Clip Mode is set to Off.
RGB Clip	(Same as in Full mode)	Displayed when Video Clip Mode is set to RGB.
YPbPr Clip (YPbPr)		Displayed when Video Clip Mode is set to YPbPr.
RGB White Clip: ***.*% (***.*%)		Displayed when the RGB White Clip Level setting is changed.
RGB Black Clip: ***.*% (***.*%)		Displayed when the RGB Black Clip Level setting is changed.
Y White Clip: ***.*% (***.*%)		Displayed when the Y White Clip Level setting is changed in YPbPr mode.
Y Black Clip: ***.*% (***.*%)		Displayed when the Y Black Clip Level setting is changed in YPbPr mode.
Chroma Clip: ***.*% (***.*%)		Displayed when the Chroma Clip Level setting is changed in YPbPr mode.

The display is automatically turned off when there is no operation within 1 minute.

9-10. Messages during System Settings

Text in parentheses are displayed during menu settings.
See section 8. "System Settings" for more details.

Displayed message (Full / Simple)	When information/message is displayed:
Unity Mode: Unlinked	Displayed while Unity Mode is being set to Unlinked.
Unity Mode: Linked	Displayed while Unity Mode is being set to Linked.
Front Buzzer: Enable	Displayed while Front Buzzer is being enabled.
Front Buzzer: Disable	Displayed while Front Buzzer is being disabled.
GPI Buzzer: Enable	Displayed while GPI Buzzer is being enabled.
GPI Buzzer: Disable	Displayed while GPI Buzzer is being disabled.
Display Mode: Full	Displayed while Display Mode is being set to Full.
Display Mode: Simple	Displayed while Display Mode is being set to Simple.
Display BRIGHT: **%	Displayed while Brightness is being changed.
GPI1 No.1-10	Displayed when entering the GPI1 Brightness setting.
GPI2 No.11-20	Displayed when entering the GPI2 Brightness setting.
GPI3 No.21-30	Displayed when entering the GPI3 Brightness setting.
GPI Port* BRIGHT: ** (No.* : **)	Displayed while a GPI OUT LED Brightness is being changed.
IP: **. **. **. **	IP address of FA-10DCCRU.
Subnet: **. **. **. **	Subnet mask of FA-10DCCRU
Gateway: **. **. **. **	Default gateway of FA-10DCCRU
FAN: Normal	Displayed when the FA-10DCCRU FAN is functioning normally.
FAN: Stopped	Displayed when the FA-10DCCRU FAN has stopped.
Soft Ver: *. **	Software version of FA-10DCCRU
FPGA1 Ver: *. **	FPGA1 version of FA-10DCCRU
FPGA2 Ver: *. **	FPGA2 version of FA-10DCCRU

Other

Factory Setting	Displayed when resetting to factory default settings. See section 12. "Resetting to Factory Default Settings."
-----------------	-------------------------------------------------------------------------------------------------------------------

10. GPI Interface

GPI input /output functions can be assigned to GPI ports 1-30 (GPI 1-3 connectors) on the FA-10DCCRU using the supplied FA GPIO Editor software.

GPI input and output functions can be assigned to ports individually or in 10-port groups. (See section 10-4.)

GPI settings can be backed up to and restored from files using Export and Import. (See section -2)

10-1. FA-GPIO Editor

10-1-1. Installing the FA GPIO Editor

Use the supplied CD-ROM to install the FA GPIO Editor software.

Before installing this software, close all other applications on the computer.

(1) Insert the supplied CD-ROM into the PC. Click “FA GPIO Editor > setup “ on the CD-ROM to start the installation wizard.

(2) Click **Next**.

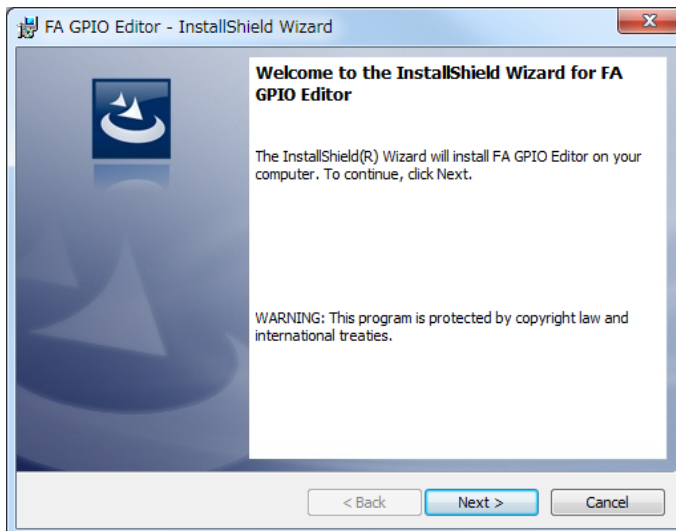

(3) The Software License Agreement window appears. Read the agreement statement and check the **I accept the terms in license agreement** check box, then click **next**. To cancel the installation, click **Cancel**.

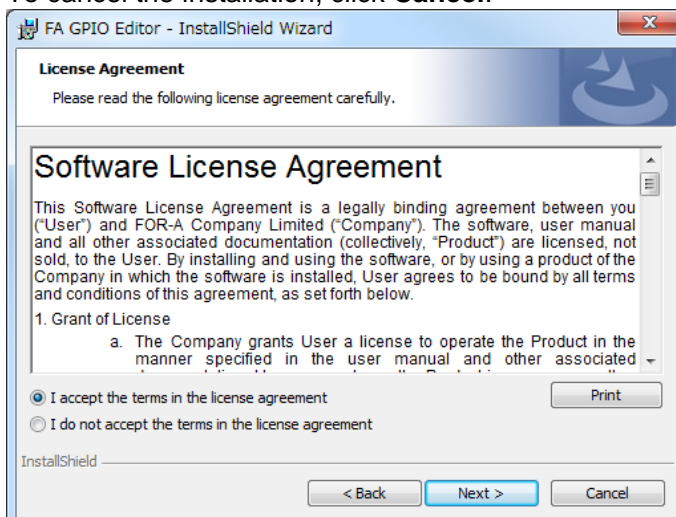

NOTE

To print the Software License Agreement, click **Print**. Before printing the License agreement, verify that your printer is actually connected to the PC.

(4) The installation directory of the FA GPIO Editor is displayed.
To change the default installation directory, click **Change...** and specify a new directory.

(5) Click **Next**.

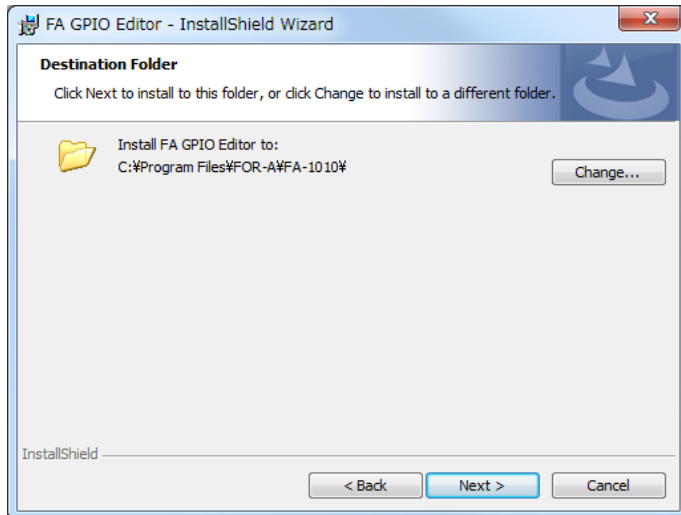

(6) The last wizard page is displayed. Verify the installation settings and click **Install** to install the software.

To change settings, click on **Back**, change installation settings as required, then click **Install**.

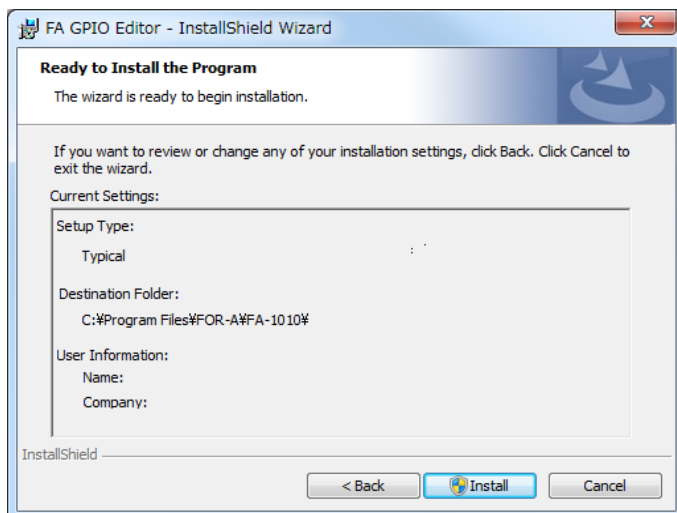

(7) When the software installation is complete, the window as shown below will appear. Click **Finish** to finish the installation.

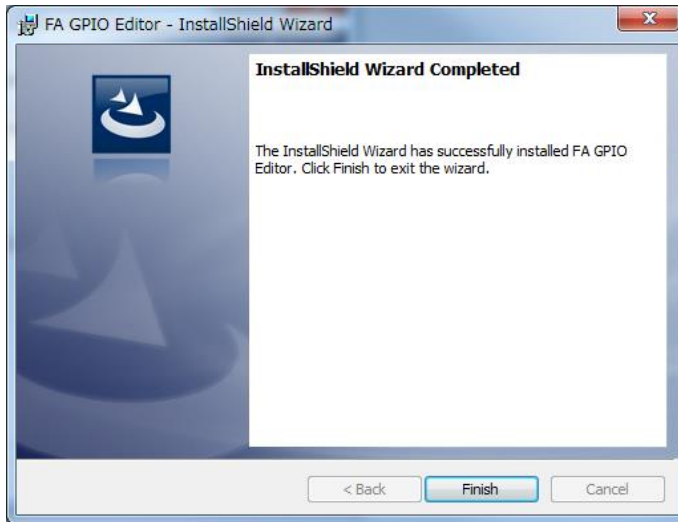

10-2. About the FA GPIO Editor

GPI input /output functions can be assigned to 30 GPI ports (GPI 1-3 connectors) on the FA-10DCCRUC using the supplied FA GPIO Editor software.

GPI assignments are very flexible: an input or output or both can be assigned to a port, GPI pulse signals can be output inversely and assignments can be performed individually or in groups using Pattern Load.

In addition, GPI settings can be backed up to and restored from files using Export and Import.

10-2-1. Connecting FA GPIO Editor to the FA-10DCCRUC

(1) Click the FA GPIO Editor shortcut icon on the desktop to start FA GPIO Editor.



(2) When the software window appears, enter the FA-10DCCRUC IP address, user name and password. Click **Load**.

< Default FA-10DCCRUC settings >

IP address: **192.168.0.101**

User name: **fa10dccru**

Password: **foranetwork**

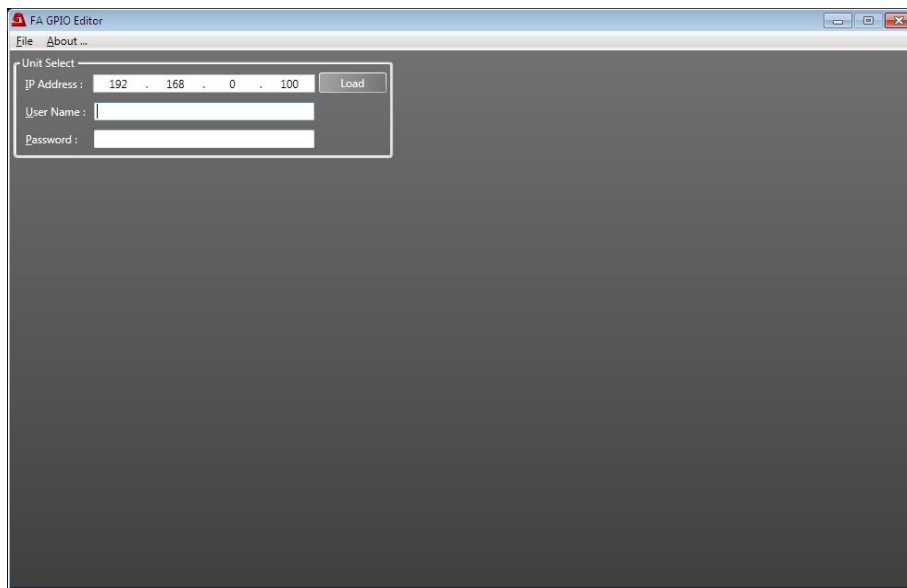

(3) When the user name and password are accepted, a window as shown below is displayed and FA-10DCCRU GPI settings are loaded in the window.

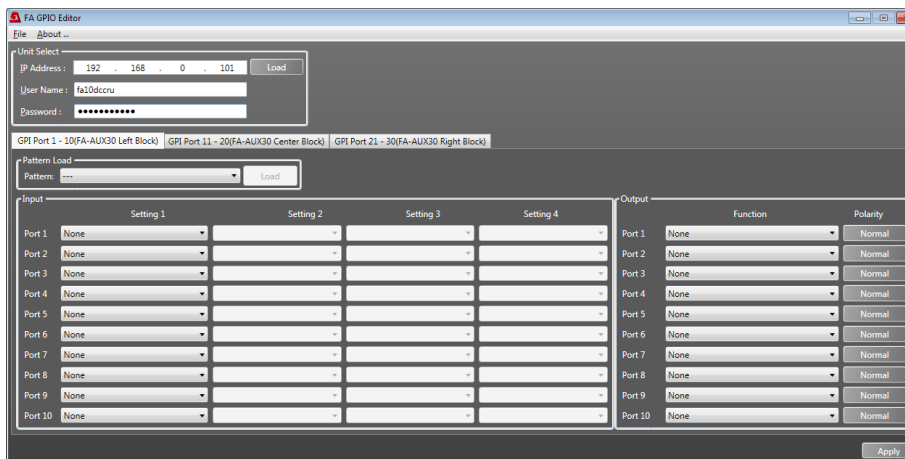

When the user name and password are not accepted, the following pop-up dialog windows appears. Click **OK** to close the dialog. Enter the correct user name and password and click **Load**.

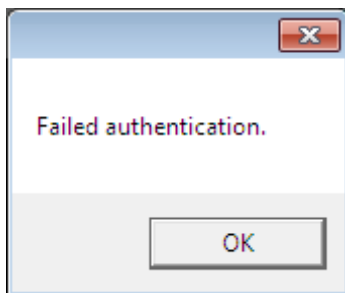

10-2-2. Loading and Assigning GPI Functions

As factory default, GPI functions are all set to **None (no function)**.

Use the FA-GPIO Editor to perform GPI assignments for GPI1 - 3 (Ports 1-30) connectors.

Select a GPI connector (10 ports) by clicking a tab from the following three:

GPI Port 1 - 10(FA-AUX30 Left Block)

GPI Port 11 - 20(FA-AUX30 Center Block)

GPI Port 21 - 30(FA-AUX30 Right Block)

Note that "(FA-AUX30...)" indicates a button block (seen from the front side) when connecting an FA-AUX30 unit.

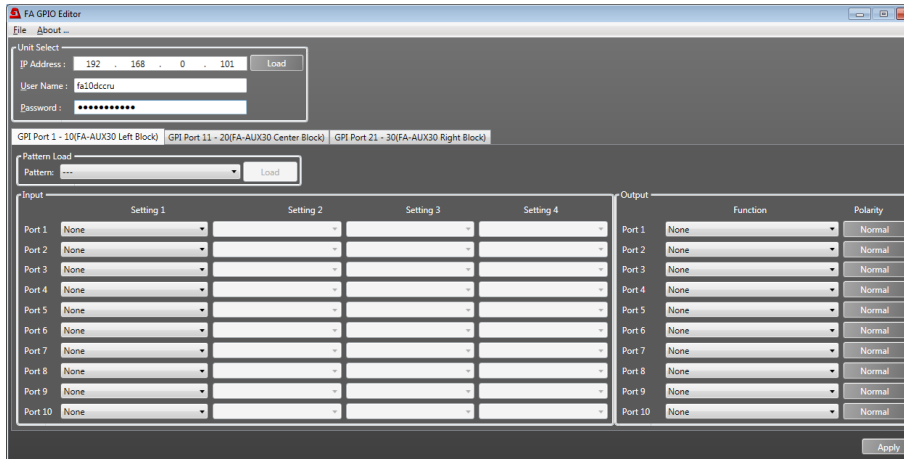

10-2-3. GPI Input Settings

A combination of GPI input settings (**Setting 1**, **Setting 2** and **Setting 3**) can be assigned to each GPI port.

GPI ports are activated when they are closed with a common port.

(1) First, set **Setting 1**. To disable ports, set **None** under Setting 1.

Detailed Input Settings

Setting 1 setting	Description	Refer to
None	No function	-
MU Select	MU Select allows you to select a main unit under Setting 2 (Unit ID1 - 100) and an FS of the main unit under Setting 3 (FS1 - 10). If set to None under Setting 3, the last controlled FS is selected. Main unit IP addresses must be set for Unit ID numbers in advance. If set to Disconnect under Setting 2, the port can disconnect main units.	5-3-4
FS Select	FS Select allows you to select an FS under Setting 2, FS1 - FS10 if connecting to FS-1010 and FS1 or FS2 if connecting to FA-9520 (FA-9520 mode). FS Select is inoperative when connecting with FA-9520 (FA-9500 mode) or FA-9500 units.	-
FS Link (toggled On/Off)	Allows you to link or unlink an FS under Setting 2. If All Clear is set under Setting 2, all FS channels are unlinked.	11
Freeze (toggled On/Off)	Allows you to set Freeze to On or Off. If an FS is selected under Setting 2, the controlled FS is changed to the selected one and a Freeze setting is applied to it. If None is set under Setting 2, a Freeze setting applies to the current FS.	6-4
Split Mode	Allows you to set Split mode under Setting 2. If an FS is selected under Setting 3, the controlled FS is changed to the selected one and a Split Mode setting is applied to it. If None is set under Setting 3, a Split Mode setting applies to the current FS.	6-5
CC Mode	Allows you to set Color Correction mode under Setting 2. If an FS is selected under Setting 3, the controlled FS is changed to the selected one and a CC Mode setting is applied to it. If None is set under Setting 3, a CC Mode setting applies to the current FS.	6-9
Gamma Curve	Allows you to set Gamma Curve under Setting 2. If an FS is selected under Setting 3, the controlled FS is changed to the selected one and a Gamma Curve setting is applied to it. If None is set under Setting 3, a Gamma Curve setting applies to the current FS.	6-9
Clip	Allows you to set Clip mode under Setting 2. If an FS is selected under Setting 3, the controlled FS is changed to the selected one and a Clip setting is applied to it. If None is set under Setting 3, a Clip setting applies to the current FS.	6-10
GPI Lock (toggled On/Off)	Allows you to enable (GPI Lock Off) / disable (GPI Lock On) all GPI inputs.	-
Group Adjust (toggled On/Off)	Allows you to enable / disable group adjustment. The group adjustment functions are adjusted in the same manner as those in FA-10DCCRU.	6-9
Event Load	Allows you to load an event set under Setting 2 (Event1 - 100).	7
Event Save	Allows you to save settings to an event set under Setting 2 (Event1 - 100).	7

(2) Set **Setting 2** and **Setting 3** according to **Setting 1**.

Input Setting List

Port No.	Setting 1	Setting 2	Setting 3
1 - 30	None	-	-
	MU Select	Disconnect	-
		Unit ID1 - 100	None FS1 - FS10
	FS Select	FS1 - FS10	-
	FS Link(On/Off)	All Clear FS1 - FS10	-
	Freeze(On/Off)	None FS1 - FS10	-
	Split Mode	Off Mode1 - 3	None FS1 - FS10
	CC Mode	Balance Differential Sepia	None FS1 - FS10
	Gamma Curve	Center Black White	None FS1 - FS10
	Clip	Off YPbPr RGB	None FS1 - FS10
	GPI Lock(On/Off)	-	-
	Group Adjust(On/Off)	-	-
	Event Load	Default Event1 - 100	-
	Event Save	Event1 - 100	-

10-2-4. GPI Output Settings

Available GPI output functions are shown below.

Output Setting List

Port No.	Function	When tally signals are supplied
Port 1 - 30	None	No tally output
	Follow GPI In Settings	When the input function of the same port is enabled.
	All DC/FAN Alarm ^(*1)	When one or more cooling fans or power supply units in the main unit and FA-10DCCRU fail.
	FA-10DCCRU FAN Alarm	When the FA-10DCCRU cooling fan fails.
	MU/FA-10DCCRU FAN Alarm	When one or more cooling fans in the main unit and FA-10DCCRU fail.
	MU FAN1 Alarm	When FAN1 in the main unit fails.
	MU FAN2 Alarm	When FAN2 in the main unit fails.
	MU FAN3 Alarm ^(*2)	When FAN3 in the main unit fails.
	MU FAN4 Alarm ^(*2)	When FAN4 in the main unit fails.
	DC Power Alarm ^(*3)	When one or more power supply units in the main unit fail.
	DC Power1 Alarm ^(*3)	When Power Supply 1 in the main unit fails.
	DC Power2 Alarm ^(*3)	When Power Supply 2 in the main unit fails.
	Reference Input Video Status	When a reference input video is detected in the main unit.
	FS1 Input Video Status	When an input video for FS1 is present in the main unit.
	FS2 Input Video Status ^(*4)	When an input video for FS2 is present in the main unit.
	FS3 Input Video Status ^(*5)	When an input video for FS3 is present in the main unit.
	FS4 Input Video Status ^(*5)	When an input video for FS4 is present in the main unit.
	FS5 Input Video Status ^(*5)	When an input video for FS5 is present in the main unit.
	FS6 Input Video Status ^(*2)	When an input video for FS6 is present in the main unit.
	FS7 Input Video Status ^(*2)	When an input video for FS7 is present in the main unit.
FS8 Input Video Status ^(*2)	When an input video for FS8 is present in the main unit.	
FS9 Input Video Status ^(*2)	When an input video for FS9 is present in the main unit.	
FS10 Input Video Status ^(*2)	When an input video for FS10 is present in the main unit.	

(*1) The system detects DC power alarm/s, as needed, for the second power supply in the main unit.

(*2) Used for FA-1010 connection.

(*3) Used for main units with redundant power supplies

(*4) Used for FA-505, FA-1010 or FA-9520 (in FA-9520 mode) connection

(*5) Used for FA-505 or FA-1010 connection

10-2-5. Inverting GPI Output Pulse Polarity

To invert the polarity of GPI output pulse, change **Polarity** from **Normal** to **Invert**. This function is used in such cases such as when inverting a tally condition, or using output devices that work in inverse logic. When connecting to FA-AUX30 units, set Polarity to **Normal**.

10-2-6. Sending GPI Settings

After all GPI settings are finished, click **Apply** to send all settings to the FA-10DCCRU unit. The following message indicates that GPI ports have successfully been set. Click **OK** to close the dialog window.

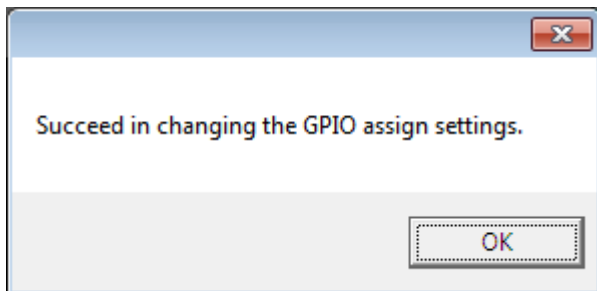

The following message indicates that GPI settings have failed. Click **OK** to close the dialog window. Verify the network connection and settings, then click **Apply** to reenter settings.



10-2-7. Pattern Load

The Pattern Load function allows you to assign GPIO functions in groups by loading patterns.

<Pattern Load Procedure>

- (1) Click to select a tab from **GPI Port 1 - 10(FA-AUX30 Left Block)**, **GPI Port 11 - 20(FA-AUX30 Center Block)** and **Port 21 - 30(FA-AUX30 Right Block)**.
- (2) Click on the Pattern box to select a pattern from the dropdown menu.
- (3) Click **Load** to load the pattern. Ten GPI input/output ports are quickly set. Loaded settings can be changed in the same manner as that of assignments. (See section 10-2-3. "GPI Input Settings" and section 10-2-4. "GPI Output Settings.")
- (4) After all GPI settings are finished, click **Apply** to send the settings to the FA-10DCCRU unit. If a "Successful settings" message appears, GPI settings are complete.

See section 10-2-8. "GPI Pattern List" for details on GPI patterns.

10-2-8. Exporting GPI Settings to Files

GPI settings can be backed up to and loaded from files in the computer.

Select **File > Export** in the menu bar.

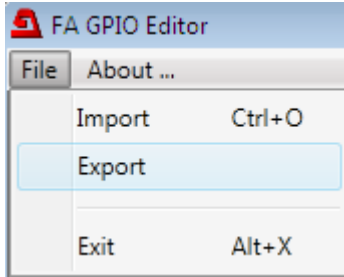

Specify a file name and location to save the settings. The default file name is FA-10DCCRU GPIO.csv. Change the file name, as needed, then click **OK**.

10-2-9. Importing GPI Settings from Files

Select **File > Import** in the menu bar.

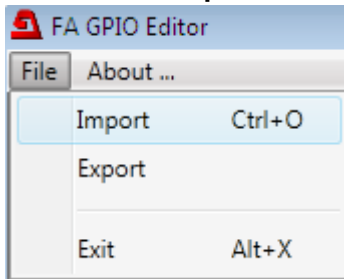

Specify the file name and location.

Verify settings in the FA GPIO Editor, then click **Apply** to send the settings to the FA-10DCCRU unit. (See section 10-2-6. "Sending GPI Settings.")

10-2-10. Verifying GPIO Editor Version

Click **Version Information** in the menu bar.

A window as shown below will appear.

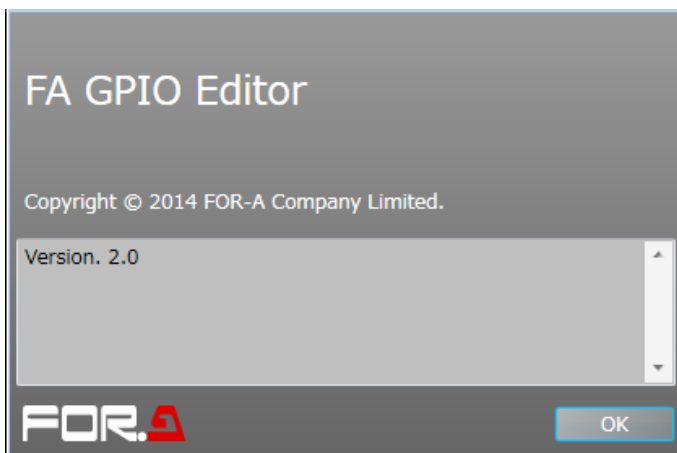

To close the window, click **OK**.

10-3. GPI Pattern List

The following available GPI patterns are mainly for FA-AUX30 use.
Buttons and their functions shown in each pattern represent a button block of FA-AUX30 units.

◆ MU Select

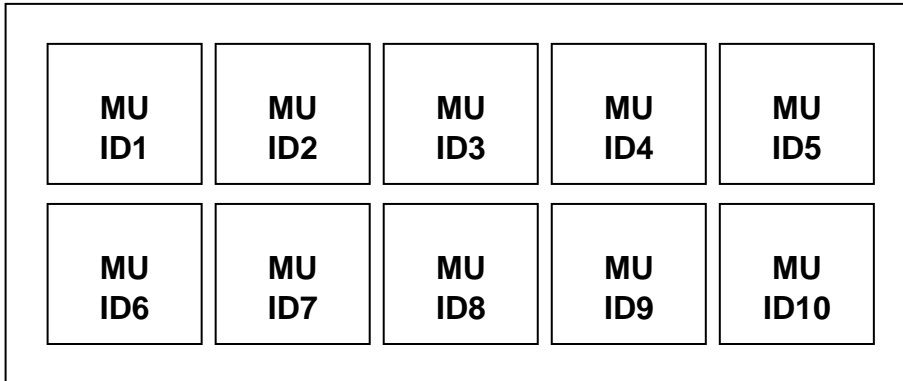

Button function	Description
MU ID1 - 10	Used for MU selection by specifying ID1 – ID10. The LED lights while an MU is connected.

◆ FS Select

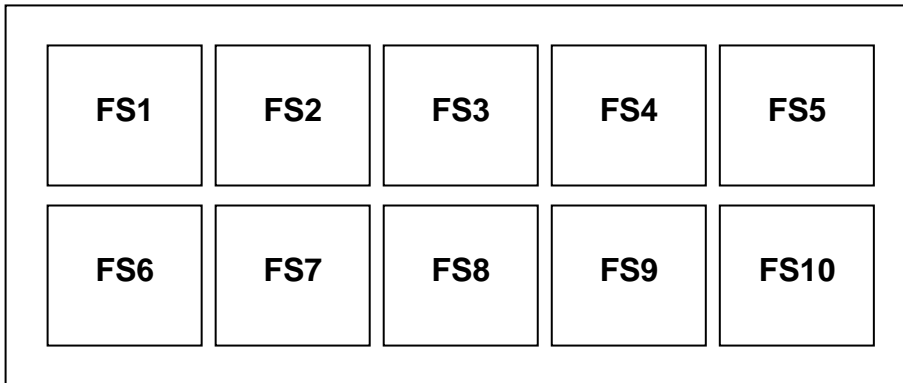

Button function	Description
FS1 - 10	Used for FS selection from FS1 - FS10. The LED lights while an FS is being controlled.

◆ FS Link Select

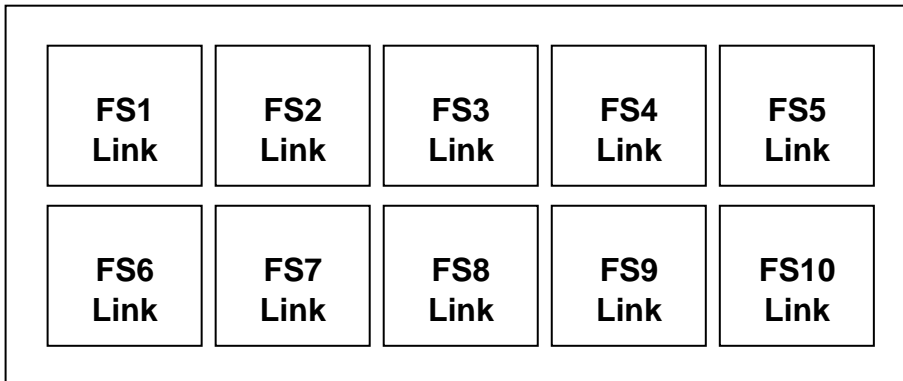

Button function	Description
FS1 – 10 Link	Used to enable FS Link. The LED lights while an FS is linked. When the FS cannot be linked, an error beep sounds.

◆ **FREEZE**

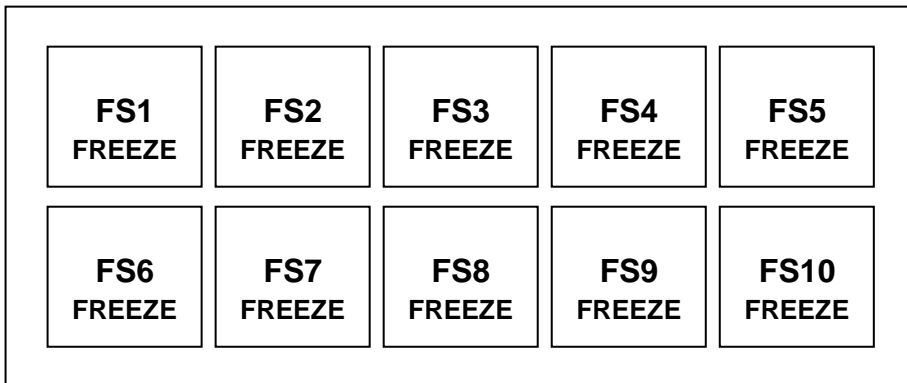

Functions	Description
FS1 – 10 Freeze	Used to set Freeze On/Off on each FS.

◆ **Split**

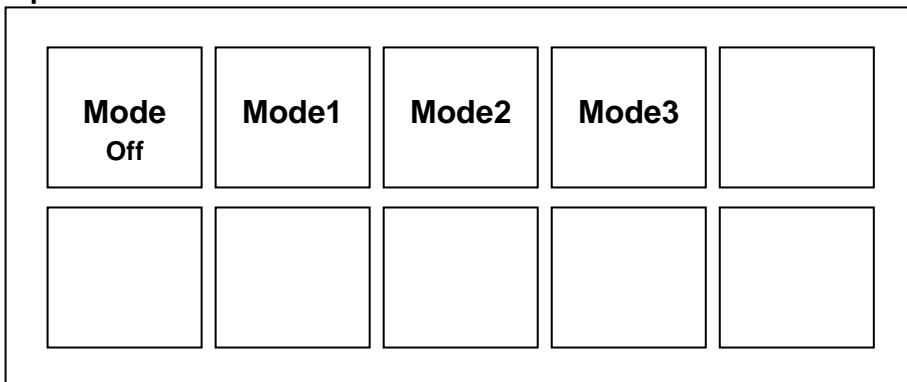

Functions	Description
Mode Off Mode1-3	Used for Split mode selection.

10-4. GPI1-GPI3 Pin Assignments

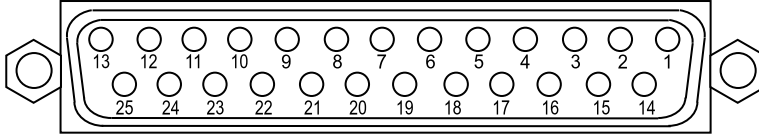

◆ Pin assignments (25-pin D-sub, female)

Pin No.	Signal		
	GPI1	GPI2	GPI3
1	GND (Ground)		
2	GPI OUT 1 (Output)	GPI OUT 11 (Output)	GPI OUT 21 (Output)
3	GPI OUT 2 (Output)	GPI OUT 12 (Output)	GPI OUT 22 (Output)
4	GPI OUT 3 (Output)	GPI OUT 13 (Output)	GPI OUT 23 (Output)
5	GPI OUT 4 (Output)	GPI OUT 14 (Output)	GPI OUT 24 (Output)
6	GPI OUT 5 (Output)	GPI OUT 15 (Output)	GPI OUT 25 (Output)
7	GND (Ground)		
8	GPI IN 1 (Input)	GPI IN 11 (Input)	GPI IN 21 (Input)
9	GPI IN 2 (Input)	GPI IN 12 (Input)	GPI IN 22 (Input)
10	GPI IN 3 (Input)	GPI IN 13 (Input)	GPI IN 23 (Input)
11	GPI IN 4 (Input)	GPI IN 14 (Input)	GPI IN 24 (Input)
12	GPI IN 5 (Input)	GPI IN 15 (Input)	GPI IN 25 (Input)
13	DC OUT (5.0 V output, maximum 200 mA DC)		
14	GPI OUT 6 (Output)	GPI OUT 16 (Output)	GPI OUT2 6 (Output)
15	GPI OUT 7 (Output)	GPI OUT 17 (Output)	GPI OUT2 7 (Output)
16	GPI OUT 8 (Output)	GPI OUT 18 (Output)	GPI OUT 28 (Output)
17	GPI OUT 9 (Output)	GPI OUT 19 (Output)	GPI OUT 29 (Output)
18	GPI OUT 10 (Output)	GPI OUT 20 (Output)	GPI OUT 30 (Output)
19	GND (Ground)		
20	GPI IN 6 (Input)	GPI IN 16 (Input)	GPI IN 26 (Input)
21	GPI IN 7 (Input)	GPI IN 17 (Input)	GPI IN 27 (Input)
22	GPI IN 8 (Input)	GPI IN 18 (Input)	GPI IN 28 (Input)
23	GPI IN 9 (Input)	GPI IN 19 (Input)	GPI IN 29 (Input)
24	GPI IN 10 (Input)	GPI IN 20 (Input)	GPI IN 30 (Input)
25	NC		

10-5. GPI Input Circuit

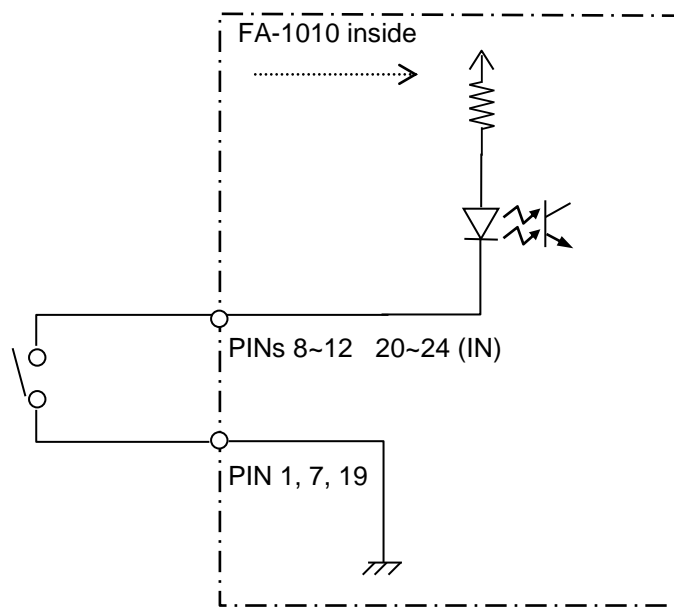

10-6. GPI Input Control

◆ Pulse signals

The pulse signal level change (OPEN to CLOSE) triggers each operation.
OPEN to CLOSE: The assigned function will be turned on.

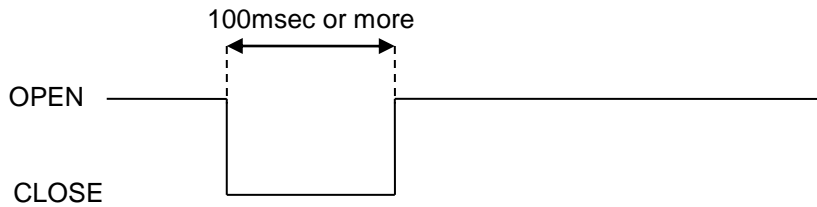

10-7. GPI Output Circuit (Same for GPI 1-3)

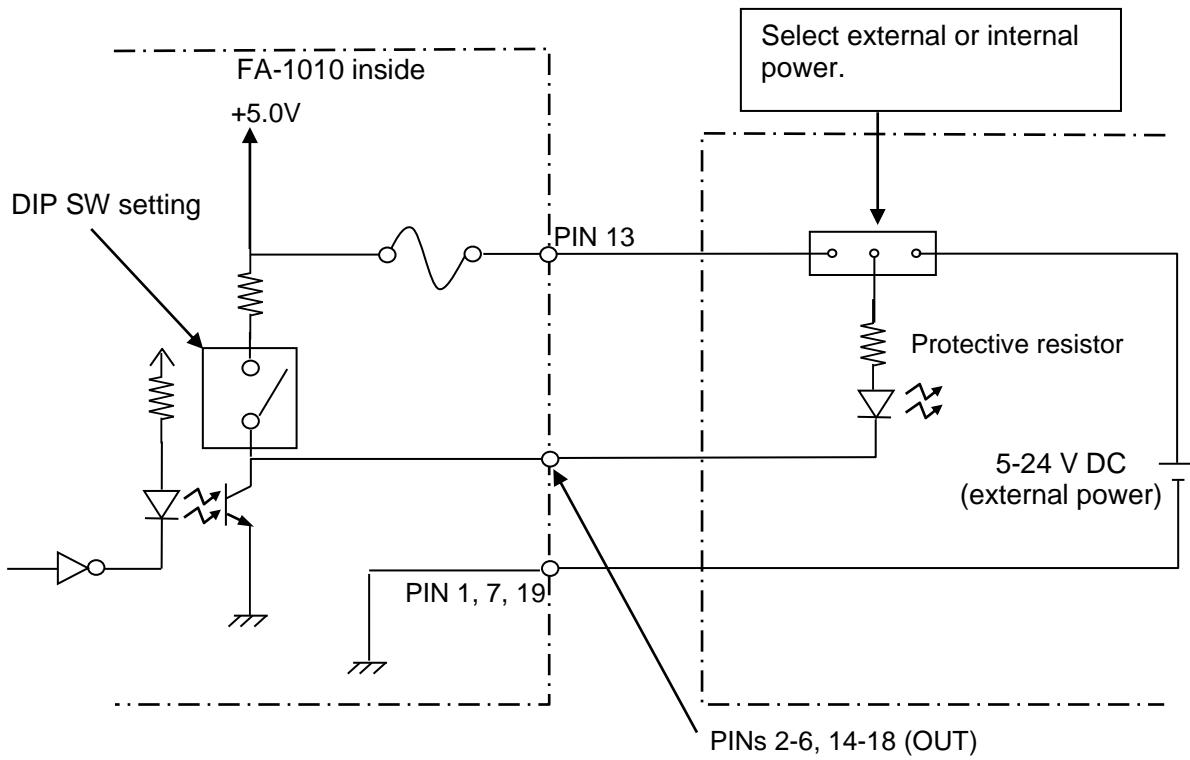

IMPORTANT

Note that the allowed current for each GPI output circuit is **50 mA** and the external power supply should be **5-24 VDC**.

11. FS Link

The FS Link function allows you to simultaneously apply the same settings (Proc Amp, Color Correction and Clip) to all linked FS channels in FA-505, FA-1010 or FA-9520 (FA-9520 mode). This function is available only when FS links are enabled. FS link settings can be performed by GPI inputs sent from an FS-AUX30 or other GPI device/s to the FA-10DCCRU.

11-1. Requirements for FS Link

1. The same Color Correction mode is set in linked FS channels.
2. The same Clip mode is set in linked FS channels.

FS channels cannot be linked if the above two requirements are not met. In addition, Color Correction and Clip modes cannot be changed in FS-linked channels. To change these modes, set FS link to off.

11-2. Notes on FS Link

An FA-10DCCRU always selects and controls an FS when connecting an FA-505, FA-1010 or FA-9520 (FA-9520 mode).

If the FS is not linked, settings are applied only to the FS.

If the FS is linked, settings are applied simultaneously to all linked FS channels.

- * FS links can be set only by GPI inputs sent from GPI devices such as an FA-AUX30.
- * Refer to section 10-2-3. "GPI Input Settings" for details on how to assign the FS Link function to GPI inputs.
- * Refer to section 16-9. "Color Correction" for details on Color Correction mode.
- * Refer to section 6-10. "Clipping Signal Levels" for details on Clip mode.
- * Refer to section 6-3. "Selecting an FS Channel" for details on FS selection.

To prevent unexpected operational errors, assigning "FS Select" functions to GPI inputs is recommended.

11-3. FS Link Examples

Assume that the main unit is FA-1010 and that FS1 - FS10 are set as shown below.

- Color Correction mode is set to **Balance** in FS1 - FS8.
- Clip mode is set to **Off** in FS1 - FS8.
- FS1 - FS5 are **linked On**. FS6 - FS10 are **linked Off**. (See the figure below.)
- Color Correction mode is set to **Differential** in FS9.
- Clip mode is set to **RGB** in FS10.

FS1 Link On	FS2 Link On	FS3 Link On	FS4 Link On	FS5 Link On
FS6 Link Off	FS7 Link Off	FS8 Link Off	FS9 Link Off	FS10 Link Off

In conditions described in the previous page, the following five procedures will change FS states as shown below.

1. If FS1 is selected:
If any value in Proc Amp, Color Correction or Clip is increased or decreased, the difference is applied to all FS channels FS1 – FS5 due to FS link.
Same as above if FS2, FS3, FS4 or FS5 is selected.
Color correction and Clip modes cannot be changed in FS1- FS5, because they are linked.
2. If FS6 is selected:
If any value in Proc Amp, Color Correction or Clip is changed, the new value is applied only to FS6.
Same as above if FS7, FS8, FS9 or FS10 is selected.
3. If setting FS7 link to On (by pressing the FS7 Link button in the previous page):
FS7 link is enabled because Color Correction and Clip modes settings in FS7 are the same as those in FS1-FS5.
The LED indicator of the FS7 Link button turns on.
Same as above for FS6 and FS8.
4. If FS9 Link is set to On (by pressing the FS9 Link button in the previous page):
FS9 linking is **not** enabled because Color Correction and Clip mode settings in FS9 are different from those in FS1-FS5.
A beep sounds and the FS9 link fails.
5. If FS10 Link is set to On (by pressing the FS10 Link button in the previous page):
FS10 linking is **not** enabled because Color Correction and Clip mode settings in FS10 are different from those in FS1-FS5.
A beep sounds and the FS10 link fails.

12. Resetting to Factory Default Settings

To reset FA-10DCCRU to factory settings, power on the FS-10DCCRU by simultaneously pressing **BLACK** and **SEPIA**.

When the reset process starts, the message “Factory Setting” appears on the front panel. Wait for about 10 seconds, power the unit off then on again.

IMPORTANT
Ensure that this operation resets all parameters saved in the FS-10DCCRU to factory default settings.
It is recommended to back up your current data to files before resetting your FA-10DCCRU. (See section 5-3-7. “Backup & Restore.”)

Warning

This equipment has been tested and found to comply with the limits for a Class A digital device, pursuant to Part 15 of FCC Rules. These limits are designed to provide reasonable protection against harmful interference when the equipment is operated in a commercial environment. This equipment generates, uses, and can radiate radio frequency energy and, if not installed and used in accordance with the instruction manual, may cause harmful interference to radio communications. Operation of this equipment in a residential area is likely to cause harmful interference, in which case the user will be required to correct the interference at his own expense.



FOR-A COMPANY LIMITED

Head Office 3-8-1 Ebisu, Shibuya-ku, Tokyo 150-0013, Japan
Overseas Division Tel: +81(0)3 3446 3936 Fax: +81(0)3 3446 1470
Japan Branch Offices Osaka/Okinawa/Fukuoka/Hiroshima/Nagoya/Sendai/Sapporo
R&D/Production Sakura Center/Sapporo Center

FOR-A Corporation of America

11155 Knott Ave., Suite G&H, Cypress, CA 90630, USA.
Tel: +1 714 894 3311 Fax: +1 714 894 5399

FOR-A Corporation of America East Coast Office

2 Executive Drive, Suite 670, Fort Lee Executive Park, Fort Lee, NJ 07024, USA
Tel: +1 201 944 1120 Fax: +1 201 944 1132

FOR-A Corporation of America Distribution & Service Center

2400 N.E. Waldo Road, Gainesville, FL 32609, USA
Tel: +1 352 371 1505 Fax: +1 352 378 5320

FOR-A Corporation of America Miami Office

5200 Blue Lagoon Drive, Suite 760, Miami, FL 33126, USA
Tel: +1 305 931 1700 Fax: +1 305 264 7890

FOR-A Corporation of Canada

1131A, Leslie Street Suite 209, Toronto, Ontario M3C 2J6, Canada
Tel: +1 416 977 0343 Fax: +1 416 977 0657

FOR-A Europe S.r.l.

Via Volturmo 37, 20861 Brugherio MB, Italy
Tel: +39 039 91 64 811 Fax: +39 039 878 140

FOR A UK Limited

Trident Court, 1 Oakcroft Road, Chessington, KT9 1BD, UK
Tel: +44 (0)20 3044 2935 Fax: +44(0)20 3044 2936

FOR-A Italia S.r.l.

Via Volturmo 37, 20861 Brugherio MB, Italy
Tel: +39 039 881 086/103 Fax: +39 039 878 140

FOR-A Corporation of Korea

1007, 57-5, Yangsan-ro, Yeongdeungpo-gu, Seoul 150-103, Korea
Tel: +82 (0)2 2637 0761 Fax: +82 (0)2 2637 0760

FOR-A China Limited

708B Huateng Building, No. 302, 3 District, Jinsong, Chaoyang, Beijing 100021, China
Tel: +86 (0)10 8721 6023 Fax: +86 (0)10 8721 6033

FOR-A Middle East-Africa Office

Dubai Media City, Aurora Tower, Office 1407, P.O. Box 502688, Dubai, UAE
Tel: +971 (0)4 551 5830 Fax: +971 (0)4 551 5832

Agiv (India) Private Limited (FOR-A India)

85, V.N. Purav Marg Sion-Chunabhatti (E) Mumbai - 400 022
Tel: +91 22 2405 1258 Fax: +91 22 2405 0007