

OPERATION – UTILIZAÇÃO FONCTIONNEMENT – FUNCIONAMIENTO



308863

Rev. D

GMax[®] 5900

3300 psi (228 bar, 22.8 MPa) Maximum Working Pressure
Pressão máxima de trabalho de 3300 psi (228 bar, 22,8 MPa)
Pression maximale de service 3300 lb/po² (228 bar, 22.8 MPa)
3300 psi (228 bar, 22,8 MPa) Presión máxima de operación

232624, 232625, 232626
232680, 232681, 232682

All models not available in all countries
Nem todos os modelos existem à disposição em todos os países
Tous les modèles ne sont pas disponibles dans tous les pays
Hay modelos que no se distribuyen en todos los países

Related manuals
Manuais associados
Manuels afférents
Manuales relacionados



..... 308864

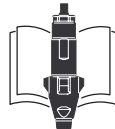

..... 308798









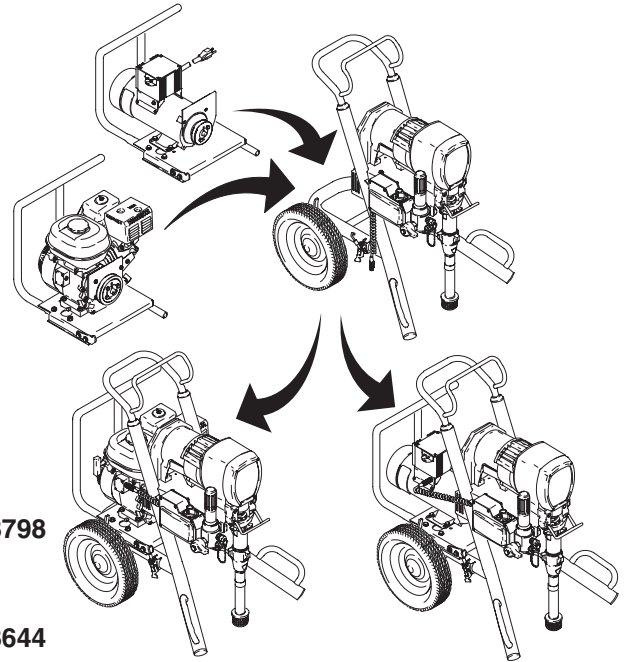

..... 307614



..... 308644



8841A

INSTRUCTIONS	INSTRUÇÕES
<p>READ ALL INSTRUCTION AND WARNINGS BEFORE SETTING UP OR OPERATING THIS UNIT.</p> <p>You need:</p> <ul style="list-style-type: none"> two adjustable wrenches two 5 gallon (20 liters) metal pails Compatible cleaning fluids  Oil Base  Latex	<p>LEIA TODAS AS INSTRUÇÕES E ADVERTÊNCIAS ANTES MONTAR OU UTILIZAR ESTA UNIDADE.</p> <p>Você precisa de:</p> <ul style="list-style-type: none"> Duas chaves inglesas Dois baldes metálicos de 20 litros Líquidos de limpeza compatíveis  À base de óleo  Látex
<p>Matériel requis:</p> <ul style="list-style-type: none"> Deux clés à molette Deux seaux métalliques de 5 gallons (20 litres) Nettoyants liquides compatibles  Émail (base d'huile)  Latex	<p>NECESITA:</p> <ul style="list-style-type: none"> Dos llaves ajustables Dos recipientes metálicos de 20 litros (5 galones) Fluidos de limpieza compatibles  Óleo  Látex
<p>Operating Consideration:</p> <ul style="list-style-type: none"> Always keep sprayer upright while operating or transporting 	<p>Motor acionado por eletricidade: tomada ligada à terra</p> <ul style="list-style-type: none"> 120V, 20A 12 AWG, (1,5 mm²) fio de extensão ligado à terra até 100 M
<p>Power elec. motor: grounded outlet</p> <ul style="list-style-type: none"> 120V, 20A 12 AWG, (1.5 mm²) grounded extension cord up to 300 feet (100 m) 	<p>Motor de potencia eléctrica: toma de corriente puesta a tierra</p> <ul style="list-style-type: none"> 120V, 20A Cordón de extensión con tierra de 12 AWG (1.5 mm²) de hasta 100 metros (300 pies)

⚠ WARNING

Fire and explosion can occur when spraying or flushing flammable fluid in an area where air circulation is poor and flammable vapors can be ignited by an open flame or sparks.

To help prevent a fire and explosion:

- Use outdoors or in an extremely well ventilated area.
- Do not use 1,1,1-trichloroethane, methylene chloride, other halogenated hydrocarbon solvents or fluids containing such solvents in pressurized aluminum equipment. Such use could result in a chemical reaction, with the possibility of explosion.
- Remove, extinguish or unplug all ignition sources; tape wall switch. Do not smoke in spray area.
- Never fill fuel tank while the engine is running or hot.
- Ground Sprayer, object being sprayed, paint and solvent pails.
- Hold gun firmly to side of a grounded pail when triggering into pail.
- Use only conductive airless paint hose.
- Never run engine in inclosed area.



Fluid injection is a serious injury! If high pressure fluid pierces your skin, the injury might look like "just a cut". But it is a serious wound! Get immediate medical attention.

To help prevent injection, always:

- Engage trigger safety latch when not spraying.
- Point gun away from yourself or anyone else.
- Relieve pressure before checking or repairing any leak.
- Relieve pressure when you turn off the sprayer or stop spraying.
- Do not use components rated less than system *Maximum Working Pressure*

Never allow children to use this unit. If you are injured using this equipment, get immediate medical treatment.



⚠ ADVERTÊNCIA

Poderá ocorrer **incêndio e explosão** quando for pulverizado ou injetado líquido inflamável numa área onde houver má circulação de ar; vapores inflamáveis poderão incendiar-se a partir de uma chama ou faúlhas a descoberto.

Para ajudar a evitar incêndio e explosão:

- **Utilize no exterior ou numa área muito bem ventilada.**
- Não utilize 1,1,1-tricloroetano, cloreto de metileno, outros solventes de hidrocarbonetos halogenados ou líquidos contendo tais solventes em equipamento de alumínio pressurizado. Tal utilização poderá resultar numa reação química, com possibilidade de explosão.
- Retire, elimine ou desligue todas as fontes de ignição; coloque fita adesiva na tomada da parede. Não fume na área de pulverização.
- Nunca abasteça o depósito de combustível com o motor em funcionamento ou quente.
- Ponha em contato com a terra o pulverizador, o objeto a ser pulverizado, e os baldes de tinta e de solventes.
- Segure a pistola firmemente de encontro ao lado de um balde em contato com a terra, quando estiver descarregando para dentro do mesmo.
- Utilize somente tubos flexíveis condutores para pintura a alta pressão.
- Nunca faça funcionar o motor numa área fechada.

A injeção de líquido é um ferimento grave! Se o líquido a alta pressão penetrar na sua pele, o ferimento poderá parecer "simplesmente um corte". Mas é um ferimento grave! Procure o médico imediatamente.

Para ajudar a evitar injeção de líquido, faça sempre o seguinte:

- Engate o trinco de segurança do gatilho quando não estiver pulverizando.
- Sempre aponte a pistola para longe de você mesmo(a) ou de outras pessoas.
- Alivie a pressão antes de verificar ou reparar qualquer vazamento.
- Alivie a pressão quando desligar o pulverizador ou parar de pulverizar.
- Não utilize componentes classificados para uma pressão nominal inferior à pressão máxima de trabalho dos sistemas.

Nunca permita que crianças utilizem esta unidade. Se sofrer algum ferimento durante a utilização deste equipamento, procure o médico imediatamente.

⚠ MISE EN GARDE

Risque d'incendie et d'explosion imminent pendant la pulvérisation ou le rinçage à pression de fluides inflammables dans une zone à mauvaise circulation d'air et en présence de gaz inflammables pouvant s'allumer par une flamme nue ou des étincelles.

Pour éviter les risques d'incendie et d'explosion:

- **Manipuler les fluides à l'air libre ou dans une zone extrêmement bien aérée.**
- Ne jamais utiliser de trichloroéthane 1,1,1, de chlorure de méthylène, d'autres solvants à base d'hydrocarbures halogénés, ni de produits contenant de tels solvants dans un équipement sous pression en aluminium. Cela pourrait provoquer une réaction chimique avec risque d'explosion.
- Retirer, éteindre ou déboucher toute source d'inflammation, recouvrir tout interrupteur mural avec du ruban adhésif. Ne pas fumer dans la zone de pulvérisation.
- Ne jamais remplir le réservoir d'essence lorsque le moteur est chaud ou en marche.
- Mettre à la terre le pulvérisateur, l'objet à pulvériser ainsi que les seaux de peinture et de solvants.
- Tenir le pistolet fermement contre la paroi d'un seau mis à la terre lorsqu'on pulvérise dans le seau.
- N'utiliser qu'un flexible pour peinture pulvérisée sans air.
- Ne jamais mettre en marche un moteur dans une zone fermée.



⚠ ADVERTENCIA

Pueden ocurrir **incendios y explosiones** cuando se pulveriza fluido inflamable o cuando se lava con este tipo de fluido en un área donde la circulación de aire es deficiente y los vapores inflamables se pueden encender al contacto con el fuego o chispas.

Para prevenir incendios y explosiones:

- **Use en espacios abiertos o en un área muy bien ventilada.**
- No utilice nunca tricloroetano-1,1,1, cloruro de metileno, u otros disolventes a base de hidrocarburos halógenos o fluidos que contengan tales disolventes en un equipo a presión de aluminio. El uso de estas sustancias puede provocar una intensa reacción química, con riesgos de explosión.
- Retire, apague o desconecte todas las fuentes de ignición; asegure el interruptor de la pared con cinta. No fume en el área de pulverización.
- Nunca llene el estanque de combustible mientras el motor esté en marcha o caliente.
- Ponga a tierra el pulverizador, el objeto que recibe el chorro pulverizado, las cubetas de pintura y disolvente.
- Sostenga firmemente la pistola a un lado de la cubeta puesta a tierra cuando dispare dentro de ella.
- Use solamente mangueras para pintura conductora sin aire.
- Nunca haga andar el motor dentro de un área cerrada.

¡La inyección de fluido en la piel es una lesión seria! Si fluido de alta presión le penetra la piel, la lesión podría parecer "sólo un corte". ¡Es una lesión seria! Consulte de inmediato al médico.

Para prevenir la inyección en la piel, siempre:

- Enganche el seguro del gatillo cuando no use el pulverizador.
- No apunte la pistola ni a sí mismo ni a los demás.
- Alivie la presión antes de inspeccionar o reparar cualquier filtración.
- Alivie la presión cuando apague el pulverizador o deje de usarlo.
- No use componentes cuya capacidad nominal sea inferior a la presión máxima de operación del sistema.

No permita que niños usen esta unidad. Si se lesiona usando este equipo, sométase de inmediato a tratamiento médico.

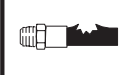

CONTROLS / CONTROLES / COMMANDES / CONTROLES

On/Off Switch
 Interruptor de ligar e desligar
 Interrupteur marche/arrêt
 Interruptor de encendido/apagado



On/Off Switch Aan/Uit Schakelaar
 Interrupteur Marche/Arrêt
 Ein-Aus-Schalter

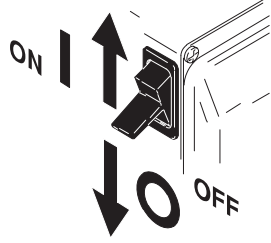

Pressure Control
 Controle da pressão
 Système de contrôle de la pression
 Dispositivo de control de la presión

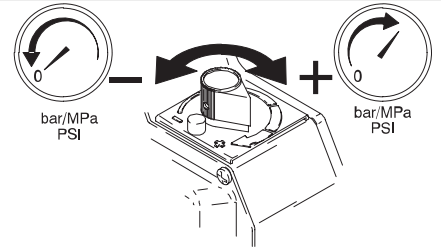

Engine Controls
 Controles do motor
 Commandes de moteur
 Controles del motor

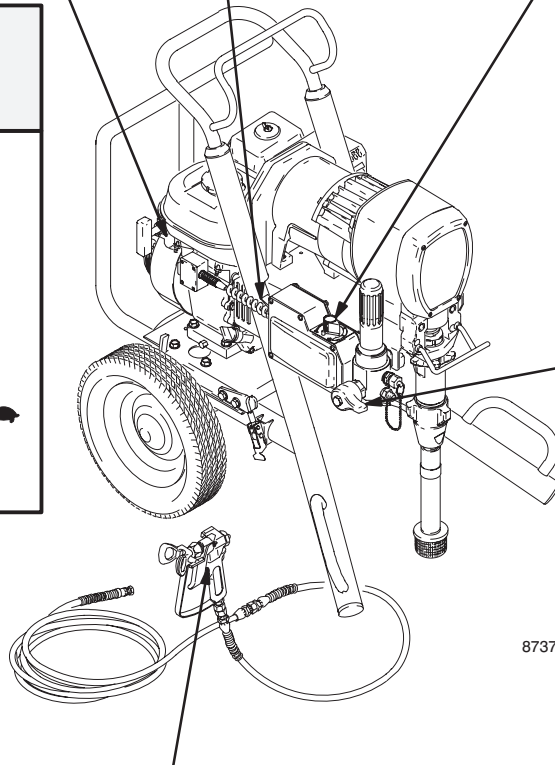
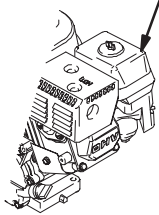
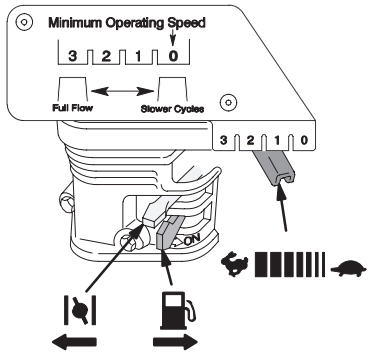

8737A

Drain Valve
 Válvula de drenagem
 Vidange
 Válvula de vaciado

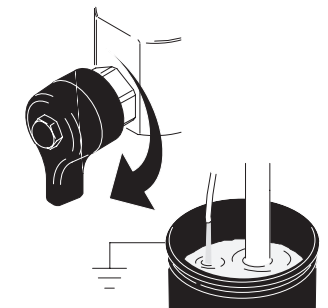
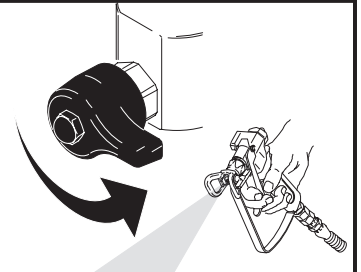

Trigger Lock
 Fecho do gatilho
 Loquet de sécurité
 Seguro del gatillo

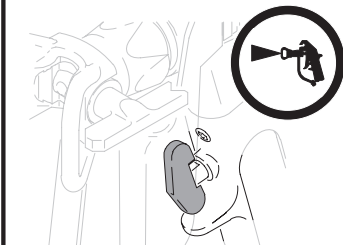

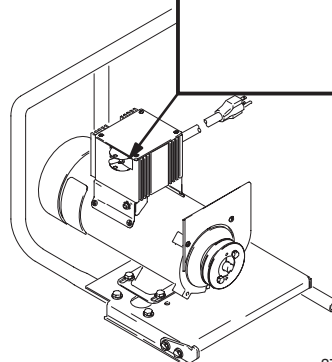
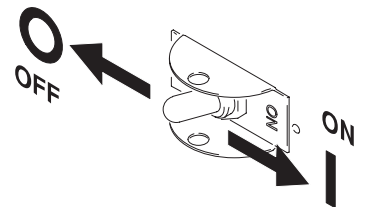

On/Off Switch
 Interruptor de ligar e desligar
 Interrupteur marche/arrêt
 Interruptor de encendido/apagado



8746A

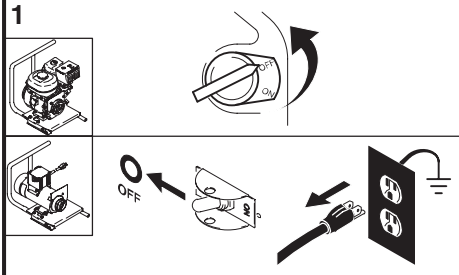
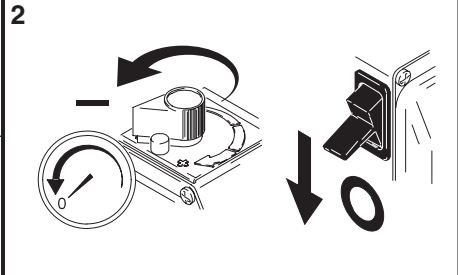
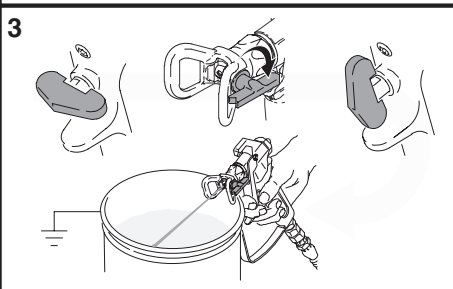

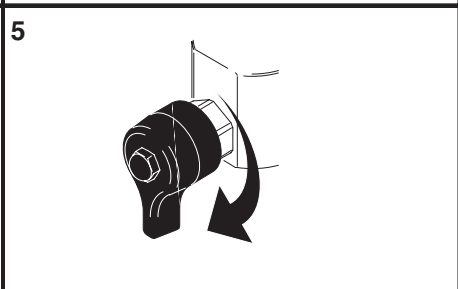
PRESSURE RELIEF / ALÍVIO DE PRESSÃO / DÉCHARGE DE PRESSION / ALIVIO DE LA PRESIÓN 1→5

 <p>Follow 1-5 when you stop spraying. Siga os passos de 1-5 quando parar de pulverizar.</p> <p>Suivre les étapes 1 à 5 lorsqu'on arrête de pulvériser.</p> <p>Siga los pasos 1-5 cuando deje de usar el pulverizador.</p>	<p>1</p> 	<p>2</p> 
<p>3</p> 	<p>4</p> 	<p>5</p> 

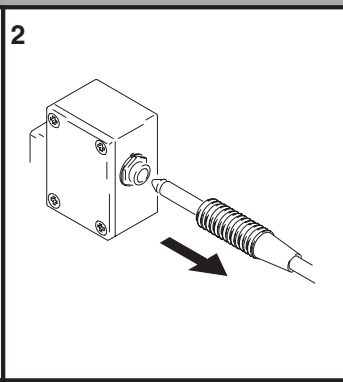
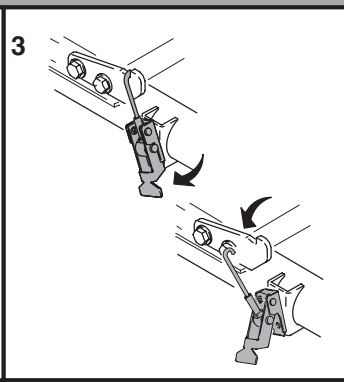
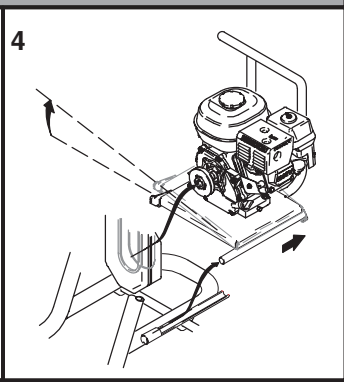
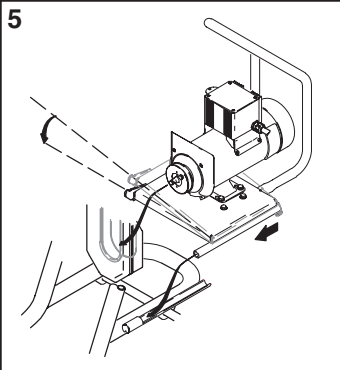
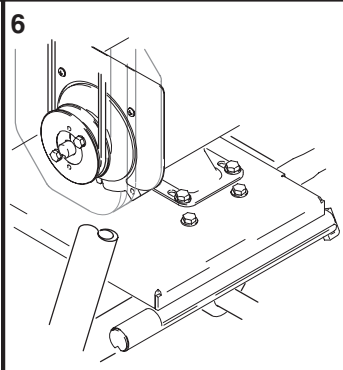
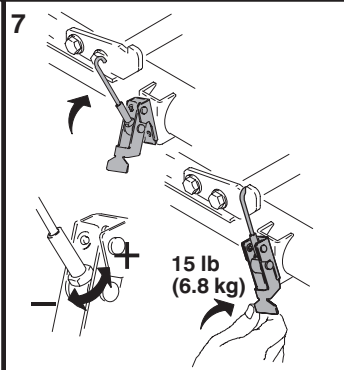
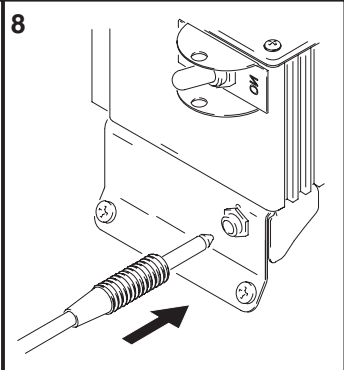
CHANGE ENGINE TO MOTOR / MUDANÇA DO MECANISMO DO MOTOR / PASSAGE DU MOTEUR ESSENCE À MOTEUR ÉLECTRIQUE / CAMBIO DE UN MOTOR A OTRO 1→8

<p>1</p>  <p>Pressure Relief Alívio de pressão Décharge de pression Alivio de la presión</p>	<p>2</p> 	<p>3</p> 	<p>4</p> 
<p>5</p> 	<p>6</p> 	<p>7</p>  <p>15 lb (6.8 kg)</p>	<p>8</p> 

STARTUP / PARTIDA / DÉMARRAGE / PUESTA EN MARCHA 1→24

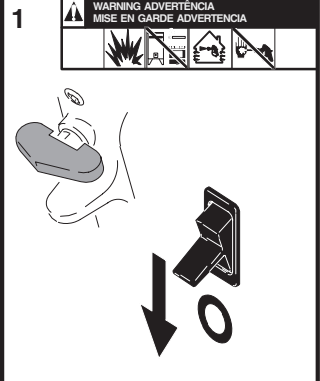
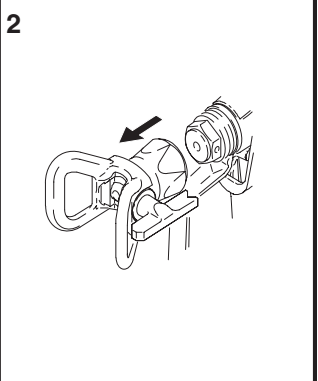
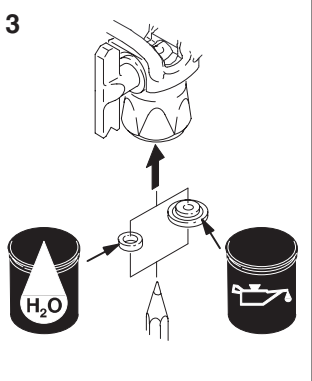
<p>Flush with warm soapy water. Faça a descarga com água morna e sabão dissolvido. Rincer avec de l'eau tiède savonneuse. Enjuague con agua tibia con jabón.</p>  <p>Flush with mineral spirits. Faça a descarga com álcool mineral. Rincer avec une esence minérale. Enjuague con alcohol mineral.</p> 	<p>1</p>  <p><small>WARNING ADVERTENCIA MISE EN GARDE ADVERTENCIA</small></p>	<p>2</p> 	<p>3</p> 
--	---	--	---

Start Engine / Partida do motor / Démarrage / Partida del motor 4→11

<p>4</p> <p>WARNING ADVERTENCIA MISE EN GARDE ADVERTENCIA</p>	<p>5</p>	<p>6</p>	<p>7</p>
<p>8</p> <p>Minimum Operating Speed</p> <p>Full Flow ← Stower Cycles</p>	<p>9</p> <p>Cold Engine Starts Partida do motor a frio Démarrages à froid Partida del motor en frío</p>	<p>10</p>	<p>11</p>

Flush / Descarga / Vidange / Enjuague 12→19

<p>12</p> <p>WARNING ADVERTENCIA MISE EN GARDE ADVERTENCIA</p> <p>WASTE RESÍDUOS À JETER DESECHO FLUSH DESCARGA VIDANGE ENJUAGUE</p>	<p>13</p> <p>Start Engine Partida do motor Démarrage Partida del motor</p>	<p>14</p> <p>+ 1/2</p>	<p>15</p> <p>FLUSH DESCARGA VIDANGE ENJUAGUE</p>
<p>16</p> <p>20 SEC.</p> <p>WASTE RESÍDUOS À JETER DESECHO</p>	<p>17</p> <p>1 MIN.</p> <p>FLUSH DESCARGA VIDANGE ENJUAGUE</p>	<p>18</p> <p>10 SEC.</p> <p>FLUSH DESCARGA VIDANGE ENJUAGUE</p>	<p>19</p>

Prime / Preparação / Amórçage / Cebado 20→23

<p>20</p> <p>WARNING ADVERTENCIA MISE EN GARDE ADVERTENCIA</p> <p>WASTE RESÍDUOS À JETER DESECHO PAINT TINTA PEINTURE PINTURA</p>	<p>21</p> <p>Watch for paint Cuidado com a tinta Vérifier l'arrivée de la peinture Observe cuando salga pintura</p>	<p>22</p> <p>PAINT TINTA PEINTURE PINTURA</p>	<p>23</p> <p>Watch for paint Cuidado com a tinta Vérifier l'arrivée de la peinture Observe cuando salga pintura</p>
---	---	---	---

SPRAY / PULVERIZAÇÃO / PULVÉRISATION / PULVERISACIÓN 1→4

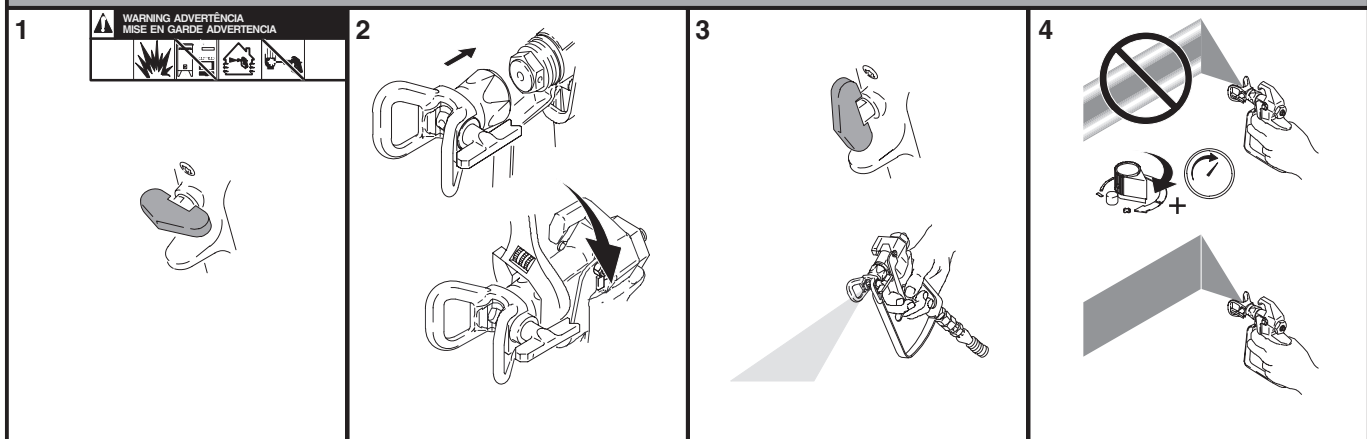



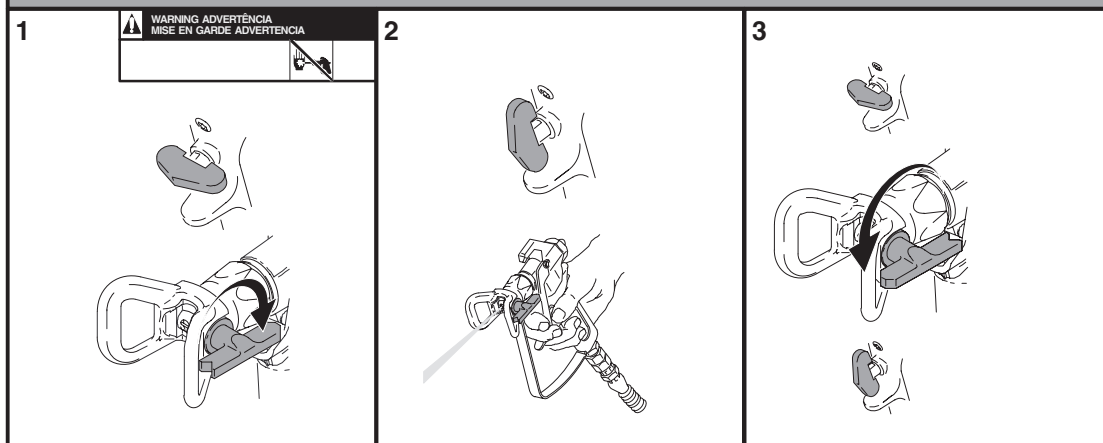



CLEAR CLOG / DESOBSTRUÇÃO / DÉCRASSEMENT / DESTAPAR

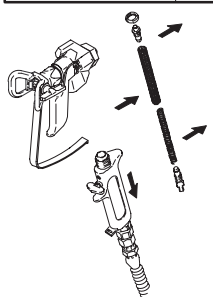
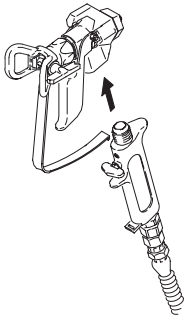
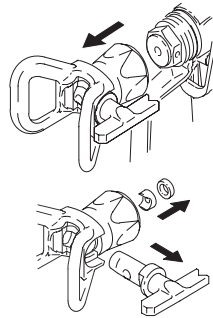
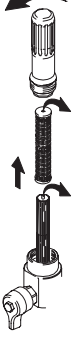
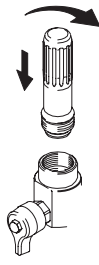

CHANGE PAINT / TROCA DE TINTA / CHANGEMENT DE PEINTURE / CAMBIAR PINTURA

<p>1</p> <p>Pressure Relief Alívio de pressão Décharge de pression Alivio de la presión</p>	<p>2</p> <p>Flush Descarga Vidange Enguaje</p>	<p>3</p> <p>Prime Preparação Amorçage Cebado</p>
--	---	---

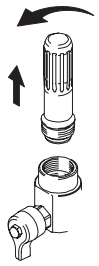
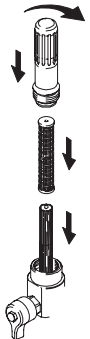
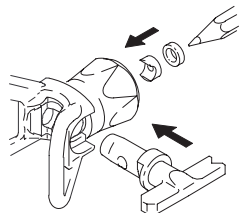
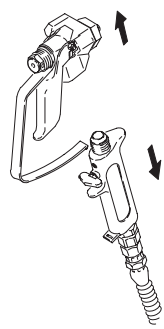
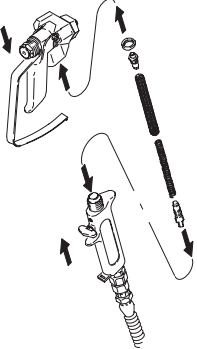
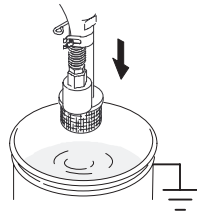
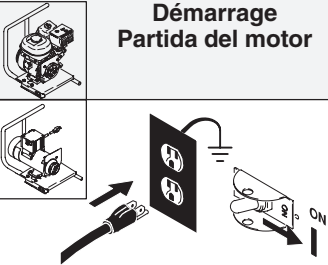
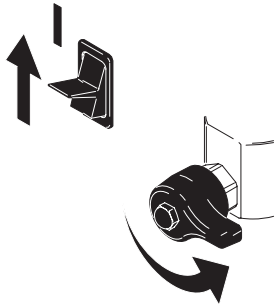
SHUTDOWN / DESATIVAÇÃO / ARRÊT / PARADA

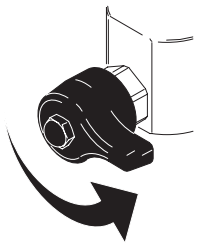
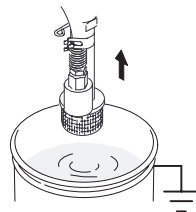
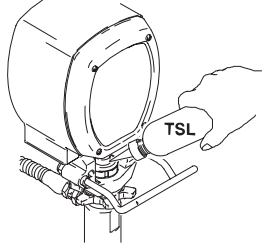
<p>1</p>  <p>MPa/bar/PSI</p> <p>Pressure Relief Alívio de pressão Décharge de pression Alivio de la presión</p>	<p>2</p> <p>WARNING ADVERTÊNCIA MISE EN GARDE ADVERTENCIA</p> 	<p>3</p> 	<p>4</p> 	<p>5</p> 
<p>6</p> 	<p>7</p> <p>Flush Descarga Vidange Enguaje</p>	<p>8</p>  <p>20 SEC.</p> <p>FLUSH DESCARGA VIDANGE ENJUAGUE</p>	<p>9</p>  <p>MPa/bar/PSI</p> <p>Pressure Relief Alívio de pressão Décharge de pression Alivio de la presión</p>	<p>10</p>  <p>FLUSH DESCARGA VIDANGE ENJUAGUE</p>
<p>11</p> 	<p>12</p> 	<p>13</p> 	<p>14</p> 	<p>15</p> 
<p>16</p>  <p>Mineral Spirits Álcool mineral Essence minérale Alcohol mineral</p>	<p>17</p> <p>Start Engine Partida do motor Démarrage Partida del motor</p> 	<p>18</p> 	<p>19</p>  <p>20 SEC.</p> <p>WASTE RESIDUOS A JETER DESECHO</p>	
<p>20</p>  <p>MPa/bar/PSI</p> <p>Pressure Relief Alívio de pressão Décharge de pression Alivio de la presión</p>	<p>21</p> 	<p>22</p>  <p>Mineral Spirits Álcool mineral Essence minérale Alcohol mineral</p>	<p>23</p>  <p>TSL</p>	

Graco Standard Warranty Garantia Standard da Graco Garantie standard de Graco Garantía estándar Graco

Graco warrants all equipment referenced in this document which is manufactured by Graco and bearing its name to be free from defects in material and workmanship on the date of sale by an authorized Graco distributor to the original purchaser for use. With the exception of any special, extended, or limited warranty published by Graco, Graco will, for a period of twelve months from the date of sale, repair or replace any part of the equipment determined by Graco to be defective. This warranty applies only when the equipment is installed, operated and maintained in accordance with Graco's written recommendations.

This warranty does not cover, and Graco shall not be liable for general wear and tear, or any malfunction, damage or wear caused by faulty installation, misapplication, abrasion, corrosion, inadequate or improper maintenance, negligence, accident, tampering, or substitution of non-Graco component parts. Nor shall Graco be liable for malfunction, damage or wear caused by the incompatibility of Graco equipment with structures, accessories, equipment or materials not supplied by Graco, or the improper design, manufacture, installation, operation or maintenance of structures, accessories, equipment or materials not supplied by Graco.

This warranty is conditioned upon the prepaid return of the equipment claimed to be defective to an authorized Graco distributor for verification of the claimed defect. If the claimed defect is verified, Graco will repair or replace free of charge any defective parts. The equipment will be returned to the original purchaser transportation prepaid. If inspection of the equipment does not disclose any defect in material or workmanship, repairs will be made at a reasonable charge, which charges may include the costs of parts, labor, and transportation.

THIS WARRANTY IS EXCLUSIVE, AND IS IN LIEU OF ANY OTHER WARRANTIES, EXPRESS OR IMPLIED, INCLUDING BUT NOT LIMITED TO WARRANTY OF MERCHANTABILITY OR WARRANTY OF FITNESS FOR A PARTICULAR PURPOSE.

Graco's sole obligation and buyer's sole remedy for any breach of warranty shall be as set forth above. The buyer agrees that no other remedy (including, but not limited to, incidental or consequential damages for lost profits, lost sales, injury to person or property, or any other incidental or consequential loss) shall be available. Any action for breach of warranty must be brought within two (2) years of the date of sale.

GRACO MAKES NO WARRANTY, AND DISCLAIMS ALL IMPLIED WARRANTIES OF MERCHANTABILITY AND FITNESS FOR A PARTICULAR PURPOSE, IN CONNECTION WITH ACCESSORIES, EQUIPMENT, MATERIALS OR COMPONENTS SOLD BUT NOT MANUFACTURED BY GRACO. These items sold, but not manufactured by Graco (such as electric motors, switches, hose, etc.), are subject to the warranty, if any, of their manufacturer. Graco will provide purchaser with reasonable assistance in making any claim for breach of these warranties.

In no event will Graco be liable for indirect, incidental, special or consequential damages resulting from Graco supplying equipment hereunder, or the furnishing, performance, or use of any products or other goods sold hereto, whether due to a breach of contract, breach of warranty, the negligence of Graco, or otherwise.

PARA CLIENTES BRASILEIROS DA GRACO

As partes confirmam que solicitaram que o presente documento, assim como todos os demais documentos, notas e processos legais inseridos, atribuídos ou instituídos de acordo com o mesmo ou relacionados direta ou indiretamente com o este documento, sejam redigidos em inglês.

AUX CLIENTS DE GRACO AU CANADA

Les parties conviennent avoir demandé que le présent document, ainsi que tout autre document, avis et procédures judiciaires inclus, donnés dans les présentes ou institués en vertu des présentes, ou en relation directe ou indirecte aux présentes, soient rédigés en anglais.

PARA CLIENTES DE GRACO EN COLOMBIA

Las partes reconocen que han solicitado que el presente documento, como asimismo todos los documentos, notificaciones y compromisos legales que se suscriban, presentados o instituidos por el presente o relacionados directa e indirectamente con éste, sean redactados en inglés.

ADDITIONAL WARRANTY COVERAGE / COBERTURA DE GARANTIA ADICIONAL / GARANTIE PROLONGÉE / COBERTURA ADICIONAL DE LA GARANTÍA /

Graco does provide extended warranty and wear warranty for products described in the "Graco Contractor Equipment Warranty Program". A Graco fornece prorrogação de garantia e garantia de desgaste para os produtos descritos no "Graco Contractor Equipment Warranty Program" (Programa de garantia de equipamento do empreiteiro da Graco). Graco n'offre pas de garantie prolongée ni de garantie contre l'usure pour les produits décrits dans le "Programme de garantie des équipements pour entrepreneur de Graco". Graco ofrece una garantía extendida y una garantía de desgaste para los productos consignados en el "Programa de Garantía de Equipo Graco para Contratistas".

TO PLACE AN ORDER OR FOR SERVICE, contact your Graco distributor.

PARA EFETUAR ENCOMENDAS OU PARA ASSISTÊNCIA TÉCNICA, contate o seu distribuidor da Graco.

POUR PLACER UNE COMMANDE OU DEMANDER DU SERVICE, contactez votre distributeur Graco.

PARA REMITIR UN PEDIDO O SOLICITAR SERVICIO, póngase en contacto con el distribuidor de Graco.

All written and visual data contained in this document reflects the latest product information available at the time of publication. Graco reserves the right to make changes at any time without notice.

Todos os dados escritos e visuais contidos neste documento refletem as mais recentes informações sobre o produto disponíveis na época da publicação. A Graco reserva-se o direito de efetuar alterações em qualquer momento sem aviso prévio.

Toute information écrite et graphique incluse dans ce document reflète les caractéristiques les plus récentes des produits au moment d'aller sous presse. Graco se réserve le droit d'apporter des modifications en tout temps sans avis.

Toda la información escrita y visual contenida en este documento refleja la información de producto más reciente manejada al momento de la publicación. Graco se reserva el derecho de introducir cambios en cualquier momento sin aviso.

Sales Offices: Minneapolis, Detroit
Foreign Offices: Belgium, Korea, Hong Kong, Japan
Escritórios de Vendas: Minneapolis, Detroit
Escritórios estrangeiros: Bélgica, Coréia, Hong Kong, Japão
Bureaux des ventes: Minneapolis, Detroit
International: Belgique, Corée, Hong Kong, Japon
Oficina de ventas: Minneapolis, Detroit
Oficinas internacionales: Bélgica, Corea, Hong Kong, Japón

GRACO INC. P.O. BOX 1441 MINNEAPOLIS, MN 55440-1441

<http://www.graco.com>

PRINTED IN USA 308863 January 1998, Revised August 1999