

USER'S MANUAL
Rev. 01/2007

CD3200 THYRISTOR UNIT

from 125A to 700A



CD Automation S.r.l.

Via Picasso 34/36 - 20025 - Legnano (MI) - ITALY

Tel +39 0331 577479 - Fax +39 0331 579479

E-Mail: info@cdautomation.com - WEB: www.cdautomation.com

SUMMARY

1 Important warnings for safety	5
2 Introduction	7
2.1 Advantages compared with analog thyristor unit	7
2.2 CD-KP	8
2.3 CD-EASY	8
2.4 Software Configurator	9
3 Quick Start	10
4 CD3200 Sizing	10
5 Identification and Order Code	11
5.1 Identification of the unit	11
5.2 Order Code	12
6 Installation	13
6.1 Environmental installation conditions	13
6.2 Dimensions and Weight	14
6.3 Fixing holes	15
7 Wiring instructions	16
7.1 Removing the cover	16
7.2 Wiring details	17
7.3 Power Terminals	19
7.4 Command Terminals	20
7.5 Diagram of control connection	21
8 Power output features	22
8.1 Derating curve	22
8.2 Cooling fans	22
9 Led status and Alarms	23
9.1 LED Status Table	23
9.2 Not Critical Alarm	23
9.3 Calibration Procedure	24
10 Firing type	24
10.1 Phase Angle (PA)	25
10.2 Soft Start with Phase Angle (S+PA)	25
10.3 Action of the Limit Current	26
10.4 Feed-back type	27

11 Connection description	28
11.1 Access to the Electronic boards	28
11.2 Supply the Electronic Board	29
11.3 Analog Inputs	30
11.4 Digital Input	33
11.5 Digital Output	34
11.6 PG Connector	34
11.7 RS485 Serial Port	35
11.8 Address configuration	36
12 MODBUS communication	37
12.1 MODBUS RTU Protocol	37
12.2 Message Format	37
12.3 Read Holding Registers	39
12.4 Preset Multiple Registers	39
12.5 Error and exception responses	40
13 Configuration Parameters	41
14 Internal Fuse	44
14.1 Fuse Code	44
15 Maintenance	45
15.1 Trouble Shooting	45
15.2 Fans	46
15.3 Maintenance	46
15.4 Repairing procedure	46
15.5 Warranty condition	46

1 Important warnings for safety

This chapter contains important information for the safety. The not observance of these instructions may result in serious personal injury or death and can cause serious damages to the Thyristor unit and to the components system included.

The installation should be performed by qualified persons.



The Thyristor unit are integral part of industrial equipments. When it is supply, the Thyristor unit is subject to dangerous tensions.

- Don't remove the protection Cover.
- Don't use these unit in aerospace applications and/ or nuclear.



The nominal current corresponds to use at temperature not superior to 45°C.

- The Thyristor unit must be mounted in vertical position and without obstruction above and below to allow a good flow ventilation.
- The hot air of one thyristor unit must not invest the unit positioned above.
- For side by side placed leave a space of 15mm between the unit.



A suitable device must ensure that the unit can be electrically isolated from the supply, this allows the qualified people to work in safety.



Protection (Protection, Protezione)

The unit have IP20 protection rating as defined by the specific international. Is necessary consider the place of installation.



Earth (Terre, Messa a terra)

For safety, the Thyristor unit with isolated heat-sink must be connected to earth. Earth impedance should be correspondent to local earth regulation. Periodically the earth efficiency should be inspected.



Electronic supply (Alimentation électronique, Alimentazione elettronica)

The electronic circuit of the Thyristor unit must be supplied by dedicated voltage for all electronic circuits and not in parallel with coil contactors, solenoids and other.

It's recommended to use a shielded transformer.



Electric Shock Hazard (Risque de choque électrique, Rischi di scosse elettriche)

When the Thyristor unit is energized, after the power supply is shut off, wait least a minute for allow the discharge of the internal capacitors where there is a dangerous tension. Before working, make sure that:

- Only authorized personnel must perform maintenance, inspection, and replacement operations.
- The authorized personnel must read this manual before to have access to the unit.
- Unqualified People don't perform jobs on the same unit or in the immediate vicinities.

**Important warnings (Attention, Avvertenze importanti)**

During the operations with units under tension, local regulations regarding electrical installation should be rigidly observed:

- Respect the internal safety rules.
- Don't bend components to maintain insulation distances.
- Protect the units from high temperature humidity and vibrations.
- Don't touch components to prevent electrostatic discharges on them.
- Verify that the size is in line with real needs.
- To measure voltage current etc. on unit, remove rings and other jewels from fingers and hands.
- Authorized personnel that work on thyristor unit under power supply voltage must be on insulated board

This listing does not represent a complete enumeration of all necessary safety cautions.

**Electromagnetic compatibility****(Compatibilità elettromagnétique, Compatibilità elettromagnetica)**

Our thyristor units have an excellent immunity to electromagnetic interferences if all suggestions contained in this manual are respected. In respect to a good Engineering practice, all inductive loads like solenoids contactor coils should have a filter in parallel.

**Emissions (Emission, Emissioni)**

All solid-state power controllers emit a certain amount of radio-frequency energy because of the fast switching of the power devices.

The CD Automation's Thyristor unit are in accord with the EMC norms, CE mark.

In most installations, near by electronic systems will experience no difficulty with interference. If very sensitive electronic measuring equipment or low-frequency radio receivers are to be used near the unit, some special precautions may be required. These may include the installation of a line supply filter and the use of screened (shielded) output cable to the load.

Note

Warning: This icon is present in all the operational procedures where the Improper operation may result in serious personal injury or death



Caution: This icon is present in all the operational procedures where the Improper operation can cause damage for the Thyristor unit.

CD Automation reserves the right to modify the own products and this manual without any advise.



2 Introduction

A thyristor unit is semiconductor device which acts as a switch formed by two thyristors in ant parallel. To switch on the alternating current the input signal will be on and the thyristor will switch off at first Zero Crossing voltage with no input signal.

The benefits of thyristor units compared with electromechanical contactors are numerous: no moving parts, no maintenance and capacity to switch very fast. Thyristors are the only solution to control transformers and special loads that change resistance with temperature and with age.

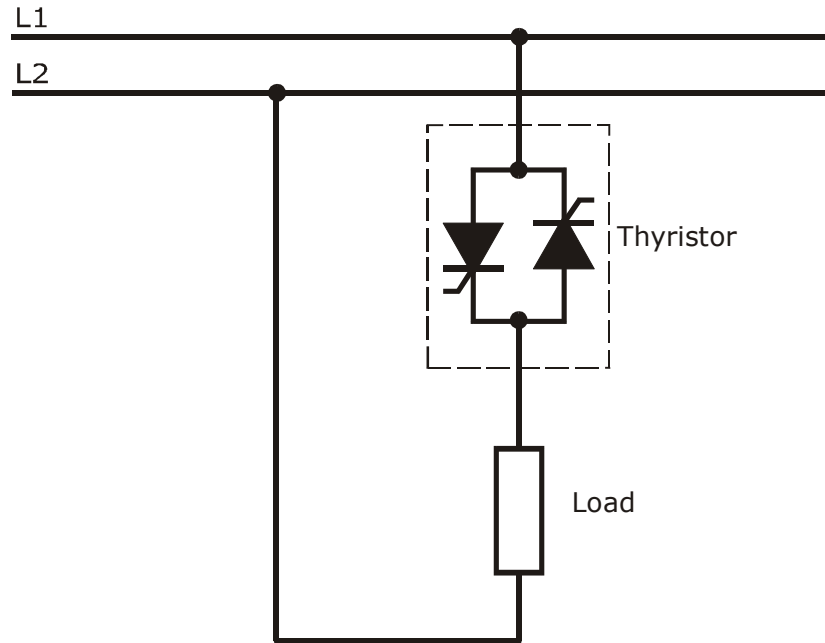

2.1 Advantages compared with analog thyristor unit

Communication RS485 is a standard feature of CD3200 this allows the use of many information like: current, power, load state and all the parameters for diagnostic and configuration. Ulterior advantages of the digital system vs the analogical is the flexibility and the possibility of implement special characteristics without change the hardware. Several strategies can be implemented and selected through the configuration parameters.

With CD-KP, you can have access to the configuration parameters without expose at the dangerous voltage inside the cabinet and without stop the plant.

CD THYRISTOR UNIT
INSIDE CABINET



CD-KP
ON FRONT DOOR



PC FOR CONFIGURATION



RS-485 MODBUS

RS-232

2.2 CD-KP

The CD-KP is designed to be connected with all CD Automation's Thyristor units via RS485 communication. On front unit is possible to read the principal operational parameters of the unit like: power, tension, current, reference, alarms, etc.

One of these variables can be selected and retransmitted via an isolated output (4÷20mA or 0÷10V) All the menus (except the operator menu) can be protected by password to avoid accidental change of configuration parameters by unauthorised personnel.

On front unit is also available a plug-in connector RS485 for connect a PC with the Thyristor units without open the cabinet and without stop the production process.

Technical Specification:

- Use in Local/Remote
- Set Point Ramp UP - Down
- Scroll selection of:
 - Set point
 - Power output
 - Current
 - Voltage
- Display indication for:
 - Heater Break alarm
 - SCR short circuit
- Password for configuration parameters
- Plug-in connector on front to use software configurator
- Retransmission (4-20mA or 0-10Vdc) of one of these parameters: Power PV, Current, Voltage.
- Dimension 48x96x92mm (LxAxP)
- Comply with EMC, CE marked



2.3 CD-EASY

CD-EASY is a Memory of support used for maintenance people that is not confident in personal computer.

With the CD-EASY is possible memorize the configuration of one Thyristor Unit and paste it into another in few seconds.

CD-EASY could be loaded with the personal configuration of the unit and stored together with the system drawings in a convenient place, enabling unit reconfiguration within seconds if require.

CD THYRISTOR UNIT 1

CD THYRISTOR UNIT 2



2.4 Software Configurator

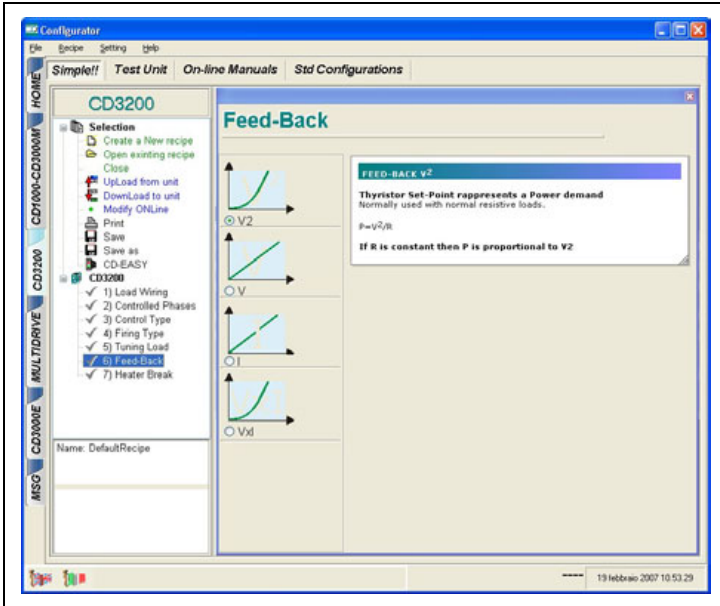

The software configuration is free and is possible download it from our site: www.cdautomation.com

If the Order Code is in line with requirement, then CD3200 has been already configured in Factory and it's ready to use. You need the software only to modify the ordered configuration. Anyway we suggest to check the unit on the machine with the "Test unit" section.

For install the software, launch the program and follow the instructions on the screen.



To connect the unit at the PC, it's necessary use the programming cable connected between the PG connector (see par. 11.6) and the serial port RS232 of the PC.

The programming cable is not included.



With the CD-RS serial converter is possible configure the Thyristor unit also through the RS485 (see par. 11.7). For this solution, the programming cable is not necessary.

Run the software configurator and set the serial port of the PC with con baudrate =9600 and the address of Thyristor unit (default=1).

3 Quick Start



Caution: this procedure must be performed only by qualified persons.

If the Order Code of the Thyristor unit is in line with what you really need, then CD3200 has been already configured in Factory and you just need to do the following steps:

1. Verify the CD3200 Sizing. Making sure that:
 - The load current is equal or less than the MAX current of CD3200.
 - The load voltage is equal or less than the MAX voltage of CD3200.
 (see par. 4)
2. Verify the Order Code
(see par. 5.2)
3. Verify the Installation
(see par. 6)
4. Verify the Diagram of control connection:
 - All auxiliary connections must be done in line with wirings on this manual.
 - Verify that there isn't a short circuit on the load.
 - Verify that the Reset Contact on terminal 7 and 8 are closed.
 - With External Enable option give Enable to the unit.
 (see par. 7.5)
5. Supply the Electronic boards
(see Order Code)
6. Supply the Fan at 230VAC $\pm 15\%$ 50/60Hz (110VAC $\pm 15\%$ 50/60Hz Optional)
(see par. 8.2)
7. Supply the Power unit
(see par. 7.3)
8. Make the Calibration procedure
(see par. 9.3)

The CD3200 Thyristor unit is ready to start.

4 CD3200 Sizing

4.1.1 Wiring with resistive load

$$I = \frac{P}{V}$$

V = Nominal voltage phase to phase

I = Nominal current to the load

P = Nominal power to the load

4.1.2 Wiring with inductive load

$$I = \frac{P}{V \cos \phi}$$

V = Nominal voltage phase to phase

I = Nominal current to the load

P = Nominal power to the load

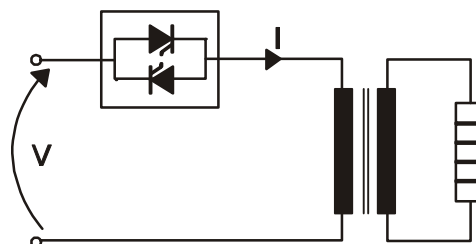
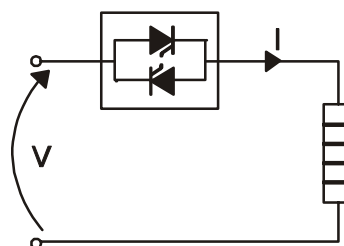

5 Identification and Order Code

5.1 Identification of the unit



Caution: Before to install, make sure that the Thyristor unit have not damages. If the product has a fault, please contact the dealer from which you purchased the product.

The identification's label give all the information regarding the factory settings of the Thyristor unit, this label is on the unit, like represented in figure.

Verify that the product is the same thing as ordered (see par. 5.2).



5.2 Order Code

Model	1	2	3	4	5	6	7	8	9
CD3200									

1	Max Current of CD3200								
	125A		200A		400A		600A		
	150A		300A		500A		700A		
The Max Current must be equal or more than Load Current									

2	Load Current								
Specify this value to configure the unit in CD Automation									

3	Load Voltage								
Specify this value to configure the unit in CD Automation									

4	Max Voltage of CD3200								
	480V								
	600V								
The Max Voltage must be equal or more than Load Voltage									

5	Auxiliary Voltage (Voltage supply for the Electronic boards)								
	90:130	From 90 to 130Vac; 10VA							
	170:265	From 170 to 265Vac; 10VA							
	230:345	From 230 to 345Vac; 10VA							
	300:530	From 300 to 530Vac; 10VA							
	510:690	From 510 to 690Vac; 10VA							

6	Input								
	0÷10V	0÷10Vdc							
	4÷20mA	4÷20mA							
	POT	Potentiometer 10KΩ							

7	Firing Type								
	S+PA	Soft Start + Phase Angle							
	PA	Phase Angle							

8	Feed Back								
	V	Voltage							
	I	Current							
	V2	Voltage square							
	VxI	Power (VxI)							

9	Option								
	NCL	No current limit							
	CLP	External current limit profiling (0÷10Vdc)							
	EN	Opto isolated external enable							
	FBS	Opto isolated Feed-back Selection							
	IF	Internal fuses (standard)							
	NF	No fuses							
	HB	Heater Break Alarm							
	CD-KP	External Keypad							
	110Fan	Fan voltage supply 110VAC ± 15% (std 230VAC ± 15%) 50/60Hz							
	UL	UL Certification							

6 Installation



Caution: Don't install near the hot elements or near the units that could give electromagnetic interferences.

The CD3200 Thyristor unit must be always mounted in vertical position to improve air cooling on heat-sink. Maintain the minimum distances in vertical and in horizontal as represented.

When more unit has mounted inside the cabinet maintain the air circulation like represented in figure. Sometimes is necessary installing a fan to have better air circulation.

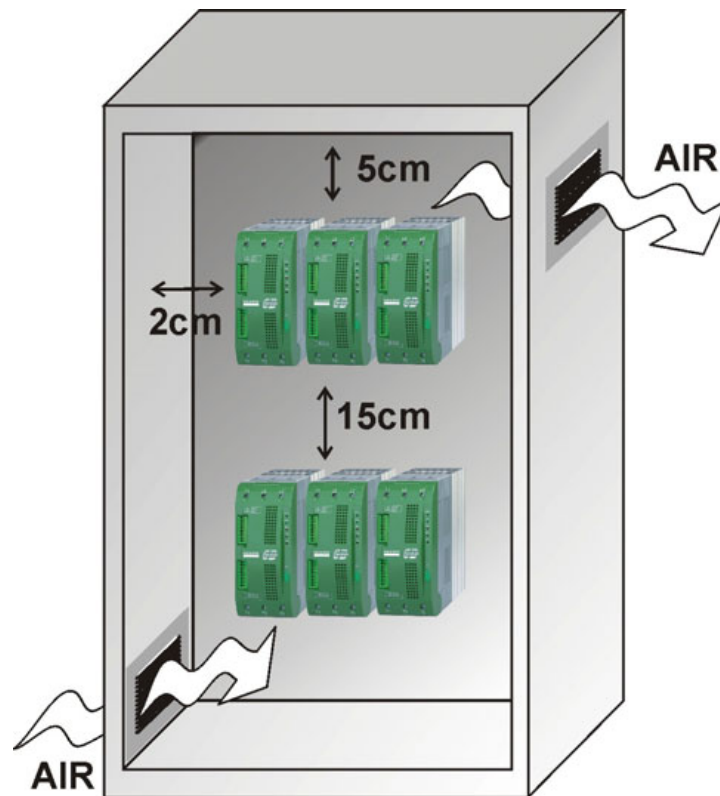

6.1 Environmental installation conditions

Ambient temperature	0-45°C at nominal current. Over 45°C use the derating curve (see par. 8.1)
Storage temperature	-25°C to 70°C
Installation place	Don't install at direct sun light, where there are conductive dust, corrosive gas, vibration or water and also in salty environmental.
Altitude	Up to 1000 meter over sea level. For higher altitude reduce the nominal current of 2% for each 100m over 1000m
Humidity	From 5 to 95% without condense and ice

6.2 Dimensions and Weight

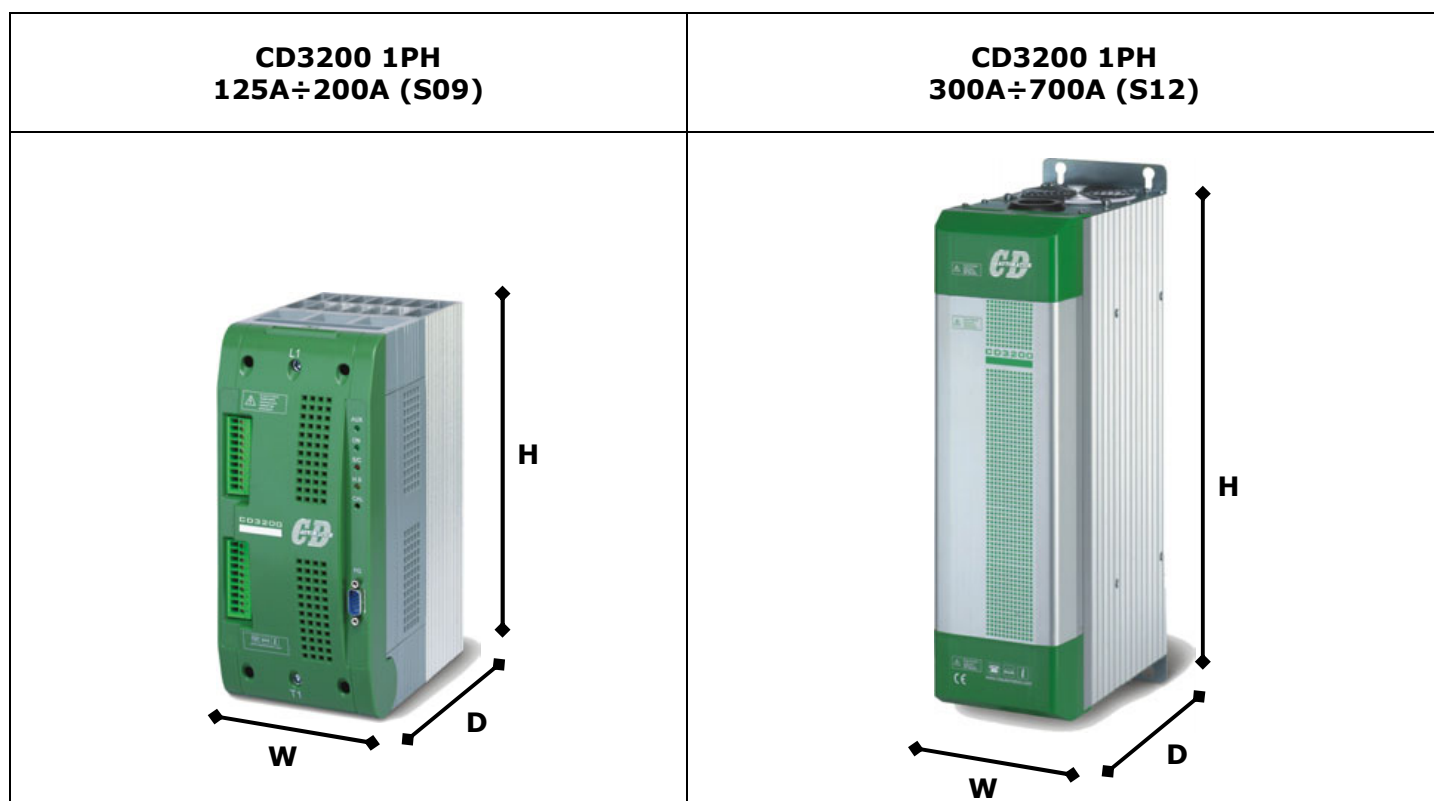

Size	W(mm)	H(mm)	D(mm)	Weight (kg)
125A (S09)	116	316	187	5
150A (S09)	116	316	187	5
200A (S09)	116	316	187	5
300A (S12)	137	520	270	15
400A (S12)	137	520	270	15
500A (S12)	137	520	270	15
600A (S12)	137	520	270	15
700A (S12)	137	520	270	15

6.3 Fixing holes

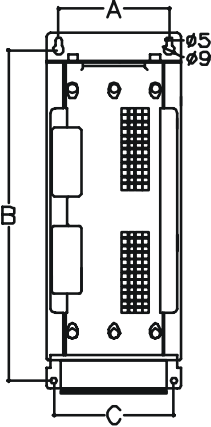
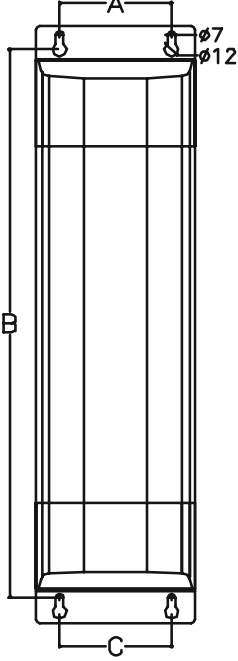
CD3200 1PH 125A÷200A (S09)	CD3200 1PH 300A÷700A (S12)
	

Size	A(mm)	B(mm)	C(mm)
125A (S09)	96	290	104
150A (S09)	96	290	104
200A (S09)	96	290	104
300A (S12)	97	490	97
400A (S12)	97	490	97
500A (S12)	97	490	97
600A (S12)	97	490	97
700A (S12)	97	490	97

7 Wiring instructions



Caution: this procedure must be performed only by qualified persons.

The Thyristor unit could be susceptible to interferences lost by near equipments or by the power supply, for this reason in accord to the fundamental practices rules is opportune take some precautions:

- The electronic circuit of the Thyristor unit must be supplied from a dedicated voltage and not with inductive or capacitive loads. We recommend the use of a screened transformer.
- The coil contactor, the relays and other inductive loads must be equipped with opportune RC filter.
- Use shielded bipolar cables for all the input and output signals.
- The signal cables must not be near and parallel to the power cables.
- Local regulations regarding electrical installation should be rigidly observed.

For safety connect the heat-sink to the earth with his terminal.

7.1 Removing the cover

Instructions for open the thyristor unit size S9



Instructions for open the thyristor unit size S12



7.2 Wiring details

Use copper cables and wires rated for use at 75°C only.

7.2.1 Power cable torque (suggested)

Current	Connector Type	Torque Lb-in (N-m)	Wire Range AWG / kcmil	Wire Terminal
125A, 150A, 200A,	Terminal Block M8	265 (30.0)	1 3/0	Copper wire Compact (Solid) Stranded
300A	Bus Bar with M8 screw	505 (57.0)	2x1/0 350	UL Listed (ZMVV) Copper Tube Crimp. Lug
400A	Bus Bar with M10 screw	505 (57.0)	2x3/0 600	UL Listed (ZMVV) Copper Tube Crimp. Lug
500A	Bus Bar with M10 screw	505 (57.0)		Bus bar 60x4mm
600A	Bus Bar with M10 screw	505 (57.0)		Bus bar 60x5mm
700A	Bus Bar with M10 screw	505 (57.0)		Bus bar 60x6mm

7.2.2 Power cable dimensions (suggested)

Current	Supply			Load		
	Cable		Screw M	Cable		Screw M
	mm ²	AWG		mm ²	AWG	
125A (S09)	50	1	M8	50	1	M8
150A (S09)	70	1/0	M8	70	1/0	M8
200A (S09)	95	3/0	M8	95	3/0	M8
300A (S12)	2 x 70	2 x 1/0	M8	2 x 70	2 x 1/0	M8
400A (S12)	2 x 95	2 x 3/0	M10	2 x 95	2 x 3/0	M10
500A (S12)	Bus Bar		60 x 4 mm	Bus Bar		60 x 4 mm
600A (S12)	Bus Bar		60 x 5 mm	Bus Bar		60 x 5 mm
700A (S12)	Bus Bar		60 x 6 mm	Bus Bar		60 x 6 mm

7.2.3 Cable dimensions (suggested) of Earth and of the Command Terminals

Current	Earth			Command Terminals		
	Cable		Screw M	Cable		
	mm ²	AWG		mm ²	AWG	
125A (S09)	16	6	M6	0,50	18	
150A (S09)	16	6	M6	0,50	18	
200A (S09)	25	4	M6	0,50	18	
300A (S12)	50	1	M8	0,50	18	
400A (S12)	50	1	M8	0,50	18	
500A (S12)	70	1/0	M8	0,50	18	
600A (S12)	70	1/0	M8	0,50	18	
700A (S12)	70	1/0	M8	0,50	18	

7.3 Power Terminals



Warning: Before connecting or disconnecting the unit check that power and control cables are isolated from voltage sources.

Terminal	Description
L1	Line Input Phase 1
T1	Load Output Phase 1

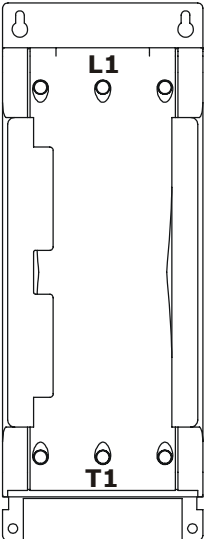
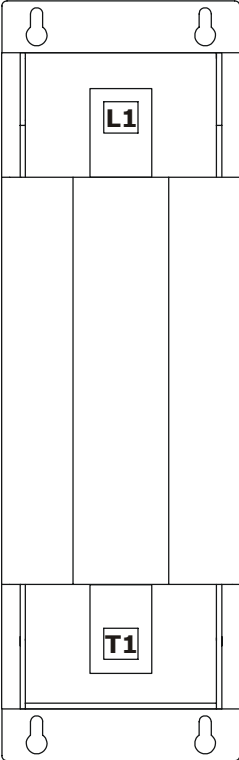
<p style="text-align: center;">CD3200 1PH 125A÷200A (S09)</p>	<p style="text-align: center;">CD3200 1PH 300A÷700A (S12)</p>
	

7.4 Command Terminals



Warning: Before connecting or disconnecting the unit check that power and control cables are isolated from voltage sources.

Terminal	Description
1	Voltage Supply for Electronic Boards (Auxiliary see par. 11.2)
2	Not Used
3	Voltage Supply for Electronic Boards (Auxiliary see par. 11.2)
4	Earth
5	Fan supply voltage (see par. 8.2)
6	Fan supply voltage (see par. 8.2)
7	RESET
8	RESET
9	(+)Input command signal 0÷10V,4÷20mA,POT
10	(-)Input command signal 0÷10V,4÷20mA,POT

Terminal	Description
11	0V GND
12	Output +8Vdc stabilized 1 mA MAX
13	(+)Output command for Slave unit
14	(-)Output command for Slave unit
15	(+)External Calibration 24 Vdc max
16	(-) External Calibration 24 Vdc max
17	External current limit profiling
18	HB relay contact NC (Max 500mA , 125Vac) Optional (see par. 11.5)
19	Common HB relay contact (Max 500mA , 125Vac) Optional
20	HB relay contact NO (Max 500mA , 125Vac) Optional (see par. 11.5)



7.5 Diagram of control connection



Caution: this procedure must be performed only by qualified persons.

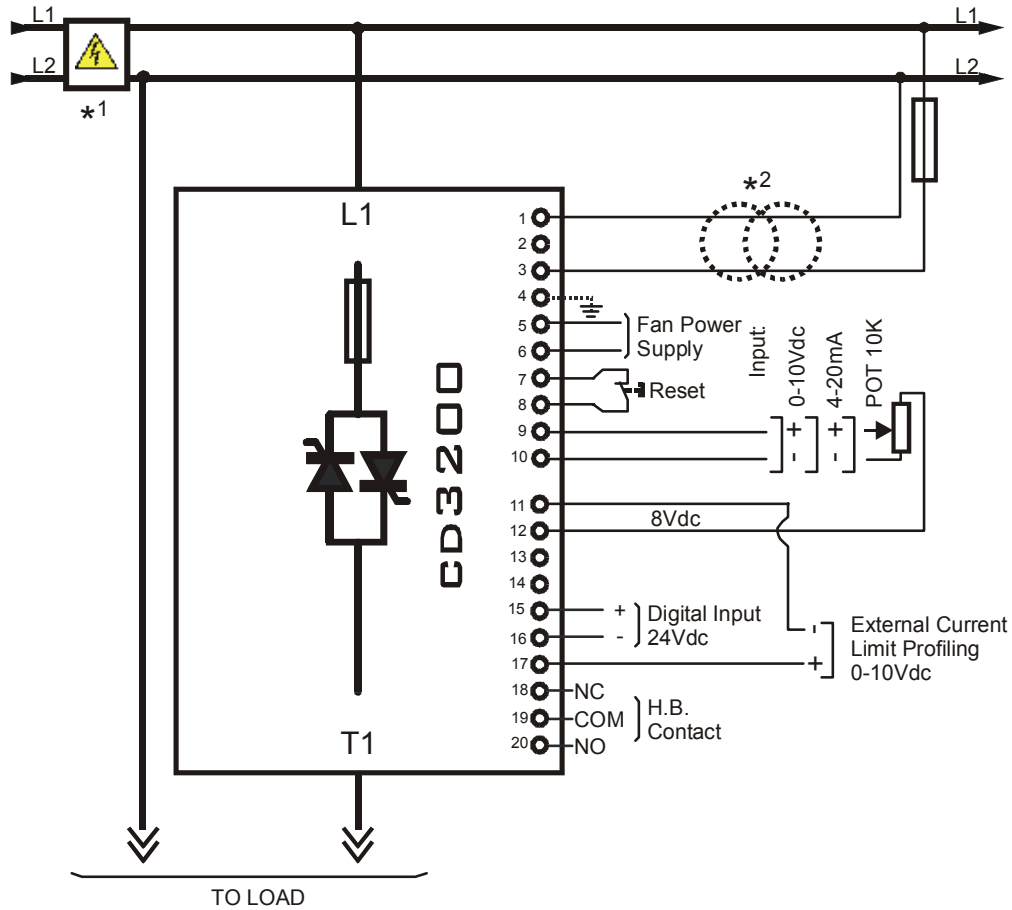

NOTE:

- *1 The user installation must be protecting by electromagnetic circuit breaker or by fuse isolator.
- *2 The auxiliary voltage supply of the CD3200 unit must be synchronized with load voltage power supply. If the Auxiliary Voltage (written on the identification label) is different from Supply Voltage (to the load), use an external transformer as designated.
- To work, the Reset Contact on terminal 7 and 8 must be closed.

Load Type

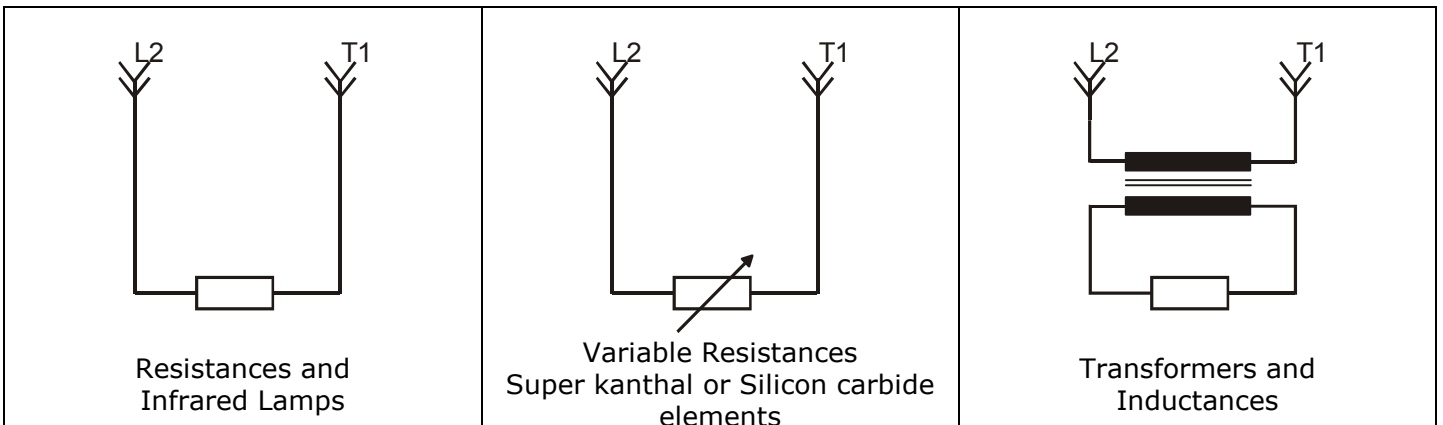

8 Power output features

Current (A)	Voltage range (V)	Repetitive peak reverse voltage		Latching current (mAeff)	Max peak one cycle (10msec.) (A)	Leakage current (mAeff)	I ² T value max tp=10msec	Frequency range (Hz)	Power loss I=Inom (W)	Isolation Voltage Vac
		(480V)	(600V)							
125A	24÷600	1200	1600	450	1540	15	11300	47÷70	146	2500
150A	24÷600	1200	1600	450	2000	15	19100	47÷70	162	2500
200A	24÷600	1200	1600	300	4800	15	108000	47÷70	204	2500
300A	24÷600	1200	1600	300	5250	15	128000	47÷70	320	2500
400A	24÷600	1200	1600	200	7800	15	300000	47÷70	397	2500
500A	24÷600	1200	1600	200	8000	15	306000	47÷70	530	2500
600A	24÷600	1200	1600	1000	17800	15	1027000	47÷70	589	2500
700A	24÷600	1200	1600	1000	17800	15	1027000	47÷70	712	2500

8.1 Derating curve

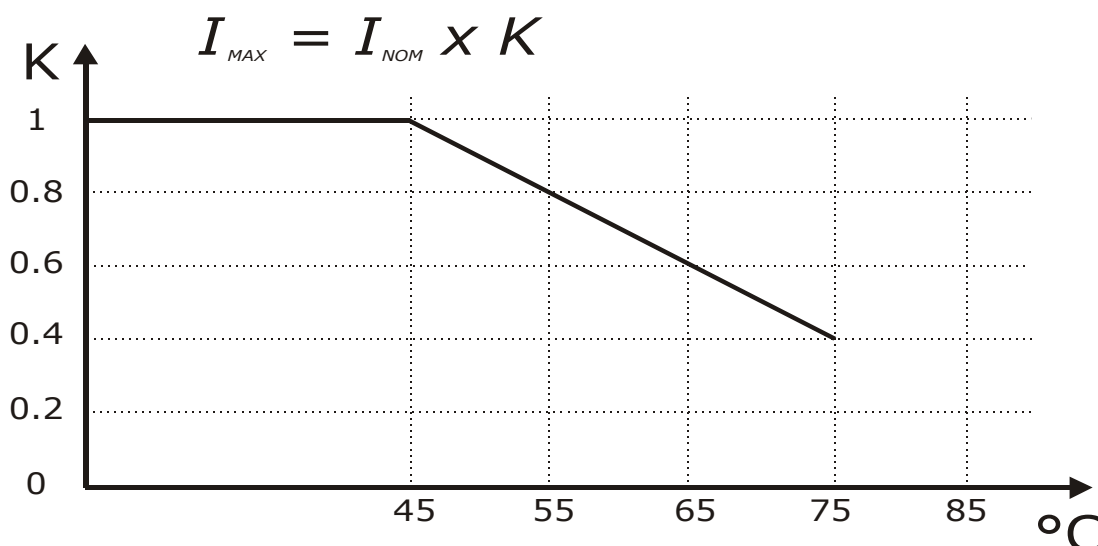

8.2 Cooling fans

The CD3200 thyristor unit is equipped with a cooling fans. The supply voltage is standard 230VAC ±15% 50/60Hz or optional 110VAC ±15% 50/60Hz.



The fan's power consumption is below listed:

Size	CE Number of fans	cUL us LISTED Number of fans
125A, 150A	One Fan - 16W	One Fan - 16W
200A, 300A, 400A, 500A, 600A	One Fan - 16W	Two Fans - 30W
700A	Two Fans - 30W	Two Fans - 30W

9 Led status and Alarms

9.1 LED Status Table

In front of the thyristor unit there are LED that indicates the state of the Electronic cards:

LED For All size	STATUS	DESCRIPTION
Aux	○	The power supply is not connected or fault on the electronic board
	●	The power supply is not connected and the Electronic board is OK
ON	○	OFF Condition (Load IS NOT Powered)
	●	ON Condition (Load IS Powered)
SC	○	SCR OK
	●	SCR short circuit
		No External Enable (see par. 11.4)
HB	○	Load OK
	●	Load Fault
	○	= OFF
	●	= ON
		= Flashing

9.2 Not Critical Alarm

The Not Critical Alarm, doesn't stop the thyristor unit.

When one of these Not Critical Alarm is active, the HB relay change status (see par. 11.5)

9.2.1 SCR Short Circuit (only with the HB option)

This alarm is active when the thyristor unit read the output current in absence of the input signal. This is possible if there are a short circuit on the thyristor or if there are a wrong wiring of the load.

When the problem is solved is necessary use the digital input: "Reset"
(Terminals 7-8)

9.2.2 Heater Break alarm HB (only with the HB option)

This alarm is active when the load current decrease under the threshold set on the parameter P124H (see par. 13).

The Heater Break alarm could be active also if there are a wrong wiring of the load.

When the problem is solved is necessary use the digital input: "Reset"

(Terminals 7-8).

H.B. circuit read load current via a current transformer internal to the unit.

Minimum current is 10% of the current transformer size's.

The current transformer size's depending to the thyristor unit size.



Caution: *In the first start, and each time that the load is replaced, it's necessary make the Calibration procedure.*

9.3 Calibration Procedure

The Calibration procedure is an automatic procedure that save in memory the value of load current.

To make the Calibration procedure follow these steps:

- Turned completely in counter-clockwise sense the trimmer R13 (see par 10.3)
- Give the power supply
- Press the "CAL" button on front unit of the S09 size unit or on the CD3x00 board for S12 size unit, or use the configurable digital input (see par. 11.4).
- All LEDS are on, this means that calibration procedure is active.
- Turn the trimmer R13 in clockwise sense and set the wished current limit.
- After a minute the values of voltage and current are stored in memory.
- the CD3200 comes back to the initial situation.

The Calibration procedure is done.

10 Firing type

Choose an correct firing type allows to optimize the thyristor unit for the installed load.

The firing type has already configured in line with customer requirements that are defined in the Order Code. The Order Code is written on the identification label.

However, if you wish to change the firing type you can use the software configurator or the parameter on serial link (see par. 13).



Caution: *this procedure must be performed only by qualified persons.*

10.1 Phase Angle (PA)

The Phase Angle firing allow the control of the power on the load, for this firing the thyristor can be in conduction only for a part of the voltage cycle.

This part of the voltage cycle is adjustable in function of the input signal from 0 at 100%.

The PA firing is normally used for control the inductive loads, and is also possible control a primary of transformer coupled with the cold resistances like: Superkanthal, Molybdenum, Platinum, Tungsten or Quartz Lamp. The only disadvantage with phase angle is the possible generation of interferences that however can be reduced with opportune filters.

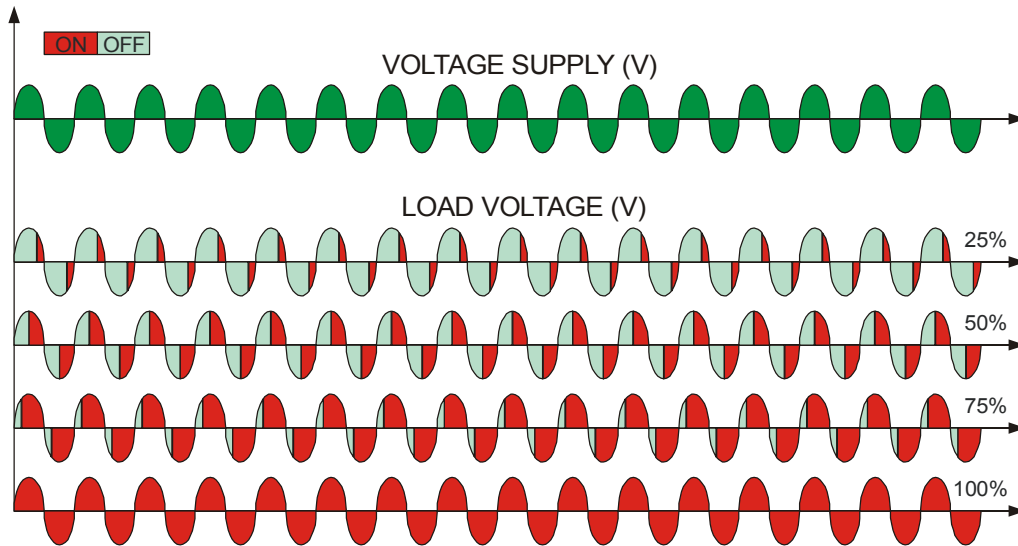

10.2 Soft Start with Phase Angle (S+PA)

This is an additional function to the Phase Angle. The firing angle of the thyristor increase or decrease up to the final setpoint value.

The Soft start ramp is an important feature to reduce the inrush current with transformers during the during the cycle of magnetization or with cold resistance that are near to the short circuit when they are supplied.

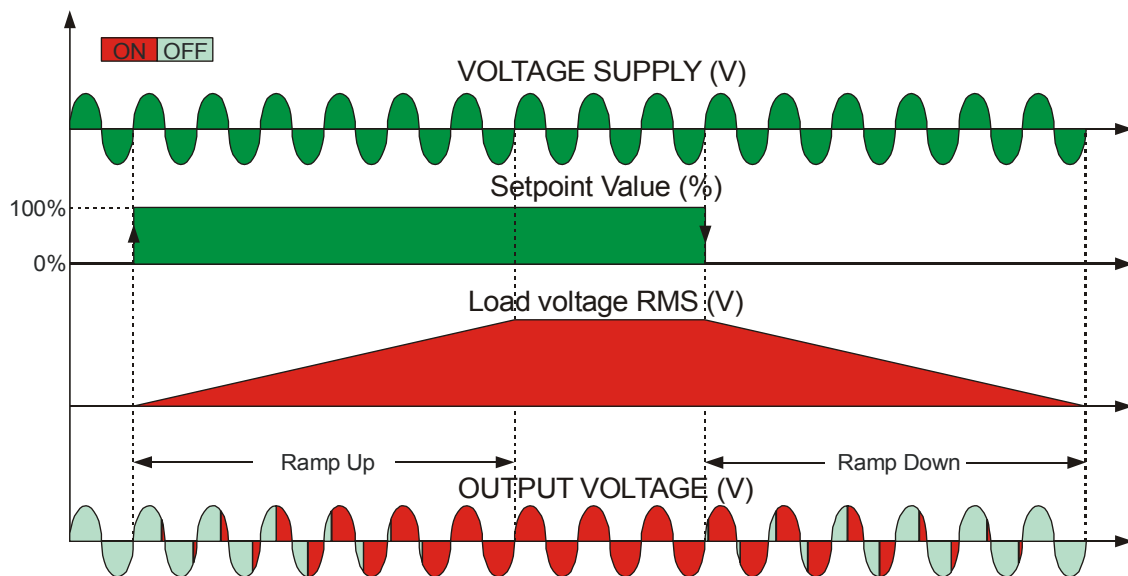

10.3 Action of the Limit Current

The Current Limit control the firing angle of the thyristor to maintain the RMS current under the set value.

When the current exceeds this value, the voltage is decreased up to reach the current limit set

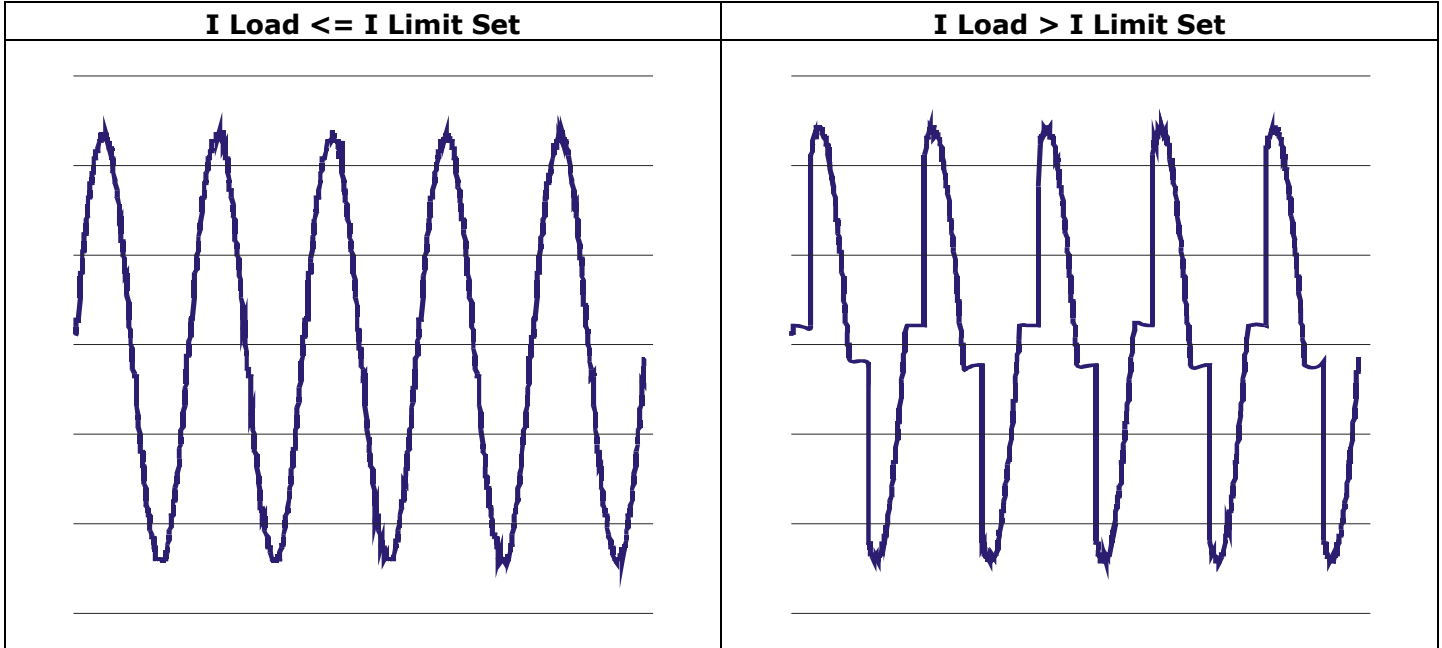

10.3.1 Current Limit Set

The Current limit is set up through the R13 trimmer on the CD3x00 board (see par. 11.1)

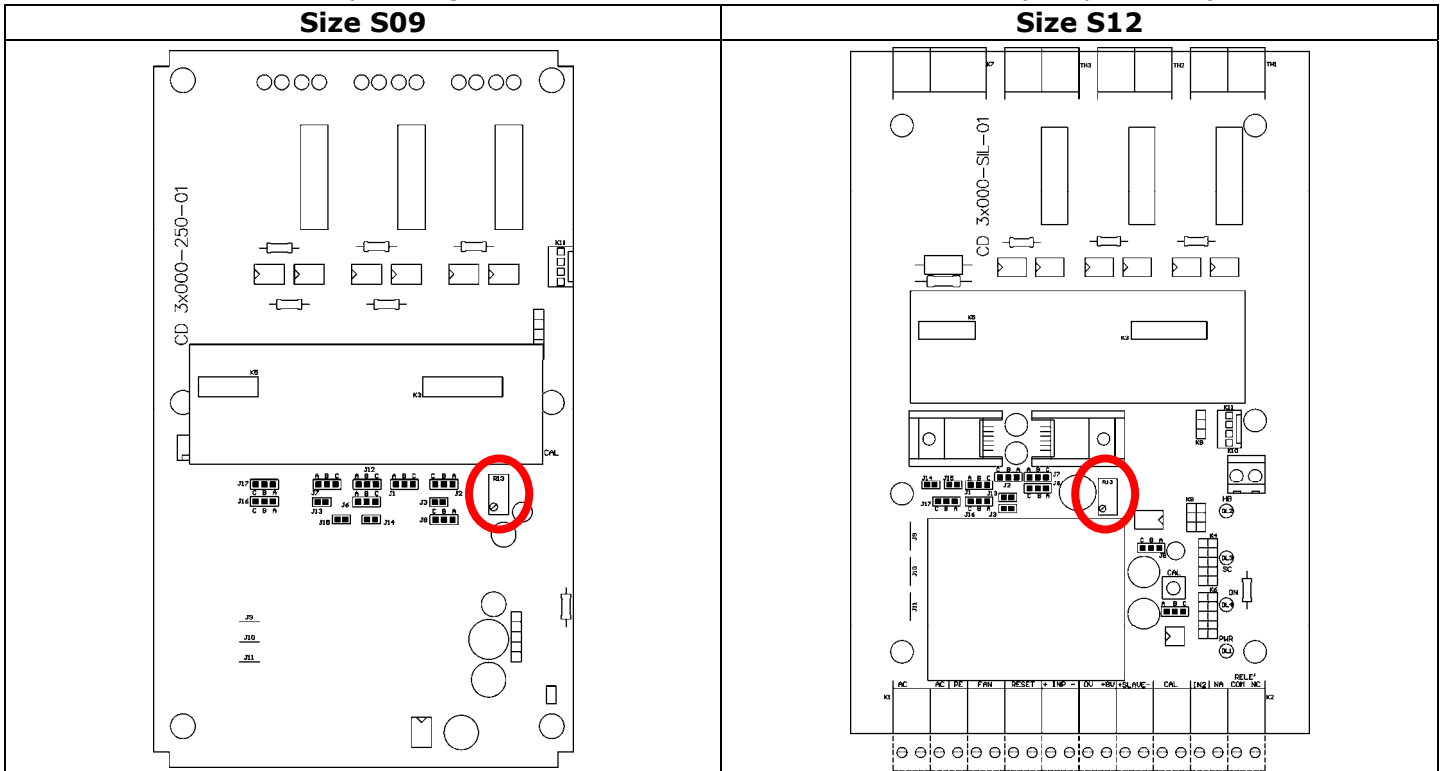

Turned completely in counter-clockwise sense, will be Current limit = 0%.

Turned completely in clockwise sense, will be Current limit = 100% of the Max value of current transformer (depending on thyristor size).

Minimum current is 10% of the current transformer size's. If load current is below this value H.B. circuit diagnoses fuse failure.

If the External current limit profiling is used, before turning the R13 trimmer, supplying with 10Vdc the secondary analogic input (see par. 11.3.3)..

10.4 Feed-back type

The Feed-back type has already configured in line with customer requirements that are defined in the Order Code. The Order Code is written on the identification label.

However, if you wish to change the Feed-back type you can use the software configurator or the parameter on serial link (see par. 13).



Caution: *this procedure must be performed only by qualified persons..*

If the configurable digital input has set like Feed-Back Selection (see par. 11.4), it's possible to change the select Feed-Back with the Voltage Feed-Back (V) simply activating the input.

The feed-back defines the Control Mode. It's possible to have:

- V=Voltage feed-back.
The input signal is proportional to the output voltage. This means that input signal becomes a voltage demand. This control mode compensates the voltage fluctuation of the incoming line supply.
- I=Current feed-back.
The input signal is proportional to the current output. This means that input signal becomes a current demand. This control mode maintain the current also if the load impedance changes.
- V²=Square Voltage feed-back.
The input signal is proportional to the output square voltage. This means that input signal becomes a power demand. The power remains constant if the load impedance doesn't change.
- VxI= Power feed-back.
The input signal is proportional to the power output. This means that input signal becomes a power demand. The power remains constant also if voltage and load impedance change. This feed-back is used with silicon carbide elements that change its resistive value with temperature and with age. In addition it compensate the voltage fluctuation of the incoming line supply.

If the user change the type of feed-back, it's necessary repeat the calibration procedure (see par. 9.3)

11 Connection description

11.1 Access to the Electronic boards

To have access to the electronic boards the user must removing the unit's cover (see par.7.1)



Warning: Before operate, be sure that power and control cables are isolated from voltage sources

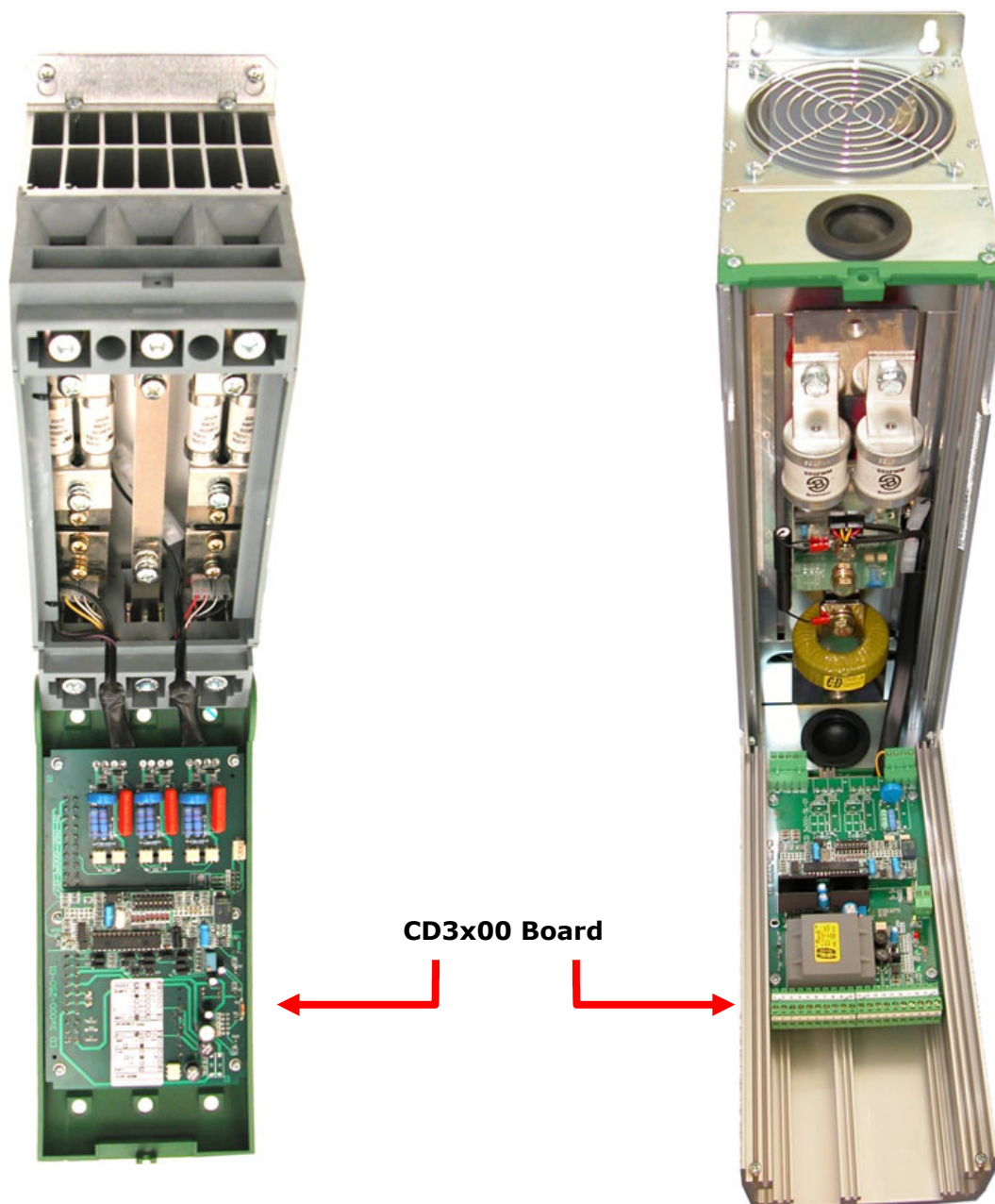

11.2 Supply the Electronic Board

The CD3200 thyristor unit, to work, requires a voltage supply for the electronic boards. The Max consumption is 10VA.

The voltage supply for the electronic boards is configured in line with customer requirements that are defined in the Order Code. The Order Code is written on the identification label.



Warning: Before connecting or disconnecting the unit check that power and control cables are isolated from voltage sources.

Terminal	Description
1	Voltage Supply for Electronic Boards (Auxiliary Voltage)
2	Not Used
3	Voltage Supply for Electronic Boards (Auxiliary Voltage)
4	Earth

To change auxiliary supply voltage sold the correct link-jumper on CD3x00 board
 The type of mounted transformer depends of the chosen Voltage in the order code.
 (See par. 5.2)

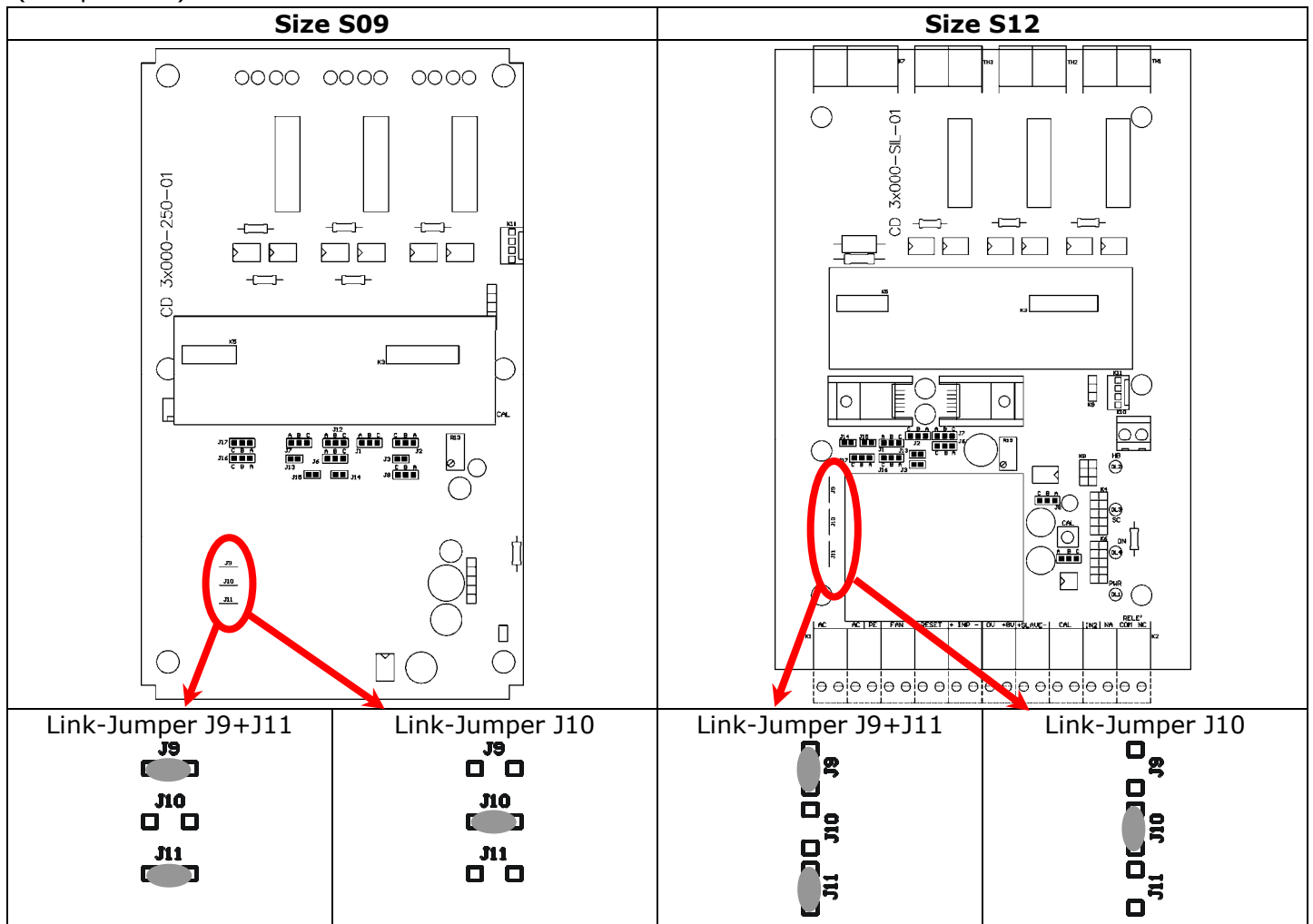

Transformer Type	Link-Jumper J9+J11	Link-Jumper J10
TR-605 120V	90:130V	-
TR-605 230V	170:265V	300:530V
TR-605 300V	230:345V	510:690V

If the Auxiliary Voltage (written on the identification label) is different from Supply Voltage (to the load), use an external transformer with primary equal to load voltage and secondary equal to the Auxiliary Voltage

11.3 Analog Inputs

CD3200 thyristor unit have an analogue input to drive the output power.

11.3.1 Input command signal configuration (Terminals 9 and 10 see par. 7.4)

The Input command signal is already configured in line with customer requirements that are defined in the complete product code. The product code is written on the identification label. However, if you wish to change the input type (i.e. from 0÷10V to 4÷20mA) proceed as follows:



Warning: this procedure can be done just by specialized personnel

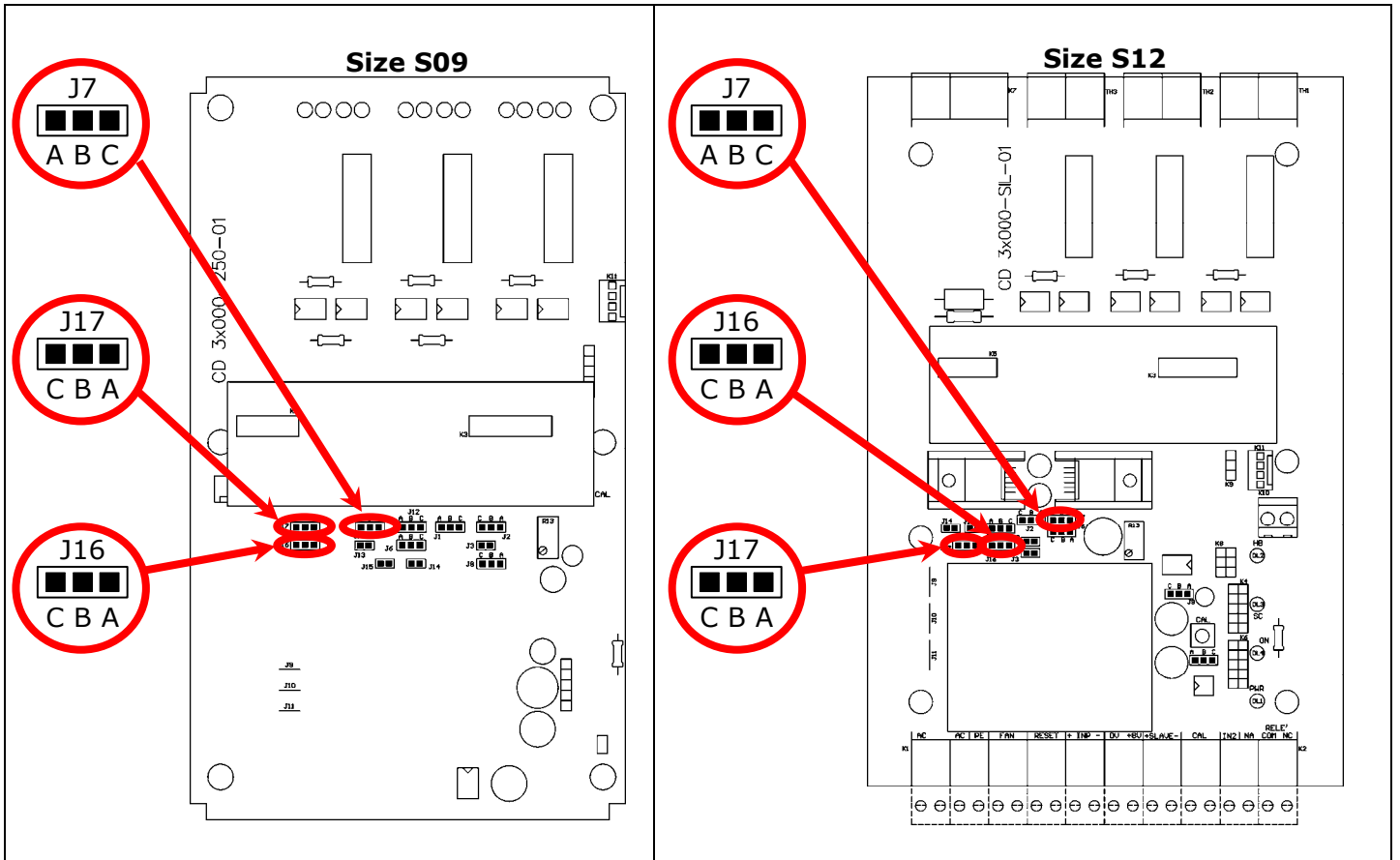

To configure the input type, set the jumper as below represented:

Type	Input features		J7	J16	J17
0÷10V	Impedance	10KΩ	C-B	B-A	B-A
POT	Impedance	10KΩ min	C-B	B-A	B-A
4÷20mA	Impedance	100Ω	B-A	B-A	B-A

When operator finishes to configure the hardware setting he must do the input calibration procedure

11.3.2 Input calibration procedure



Warning: this procedure can be done just by specialized personnel

This procedure is needed only if you change the input type

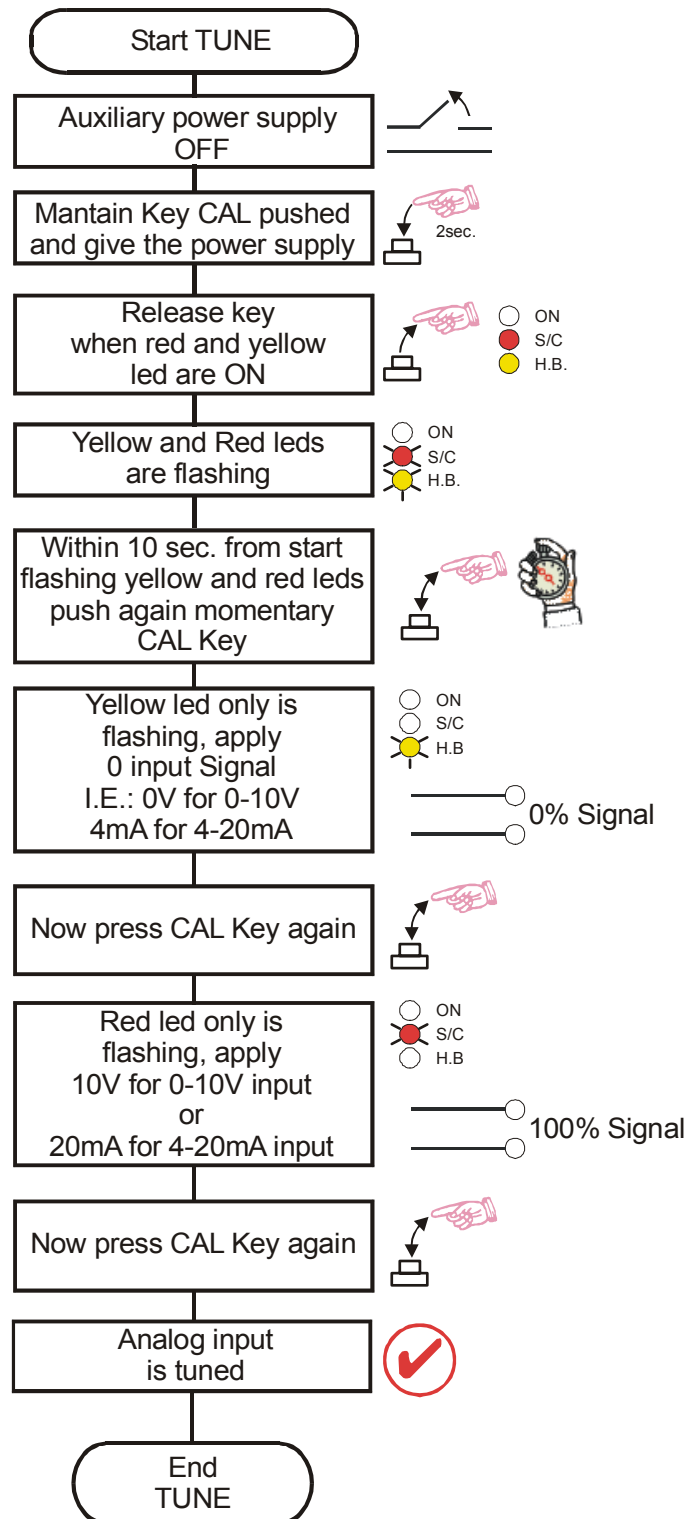

11.3.3 Secondary input (Terminals 11 & 17 see par. 7.4)

This analogue input 0-10V may be configured for External current limit profiling. The Secondary input is already configured in line with customer requirements that are defined in the complete product code. The product code is written on the identification label. However, if you wish to change the input type proceed as follows:



Warning: this procedure can be done just by specialized personnel

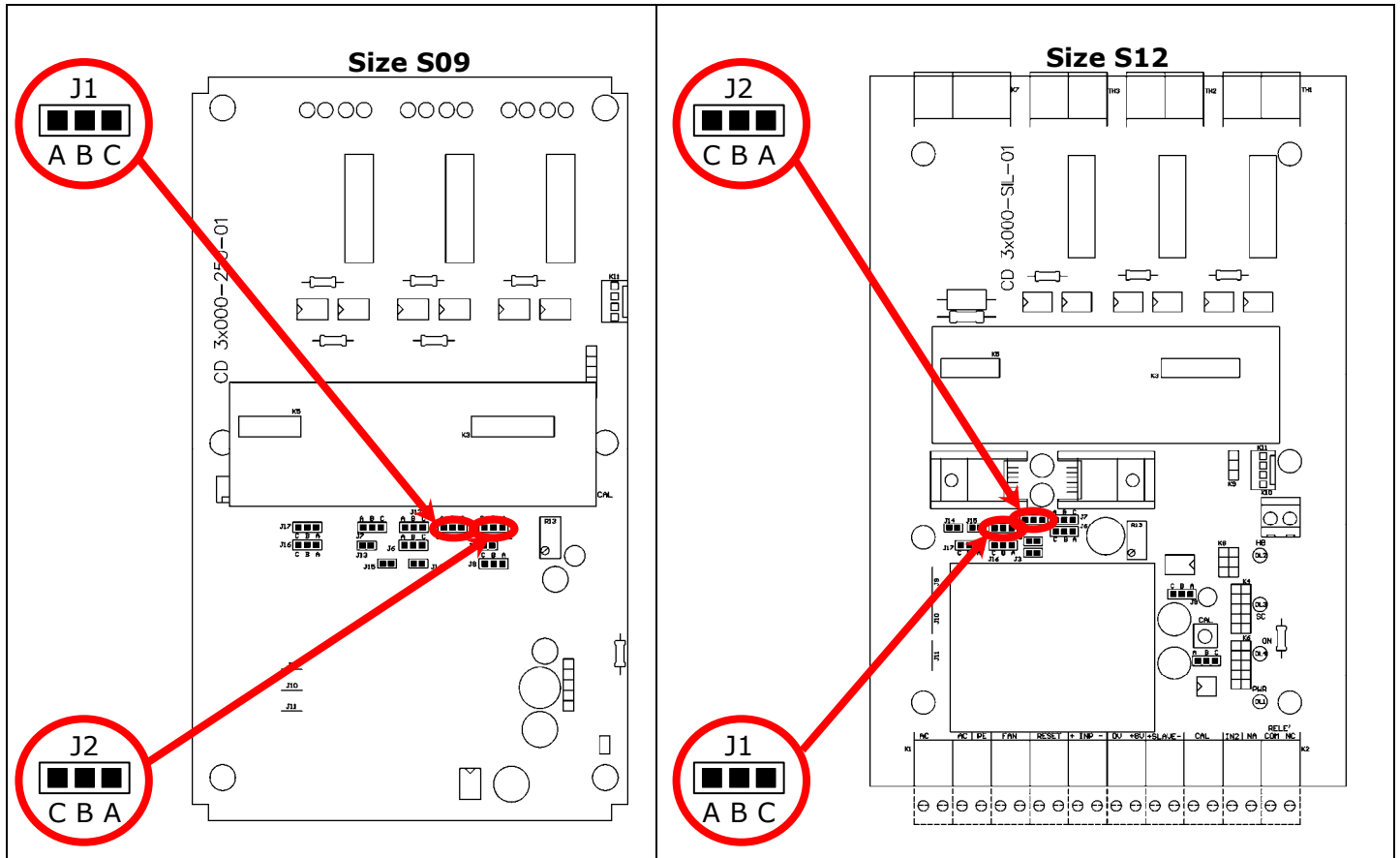

To configure the input type, set the jumper as below represented:

Current Limit	J2	J1
Regulation through the R13 trimmer, mounted on the the CD3x00 board. (secondary input not used)	C-B	C-B
Regulation through the secondary input (External current limit profiling)	B-A	C-B

If the user change the type of Secondary input, it's necessary repeat the calibration procedure (see par. 9.3)

11.4 Digital Input

CD3200 thyristor unit has two digital inputs.

11.4.1 Configurable Input (Terminals 15 and 16 see par. 7.4)

This digital input is configurable and can be:

- External Calibration (Standard):
The Calibration input activates the Calibration procedure that is necessary if you use the Heater break alarm (see par. 9.3). Supply with 24Vdc terminals 15-16 to start the Heater Break procedure.
- External Enable:
Without Enable the out is always to zero and red led (SC) flashing, otherwise the out will follow the input signal.
- Feed-back Selection:
to switch the set Feed-back with the voltage Feed-back (V)
Without Digital Input the Unit use the voltage Feed-back, otherwise use the set Feed-back.

To configure the input type, set the jumper as below represented:



Warning: this procedure can be done just by specialized personnel

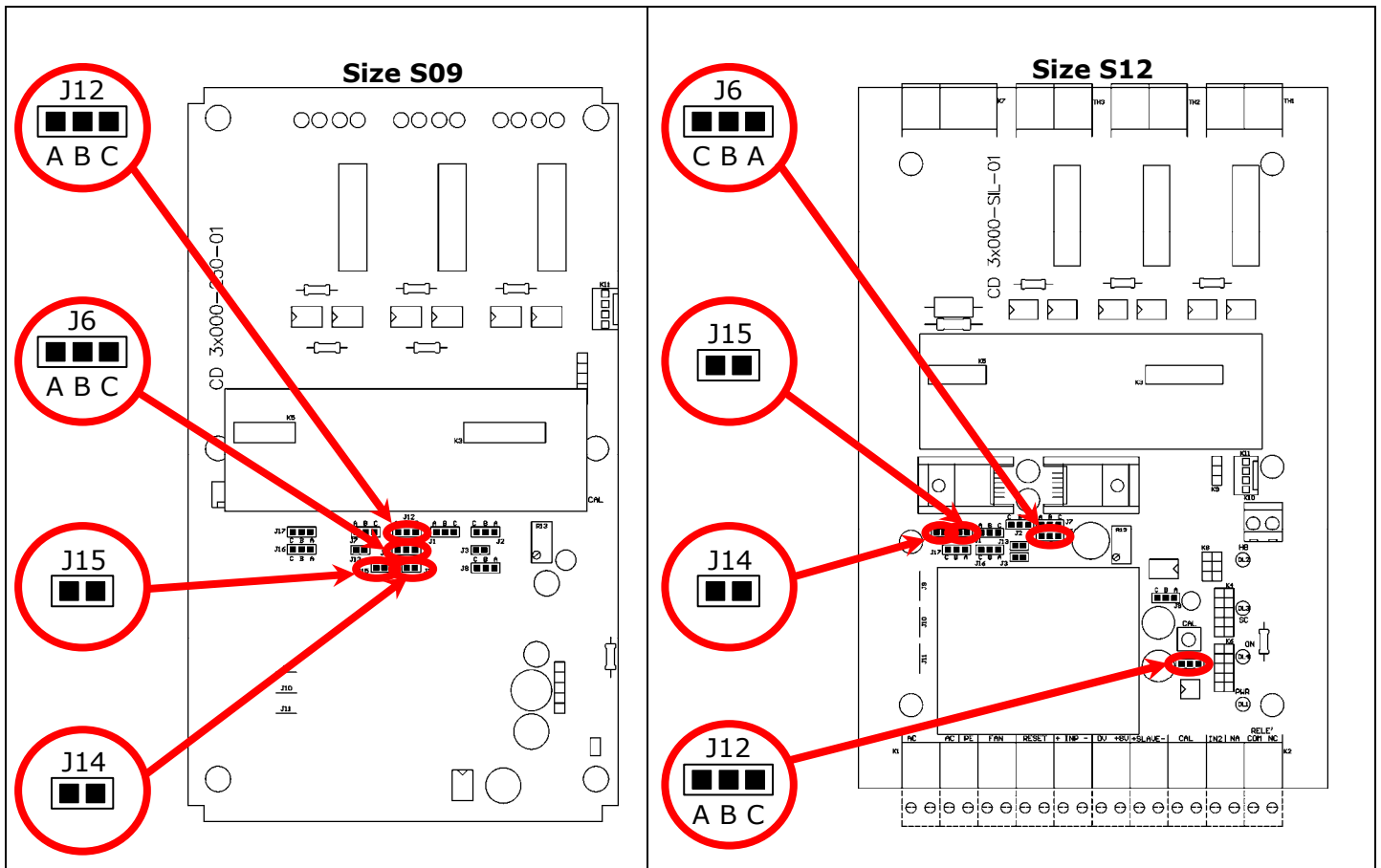

Type	J12	J6	J14	J15
External Calibration	C-B	C-B	Open	Close
External Enable	B-A	Open	Open	Close
Feed-back Selection	C-B	Open	Close	Open

If you use the input like External Enable, is not possible use the input for the "Heater Break procedure".

11.4.2 Reset (Terminals 7 and 8 see par. 7.4)

The Reset Alarm is used for restore the unit after an alarm occurs (see par. 9.2). Open link to terminals 7-8 to stop the CD3200 thyristor unit and reset the alarm.

11.5 Digital Output

CD3200 thyristor unit with HB option has 1 digital output with relay contact (Max 500mA, 125Vac) that gives indications of the alarms state, the contacts can be (NO and NC).

11.5.1 HB alarm contact (Only with HB Option - see par. 9.2)

The contact at terminals 19-20 is normally open (NO):

- In normal conditions (without alarm) and with auxiliary power supply, the contact to the terminals has opened (relay coil energized).
- In alarm condition or without auxiliary power supply the contact to the terminals is closed (relay coil not energized).

Also you can use the NC (closed without alarm) contact at terminals 18-19.

11.6 PG Connector

The PG Connector is used to configure the thyristor unit with the configuration software and with the programming cable. The programming cable is not included.

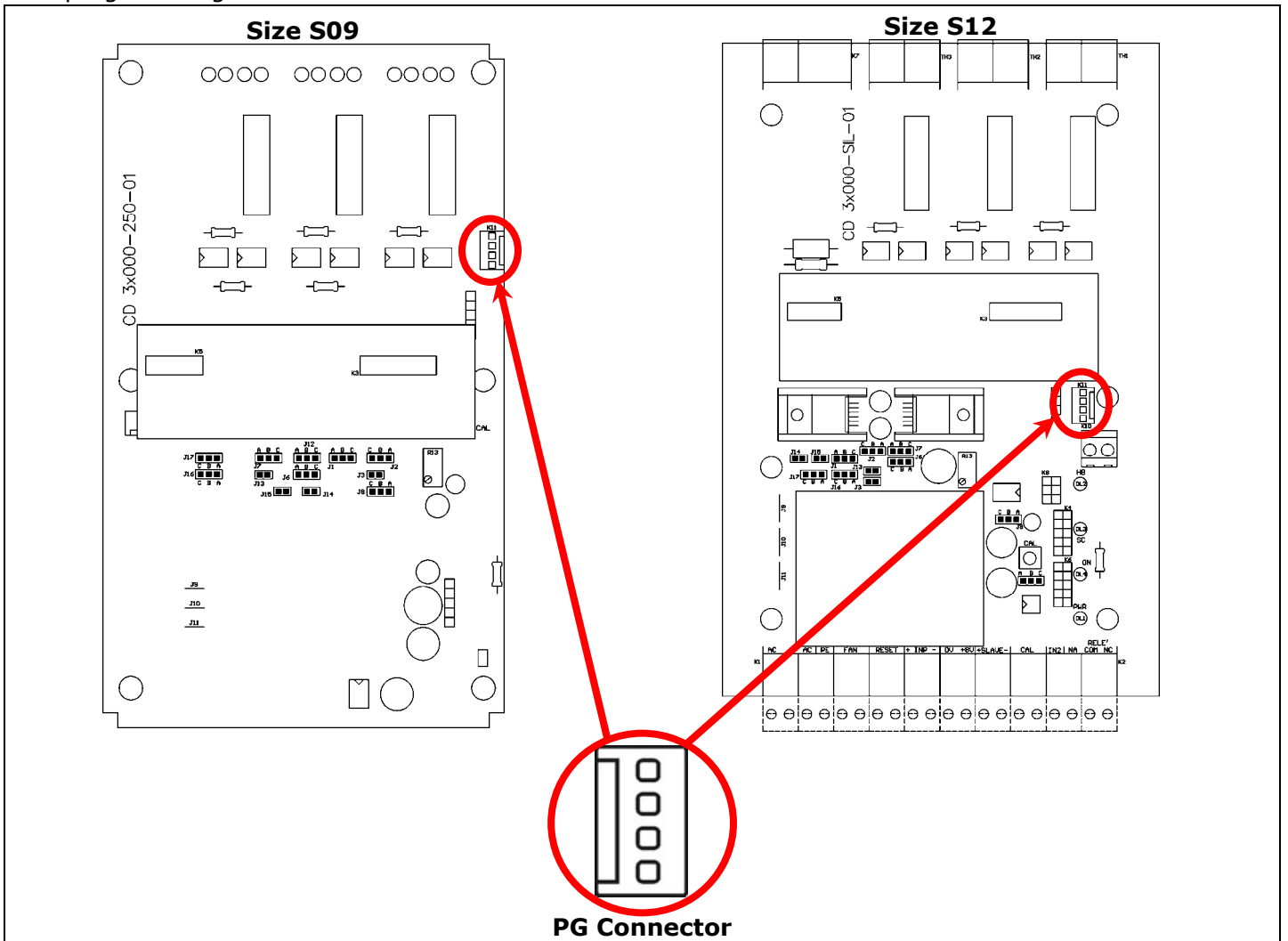

11.7 RS485 Serial Port

CD3200 have a serial communication port RS485.
 On this port may be done a network up to 255 unit.

Size S09

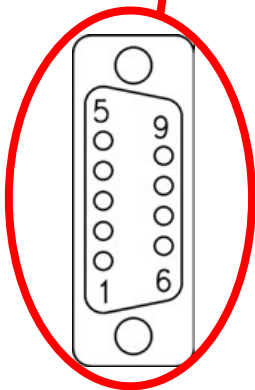

Pin	Description
1	PMS5 (+5V)
2	GND 0V
3	GND 0V
4	Riserved (Rxd0)
5	GND 0V
6	RS485 A
7	RS485 B
8	nc
9	Riserved (Txd0)

Size S12

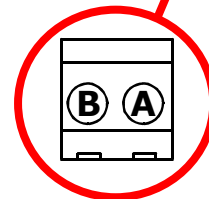
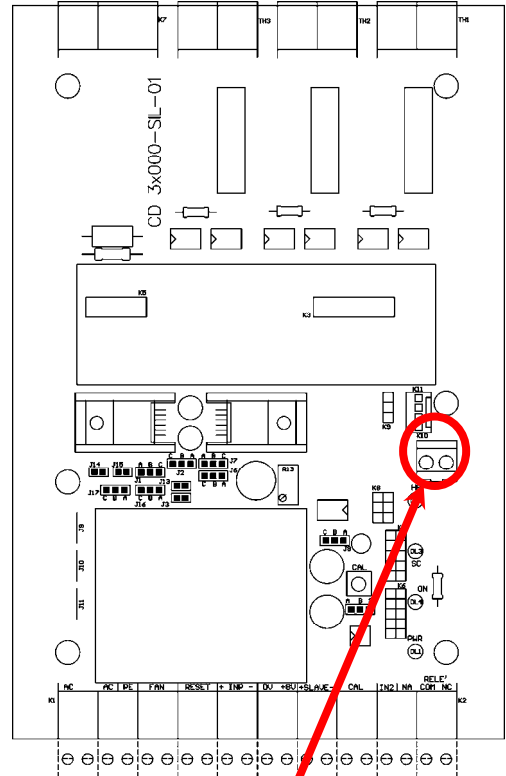

Terminal	Description
B	RS485 B
A	RS485 A

11.8 Address configuration

The thyristor unit is assigned a unique device address by the user in the range 1 (default) to 255. This address is used to recognise the messages queries to her assigned. The thyristor unit does not respond at the messages queries that don't have the same assigned address. The thyristor unit will also accept global messages (Broadcast) sends at the address 0. No responses are returned for globally addressed queries. To configure communication address remove cover and set the dip-switch as below specified:

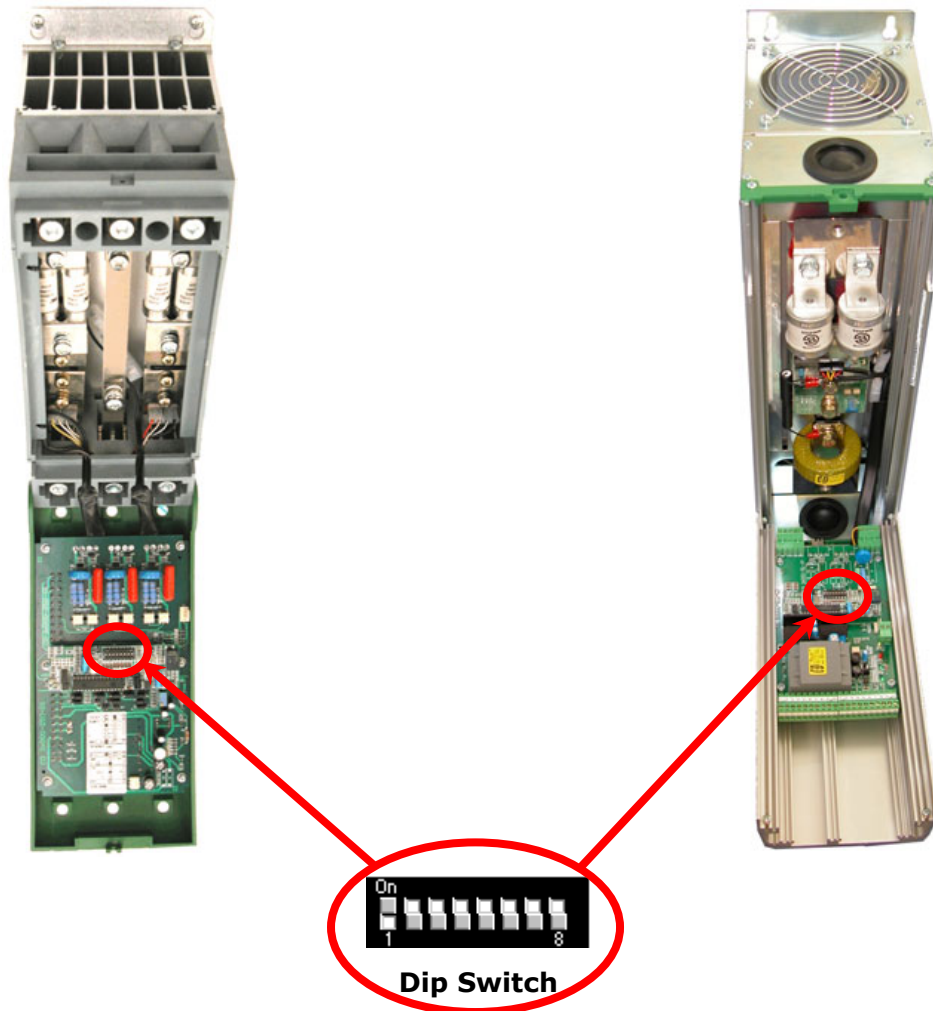

Convert the Address Number in Binary for Example: 150 Dec = 10010110 Bin
 The dip switch number corresponds to the bit number:

Address Number	Dip Switch Number							
	8	7	6	5	4	3	2	1
150 Dec -> 10010110 Bin	1 (On)	0 (Off)	0 (Off)	1 (On)	0 (Off)	1 (On)	1 (On)	0 (Off)

For convert the Number in Binary you can use this method:

Dip Switch Number have this value:

Value	Dip Switch Number							
	8	7	6	5	4	3	2	1
	128	64	32	16	8	4	2	1

The Address Number Ex. 150 = 128(Dip 8) + 16(Dip 5) + 4(Dip 3) + 2(Dip2)

12 MODBUS communication

The serial communication port of the thyristor unit is two-wire RS485 type.

This port use an half-duplex system.

When a Unit must transmit active the transmission line, and when there are not units in transmission the outputs are fixed to high impedance.

The serial communication port allows to communicate between the thyristor units and a MASTER device (ex. an computer or a terminal). The cable must be rated for use to data transfer.

12.1 MODBUS RTU Protocol

The communication is based on the standard industrial MODBUS RTU with the following restrictions:



- The Baud rate is 9600 Baud.
- The Preset Multiple Registers (Funct. 16) is limited to the writing of a single parameter for message.

The following MODBUS functions are supported:

Function	Description
03	Read Holding Registers
16	Preset Multiple Registers



The unit support the Broadcast messages:

It' possible send a Broadcast messages using the address 0, all the units respond at the message without sending back any reply.

12.2 Message Format

The transmission format is a 1 bit start, 8 date bit, and 1 bit stop with no parity verification.

Each message terminate after a said time of "time out", equal at 3.5 time of a character transmission, where there are not transitions on the transmission line.

The first Byte of each message is always the address of the unit that is a value from 1 to 255 or 0 for the broadcast messages, the second is always the function number, and the rest of the message depends of the function demand.



When a Slave receive an message, the unit send an answer with the same structure but with the information demanded.

Each message is followed by CRC (Cyclic Redundancy Check) with two byte. The CRC identify the incongruity situations of the message, in this case the receiver ignore the message.

The CRC is calculated in accordance with a formula that imply a recursive division of the data by a polynomial.

The polynomial divisor is:

$$2^{16} + 2^{15} + 2^2 + 1(\text{Hex } 18005)$$

but is modified in two ways:

- Since the bits order are reversed, then the binary pattern is also reversed, and the most significant bit (MSB) is the right-most bit.
- Since interest only the remainder, the right-most bit could be discarded.

Therefore, the polynomial divisor has value: Hex A001

Normal bit order:

Most significant bit																		Least significant bit
	Most significant Byte								Least significant Byte									

Reversed bit order:

Least significant bit																		Most significant bit
	Least significant Byte								Most significant Byte									

N.B.: With the reversed bit order, also the CRC16 returns the with the reversed bit order



The following flow-diagram show how to organize the CRC 16 bit.

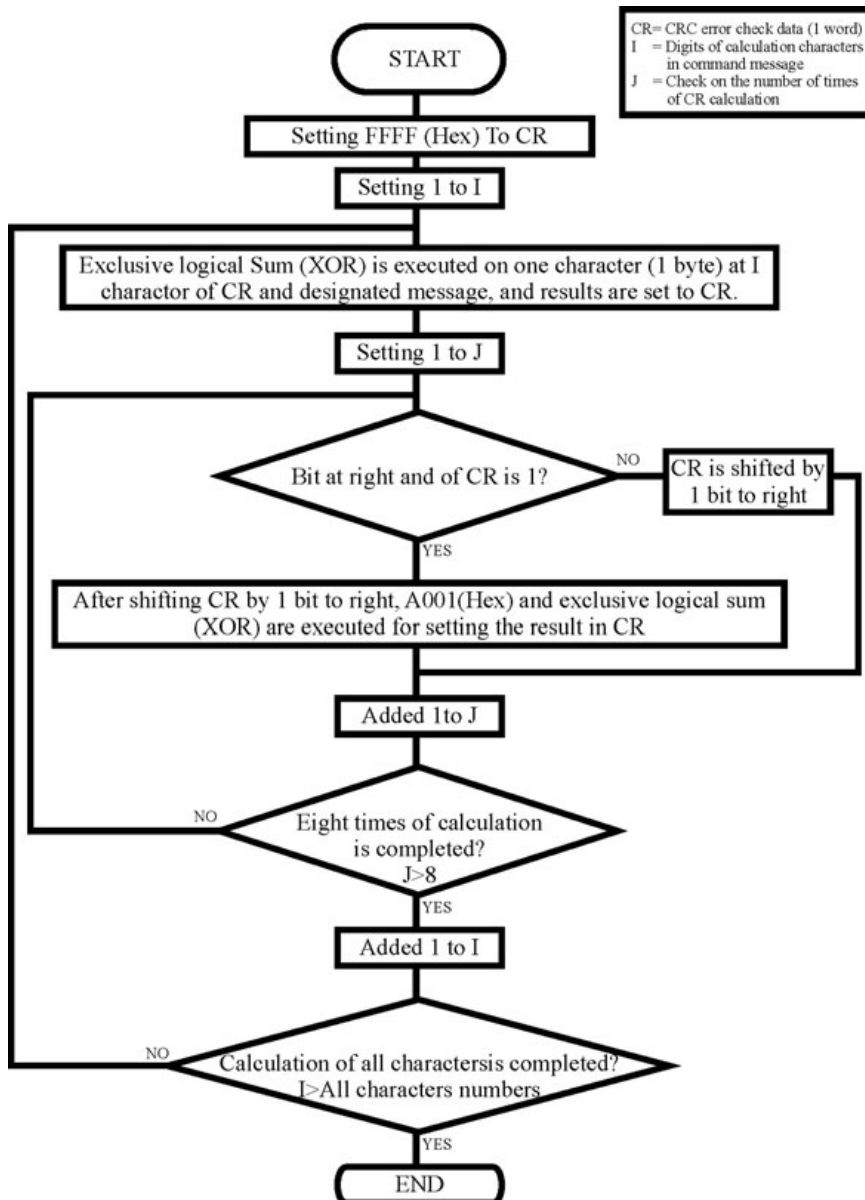

C Language CRC 16 Example

```

static short CRC16 (unsigned char *p_first,unsigned char *p_last)
{
    unsigned int crc=0xffff;
    short j;
    for (;p_first<=p_last;p_first++)
    {
        crc ^= *p_first;
        for(j=8;j>0;j--)
        {
            if(crc & 0x0001)
            {
                crc = crc >> 1;
                crc ^= 0xA001;
            }
            else
            {
                crc = crc >> 1;
            }
        }
    }
    return (crc);
}
  
```

12.3 Read Holding Registers

This function reads the instantaneous value of a specified number of parameters from an address. The message is composed by 8 Byte: one Byte is for the address, one for the function (03 Hex), two Byte for the first parameter to read, two Byte for the total number of parameters to read and finally two Byte for the CRC:

Address Unit	Function	Address of the First Parameter		N° of the Parameter		CRC 16	
		HI	LO	HI	LO	LO	HI
	3 3Hex						

The answer is an echo of the first two Byte (address and function), one byte with the number of following byte to exclusion of the CRC, the demanded values and finally two Byte for the CRC:

Address Unit	Function	N° of Byte	First Parameter Value		...	Last parameter value		CRC 16	
			HI	LO		HI	LO	LO	HI
	3 3Hex								

12.4 Preset Multiple Registers

This function could write only a parameter for each message.

The message is composed by 11 Byte: one Byte for the address, one for the function (10 Hex), two Byte for first parameter to write, two Bytes for the N° of parameters, fixed to 1 (0001 Hex), one Byte with the number of following Bytes, fixed to 2 (02 Hex), two Byte for the CRC:

Address Unit	Function	Address of the First Parameter		N° of the Parameter		N° of Byte	Value to write		CRC 16	
		HI	LO	0	1		2	HI	LO	LO
	16 10Hex									

The answer is an echo of the first two Byte (address and function), two Byte for first written parameter, two Byte with the N° of parameters, fixed to 1 (0001 Hex), two Byte for the CRC:

Address Unit	Function	Address of the First Parameter		N° of the Parameter		CRC 16	
		HI	LO	0	1	LO	HI
	16 10Hex						

12.5 Error and exception responses

If a message contains an altered character, if fails the CRC, or if the received message contains a syntax error (for example the number of the byte or of the words is not correct), then the unit will ignore the message.

If the received message is correct but contains a not valid value, the unit will send an answer of exception (5 byte):

Address Unit	Function	Error Code	CRC 16	
			LO	HI

The byte with the function number, represent the function number of the message that has caused the error with the first Bit set to 1 (ex. the function 3 becomes 0x83) The error code could be one of the followings:

Error Code	Name	Cause
1	ILLEGAL FUNCTION	Function not supported.
2	ILLEGAL DATA ADDRESS	Address out of range.
3	ILLEGAL DATA VALUE	Attempt to write invalid or action not carried out.



NOTE: If you write a parameter's value equal at his actual value this is a valid transaction and don't cause an error.

13 Configuration Parameters

The Configuration Parameters are accessible from the software configurator or through the serial communication port RS485.

P001L (H01)	Byte Lo = Load Voltage	R
Function:	This parameter show the Voltage rms value	
Min/Max:	0 ÷ 255 (0 ÷ FF Hex)	
Value:	Value depends on the Unit type	
P001H (H01)	Byte Hi = Load Current	R
Function:	This parameter shows the Current rms value.	
Min/Max:	0 ÷ 255 (0 ÷ FF Hex)	
Value:	Value depends of current transformer and from his size's.	
Example:	With current transformer (CT) 150/0.05A, the max value corresponds to the max value of the CT: Read value=255 (FF Hex) -> Load Current= 150A	
P002L (H02)	Byte Lo = Set-point Voltage	R/W
Function:	This parameter is the Set-point voltage saved by the Calibration Procedure	
Min/Max:	0 ÷ 255 (0 ÷ FF Hex)	
P002H (H02)	Byte Hi = Set-point Current	R/W
Function:	This parameter is the Set-point of current below which HB alarm occurs	
Min/Max:	0 ÷ 255 (0 ÷ FF Hex)	
Value:	This value is the load current(P001H) minus % value of parameter P126H	
P003 (H03)	Status Table	R
Function:	It's a tab in bit that represent the "Status" of thyristor unit	
Value:	Bit 0 = 1 -> Short circuit on SCR Bit 1 = 1 -> Load Failure (HB Alarm) Bit 2 = 1 -> Output signal ON Bit 3 = 1 -> HB Calibration in progress Bit 4 = 1 -> Current Limit Flag Bit 5 = 1 -> Thermal switch	
P004 (H04)	Command Table	R/W
Function:	It's a tab in bit for remote commands via RS485	
Value:	Bit 0 = 1 -> Activate HB Calibration procedure Bit 1 = 1 -> Input Command from RS485 (see P005) Bit 2 = 1 -> Disable Output signal (Only with Input from RS485) Bit 3 = 1 -> Reset HB Alarm Bit 4 = 1 -> Current Limit via RS485 (see P007)	
Note:	When unit is switch off all command parameter are set to 0	
P005L (H05)	Input command signal	R
Function:	This parameter reads the Input command signal (see par. 7.4) When the P004 Bit1 =1 This parameter could be written and become the Input Command from RS485	
Min/Max:	0 ÷ 255 (0 ÷ FF Hex)	
Example:	Input 4mA -> P005L = 0 (0%) Input 12mA -> P005L = 128 (50%) Input 20mA -> P005L = 255 (100%)	
P005H (H05)	Byte Hi = Ramped Input command signal	R
Function:	This parameter reads the Input command signal after the ramp	
Min/Max:	0 ÷ 255 (0 ÷ FF Hex)	
Example:	Input 4mA -> P005H = 0 (0%) Input 12mA -> P005H = 128 (50%) Input 20mA -> P005H = 255 (100%)	

P006 (H06)

Function:

Min/Max:

Value:

Note:

Power adjust

Its' a scaling factor of the Input command signal

0 ÷ 255 (0 ÷ FF Hex)

from 0 = 0% of Output,

To 255 = 100% of Output.

This parameter limit the Output Power

OUT %

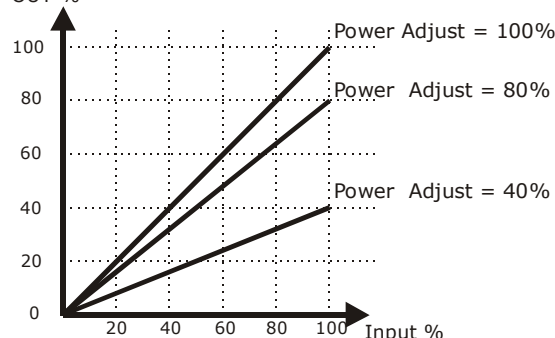
**R/W****P007 (H07)**

Function:

Min/Max:

Value:

Example:

Current Limit

This parameter show the Current Limit value (see par. 10.3)

When the P004 Bit4 =1 This parameter could be written and become the Current Limit from RS485

0 ÷ 255 (0 ÷ FF Hex)

Value depends of current transformer and from his size's.

With current transformer (CT) 150/0.05A, the max value corresponds to the max value of the CT:

Read value=255 (FF Hex) -> Load Current= 150A

R**P121 (H79)**

Function:

Value:

CD Unit ID

This parameter Identify the CD type Family

CD32 Hex = CD3200 Family

R**P122 (H7A)**

Function:

CD Ver

This parameter is for internal use

R**P123 (H7B)**

Function:

Min/Max:

Value:

Note:

Password

This parameter give the access to configuration

0 ÷ FFFF Hex

9357 Hex = Writing parameters activated

any value = Writing parameters disabled

When the unit comes out and then re-lighted, for change the parameters you must re-insert the password.

R/W**P124 (H7C)**

Function:

Min/Max:

Value:

Actual power

This parameter show the actual value of the power demand

0 ÷ 65535 (0 ÷ FFFF Hex)

from 0 = 0% output power,

to 65535 = 100% output power.

R

P125L (H7D)	Byte Lo = Feed-Back Type	R/W
Function:	This parameter set the Feed-Back Type	
Value:	00 Hex = V2 20 Hex = V 40 Hex = I 80 Hex = VxI	
Default:	20 (if not specified in the Order Code)	
P125H (H7D)	Byte Hi = Soft start time	R/W
Function:	The Unit starts in phase angle mode with a ramp starting from zero up to full voltage in a presettted and Adjustable time. The time is setted by this parameter	
Min/Max:	0 ÷ 255 (0 ÷ FF Hex)	
Value:	Each step is 50msec	
Default:	20 (S+PA)	
P126L (H7E)	Byte Lo = HB Delay time	R/W
Function:	This parameter set a delay to have HB alarm active	
Min/Max:	1 ÷ 255 (0 ÷ FF Hex)	
Value:	Each step is 50msec	
Default:	30 (if not specified in the Order Code)	
Note:	If Soft start option is enabled HB Delay time must be greater than Soft start time: P126L x 50msec > P125H x 50msec	
P126H (H7E)	Byte Hi = HB sensibility	R/W
Function:	This parameter is the maximum reduction of Load Current to establish the HB Alarm	
Min/Max:	0 ÷ 100 (0 ÷ 64 Hex)	
Value:	Each step is 1% from Nominal Current	
Default:	14 Hex	
Note:	When you change this parameter, HB Calibration procedure is necessary.	
P127 (H7F)	Power Set	R/W
Function:	This parameter show the Power set saved by the Calibration Procedure	
Min/Max:	0 ÷ 65535 (0 ÷ FFFF Hex)	
Value:	from 0 = 0% output power, to 65535 = 100% output power.	
P128L (H80)	Byte Lo = Integral	R/W
Function:	This parameter is the integral time of the feed-back loop	
Min/Max:	0 ÷ 255 (0 ÷ FF Hex)	
Default:	50 Hex	
Note:	If you increase integral time you increase the output stability, but you increase also the time to reach the set.	
P128H (H80)	Byte Hi = Proportional	R/W
Function:	This parameter is the gain of the feed-back loop	
Min/Max:	0 ÷ 255 (0 ÷ FF Hex)	
Default:	VxI or V2 = 5 Hex V or I = 12 Hex	
Note:	This parameter increase the loop speed but decrease the loop stability.	

14 Internal Fuse

The CD3200 thyristor unit have internal fuse extrarapid at low I^2t for the thyristor protection of against the short-circuits.

The fuse must have I^2t lower than the thyristor one (I^2t max)



Caution: USE ONLY EXTRARAPID FUSE WITH APPROPRIATE I^2t

14.1 Fuse Code

Size	200 kARMS Symmetrical A.I.C.				Qty
	Fuse CODE	Current (A RMS)	I^2T (A^2sec)	Vac	
125A (S09)	FU200FEE	200	11400	660	1
150A (S09)	FUURB250	250	52000	660	1
200A (S09)	FUURB315	315	82000	660	1
300A (S12)	FU350FMM	350	105000	660	1
400A (S12)	FU550FMM	550	215000	660	1
500A (S12)	FU700FMM	700	420000	660	1
600A (S12)	2xFU450FMM	900	420000	660	1
700A (S12)	2xFU450FMM	900	420000	660	1



Caution: The Fuses must have I^2t 20% less than thyristor's I^2t .



Caution: High speed fuses are used only for the thyristor protection and can not be used to protect the installation.



Caution: The warranty of thyristor is null if no proper fuses are used. See tab.



Warning: The user installation must be protected by electromagnetic circuit breaker or by fuse isolator.



15 Maintenance

15.1 Trouble Shooting

Small problems sometimes can be solved locally with the help of the below tab of trouble shooting. If you don't succeed, contact us or your nearest distributor.

Symptom	Indication on front unit	Possible reasons of the symptom	Actions
Thyristor unit doesn't go in conduction with input signal	Green LED (Aux) always light off	<ul style="list-style-type: none"> No voltage auxiliary power 	<ul style="list-style-type: none"> Give auxiliary voltage supply (see wiring diagram)
	Green LED (Aux) light on Green LED (ON) light off	<ul style="list-style-type: none"> No input signal Reversed polarities of input signal Reset contact is open 	<ul style="list-style-type: none"> Provide to give input signal Reverse the input signal polarity Make link on reset terminals (see wiring diagram)
	Green LED (Aux) light on Green LED (ON) light on	<ul style="list-style-type: none"> Fuse failure Load failure Load connection interruption Thyristor faulty and always in open circuit With HB option the yellow led (HB) is light on	<ul style="list-style-type: none"> Substitute the fuse Check the load Check the wiring Substitute the faulty thyristor
Load current flows also with no input signal	Green LED (ON) always light off.	<ul style="list-style-type: none"> Wrong wiring Short circuit on thyristor If there is HB option the red LED (SC) is light on	<ul style="list-style-type: none"> Check the load wiring Substitute the thyristor
Current flows at nominal value but Yellow LED (HB) is light on	Yellow LED (HB) light on	<ul style="list-style-type: none"> HB circuit not tuned Current transformers not properly wired 	<ul style="list-style-type: none"> Make HB calibration procedure Control current transformers wiring
Current flows at nominal value but Red LED (SC) is light on	Red LED (SC) light on	<ul style="list-style-type: none"> HB circuit not tuned 	<ul style="list-style-type: none"> Make HB calibration procedure
Thyristor unit doesn't work properly		<ul style="list-style-type: none"> Wrong input signal selection. Wrong input signal calibration (out of range). Auxiliary voltage supply out of limits 	<ul style="list-style-type: none"> Control input signal setting. Repeat input calibration procedure. Verify the auxiliary voltage supply

15.2 Fans

The thyristor unit with forced ventilation uses fans that rotate permanently when the unit is supplied. In case of fan failure, the heat-sink can reach high temperature. In this case to give protection to thyristor there is a thermal switch properly setted. The function of this switch is to open the input signal until the heat-sink temperature falls below the setted value. This means that also with input signal in ON condition the unit is switched OFF and the system can not work at full power. For this reason is important to control periodically the fans status checking that are rotating.

15.3 Maintenance

For maintain a correct cooling, the consumer must clean the heat-sink and the protective grate of the fans. The frequency of these operations depends on the atmospheric local pollution. Check also that the screw of the power terminals and earth terminals are shut correctly (see Diagram of control connection).

15.4 Repairing procedure

- Phone to CD Automation.
- Explain to Service Engineer the problem because sometimes it can be solved with a phone call. If this is not possible, ship the unit to CD Automation or to your distributor.
- Write a fault description and give the name of your personnel to which refers.
- Use a rugged packaging to ship the unit.

15.5 Warranty condition

CD Automation gives a 12 months warranty to its products. The warranty is limited to repairing and parts substitution in our factory and does exclude products not properly used and fuses. Warranty does not include products with serial numbers deleted. The faulty product should be shipped to CD Automation at customer's cost and our Service will evaluate if product is under warranty terms. Substituted parts remain of CD Automation property.