

LE-V50 Turbine
Installation & Operation Guide

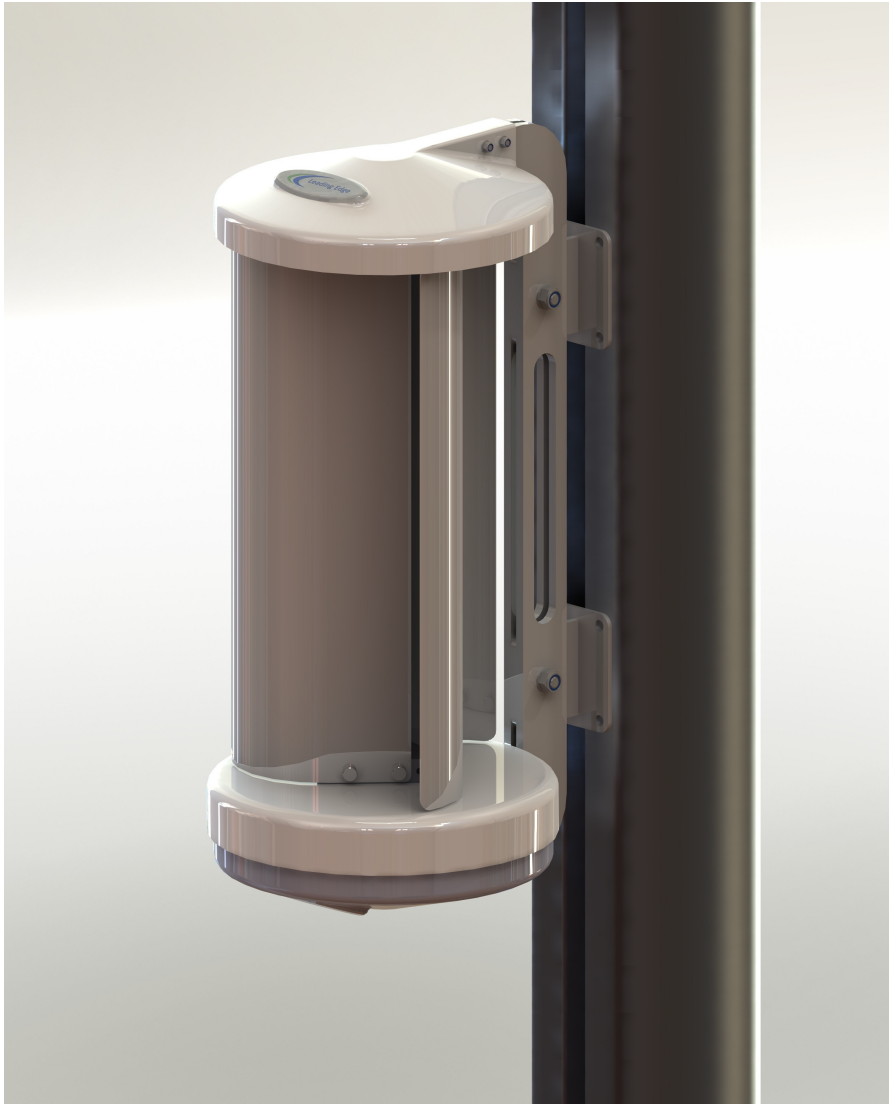

A micro vertical axis turbine for trickle charging and low power applications...

Leading Edge Turbines Ltd

Contents

Contents.....	2
Introduction	3
Safety Precautions	4
Specifications	5
Tools Required For Assembly	6
Mechanical Assembly Procedure.....	7
Electrical Installation.....	10
Turbine Operation	13
Maintenance	14
Spares.....	15
Warranty.....	16
Disclaimer.....	17

Warranty Registration

Please register your product with us so that we can administer your warranty entitlement.

Please register at www.leturbines.com/support/warranty-registration/

Customers are required to keep an original copy of their invoice should questions arise requiring reference to purchase information.

Introduction

Please read this manual thoroughly before attempting to assemble, install or operate your *LE-V50* small wind turbine. This will assure optimum performance and safety.

The *LE-V50* turbine features an array of innovations and construction techniques as well as heavy-duty engineering to ensure optimum efficiency and a long operating life.

The *LE-V50* has been designed to be simple, economic, durable and yield excellent performance.

Specific *LE-V50* turbine features:

- Innovatively designed axial flux alternator, using neodymium iron boron magnets
- Bearing support at both ends of the savonius rotor to provide stability and longevity
- Maintenance-free, low friction bearings
- Silent operation
- Easy installation
- Simple design for low cost and durability
- Fully marinised using stainless steel fixings and anodised aluminium components
- Low mass to help reduce exerted forces and ensure easy installation.

LE-V50 has been designed to for both land-based and marine environments. Thanks to its unique design, the *LE-V50* will suffer minimal corrosion in both normal and salt water operating conditions.

Applications include:

- Marine trickle charging
- Supplying power for DAQ and environmental monitoring
- Monitoring sites
- Telecommunications
- The Developing World.

Safety Precautions

Safety must always be your primary concern during the assembly, installation and operation of your *LE-V50* turbine. Always be aware of the risks involved with mechanical and electrical installation work. If in doubt about any issue regarding your turbine, please seek further assistance before proceeding. Installation of the *LE-V50* turbine should only be undertaken by suitably competent and qualified personnel.

Mechanical Safety Hazards

- The main rotor is the most obvious and serious mechanical safety risk. When the turbine is operating at its rated performance, the blades may be very difficult to see, due to the speed of rotation. Never approach the turbine whilst it is operating at speed. **Ensure that the turbine is installed in a suitable position where nobody can interfere with the rotor blades.**
- Working with tools of any kind can be dangerous. Your *LE-V50* turbine requires some basic mechanical assembly with rudimentary hand tools. If you are in any doubt about how to use these tools correctly, please seek advice from a suitably experienced person.
- Your *LE-V50* turbine will inevitably be installed upon a mast or tower or other support structure. This may mean working at height. Always ensure that all personnel in the immediate vicinity are aware of any lifting / hoisting operations that will be occurring. Check there are no loose components or tools likely to fall and cause injury during the lifting operation. Where possible, all assembly work should be completed at ground level.
- Ensure that the batteries are disconnected during the installation procedure.
- Twist the turbine output cables together (to create a short circuit) during the mechanical installation process. This will prevent the turbine from 'spinning up' during the installation.
- Never install the turbine upside down or in any orientation other than that depicted on the installation instructions.
- Install your turbine during a calm day.

Electrical Safety Hazards

- The *LE-V50* generates rectified DC voltage. Even at these low voltages there are inherent risks. Caution should always be used when connecting the *LE-V50* to the electrical system.
- Ensure that you have followed the cable-sizing chart to ensure that the correct size of transmission cable has been selected. If a cable of insufficient cross-sectional area is used, heat may build up in the cables causing a potential fire hazard. Using cables of insufficient cross-sectional area may also reduce the power transmission efficiency of the turbine.
- Battery systems can deliver a serious amount of current. A short circuit in the battery circuit can lead to hundreds of amps flowing through the battery cables. This will cause a heat build-up and ultimately an electrical fire. Batteries can explode when shorted. Always use insulated electrical tools when working on the battery's electrical connections.
- Batteries are very heavy. Do not attempt to move batteries by yourself. Always use manual handling tools and an assistant.
- Always keep lead-acid batteries the correct way up. Do not allow the acidic electrolyte to spill or come into contact with your skin or face. Always follow the manufacturer's safety instructions when handling lead-acid batteries.

Please use common sense when installing and operating your turbine!

Specifications

Turbine Name: *LE-v50 Turbine*
 Part Number: GA-LETU-010A
 Nominal Voltage: 12 / 24V / 48V DC

Rotor Diameter: 270 mm
 Rated Wind Velocity: 8 m/s
 Rated Output: 10 Watts
 Start-up Wind Velocity: 3 m/s
 Total weight: 9.0 Kg
 Tower mount: see below
 Chassis Construction: Aluminium
 Rotor Blades (3-off): Aluminium

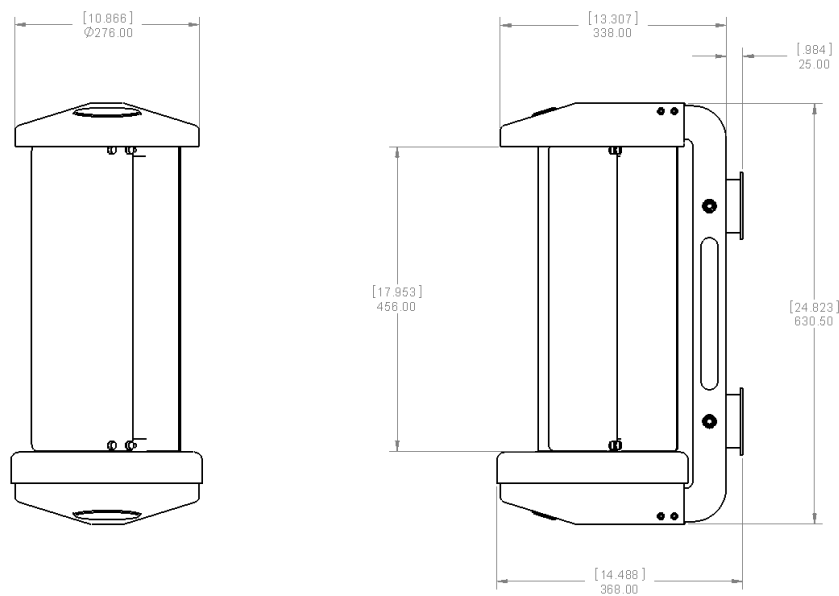

Fig-2: Operating Envelope

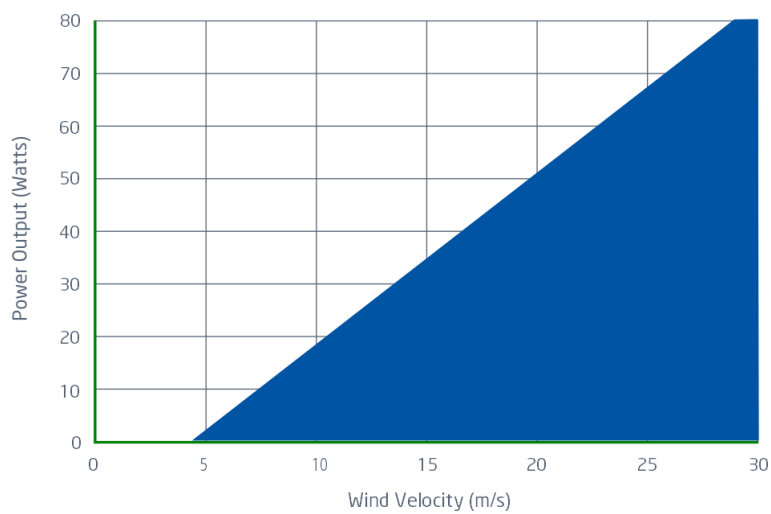
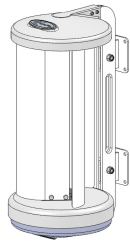

Fig-3: Energy Conversion

Package Contents

Your *LE-V50* turbine will arrive containing the components shown below. If any of the components are missing or damaged, please contact your dealer immediately.



LE-V50 Turbine: Qty 1



User Manual: Qty 1

Tools Required For Assembly

You will require the following tools to assemble your *LE-v50* turbine:

- 13 mm A/F spanner & 13 mm ratchet (one of each required)
- 8mm A/F spanner or ratchet
- A set of Metric Standard Hexagon Keys
- Electrical screw drivers
- Power drill
- 8.5 mm diameter twist drill bit, suitable for drilling through steel (if standard mount brackets are being used)
- Digital multi-meter capable of measuring DC Volts

Mechanical Assembly Procedure

- 1) **Unpacking** - Inspect the contents of the box and ensure that all items are present and free from damage. If any of the components are missing or damaged, please contact your dealer immediately.
- 2) **Check Main Rotor & Continuity** - Ensure that the main rotor is free turning and does not scrape or rub as it rotates - see Fig 4. As the turbine is shipped in a horizontal orientation, it may be the case that the upper or lower stub shafts or cowlings have shifted during transit.

If the turbine blades feel stiff and do not rotate freely, follow the below steps to reset the stub shaft positions:

- A) Remove the M5 cowling fixings and then the cowlings themselves.
- B) Slightly slacken the M5 fixings on the upper and lower stub shafts.
- C) Hold the turbine **vertically** and rotate the main rotor blades.
- D) The stub shafts will now reposition themselves and the turbine will rotate freely.
- E) Retighten the upper and lower stub shaft fixings and check that the turbine still rotates freely.
- F) Reposition and fix the cowlings ensuring that they do not rub upon each other..

The bearing units used in the magnet rotor assembly are factory lubricated and sealed for life. It will take approximately 100 hours of normal operation for the seals to 'bed-in' and the lubrication to be distributed correctly around the bearing raceways and ball cages. During this period you may notice a reduced performance caused by the additional friction of the bearing seals. In operating temperatures of -10 degrees Centigrade or lower, this 'bedding-in' period will be extended by a further 50 hours of normal operation.

Connect a digital multi-meter to the positive (red) and negative (black) output leads extending from the rear of the turbine. With the multi-meter set to detect DC Volts (0-20V), a voltage should be displayed when the main rotor is spun by hand. This voltage will vary with the speed of rotation. If no voltage is detected whilst turning the rotor, please contact your dealer immediately.

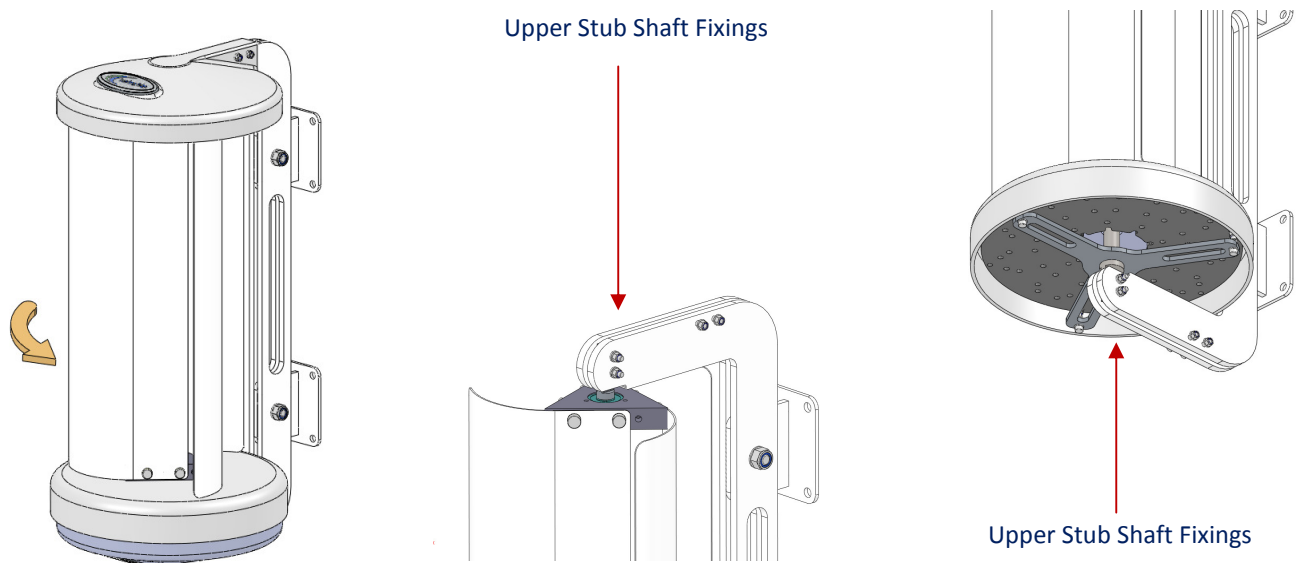
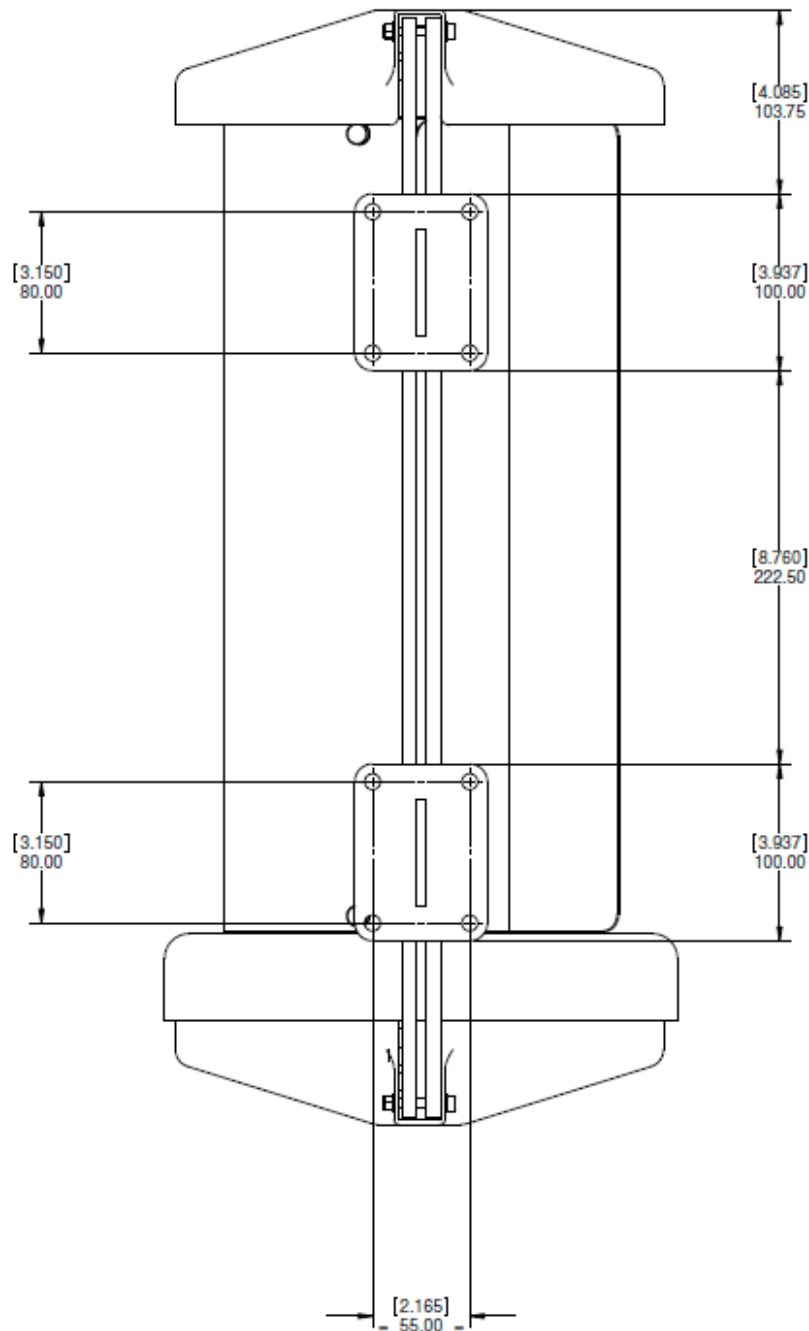

Fig-4: Checking main rotor rotation and voltage output

- 3) **Remove the turbine from the transit packing** – Use a pair of 13mm A/F spanner and or ratchet to remove the M8 fixings from the transit base board.
- 4) **Fix the turbine in its mounting Position** – With the turbine removed from the baseboard, it can now be fitted in its intended position. The LE-V50 is supplied as standard with two universal flat mounting brackets. Dimensions of the brackets can be found below in fig 5. Alternative mounting brackets are available from Leading Edge Turbines.

Ensure that the turbine is mounted vertically and on a flat and smooth surface. Incorrectly mounting the turbine may cause the main spine to distort which may result in the turbine not rotating freely.



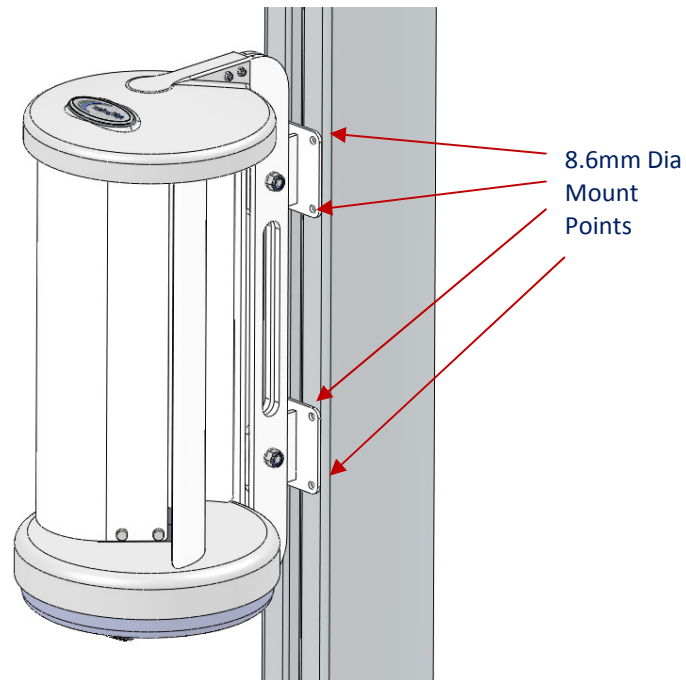

Fig-5: Mount the turbine in position

- 5) **Install the Transmission Cables-** Follow the table below to select the correct wire size (cross-sectional area). This will vary depending on your nominal battery voltage and the distance that the cables will be run. Careful selection of the cable size is required. It will not only affect the safety of the system, but also the overall efficiency. A cable of insufficient cable size will cause a voltage drop, wasting the power that has been generated. The cable sizes listed below have been selected with efficiency and cost in mind, as it is unlikely that your turbine will be running at full capacity 100% of the time. If in doubt, consult your local electrical supplier. The cable should be installed in accordance with local electrical regulations and guidelines. If in doubt, use a local electrical contractor to complete the cable installation. Once the transmission cable installed, it can be connected to the LE-V50.

Warning: If a cable of insufficient cross-sectional area is used, heat will build up in the cables causing a potential fire hazard. Cable capacities quoted below are based upon 'Tri-Rated' cables (BS6231).

LE-V50 Nominal Output Voltage	Transmission Distance		
	10 Metres (30 Feet)	30 Metres (90 Feet)	100 Metres (300 Feet)
12 Volts	1.5 mm ²	4 mm ²	Not Recommended
24 Volts	1.5 mm ²	2.5 mm ²	10 mm ²
48 Volts	1.5 mm ²	1.5 mm ²	4 mm ²

Electrical Installation

Please refer to Figs 6 for appropriate generic wiring diagrams. In a battery charging renewable energy system there may be different ways of wiring small wind turbines, photovoltaic panels, charge controllers and batteries together. This type of system will often expand ‘organically’, but the following guidelines should be followed:

- **Follow the appropriate electrical code** - The electrical wiring of your *LE-V50* turbine and associated electrical systems must be done in accordance with national and local electrical codes and regulations.
- **Do not connect the turbine or batteries during the installation** - Ensure that the turbine is not running or connected to the batteries during the installation or wiring process. Connect the output cables of the turbine together to prevent the rotor from starting up.
- **Galvanic corrosion of electrical joints** - Try to avoid connections between dissimilar metals. For example, connecting copper and aluminium together will result in galvanic corrosion of the connection. This will increase the electrical resistance of the connection (wasting energy), and reduce the mechanical integrity of the joint. Where possible, use a fluxed solder to make electrical joints.
- **Protect the cables** - The power transmission cables must be protected from mechanical damage and fatigue. Run the cables through an approved conduit / trunking.
- **Cable strain relief** - Prevent mechanical strain on the transmission cables running down the tower from the turbine. Clip the cables to the inside of the tower. Failure to do this will result in excessive mechanical strain on the cable joints within the slip-ring assembly and may cause a failure. Cable ties or cable glands are a good way to prevent mechanical strain on the cables.
- **‘Earth’ the System** - The turbine tower should have its own separate earth point. The negative terminal of the battery bank should also be earthed. This provides protection against the build-up of static and lightning strikes. The tower should be earthed separately with its own ground rod if there is a long transmission distance between the tower and batteries. An appropriate surge arrestor could also be used to help prevent damage to the battery charging system during a lightning strike. Ensure that the earth cables are of the same rating as the positive and negative cables.
- **Cable Selection** - The cable size table should be used to select the minimum sized cable for a given transmission distance. Voltage drop in the cable will be improved if a larger cable is used.
- **Fuses** - The turbine and charging circuit should be protected with a suitably rated ‘slow-blow’ DC fuse or DC circuit breaker. Please refer to the table below for the correct rating. The fuse or breaker should be positioned between the turbine and batteries (on the positive cable). If a stop switch is used (recommended) the fuse should be positioned between the switch and the batteries.

<i>LE-V50 Nominal Output Voltage</i>	<i>DC Fuse / DC Circuit Breaker Rating</i>
12V	6 Amp
24V	3 Amp
48V	1.5 Amp

- **Run / Stop Switch** - A simple switch arrangement can provide a safe and easy way of stopping the turbine during high winds, or for maintenance. *Leading Edge Turbines* can supply a switch which is best for this purpose. As the switch is thrown, the batteries are disconnected and the turbine is 'shorted' reducing the rotor to a slow rotation. Refer to the generic wiring diagrams. A run / stop switch is optional on the LE-V50 turbine. See Appendix for more information.
- **Charge Controllers** – Normally, the LE-V50 turbine does not require any external charge control equipment to be installed in the system. Due to the low Tip Speed Ratio of the turbine, the turbine output decreases naturally as the battery voltage increases – this provides a natural form of charge regulation. However, in extreme wind environments (such as arctic conditions) and special systems, it is possible to install a DL-300 charge controller. See Appendix for more information.
- **'Hybrid' Systems** - The *LE-V50* turbine can be used in parallel with PV panels. We recommend that the PV panels are wired independently with a separate charge controller specifically designed for use with them and connected in parallel with the battery bank.

Please refer to the following wiring diagrams as a guide.

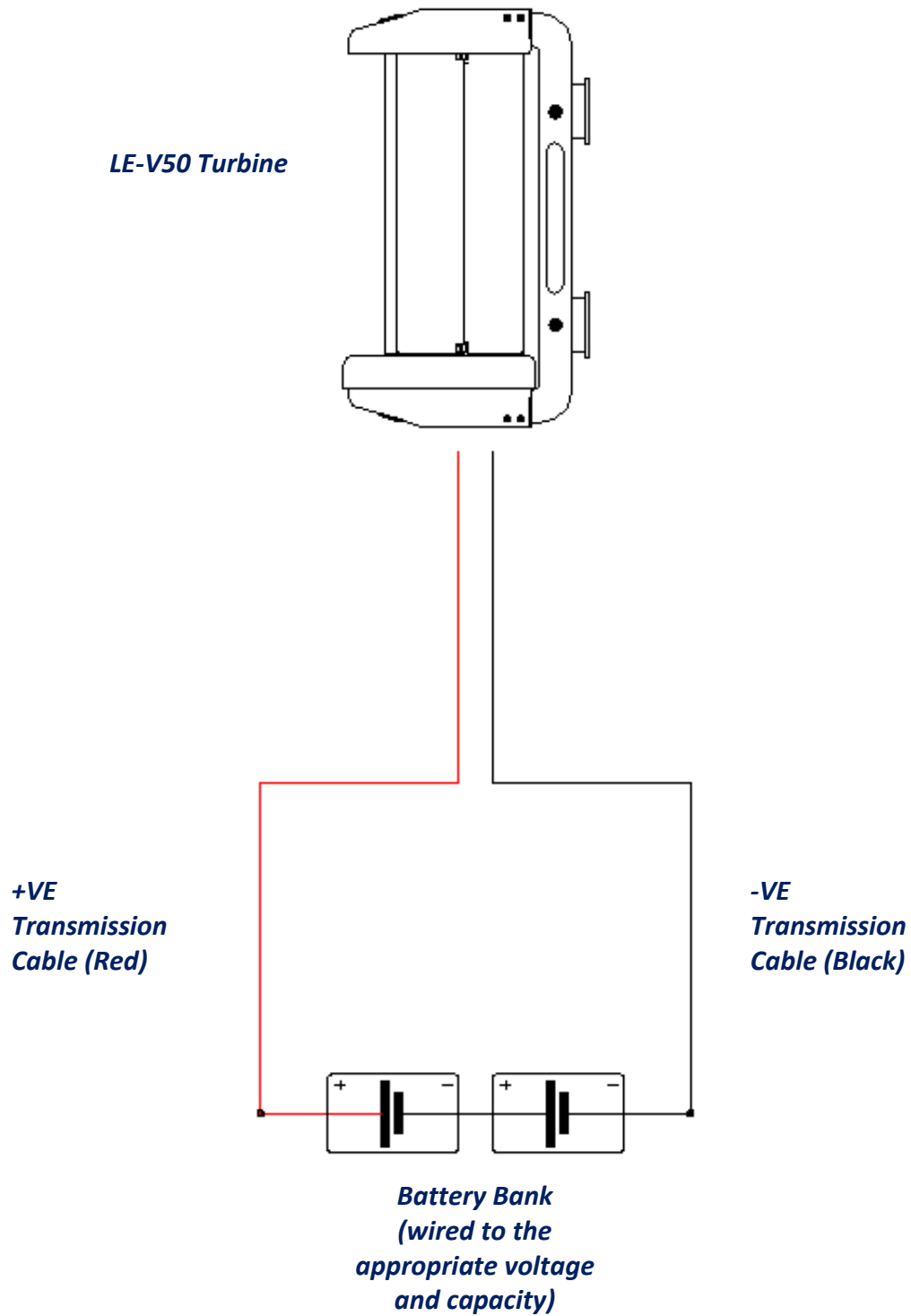

Fig-6: Simple 'Stand-Alone' battery-charging wiring diagram

Turbine Operation

The *LE-V50* turbine is based on a simple design for ease of installation and reliable operation. You may notice the following behaviour during normal operation:

- **Cut-in** - The turbine will not begin to charge the batteries until the rotor is spinning at approximately 120 RPM. Whilst operating below this speed, the turbine will be 'off-load' and freewheeling. Once the turbine output voltage becomes equal to the nominal battery voltage (at around 120 RPM), the turbine will come 'on-load' and begin to deliver current to the batteries. During the off-load stages of rotation, the rotor blades rotate very freely. This allows the rotor to build up speed and allows aerodynamic lift to be generated by the blades.
- **Normal Operation** - Once the rotor is spinning at 120 RPM, current will be delivered to the batteries. As the rotor speed increases, so too will the current and voltage.
- **Shut Down (If Run / Stop switch is fitted)** – A run / stop switch is not required with the *LE-V50* turbine but one can be installed if desired (see appendix 2). By activating the stop switch, the output cables of the turbine are 'shorted' together. This effectively puts an infinite load on the generator causing the turbine to stall. When the stop switch is activated the turbine may still rotate slowly during high winds, but the rotor blades will not be able to build up any significant speed. It is not recommended that the stop switch is activated whilst the rotor is spinning at high speed. This sudden braking action will stress the blades and other components. Only activate the stop switch during a 'lull' when the rotor is not spinning excessively fast.
- **High Winds** - Every effort has been taken to ensure that the *LE-V50* will withstand the forces exerted by strong winds. The turbine will continue to generate power whilst surviving the immense forces that are exerted by high winds.

Maintenance

Please follow the preventive maintenance programme listed below. This will ensure that the turbine operates reliably and safely with good efficiency.

Always shut down the turbine before attempting to carry out maintenance.

Post-Installation Checks (to be carried out one month after installation):

- Check that the turbine mount fixings are secure and has not worked loose. Adjust if required.
- Ensure that the rotor blades rotate freely.
- Ensure that all electrical connections are sound.

Annual Maintenance:

- Inspect the turbine & support structure.
- Ensure that the bearings are smooth and free running.
- Inspect the rotor blades for damage such as dents or chips. The blades will become unbalanced if they are damaged. This will cause vibration, noise and poor performance. If many dents have occurred along the edges of the blades, a new set of rotor blades should be fitted (part numbers available in the Spares section).
- Remove any build-up of dirt and debris from the rotor blades using a mild detergent and warm water.
- Check the blade fixings for tightness.
- Check that all electrical connections are sound and free from corrosion.
- Generally ensure that the turbine is in good working condition and is safe for continued use.

After five years of normal operation:

- We recommend that the rotor bearings should be replaced after five years of continuous operation. This will ensure that the turbine's performance and safety is not compromised.

Other Considerations:

- The equipment used in the charging system (batteries, charge controller, PV panels, invertors, etc.) should be maintained according to the instructions published by the relevant manufacturer.
- Where lead-acid batteries are used, it is especially important that they are maintained carefully. Failure to do so will result in the batteries being rendered useless within a short period of time.

Spares

The following components may need to be replaced during the service life of your *LE-V50* turbine. Please contact your nearest *Leading Edge Turbines' Dealer*, and quote the part numbers listed below.

Rotor Blade:	DP-LETU-145
Rotor Bearing Housing:	DP-LETU-198
Rotor Bearing:	OS-090
Stator (48VDC):	SA-LETU-006/48V
Stator (24 VDC):	SA-LETU-006/24V
Stator (12 VDC):	SA-LETU-006/12V
Bridge Rectifier:	OS-019
Run / Stop Switch Box:	GA-CTRL-008A
DL-300 Diversion Controller:	GA-CTRL-001A

Warranty

Your *LE-V50 turbine* carries a two-year warranty from the original purchase date, as supported by a retailer's receipt.

During the two years of the warranty period any component found to be defective in material or workmanship will, at the discretion of *Leading Edge Turbines*, be replaced or repaired at no charge.

For minor component failures, replacements may be sent directly to the customer / dealer for replacement. For more serious defects we may suggest a 'return-to-base' arrangement for replacement or repair. In all cases *Leading Edge Turbines* will take reasonable action to ensure customer satisfaction. You will always receive a warm, courteous service in or out of your warranty period.

Your turbine must be installed and operated in accordance with this guide and local codes. Failure to do so will result in this warranty becoming null and void. Any unauthorised modifications to the turbine design will void the warranty and may compromise the safety of the machine.

What is not covered by your warranty?

- Damage caused by the neglect of periodic maintenance in the manner recommended.
- Damage caused by repair or maintenance performed using methods not specified by *Leading Edge Turbines* or by non-authorised dealers of *Leading Edge Turbines* products.
- Damaged caused by the use of non-genuine parts, or from the use of liquid agents or lubricants in or on the turbine, tower or control equipment.
- Damage caused by operating the turbine in conditions outside of those specified in the Owners' Guide – including, but not limited to, allowing the turbine to run off-load.
- Damage caused by modifications to the turbine, tower or control equipment not approved by *Leading Edge Turbines*.
- Damage caused to the turbine, tower and control equipment by improper storage or transport.
- Damage caused by lightning strikes.
- Damage due to extremely high winds and storm conditions (60 mph+)
- Damage caused by flying debris.
- Aesthetic phenomena that do not affect performance.
- Damage caused by unsatisfactory installation of the turbine, tower and/or control equipment.
- Damage caused by unsatisfactory tower / support structure design.
- Damage caused by incorrect connection to external electrical equipment, or failure to observe current regulations concerning connection to external electrical networks, equipment or any other devices.

If you should experience a problem with your turbine, your first 'port-of-call' should be the reseller or installer from whom you purchased the product. They will be able to resolve the problem quickly and efficiently. If you are unable to contact the original reseller, then please contact us directly. Please quote the serial number of your turbine when dealing with warranty issues. The serial number can be found on the nameplate positioned on the underside of the chassis.

Disclaimer

- All specifications are subject to change without prior notice.
- The information given in this user manual is believed to be accurate and reliable. *Leading Edge Turbines* assumes no responsibility for omissions or inaccuracies.
- The user of this information and product assumes full responsibility and risk.
- The *LE-V50* turbine is a source of electrical power. It must be installed in accordance with local building and electrical regulations. Consult your local planning (zoning) office for details.
- The *LE-V50* turbine has moving parts that may cause injury due to poor installation and unsafe operation. *Leading Edge Turbines* assumes no responsibility for problems caused by unsafe or unsatisfactory installation or operation.

Designed & Manufactured in the UK by:
Leading Edge Turbines Ltd
Skyrrid Farm,
Pontrilas,
Hereford.
HR2 0BW
Tel: +44 (0)845 652 0396
www.leturbines.com



Compliant with
EN BS 61400-2: Safety of Small Wind

Appendix 1: DL-300 Charge Controller User Manual

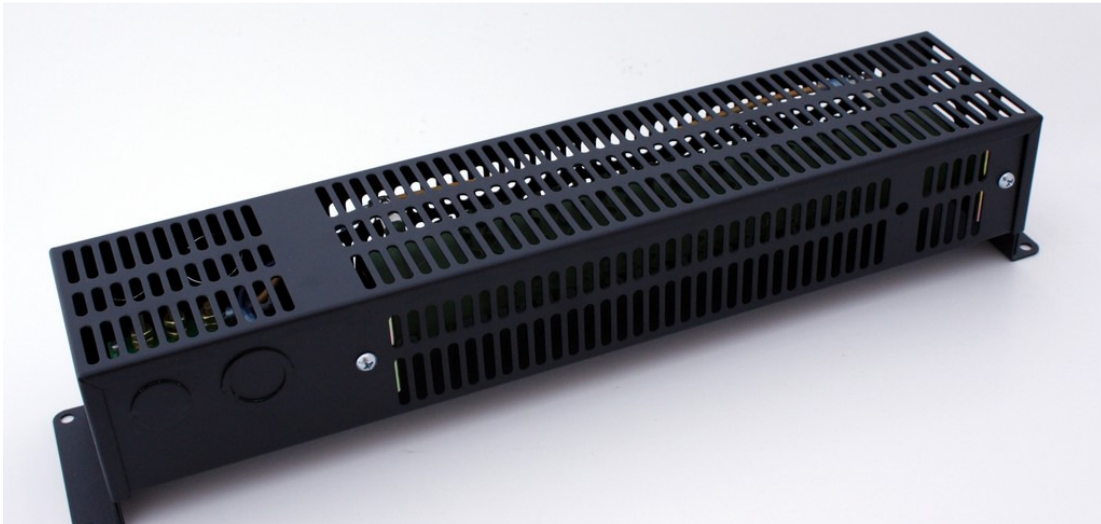

Introduction

Please read this manual thoroughly before attempting to assemble, install or operate your DL-300 Charge Controller. This will assure optimum performance and safety.

The DL-300 Series Dump Controller and Load is an integrated solution designed to prevent 12 or 24 Volt batteries from overcharging. It is designed to be used with small wind systems operating a LE-V50 turbine. Compact and easy to install, the DL-300 incorporates a 300 Watt resistor / heater and controller board in a stout powder coated steel enclosure.

Operation & Specification

As the LE-V50 turbine charges the batteries the State of Charge (SOC) and battery voltage will rise. Once the batteries reach full capacity, the dump load controller begins to bleed power from the turbine into the dump load. This energy is then dissipated as heat into the surrounding environment. More or less power is diverted to the dump load according to how much is being supplied to the battery and also in relation to the state of charge of the battery.

The DL-300 Features:

PWM (Pulse Width Modulation) for highest charging performance without flicker
Selectable three stage charging or over-voltage protection mode
Selectable for sealed or flooded batteries using jumpers

Power, 12 Volt version, DL300-12:

Recommend fuse or circuit breaker: 30 Amps
Integrated load resistor: 300 Watt, wire wound
Quiescent current when not load dumping: 2.6mA @ 12 Volts

Power, 24 Volt version, DL300-24:

Recommend fuse or circuit breaker: 15 Amps
Integrated load resistor: 300 Watt, wire wound
Quiescent current when not load dumping: 3.0mA @ 24 Volts

Connections:

#10-32 brass screws for V+ and V-
Two 1/2" / 3/4" concentric NPT knockouts and two 1/2" NPT knockouts

Mounting:

Mounts to vertical concrete, metal, drywall, or other non-flammable surface
Uses four #10 screws
Body sits 19 mm out from wall
Enclosure suitable for indoor mounting

Weight and Dimensions:

Dimensions: 88 mm wide, 95 mm tall, 470 mm long (3.375 x 3.75 x 18.5 in)
Weight: 1.94 Kg (4.28 pounds)
Shipping Dimensions: 102 mm wide, 108 mm tall, 508 mm long (4.0 x 4.25 x 20 in)
Shipping Weight: 2.15 Kg (4.75 pounds)

Materials:

Enclosure: 18 gauge mild steel, powder coated black
Circuit board: FR-4, 1.6 mm (0.062 in), double sided, plated through holes, solder mask, silk screen, gold plating
Hardware: stainless steel, zinc plated steel, aluminium, and Nylon

Safety Precautions

Safety must always be your primary concern during the assembly, installation and operation of your *LE-V50* turbine and DL300 charge controller. Always be aware of the risks involved with mechanical and electrical installation work. If in doubt about any issue regarding your turbine system, please seek further assistance before proceeding.

Mechanical Safety Hazards:

Whilst installing the DL300 charge controller or when performing routine inspection or maintenance, always stop the turbine by activating the stop switch.

Electrical Safety Hazards:

The *LE-V50* generates rectified DC voltage and the DL-300 controller also operates at these voltages. Even at these low voltages there are inherent risks. Caution should always be used when connecting an *LE-V50* turbine or DL-300 controller to the electrical system.

Ensure that you have followed the cable-sizing guidelines to ensure that the correct size of cable has been selected. If a cable of insufficient cross-sectional area is used at any point in the electrical system, heat will build up in the cables causing a potential fire hazard. A properly-sized fuse or circuit breaker should be used in the cables connected to the battery. This will stop the risk of short circuit currents.

Batteries used in renewable energy systems can deliver a serious amount of current. A short circuit in the battery circuit can lead to hundreds of Amps flowing through the battery cables. This will cause a heat build-up and ultimately an electrical fire. Batteries are also susceptible to explode when shorted. Always use insulated electrical tools when working on the battery's electrical connections.

Batteries are very heavy. Do not attempt to move batteries by yourself. Always use manual handling tools and an assistant.

Always keep lead-acid batteries the correct way up. Do not allow the acidic electrolyte to spill or come into contact with your skin or face. Always follow the manufacturer's safety instructions when handling lead-acid batteries.

Please use common sense when installing and operating your turbine and DL-300 Charge Controller

Electrical Installation

Please refer to electrical schematic for appropriate generic wiring diagrams. In a battery charging renewable energy system, there may be different ways of wiring small wind turbines, photovoltaic panels, charge controllers and batteries together. This type of system will often expand 'organically', but the following guidelines should be followed:

Location – The DL-300 controller should be mounted in an adequately ventilated area, which is not exposed to direct moisture or spray. The dump load elements become hot during normal operation and should not be covered or blocked.

Gel or Flooded Batteries – An electrical jumper needs to be configured in order to make the controller more suitable for use with 'Flooded' or 'Gel' batteries. A jumper (supplied) should be applied to pins labelled '2.2' when the DL-300 is to be used with flooded batteries. When the DL-300 is to be used with Gel batteries, no jumper should be applied to pins '2.2'. **In any circumstance, no jumper should be applied to pins '2.1'.**

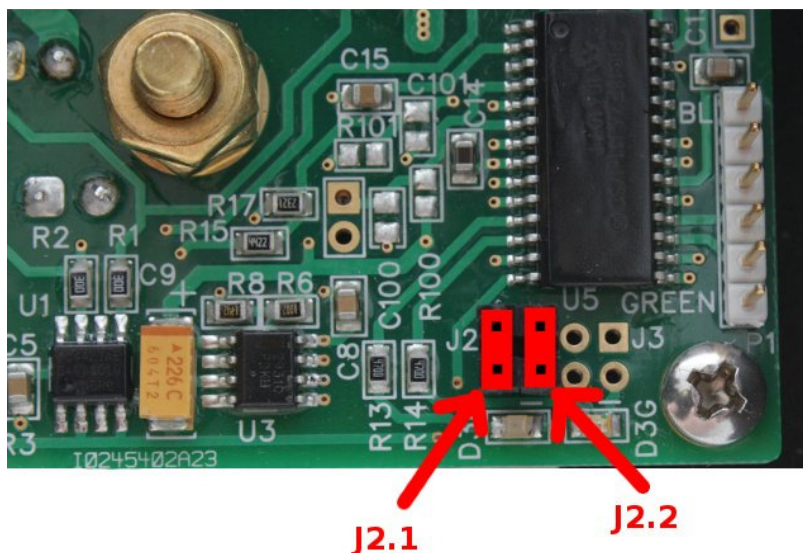

Use the correct voltage controller – A 12V DL300 controller should only be used on a 12V battery system. A 24V DL300 controller should only be used on a 24V battery system. Do not interchange.

Follow the appropriate electrical code - The electrical wiring of your *LE-V50* turbine and associated electrical systems must be done in accordance with national and local electrical codes and regulations.

Do not connect the turbine or batteries during the installation - Ensure that the turbine is not running or connected to the batteries during the installation or wiring process. Connect the output cables of the turbine together to prevent the rotor from starting up.

Galvanic corrosion of electrical joints - Try to avoid connections between dissimilar metals. For example, connecting copper and aluminium together will result in galvanic corrosion of the connection. This will increase the electrical resistance of the connection (wasting energy), and reduce the mechanical integrity of the joint. Where possible, use a fluxed solder to make electrical joints.

Protect the cables - The power transmission cables must be protected from mechanical damage and fatigue. Run the cables through an approved conduit / trunking.

Cable strain relief - Prevent mechanical strain on all cables. Cable ties or cable glands are a good way to prevent mechanical strain on the cables.

Fuses - The DL-300 controller should be protected with a suitably rated 'slow-blow' DC fuse or DC circuit breaker. Please refer to the table below for the correct rating. The fuse or breaker should be positioned between the DL300 and batteries (on the positive cable)

Nominal Voltage	DC Fuse / DC Circuit Breaker Rating
12V	30 Amp
24V	15 Amp

DL-300 Voltage Set Points

Whilst operating, the DL-300 does a multi-stage charge based on time and the bulk and float voltages:

12V Setpoints		
Mode	Flooded	Sealed
Bulk	14.6	14.3
Float	13.4	13.4
Protect	16.0	15.0

24V Setpoints		
Mode	Flooded	Sealed
Bulk	29.2	28.6
Float	26.8	26.8
Protect	32.0	30.0

LED Indicators

- Standby Mode (when first powered up):
 - both LEDs blink simultaneously every 7 seconds
- Charging Mode:
 - **bulk**: green blink - long delay - green blink
 - **absorb**: green blink - short delay - green blink
 - **float**: green solid
 - **dumping**: red solid when duty cycle > 0%

Appendix 2: Run / Stop Switch User Manual



Introduction

Please read this manual thoroughly before attempting to assemble, install or operate your Universal Run / Stop Switch. This will assure optimum performance and safety.

The Universal Run / Stop Switch is designed to allow the user to dynamically brake a *LE-V50* turbine or *LE-V50* turbine at will. This is achieved by disconnecting the power output of the turbine from the relevant load and diverting it to a short circuit which then applies the dynamic braking effect on the permanent magnet alternator of the turbine. This will bring the turbine to a near stop for maintenance or to allow the turbine to ride out high winds and storms safely.

The Universal Run / Stop Switch can be used with turbines of different manufacture as long as the relevant turbine has the following characteristics:

3-Phase Wild AC not exceeding 500 V & 16 A
Wild DC not exceeding 150 V & 10 A
Mechanically and electrically capable of dynamic braking

Operation & Specification

The Universal Run / Stop Switch should ideally be operated during low speeds as repeated use at high speeds may cause damage if the turbine head (it was not designed to withstand repeated dynamic braking operations).

The switch has two positions:

Position 1: Turbine 'Stop' position. The turbine is dynamically braked and may be seen to rotate very slowly.

Position 2: Turbine 'Run' position. The turbine output is allowed to flow straight through the switch to the relevant output.

Safety Precautions

Safety must always be your primary concern during the assembly, installation and operation of your turbine and other associated equipment. Always be aware of the risks involved with mechanical and electrical installation work. If in doubt about any issue regarding your turbine system, please seek further assistance before proceeding.

Mechanical Safety Hazards:

Whilst installing the Universal Run / Stop Switch, ensure that the turbine is suitable restrained and not allowed to operate during the installation.

Electrical Safety Hazards:

The *LE-V50* generates rectified DC voltage and the Universal Run / Stop Switch also operates at these voltages. Even at these low voltages there are inherent risks. Caution should always be used when connecting the *LE-V50* or other equipment to the electrical system. The *LE-V50* generates high voltage AC and the Universal Run / Stop Switch also operates at these voltages. At these high voltages there are significant risks. Caution should always be used when connecting an *LE-V50* or other equipment to the electrical system.

Ensure that you have followed the cable-sizing guidelines to ensure that the correct size of cable has been selected. If a cable of insufficient cross-sectional area is used at any point in the electrical system, heat will build up in the cables causing a potential fire hazard. A properly-sized fuse or circuit breaker should be used in the cables connected to the battery. This will stop the risk of short circuit currents.

Batteries used in renewable energy systems can deliver a serious amount of current. A short circuit in the battery circuit can lead to hundreds of Amps flowing through the battery cables. This will cause a heat build-up and ultimately an electrical fire. Batteries are also susceptible to exploding when shorted. Always use insulated electrical tools when working on the battery's electrical connections.

Batteries are very heavy. Do not attempt to move batteries by yourself. Always use manual handling tools and an assistant. Always keep lead-acid batteries the correct way up. Do not allow the acidic electrolyte to spill or come into contact with your skin or face. Always follow the manufacturer's safety instructions when handling lead-acid batteries. Ensure that the Universal Run / Stop switch is correctly wired as per these instructions and wiring schematics. Incorrect wiring may lead to a short circuit being placed across the batteries which can lead to fire or explosion.

Please use common sense when installing and operating your turbine and associated equipment.

Installation

Please refer to electrical schematic for appropriate generic wiring diagrams.

The Universal Run / Stop Switch can either be mounted in the enclosure box (supplied), which in turn can be mounted on an internal panel, or the switch can be integrated into an existing panel. If the unit is to be integrated into an existing panel, a suitable cut-out, as detailed on the wiring diagram will need to be made.

Switch Wiring for LE-V50 turbine:

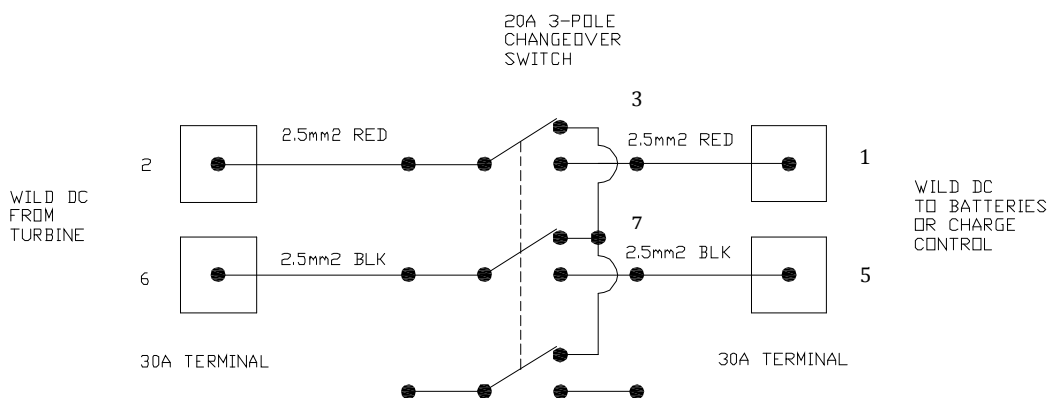

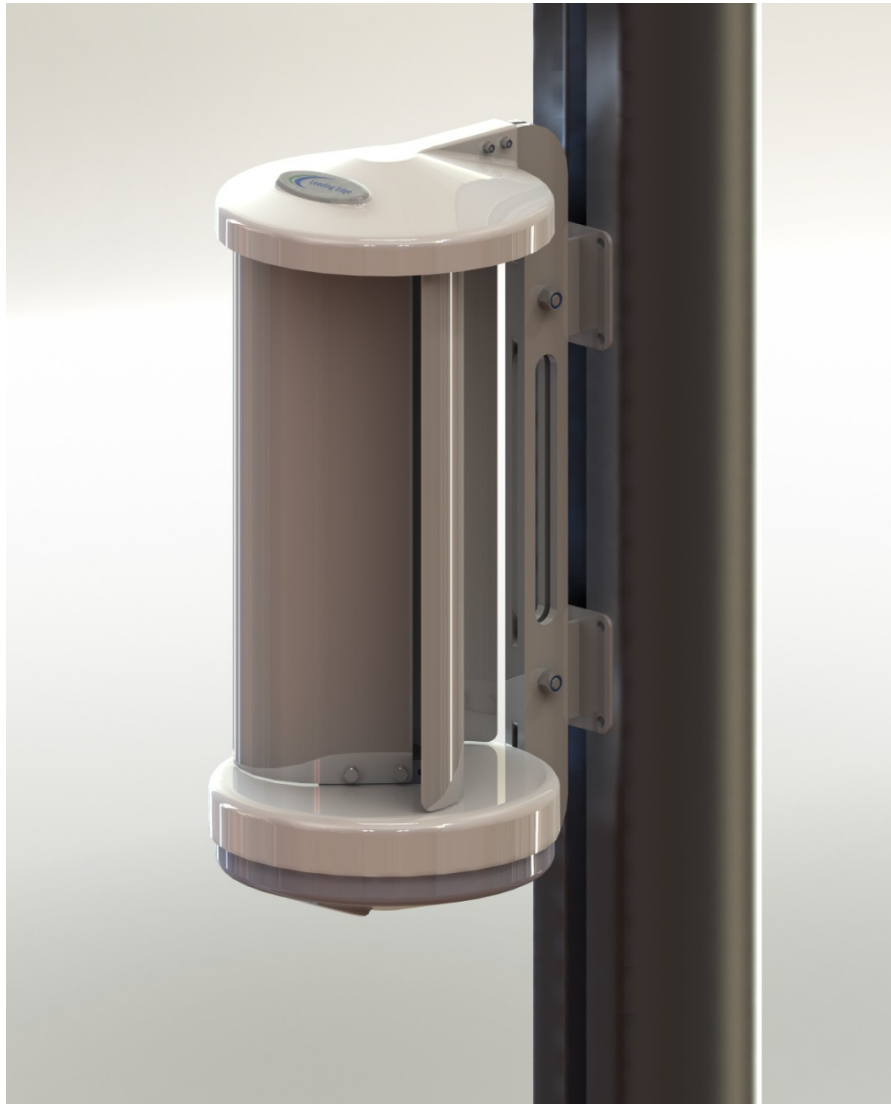

Leading Edge Turbines Ltd

Skyrrid Farm
Pontrilas
Hereford
HR2 0BW
UK

UK - 0845 652 0396 Outside UK- +44 1981 241 668
info@leturbines.com
www.leturbines.com



Contact Us
Leading Edge Turbines Ltd
 Skyrrid Farm
 Pontrilas
 Hereford
 HR2 0BW
 UK

UK - 0 845 652 0396 Outside UK- +44 1981 241 668
 info@leturbines.com
 www.leturbines.com

Your Local Distributor

