

Formula-X Chop

GC-1402F

ENG

***Low emission external-mix dispense gun for use with polyester resin and gel coat.
For professional use only.***

Maximum fluid working pressure:
2000 psi (14 MPa, 138 bar)

Maximum air pressure:
100 psi (0.7 MPa, 7 bar)



Important Safety Instructions

Read all warnings and instructions in this manual. Save these instructions.

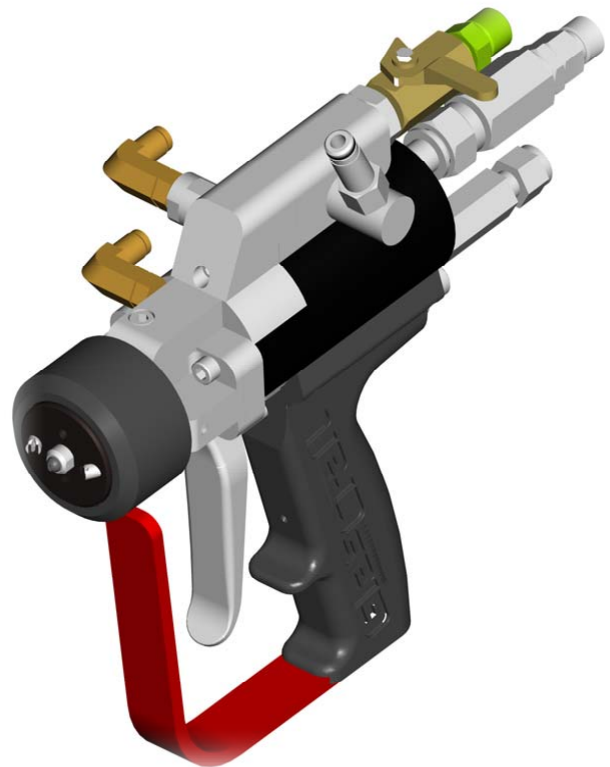





Contents

Warnings	3
Important Safety Information	5
Grounding	6
Set-Up.....	7
Parts	8
Assembly Drawings	9
Pressure Relief Procedure	12
Maintenance.....	13
Technical Data.....	18
Graco Ohio Standard Warranty.....	20
Graco Ohio Information	20





Warnings

The following warnings are for the setup, use, grounding, maintenance, and repair of this equipment. The exclamation point symbol alerts you to a general warning and the hazard symbol refers to procedure-specific risk. Refer back to these warnings. Additional, product-specific warnings may be found throughout the body of this manual where applicable.

- See Important Safety Information - MEKP, Polyester Resins and Gel-Coats and Spraying and Lamination Operations section of this manual.

 WARNING	
	<p>FIRE AND EXPLOSION HAZARD Flammable fumes, such as solvent and paint fumes, in work area can ignite or explode. To help prevent fire and explosion:</p> <ul style="list-style-type: none"> • Use equipment only in well ventilated area. • Eliminate all ignition sources; such as pilot lights, cigarettes, portable electric lamps, and plastic drop cloths (potential static arc). • Keep work area free of debris, including solvent, rags and gasoline. • Do not plug or unplug power cords, or turn power or light switches on or off when flammable fumes are present. • Ground all equipment in the work area. See Grounding instructions. • Use only grounded hoses. • Hold gun firmly to side of grounded pail when triggering into pail. • If there is static sparking or you feel a shock, stop operation immediately. Do not use equipment until you identify and correct the problem. • Keep a working fire extinguisher in the work area.
	<p>PERSONAL PROTECTIVE EQUIPMENT You must wear appropriate protective equipment when operating, servicing, or when in the operating area of the equipment to help protect you from serious injury, including eye injury, inhalation of toxic fumes, burns, and hearing loss. This equipment includes but is not limited to:</p> <ul style="list-style-type: none"> • Protective eyewear • Clothing and respirator as recommended by the fluid and solvent manufacturer • Gloves • Hearing protection
	<p>TOXIC FLUID OR FUMES HAZARD Toxic fluids or fumes can cause serious injury or death if splashed in the eyes or on skin, inhaled, or swallowed.</p> <ul style="list-style-type: none"> • Read MSDS's to know the specific hazards of the fluids you are using. • Store hazardous fluid in approved containers, and dispose of it according to applicable guidelines. • Always wear impervious gloves when spraying or cleaning equipment.

Warnings

 WARNING	
	<p>SKIN INJECTION HAZARD High-pressure fluid from gun, hose leaks, or ruptured components will pierce skin. This may look like just a cut, but it is a serious injury that can result in amputation. Get immediate surgical treatment.</p> <ul style="list-style-type: none"> • Do not point gun at anyone or at any part of the body. • Do not put your hand over the dispense outlet. • Do not stop or deflect leaks with your hand, body, glove, or rag. • Engage trigger lock when not spraying. • Follow Pressure Relief Procedure in this manual, when you stop spraying and before cleaning, checking, or servicing equipment.
	<p>EQUIPMENT MISUSE HAZARD Misuse can cause death or serious injury.</p> <ul style="list-style-type: none"> • Do not operate the unit when fatigued or under the influence of drugs or alcohol. • Do not exceed the maximum working pressure or temperature rating of the lowest rated system component. See Technical Data in all equipment manuals. • Use fluids and solvents that are compatible with equipment wetted parts. See Technical Data in all equipment manuals. Read fluid and solvent manufacturer's warnings. For complete information about your material, request MSDS forms from distributor or retailer. • Check equipment daily. Repair or replace worn or damaged parts immediately with genuine manufacturer's replacement parts only. • Do not alter or modify equipment. • Use equipment only for its intended purpose. Call your distributor for information. • Route hoses and cables away from traffic areas, sharp edges, moving parts, and hot surfaces. • Do not kink or over bend hoses or use hoses to pull equipment. • Keep children and animals away from work area. • Comply with all applicable safety regulations.
	<p>PRESSURIZED ALUMINUM PARTS HAZARD Do not use 1,1,1-trichloroethane, methylene chloride, other halogenated hydrocarbon solvents or fluids containing such solvents in pressurized aluminum equipment. Such use can cause serious chemical reaction and equipment rupture, and result in death, serious injury, and property damage.</p>

Important Safety Information

Methyl Ethyl Ketone Peroxide (MEKP)

MEKP is among the more hazardous materials found in commercial channels. Proper handling of the “unstable (reactive)” chemicals presents a definite challenge to the plastics industry. The highly reactive property which makes MEKP valuable to the plastics industry in producing the curing reaction of polyester resins and gel-coats also produces the hazards which require great care and caution in its storage, transportation, handling, processing and disposal.

Workers must be thoroughly informed of the hazards that may result from improper handling of MEKP, especially in regards to contamination and heat. They must be thoroughly instructed regarding the proper action to be taken in the storage, use and disposal of MEKP and other hazardous materials used in the laminating operation.



MEKP is flammable and potentially explosive, as well as potentially damaging to the eyes and skin.

Read material manufacturer’s warnings and material MSDS to know specific hazards and precautions related to MEKP.

Contaminated MEKP can become explosive. Prevent contamination of MEKP with other materials, which includes, but is not limited to polyester overspray, polymerization accelerators and promoters, and non-stainless metals. Even small amounts of contaminants can make MEKP explosive. This reaction may start slowly, and gradually build-up heat, which can accelerate until fire or an explosion result. This process can take from seconds to days.

Heat applied to MEKP, or heat build-up from contamination reactions can cause it to reach what is called its Self-Accelerating Decomposition Temperature (SADT), which can cause fire or explosion.

Spills should be promptly removed, so no residues remain. Spillage can heat up to the point of self-ignition. Dispose in accordance with manufacture’s recommendation.

Store MEKP in a cool, dry and well-ventilated area in the original containers away from direct sunlight and away from other chemicals. It is strongly recommended that the storage temperature remain below 86° F (30° C). Heat will increase the potential for explosive decomposition. Refer to NFPA 432. Keep MEKP away from heat, sparks and open flames.

Current catalysts are premixed and do not require any diluents. GlasCraft strongly recommends that diluents not be used. Diluents add to the possibility of contaminants entering the catalyst system. Never dilute MEKP with acetone or any solvent since this can produce an extremely shock-sensitive compound which can explode.

Use only original equipment or equivalent parts from GlasCraft in the catalyst system (i.e.: hoses, fittings, etc.) because a hazardous chemical reaction may result between substituted parts and MEKP.

To prevent contact with MEKP, appropriate personal protective equipment, including chemically impermeable gloves, boots, aprons and goggles are required for everyone in the work area.

Polyester Resins and Gel-Coats

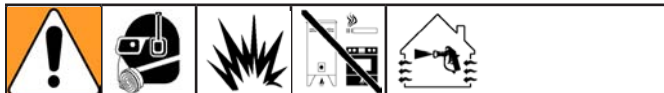

Spraying materials containing polyester resin and gel-coats creates potentially harmful mist, vapors and atomized particulates. Prevent inhalation by providing sufficient ventilation and the use of respirators in the work area.

Read the material manufacturer’s warnings and material MSDS to know specific hazards and precautions related to polyester resins and gel-coats.

To prevent contact with polyester resins and gel-coats, appropriate personal protective equipment, including chemically impermeable gloves, boots, aprons and goggles are required for everyone in the work area.

Spraying and Lamination Operations



Remove all accumulations of overspray, FRP sandings, etc. from the building as they occur. If this waste is allowed to build up, spillage of catalyst is more likely to start a fire.

If cleaning solvents are required, read material manufacturer’s warnings and material MSDS to know specific hazards and precautions. (GlasCraft recommends that clean-up solvents be nonflammable.)



GlasCraft recommends that you consult OSHA Sections 1910.94, 1910.106, 1910.107 and NFPA No. 33, Chapter 16,17, and NFPA No. 91 for further guidance.

Grounding



This equipment needs to be grounded.

Ground the dispense gun through connection to a GlasCraft approved grounded fluid supply hose.

Check your local electrical code and related manuals for detailed grounding instructions of all equipment in the work area.



A grounding wire and clamp are provided, assembly p/n 17440-00 with all FRP equipment.

Set-Up

Hose Attachment

1. Push in and rotate the trigger lock to stop the trigger from being activated.

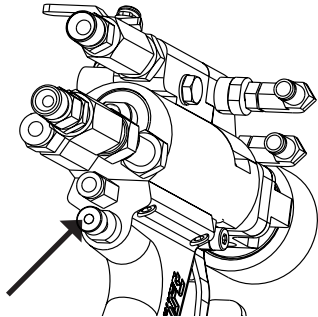

2. Attach the (black p/n 21694-25) material hose to the material inlet fitting on the back of the gun.

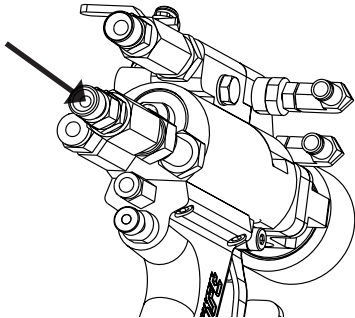

3. Attach the (red) atomize air tubing to the atomize air inlet fitting on the back of the gun.

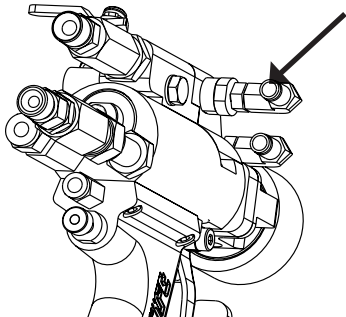

4. Attach the (stainless steel p/n 20190-00) catalyst hose to the catalyst inlet fitting on the back of the gun.

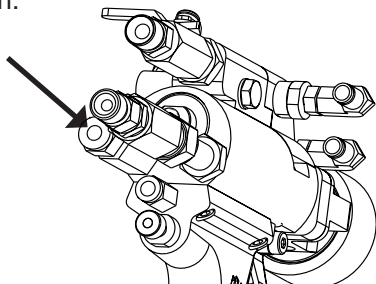

5. Attach the (Clear) trigger air tubing to the trigger air inlet fitting on the back of the gun.

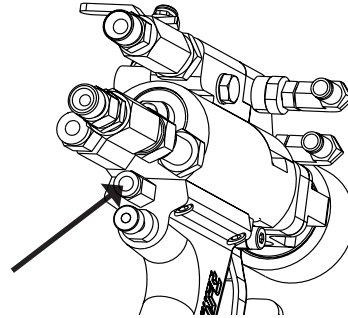

6. Attach the (black) AAC air tubing to the AAC air inlet fitting on the side of the gun.

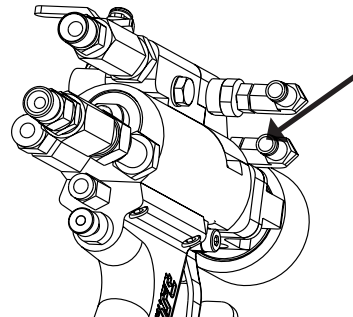

7. Attach the (Red) air hose to the chopper air inlet fitting on the side of the gun.

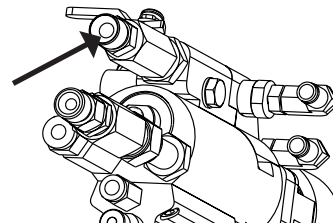

8. Spray head assembly

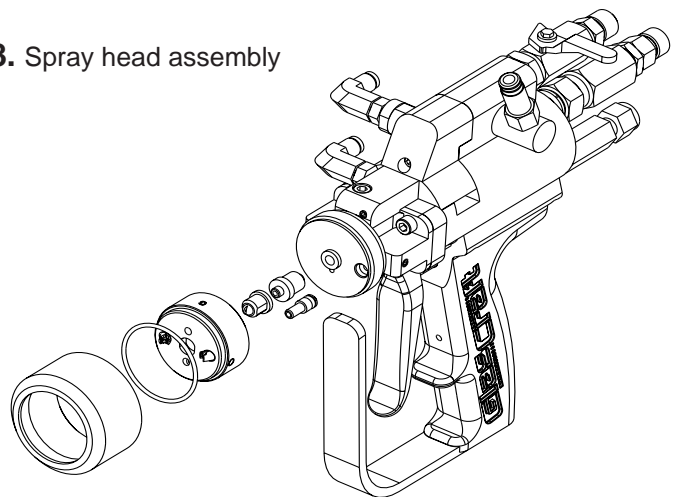

 See gun assy. drawings for part numbers and descriptions.

Parts

Formula X Chop Dispense Gun 23750-03

Standard Equipment	
Part Number	Description
23750-03	FORMULA X CHOP DISPENSE GUN
GC-1402	USER MANUAL

Repair Kits	
Part Number	Description
23792-00	GUN AIR KIT
23793-00	GUN SEAL KIT
23732-00	GUN FLUID VALVE KIT

Assembly Drawings

23750-03 Formula X Chop Dispense Gun

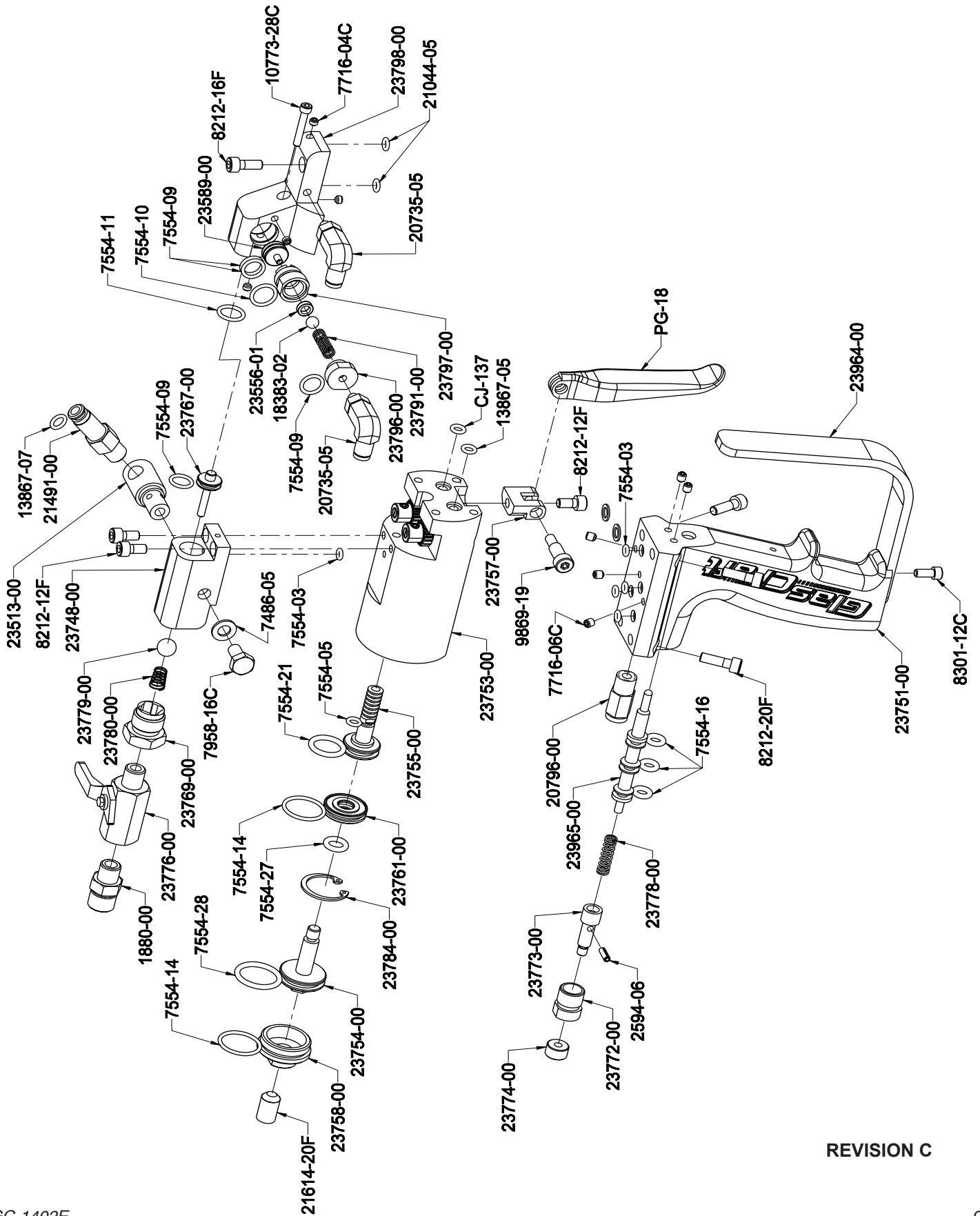

REVISION C

Assembly Drawings

23750-03 Formula X Chop Dispense Gun

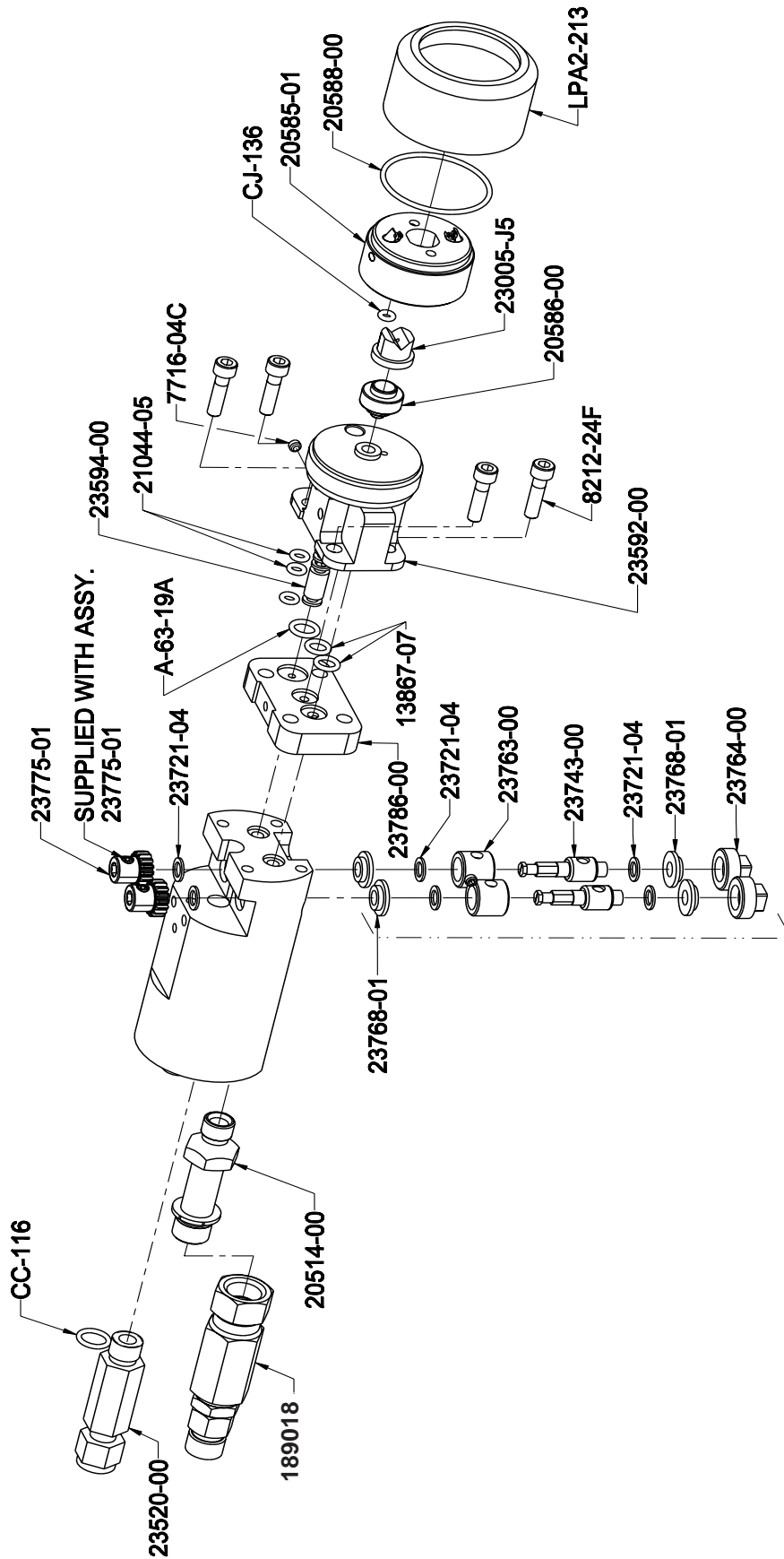

REVISION C

Assembly Drawings

23750-03 Formula X Chop Dispense Gun

Part Number	Description	Qty.
10773-28C	SCREW	1
13867-05	O-RING	1
13867-07	O-RING	3
15845-01	5/32in. BALL DRIVER	1
18383-02	1/4in. DIA. SST BALL	1
1880-00	FITTING	1
20514-00	FITTING	1
20585-01	CATALYST RING	1
20586-00	NOZZLE SEAL	1
20588-00	RETAINING SEAL	1
20735-05	ELBOW FITTING	2
20796-00	FITTING	1
21044-05	O-RING	5
21491-00	TUBE CUTTER	1
21614-20F	SET SCREW	1
23005-J5	20/50 SPRAY TIP	1
23513-00	CHOPPER ROTATING MOUNT	1
23520-00	FITTING	1
23556-01	WASHER	1
23589-00	AIR SHIFTER	1
23592-00	FRONT HEAD	1
23594-00	AIR ASSIST INSERT	1
189018	FITTING	1
23721-04	PACKING DISK	6
23748-00	CHOPPER MOUNT	1
23751-00	GUN HANDLE	1
23753-00	GUN BODY	1
23754-00	AIR PISTON	1
23755-00	AIR PISTON	1
23757-00	HANDLE ADAPTER	1
23758-00	REAR CAP	1
23761-00	CYLINDER SPACER	1
23762-00	FLUID VALVE	2
23763-00	SEAL	2
23764-00	PACKING NUT	2
23767-00	CHOPPER PISTON	1
23768-00	BEARING	4
23769-00	ADAPTER	1
23772-00	TRIGGER STOP	1
23773-00	TRIGGER STOP INSERT	1
23774-00	TRIGGER STOP CAP	1
23775-00	GEAR	2

Part Number	Description	Qty.
23776-00	BALL VALVE	1
23778-00	COMPRESSION SPRING	1
23779-00	STEEL BALL	1
23780-00	TAPERED SPRING	1
23784-00	RETAINING RING	1
23786-00	EXTERNAL ADAPTER	1
23791-00	COMPRESSION SPRING	1
23792-00	AIR GUN KIT	1
23793-00	SEAL KIT	1
23796-00	THREADED INSERT	1
23797-00	AIR SHIFTER	1
23798-00	CHOP HEAD	1
23964-00	GUARD	1
23965-00	TRIGGER PISTON	1
2594-06	ROLL PIN	1
7486-05	WASHER	1
7554-03	O-RING	5
7554-05	O-RING	1
7554-09	O-RING	4
7554-10	O-RING	1
7554-11	O-RING	1
7554-14	O-RING	2
7554-16	O-RING	3
7554-21	O-RING	1
7554-27	O-RING	1
7554-28	O-RING	1
7716-04C	SET SCREW	5
7716-06C	SET SCREW	5
7958-16C	SCREW	1
8212-12F	SCREW	3
8212-16F	SCREW	1
8212-20F	SCREW	4
8212-24F	SCREW	4
8301-12C	SCREW	1
9869-19	SHOULDER SCREW	1
9936-04F	SET SCREW	2
A-63-19A	O-RING	1
CC-116	O-RING	1
CJ-136	O-RING	1
CJ-137	O-RING	1
LPA2-213	END CAP	1
PG-18	TRIGGER	1

REVISION C

Pressure Relief Procedure



To relieve fluid and air pressures:

1. Push down Yellow slide valve, P/N 21402-00 to bleed off air to system.

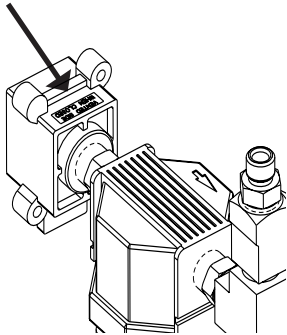

2. Open P/N 21228-00 on catalyst pump to recirculation position.

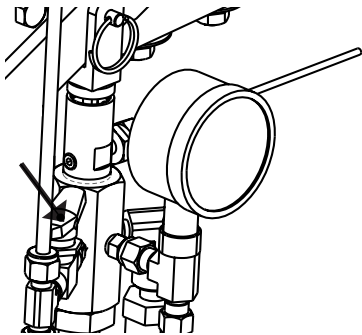

3. Open P/N 21192-00 on bottom of material pump.

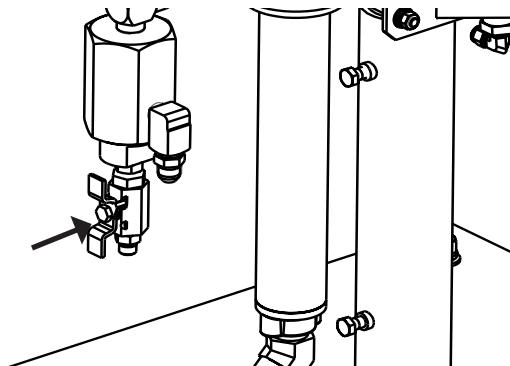

4. Verify the trigger lock is engaged.

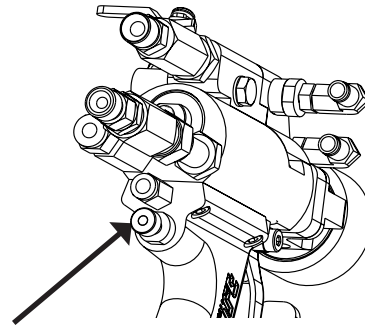

Daily Maintenance

It is recommended that the following service be performed on a daily basis.



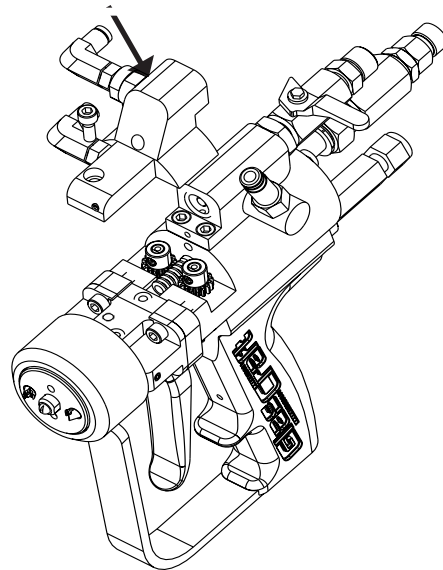

1. Remove gear cover, p/n: 23798-00, and inspect valves to see if there is any leakage, on the top or bottom side of the valves. If there is leakage, with pressure relieved, tighten packing nut, p/n: 23764-00 1/8 to 1/4 turn until leak stops. Verify that there is no leakage.



4. Maintain a reasonable stock level of "wear" items such as Packings, Seals and O-Rings
5. If dispense gun is leak tested, be sure to dry gun thoroughly.
6. **Never** leave dispense gun immersed in any liquid.

Maintenance

Parts Replacement Procedure Formula X Chop Gun

						
Before performing maintenance on the dispense gun, follow Pressure Relief Procedure.						

Notice

Due to the different o-ring materials and lubricants used in the dispense guns, never submerge or soak any dispense gun in any type of solvent. Submerging or soaking any dispense gun will immediately void the gun warranty.

1. Read each procedure entirely before beginning and refer to the illustration views as needed.
2. Flush and clean all passages as they become accessible.
3. Clean all parts before assembly.
4. Replace all O-Rings, Valves and Seals with new parts from the appropriate kit.
5. Inspect all parts for wear or damage and replace as required with new GENUINE GlasCraft REPLACEMENT PARTS from your authorized GlasCraft Distributor.
6. Inspect all threads for wear or damage and replace as required.
7. Tighten all threaded parts securely, but not excessively, upon assembly.
8. O-rings can fail if subjected to any of the following conditions.
 - a. Swelling - coming in contact with solvent or oil from compressor.
 - b. Cut - sharp, unlubricated edge in gun head or handle.
 - c. Sticky - contaminated with oil, water, solvent, catalyst, resin or gel-coat.
 - d. Chaffing - dry sliding surfaces (needs lubrication).

9. Lightly lubricate all O-Rings with petroleum jelly.
10. Check all springs for resilience. They should return quickly to their original (new) length.
11. Clean the exterior of the Gun and Hoses with an appropriate, clean solvent and cloth or brush.

Hose Removal

1. Release pressure (See page 19).
2. Remove resin Hose with an 11/16" wrench. (Hold delivery tube with an 11/16" wrench.)
3. Remove catalyst Hose with a 9/16" wrench. (Hold delivery tube with a 9/16" wrench.)
4. Remove solvent hose with a 5/8" wrench. (Hold delivery tube with a 9/16" wrench)
5. Remove all tubing lines by pushing in on the fitting and pulling the tubing out.
6. Remove the chopper air hose with a 11/16" wrench. (Hold the air hose inlet fitting with a 9/16" wrench)



Tape a clean polyethylene bag over the end of each Hose to prevent spillage and to keep clean.

Gun Service

Dispense Gun Component Service and Assembly Procedures



If Seal, P/N 23763-00 and Packing Disks, P/N 23721-04 are removed from the Gun Body GlasCraft recommends that these parts always be replaced with NEW seals and packing disks.

Maintenance

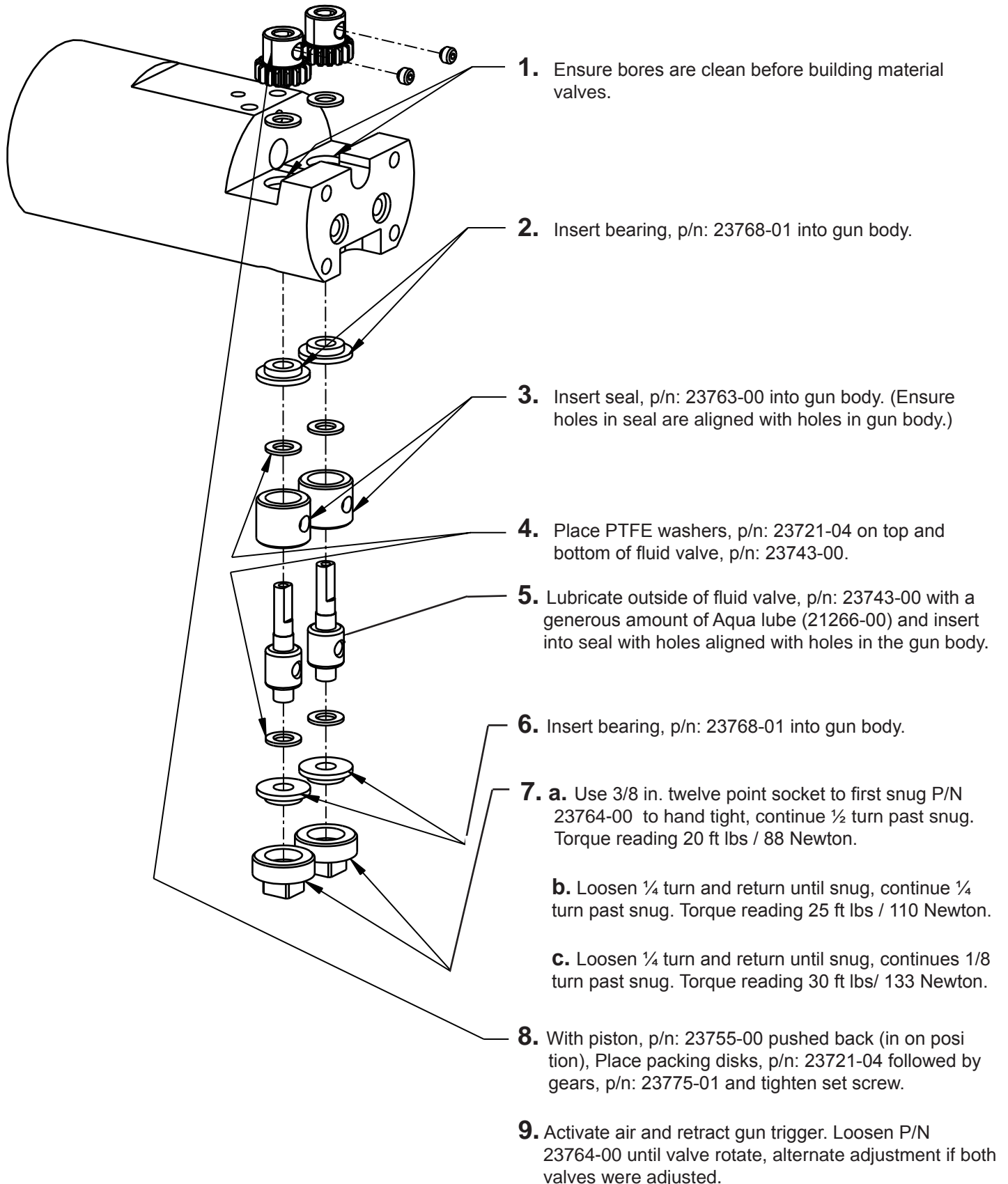

Accessories

Dispense Tip Reference Chart

Part Number	Orifice
23047-J1	.012
J2	.014
J3	.022
M1	.012
M2	.014
M3	.022
N1	.012
N2	.014
N3	.022
P1	.012
P2	.014
P3	.022

Note:

Use p/n: LPA2-120G and p/n: LPA2-121G
when using LPA2-147-XXXX and 23047-XX
series spray tips.

Accessories

Dispense Tip Reference Chart

LPA2-147-XXXX. (Requires Seal, P/N 20333-00 and Retainer, P/N 22274-00.)

Part Number	Orifice
LPA2-147-1525	0.015
1540	0.015
1550	0.015
1565	0.015
1825	0.018
1840	0.018
1850	0.018
1865	0.018
2125	0.021
2140	0.021
2150	0.021
2165	0.021
2325	0.023
2340	0.023
2350	0.023
2365	0.023
2625	0.026
2640	0.026
2650	0.026
2665	0.026
3125	0.031
3140	0.031
3150	0.031
3165	0.031
3625	0.036
3640	0.036
3650	0.036
3840	0.038
3850	0.038
4325	0.043
4340	0.043
4350	0.043
4365	0.043
5225	0.052
5240	0.052
5250	0.052
5265	0.052

Part Number	Orifice
LPA2-147-6225	0.062
6240	0.062
6250	0.062
6265	0.062
7240	0.072
7250	0.072
7840	0.078

Note:

Use p/n: LPA2-120G and p/n: LPA2-121G when using LPA2-147-XXXX and 23047-XX series spray tips.

Part Number	Orifice	
23005- TC6	0.060	*
TC7	0.070	*
TC8	0.080	*
TE7	0.070	*
TG7	0.070	*

*Indicates that these tips are made with A2 tool steel.

Accessories

Impingement Dispense Tip Reference Chart

Part Number	Orifice	Min. Width (in.)	Max. Width (in.)	Min. Output (lbs.)	Max Output (lbs.)	
23005-	C4	0.040	7	16.5	5.4	10.02
	C5	0.050	8.5	15.5	6.36	12.23
	C6	0.060	7	17	7.31	11.01
	C7	0.070	7	13	8.53	10.58
	C8	0.080	10	12.5	10.28	13.03
	C9	0.090	7.5	10	11.49	12.36
	E4	0.040	6	21	4.01	9.16
	E5	0.050	11	21	5.71	10.23
	E6	0.060	6.5	18.5	5.48	11.48
	E7	0.070	7.5	15	7.96	10.58
	E8	0.080	6	15.5	8.61	12.03
	E9	0.090	7.5	15	9.61	12.36
	G4	0.040	6	24	4.01	9.16
	G5	0.050	10.5	32	4.31	10.23
	G6	0.060	8.5	24	5.48	11.48
	G7	0.070	6.5	25.5	6.43	10.58
	G8	0.080	10	22	8.61	12.03
	G9	0.090	7	16	8.53	12.36
	J4	0.040	7	36.5	4.01	9.16
	J5	0.050	7	30.5	4.31	10.23
	J6	0.060	10	28	5.48	11.48
	J7	0.070	7.5	26	6.43	10.58
	J8	0.080	10	24	8.61	12.03
	J9	0.090	11	20	8.53	10.58
	K3	0.040				
	K4	0.040	9.5	38	4.01	9.16
	K5	0.050	12	34	4.31	10.23
	K6	0.060	16	34	5.48	11.48
	K7	0.070	13	30	6.43	10.58
	K8	0.080	8	28	6.21	12.03
	K9	0.090	11	25	7.88	12.36
	M4	0.040	11	61	4.01	9.16
	M5	0.050	13	38	4.31	10.23
	M6	0.060	9	38	4.33	11.48
	P4	0.040				

Technical Data

Category	Data
Maximum Fluid Working Pressure	2000 psi (14 MPa, 138 bar)
Maximum Air Inlet Pressure	100 psi (0.7 MPa, 7 bar)
Typical Flow Rate of Pattern Guns	Dependent of spray tip
Maximum Fluid temperature	100° F (38° C)
Trigger Air	1/4in. Tube
AAC Air	1/4in. Tube
Atomize Air	1/4in. Tube
Air inlet size (Chopper)	1/4-18 NPS Male
A Component (Catalyst) Inlet Size	1/4 in. Tube
B Component (Resin) Inlet Size	1/4-18 NPS Male
Sound Pressure	40.39 dB(A)
Sound Power, measured per ISO 94 16-2	56.2 dB(A)
Dimensions	10.54 L X 3.48 W X 8.25 H (267.84 X 88.49 X 209.75 mm)
Weight	2.14 Lbs.
Wetted Parts	Catalyst- Chemically coated aluminum, stainless steel, chemically resistant o-rings Resin- Carbon steel, carbide, chemically resistant o-rings.

Graco Ohio Standard Warranty

Graco warrants all equipment referenced in this document which is manufactured by Graco and bearing its name to be free from defects in material and workmanship on the date of sale to the original purchaser for use. With the exception of any special, extended, or limited warranty published by Graco, Graco will, for a period of twelve months from the date of sale, repair or replace any part of the equipment determined by Graco to be defective. This warranty applies only when the equipment is installed, operated and maintained in accordance with Graco's written recommendations.

This warranty does not cover, and Graco shall not be liable for general wear and tear, or any malfunction, damage or wear caused by faulty installation, misapplication, abrasion, corrosion, inadequate or improper maintenance, negligence, accident, tampering, or substitution of non-Graco component parts. Nor shall Graco be liable for malfunction, damage or wear caused by the incompatibility of Graco equipment with structures, accessories, equipment or materials not supplied by Graco, or the improper design, manufacture, installation, operation or maintenance of structures, accessories, equipment or materials not supplied by Graco.

This warranty is conditioned upon the prepaid return of the equipment claimed to be defective to an authorized Graco distributor for verification of the claimed defect. If the claimed defect is verified, Graco will repair or replace free of charge any defective parts. The equipment will be returned to the original purchaser transportation prepaid. If inspection of the equipment does not disclose any defect in material or workmanship, repairs will be made at a reasonable charge, which charges may include the costs of parts, labor, and transportation.

THIS WARRANTY IS EXCLUSIVE, AND IS IN LIEU OF ANY OTHER WARRANTIES, EXPRESS OR IMPLIED, INCLUDING BUT NOT LIMITED TO WARRANTY OF MERCHANTABILITY OR WARRANTY OF FITNESS FOR A PARTICULAR PURPOSE.

Graco's sole obligation and buyer's sole remedy for any breach of warranty shall be as set forth above. The buyer agrees that no other remedy (including, but not limited to, incidental or consequential damages for lost profits, lost sales, injury to person or property, or any other incidental or consequential loss) shall be available. Any action for breach of warranty must be brought within two (2) years of the date of sale.

GRACO MAKES NO WARRANTY, AND DISCLAIMS ALL IMPLIED WARRANTIES OF MERCHANTABILITY AND FITNESS FOR A PARTICULAR PURPOSE, IN CONNECTION WITH ACCESSORIES, EQUIPMENT, MATERIALS OR COMPONENTS SOLD BUT NOT MANUFACTURED BY GRACO. These items sold, but not manufactured by Graco (such as electric motors, switches, hose, etc.), are subject to the warranty, if any, of their manufacturer. Graco will provide purchaser with reasonable assistance in making any claim for breach of these warranties.

In no event will Graco be liable for indirect, incidental, special or consequential damages resulting from Graco supplying equipment hereunder, or the furnishing, performance, or use of any products or other goods sold hereto, whether due to a breach of contract, breach of warranty, the negligence of Graco, or otherwise.

FOR GRACO CANADA CUSTOMERS

The Parties acknowledge that they have required that the present document, as well as all documents, notices and legal proceedings entered into, given or instituted pursuant hereto or relating directly or indirectly hereto, be drawn up in English. Les parties reconnaissent avoir convenu que la rédaction du présente document sera en Anglais, ainsi que tous documents, avis et procédures judiciaires exécutés, donnés ou intentés, à la suite de ou en rapport, directement ou indirectement, avec les procédures concernées.

Graco Ohio Information

TO PLACE AN ORDER, contact your Graco distributor or call to identify the nearest distributor.

Toll Free: 1-800-746-1334 **or Fax:** 330-966-3006

For the latest information about Graco products, visit www.graco.com.

*All written and visual data contained in this document reflects the latest product information available at the time of publication.
Graco reserves the right to make changes at any time without notice.*

Original instructions. This manual contains English. MM GC-1402

Graco Headquarters: Minneapolis

International Offices: Belgium, China, Japan, Korea

GRACO OHIO INC. 8400 PORT JACKSON AVE NW, NORTH CANTON, OH 44720

Copyright 2008, Graco Ohio Inc. is registered to ISO 9001

www.graco.com

Revised 04/2010