



Installation & User Manual

Wireless Power and Communication Kit for Hi-Lo Relief System

This manual provides installation instructions for Cascade Wireless Power and Communications Kit for Hi-Lo Relief System. This kits allows 12W of inductive power transfer when the ST and SR units are in alignment. At all times a 2.4 Ghz RF signal provides two digital switch input and outputs (5A total) each direction as well as providing a generic CAN bus node. The RF features have a 10 M range and meet EMC (EN 12895) and FCC standards.

NOTE: Kits are UL Classified (File # AU3546) for safety in Electric Battery (UL 583) and IC Engine (UL 558) Indust. Truck type E, ES, G, GS,G/LP/ GS/LPS, LP, LPS, D and DS.

NOTE: UL Classified Kits require installation by qualified personnel only without major disturbance, cutting, splicing or soldering of factory installed wiring.

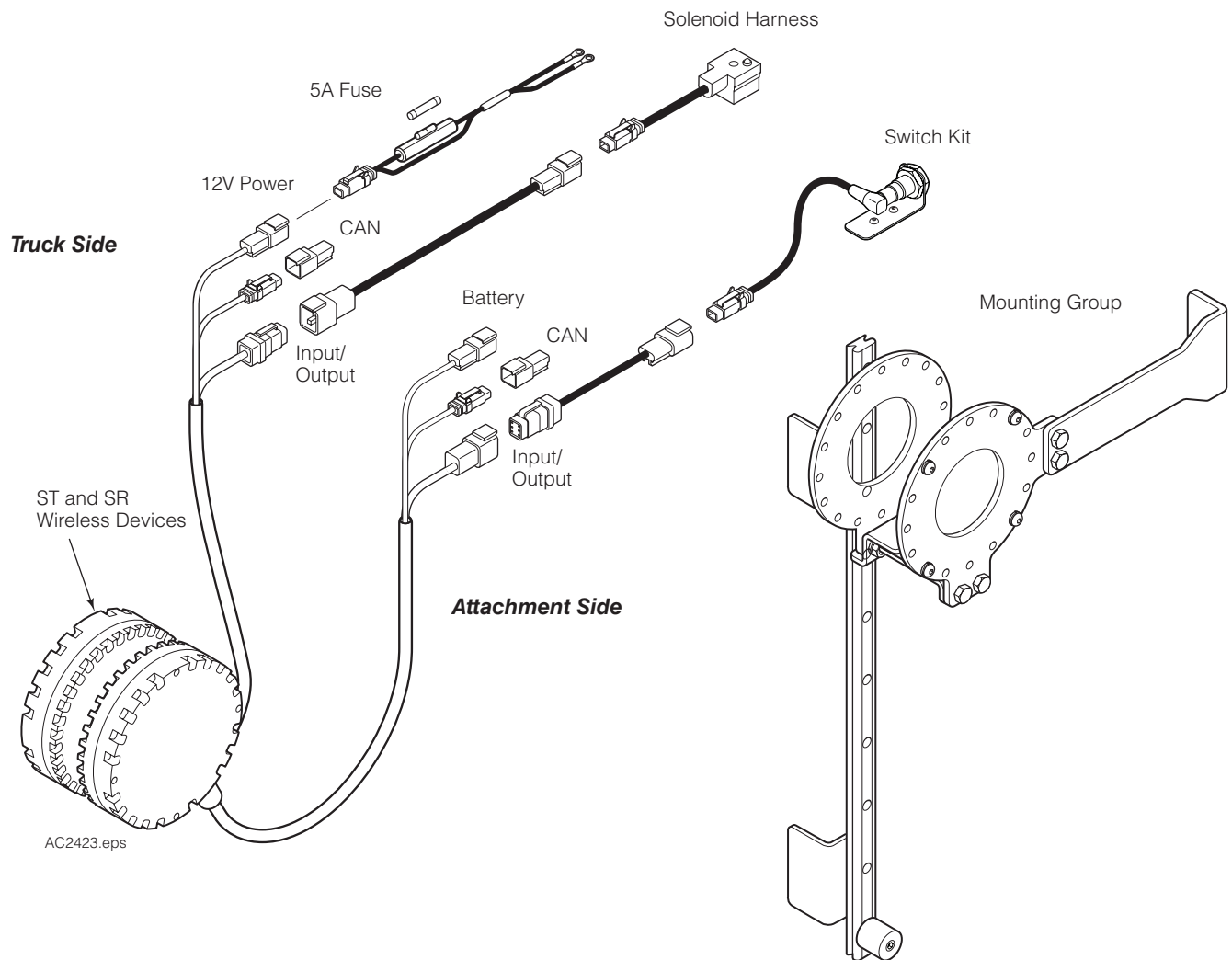

cascade®
corporation

For Technical Support . . .

Call: 1-800-227-2233 Fax: 1-888-329-8207
Internet: www.cascorp.com
Write: Cascade Corporation, PO Box 20187, Portland, OR 97294

To Order Parts . . .

Call: 1-888-227-2233 Fax: 1-888-329-0234
Internet: www.cascorp.com
Write: Cascade Corporation, 2501 Sheridan Ave., Springfield, OH 45505

Uses



Cascade Corp.
File No. AU3546

Electrical
Components

Kit Installation

Perform by Qualified Personnel only.

- 1 Mount the ST and SR units so that the faces are parallel and .25-1.00 in. (6-25 mm) apart. Orient the cables as required.

If mounting hardware is included, modifications may be required for your installation.

Mount the SR slider mechanism fixed to the carriage. Use the load backrest holes if possible. Make sure the top of the slider is not above the carriage or attachment and the bottom is hidden behind the frame or high enough to avoid hitting the ground.

Mount the ST unit bracket to the mast so that when the carriage is in its lowest position, the SR unit is supported near the top of the slider rail.

Check for clearance through the full range of slide movement while tilting forward and fully back.

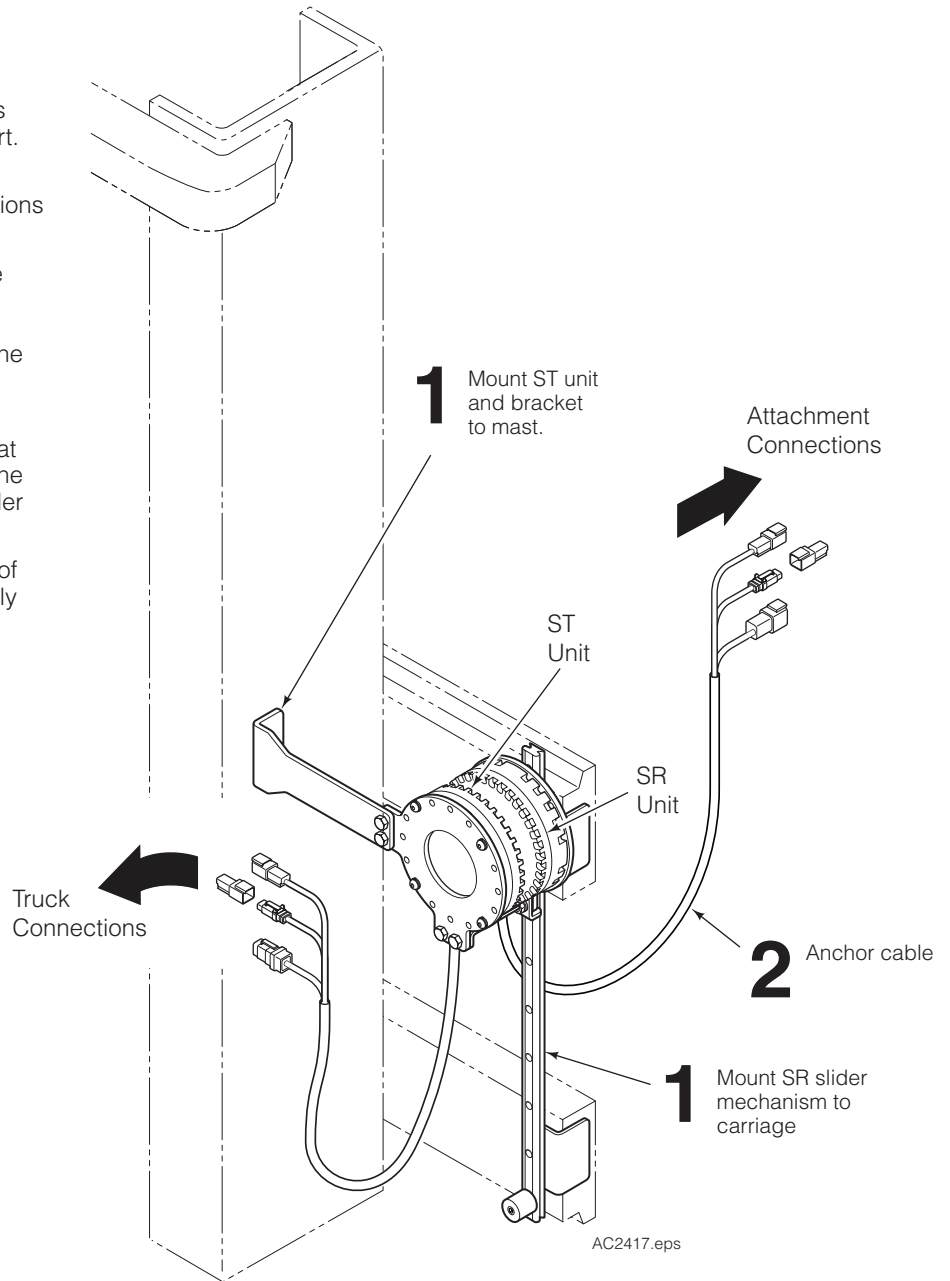
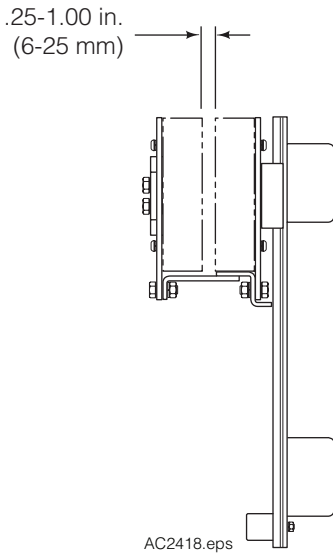

- 2 Route the SR unit cable so movement of the SR along the guide does not bind or snag. Anchor the cable as required.

- 3 Disconnect the negative battery terminal as directed by the truck OEM.

NOTE: UL Classified kits require installation by qualified personnel only, without major disturbance of cutting, splicing or soldering of factory installed wiring.

CAUTION: Consult the Lift Truck OEM for proper + power source connection.

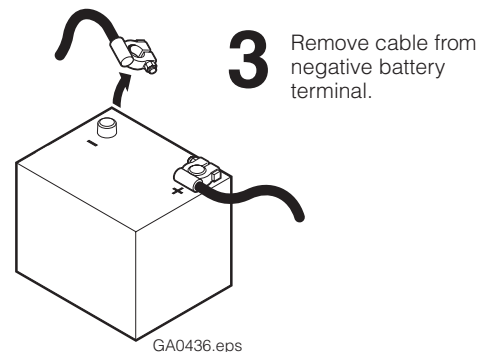

4 Connect cable ends to the components as shown.

12V Systems – Connect the fused positive wire from the cable harness to a 12V switched power source, and the negative wire to a ground.

Check the cable routing for pinch points and clearance. Use wire ties as needed.



WARNING: To reduce risk of fire, replace only with the same type and ratings of fuse. The fused power cable is polarity sensitive. The positive wire must be connected to a positive power source.

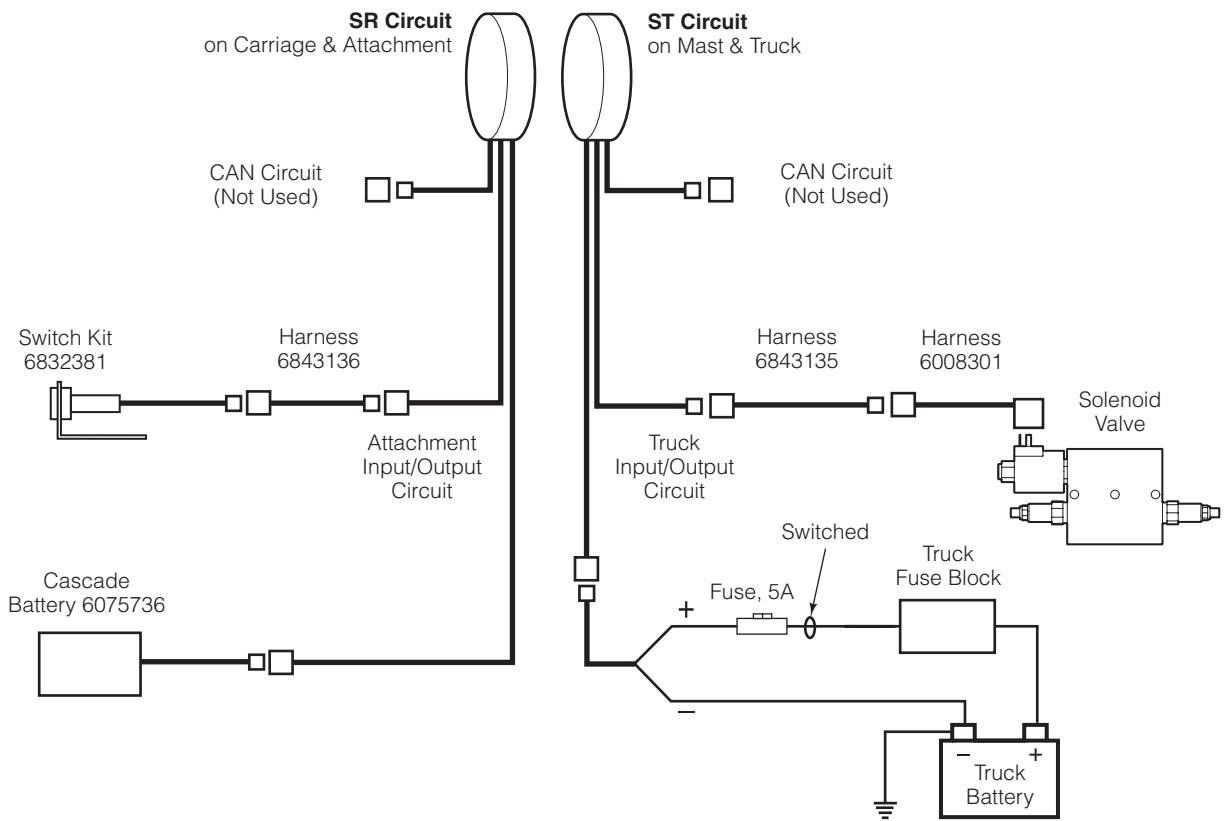

AC2424.eps

Test Procedure

Perform by Qualified Personnel only.

At the SR unit, connect only Cascade Battery 6075736 to the connector marked 'BATTERY'. With power ON at the ST unit:

- Align units and verify inductive power yields 14V minimum at SR 6 pin LOAD line connector. Pin 1(+) and Pin 6(-).
- Move units out of alignment and verify LOAD line voltage drops to the battery voltage.
- Turn off power to ST unit, wait 5 minutes (do not vibrate or bump the SR unit) and verify that the LOAD line voltage drops to near 0V.

Wireless Power and Communication Kit

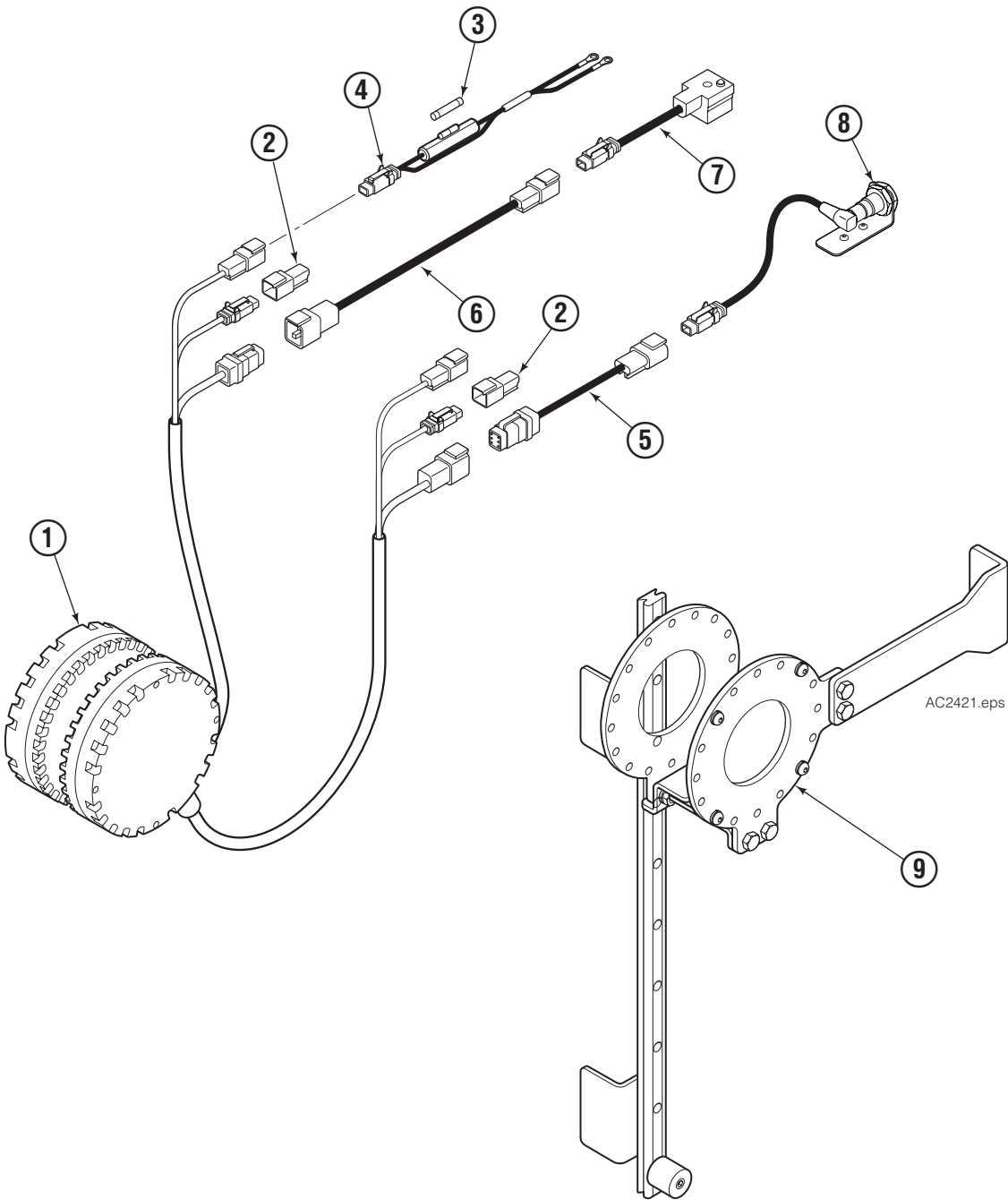

REF	QTY	PART NO.	DESCRIPTION
		6842546	Wireless Power/Comm Kit – 12V
1	1	6829906	Wireless Power/Comm Device
2	1	6842851	Seal Plug
3	1	6806708	Fuse, 5 Amp
4	1	6048139	Cable Harness

REF	QTY	PART NO.	DESCRIPTION
		6843167	Harness Kit
5	1	6843136	Harness-ST I/O
6	1	6843135	Harness-SR I/O
7	1	6008301	Harness-Solenoid

8	1	6832381	Switch Kit ●
9	1	6843082	Mounting Kit ●

● See following parts page for breakdown.

Switch Kit

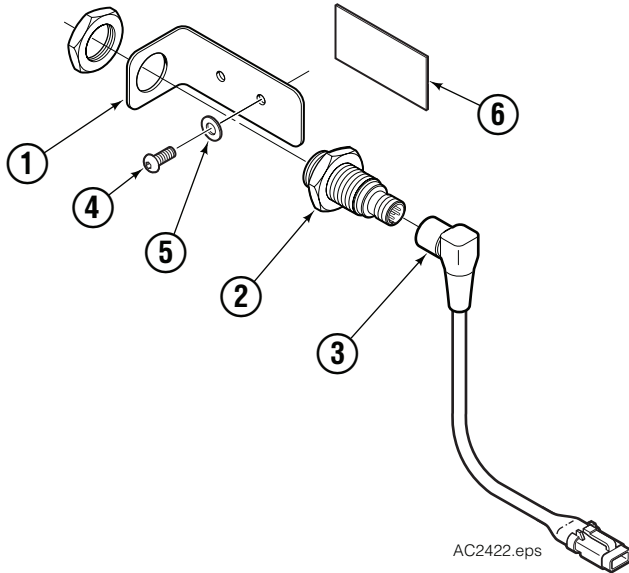

REF	QTY	PART NO.	DESCRIPTION
		6832381	Switch Kit
1	1	6091430	Angle Bracket
2	1	6092966	Proximity Switch
3	1	6832382	Cable Assembly
4	2	6076098	Cap screw, M4 x 6
5	2	686454	Washer, M4
6	2	6014987	Adhesive Tape

Mounting Group

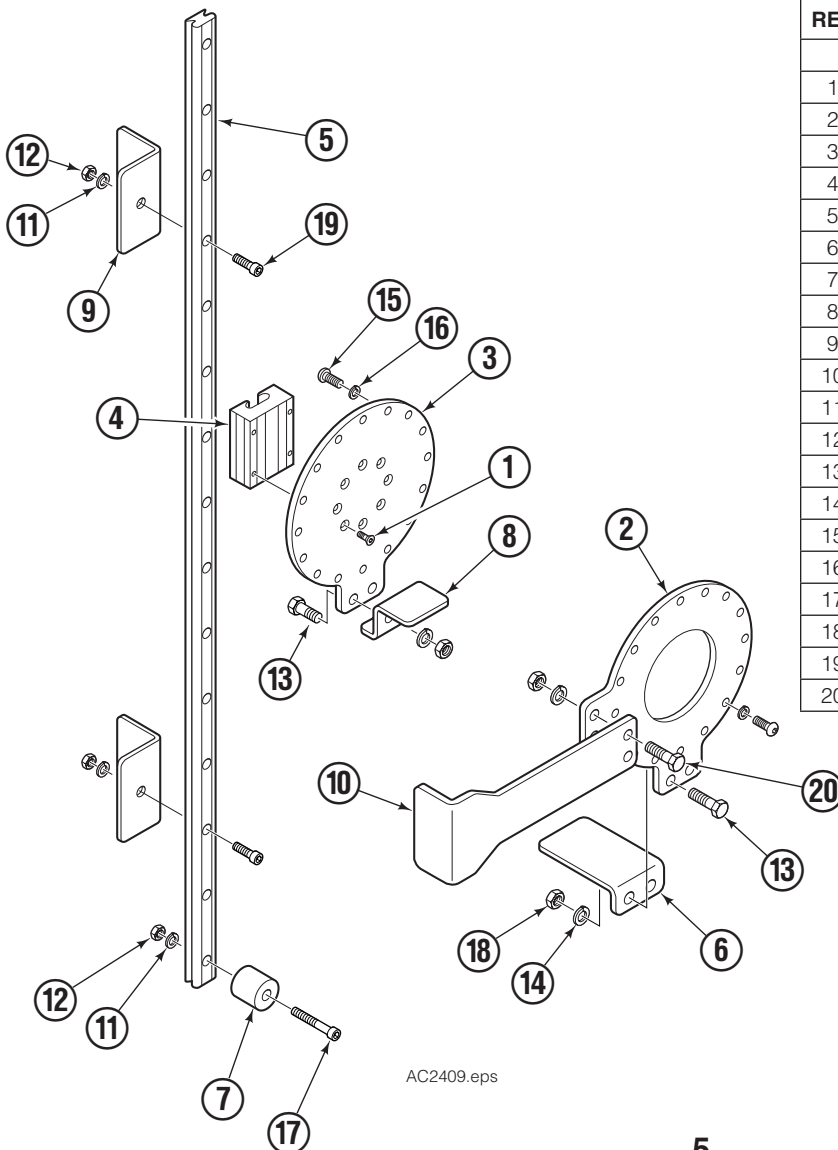

REF	QTY	PART NO.	DESCRIPTION
		6843082	Mounting Group
1	4	6405844	Cap screw, M4 x 12
2	1	6829954	Mounting Plate
3	1	6830008	Mounting Plate
4	1	6839466	Carriage
5	1	6839469	Rail
6	1	6839966	Bracket
7	1	6840040	Stop
8	1	6840048	Bracket
9	2	6840630	Bracket
10	1	6840657	Bracket
11	3	685901	Lockwasher, M5
12	3	768202	Nut, M5
13	4	787372	Cap screw, M8 x 20
14	6	206315	Lockwasher, M8
15	8	220436	Cap screw, M6 x 16
16	8	678993	Lockwasher, M6
17	1	685862	Cap screw, M5 x 40
18	6	767414	Nut, M8
19	2	768220	Cap screw, M5 x 20
20	2	787373	Cap screw, M8 x 25

Battery Assembly

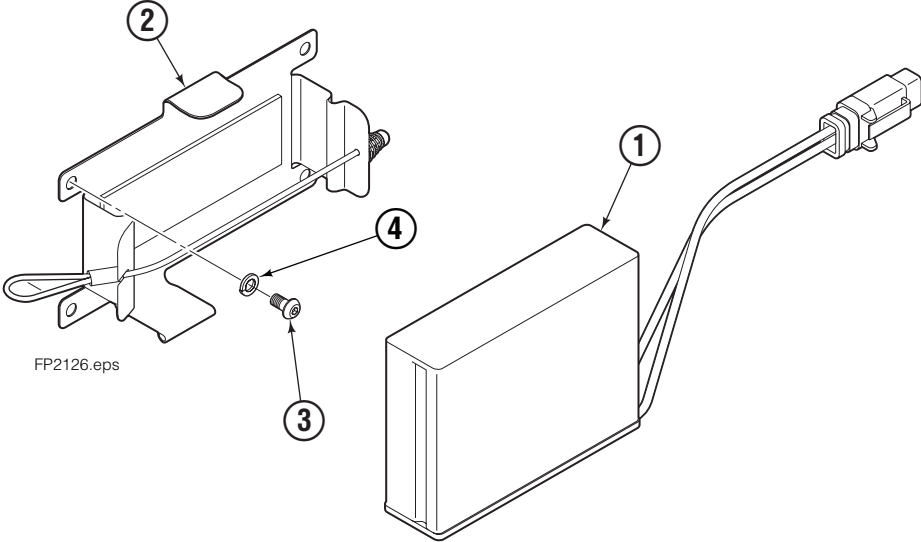

REF	QTY	PART NO.	DESCRIPTION
		6843202	Battery Assembly
1	1	6075736	Battery
2	1	6094986	Retainer Clip Assembly
3	4	6071505	Capscrew
4	4	685899	Lockwasher

Specifications

Description and Operation: A three function device providing
 1) Inductive battery charger for Cascade Li-Ion battery's, 2) RF CAN bus node with 10m range and 3) RF digital switching device with two remote inputs and two remote outputs with 60W (limited by OCP) of switching power provided by the Cascade Battery as well as a 16W* load line for remote sensor/controller power.

Two main components include:

ST = Transmitter, typically located on the host device and the SR = Receiver, typically located remotely and requires a Cascade Battery for 'out of range' power.

* Actual power available depends on battery condition.

Electrical	
ST Input Voltage	9V to 16V DC (12V DC Nominal)
ST Start Up current requirement	5A
ST Typical operating current	<3A Note: Input is fused at 5A per UL requirements.
ST Max power required (at 14.4v)	72W
Inductive Power Transfer (in Range **)	12W - nom. 12VDC/1A
SR Input Voltage:	Cascade Battery Voltage only (12.5V)
SR load Line & GPO voltage (in Range**)	14.4V +/- 5%
SR load Line & GPO voltage (out of Range**)	Cascade Battery Voltage (12.5V to 10.0V min)
SR Load Line Over Current Protection (OCP)	1.6A (shutdown with auto reset)
GPO Over Current Protection (OCP)	5A typical total, +2.5A / -1.2A (shutdown with auto reset) Recommended Limits: -3A on any one channel alone (tested to 17% duty cycle) -1.5A / channel simultaneous (recommended) (tested to 80% duty cycle)

Protection	
ESD	8kV any contact and 15kV air to case
Reverse Input Voltage at ST only	14.4 Volts (ST) Unprotected (SR)
High Voltage protected (ST)	SAE J1455 Double Jump 28.7V Surge Limit 41V Use appropriate dc/dc converter and filters
Short Circuit protection at GPO's (ST and SR)	Protected: Auto Reset

Performance		
RF		
	RF Range	10m (in typical truck application, Not LOS)
	Data rate	1Mbps
	Operating Freq	2.4-2.4835GHz
	RF CANbus node (bi-directional)	Protocol independent, J1939,CANopen and DeviceNet supported
	CAN message Response Time	66ms (avg), 106ms (max)
	CAN PNG Address Limits (factory set)	FFC0 to FFC1 inclusive FF00 to FF34 inclusive Note: - PNG address will be allowed in either direction: - FF01 message is sent every 1 second.

Performance		
SR Power required (RF Data Only)		75mA nom (.85W)
2x2 GPIO		2 x Input and 2 x Output at each transceiver
	Inputs	PNP Sensors suitable Input voltage 9 to 24 VDC
	Outputs	Local (+) voltage, 3A per channel or 5A total ST = input voltage SR = (see Load Line & GPO voltage above)
	GPIO Response Time	45ms (avg), 80ms (max)
	GPO Latching	None GPO's un-latch after 1.5s (Voltage goes 'Low' after 1.5s when power goes off).

***Battery Information	
Use only Cascade Li-Ion Battery pn 6075736	3 cell 11.1V 2200 mAH
Battery Rating	12.54V - 9.8V, 2200 mAH, 6.5A current load limited Shuts down when voltage is less than 9.8V
Battery Life (out or Range*)	27 hrs RF full time, No GPO load, SR 'ON' 120 hrs uninterrupted sleep mode, SR 'OFF'

Inductive Power at optimal range*	
Cascade Li-Ion Batt charging circuit	Fully charge in 2.5 hrs at optimal alignment.
Seamless Transition between Battery/Inductive Power	Battery Voltage / 14.4V

Specifications

SR Power Management	
Inductive Power at optimal Alignment (range*)	12W Unused Power is charging the Battery. Demand over 12W, draws additional power from Battery Up to 72W nom. /2200mAhrs at full charge.
Not Aligned for Inductive Power	Up to 72W nom. /2200mAhrs at full charge on Load Line and GPO from Battery only.
SR Power required (RF Data Only)	75mA Nom. (.85W)

Environmental	
Vibration	10-12g RMS
Drop Test	3 ft bench drop (in packaging)
Operating Temp	-40 to 60C (140F)
Storage Temp	-55 to 85C (185F)
Sealing to environment	IP 66
Humidity	to 90% (no condensation)

Physical Dimensions and Mounting	
Diameter	145mm
Thickness	37mm
Weight (pair)	2.0kg
Mounting holes	M6 x 4 x 12 deep, equally spaced
Mounting Hole Bolt Circle	137mm dia (equally spaced)
Cable Gland	22mm tall (approx.)
Cable Length	1.5M=SR, 1.0M=ST

Microchip Wi-Fi Module Information	
Microchip MRF24W80MA Wi-Fi Module Data	
2.4 GHz	802.11 Low Power Transceiver
Wi-Fi Certified for 802.11b	
RoHS compliant	
CE Compliant	
FCC Certified (US FCC ID: W7O-ZG2100-ZG2101)	
IC Certified (IC:8248A-G21ZEROG)	
Fully Compliant with EU and meets R&ETT Directive for Radio Spectrum	
Radio Type Approval Certified in Europe (ETST) and Japan ARIB).	
WFA ID: WFA7150	

*Range: Distance and alignment for optimal inductive power transfer	
Power Trans Distance	6mm to 25mm (Over 25mm, power transfer eff. deteriorates)
Mis Alignment allowance (center line axis)	12mm (Over 12mm, power transfer eff. deteriorates)
Angular Alignment allowance (non parallel face angle)	+/- 15 deg. Misalignment causes power transfer eff. to deteriorate.
Radial Orientation Limits for mounting (around center line)	None
Sleep Mode time out at SR after ST powered 'off'	5 minutes
Sleep mode power demand	18mA Nom.
Sleep Mode 'wake up'	Aligned: Power up ST. Not Aligned: Vibration is required. ST power 'ON' to communicate.
'Wake Up' Accelerometer Sensitivity	Field Adjustable, contact Cascade Corp
Wake Up response time	2 sec (max)

Wire Color and Function Code			
Wire No.	Color	STx	SRx
1	Red	Fork Lift Battery Positive	Cascade Battery Positive
2	Black	Fork Lift Battery Negative	Cascade Battery Negative
3	Yellow	CAN Hi	CAN Hi
4	Green	CAN Lo	CAN Lo
5	Grey	No Connection	Load Positive
6	White	No Connection	Load GND
7	Orange	GPI No.1	GPI No.1
8	Violet	GPI No.2	GPI No.2
9	Blue	GPO No.1	GPO No.1
10	Brown	GPO No.2	GPO No.2

Certifications	
CE Mark	YES - DoC maintained by OEM (PbP). EN12895, FCC Part 18, RoHS
UL Classified	File # AU3546 (UL 558/583)

