

ANCHORLIFT[®]

WORLD CLASS WINDLASS SYSTEM

CE

User and Installation Manual^{US}

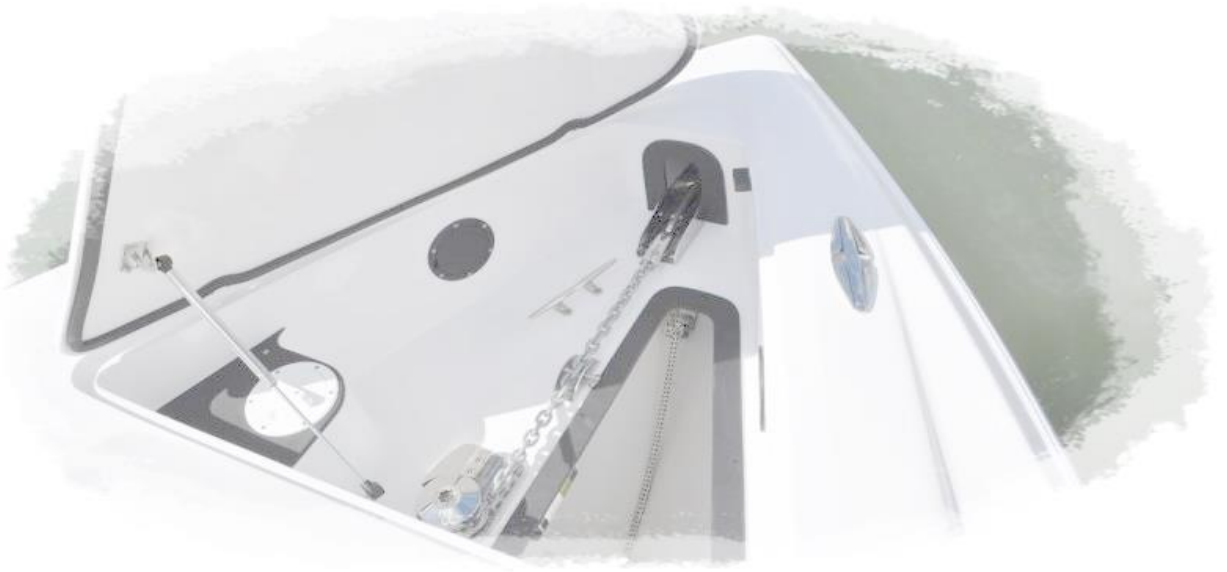

Thank you for choosing **ANCHORLIFT** windlass system on your boat.

Please take the time to read the instruction in this user and installation guide carefully.

This will help you set up and operate your windlass system so you can have a trouble free operation in years to come.

More installation information can be found on our web pages www.anchorlift.com

Please ensure that you thoroughly understand the operation and safety requirements of the windlass before you begin installing.

READ THIS USER MANUAL THOROUGHLY BEFORE INSTALLATION OF YOUR WINDLASS

WARNING !

Windlasses are designed to cast and lift anchors, DO NOT use the equipment for other purposes.

WARNING !

Always fasten the chain or rope (preferably with a chain stopper) before moving to navigation.

WARNING !

Always use a circuit breaker to protect the windlass engine and electrical cables.

WARNING !

To avoid personal injury, keep well clear of the windlass while it is under motion.

WARNING !

Do not operate the windlass by using the electrical power when the clutch handle is inserted in the cover of the gypsy.

Make sure that the electrical power to the motor is shut off when working on the windlass.

Carefully remove the chain or rope from the gypsy or the rope from the drum.

WARNING!

Make sure that the windlass shaft, gear box hollow shaft are well greased with suitable marine grease before installing. See picture **P 1**

Protect the complete gear box and electric motor with suitable marine anti corrosion wax spray such as CRC Heavy Duty Corrosion Inhibitor, Tectyl or simmilar products, see picture **P 2**.

P 1. Grease Here !



P 2.



Improper installation will result in a void in warranty!

Anchorlift gear box is fitted with removeble mounting flange that can be mounted on both sides of the gear box. Its important that the motor are mounted as far away as possible from the chain pipe hole.

Ideal.

Ideal.

Ideal.

Ok.

Ok.



Before mounting.

The standard package consists of: Windlass deck unit - Gear motor unit - Solenoid - Clutch handle
Bolts & screws for fastening and user manual.

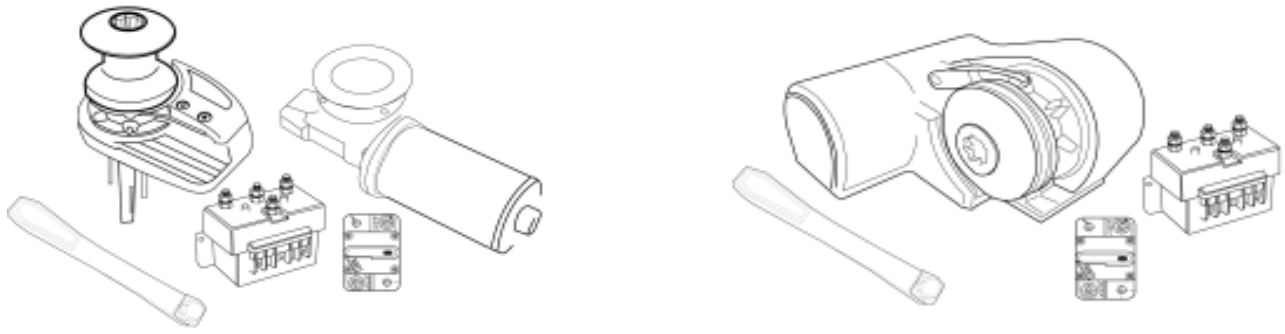

Recommended on all installations: Helm switch, Foot switches, Circuit breaker, Radio remote optional.



Assembly

The windlass is to be placed in position by aligning the gypsy with the bow point (rope or chain level with the deck and wound around the gypsy at an angle of about 180 degree)
Before drilling holes, check the following: There are to be no obstacles below deck in order to install the bottom part. There must be enough space for the chain - Rope / chain.
Also make sure the top and bottom surfaces of the deck are as parallel as possible, if necessary compensate for any differences to prevent base & gearbox (se picture P 5) from being damaged. Once the ideal position has been found, drill the holes using the mounting template. Place the top part (base) in position and connect it to the bottom part (geared motor). Fit the shaft into the gearbox. **MAKE SURE THE SHAFT IS WELL GREASED !!**
MAKE SURE THE SHAFT AND GIR BOX HOLLOW SHAFT IS WELL GREASED !!
before connected to the gearbox. See the wiring diagram for the electrical installation for your windlass size. After installing USE anti corrosion marine wax protection on the motor and gearbox. See picture P 2.

The vertical windlasses Barracuda, Dolphin & Mako are equipped with 4 8 mm stainless steel pin bolts. When installing the windlasses on deck use a 10 mm drill for the pin bolts.

Deck thickness:

Barracuda: 20 - 40mm / 3/4" - 1 1/2"

Dolphin & Mako: 25 - 50mm - 1 - 2"

Aquarius: Up to 150mm 6"

Stingray: With standard bolts Up to 60mm 2,5"

For deck thickness greater then the maximum measures mentioned here, please contact your nearest dealer for advice.

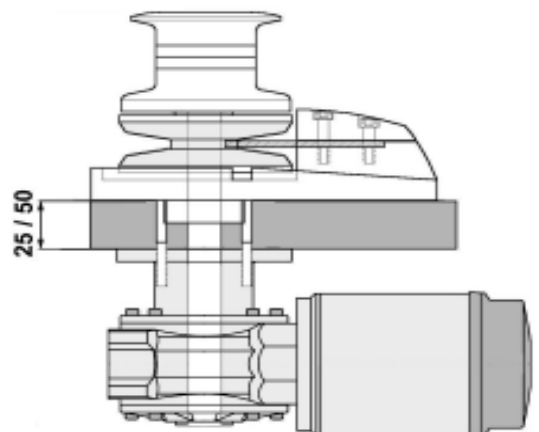

When installing make sure to position the windlass so that the centre line of the chain / rope aligns with the bow roller in a horizontal plane, and that the vertical line is within 10 degrees (P 4) of the rope / chain gypsy.

Before installing turn the windlasses over and supply a suitable bead of sealant as shown below..

P 3.

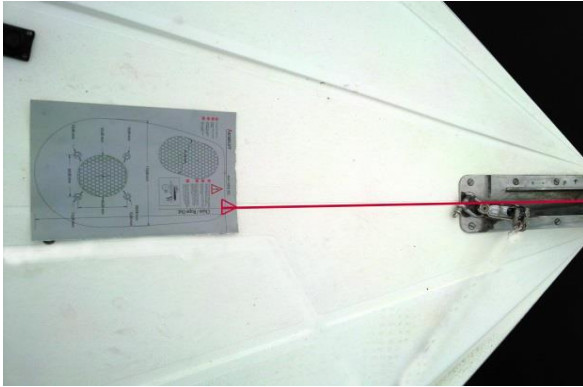

Drill and cut out holes to the size detailed on the template.

Ensure that the chainpipe hole is angled (P 3) and clean to allow rope to smoothly pass through it.

With a sandwich construction, it is important to seal the exposed surface (P 4)

P 4.

max/min 10degree

P 5.

P 6.

P 7.

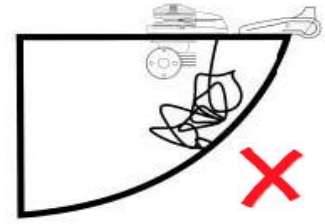
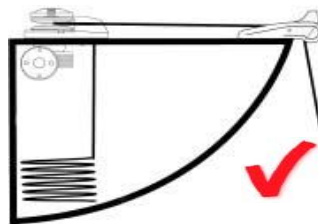
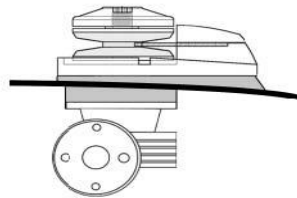
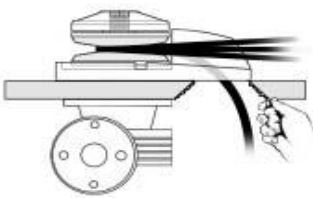

Care should be taken when installing the windlass to ensure that the vertical drop below the chain pipe exit is maximized. Remember that rope coils is unlike chain, and will require as much anchor locker space as possible, see picture P 6 and P 7.

Wiring data.

Cable sizes

Anchorlift recommend the use of the following cable, switch-wiring and circuit breaker sizes:

Note;

Cable and terminals should be suitable for 6 mm Barracuda / Dolphin and 8mm for Mako / Aquarius.

The Stingray has motor cables supplied as standard.

Windlass performance is directly related to cable size and length.

Voltage drop over the complete wiring run must not exceed 2 volts.

Use the Anchorlift original slow blow breaker on your windlass.

Windlass:	Cable length: 0-8m 0-24ft		over 8m 24ft		Circuit Breaker:
Barracuda 600 - 700	16mm ²	5 AWG	25mm ²	2 AWG	80 amp (90080)
Barracuda 900 - 1000	25mm ²	2 AWG	35mm ²	1 AWG	100 amp (90100)
Dolphin 1000	25mm ²	2 AWG	35mm ²	2 AWG	100 amp (90100)
Stingray 1000	16mm ²	5 AWG	25mm ²	2 AWG	80 amp (90080)
Mako 1200-1500 12v	35mm ²	2 AWG	50mm ²	0 AWG	135amp (90135)
Mako 1200-1500 24v	25mm ²	2 AWG	35mm ²	2 AWG	100amp (90100)
Aquarius 2500 24v	35mm ²	2 AWG	50mm ²	0 AWG	175 amp (90175)

Electrical connections 2 wire motor.

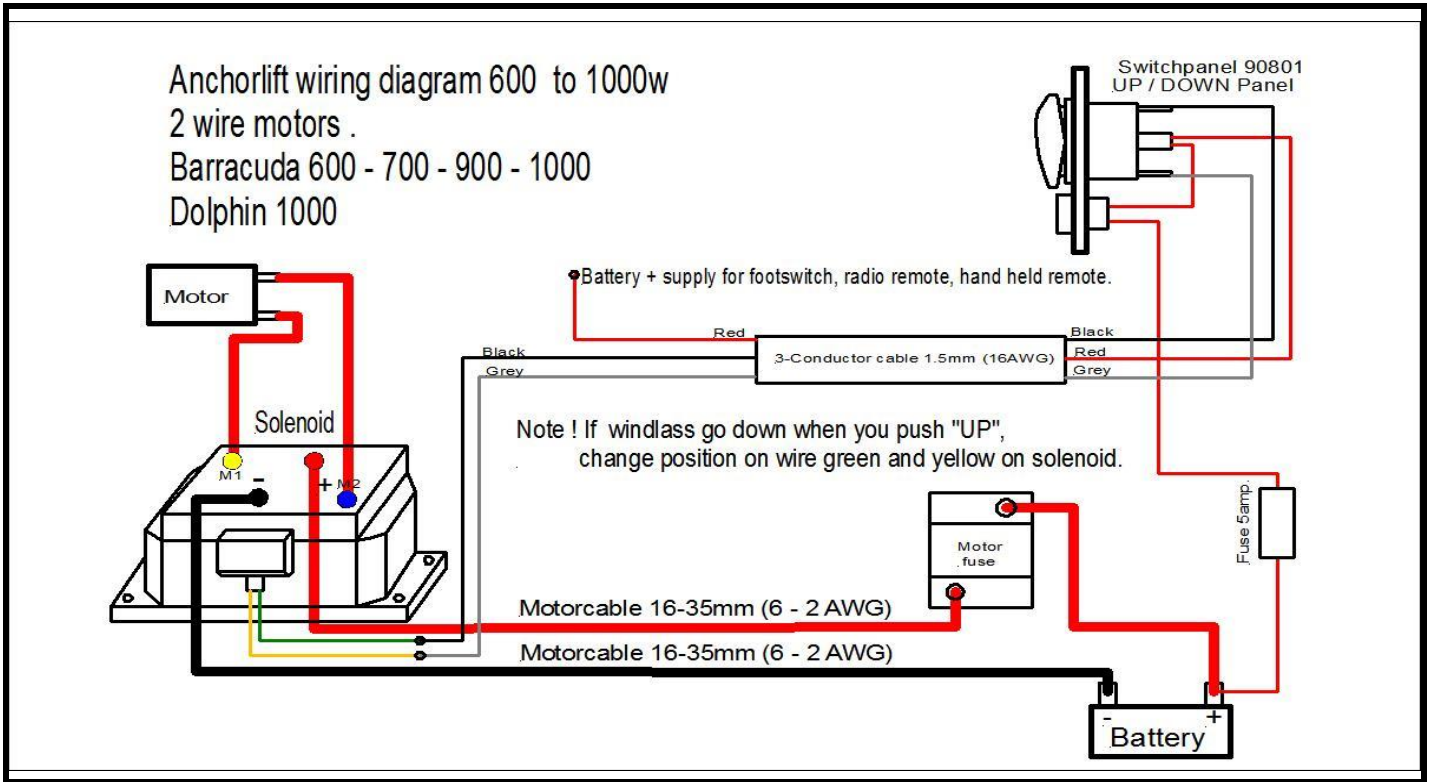

Electrical connections 3 wire motor.

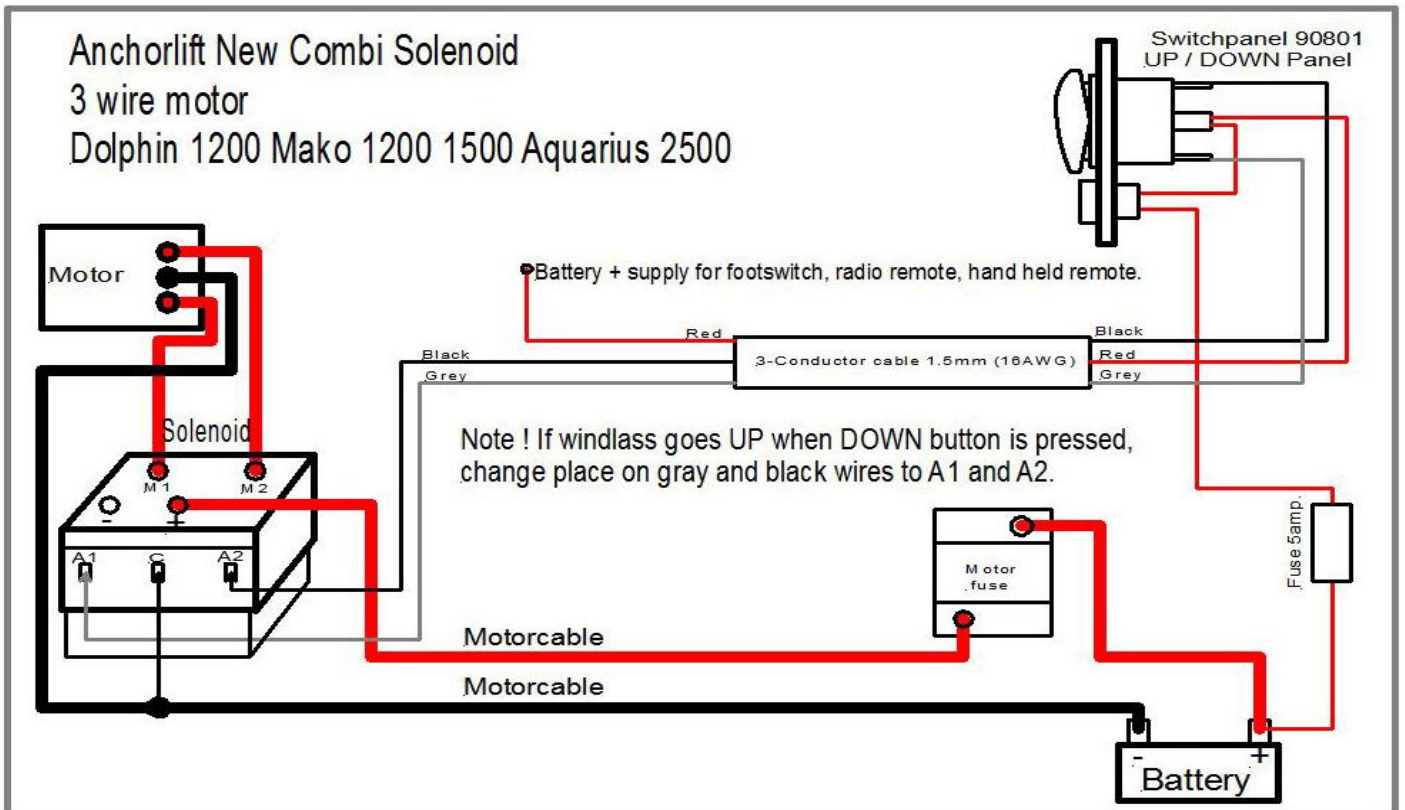

WARNING

MAKE SURE THE ELECTRICAL POWER IS SWITCHED OFF BEFORE WORKING WITH ELECTRIC CABLES.

Motor boat installation using the vertical low profile windlass model with 2 wire motor.

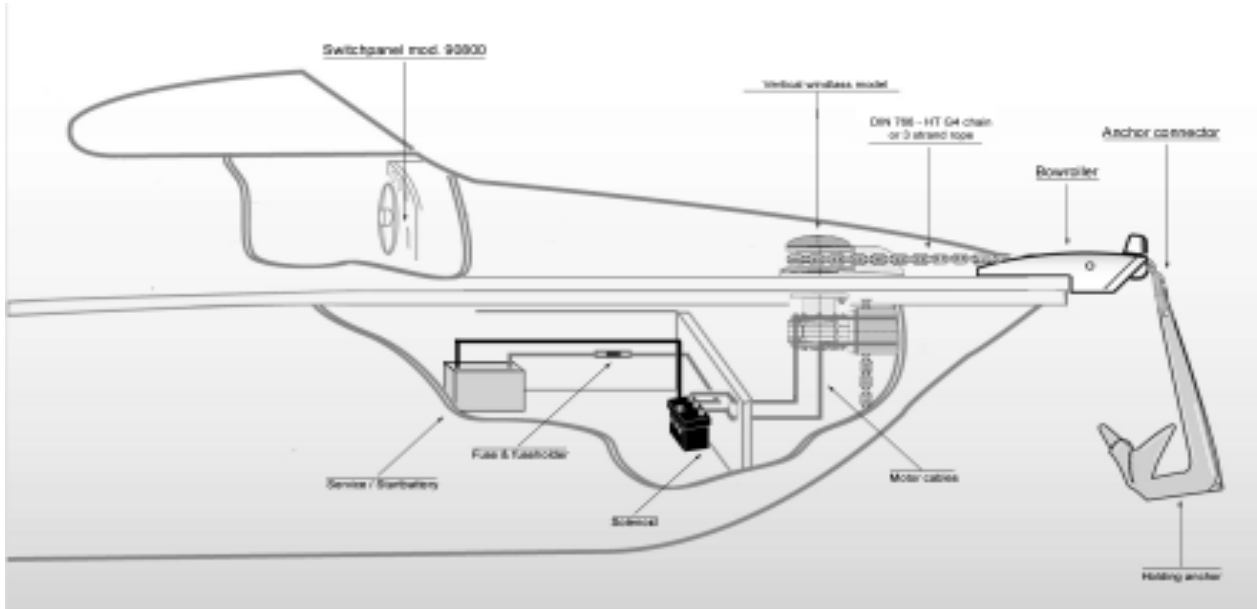

Sail boat installation using the vertical low profile windlass model with 3 wire motor.

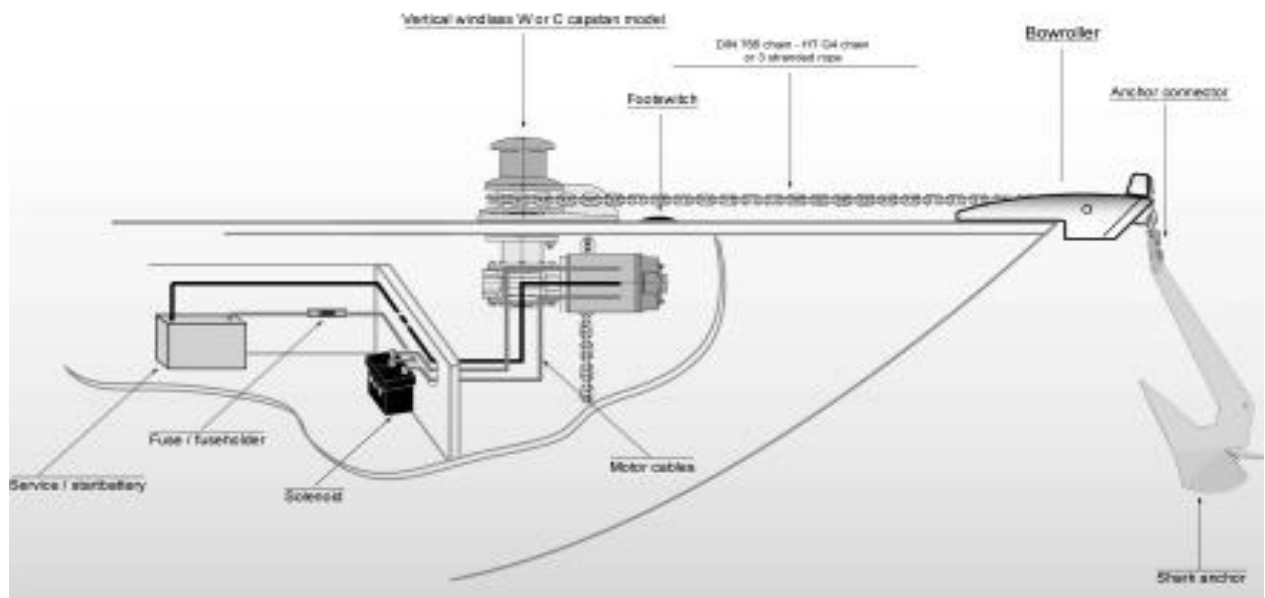

Motor boat installation using the Stingray horizontal model.

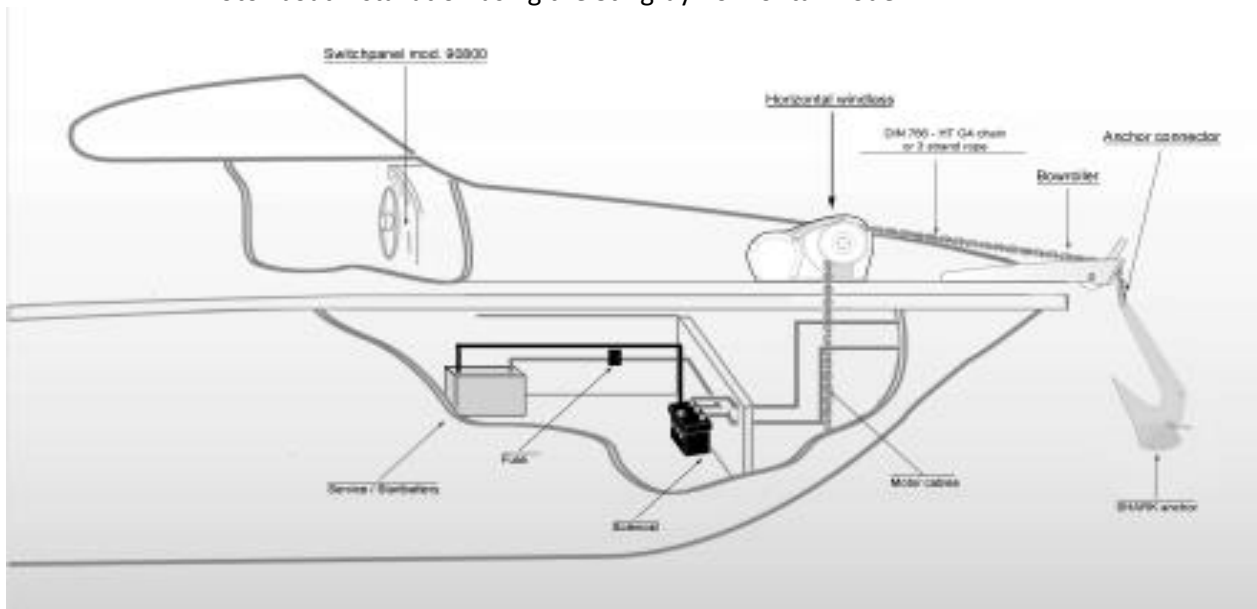

ITEM DESCRIPTION

- 1 Chain pipe cover
- 2 Pin - spring
- 3 Pressure finger
- 4 Spring
- 5 Base
- 6 Connection bolt
- 7 Rope fork
- 8 Lid cover bolt
- 9 Key
- 10 Gypsy shaft
- 11 Combo shaft
- 12 Clip - 1
- 13 Bearing
- 14 Clip - 2
- 15 Oil seal
- 16 Washer
- 17 Cone clutch
- 18 Gypsy
- 19 Gypsy cap
- 20 Capstan
- 21 Capstan screw
- 22 Clutch handle

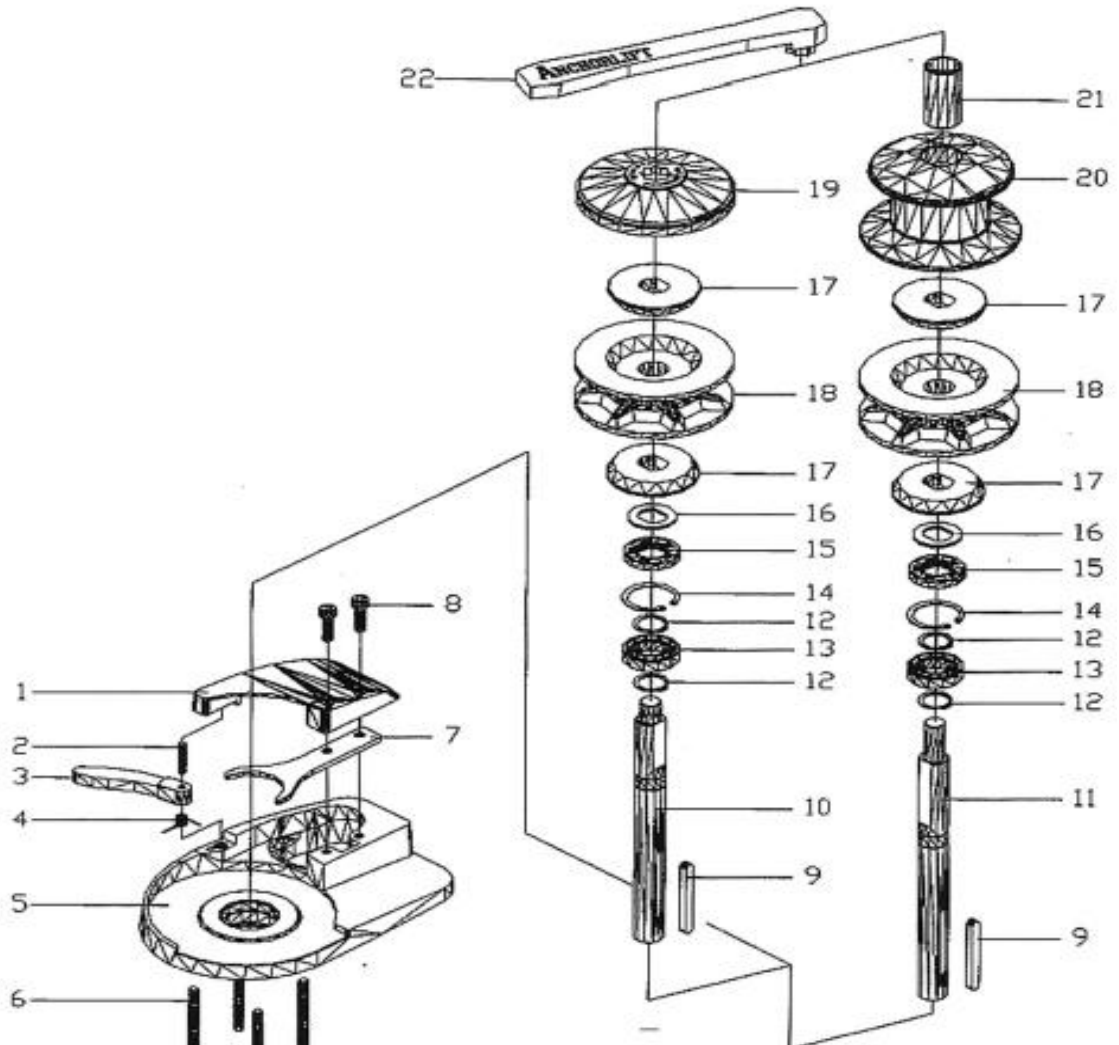

Anchorlift windlasses are constructed with materials resistant to marine environments. In case, any salt deposits on the outside must be removed periodically to avoid corrosion and damage to the equipment. The part where salt may have built up should be washed thoroughly with fresh water. Once a year – the drum and gypsy are to be taken a part as follows.

Drum version:

Use the handle (22) to loosen the capstan screw (21), pull off the drum / capstan (20) and the top clutch cone (17). Loosen the lid cover bolts (8) on the chain pipe cover (1) and remove both parts. Pull away the pressure finger (3) from the gypsy (18) and remove the gypsy.

Low profile version:

Use the handle (22) to remove the gypsy cap (19). Remove the the top clutch cone (17), loosen the lid cover bolts (8) on the chain pipe cover (1) and remove both parts. Pull away the pressure finger (3) from the gypsy (18) and remove the gypsy.

Clean all the parts removed to avoid corrosion, and grease the shaft (10/11) and the gypsy (18) where the clutch cones rest (17). Use grease suitable for the marine environment

WARNING

MAKE SURE THE ELECTRICAL POWER TO THE MOTOR IS SHUT OFF WHEN WORKING ON THE WINDLASS. CAREFULLY REMOVE THE CHAIN OR ROPE FROM THE GYPSY OR THE ROPE FROM THE DRUM.

Anchorlift windlasses are designed to operate both with chain and DB rope and 3 strand nylon rope. The table below shows a selection of chain and rope that will fit the Anchorlift windlasses.

NOTE !

The chain or rope / chain combination you prefer to use on the windlass has to be specified on order. Before use please make sure that you have the correct gypsy for the chain or rope chain combination you have chosen.

Model:	Gypsy 1:	Gypsy 2:	Gypsy 3:	Rope:
Barracuda	5-6mm DIN766	7mm DIN766 - 1/4" HT	N/A	12-13mm - 1/2"
Dolphin	8mm DIN766	10mm DIN766 - 5/16"HT	N/A	14-16mm - 9/16" - 5/8"
Mako	8mm DIN766	10mm DIN766 - 5/16"HT	3/8"HT	16mm - 5/8"
Aquarius	10mm ISO	12-13mm DIN766	1/2" HT	N/A
Stingray	6mm DIN766	7mm DIN766 - 1/4" HT	N/A	12-13mm - 1/2"

Anchorlift Original Chain. Europe Standard.

Model:	Size	Weight pr. mt	Dimensions Inside	Breaking load	Windlass Model
2005	5 mm	0.52 kg	18,5 x 7 mm	1300 kg	Barracuda
2006	6 mm	0.81 kg	18,5 x 8 mm	1800 kg	Barracuda Stingray Dolphin
2007	7 mm	1.06 kg	21 x 9 mm	2550 kg	Barracuda Stingray Dolphin
2008	8 mm	1.4 kg	24 x 10 mm	3300 kg	Dolphin Mako
2010	10 mm	2.34 kg	28 x 14 mm	5000 kg	Mako Aquarius
2013	13 mm	4.02 kg	36 x 18 mm	8600 kg	Aquarius
2014	14mm	4,53kg	41 x 19mm	9500 kg	Aquarius

Anchorlift Original Chain. USA and Canada Standard.

Model	Size	Weight pr ft.	Dimensions Inside	Breaking Load	Windlass Model
HT1/4"	1/4"	0,74 Lbs	0,845 X 0,41"	6700 Lbs.	Barracuda Stingray
HT5/16"	5/16"	1,03 Lbs	1,03 X 0,51"	8900 Lbs	Dolphin Mako
HT3/8"	3/8"	1,48 Lbs	1,22 X 0,59"	13500 Lbs	Mako Aquarius
HT1/2"	1/2"	2,57lbs	1,59 X 0,76"	25000 Lbs	Aquarius



With USA and Canada Standard Galvanized HT Chain

Model Number	Rope	Length	Chain	Length	Total	Fits Windlass	
DB1/2-150	1/2" / 12mm	150ft / 45m	1/4" / 7mm	15ft / 4,5m	165ft / 50m	Barracuda	Stingray
DB1/2-200	1/2" / 12mm	200ft / 60m	1/4" / 7mm	15ft / 4,5m	215ft / 65m	Barracuda	Stingray
DB1/2-250	1/2" / 12mm	250ft / 75m	1/4" / 7mm	15ft / 4,5m	265ft / 80m	Barracuda	Stingray
DB1/2-300	1/2" / 12mm	300ft / 90m	1/4" / 7mm	20ft / 6m	320ft / 97m	Barracuda	Stingray
DB9/16-150	9/16" / 14mm	150ft / 45m	5/16" / 8mm	15ft / 4,5m	165ft / 50m	Dolphin	
DB9/16-200	9/16" / 14mm	200ft / 60m	5/16" / 8mm	15ft / 4,5m	215ft / 65m	Dolphin	
DB9/16-250	9/16" / 14mm	250ft / 75m	5/16" / 8mm	15ft / 4,5m	265ft / 80m	Dolphin	
DB9/16-300	9/16" / 14mm	300ft / 90m	5/16" / 8mm	20ft / 6m	320ft / 97m	Dolphin	
DB5/8-150	5/8" / 16mm	150ft / 45m	5/16" / 8mm	15ft / 4,5m	165ft / 50m	Mako 1200	Mako 1500
DB5/8-200	5/8" / 16mm	200ft / 60m	5/16" / 8mm	15ft / 4,5m	215ft / 65m	Mako 1200	Mako 1500
DB5/8-250	5/8" / 16mm	250ft / 75m	5/16" / 8mm	20ft / 6m	270ft / 82m	Mako 1200	Mako 1500
DB5/8-300	5/8" / 16mm	300ft / 90m	5/16" / 8mm	20ft / 6m	320ft / 97m	Mako 1200	Mako 1500
DB3/8-150	5/8" / 16mm	150ft / 45m	3/8" / 10mm	15ft / 4,5m	165ft / 50m	Mako 1500	
DB3/8-200	5/8" / 16mm	200ft / 60m	3/8" / 10mm	15ft / 5m	215ft / 65m	Mako 1500	
DB3/8-250	5/8" / 16mm	250ft / 75m	3/8" / 10mm	20ft / 6m	270ft / 82m	Mako 1500	
DB3/8-300	5/8" / 16mm	300ft / 90m	3/8" / 10mm	20ft / 6m	320ft / 97m	Mako 1500	

With AISI 316 Stainless Steel Chain

SSDB1/2-150	1/2" / 12mm)	150ft / 45m	1/4" / 7mm	15ft / 4,5m	165ft / 50m	Barracuda	Stingray
SSDB1/2-200	1/2" / 12mm	200ft / 65m	1/4" / 7mm	15ft / 4,5m	215ft / 65m	Barracuda	Stingray
SSDB9/16-200	9/16" / 14mm	200ft / 60m	5/16" / 8mm	15ft / 4,5m	215ft / 65m	Dolphin	
SSDB5/8-200	5/8" / 16mm	200ft / 60m)	5/16" / 8mm	15ft / 4,5m	215ft / 65m	Mako 1200	Mako 1500
SSDB5/8-250	5/8" / 16mm	250ft / 75m	5/16" / 8mm	20ft / 6m	270ft / 82m	Mako 1200	Mako 1500
SSDB3/8-200	5/8" / 16mm	200ft / 60m	3/8" / 10mm	15ft / 4,5m	215ft / 65m	Mako 1500	
SSDB3/8-250	5/8" / 16mm	250ft / 75m	3/8" / 10mm	20ft / 6m	270ft / 82m	Mako 1500	



Anchorlift limited warranty

Anchorlift warrants its product in normal usage to be free of defects in materials and workmanship for a period of five year from date of purchase by the original purchaser, subject to the conditions, limitations and exceptions listed below. Any part, which proves to be defective in normal usage during that five year period, will be repaired or at Anchorlift's option, replaced by Anchorlift.

Conditions & Limitations

Anchorlift's liability shall be limited to repair or replacement of The goods or parts defective in materials or workmanship.

Determination of the suitability of the material for the use

contemplated by the buyer is the sole responsibility of the buyer and Anchorlift shall have no responsibility in connection with such suitability.

Anchorlift shall not be liable in any way for:

1. Failures, loss or damage due to use of products in applications for which they are not intended.
2. Failures, loss or damage due to corrosion, ultra violet Degradation, wear and tear or improper installation.
3. Failures, loss or damage due to incorrect maintenance.
4. Failures, loss or damage due to conditions that exceed the product's performance specifications, and water damage.
5. Product subject to warranty claim must be returned to Anchorlift or examination unless otherwise agreed by Anchorlift in writing.
6. Anchorlift shall not be responsible for shipping charges nor installation labour associated with any warranty claim.
7. Service by anyone other than authorised Anchorlift representatives shall void this warranty.
8. Anchorlift's products are intended for use only for marine purposes. Buyers intending to use them for any other purpose should seek advice from Anchorlift, and Anchorlift shall be under no liability arising from used, which Anchorlift has not approved.

Exceptions.

Warranty is limited to a period of one year from the date of purchase for the following items

1. Rope / Chain combinations..
2. Gear & electrical motors
3. Electrical equipment
4. Electronical controls

Liability.

Anchorlift's liability under this warranty shall be the exclusion of all other warranties or liabilities (to the extent permitted by law.) In particular (but without limitation.)

1. Any indirect or consequential loss including (without limitation) any loss of anticipated profits, damage to reputation of goodwill, loss of expected future business, damages, costs or expenses payable to any third party or any other indirect losses.
2. Any damage to the yachts or equipment.
3. Death or personal injury (Unless caused by Anchorlift's negligence.
4. Water damage to gear, electrical motor, electrical equipment and electronical controls

Anchorlift shall not be liable for

1. Anchorlift grants no warranties regarding the fitness for purpose, use, nature or satisfactory quality of the goods.
2. Where the laws of the country do not permit a warranty to be excluded, then such warranty, if permitted by the countries law, shall be limited to a period of one year.
3. Any dispute between Anchorlift and other parties shall be solved in a Norwegian court of law.

Severance of clause

If any clause of these warranties is held by any competent Authority to be invalid or unenforceable in whole or in part Of the validity of the the clause of this warranty and the Remainder of the clause in question shall not be affected.

This warranty gives you specific legal rights, and you may also have other legal rights, which vary from country to country.

Anchorlift reserves the right to alter design and specifications without prior notice

5-year factory warranty applies only to products purchased through authorized ANCHORLIFT dealer. Save your receipt, this counts as proof of purchase.

Complete Windlass System

Barracuda

Chain:
6-7-1/4"
Rope:
12-13-1/2"
Boats to:
35ft.



90101
Anchors:
13-22lbs 5-10kg



Control Units

90801



90800



Dolphin

Chain:
7-8-1/4"-5/16"
Rope:
12-14mm
9/16-5/8"
Boats to:
45ft.



90102
Anchors:
17-33lbs 8-15kg



90900B

90060-90175

Mako

Chain:
8-10mm
5/16-3/8"
Rope:
16mm 5/8"
Boats to:
65ft



90103
Anchors:
22-44lbs 10-20kg



90503

90501



Mako C

Chain:
8-10mm
5/16-3/8"
Rope:
16mm 5/8"
Boats to:
65ft



90105
Anchors:
66-110lbs 30-50kg



"AutoDrop" 4ch Radio Remote 91354



90126
Anchors:
17-44lbs 8-20kg



Aquarius C

Chain:
10-12-13mm
3/8"-1/2"
Boats to:
90ft



XR Anchors Size 6 to 80
Stainless steel Boats 20 to 90ft



Rope ChainCombo
Double Braid Nylon Rope
Galvanized or Stainless steel chain.
1/4" Chain 1/2" rope
5/16" chain 9/16" rope
5/16" Chain 5/8" rope
3/8" rope 5/8" rope

Chain to anchor swivel connectors

964408 Chain

5-6-7mm 1/4"

964410 Chain

8-10mm 5/16-3/8"

964412 Chain

10-13mm 3/8-1/2"

964420 Chain

13-19mm 1/2-3/4"



Plow Anchors 18lbs to 110lbs
Stainless Steel 6 - 50kg



Bow Plank Rollers



90128

90114



90127

Chain Galvanized and Stainless Steel

Europe std: 5-6-7-8-10-13-14mm

USA Standard: 1/4 - 5/16 - 3/8 - 1/2"



Original chain HT43.

