



Greenline HT Plus C and E



Guide to installation, commissioning and maintenance

Art. no: 290410-29

Version: 1.1



FOR THE USER

FOR THE INSTALLER

INDEX

Thank you for choosing a heat pump from IVT Industrier AB

We hope that our heat pump meets your expectations and gives you many years of energy saving. We want you and your family to enjoy a good economy at the same time as you actively safeguard the environment. We have taken today's demands on heat pumps into consideration and believe that your Greenline HT will give you many useful functions in the future. Your heat pump features an advanced control unit that monitors and controls the temperature in the house and contributes towards improved overall economy. The heat pump Greenline HT Plus has, for example, a holiday function, that's to say the heat pump can be set at a "low level" while you are away on holiday.

IVT is the leading heat pump manufacturer in the Nordic Countries. More than every second heat pump comes from IVT. We have worked with solutions to reduce energy consumption on the environment's terms for more than 30 years. Today we can present the widest range of heat pumps for efficient energy saving in all types of housing and properties.



A handwritten signature in dark ink, appearing to read 'Johnny Wärnelöv'.

Johnny Wärnelöv
Managing director IVT Industrier AB

Manual for Heat pump Greenline HT Plus C and E
IVT Industrier AB, 20.12.04
Article number: 290410-29
Version 1.1

Copyright © 2004. IVT Industrier AB. All rights reserved.

This manual contains copyright protected information that is the property of IVT Industrier AB. No part of this document may be copied or forwarded, electronically or mechanically, without prior, written permission from IVT Industrier AB. This includes photographing and translation to another language.

Contents

FOR THE USER	5
Important information.....	5
This is how your heat pump works	6
<i>Technology in and around the heat pump.....</i>	<i>6</i>
Component parts of the heat pump	8
<i>IVT Greenline HT Plus C.....</i>	<i>8</i>
<i>IVT Greenline HT Plus E.....</i>	<i>9</i>
Control unit Rego 637	10
<i>The control unit's two methods to control the heat pump.....</i>	<i>11</i>
Control panel.....	12
<i>Controls and status lamps</i>	<i>12</i>
<i>Menu dial</i>	<i>13</i>
<i>How to use the control panel</i>	<i>13</i>
Basic functions (Customer level 1)	13
<i>Menu overview for Basic functions (Customer level 1).....</i>	<i>14</i>
<i>Select scrolling information on the menu display.....</i>	<i>14</i>
<i>Set the heating</i>	<i>15</i>
<i>Set the desired room temperature</i>	<i>18</i>
<i>Set the heat pump for extra hot water</i>	<i>18</i>
<i>Heating- and hot water settings</i>	<i>19</i>
<i>Read the temperatures on the heat pump.....</i>	<i>19</i>
Extra functions (Customer level 2)	21
<i>Menu outline for Extra functions (Customer level 2).....</i>	<i>21</i>
<i>Temperature settings.....</i>	<i>22</i>
<i>Set extra heat curve with mixing valve</i>	<i>23</i>
<i>Hot water settings</i>	<i>24</i>
<i>Timer control.....</i>	<i>24</i>
<i>Reading operating times on the heat pump and additional heat</i>	<i>25</i>
<i>Set the time and date</i>	<i>26</i>
<i>Alarms given by the heat pump</i>	<i>27</i>
<i>Return to the heat pump's factory settings.....</i>	<i>27</i>
Care.....	28
<i>Unscrew the front cover</i>	<i>28</i>
<i>Sight glass.....</i>	<i>28</i>
<i>Expansion tank</i>	<i>29</i>
<i>Particle filter.....</i>	<i>30</i>
<i>Checking the protective anode</i>	<i>30</i>
Savings	31
What to do if a fault occurs	32
<i>Dimmed menu display</i>	<i>32</i>
<i>Fuses and reset buttons on the heat pump.....</i>	<i>33</i>
<i>All Alarm.....</i>	<i>33</i>

FOR THE INSTALLER	40
Important information to the installer.....	41
Checklist.....	41
What the shipment includes.....	42
Dimensions and connections	43
The heat pump and collector hose in general.....	44
<i>Transporting the heat pump.....</i>	<i>44</i>
<i>Positioning the heat pump.....</i>	<i>44</i>
<i>Maximum working temperatures</i>	<i>44</i>
<i>Fit the particle filter.....</i>	<i>44</i>
<i>Collector hose.....</i>	<i>45</i>
Preparations before connection.....	48
<i>Moving the heat transfer fluid pipe for side entry.....</i>	<i>48</i>
<i>Supplementing the heat pump with a ground water system.....</i>	<i>51</i>
<i>Ground water system: Electrical connection</i>	<i>52</i>
Connecting the heat pump to the heating system	52
<i>Connecting to the heating system without a bypass:.....</i>	<i>53</i>
<i>Connect heat pump C to the heating system</i>	<i>54</i>
<i>Connect heat pump E to the heating system</i>	<i>55</i>
<i>Connect the heat pump to a heating system with bypass</i>	<i>56</i>
<i>Filling water in the heating system</i>	<i>57</i>
<i>Filling the heat transfer fluid in the collector hose</i>	<i>57</i>
<i>Installing the expansion vessel.....</i>	<i>59</i>
Connecting the heat pump to the power supply	60
<i>Safety switch and earth-fault breaker.....</i>	<i>60</i>
<i>External connections to the heat pump.....</i>	<i>61</i>
<i>Connecting the general alarm, external input and load monitor.....</i>	<i>62</i>
Installer and service menu (I/S)	63
<i>How to use the control panel</i>	<i>63</i>
Commissioning the heat pump.....	64
<i>Menu displays you might need to adjust or check.....</i>	<i>65</i>
<i>Manual test run of the heat pump.....</i>	<i>68</i>
<i>Start the heat pump with only additional heat</i>	<i>68</i>
<i>Important points to check after start up.....</i>	<i>68</i>
Technical information.....	69
<i>The heat pump's factory settings.....</i>	<i>69</i>
<i>Sensor table.....</i>	<i>69</i>
<i>Technical information.....</i>	<i>70</i>
Index	71

For the user

Important information

The heat pump Greenline HT Plus represents a new generation of heat pumps from IVT Industrier. It contains numerous functions to control the temperature and production of hot water in the house. The control unit Rego 637 is the brains of the heat pump. Rego 637 includes a control and monitoring function that stores important settings about the heat pump's operation and maintenance. The settings are made by the installer and the user via a control panel on the front of the heat pump. Settings intended for the user, are presented in this chapter under the headings *Basic functions* and *Extra functions*.

When the heat pump has been installed and started there are a number of points you should check regularly. This may concern an alarm triggering or performing basic maintenance actions. Initially you should perform these actions on your own. This manual describes each step in detail. If the problem remains you should contact your dealer.



Note

It is important as the user that you read through the User manual. Under no circumstances may the user make settings that are designed for the installer. This can cause serious malfunction of the heat pump.

This is how your heat pump works

The heat pump collects stored solar energy

The heat pump Greenline HT Plus represents a new generation of heat pumps from IVT Industrier. The heat pump has been manufactured for easy and reliable use as well as to provide your house with inexpensive and environment friendly heating. The easiest way to describe how a heat pump works is to say it works like a refrigerator, however, the other way round. In a refrigerator, heat is moved from the inside to the outside. In a heat pump, heat stored in the ground, rock or water, is moved into the house. The heat pump collects a few degrees of the stored solar energy. The heat is led into the house via a hose. The temperature is then increased in the heat pump and the heat is distributed to the house's heating system.

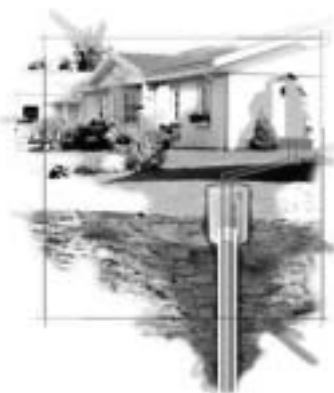

Rock heat



Soil heat



Lake heat

Technology in and around the heat pump

The heat pump consists of four main parts:

1. **Evaporator**
Evaporates the refrigerant to gas and at the same time transfers the heat from the heat transfer fluid to the refrigerant circuit.
2. **Condenser**
Condenses the gas to fluid again and transfers the heat to the heating system.
3. **Expansion valve**
Lowers the pressure of the refrigerant.
4. **Compressor**
Increases the pressure of the refrigerant.

These four main parts are linked in three circuits. A refrigerant circulates in the heat pump, which in some parts of the circuit is in a liquid state and in other parts in a gas state. Read more about the properties of the refrigerant in the sidebar to the right.

See the detailed description of the technologies used in the heat pump on the next page.



Note

Boiling point in relation to the pressure:

The boiling point of different liquids varies with pressure, the higher the pressure, the higher the boiling point. For example, water boils at +100°C at normal pressure. Double the pressure and water boils at +120°C. Half the pressure and water then boils at +80°C. The refrigerant in the heat pump acts in the same way, the boiling point changes when the pressure changes. However, the boiling point of the refrigerant is as low as approximately -40°C at atmospheric pressure. Consequently, it is also suitable for low heat source temperatures.

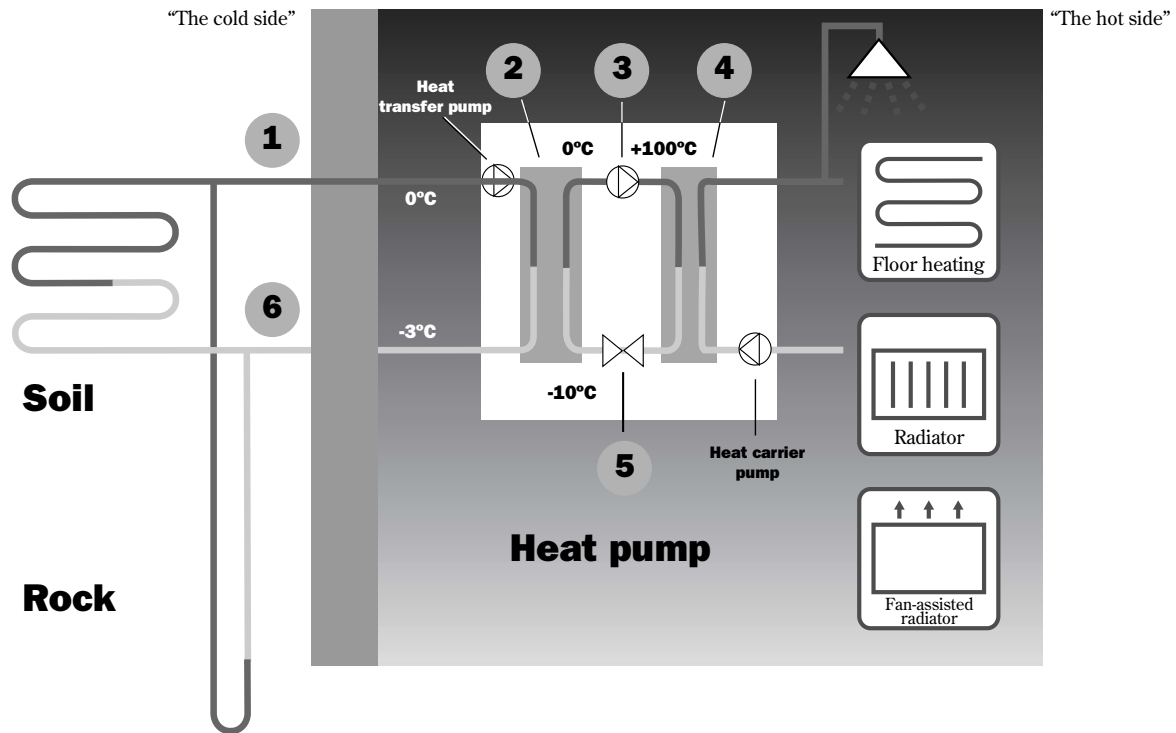

- 1** Heat transfer fluid in. A hose is connected here that collects the stored solar energy from, e.g., the soil or rock. The hose contains a heat transfer fluid, which is a mixture of water and anti-freeze. The fluid collects the heat from the rock and with the help of the HTF pump leads it into the heat pump and the evaporator. The temperature is then approximately 0°C .
- 2** In the evaporator, the heat transfer fluid meets the refrigerant. At this stage, the refrigerant is in a fluid state and is at approximately -10°C . When the refrigerant meets the zero degree heat transfer fluid it starts to boil. It then forms a vapour, which is led into the compressor. The temperature of the vapour is 0°C .
- 3** The pressure of the refrigerant increases in the compressor and the vapour temperature rises from 0°C to approximately $+100^{\circ}\text{C}$. The warm gas is then forced into the condenser.
- 4** The condenser is the heat pump's heat emitting part. Here the heat is transferred to the house's heating system (radiators and floor heating) and the hot water system. The vapour is cooled in the condenser and becomes fluid. The pressure in the refrigerant is still high when it is led on to the expansion valve.
- 5** The refrigerant pressure is lowered in the expansion valve. At the same time, the temperature also drops to approximately -10°C . When the refrigerant has passed through the valve and the evaporator it changes to vapour again.
- 6** In heat transfer fluid out, the heat transfer fluid is led out from the heat pump to the rock to collect new stored solar energy. The temperature of the fluid is approximately -3°C .

Component parts of the heat pump

IVT Greenline HT Plus C

Three-way valve

The valve switches between heating the heating water and hot water.

Hot water cylinder

The cylinder is double-shelled and holds approximately 165 litres of hot water and 60 litres of the heating water.

Electric water heater

The electric cassette is used to provide extra output in cold weather conditions, with large water consumption and at hot water peaks.

Reset button

Press in the button if the overheat protector on the electric cassette has tripped. The button is located on the side.

Condenser

The condenser condenses the vapour to fluid again and transfers the heat to the heating system.

Heat carrier pump

The pump ensures the heating water circulates within the heating system.

Compressor

The compressor increases the pressure of the refrigerant. The temperature of the vapour increases from 0°C to approximately +100°C. The compressor is insulated to reduce the noise level.

Flexible hoses

The hoses counteract vibrations in the heat pump.

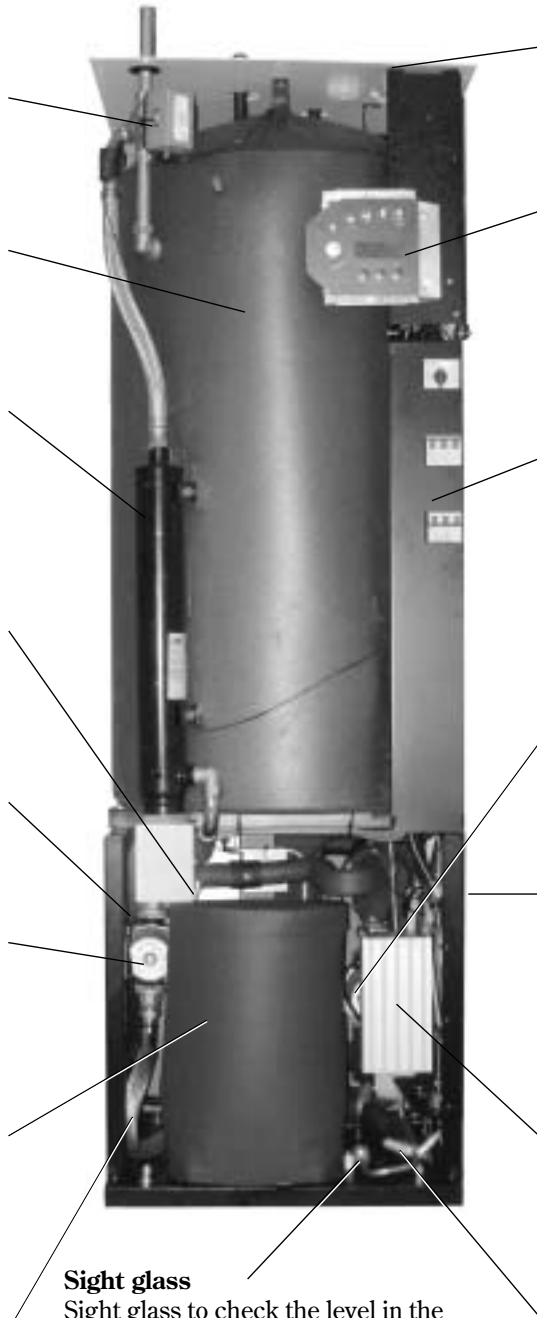

Electrical connections

Connections for the mains supply as well as sensors.

Control panel

The control panel has a background lit menu display with four rows of text information, three buttons and a dial.

Electrical box

The distribution box is enclosed. It houses a reset function for the motor cut-out as well as miniature circuit breakers (MCB) for the heat pump and electric cassette.

Heat transfer fluid pump

The pump is insulated and features an anti-corrosive finish. It ensures the heat transfer fluid circulates from, e.g. the rock to the heat pump.

Evaporator

The evaporator evaporates the refrigerant to gas and transfers heat from the heat transfer fluid to the refrigerant circuit (behind the heat pump).

Control unit

The control unit is enclosed. It controls and monitors all heat pump functions.

Expansion valve

Lowers the pressure of the refrigerant that enters the evaporator and collects energy from, e.g. the rock.

Sight glass

Sight glass to check the level in the refrigerant circuit. Air bubbles must not form in the sight glass when the heat pump is running. However, there might be bubbles when the heat pump is started and stopped.

IVT Greenline HT Plus E

Three-way valve

The valve switches between heating the heating water and hot water.

Particle filter

The filter can be opened for easy cleaning. It also has a shut off function.

Electric water heater

The electric cassette is used to provide extra output in cold weather conditions, with large water consumption and at hot water peaks.

Reset button

Press in the button if the overheat protector on the electric cassette has tripped. The button is located on the side.

Condenser

The condenser condenses the vapour to fluid again and transfers the heat to the heating system.

Heat carrier pump

The pump ensures the heating water circulates within the heating system.

Flexible hoses

The hoses counteract vibrations in the heat pump.

Compressor

The compressor increases the pressure of the refrigerant. The temperature of the vapour increases from 0°C to approximately +100°C. The compressor is insulated to reduce the noise level.

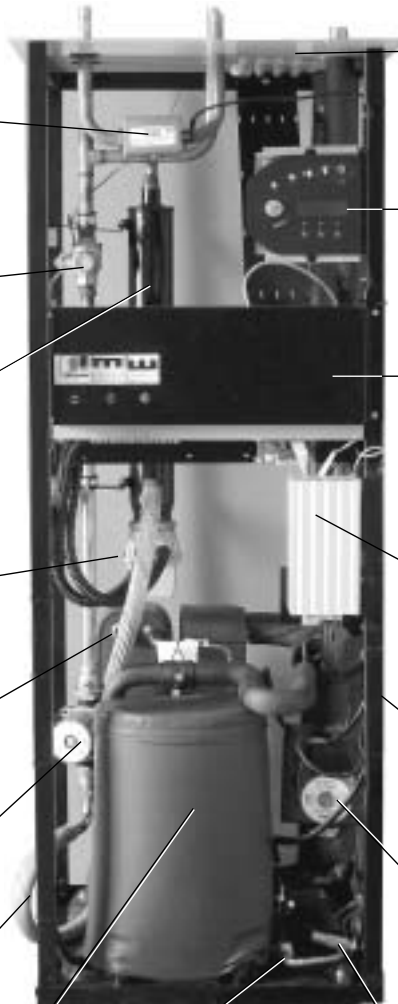

Electrical connections

Connections for the mains supply as well as sensors.

Control panel

The control panel has a background lit menu display with four rows of text information, three buttons and a dial.

Electrical box

The distribution box is enclosed. It houses a reset function for the motor cut-out as well as miniature circuit breakers (MCB) for the heat pump and electric cassette.

Control unit

The control unit is enclosed. It controls and monitors all heat pump functions.

Evaporator

The evaporator evaporates the refrigerant to gas and transfers heat from the heat transfer fluid to the refrigerant circuit (behind the heat pump).

Heat transfer fluid pump

The pump is insulated and features an anti-corrosive finish. It ensures the heat transfer fluid circulates from, e.g. the rock into the heat pump.

Sight glass

Sight glass to check the level in the refrigerant circuit. Air bubbles must not form in the sight glass when the heat pump is running. However, there might be bubbles when the heat pump is started and stopped.

Expansion valve

Lowers the pressure of the refrigerant that enters the evaporator and collects energy from, e.g. the rock.

Control unit Rego 637

The control unit is the brains of the heat pump. It makes sure the heat pump gives the best energy savings and that it runs for many years. The control unit controls and monitors the heating and hot water supply in your house. The monitoring function is especially important. It shuts down the heat pump in the event of operational disturbances so that no critical parts are damaged.

Additional heat gives more output

When the heat pump can not manage to heat the house by itself, for example, if there is a considerable drop in the outdoor temperature, the control unit ensures the additional heat source is connected. Together the heat pump and additional heat guarantee the right temperature in the house. Additional heat in the Greenline HT Plus is provided by a built in electric cassette. Additional heat can never completely take over the heating from the heat pump. It only adds the output necessary for the heat pump to be able to produce the right temperature. When the heat pump can once again manage heating on its own the additional heat is automatically disconnected.

Hot water is given priority over heating water

In a house with water based heating a difference is made between heating water and hot water. The heating water is for radiators/floor heating and hot water is for showers and taps. Hot water is heated in a hot water heater. The hot water heater is fitted with a sensor that senses the temperature of the hot water. C models include a hot water heater in the heat pump while E models have an external hot water heater. The heating water passes through the hot water cylinder's outer shell and heats up the hot water heater's inner tank. The control unit makes sure the heating of hot water is always given priority over the heating of the heating water. This means you never need to be without hot water. The control unit controls a three-way valve that switches between heating the heating water and hot water. Once the hot water has been heated the three-way valve switches so that the heating water is heated.

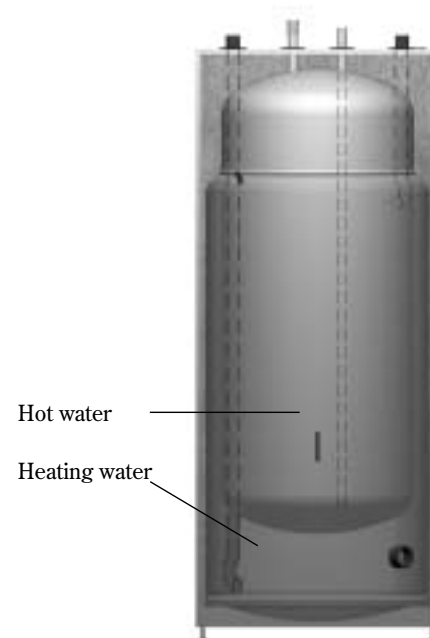
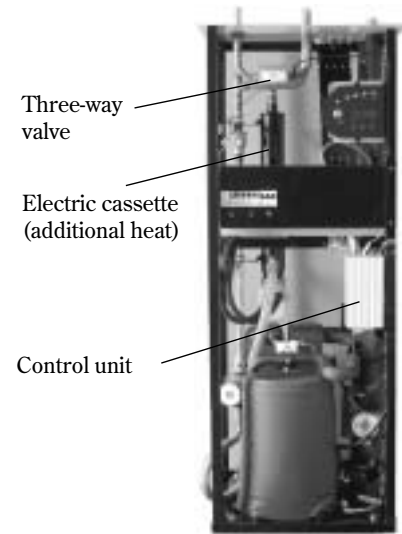

Double-shelled hot water cylinder

The control unit's two methods to control the heat pump

The control unit uses two different methods to control the heat pump. These two methods are: *Control with an outdoor sensor* and *Control with an outdoor sensor supplemented with a room sensor*.

Control with outdoor sensor

Control with an outdoor sensor is the most common method used by the control unit to control the heat pump. When the heat pump is delivered it is set for this control method. A sensor is fitted on the outside wall of the house. It sends signals to the control unit in the heat pump. Control with an outdoor sensor means that the heat pump automatically regulates the heating in the house depending on the outdoor temperature. If the outdoor temperature drops, i.e. it becomes colder; the radiators inside the house will become warmer.

You determine the temperature of the radiators, in relation to the outdoor temperature, with the help of a number of settings such as selecting the heat curve on the control unit. A lower curve gives higher energy savings.

Control with an outdoor sensor supplemented with room sensor

Control with an outdoor sensor supplemented with a room sensor means that you also place a sensor in a central position inside the house. This is connected to the heat pump and provides the control unit with information about the room temperature. The signals affect the control unit's settings (curves) and ensure the heat pump gives the best possible energy savings.

This control method is used when factors other than the outdoor temperature influence the indoor temperature. Examples include the use of a stove or fan-assisted radiator or if the house is sensitive to the wind.



Note

It is only the room where the room sensor is located that can influence regulation of the temperature.

Control panel

All settings are made from the control panel. It also displays heat production statistics and information about different alarms. When you have made your settings, the control panel makes sure they are saved in the control unit Rego 637 to carry out your wishes.

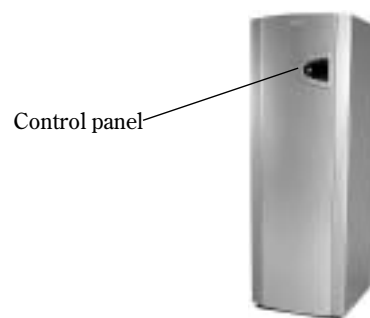

Control panel

Controls and status lamps



Power switch (ON/OFF)

You start and stop the heat pump using the power switch button.

Lamp on: The heat pump is on.

Lamp flashes: The heat pump is off.



Operating status

Lamp on: The heat pump (compressor) is operational.



Additional heat status

Lamp on: The heat pump is using additional heat from an electric cassette.



Hot water status

Lamp on: The heat pump is heating water in the heater.

Lamp flashes: The heat pump has a hot water peak or is producing extra hot water.



Alarm status

Lamp flashes: A fault has occurred in the heat pump.

Lamp on: The alarm has been acknowledged, but the fault remains.

Temperature



Temperature

Pressing once gives a shortcut to the most frequent temperature settings.

Info



Info

Pressing once gives continuous information about the heat pump's and additional heat's operating conditions.

Menu



Menu

Press once to enter the main menu.

The main menu contains all setting menus and temperature displays.

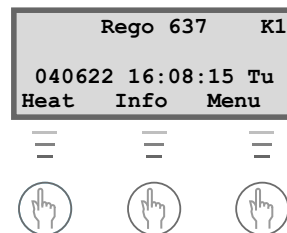
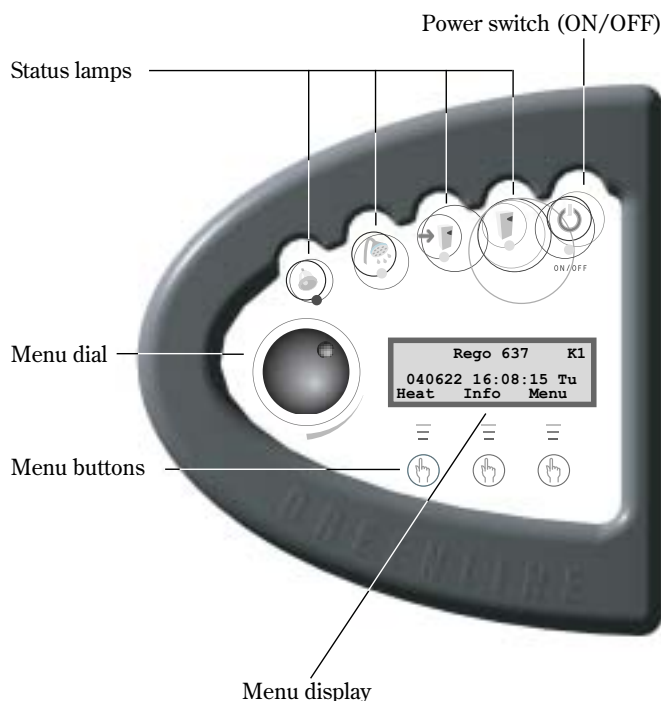

Menu dial

The menu dial is used to scroll through the menu display windows. Turn the menu dial clockwise (to the right) to move down through the menus. Turn the menu dial anti-clockwise (to the left) to move up through the menus. You also determine the values of different settings by using the dial.



The menu display gives you information and the chance to make settings. You can:

- Choose different temperature and hot water settings.
- Choose extra hot water and the holiday function.
- See alarm causes and receive corrective instructions.
- Obtain operating statistics.

Initial menu display

Rego 637		K1
040622	16:08:15	Tu
Heat	Info	Menu

How to use the control panel

The principle of the control panel is based on the user using three menu buttons and a menu dial to move between the different menus and settings. On the lower row of the menu display you will always see information about the significance of the buttons. The function of the buttons changes depending on which window you are currently in.

Example

If, from the initial menu, you press the Heat button, you will access the menu *Temp. incr. / decr.* In this menu you can increase and decrease the heating in the house. Note that the significance of the buttons has now changed. You can either return to the initial menu by pressing the Return button or you can choose to change the heating setting in the house by pressing the Adjust button. If you press the Adjust button you can increase or decrease the heating in the house by using the menu dial. Save your adjustment by pressing the Save button.



+

Initial menu

Rego 637		K1
040622	16:08:15	Tu
Heat	Info	Menu

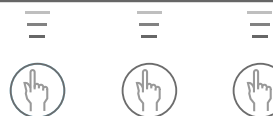

Temp. incr. / decr.		
0	5,0	10
Return	Adjust	

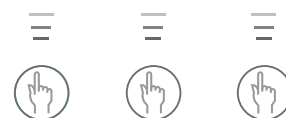

Basic functions (Customer level 1)

Basic functions (Customer level 1) are the functions most frequently used and the ones you have the most benefit of. You reach the basic functions by pressing one of the Heat, Info or Menu buttons in the initial menu. The designation K1 in the upper right corner indicates you are in *Basic functions – Customer level 1*.

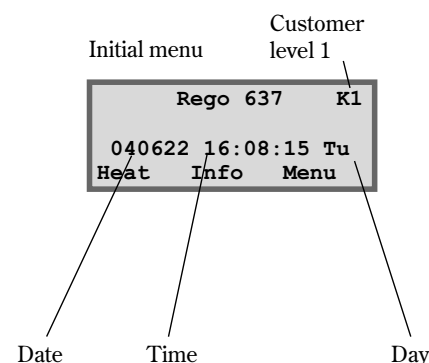

Menu overview for Basic functions (Customer level 1)

Note
Each menu is numbered in the lower right-hand corner; this indicates which main display it is associated to.

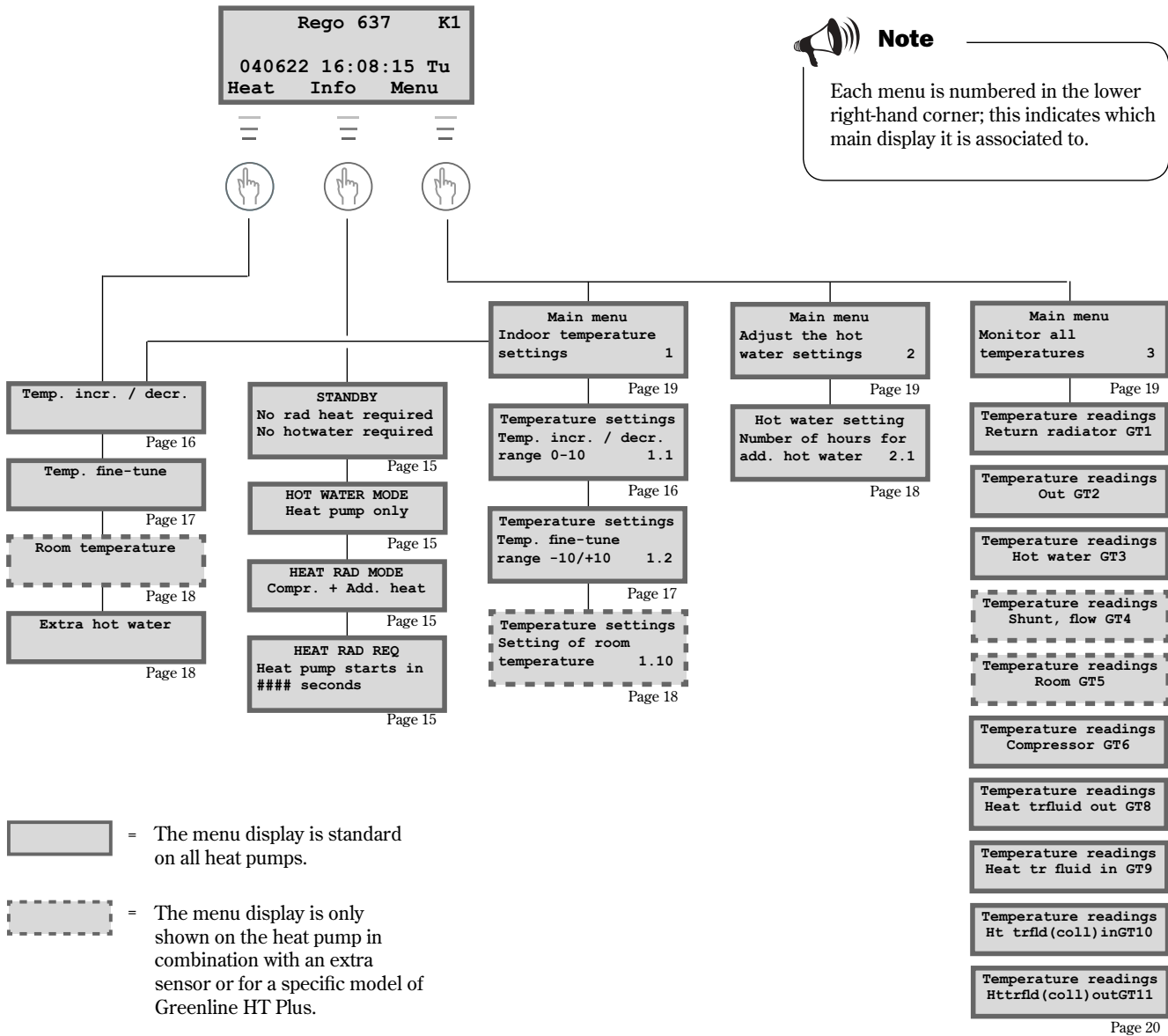

Select scrolling information on the menu display

If you press the Info button in the initial menu, you will receive continuous information about the heat pump's operation and working temperatures. This is what to do:

1. Press the Info button in the initial menu. Here follows a few of the windows displayed:

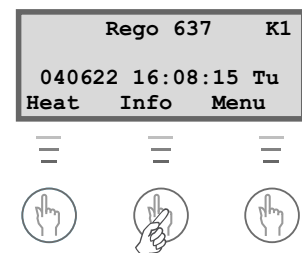

The heat pump is in standby mode.

STANDBY
No rad heat required
No hotwater required

The heat pump is producing hot water. You see at which temperature the heat pump will stop and the present temperature. Note that the stop temperature is read at the bottom of the heater. The hot water is a few degrees warmer.

HOT WATER MODE
Heat pump only
Stop temp 53.0°
Present temp 50.0°

The heat pump and additional heat are running.

HEAT RAD MODE
Compr. + Add. heat
Stop temp 45.0°
Present temp 44.0°

The heat pump has received signals that it should produce heating. It now waits for the restart time to countdown to zero.

HEAT RAD REQ
Heat pump starts
in 320 seconds

Return to the initial menu by pressing one of the buttons or turn the dial.

Set the heating

It is easy to set the heating level on the heat pump. However, before we explain how to do this it is important to understand the relation between the outdoor temperature, return temperature and heat curve slope. The easiest way to explain the relation is with a heat curve.

Heat curve

You use the heat curve to help set the indoor temperature you would like. The heat pump is controlled by the outdoor temperature. When the weather becomes colder, the heat pump ensures more heating is produced automatically.

Return temperature:

The return temperature is the temperature of the water that returns to the heat pump from the radiators. The water led out from the heat pump to the heating system is normally 7-10°C higher than the return temperature. When the outdoor temperature is -10°C and curve 4 is set, the pump attempts to keep the return water at approximately 40°C.

Outdoor temperature:

The outdoor temperature determines how much heating the heat pump should produce. A sensor placed outdoors sends signals to the control unit, which then adjusts the heat pump.

Curve slope:

You can change the curve slope to increase or decrease the heating in the house. The scale is between 0-10.



Note

On delivery the heat pump curve slope is set to position 4. This means that the return temperature is +35°C when it is 0°C outdoors.

Change the curve slope

The heat pump's production of heating is adjusted by increasing or decreasing the curve slope in the Temp. incr. / decr. menu. This is especially effective in cold weather conditions.

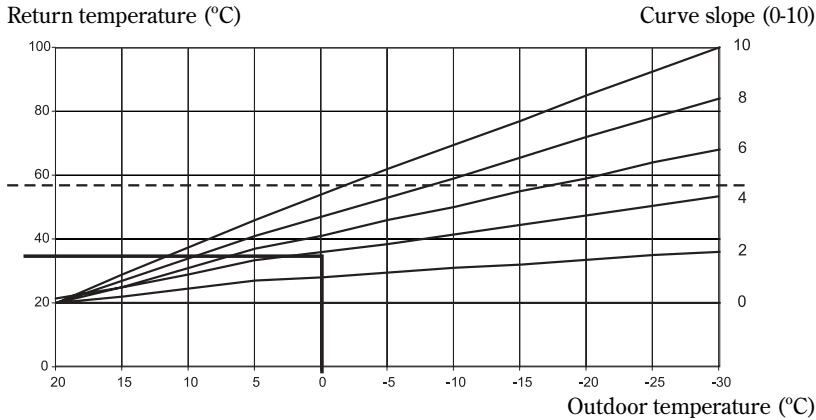

Dashed line:

If the return temperature exceeds 57°C an alarm is given and the compressor switches off. The heat pump starts automatically when the return temperature drops.

Curve slope:

- 2-4 Normal setting for floor heating.
- 4-6,5 Normal setting for radiators.
- 7-10 Abnormal high setting.

From the heat curve we see that curve slope 4 gives a return temperature of +35°C when it is 0°C outdoors. If the outdoor temperature drops we can see that the return temperature increases. The colder the outdoor temperature the higher the return temperature. At an outdoor temperature of approximately -30°C we see the curve slope has nearly reached the limit value (+57°C) for the return temperature.

In cold weather (below -5°C):

If you are not satisfied with the indoor temperature when it is colder than +5°C outdoors, you need to change the slope of the heat curve. This is what to do:

1. Press the Heat button in the initial menu.

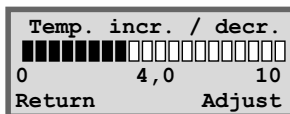

2. Press the Adjust button.
3. Turn the menu dial clockwise to increase the heating. Turn the menu dial anti-clockwise to lower the heating. (Adjust in small increments, 0.2-0.6 units, is usually enough.)

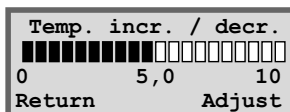

4. Save the new value by pressing the Save button.



Note

You should wait at least two days when increasing or decreasing the heating before making a new adjustment.

If it is still difficult to get a comfortable indoor temperature at an outdoor temperature around 0°C, despite several attempts, you should adapt the heat curve. Read about how to "adapt the curve" in the section *Extra functions – Customer level 2 / Temperature settings / Adapting the heat curve.*

Fine-tune the heat curve

The heat curve can also be fine-tuned. Fine-tuning means that you offset the heat curve in parallel. Fine-tuning is done from the Temp. fine-tune menu. The diagram for fine-tuning shows how the dashed line has been offset upwards in parallel. This means the heating has been fine-tuned in a positive direction and the heat pump will be instructed to maintain a higher temperature on the return water at all outdoor temperatures.

Return temperature (°C)

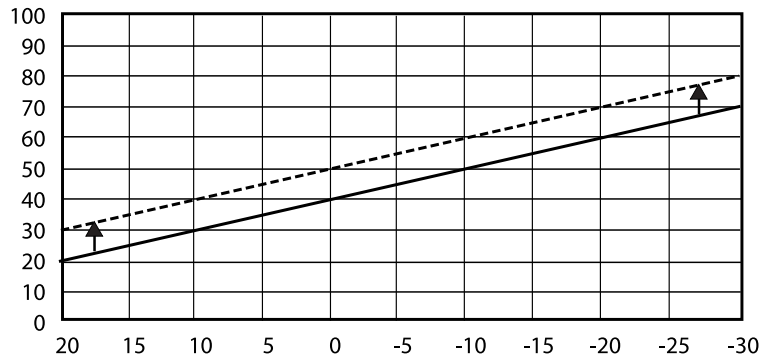

By using the menu dial on the control panel the fine-tuning line has been moved up so the heat pump produces more heat.

In warm weather (above +5°C):

If you are not satisfied with the indoor temperature when it is warmer than +5°C outdoors, you should offset the curve in the Temp. fine-tune menu. This is what to do:

1. Press the Heat button in the initial menu.
2. Turn the menu dial clockwise until you reach the menu *Temp. fine-tune*.

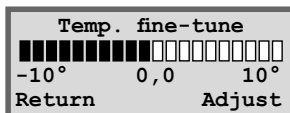

3. Press the Adjust button.
4. Turn the menu dial clockwise to increase the heating.
Turn the menu dial anti-clockwise to lower the heating.
(Adjust in small increments, 0.5-1.0 units, is usually enough.)
5. Save the new value by pressing the Save button.

Set the desired room temperature

If you have a room sensor connected to the heat pump you can set the required temperature in the room from the Room temperature menu. From Extra functions (Customer level 2) you can also set how much you want the sensor to influence the heating system.

This is what to do:

1. Press the Heat button in the initial menu.
2. Turn the menu dial clockwise until you reach the menu *Room temperature*.

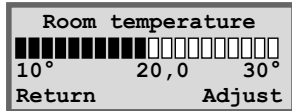

3. Press the Adjust button.
4. Turn the menu dial clockwise to increase the room temperature.
Turn the menu dial anti-clockwise to lower the room temperature.
5. Save the new value by pressing the Save button.

Set the heat pump for extra hot water

You can obtain extra hot water by temporarily increasing the temperature of the water in the hot water cylinder. This may be appropriate when, for example, a large number of people need to shower. You choose how long the function should run using the Extra DHW menu. This is what to do:

1. Press the Heat button in the initial menu.
2. Turn the menu dial clockwise until you reach the menu *Extra DHW*.

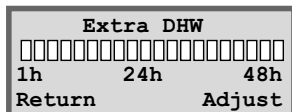

3. Press the Adjust button.
4. Turn the menu dial clockwise to choose the number of hours that the electric cassette should be on (e.g. 24 hours).

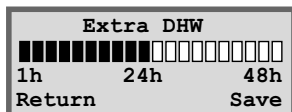

5. Save the value by pressing the Save button.



Note

The example describes how to set the required room temperature with the help of a connected room sensor. The range is 10°C to 30°C.



Note

When the set time has elapsed you must repeat the setting to get extra hot water again.

Heating- and hot water settings

Move to the temperature settings for heating on Customer level 1 like this:

1. Press the Menu button in the initial menu.

```

Main menu
Indoor temperature
settings          1
Return          Select
  
```

2. Press the Select button and scroll through the heating menus with the menu dial.

Move to the temperature settings for hot water on Customer level 1 like this:

1. Turn the menu dial clockwise until you reach the menu *Here you can adjust the hot water settings*.

```

Main menu
Adjusting the hot
water settings    2
Return          Select
  
```

2. Press the Select button and scroll through the hot water menus with the menu dial.

```

Rego 637  K1
040622 16:08:15 Tu
Heat   Info   Menu
  
```

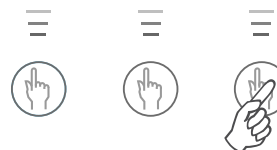

Note

Each menu is numbered in the lower right-hand corner; this indicates which main display it is associated to.

Read the temperatures on the heat pump

There are several different temperature sensors in the heat pump. Each sensor plays an important part in the heat pump's daily operations. It may, for example, adjust the heating production so that the pump does not become overheated. Proceed as follows to read the temperatures on the heat pump:

1. Press the Menu button in the initial menu.
2. Turn the menu dial clockwise until you reach the menu *Here you can monitor all temperatures* (menu 3).

```

Main menu
Monitor all
temperatures      3
Return          Select
  
```

3. Press the Select button.
4. Turn the menu dial to scroll through all the heat pump's temperature sensors. See the next page.

All the temperature sensor menus

All the windows associated with the heat pump's temperature sensors are presented below. Note that you cannot make any settings in these menus, only read the current values. Some menus are standard for all models of Greenline HT Plus while others are only available in combination with different accessories.

The sensors give an alarm if the temperature is outside of the permitted interval/values.

```
Temperature readings
Return radiator GT1
Off 41.3° Now 40.3°
Return
```

The menu shows the temperature in the heating system's return, i.e. the water from the radiators back to the heat pump in heating mode. This temperature varies depending on the outdoor temperature.

```
Temperature readings
Out GT2
14,0°
Return
```

The menu shows the outdoor temperature. Some deviation compared to the true temperature may occur due to thermal radiation from the house to the installed outdoor sensor.

```
Temperature readings
Hot water GT3
Set 51,0° Now 50.0°
Return
```

The menu shows the set and present temperature in the lower section of the outer container in the hot water cylinder. The temperature is approximately 5°C lower than the temperature of the hot water inside the inner container.

```
Temperature readings
Shunt, flow GT4
Tgt 40,3° Now 43.0°
Return
```

The menu only applies together with a flow sensor. If an extra curve with mixing valve is used, for example, for a floor heating system, you can see the temperature on the flow water in the circuit. The temperature varies with the outdoor temperature.

```
Temperature readings
Room GT5
Tgt 20.0° Now 19.5°
Return
```

The menu only applies together with a room sensor. The menu shows the set point value and present temperature in the room where the sensor is fitted.

```
Temperature readings
Compressor GT6
90,0°
Return
```

The menu shows the compressor's working temperature. The temperature varies between 70°C and 125°C during operations.

```
Temperature readings
Heat trfluid out GT8
45,0°
Return
```

The menu shows the temperature of the radiator water as it leaves the heat pump. It varies depending on the outdoor temperature and whether the heat pump is in hot water production mode.

```
Temperature readings
Heat tr fluid in GT9
40,3°
Return
```

The menu shows the temperature of the water that is led into the heat pump. It varies depending on the outdoor temperature and whether the heat pump is in hot water production mode. The heat pump stops at 57°C for reasons of safety.

```
Temperature readings
Ht trfld(coll)inGT10
0,0°
Return
```

The menu shows the temperature of the heat transfer fluid that is led into the heat pump from the bore hole or the ground. It can vary between -5°C to +15°C during a season.

```
Temperature readings
Httrfld(coll)outGT11
-4,0°
Return
```

The menu shows the temperature of the heat transfer fluid that is led out of the heat pump to the bore hole or the ground. Normally, during operations, it is 1.5 - 5.0 degrees lower than the heat transfer fluid that is led into the heat pump.



Note

All sensors are not included as standard on the heat pump, some are available as accessories for different application areas. See more information under respective menus.

Extra functions (Customer level 2)

In the section Basic functions (Customer level 1) we presented the functions that you will probably use the most and which you will receive the most benefit from. However, there are numerous extra functions that you can use to control your heat pump. This can, for example, include activating the heat pump's holiday function or setting the time and date. If no settings are made on Customer level 2 (K2), the menu display will automatically return to Customer level 1 (K1) after 30 minutes. Proceed as follows to access the extra functions on Customer level 2:



1. Press the Heat button until Access = CUSTOMER2 is displayed.
2. Press the Menu button to open the *Main menu* From Customer level 2 you also have access to all Customer level 1 functions.

Menu outline for Extra functions (Customer level 2)

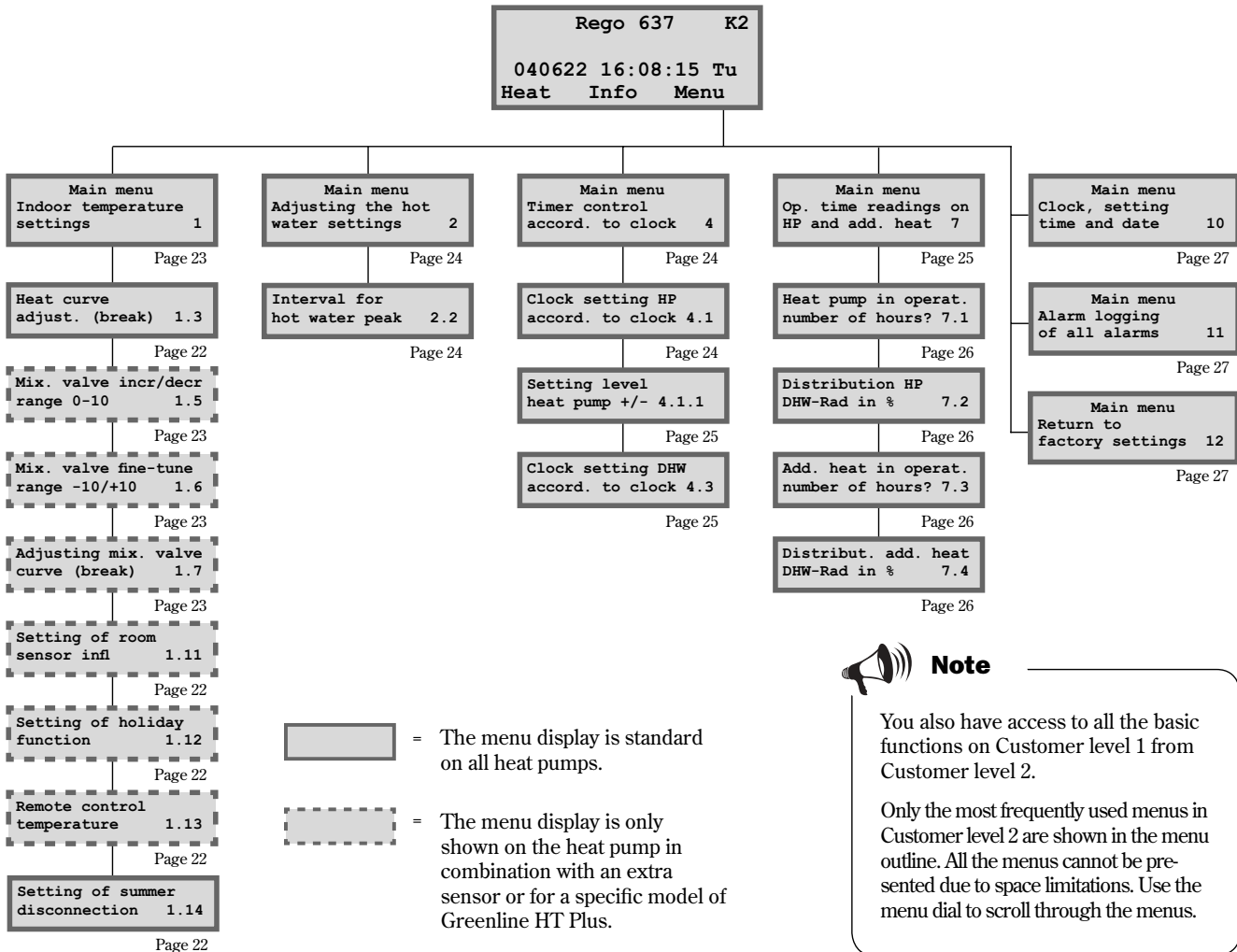

Temperature settings

Proceed as follows to access the temperature settings for the heating on Customer level 2:

1. Press the Heat button until Access = CUSTOMER2 is displayed.
2. Press the Menu button.
3. Press the Select button and scroll through the menus with the menu dial.

```

Main menu
Indoor temperature
settings          1
Return          Select
  
```

Adapting the heat curve

You can “break” the heat curve up or down every fifth outdoor degree. For example, you can make a hump in the curve at 0°C. The purpose of breaking the curve is to be able to influence the heat pump’s heat production at extra sensitive outdoor temperatures.

```

Temperature settings
Heat curve adjust.
(break)          1.3
Return          Select
  
```

Room sensor influence

The menu is only shown for heat pumps having a room sensor installed. You use the menu to set how much the room sensor should influence the heat curve. A higher value will have a greater effect. Please note that the room sensor only fine-tunes the heat curve. Consequently, it is important the basic setting of the heat curve’s slope and fine-tuning are correct.

```

Temperature settings
Setting of room
sensor infl.     1.11
Return          Select
  
```

Holiday mode

The menu is only shown for heat pumps having a room sensor installed. The holiday function gives you the possibility to choose a number of days when the room temperature will be lowered to 15°C (the temperature is not adjustable). When the days have passed the heat pump returns to the normal heating setting. Hot water production is not affected by the holiday function.

```

Temperature settings
Setting of holiday
function         1.12
Return          Select
  
```

Remote control

The menu is only shown for heat pumps having a room sensor installed. In addition, special remote control equipment is needed. This equipment is available as an accessory. You can switch between the remote control mode and normal mode using a telephone.

```

Temperature settings
Remote control
temperature     1.13
Return          Select
  
```

Summer disconnection

The function means the heat pump only produces hot water when the outdoor temperature rises above the set value.

```

Temperature settings
Setting of summer
disconnection   1.14
Return          Select
  
```

Set extra heat curve with mixing valve

If you have floor heating combined with radiators, you should set an extra heat curve with mixing valve. The mixing valve is a valve that lets water through in different amounts. It prevents the floor from becoming too hot and destroying the flooring. The menu is only displayed when there is an extra flow sensor, T4 (GT4), on the heat pump. You set the extra heat curve using two menus: Mix. valve incr/decr and Mix. valve fine-tune.

Increase or decrease the mixing valve

1. Press the Heat button until Access = CUSTOMER2 is displayed.
2. Press the Heat button.
3. Turn the menu dial clockwise until you reach the menu *Mix. valve incr/decr*.

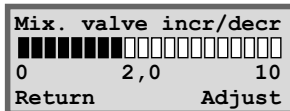

4. Press the Adjust button.
5. Turn the menu dial clockwise to choose a higher heat curve. Turn the menu dial anti-clockwise to choose a lower heat curve.
6. Save the new value by pressing the Save button.



Note

The initial position of the floor heating circuit is heat curve 2. The scale covers the range 0 to 10. Extra heat curve with mixing valve only works with an extra flow sensor T4 (GT4).

Fine-tune the mixing valve

1. Press the Heat button until Access = CUSTOMER2 is displayed.
2. Press the Heat button.
3. Turn the menu dial clockwise until you reach the menu *Mix. valve fine-tune*.

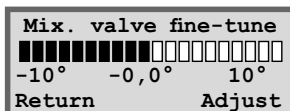

4. Press the Adjust button.
5. Turn the menu dial clockwise to set an upward, parallel offset on the curve. Turn the menu dial anti-clockwise to set a downward parallel offset on the curve.
6. Save the new value by pressing the Save button.



Note

The example describes how to fine-tune the extra heat curve. The scale covers the range -10°C to +10°C.

Hot water settings

Hot water peak

Recurring increase in the hot water temperature

The Interval for hot water peak is used to set the interval for a recurring increases in the hot water temperature. When you state the value seven days, for example, the temperature is increased by a further 5 degrees once a week.

```
Hot water setting.
Interval for
hot water peak  2.2
Return          Select
```

Timer control

Open the setting menus for timer control like this:

1. Press the Heat button until Access = CUSTOMER2 is displayed.
2. Press the Menu button.
3. Turn the menu dial clockwise until you access the menu *Timer control settings* (menu 4).
4. Press the Select button and scroll through the menus with control panel dial.

```
Main menu
Indoor temperature
settings          1
Return          Select
```

```
Main menu
Timer control
accord. to clock  4
Return          Select
```

Clock setting HP according to clock

The function *Clock setting HP according to clock* is for those who want the heat pump to produce different amounts of heat at different times of the day and on different days of the week. This allows you to make further energy savings.

Example:

You want to set the heat pump so that it maintains a 3°C lower radiator temperature on Mondays between 22.00 and 06.00.

1. Turn the dial clockwise until you access the menu *Clock setting HP accord. to clock* (menu 4.1).
2. Press the Select button.
3. Turn the menu dial clockwise to choose the day. Now press the Adjust button to select the weekday with the symbol ^. Turn the menu dial clockwise one step to activate the start day. The weekday now has a capital letter.
4. Press the right-hand arrow (->) until the cursor reaches the first two zeros (00).



Note

When you have time based tariffs with cheaper electricity for example during the night, any savings may be lost when the return to normal temperature occurs when the more expensive electricity price applies.

```
Clock setting
Clock setting HP
accord. to clock 4.1
Return          Select
```

```
Clock setting HP 1
mo  00.00-00.00
^
Return          Adjust
```

```
Clock setting HP 1
Mo  00.00-00.00
^
Return          ->
```

```
Clock setting HP 1
Mo  00.00-00.00
^^
Return          ->
```

5. Turn the menu dial until the value 22:00 is displayed.
6. Press the right-hand arrow twice (->) to move the cursor two steps to the right.
7. Turn the menu dial until the value 06.00 is displayed.
8. Press the right-hand arrow so it is replaced by the Save function.
9. Finish the setting by pressing the Save button.
10. Press the Return button.
11. Turn the menu dial clockwise until you reach the menu *Setting level Heat pump +/-* (menu 4.1.1).
12. Press the Select button and set the temperature to -3°C, which is to apply for the chosen time intervals.
Do not set a too large temperature reduction, max approx. 3 degrees for radiator systems and max approx. 1.5 degrees for floor heating systems is sufficient.
13. Finish by pressing the Save button.

```

Clock setting HP 1
Mo      22.00-06.00
Return  <-      ->

```

```

Clock setting HP 1
Mo      22.00-06.00
                ^^
Cancel  <-      Save

```

```

Clock setting HP 1
Setting level
heat pump +/-  4.1.1
Return        Select

```



Note

If you would like to make the setting for every day of the week, carry out the instruction shown in the example seven times, once for each weekday.

The temperature set under 4.1.1 applies to all active time intervals.

Clock setting DHW accord. to clock (menu 4.3)

The Clock setting of hot water according to clock works in exactly the same way as Clock setting of heat pump according to clock. You can choose to completely disable hot water heating to save energy. This is primarily effective when peak tariffs are charged. The procedure is the same as in the previous example. Use this to make your settings. The menu display where you make this setting is *Clock setting DHW accord. to clock* (menu 4.3).

```

Clock setting
Clock setting DHW
accord. to clock 4.3
Return          Select

```

Reading operating times on the heat pump and additional heat

Statistics concerning the heat pump and additional heat operations are stored in the control unit. For example, you can see how many hours they have been running. To view the operating times for the heat pump and additional heat:

1. Press the Heat button until Access = CUSTOMER2 is displayed.
2. Press the Menu button.

```

Main menu
Indoor temperature
settings      1
Return      Select

```

3. Turn the menu dial clockwise until you reach the menu *Op. times, readings on HP and add. heat* (menu 7).
4. Press the Select button and scroll through the menus with the menu dial.

```

Main menu
Op. time readings on
HP and add. heat 7
Return          Select

```

The number of hours the heat pump has been in operation

The menu shows the number of hours that the heat pump has been in operation since the day of installation.

```

Op. time readings
Heat pump in operat.
number of hours? 7.1
Return          Select

```

The heat pump's hot water mode and heating mode operations as a percentage

The menu show the heat pump's allocation between hot water mode and heating mode. The allocation is stated as a percentage.

```

Op. time readings
Distribution HP
DHW-Rad in %    7.2
Return          Select

```

The number of hours additional heat has been in operation

The menu shows the number of hours additional heat has been in operation since the day of installation.

```

Op. time readings
Add. heat in operat.
number of hours? 7.3
Return          Select

```

Additional heat's hot water mode and heating mode operations as a percentage

The menu shows the heat addition's allocation between hot water mode and heating mode. The allocation is stated as a percentage.

```

Op. time readings
Distribut. add. heat
DHW-Rad in %    7.4
Return          Select

```

Set the time and date

The heat pump has functions that are dependent on both the clock and date. Thus, it is important that these are correct. This is how you access the menu Clock, setting time and date:

1. Press the Heat button until Access = CUSTOMER2 is displayed.
2. Press the Menu button.

- Turn the menu dial clockwise until you reach the menu *Clock, setting time and date* (menu 10).
- Press the Select button and make your settings using the menu dial and menu buttons.

```

Main menu
Clock, setting
time and date    10
Return          Select

```

Alarms given by the heat pump

You can easily see any alarms given by the heat pump. The menu provides you with information about the alarm type and when it occurred. If there is an asterisk (*) in the menu window this means the alarm is still active, i.e. the cause of the alarm remains. This is how you access the Alarm logging of all alarms (menu 11):

- Press the Heat button until Access = CUSTOMER2 is displayed.
- Press the Menu button.
- Turn the menu dial clockwise until you reach the menu *Alarm logging of all alarms* (menu 11).
- Press the Select button and scroll using the menu dial between any alarms that may have previously occurred. Alarms are stored in chronological order. Read more about the heat pump's alarms under the heading *All alarms*.

```

Main menu    K2
Indoor temperature
settings      1
Return       Select

```

```

Main menu
Alarm logging
of all alarms  11
Return        Select

```

Return to the heat pump's factory settings

If you want to restore the factory settings on the heat pump you can easily reset all the settings you have made. This is how you access the Return to factory settings menu (menu 12):

- Press the Heat button until Access = CUSTOMER2 is displayed.
- Press the Menu button.
- Turn the menu dial clockwise until you reach the menu *Return to factory settings* (menu 12).
- Press the Select button.
- Return to the factory settings by pressing the Yes button. When you return to the factory settings all the adjustments made on customer levels 1 and 2 are reset such as temperature settings and time control settings.

```

Main menu    K2
Indoor temperature
settings      1
Return       Select

```

```

Main menu
Return to
factory settings 12
Return          Select

```

Care

Your heat pump requires a minimum of maintenance, however, we still recommend some servicing to get optimal performance from your heat pump. Check the following items a few times during the first year. You should then check them once or twice a year:

- Sight glass
- Expansion vessel
- Particle filter
- Protective anode (only models with a stainless steel hot water cylinder)



Warning

For reasons of safety the main power supply must be disconnected before working on the heat pump.

Only an accredited refrigeration company is permitted to work on the refrigerant circuit.

Unscrew the front cover

On certain models you will need to open the front cover to access some of the maintenance areas, e.g. the sight glass and particle filter. The front cover is secured at the top by two screws.

This is how you remove the front cover from the heat pump:

1. Unscrew the two screws on the top. See the picture.
2. Tilt the front cover towards you.
3. Lift the front cover up to release the lower edge.

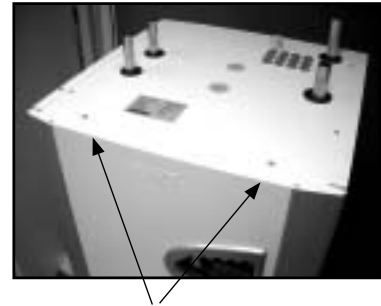

Remove the front cover by unscrewing the screws on the top.

Sight glass

Sometimes when the heat pump has started you can see the fluid in the refrigerant circuit bubble for a few minutes in the sight glass. This is completely normal. However, if it bubbles continuously you should contact your dealer.

Sight glass



If the sight glass shows green this means there is no moisture in the system. If it is yellow, there is moisture in the system. If this happens, contact your dealer.



Greenline HT Plus E

Expansion tank

A plastic expansion vessel is connected to the heat pump heat transfer circuit (cold side). The level in the vessel should not fall below the min-level 1/3. If the fluid level is too low, contact your dealer. After discussions with your dealer filling can take place as set out below:

The heat pump **must** be operational all the time while filling.

1. Remove the cover on the valve on top of tank. Now carefully open the valve (figure 1).
2. Check that the valve is fully open (figure 2).
3. Fill with anti-freeze or water (to 2/3) with the help of a clean watering can or the like (figure 3).
4. Close the valve and finish by screwing on the cover (figure 4).

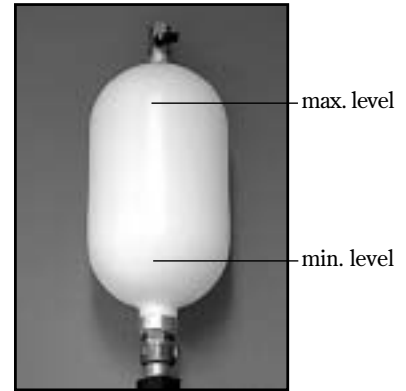

Figure 1



Figure 2



Figure 3

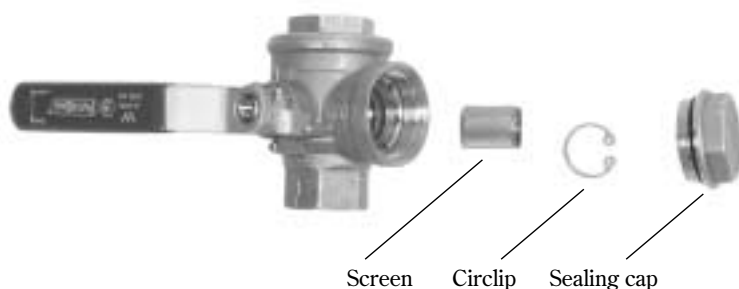

Figure 4

Particle filter

The task of a particle filter (is to ensure no particles or dirt enter the heat exchangers. Over time the filter can become clogged and will need cleaning. There are particle filters on both the hot and cold sides. To clean the particle filters:

1. Shut down the heat pump using the ON/OFF button.
2. Close the valve and unscrew the sealing cap.
3. Loosen the circlip holding the screen in the valve. Use the supplied circlip pliers.
4. Lift out the screen from the valve and wash clean with water.
5. Refit the screen, the circlip and sealing cap.
6. Open the valve and start the heat pump using the ON/OFF button.



Note

On the cold side the particle filter is located outside of the heat pump. It may be concealed by insulation material or a black box.

On Greenline HT E Plus the hot side's particle filter is fitted inside the heat pump. On Greenline HT Plus C it is located outside of the heat pump.

Particle filter



Greenline HT Plus E

Checking the protective anode

Only applies to heat pumps with integrated, stainless hot water cylinder.

A protective anode is located in the top of the cylinder with the task of preventing corrosion. The hot water cylinder must be filled with water in order for the anode to work.

A lamp, inside the front cover, indicates the anode status. If green, the protective anode is operating and working normally. Red can indicate a fault. When large amounts of hot water are used (e.g. with a bath) the lamp may show red for a short period without there being a fault. However, if the light is on for more than ten hours this indicates the anode is faulty and you should contact your dealer. If the fault occurs at the weekend, you can wait to the next working day before contacting your dealer.

Electronic anode

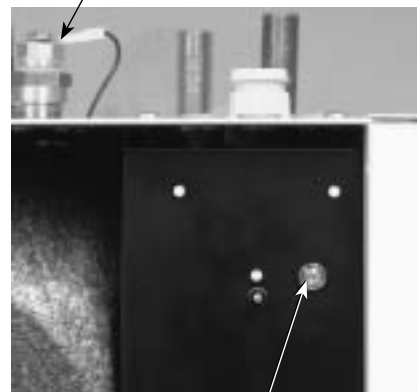

Lamp

Savings

The heat pump's task is to produce heating for the house as cost-effectively as possible. You can influence operating costs by your own settings for the heat pump. In addition, you can influence your energy savings by, for instance

- Lowering the indoor temperature.
- Opening thermostat valves completely.

Lowering the indoor temperature

The lower the indoor temperature the better the heating economy. So make sure you do not set the heat curve too high. Use your heating system in the best possible way by keeping the entire surface of radiators or floor coils warm.

1. Seal windows and doors, but not too tight.
2. When you air the room, do it quickly and with a cross draught.

Opening thermostat valves completely

The thermostat valves on radiators and floor coils can have a negative effect on the heating system by slowing the flow and, by doing so, the heat pump must compensate with a higher temperature. If thermostat valves are installed, they should be opened fully, except in bedrooms or other areas, where a lower temperature is required. In these rooms they can be somewhat closed.



Lower the heating.



Open the thermostat valves completely.

What to do if a fault occurs

The control unit has an advanced monitoring system that gives alarms if anything unforeseen happens in the heat pump. Most alarms are rectified by you the user and there is never any risk that you can damage anything in the heat pump when you reset an alarm.

If a room sensor is installed the lamp on this will come on when the heat pump gives an alarm.

Examples of an alarm:

Info button:

When you press the Info button and turn the menu dial, information is displayed as well as possible actions to rectify the alarm.

Ackn. button:

When you press the Ackn. Button, the alarm lamp on the control panel goes out and the heat pump starts again within 15 minutes if there is a heating requirement. If the fault has not been rectified the lamp will remain lit. Should several alarms have occurred on the heat pump, turn the menu dial clockwise to find out more information about each alarm.

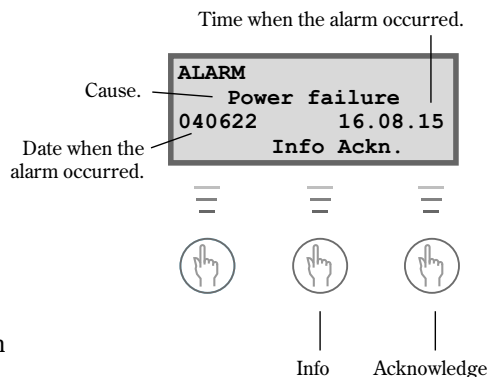

Dimmed menu display

Possible cause 1: Blown fuse in the house's fuse box/distribution box.

- Action:
1. Check the fuses in the house's fuse box.
 2. Replace the fuse if necessary. If miniature circuit-breakers have tripped these are reset by pushing up the toggle switch.
 3. The heat pump automatically returns to its operating mode 15 minutes after the fault has been rectified.

Possible cause 2: The heat pump's miniature circuit-breaker has tripped.

- Action:
1. Reset the heat pump's miniature circuit-breaker by pushing up the centre toggle switch.
 2. The heat pump automatically returns to its operating mode 15 minutes after the fault has been rectified.

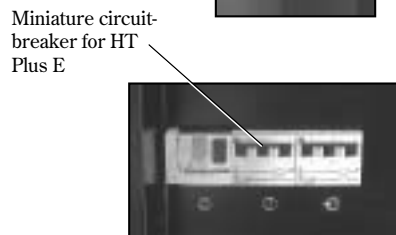
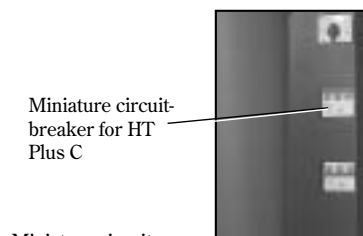

Note

For technical reasons the heat pump does not restart until 15 minutes after a stoppage.

Fuses and reset buttons on the heat pump

Greenline HT Plus C



Particle filter

Cleanable, with shutoff switch.

Fuse 1

Reset switch for motor cut-out compressor.

Fuse 2

Reset switch for the heat pump's miniature circuit-breaker.

Fuse 3

Reset switch for the electric cassette's miniature circuit-breaker.

Fuse 4

Reset button for the electric cassette overheat protection.
NOTE! The button must be pressed in firmly.

Sight glass

Greenline HT Plus E

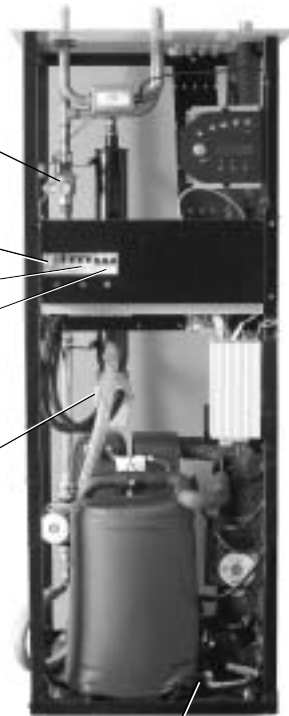

Sight glass

All Alarm

An alarm can sometimes occur temporarily due to various reasons. However, there is never a risk involved in resetting an alarm. All the alarms that can appear in the menu display are described on the following pages. The descriptions give you an idea about the nature of the alarm and what you can do to rectify it. The text often refers to different fuses and reset buttons on the heat pump. These are shown in the figures above.

List of all alarms:

- Motor cut-out compressor
- Motor cut-out HTF pump
- Compressor temperature
- Low pressure switch
- High pressure switch
- Electric cassette
- Power failure
- Phase incorrect
- High return to the heat pump
- Heat tran. f out max
- High HTF delta
- Sensor fault
- Heat transfer fluid in under limit and heat transfer fluid out under limit

Motor cut-out compressor (MB1)

Possible cause 1: Intermittent fault or overload on the power supply.

- Action:
1. Press the Ackn. button.
The alarm indication goes out even if the fault has not been rectified.
 2. Press in the motor cut-out button on the heat pump. (Fuse 1).
 3. Wait for the heat pump to start.

Possible cause 2: Current level (A) on the motor cut-out is set too low.

The current drawn by the compressor varies during summer/winter operations.

- Action:
1. Contact your dealer.

Possible cause 3: Contactor or cut-out faulty, or loose electrical connections to the compressor.

- Action:
1. Contact your dealer.

Possible cause 4: Compressor error.

- Action:
1. Contact your dealer.

The menu display shows:

ALARM (MB1)	
Compr. circ. switch	
040622	16.08.15
Info Ackn.	



Note

The reset switch for the compressor can be found under heading *Fuses and resetting buttons on the heat pump*.

Motor cut-out HTF pump (MB2)

(Not models C11:, E11, E14 and E17)

Possible cause 1: The HTF pump is blocked due to contamination.

- Action:
1. Press the Ackn. button.
 2. Loosen the venting screw and remove the dirt.
 3. Help to start the pump with a screwdriver.
The alarm indication goes out even if the fault has not been rectified.

Possible cause 2: Faulty electric motor on HTF pump.

- Action:
1. Contact your dealer.

Possible cause 3: Temporary error.

- Action:
1. Contact your dealer should repeated faults occur.

The menu display shows:

ALARM (MB2)	
HTF c-pump switch	
040622	16.08.15
Info Ackn.	



Note

The alarm indication goes out when acknowledging the alarm even if the fault has not been rectified.

Compressor temperature T6 (GT6)

The menu display shows:

ALARM (GT6)	
Compr. superheat	
040622	16.08.15
	Info Ackn.

Possible cause 1: The compressor's working temperature is too high

Action:

1. Press the Ackn. button.
2. Contact your dealer at repeated alarms.

Possible cause 2: Intermittent temperature rise due to abnormal operating conditions

Action:

1. Press the Ackn. button.
2. Wait and see.

Low pressure switch (LP)

The menu display shows:

ALARM (LP)	
Low pressure switch	
040622	16.08.15
	Info Ackn.

Possible cause 1: Air in the heat transfer system.

Action:

1. Press the Ackn. button.
2. Check the expansion vessel.
3. Fill with fluid if necessary.
4. Listen for air in the system. If air is heard constantly, contact your dealer.

Possible cause 2: The particle filter on the cold side is clogged.

Action:

1. Check the particle filter.
2. Clean the particle filter if necessary.
3. Press the Ackn. button.

Possible cause 3: Lack of refrigerant in the heat transfer circuit.

Action:

1. Press the Ackn. button.
2. Wait for the heat pump to start.
3. Check whether it bubbles continuously in the sight glass.
4. If it bubbles continuously, contact your dealer.

Possible cause 4: The HTF pump has stopped or is set at too low a speed.

Action:

1. Press the Ackn. button.
2. Check that the pump has not stopped or is set at the wrong speed.

Possible cause 5: Ice formation in the heat exchanger due to a lack of anti-freeze in the heat transfer circuit.

Action:

1. Contact your dealer.

Possible cause 6: Faulty expansion valve (the alarm appears in time periods of 3-4 weeks.)

Action:

1. Contact your dealer.



Note

LP in the menu display stands for low pressure switch.

High pressure switch (HP)

Possible cause 1: Air in the heating system.

- Action:
1. Press the Ackn. button.
 2. Check whether there is air in the radiators.
 3. Fill the heating system and vent if necessary.

Possible cause 2: Not enough flow over the heat pump.

- Action:
1. Press the Ackn. button.
 2. Check that the heat carrier pump has not stopped.
 3. Check that all the valves are open. The thermostat valves in heating systems should be fully open and in floor heating systems at least half of the coils should be fully open.
 4. Possibly increase the speed of the heat carrier pump.

Possible cause 3: The particle filter on the hot side is clogged.

- Action:
1. Press the Ackn. button.
 2. Check the filter.
 3. Clean the filter if necessary.

ALARM (HP)	
High pressure switch	
040622	16.08.15
	Info Ackn.



Note

HP in the menu display stands for high pressure switch.



Note

Increase the speed of the heat carrier pump:

Use a screwdriver or a coin to increase the speed of the heat carrier pump. Turn one step anti-clockwise.



Electric cassette (EK)

Possible cause 1: The electric cassette's miniature circuit-breaker has tripped.

- Action:
1. Press the Ackn. button.
 2. Reset the miniature circuit breaker button on the heat pump (circuit breaker 3) by pushing up the toggle switch.
 3. Contact your dealer if the miniature circuit breaker trips again.

Possible cause 2: The electric cassette's overheat protection has tripped.

- Action:
1. Press the Ackn. button.
 2. Reset the overheat protector (circuit breaker 4) by pressing in the button on the electric cassette's protective casing. The circuit breaker is reset when you hear a clicking sound.
 3. Check that the particle filter on the hot side is clean.

ALARM (EK)	
Electric cassette	
040622	16.08.15
	Info Ackn.



Note

The miniature circuit breaker button for the electric cassette can be found under the heading Fuses and reset buttons on the heat pump for the heat pump.

The most frequent cause for the overheat protection tripping is a poor flow over the heat pump, which can be due to air in the heat pump or that the particle filter is clogged.

Power failure

The heat pump maintains all its settings in case of a power failure. When the power returns the heat pump automatically starts up according to the previous settings.

ALARM	
Power failure	
040622	16.08.15
	Info Ackn.

Possible cause: One or two phases to the heat pump are down.

- Action:
1. Check that the fuses in the house's distribution box have not blown.
 2. Change the fuse if necessary. If you have miniature circuit-breakers and these have tripped you reset them by pushing up the toggle switch.
 3. The heat pump automatically returns to the operating mode once the fault has been rectified.

3-phase incorrect

Possible cause 1: One or two phases to the heat pump are down.

- Action:
1. Check that the fuses in the house's distribution box have not blown.
 2. Replace the fuse if necessary. If you have miniature circuit-breakers and these have tripped you reset them by pushing up the toggle switch.
 3. The heat pump automatically returns to the operating mode once the fault has been rectified.

ALARM	
Phase incorrect	
040622	16.08.15
	Info Ackn.

Possible cause 2: Phase sequence to the heat pump is incorrect. (The alarm may only be rectified by an electrician.)

- Action:
1. Press the Ackn. button.
 2. Switch the phase sequence on the incoming supply.
The heat pump starts automatically once the phase sequence has been switched.



Note

If the power does not return on all phases at the same time during external electrical work, there is a risk that the Rego control unit gives a false alarm for a phase sequence error.

High heat distribution system delta T8/T9 (GT8/GT9)

The heat pump gives an alarm when the temperature difference between the sensors T8 (GT8) and T9 (GT9) is too high.

Possible cause 1: Not enough flow over the heat pump.

- Action:
1. Check that the heat carrier pump has not jammed.
 2. Check that all the valves are open. The thermostat valves in heating systems should be fully open and in floor heating systems at least half of the coils should be fully open.

ALARM	GT8/GT9
High HTF delta	
040622	16.08.15
	Info Ackn.

Possible cause 2: The particle filter on the hot side is clogged.

- Action:
1. Clean the particle filter.

High return to the heat pump T9 (GT9)

There is a sensor T9 (GT9) in the heat pump, which for reasons of safety, stops the compressor if the temperature of the return water from the radiators becomes too high. The limit lies at approximately 58°C.

ALARM	(GT9)
High return HP	
040622	16.08.15
	Info Ackn.

Possible cause 1: The heating setting is too high.

Action: 1. Lower the heating setting (Temp. incr. / decr.).

Possible cause 2: The valves on the radiators or floor heating system are closed.

Action: 1. Open all valves.
2. Press the Ackn. button.

Possible cause 3: The hot water temperature is set too high.

Action: 1. An alarm is given in hot water mode.
Contact the installer to adjust the hot water temperature.

Possible cause 4: The flow across the heat pump is greater than the flow in the heating system.

(Only applies if a bypass is fitted.)

Action: 1. Reduce the speed of the heat carrier pump or increase the speed of the main pump in the heating system.
2. Contact your dealer.



Note

The heat pump starts automatically when the temperature drops.

Lower the speed of the heat carrier pump:

Use a screwdriver or a coin to lower the speed of the heat carrier pump. Turn one step clockwise. The lowest speed should be avoided.



Heat transfer fluid out max T8 (GT8)

There is a sensor T8 (GT8) in the heat pump, which for reasons of safety, stops the compressor if the temperature of the water going out to the radiators becomes too high.

ALARM	(GT8)
Heat tran. f out max	
040622	16.08.15
	Info Ackn.

Possible cause 1: Not enough flow over the heat pump.

Action: 1. Check that the heat carrier pump has not jammed.
2. Check that all the valves are open. The thermostat valves in heating systems should be fully open and in floor heating systems at least half of the coils should be fully open.

Possible cause 2: The particle filter on the hot side is clogged.

Action: 1. Clean the particle filter.



Note

The heat pump starts automatically when the alarm is reset and the water temperature has dropped to its normal value.

Sensor fault

All sensors connected to the heat pump can give an alarm when defective. In the example to the right it is sensor T1 (GT1), Return radiator, which has given an alarm. All sensors give alarms in the same way. Read more about the sensors under heading All the temperature sensor menus.

ALARM (GT1)	
Sensor return rad.	
040622	16.08.15
Info Ackn.	

Possible cause 1: Temporary error.

Action: 1. Wait and see.

Possible cause 2: Short circuit or broken sensor cable.

Action: 1. If you have an ohmmeter you can disconnect the sensor and check the cable's resistance. Compare with the sensor table in the section *Technical information*. Otherwise contact your dealer.

Possible cause 3: Defective sensor or incorrect connection.

Action: 1. Contact your dealer.



Note

Switch off the power before checking the resistance of the cable.

HTF in below limit T10 (GT10) and HTF out under limit T11 (GT11)

Possible cause 1: Temporary low heat transfer fluid temperature.

Action: 1. Wait and see.
2. If the alarm returns, contact your dealer.

ALARM (GT10)	
HTF (coll) in	
040622	16.08.15
Info Ackn.	

Possible cause 2: Too low flow on the cold side.

Action: 1. Check the particle filter.
2. Clear the filter if it is clogged.

Possible cause 3: The minimum heat transfer fluid temperature has been set too low.

Action: 1. Wait and see.
2. If the alarm returns, contact your dealer.

ALARM (GT11)	
HTF (coll) out	
040622	16.08.15
Info Ackn.	

In a groundwater system the cause may also be:

Possible cause 4: Clogged filter in the groundwater circuit.

Action: 1. Clean the filter.

Possible cause 5: The motor cut-out or a fuse on the pump in the groundwater system has tripped.

Action: 1. Reset the motor cut-out or fuse.

Possible cause 6: Faulty pump in the groundwater circuit.

Action: 1. Contact your dealer.

For the Installer

Installation of the heat pump should be performed by a qualified installer. The “Installer” chapter includes a section suggesting how the heat pump installer should install and commission the heat pump. The installation consists of a plumbing section and an electrical section. These provide technical data such as measurements, wiring diagrams and installer menus. We hope that you read through this manual carefully and that you respect all notes and warning texts.

Contents:

- Important information to the installer
- Checklist
- What the shipment includes
- The heat pump and collector hose in general
- Measurements and electrical connections
- Preparations before connection
- Connecting the heat pump to the heating system
- Connecting the heat pump to the power supply
- External connections to the heat pump
- Commissioning the heat pump
- Technical information



Note

It is important that as the installer you also read through the For the User section of the manual. Here you will find the information necessary to get a comprehensive understanding of the heat pump.

Important information to the installer

This manual provides you with all the information necessary to install the heat pump Greenline HT Plus. The manual is divided into several sections. The order of these is based on the recommended installation sequence. Use the supplied checklist during installation.

Before installation remember:

- Installation of the heat pump should be performed by a qualified installer.
- If the heat pump needs to be taken downstairs it may be temporarily tilted with the compressor downwards. However, never lay the heat pump down or transport it horizontally.
- Before the heat pump is commissioned, the heat transfer systems including the heat pump must be filled and vented.
- Check that pipe connections on the cold and hot sides are intact and have not shaken loose during transport.
- The HTF pump should be running when the heat transfer system is vented.
- The control unit measures the phase sequence and gives an alarm if the power supply has been connected incorrectly.
- Wiring should be kept as short as possible to protect the system from downtime, for example during a thunderstorm.
- The heat pump installation must follow applicable regulations. More information is available at www.boverket.se.
- Energy drilling and installation of the rock collector should be carried out in accordance with "Normbrunn 97" (Standard for Energy wells) or the like.



Warning

For reasons of safety the main power supply must be disconnected before working on the heat pump.

Checklist

Each heat pump installation is unique. However, the following checklist will give you a general description of how the installation should be carried out.

1. Place the heat pump on a flat surface. Adjust the height using the rubber feet.
2. Check that the bore hole for the collector hose has been bored according to applicable regulations (responsibility of the drilling company).
3. Fit the incoming and outgoing pipes for the heating and heat transfer fluid circuits as well as the expansion vessel.
4. Fit the particle filters and valves.
5. Make the connections for any external additional heat.
6. Connect the pump to the heating system (plumbing). Follow the instructions for the pump in question.
7. Install the outdoor sensor and a room sensor if used.
8. Fill and vent the heating and heat transfer systems before commissioning.
9. Connect the heat pump to the electrical system. Use the wiring diagram applicable for the right heat pump in question.
10. Connect the external switch as well as additional heat if used, and an earth-fault breaker.
11. Connect a general alarm, external controls and load monitor.
12. Commission the heat pump by making all the necessary settings on the control panel.
13. Check the heat pump after commissioning. Top up the heat transfer fluid if required.

What the shipment includes

The following components are included in the delivery of the Greenline HT Plus heat pump:



Rubber feet
Quantity: 4
Art. no: 381 007



Particle filter with screen
No. of Greenline HT Plus C:
1, art. no: 142 020 + 1, art. no: 142 025

No. of Greenline HT Plus E:
1, art. no: 142 025



Expansion tank
Quantity: 1
Art. no: 385 705



Circlip pliers
Quantity: 1
Art. no: 142 021



Ball valve
Quantity: 1
Art. no: 153 012



Drain plug
Quantity: 1
Art. no: 051 701 70



Safety valve
Quantity: 1
Art. no: 154 004



Manual
Quantity: 1
Art. no: 290 410



Outdoor sensor T2 (GT2) with cable
Quantity: 1
Art. no: 240 690



Warranty and insurance certificate
Quantity: 1
Art. no: 290 432



Return sensor T1 (GT1)
Quantity: 1
Cable: 4 m
Art. no: 240 693

Dimensions and connections

The following illustrations show the dimensions of the heat pump and plumbing connections. All measurements are stated in millimetres.

HT Plus C



1800

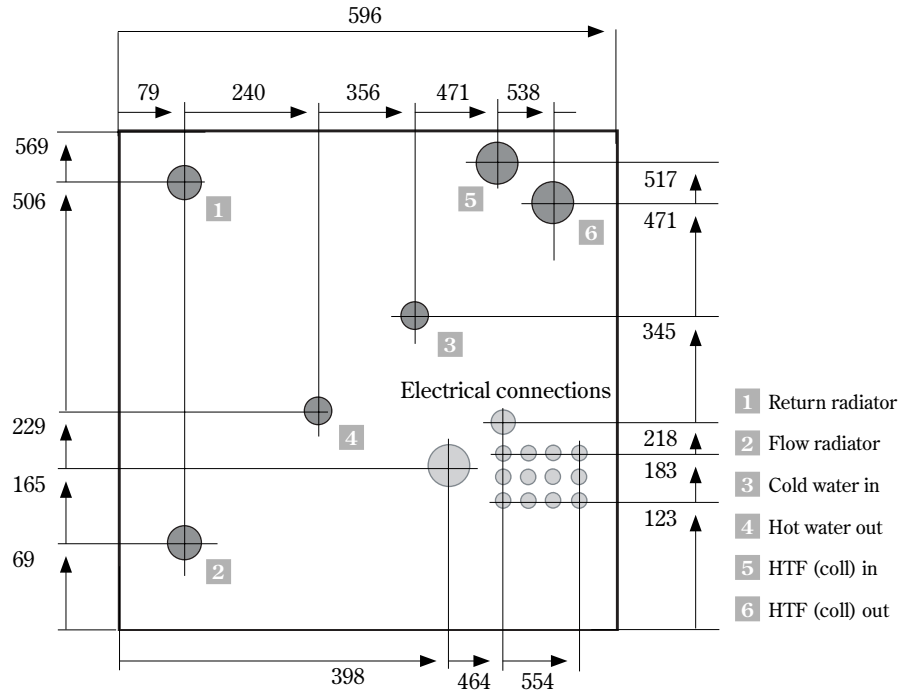

HT Plus E



1520

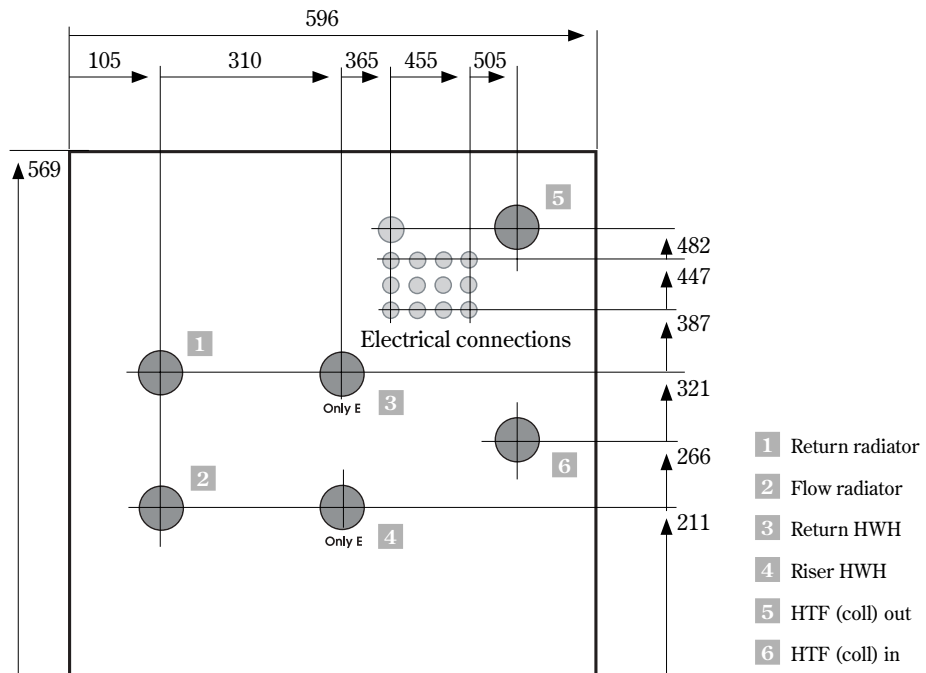

FOR THE INSTALLER

The heat pump and collector hose in general

Transporting the heat pump

The heat pump should always be transported and stored in an upright position. Otherwise the suspension fittings inside the compressor can be damaged. If the heat pump must be tilted during entry to the installation site, this should be done for as short a time as possible. The outer cover plates should be removed to avoid damage, if the heat pump is moved without using the supplied pallet.

The heat pump must not be stored at temperatures below -10°C.

Positioning the heat pump

It is important that the heat pump stands on a flat surface as it contains sensitive parts. Adjust the rubber feet so the heat pump does not lean.

The temperature surrounding the heat pump must be between 0°C and 35°C.

The installer should take sound propagation into consideration when positioning the heat pump.

Make sure there is a floor drain in the room where the heat pump is installed. The floor drain ensures any water is easily transported away if leakage should occur.

Maximum working temperatures

The heat pump can work at a maximum return water temperature of approximately 57°C. If the temperature rises above this value the heat pump will stop for reasons of safety.

The maximum outgoing temperature to the heating system is around 65°C. However, even higher temperature can be attained with the help of the immersion heater.

Fit the particle filter

The task of the particle filter is to filter out dirt before it can enter the heat pump. Accordingly, the supplied particle filters should **always** be fitted on the incoming pipes on both the hot and cold sides. The filters should be fitted as close to the heat pump as possible and placed horizontally.

Two particle filters are supplied with Greenline HT Plus C. These are to be fitted on the outside of the heat pump. On Greenline HT Plus E the particle filter for the hot side is already fitted inside the heat pump. The supplied filter is to be fitted on the cold side, outside of the heat pump.

Collector hose

The task of the collector hose is to convey the heat transfer fluid through the ground or lake to fetch a few degrees of heat. The hose consists of a thin-walled plastic hose of the type PEM 40 x 2.4 PN 6.3.

It is important when the collector hose is placed in the ground that air pockets are avoided.

Installation and refilling around the collector hose

Installation and filling the soil around the collector hose should follow applicable material and working descriptions and regulations. See www.byggjtjanst.se for more information.

It is important that the filling material does not contain stones or other sharp objects that can damage the collector hose. We also recommend that the hose is pressure tested before starting to refill. If the hose should leak it is easier to fix the problem.

When cutting the collector hose it is important that no dirt or gravel enters the system. Dirt and gravel can cause a blockage in the heat pump.

Minimum permitted bending diameter

Minimum permitted bending diameter is 1 metre. If sharper bends are required an elbow connector must be used. If the collector hose is damaged by too sharp a bend, you can repair the damage using a straight coupling.

Maximum length of the collector hose

The maximum length of the collector hose is based on the heat carrier pump's pressure setting. We recommend a heat transfer fluid consisting of max 29 per cent ethanol by volume and water. Ethanol has good environmental and technical properties even at low temperatures and should therefore be used instead of other heat transfer fluids.

Heat pump model	Maximum hose length in one circuit	Maximum hose length per hose in two circuits
Greenline HT Plus C6/E6	600 metres	-
Greenline HT Plus C7/E7	500 metres	1000 metres
Greenline HT Plus C9/E9	400 metres	800 metres
Greenline HT Plus C11/E11	400 metres	800 metres
Greenline HT Plus E14	-	800 metres
Greenline HT Plus E17	-	800 metres



Note

The depth and length of the collector hose are described in detail in the configuration program VPW2000.



Note

The maximum collector hose lengths for heat pump models are provided in the table.

In situations where the length of the collector hose needs to exceed the permitted value, you can connect the hoses in parallel. Note that for parallel connecting the maximum length per hose is specified. As an example the table shows that for E11 the maximum hose length is 400 metres. For two hoses connected in parallel the maximum length is 800 metres per hose, i.e. in total 1600 metres with a parallel connection.

Outline drawings for the collector hose in the ground and through a wall

The drawings below show how to run the collector hose in the ground and through a wall. The soil filling around the hose must not contain stones. If the hose is ploughed down, you must use equipment that guarantees the hose is laid at the right depth.

Collector in the ground

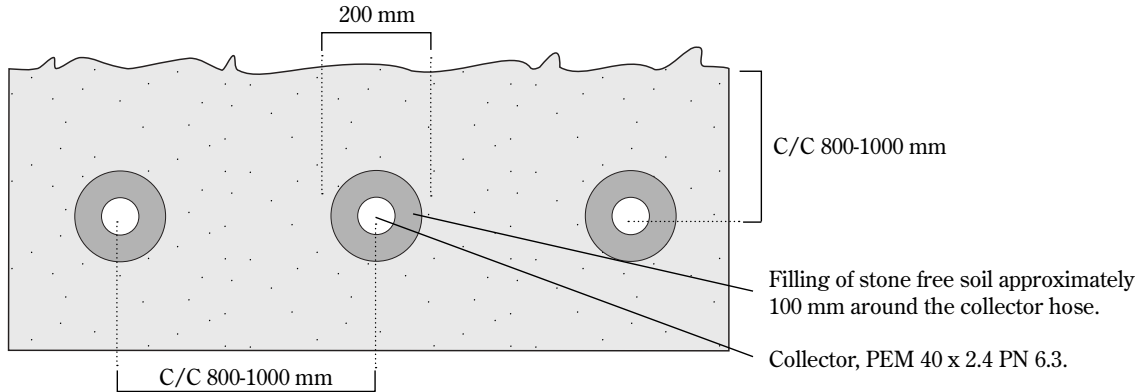

Example of the collector through the wall (from the side)

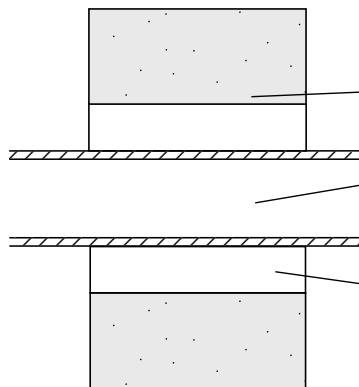

Example of the collector through the wall (cross section)

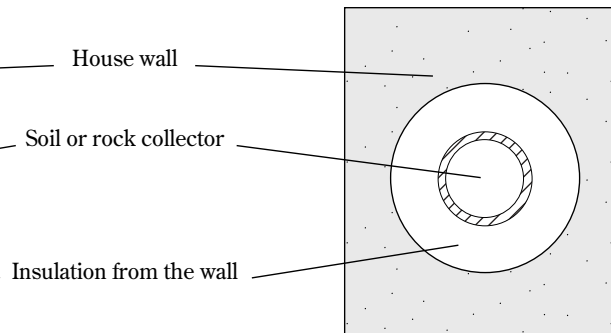

Connecting the collector hose to the heat pump

It is important that the collector hose has been pressure tested before it is connected to the heat pump. Pressure testing is carried out by the boring company or excavating company and determines whether the hose is in one piece and works as it should. When laying the ground heat hose the hose is usually pressurised during the laying process.

Another leakage test should be performed on the collector hose before commissioning the heat pump.



Note

Non-flammable pipe material must be used when routing the pipes indoors. When plastic hose is used indoors this must be protected by 40 mm fire resistant, mineral wool sheet, EI30.

You can connect the collector hose to the heat pump with one or more circuits. In a multi-circuit solution, the collector hoses are connected in parallel as illustrated below. The parallel hoses are connected to two distributors. Each coil should have a shutoff valve and a control valve. The control valve is adjusted so that the flow rate is the same in the coils.

After the distributor and the valves, the coils are connected to a collecting pipe. A filling unit, particle filter and an expansion vessel are connected to the collecting pipe. A safety valve is connected to the outgoing pipe. The safety valve leads off any overpressure.

One circuit at a time is filled with heat transfer fluid. Keep the valves closed in the other loops during the process. Read more about filling under the headings *Connecting the heat pump to the heating system* / *Filling water in the heating system* and *Filling the heat transfer fluid in the collector hose*.

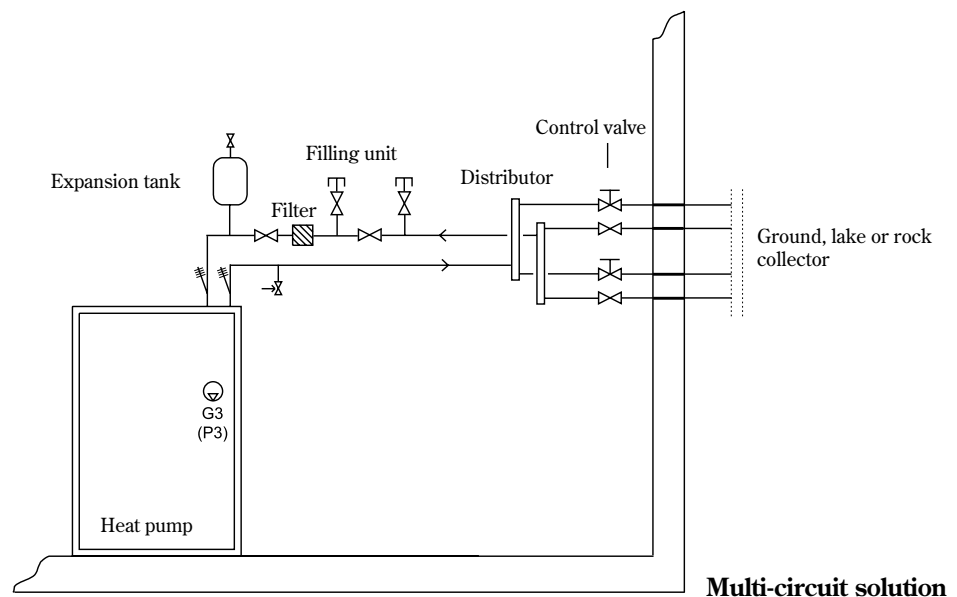
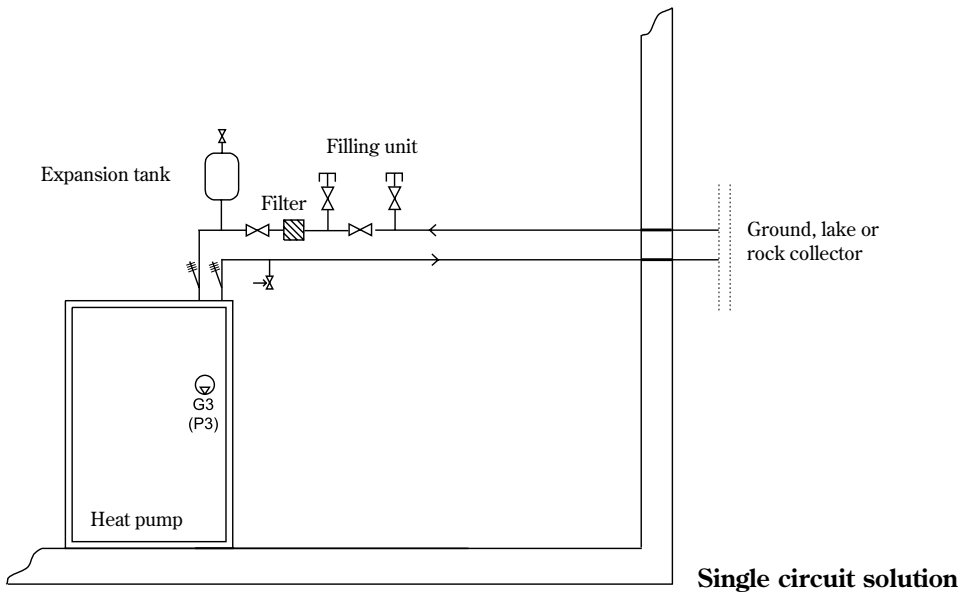

FOR THE INSTALLER

Preparations before connection

In some situations the heat pump may need extra preparations before it is commissioned. Such preparations may be:

- Moving the heat transfer fluid pipe for side entry
- Supplement the heat pump with a ground water system

Moving the heat transfer fluid pipe for side entry

When the heat pump is supplied the heat transfer fluid side is assembled for a top installation. This means the pipes for heat transfer fluid in and heat transfer fluid out run through the top of the heat pump.

If the heat pump is positioned in the house so it is difficult to install the heat transfer fluid pipes on the heat pump from above, they can be fitted from the side (side installation). Both the right- and left-hand sides are prepared for side installation. The following pages describe side installation.

Side installation should be done before the heat pump is positioned in its final installation location.

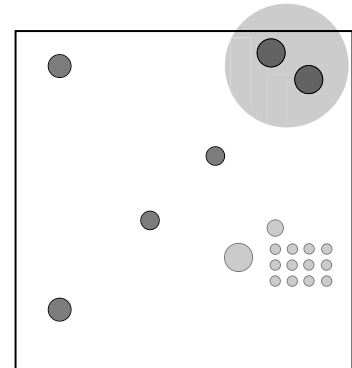

The heat transfer fluid pipes are fitted for top installation when the heat pump is delivered.

Side installation on the right-hand side

Proceed as follows to switch the heat transfer fluid pipes from top installation to side installation on the right:

1. Remove the blanking washers (figure 1).
2. Dismantle the sensor and both heat transfer fluid pipes. The pipes run to the top of the top plate. Heat transfer fluid in is connected by a connector on top of the HTF pump. Heat transfer fluid out is connected to the bottom of the heat exchanger (figure 2).

Note: The sensor fitted to heat transfer fluid out must be dismantled first (figure 2).

3. Remove the Armaflex insulation from the heat transfer fluid pipes so they are completely clean (figure 3).
4. Cut the heat transfer fluid pipes so they are suitable for right-hand side installation (figures 4 and 5). Follow the measurements given in figures 6 and 7.
5. Solder on a solder elbow and a straight piece of copper tube. You can use the piece left over from cutting the heat transfer fluid out pipe as the straight piece.

Note: Do not use compression ring couplings to secure the solder elbow on the copper pipe. Compression ring couplings require more space and space is limited in the heat pump.

6. Refit the heat transfer fluid pipes on the heat pump. See the result in figure 8.
7. Assemble the sensor on the heat transfer fluid in pipe. Use aluminium tape and cable ties.
8. Slide on Armaflex insulation on both pipes and secure using Armaflex tape. Make sure you cover both pipes well, otherwise there is a risk of condensation.



Figure 1

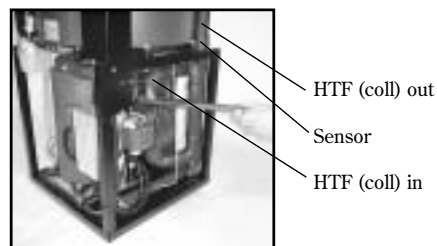

Figure 2



Figure 3



Figure 4 Heat transfer fluid in



Figure 5 Heat transfer fluid out

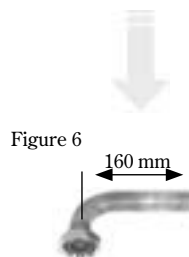

Figure 6

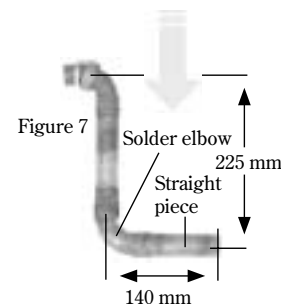

Figure 7



Figure 8

Side installation on the left-hand side

Proceed as follows to switch the heat transfer fluid pipes from top installation to side installation on the left:

1. Switch the heat pump's right- and left-hand side covers.
2. Remove the blanking washers (figure 1).
3. Dismantle the sensor and both heat transfer fluid pipes. The pipes run to the top of the top plate. Heat transfer fluid in is connected by a connector on top of the HTF pump. Heat transfer fluid out is connected to the bottom of the heat exchanger (figure 2).

Note: The sensor fitted to heat transfer fluid out must be dismantled first (figure 2).

4. Remove the Armaflex insulation from the heat transfer fluid pipes so they are completely clean (figure 3).
5. Cut the heat transfer fluid in as in figure 4. Follow the measurements in figure 6. Solder on a solder joint and piece of straight copper tube. Use the material left over from cutting.
6. Cut the heat transfer fluid out as in figure 5. Follow the measurements in figure 7. Solder on a solder elbow and a piece of straight copper tube. Use the material left over from cutting.

Note: Do not use compression ring couplings to secure the solder elbow on the copper pipe. Compression ring couplings require more space and space is limited in the heat pump.

7. Refit the heat transfer fluid pipes on the heat pump. See the result in figures 8 and 9.
8. Assemble the sensor on the heat transfer fluid in pipe. Use aluminium tape and cable ties.
9. Slide on Armaflex insulation on both pipes and secure using Armaflex tape. Make sure you cover both pipes well, otherwise there is a risk of condensation.



Figure 1

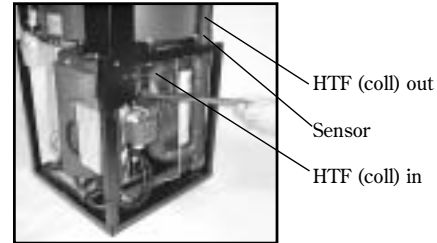

Figure 2



Figure 3



Figure 4 Heat transfer fluid in



Figure 5 Heat transfer fluid out

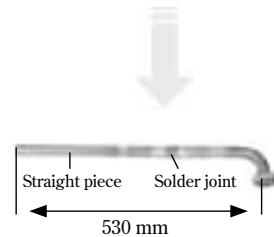

Figure 6

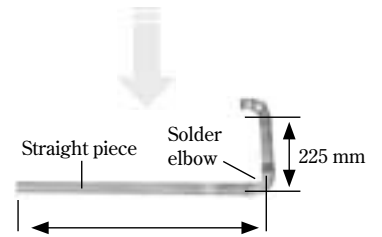

Figure 7



Figure 8 View from the left



Figure 9 View from the right

Supplementing the heat pump with a ground water system

If the heat pump is installed for groundwater instead of rock, soil or lake, it must be supplemented with an intermediate heat exchanger. The intermediate heat exchanger protects the heat pump from contamination, clogging and freezing.

A groundwater pump with non-return valve is installed at the bottom of the bore hole. The pump is used to pump the groundwater from the water source to the intermediate heat exchanger. Heat is transferred to the heat transfer fluid in the intermediate heat exchanger. The water is then pumped to a recharge well. The intermediate exchanger is installed in the boiler room or the like.

The circuit to the heat pump is installed in the same way as described earlier i.e. with filling unit, expansion vessel and safety valve. The circuit should also be protected against freezing down to -15°C .



Note

The intermediate heat exchange should be connected against the flow. In addition, the pipe from the groundwater well is connected to the bottom of the intermediate heat exchanger so that the flow goes upwards.

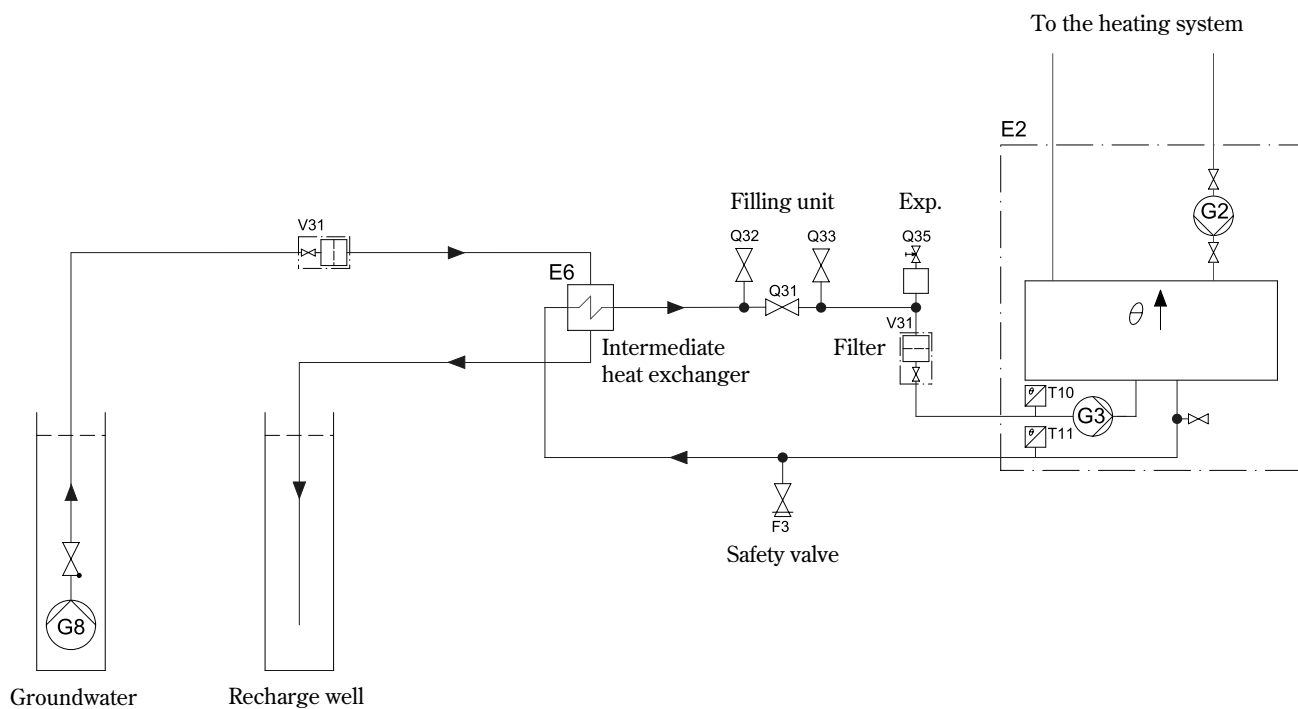

Ground water system: Electrical connection

1. Connect the ground water pump to the mains (3 x 400 V) via a motor cut-out and a contactor. The control to the contactor (CK3) uses 230 V, which is taken from the terminals L and N (P3) in the heat pump.
2. Connect the auxiliary contact for the motor cut-out MB3 in series with the alarm input MB2. This method starts and stops the groundwater pump with the heat pump's HTF pump. If the motor cut-out MB3 trips, the heat pump stops and the alarm for the HTF pump is displayed on the menu display.

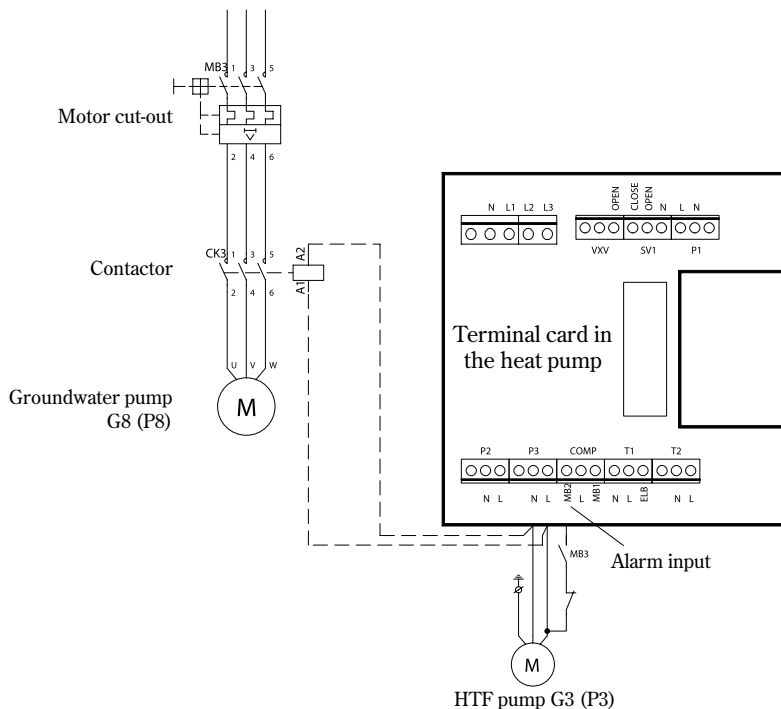

Warning

If a single phase pump is used, it should **always** be connected with a contactor.
It must never be connected to the P3 output on the heat pump as this can damage the control unit.

FOR THE INSTALLER



Note

There is a built-in motor cut-out in the pump on the 11-17 kW models. Models 6-9 kW have a strap fitted between L and MB2 on the terminal card.

Connecting the heat pump to the heating system

It is important that all previously mentioned preparations have been carried out before the heat pump is connected to the heating system. Also ensure the pipe system has been well flushed before it is connected to the heat pump. Flushing protects the heat pump from contamination.

The heating system must be diffusion-proof. Oxygen must not enter the system. The heat pump is only intended to work in oxygen free systems with so-called "dead water". When oxygen enters the system this causes corrosion in the heat pump and clogging of the filter on the heat transfer side. An intermediate heat exchanger is necessary in systems with oxygen penetration/diffusion to protect the heat pump.



Note

Only qualified installers may carry out the installation. The installer should observe applicable regulations and our recommendations.

Connecting to the heating system without a bypass:

The heat pump can be connected to the heating system without a bypass, as the circulation in the heat pump and the heating system is managed by the integrated pump G2 (P2). This also means the main pump G1 (P1) is omitted. An absolute prerequisite for the connection is that a minimum flow of at least 70% of the nominal flow (see the table below) can be maintained throughout the year. The thermostat valves in the heating system should be fully open and in a floor heating system, it is necessary for at least half of the coils to be fully open.

The control unit gives an alarm when the temperature increase exceeds 13°C in the heating system. If the heating system is designed so that a minimum flow cannot be guaranteed, the heat pump should be connected using a bypass and an external main pump G1 (P1).

Hot water function:

Hot water charging is started by the hot water sensor T3 (GT3), and is stopped by the return sensor T9 (GT9).

Circulation pump

The circulation pump G2 (P2) is a Wilo Star 25/6-130 in heat pumps from 6 to 11 kW.

The circulation pump G2 (P2) is a Wilo TOP-S 25/7.5 EM in heat pumps from 14 to 17 kW.

The pump curves apply for water +20°C.

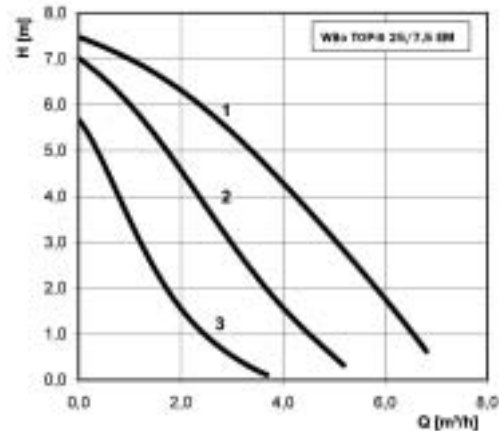
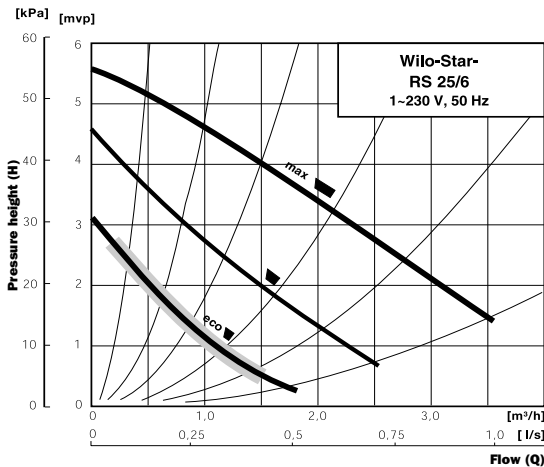

Maximum external pressure drop in the heating system:

The maximum external pressure drop and the minimum flow that the integrated circulation pump can handle is presented in the table. If the minimum flow cannot be guaranteed a bypass and an external main pump G1 (P1) should be installed.

Heat pump	Nominal flow	Minimum flow	Max external pressure drop
C6/E6	0.20 l/s	0.14 l/s	36.0 kPa
C7/E7	0.25 l/s	0.18 l/s	36.0 kPa
C9/E9	0.31 l/s	0.22 l/s	34.0 kPa
C11/E11	0.37 l/s	0.26 l/s	33.0 kPa
E14	0.50 l/s	0.35 l/s	54.0 kPa
E17	0.57 l/s	0.40 l/s	51.0 kPa

Connect heat pump C to the heating system

Application: The principle is based on floating condensing in the heat pump (curve control) and additional heat from the electric cassette. The built-in control unit controls the heat pump using the outdoor sensor T2 (GT2) and the return sensor T1 (GT1) according to the outdoor compensated control curve. When the heat pump is unable to meet the heating requirements, the electric cassette starts automatically and together with the heat pump provides the required temperature. The heating of hot water is given priority over the heating of the heating water. Hot water heating is controlled by the sensor T3 (GT3), which is located in the hot water cylinder. When the water in the cylinder is heated, a three-way valve temporarily disconnects heating radiator mode. When the water in the cylinder reaches the required temperature, heat is once more supplied to the heating system.

The control unit can also control a second curve together with a mixing valve. The mixing valve curve must be set lower than the heat curve for the rest of the heating system. This extra function is used, for example, in a floor heating system that requires a lower temperature.

Connecting the sensors: External sensors T1 (GT1) and T2 (GT2) must always be connected. The sensor T4 (GT4) is only connected if a mixing valve is used. The sensor T5 (GT5) is connected when the heat pump is to be influenced by a room sensor.

An absolute prerequisite for the connection is that a minimum flow of at least 70% of the nominal flow can be maintained throughout the year.

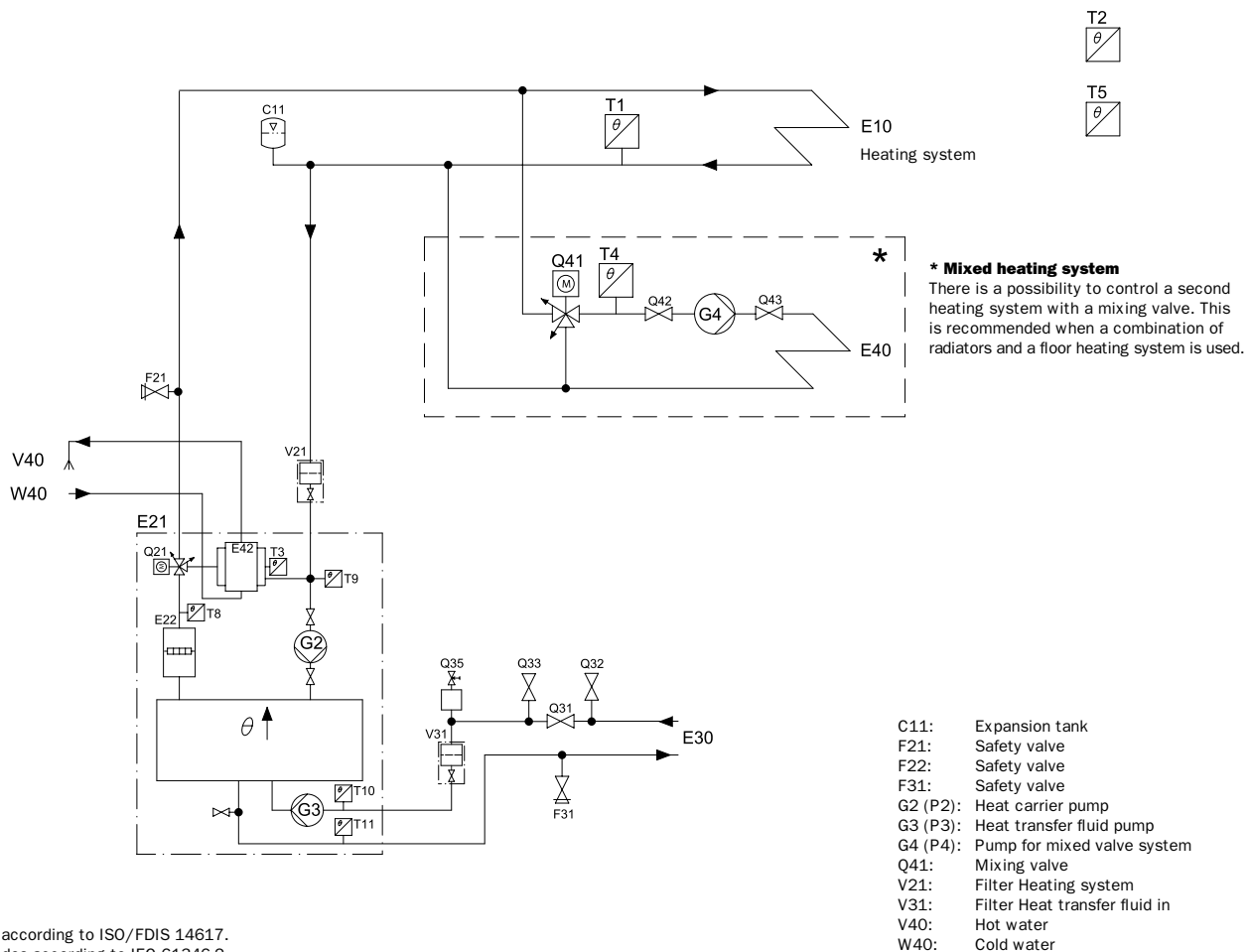

Symbols according to ISO/FDIS 14617.
Letter codes according to IEC 61346-2.
This is a principal drawing.

FOR THE INSTALLER

Connect heat pump E to the heating system

Application: The principle is based on floating condensing in the heat pump (curve control) and additional heat from the electric cassette. The built-in control unit controls the heat pump using the outdoor sensor T2 (GT2) and the return sensor T1 (GT1) according to the outdoor compensated control curve. When the heat pump is unable to meet the heating requirements, the electric cassette starts automatically and together with the heat pump provides the required temperature. The heating of hot water is given priority over the heating of the heating water. Hot water heating is controlled by the sensor T3 (GT3), which is located in the hot water cylinder. When the water in the cylinder is heated, a three-way valve temporarily disconnects heating radiator mode. When the water in the cylinder reaches the required temperature, heat is once more supplied to the heating system.

The control unit can also control a second curve together with a mixing valve. The mixing valve curve must be set lower than the heat curve for the rest of the heating system. This extra function is used, for example, in a floor heating system that requires a lower temperature.

Connecting the sensors: External sensors T1 (GT1) and T2 (GT2) must always be connected. The sensor T4 (GT4) is only connected if a mixing valve is used. The sensor T5 (GT5) is connected when the heat pump is to be influenced by a room sensor.

An absolute prerequisite for the connection is that a minimum flow of at least 70% of the nominal flow can be maintained throughout the year.

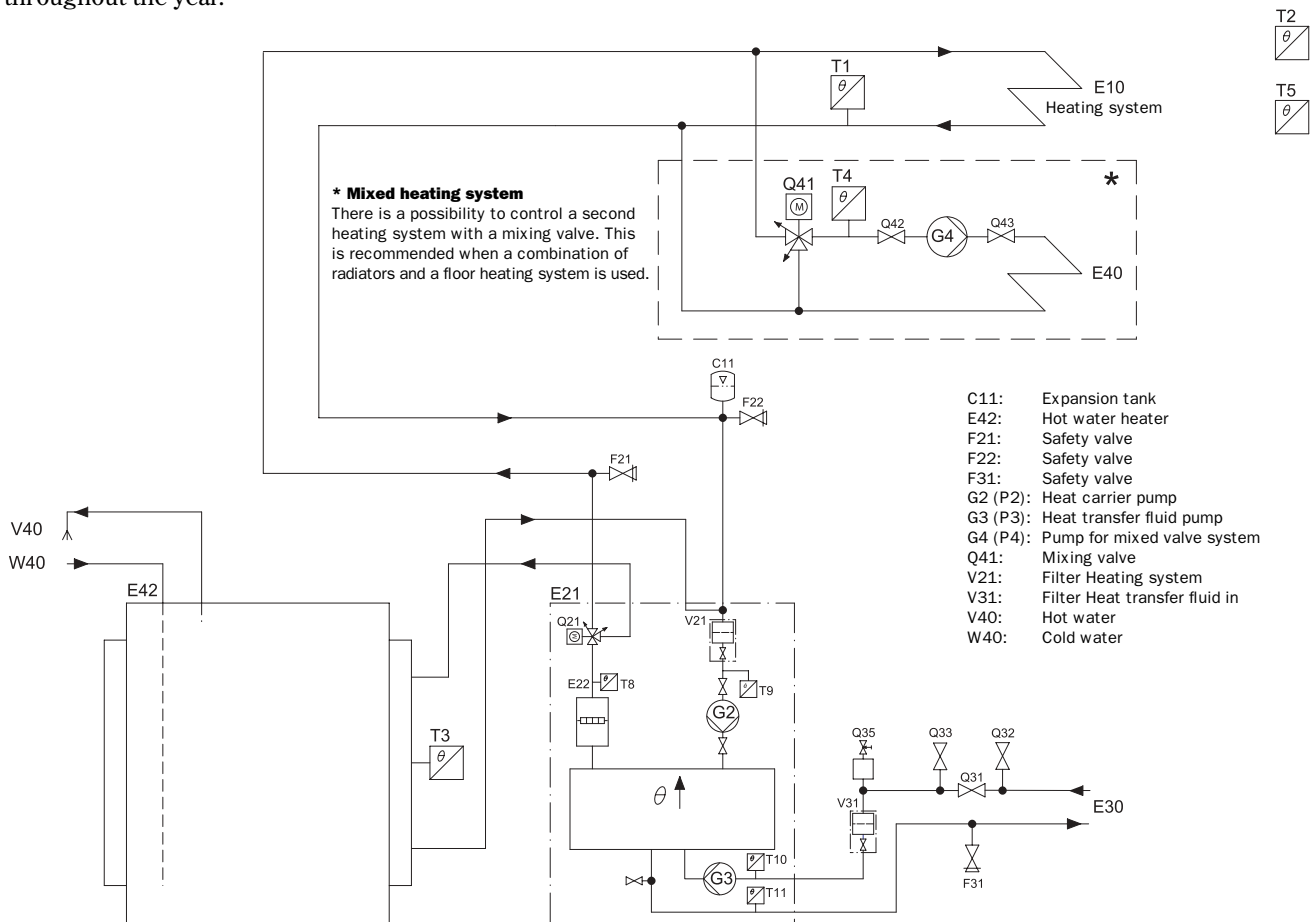

Symbols according to ISO/FDIS 14617.
Letter codes according to IEC 61346-2.
This is a principal drawing.

Connect the heat pump to a heating system with bypass

A connection with a bypass is necessary when a minimum flow cannot be guaranteed during the entire year.

Application: The principle is based on floating condensing in the heat pump (curve control) and additional heat from an electric cassette. The built-in control unit controls the heat pump using the outdoor sensor T2 (GT2) and the return sensor T1 (GT1) according to the outdoor compensated control curve. When the heat pump is unable to meet the heating requirements, the electric cassette starts automatically and together with the heat pump provides the required temperature. The heating of hot water is given priority over the heating of the heating water. Hot water heating is controlled by the sensor T3 (GT3), which is located in the hot water cylinder. When the water in the cylinder is heated, a three-way valve temporarily disconnects heating radiator mode. When the water in the cylinder reaches the required temperature, heat is once more supplied to the heating system.

The control unit can also control a second curve together with a mixing valve. The mixing valve curve must be set lower than the heat curve for the rest of the heating system. This extra function is used, for example, in a floor heating system that requires a lower temperature.

Connecting the sensors: External sensors T1 (GT1) and T2 (GT2) must always be connected. Sensor T3 (GT3) is connected if the heat pump is to produce hot water. Sensor T4 (GT4) is only connected if a mixing valve curve is used. Sensor T5 (GT5) is connected when the heat pump is to be influenced by a room sensor.

Accumulator tank: In systems where individual room temperature control is required, for example, with floor heating in one of the rooms, an accumulator tank of 100-300 litres is recommended. This is sufficient to ensure good operating times for the heat pump. T1 (GT1) should be installed according to T1* in the diagram below.

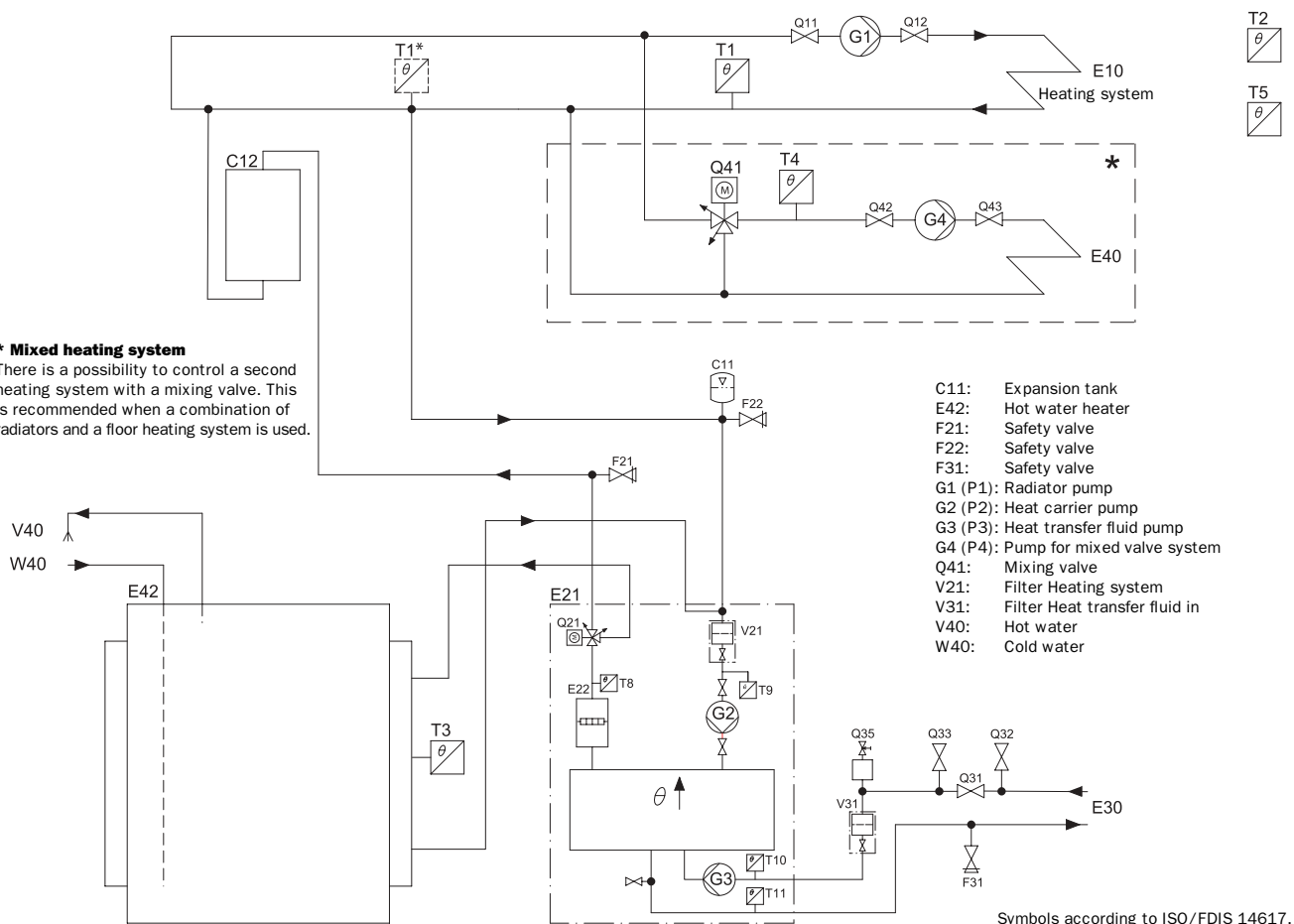

Symbols according to ISO/FDIS 14617.
 Letter codes according to IEC 61346-2.
 This is a principal drawing.

Filling water in the heating system

The heating system normally has an expansion vessel with a pressure gauge.

This is what to do:

1. Open and close the tap between the cold water system and the heating system in short time intervals.
2. Read the pressure on the pressure gauge.
3. Vent the system and refill to the correct pressure.

Filling the heat transfer fluid in the collector hose

The collector hose is filled with heat transfer fluid to be able to collect heat from the ground. The fluid is a mixture of water and anti-freeze. It should have a freezing point of approximately -15°C. The ratio between water and anti-freeze can be seen in the tables on the following pages.

Proceed as follows to fill the collector hose with heat transfer fluid:
See the illustration on the next page.

1. Connect two hoses (1 inch in diameter) to both filling valves 1 and 2. One of the hoses should have a submerged pump connected at the other end. The submerged pump should be fitted with a particle filter.
2. Place the hose and submerged pump in a barrel that holds 100 litres.
3. Fill the barrel with heat transfer fluid. The relation between water and heat transfer fluid can be found in the tables 1 and 2. Fill the water before anti-freeze liquid.
4. Open valves 1 and 2 and close valve 3.
5. Start the submerged pump. The circuit is automatically filled with heat transfer fluid.
6. Open valve 4 to the expansion vessel so that it fills with fluid (two thirds of the volume).



Note

The first litres from the return pipe are often contaminated. Therefore collect these litres in a separate tank.

7. When the fluid level has dropped to 25 per cent in the barrel, the submerged pump is stopped and the barrel is filled with more anti-freeze mixture.
8. When the system is full and air no longer comes from the return pipe run the system for at least a further 30 minutes. You can also start the heat transfer fluid pump to speed up the air venting. Enter manual operation under menu 5.3 and start the pump G3 (P3). See *Commissioning the heat pump/Testing the heat pump manually*.
9. When venting is complete open valve 3, shut valve 2, and shortly after shut also valve 1. Disconnect the hoses and the heat transfer fluid side is ready for operation.



Note

It is an advantage if an overpressure is created in the heat transfer fluid circuit. An underpressure damages the expansion vessel and the collector hose.



Tip

Manual venting valve

If the expansion vessel cannot be placed in the highest position in the room then manual venting is recommended.

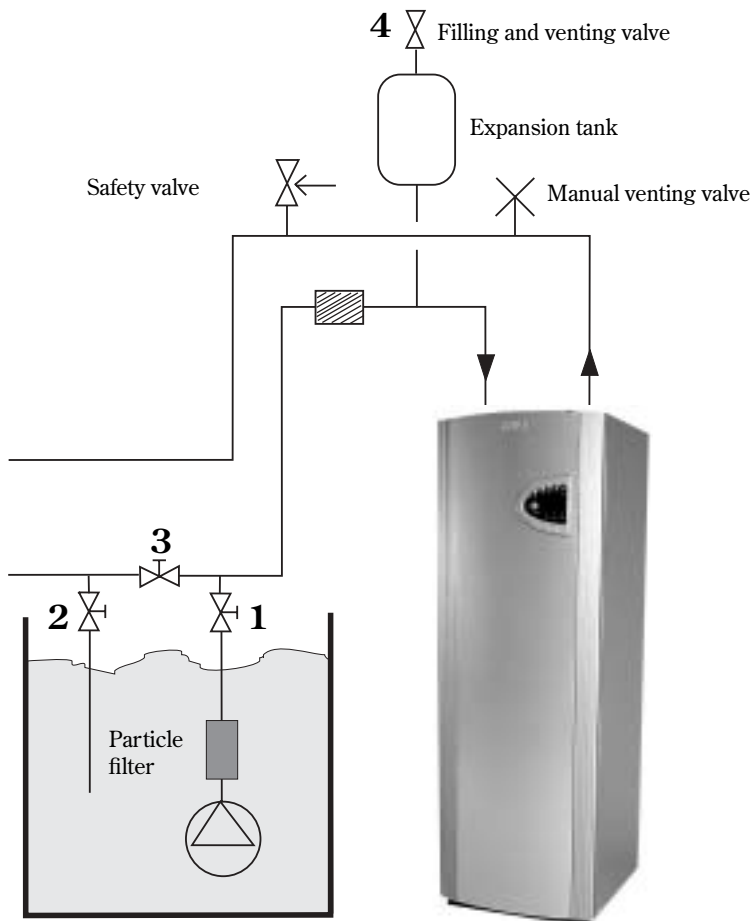

FOR THE INSTALLER

Table 1: Mixing ratio in litres/metre

Anti-freeze type	Hose type: 40/35		Hose type: 32/28	
	Water (l)	Anti-freeze (l)	Water (l)	Anti-freeze (l)
Ethanol	0.71	0.29	0.42	0.18
Propylene glycol	0.65	0.35	0.39	0.21

Example:

A 200 metres of hose type 40/35 with Brinol gives 200 x 0.29 litres Brinol/ metre = 58 litres of Brinol and 200 x 0.71 litres of water/ metre = 142 litres water.

Table 2: Mixing ratio in per cent by weight

Anti-freeze type	Hose type: 40/35	Hose type: 32/28
Ethanol	25 %	25 %
Propylene glycol	35 %	35 %

Installing the expansion vessel

It is important when installing the expansion vessel to position it at the highest point in the circuit, preferably above the heat pump. If there is a low ceiling making it impossible to fit the tank above the pump, it can be positioned as illustrated in the figure to the left. It is important to install the tank so that any air disappears upwards. Air will remain in the circuit if the tank is fitted incorrectly (see the figure to the right).

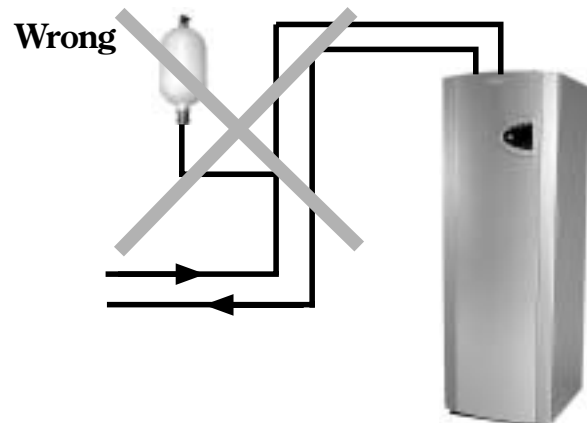
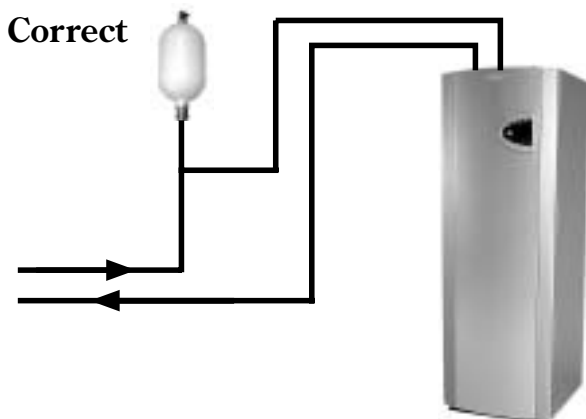

Connecting the heat pump to the power supply

Make sure the electricity has been switched off before connecting the heat pump to the mains. Check that cables and printed circuit cards are intact. High and low current cables should be routed separately in order to avoid interference on the sensors.

Wiring diagram supplied with the heat pump.

A description of external connections is given in this section. Examples of external connections include room and outdoor sensors and mixing valves.



Warning

The electrical installation may only be performed by a qualified electrician.

For reasons of safety the main power supply must be disconnected before working on the heat pump.

Safety switch and earth-fault breaker

Safety switch

All heat pumps must be fitted with a safety switch.

Earth-fault breaker

If the heat pump is to be connected across an earth-fault breaker then a separate earth-fault breaker for the heat pump is recommended. Comply with applicable regulations.

External connections to the heat pump

These are the external connections that must be made for the heat pump:

- **Power supply:** The power supply is connected to terminals L1, L2, L3, N and PE. In the event of a possible phase sequence fault the heat pump will trip the alarm “PHASE SEQUENCE ERROR”. See more information in the section *What to do if a fault occurs*.
- **Mixing valve on the heating circuit:** If a second heat curve with a mixing valve is to be used, the mixing valve is connected to terminal block SV1.
- **External main pump in the heating system G1 (P1):** The external main pump should be connected to the terminal card in those cases a bypass is required. The pump is connected to terminal P1.
- **Return sensor radiator T1 (GT1):** Must always be connected. Connect to terminal GT1.
- **Outdoor sensor T2 (GT2):** Must always be connected. Connect to terminal GT2.
- **Hot water sensor T3 (GT3):** Connected if the heat pump is to produce hot water. Connect to terminal block GT3 X on the terminal card. On the C model this sensor is already connected on delivery.
- **Mixing valve sensor T4 (GT4):** Is connected when a mixing valve for a second heat curve is to be used. Connect to terminal GT4.
- **Room sensor T5 (GT5):** Connected if room sensor influence is required. Connect to terminal block GT5 on the terminal card. The alarm lamp in the room sensor is connected to the terminal block ALARM LED.

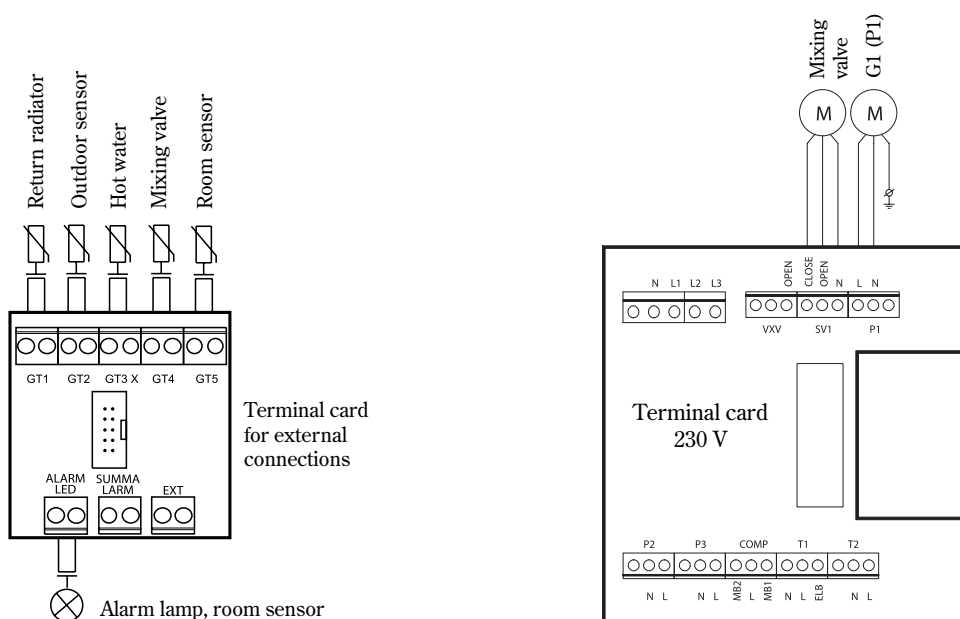

Connecting the general alarm, external input and load monitor

General alarm

The general alarm is activated irrespective of which alarm has tripped. When a common alarm is required on the heat pump, it is connected according to the diagram opposite. The contact for the general alarm output is potential free (no current) and it closes at a general alarm.

Connect max 24 V and 100 mA on the contact.

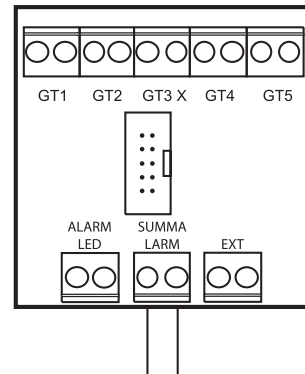

Terminal card for external connections

External input

The heat pump includes prepared functions to permit the heating to be controlled externally, for example, from a telephone. The input to the heat pump can be programmed for different functions on the control unit. These functions are available from menu 1.13 (Remote control heat) and menu 5.7 (Select external controls).

The input must be short circuited to activate the function. Note that the contact must be potential free.

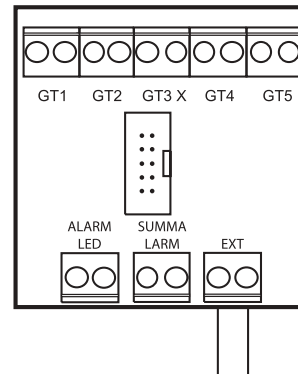

Terminal card for external connections

Load monitor

The load monitor has the task of disconnecting the additional heat in the event of a too high load on the house's main fuse. Connect the load monitor to the external output according to the heading External input above. Select function 3 in the menu display 5.7 (Select external controls). When the external input has been short circuited the additional heat is disconnected. The heat pump is not affected.

Note: It is not possible to utilise the other functions in menus 1.13 and 5.7 if you connect a load monitor.

Installer and service menu (I/S)

As the installer you have your own section of menus for settings, e.g. for commissioning. These are accessed from the control panel by holding down the menu button for approximately ten seconds.

The menu displays are divided into lines and each display has a number to make it easy to find. If there is no activity for 30 minutes the menu display automatically returns to customer level 1.

The installer level also includes customer levels 1 and 2.



Warning

The installer and service menu (I/S) is only for installers. Under no circumstances may the user access this level.

How to use the control panel

Here follows an example of how to use the control panel. The example shows how you move to menu display 5.13 and confirm the external sensors. You will also find more information about the control panel under the heading *Control Panel* in the User section.

1. Press the menu button for approximately ten seconds until Access = SERVICE is shown on the menu display. Now press the Menu button.
2. The menu display *Indoor temperature settings* (menu 1) is shown.
3. Turn the menu dial clockwise (to the right) until you access the menu *Commiss./Service for installer* (menu 5). Now press the Select button.
4. Turn the menu dial clockwise until you reach the menu *Connected extra sensor in op.* (menu 5.13). Now press the Select button.
5. The display window *Extra sensor* is shown. Confirm the extra sensors that you have connected by pressing the Confirm button.
6. The text *Ackn...* is briefly shown in the menu display. This means your setting is being registered in the heat pump.
7. When the setting has been registered the previous menu display is shown. Press the Return button twice to return to the main menu.

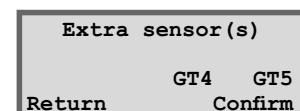
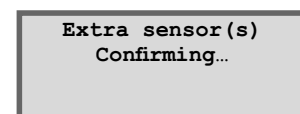
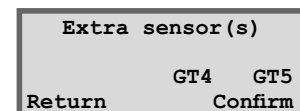
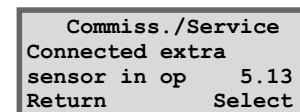
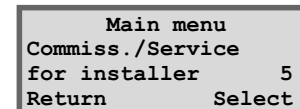
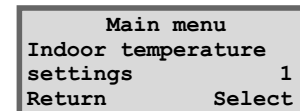
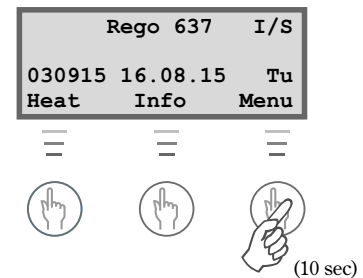

Commissioning the heat pump

The heat distribution and heat transfer fluid circuits should be filled and fully vented before commissioning. Also check that there are no leaks.

As many radiators as possible should be fully open when connecting to an existing water system. When connecting to a floor heating system at least half of all the floor coils should be open. When connecting a fan-assisted radiator system the fans are started first and then the taps on the fan-assisted radiators are opened fully.

Start the heat pump

1. Connect mains to the heat pump and press the ON/OFF switch on the control panel. The control unit automatically measures the phase sequence so the compressor does not operate in the wrong direction. If the phase sequence is wrong the alarm "Phase sequence error" will trip. Read more about the alarm under the heading *What to do if a fault occurs*. Disconnect the mains power to the heat pump and switch the phases manually.
2. Activate the Installer/Service menu by pressing the Menu button until the text ACCESS = SERVICE is shown on the menu display.
3. Set *Temp. incr. / decr.* temporarily to the maximum value. To avoid having to wait for the heat pump restart timer you can go to the menu *Fast restart of heat pump* (menu 5.6) and quickly restart the heat pump. If the heat pump does not start, press the Info button to see if a heating demand exists.
4. Check the sight glass inside the heat pump during start up. Bubbles may appear in the sight glass for a few minutes during start up. The bubbles should then stop. Bubbles present when the heat pump is running are a fault symptom. They are probably due to insufficient refrigerant. Read more about the fault symptom under the heading *What to do if a fault occurs*.
5. Make the necessary settings on the control panel.
 - a. Confirm connected external sensors. If T3 (GT3), T4 (GT4) or T5 (GT5) have been connected, you must confirm these so the control unit knows they are installed. The displays presented by the sensors are only shown if the sensors have been confirmed.
 - b. Set the maximal output to be used by the electric cassette. Choose between 1/3, 2/3 and 3/3. It is important that the electrical installation is adapted to handle the maximum electrical output. IVT supplies the control unit set to 2/3. For more information about this see the heading *Technical information*.



Note

Further important information on control unit can be found in the user section.

Read the User section too before commissioning is started.



Press the power switch ON/OFF

Rego 637	I/S
030915	16.08.15 Tu
Heat	Info Menu

Commiss./Service	
Fast restart of	
heat pump	5.6
Return	Select



Check the sight glass

Commiss./Service	
Connected extra	
sensor in op	5.13
Return	Select

Commiss./Service	
Select conn capacity	
electrical cass	5.2
Return	Select

Menu displays you might need to adjust or check

Temperature settings

Set the hysteresis for heat pump on/off switching on the return sensor T1 (GT1). A lower value gives a shorter interval between start and stop. Less than 5°C should be avoided.

Temperature settings	
Heat curve	
hysteresis	1.4
Return	Select

Set the neutral zone for the mixing valve in a heating system with two heat curves. In the neutral zone the mixing valve receives no signal to open or close. Only applies when the sensor T4 (GT4) is connected.

Temperature settings	
Mixing valve curve	
neutral zone	1.8
Return	Select

Set the maximum temperature in the mixing valve circuit. You can, for example, set a maximum temperature for the floor heating system. On delivery of the heat pump the value is 60°C. Only applies when the sensor T4 (GT4) is connected.

Temperature settings	
Mixing valve curve	
max at GT4	1.9
Return	Select

Hot water settings

Set the temperature in the hot water heater's outer shell. Note that the setting does not apply to the temperature inside the hot water heater. The factory setting is 51°C, but this temperature can be increased to max 54°C if necessary. Only applies when the sensor T3 (GT3) is connected.

Hot water setting.	
Setting of	
temperature.	2.3
Return	Select

Set the hysteresis for the hot water temperature. The function measures below and above the value set in menu 2.3. Only applies when the sensor T3 (GT3) is connected. Less than 4°C should be avoided.

Hot water setting.	
Setting of	
DHW hysteresis	2.4
Return	Select

Clock setting of additional heat

You can set the control unit so that the additional heat is fully blocked during certain periods of the day. Read more under the heading *Extra functions (Customer level 2)/Timer control* about how to set the control unit.

Clock setting	
Clock sett. add heat	
accord. to clock	4.2
Return	Select

Commissioning/Service

Make a check of all the functions before you commission the heat pump. You can manually start and stop the pumps and valves from the menu *Manual operation of all functions*.

Commiss./Service	
Manual operation of	
all functions	5.3
Return	Select

Set when the additional heat should be activated. On delivery the heat pump is set to activate the additional heat when necessary. Choose between Yes or No. If you choose No, the additional heat only engages during alarms, extra hot water and hot water peaks.

Commiss./Service	
Select function	
add.heat yes/no	5.5
Return	Select

The function Fast restart means you do not have to wait for the normal restart time to start the heat pump. If there is a need for heating or hot water the heat pump starts within 20 seconds. The setting must be repeated each time you need to make a fast restart.

Commiss./Service	
Fast restart	
of heat pump	5.6
Return	Select

In the menu 5.7 you set whether the heat pump, additional heat and hot water charging should be controlled externally. When the external input on the control unit is short circuited you can make one of the following choices:

- 0: No effect (factory setting).
- 1: HP, additional heat and hot water stop.
- 2: HP no effect, additional heat and hot water stop.
- 3: HP and hot water no effect, additional heat stops.
- 4: HP and additional heat no effect, hot water stops.

```

Commiss./Service
Select external
controls      5.7
Return       Select
  
```



Note

If any of the alternatives to the left are selected it is not possible to utilise any of the functions in the menu *Remote control heating* (menu 1.13). See *Extra functions* in the user section.

Select the language that you would like for the menu texts. On delivery the language setting is set to Swedish.

```

Commiss./Service
Selection of
language menu  5.8
Return       Select
  
```

The heat pump is set for continuous operation of the heating carrier pump on delivery. In systems with a bypass, you can choose whether the heating carrier pump starts and stops with the compressor.

```

Commiss./Service
Select operation
alt. for P2    5.10
Return       Select
  
```

Choose whether the HTF pump shall run continuously, for example, when using *natural cooling. The heat transfer fluid pump should normally always start and stop with the compressor. On delivery the heat pump is set to start and stop with the compressor.

```

Commiss./Service
Select operation
alt. for P3    5.11
Return       Select
  
```

Select this menu to see the version number of the control unit.

```

Commiss./Service
Display software
version number 5.12
Return       Select
  
```

Confirm the extra sensors T3 (GT3), T4 (GT4) and T5 (GT5) that are connected externally. On confirmation, the control unit stores information about the sensors to be used.

```

Commiss./Service
Connected extra
sensor in op   5.13
Return       Select
  
```

Timer readings

There are a number of different menu displays to help you check the status of the heat pump. The heat pump status is shown by the timer readings in menu 6.

Reading the DHW peak timer

The function shows the status of when the next hot water peak will be carried out. If the timer shows zero the hot water peak will be activated the next time there is a hot water requirement.

```

Timer readings
Read
DHW peak timer 6.1
Return       Select
  
```

* Natural cooling: In winter the heat pump takes heat from the bore hole in the rock and converts this to heat in the house. In the summer the cold in the same bore hole is used to give pleasant air conditioning.

Read the additional heat timer

The function shows the amount of time remaining before the additional heat is activated. If there is no countdown then there is no need of additional heat.

```

Timer readings
Read
add. heat timer 6.2
Return          Select
  
```

Reading the alarm timer

The function gives you information about an alarm. If the heat pump has stopped, a countdown starts from 60 minutes (3600 seconds). When the time has elapsed and the alarm has not been rectified, the additional heat starts so that the house will not be cold and to produce hot water.

```

Timer readings
Read
alarm-timer      6.3
Return          Select
  
```

Read the start delay

The function shows the time remaining until the heat pump starts again after a previous stoppage. The heat pump will not start if there is no heating or hot water need.

```

Timer readings
Read
start delay     6.4
Return          Select
  
```

Setting the additional heat**Add. heat timer**

The function gives you the possibility to set the time that should elapse before the additional heat starts if the heat pump cannot produce sufficient heat on its own. On delivery the heat pump is set to one hour.

```

Additional heat
Setting of
heat timer      8.1
Return          Select
  
```

Ramp time open

Here you set the time that you would like the immersion heater to go from 0 to 100%. In some cases the ramp time open, may need to be adjusted to eliminate overexciting the system.

```

Mixed add. heat
Setting of
ramp time open 8.3.4
Return          Select
  
```

Ramp time close

Here you set the time that you would like the immersion heater to go from 100 to 0%.

```

Mixed add. heat
Setting of ramp
time close     8.3.5
Return          Select
  
```

Show connected elec. capacity

Check how much additional heat (per cent) has been enabled. See more information under the heading *Technical information*.

```

Additional heat
Show connected elec.
capac. in op.  8.5
Return          Select
  
```

Return to factory settings

If you regret your settings you can return to the factory settings in menu 12. If you are on customer level 1 or 2 when you select *Return to factory settings*, only the settings in the displays accessible from customer level 1 and 2 will be reset. If you are on the Installer/Service level when you select *Return to factory settings* only the displays accessible from Installer / Service level are reset.

```

Main menu
Return to
factory settings 12
Return          Select
  
```

Manual test run of the heat pump

Instead of starting the heat pump directly in normal mode, you can manually test run the pumps and valves. This is recommended as in this mode you can easily find any possible faults. In the menu display *Manual operation of all functions* (menu 5.3) you can run all functions manually. Press the Select button to start test operations. When you exit from the menu display the heat pump returns to normal mode.

Commiss./Service	
Manual operation of	
all functions	5.3
Return	Select

Start the heat pump with only additional heat

It might be necessary to run the heat pump before work on the heat transfer fluid circuit is complete. You can then start the heat pump with only additional heat. You must have filled and vented the heating system to run the heat pump with only additional heat. Go to the menu display *Select the function only additional heat* (menu 5.4) and press the Select button. If the arrow points towards Normal mode press the Adjust button. Turn the menu dial until the arrow points towards *Additional heat only*. Now press the Save button. This function ensures that additional heat heats both the hot water and the heating water.

Commiss./Service	
Select function	
only add. heat	5.4
Return	Select



Note

Do not forget to return this function to normal mode.

Important points to check after start up

In the first period after commissioning particular attention should be paid to the pressure and levels in the heat distribution and heat transfer fluid circuits. After a short period of operation it may be necessary to top up the heat transfer fluid.

On delivery the motor cut-out setting is determined by a value produced during hot water charging and a stable voltage. The recommended motor cut-out setting may not always be suitable as the voltage in the mains can fluctuate. The setting may therefore, from case to case, need to be adjusted. Adjust the setting using a clip-on ammeter when the heat pump is producing hot water.

For the heat pump to perform at its best, it is important to check the flow on the hot side of the heat pump. Usually, the heat carrier pump has a speed selector switch. This must be set correctly for the pressure drop in the systems. A recommended temperature difference over the heat pump on the hot side is between 7-10 °C and on the cold side between 2-4 °C. You check this by going to menu display 3 and reading the sensors T8 (GT8) and T9 (GT9) as well as T10 (GT10) and T11 (GT11).

It is important in systems with a bypass that the flow in the heating system exceeds the flow over the heat pump. If this is not the case, the heat pump flow goes back via the bypass to the heat pump return, which may cause the heat pump to give an alarm for a high return temperature. The flow over the heating system should be so great that the entire radiator surface is kept warm. In this way the heat emitting surface increases and in doing so the flow temperature from the heat pump is kept down.

The heating system should be vented once again after test operations and then filled with cold water if necessary.

Technical information

The heat pump's factory settings

The table shows the factory settings for all the settings that can be changed by the installer.

Menu	Setting	Factory setting
1.1	Temp. incr. / decr.	4
1.2	Temp. fine-tune	0°
1.3	Heat curve adjustment	0°
1.4	Heat curve hysteresis	5°
1.5	Mix. valve incr/decr	4
1.6	Mix. valve fine-tune	0°
1.7	Adapting the mixing valve curve	0°
1.8	Mix. valve curve neutral zone	3°
1.9	Mixing valve curve max at GT4	60°
1.10	Setting the room temperature	20°
1.11	Setting the room sensor influence	5
1.12	Setting of holiday function	0 days
1.13	Remote control temperature	not active
1.14	Setting of summer disconnection	18°
2.1	Number of hours for extra hot water	0 hours
2.2	hot water peak menu is used	not active
2.3	Setting of room hot water temperature.	51°
2.4	Setting of DHW hysteresis	4°
4.1	Clock setting HP accord. to clock	not active
4.1.1	Setting level heat pump +/-	0°
4.2	Clock setting additional heat according to clock	not active
4.3	Clock setting hot water according to clock	not active
5.2	Select conn capacity electr. cass.	2/3
5.4	Select the function only additional heat	off
5.5	Select function additional heat	yes
5.7	Selecting external controls	0
5.10	Selection of the operation alt. P2	P2 cont. operat
5.11	Selection of the operation alt. P3	P3 with comp.
8.1	Setting the additional heat timers	60 minutes
8.3.4	Ramp time open	20 min
8.3.5	Ramp time close	3 min

Sensor table

The table shows all sensor resistance at different temperatures.

Temperature (°C)	kΩ
-40	154.300
-35	111.700
-30	81.700
-25	60.400
-20	45.100
-15	33.950
-10	25.800
-5	19.770
0	15.280
5	11.900
10	9.330
15	7.370
20	5.870
25	4.700
30	3.790
35	3.070
40	2.510
45	2.055
50	1.696
55	1.405
60	1.170
65	0.980
70	0.824
75	0.696
80	0.590
85	0.503
90	0.430

Technical information

Model Greenline HT Plus		C/E 6	C/E 7	C/E 9	C/E 11	E 14	E 17	
Emitted /Supplied output at 0/35°C ¹	kW	5,9/1,3	7,3/1,6	9,1/2	10,7/2,2	14,4/3,1	16,7/3,7	
Emitted /Supplied output at 0/50°C ¹	kW	5,4/1,7	6,9/2,1	8,4/2,6	10,1/3,0	13,9/4,2	16,2/4,9	
Minimum flow heating medium	l/s	0,14	0,18	0,22	0,26	0,35	0,40	
Nominal flow heating medium	l/s	0,20	0,25	0,31	0,37	0,50	0,57	
Permitted ext. pressure drop heating medium nominal flow	kPa	36	36	34	33	54	51	
Nominal flow cooling medium	l/s	0,30	0,38	0,46	0,57	0,78	0,90	
Permitted ext. pressure drop cooling medium nominal flow	kPa	49	45	44	80	74	71	
Max pressure radiator system	bar	1,5						
Max pressure cooling medium system	bar	4						
Highest outgoing heating medium temperature	°C	65						
Operating temperature heat transfer system	°C	-5 to +20						
Integrated heat/HTF pump		Yes						
Electrical supply		400V 3N~ 50Hz						
Add. heat reconnectable	kW	3.0 / 6.0 / 9.0						
Recommended fuse size depends on electrical additional heat ²								
Electric cassette 6 kW	A	16	16	20	20	20	25	
Electric cassette 9 kW	A	20	20	25	25	25	32	
Compressor		Scroll						
Refrigerant R407C	kg	1,35	1,4	1,5	1,9	2,2	2,3	
Connection, heating medium	Cu	22	22	22	22	28	28	
Connection, cooling medium	Cu	28	28	28	28	35	35	
Dimensions E-model (WxDxH)	mm	600x600x1520						
Weight E-model	kg	146	152	155	170	190	195	
Dimensions C-model (WxDXH)	mm	600x600x1800					-	-
Weight C-model Copper/Stainless hw-cylinder	kg	230/200	231/201	240/210	218	-	-	
Integrated double-shelled HW-cylinder on the C-model. Copper or stainless ³		Copper / stainless	Copper / stainless	Copper / stainless	Stainless	-	-	
Domestic hot water C-model	litres	165	165	165	165	-	-	
Control unit		Rego637						

¹ Output data at 0/35°C and 0/50°C and min heating medium flow are stated according to the European standard EN 255. Additional heat not included.

² Melt fuse breaker type gL-gG or miniature circuit breaker with characteristic C.

³ Anode included with C-models with stainless hot water cylinder.

Index

Symbols

3-phase incorrect..... 37

A

Acknowledge button..... 32
 Adapting the heat curve 22
 Additional heat 10, 26
 Additional heat status 12
 Alarm..... 32, 33
 Alarm status..... 12
 Anod 30

B

Basic functions 13, 14
 Boiling point 6

C

Care 28
 Circlip 30
 Cold weather..... 16
 Component parts of the heat pump 8
 Compressor 6, 7, 8, 9
 Compressor temperature 35
 Condenser..... 6, 8
 control method 11
 Control panel 8, 12
 Control unit..... 8, 9, 10
 Curve slope..... 15
 Customer level 1 13
 Customer level 2 21

D

Date 13, 26

E

Electrical box..... 8, 9
 Electrical connection 9
 Electrical connections 8
 Electric cassette 36
 Electric water heater..... 8, 9
 Evaporator 6, 8
 Expansion valve..... 6, 8, 9
 Expansion vessel..... 29
 Extra functions 21

F

Factory settings 27
 Flexible hoses..... 8, 9
 Front cover 28
 Fuses 32, 33

H

Heating water 10
 Heat carrier pump..... 8, 9, 36
 Heat curve 15
 Heat distribution system delta..... 37
 Heat pump malfunction 32
 Heat transfer fluid 7, 38, 39
 Heat transfer fluid pump 8, 9
 High heat distribution system delta..... 37
 High pressure switch..... 36
 High return..... 38
 Holiday mode 22
 Hot water..... 10
 Hot water cylinder..... 8, 10
 Hot water peak 24
 Hot water settings 19, 24
 Hot water status 12

I

Info button 32
 Initial menu..... 13, 21

L

Low pressure switch 35

M

Menu buttons 12, 13
 Menu dial 12
 Menu outline 21
 Menu overview..... 14
 Menu windows 12
 Miniature circuit-breaker 32, 36
 Motor cut-out compressor 34
 Motor cut-out HTF pump 34

O

Operating status..... 12
 Operating times..... 26
 Outdoor sensor..... 11
 Outdoor temperature..... 15

P

Partical filter	30
Particle filter	9, 30, 33
Power failure.....	37
Power switch	12
Protective anode.....	30

R

Remote control	22
Reset button.....	8, 9, 33
Return temperature	15
Room sensor	11
Room sensor influence	22

S

Savings	31
Screen.....	30
Sealing cap	30
Sensor fault	39
Sight glass.....	8, 28, 33
Status lamps.....	12
Summer disconnection.....	22

T

Temperature readings	20
Three-way valve.....	9
Three way valve.....	8
Tillskott	12
Time	13, 26
Timer control.....	24

W

Warm weather	17
Working temperature	35



IVT Industrier AB, Sweden
www.ivt.se | mailbox@ivt.se