

**JanusRAID II SA-6651E  
Hardware User Manual**

**4G Fibre Channel to Serial ATA II**

**Disk Array System**

**Version 1.0**





# **SA-6651E**

**4G Fibre Channel to Serial ATA II**

**Disk Array System**

**Hardware User Manual**



# Table of Contents

Preface.....	i
--------------	---

---

## Chapter 1 System Requirements

Operating Environment .....	1
Host Interface-4G Fibre Channel .....	1
Hard Disk Interface-SATA II .....	1
VT100 Terminal Settings .....	2
Ethernet settings .....	2

---

## Chapter 2 Basic Configuration

Unpacking .....	3
Components .....	4
Closed Front Panel .....	4
Open Front Panel .....	5
Disk Tray .....	6
SA-6651E Rear View .....	7
Installing Disks .....	8
Making Connections .....	10
Connecting the Host Interface .....	10
Connecting the GUI management port .....	11
Connecting the JBOD enclosure .....	11
Connecting and Turning on the Power .....	12
Mounting in a Rack .....	13
Installing the Rail Extenders .....	14

---

## Chapter 3 Maintenance

Replacing a Disk .....	15
Replacing a Power Supply .....	16
Upgrading Memory .....	17
Replacing a FAN module .....	18

---

## Appendix

Hardware Specifications .....	19
-------------------------------	----



# Preface

## About this Manual

This manual is designed to make the disk array system as easy to use as possible. Information contained in this document has been checked for accuracy, but no guarantee is given that the contents are correct. Information and specifications are subject to change without notice.

## Copyright Notice

© Copyright 2007 MaxTronic International Co., Ltd.

All rights reserved. This disk array system and related documentation are protected by copyright and are distributed under licenses restricting their use, copying, and distribution. No part of this documentation may be reproduced in any form by any means without prior written authorization of MaxTronic International Co., Ltd. and its licensors, if any.

## Conventions



### Caution

This symbol is used to remind users to pay attention to important descriptions regarding usage and maintenance (repair) or additional important information related to this disk array system.

---



### Note

This symbol is used to remind users of useful information that can make procedures such as configuration easier to accomplish.

---

## Important Safety Instructions, Care and Handling



Before starting, take a few minutes to read this manual. Read all of these instructions and save this manual for later reference.



Protect the disk array system from extremely high or low temperatures. Let the disk array system warm (or cool) to room temperature before using it.



Protect the disk array system from being bumped or dropped. Do not place the disk array system on an unstable cart, stand, or table. It may fall, causing serious damage to the product.



Keep the disk array system away from magnetic forces.



Do not use the disk array system near water.



Keep the disk array system away from dust, sand, or dirt.



Gaps and openings in the cabinet are provided for ventilation. Never block or cover these openings, because the disk array system may overheat and become unreliable. Don't place the disk array system on a bed, sofa, rug, or other similar surface.



Do not place the disk array system near or over a radiator or other heat source.



Refer to the rating plate for the correct voltage and ensure that the appliance voltage corresponds to the supply voltage.



	<p>The appliance must be grounded. The disk array system is equipped with a 3-wire grounded type of power cord. This power cord will only fit into a grounded type of power outlet.</p>
	<p>If an extension cord or a power center is used with the disk array system, make sure that the total current consumption of all products plugged into the wall outlet does not exceed the ampere rating.</p>
	<p>Do not place the disk array system where the cord will be walked on.</p>
	<p>Never push any kind of object into the disk array system through cabinet gaps and openings, since they may touch dangerous voltage points and cause a risk of fire or electric shock.</p>
	<p>Unplug the power cord from the wall outlet before cleaning. Keep the disk array system dry. Do not use liquid cleaners, aerosol cleaners, or a wet cloth. Use a damp cloth for cleaning.</p>
	<p>Except as specifically explained in this User Manual, do not attempt to service the disk array system by yourself. Opening or removing the covers may expose you to dangerous voltages.</p>
	<p>Unplug this product from the wall outlet and refer servicing to qualified service personnel under the following conditions.</p> <ul style="list-style-type: none"> <li>• If the disk array system has been exposed to water or any liquid.</li> <li>• If the disk array system has been dropped or the cabinet damaged.</li> </ul>
	<p>Users should not remove the cover.</p>
	<p>Disconnect all power supply cords before servicing.</p>

---

### Placement Notes



- The disk array system LCD panel can be damaged by exposure to direct sunlight. Limit exposure to subdued or indirect sunlight only.
- The disk array system should be used only in clean environments that are free from airborne contaminants such as dust, dirt, and smoke. Excessive moisture or oil particles in the air can also hinder disk array system performance.
- To reduce the possibility of data errors caused by electromagnetic interference, locate the disk array system at least five feet away from electrical appliances and equipment that generates magnetic fields.

---

### Power Supply Safety Notes



- To avoid electric shocks, do not use an extended power cord or an outlet that does not match the disk array system plug or leaves the plug exposed.
  - The disk array system has a 3-wire grounded plug. The third pin connects to ground; do not remove it.
  - If the power cord or plug is damaged or worn, unplug it immediately and contact a qualified service technician for maintenance.
  - To avoid fire or electric shocks, do not overload electric power outlets.
-

# 1 System Requirements

Ensure that the following requirements are met before installing the disk array system.

## Operating Environment

- 15 cm (6-inches) of space around the disk array system for proper ventilation
- ambient temperature of 5°C to 40°C (40°F to 104°F)
- ambient non-condensing relative humidity of 10% to 85%
- dust, smoke, and oil free environment
- no large magnetic fields, such as those generated by a high voltage power cables and motors, etc.
- no direct sunlight
- a flat, stable surface capable of supporting the disk array system

## Host Interface - 4G Fibre Channel

The SA-6651E has dual 4 Gbit fibre channel interfaces with SFP connectors for linkage to a fibre channel switch or host computer interface card. With the correct SFP transceiver and optical cable, the following transmission distances can be achieved.

Component	Optical	
SFP Transceiver	LC Optical	
Cable	Short Wave	Long Wave
Maximum Cable Length	50m	10 Km

## Hard Disk Interface - SATA II

SA-6651E supports up to sixteen of quantities of both SATA I / II (1.5Gbps / 3Gbps) disks. All disk tray is hot-swappable.

## VT100 Terminal Settings

Refer to the following table for a summary of VT100 terminal settings required to communicate with the disk array system. Refer to your system manual for instructions on setting up the VT100 terminal settings.

Item	Required Setting
Connection	Serial Port (COM1 or COM2)
Protocol	RS232 (Asynchronous)
Cabling	Null Modem cable
Baud Rate	115200
Data Bits	8
Stop Bit	1
Parity	None

## Ethernet settings

SA-6651E supports DHCP (Dynamic Host Configuration Protocol) to get a IP address or a default IP is 192.168.0.1; You could find it from LCD scrolling. SA-6651E had embedded CGI-based GUI (graphic user interface) management interface can be easily accessed through a web browser.

# 2 Basic Configuration

This chapter describes disk array system connections and disk installation.

## Unpacking

Contact your supplier if any of the following items are missing or damaged.

---

### Caution



The disk array system is heavy. Be careful when lifting and moving it.

---

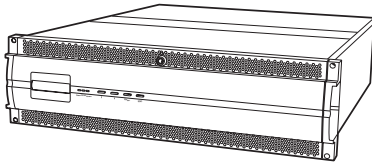

**Disk Array System**



**Hardware and software user Manuals**

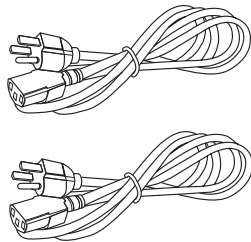

**Power Cables**

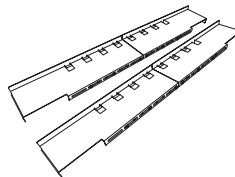

**Rails**

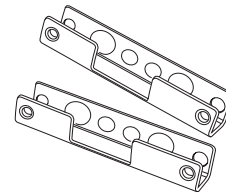

**Rail Extenders**

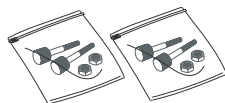

**Fix Screw pack M5**

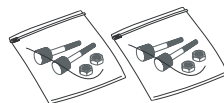

**Fix Screw pack M6**



**Front Panel Keys**

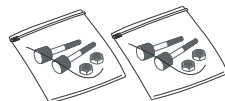

**Fix Screw pack  
UNC #10-32**



**HDD Screw pack**

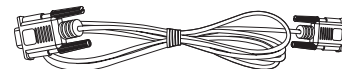

**RS-232 Cable**

# Components

## Closed Front Panel

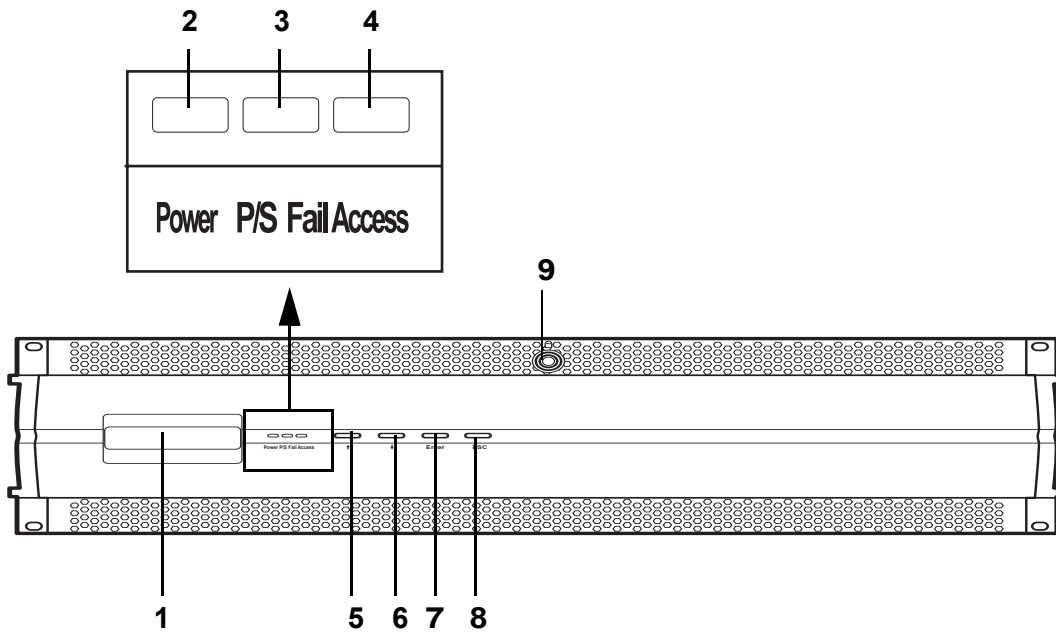

No.	Name	Description
1	LCD panel	Displays warning, operating, and configuration information.
2	Power-on indicator	Indicates the disk array system power is on.
3	Power supply fail indicator	Indicates a failed power supply.
4	Host computer access indicator	Indicates data transfer between the disk array system and the host computer.
5	Up function button	Moves up in the LCD menus.
6	Down function button	Moves down in the LCD menus.
7	Enter function button	Selects a menu item or confirms a choice or entry.
8	Escape function button	Returns to the previous LCD menu without making changes.
9	Lock	Locks front cover.

# Open Front Panel

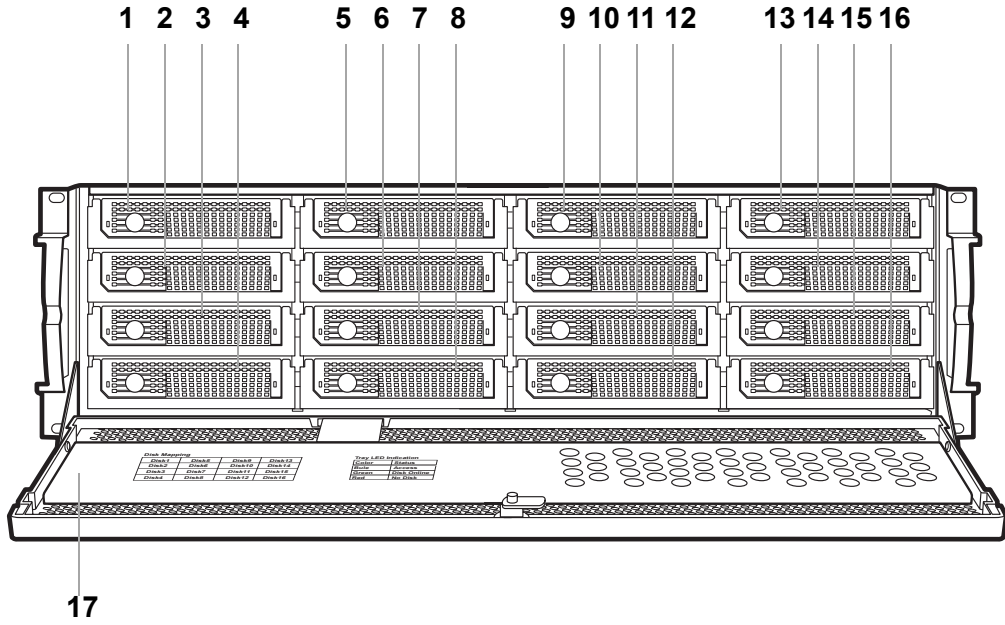

No	Name	Description
1-16	Disk trays 1-16	Removable hot swap disk trays
17	Front panel door	Protects the disks and houses the LCD panel

# Disk Tray

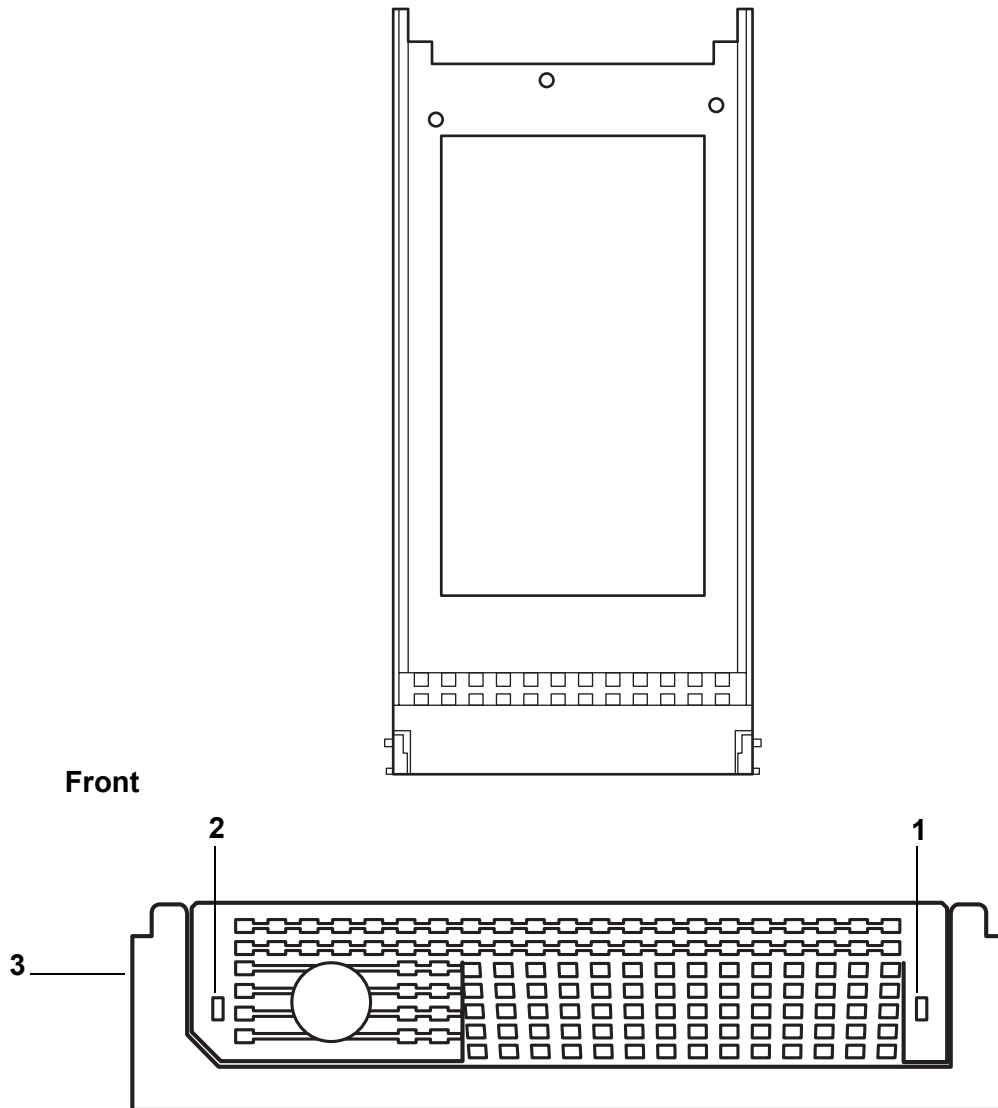

No.	Name	Description
1	Power/Error indicator LED	Different colors indicate different disk states: <ul style="list-style-type: none"> <li>• Green – Disk online</li> <li>• Orange – Disk fail</li> <li>• Red – No disk</li> </ul>
2	Access indicator LED	This blue LED indicates that the disk is being accessed.
3	Tray handle	Releases the disk tray.



## SA-6651E Rear View

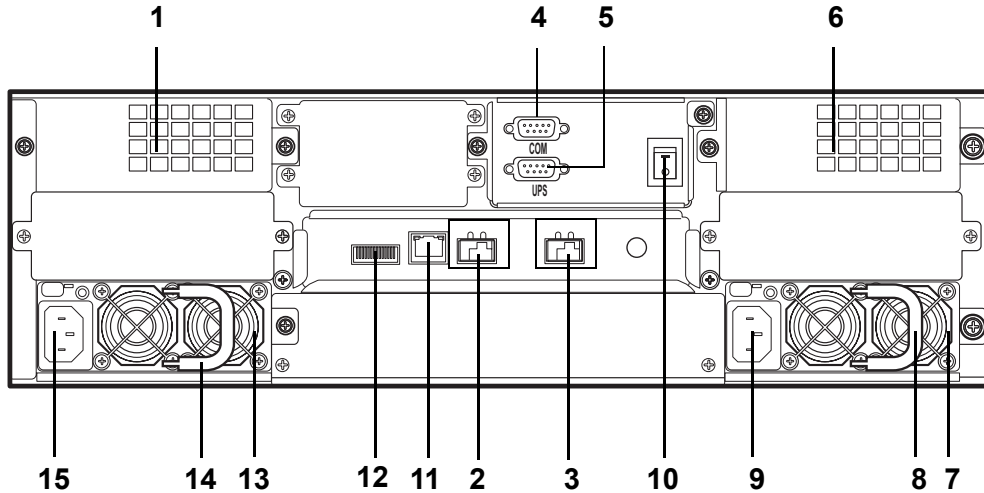

No.	Name	Description
1	Cooling fan 1	System cooling fan.
2	Host Port 2 (Secondary fibre channel)	Connects to the host server.
3	Host Port 1 (Primary fibre channel)	Connects to the host server.
4	RS-232 Port	Connects to a VT100 terminal or equivalent.
5	UPS port	Data port for uninterruptable power supply.
6	Cooling fan 2	System cooling fan.
7	Power Supply 2	Removable redundant power supply 2.
8	Power Supply Handle	For power supply removal.
9	Power Supply AC In	Connects to a 100-240 VAC power source.
10	Power Supply Switch	Switches the power on or off.
11	Ethernet Port	Used for browser-based configuration.
12	Expansion Port	Used for JBOD expansion.
13	Power Supply 1	Removable redundant power supply 1.
14	Power Supply Handle	For power supply removal.
15	Power Supply AC In	Connects to a 100-240 VAC power source.

# Installing Disks

This section describes how to install disks in the disk array system.

- 1 Unlock the front panel door, then pull it open.

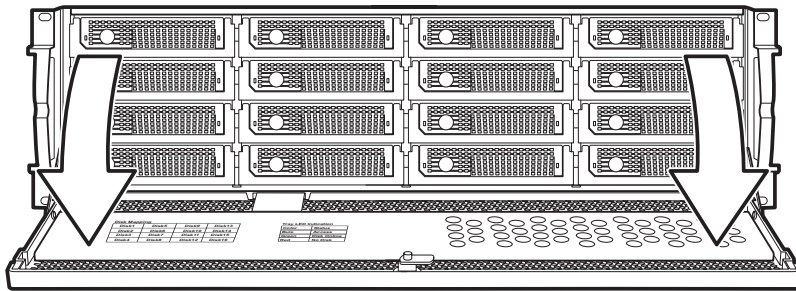

- 2 Push the button **(A)** to release the disk tray handle. Pull the handle **(B)** to release the tray.

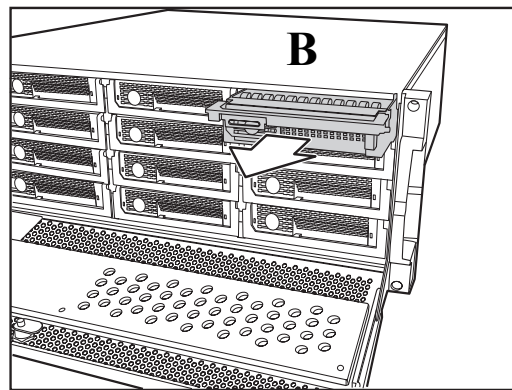
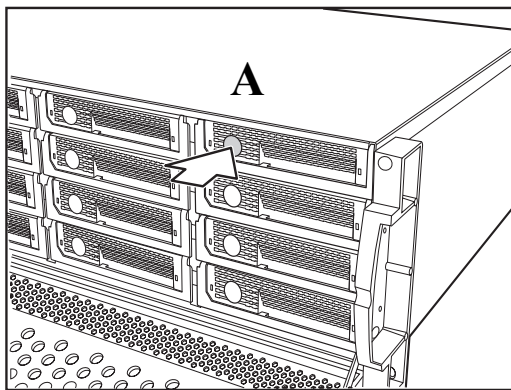

- 3 Align the rear of the disk with the rear of the disk tray.
- 4 Insert the disk into the disk tray and fix into place with screws supplied with the disk.

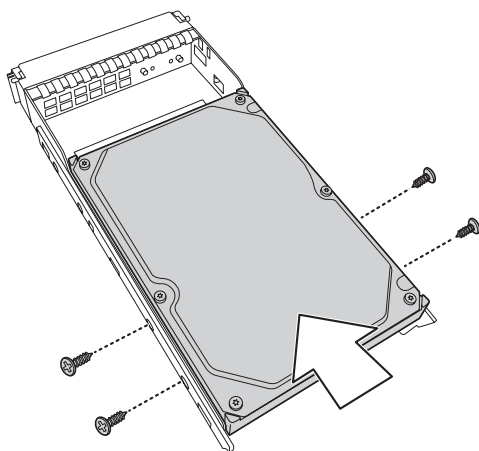

- Slide the disk tray back into the empty slot (A), then slowly close the disk tray handle (B).

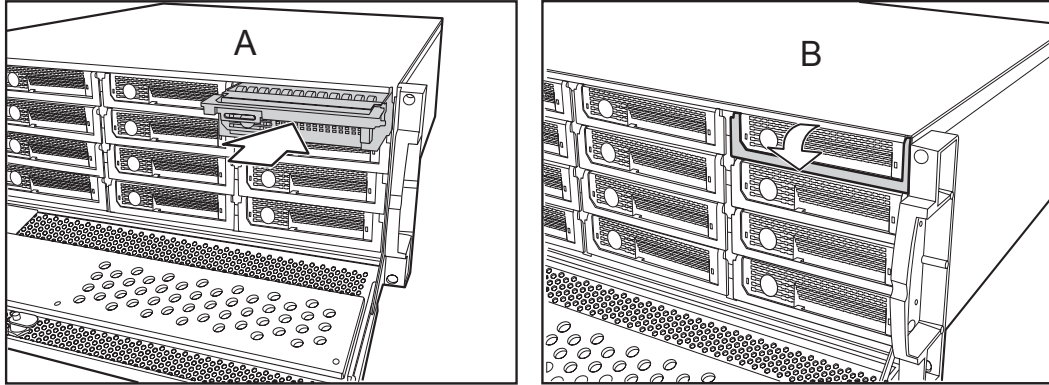

- Repeat steps 2 to 5 until all of the required disks have been installed.
- Push the front panel door closed, and lock it.

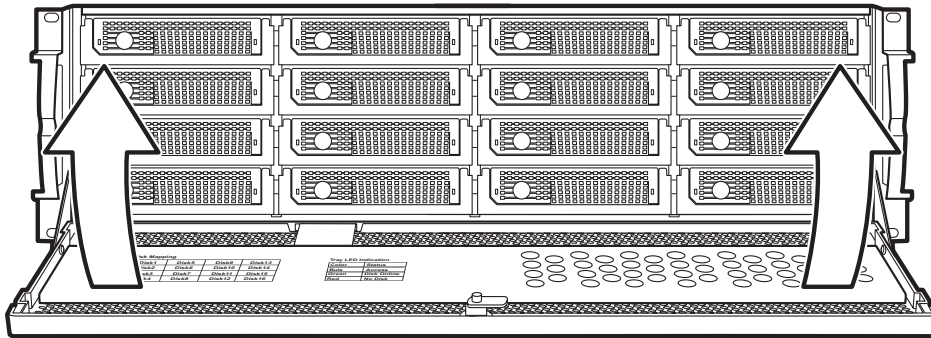

# Making Connections

After the required number of disks have been installed, external connections to the disk array system must be made. This section describes how to make all of the necessary connections.

## Connecting the Host Interface

The disk array system has dual fibre channel interfaces. Refer to the following sections to make host interface connections.

The SA-6651E has dual 4 Gbit fibre channel interfaces. Each interface can be used with optical or copper transceivers and cables. Follow these instructions to make optical connections.

- 1 Insert the LC Optical SFP transceiver (**A**) in to the SA-6651E FC CH 2 (secondary fibre channel) at the rear of the disk array system.
- 2 Connect the optical cable (**B**) to the LC Optical SFP transceiver (**A**).

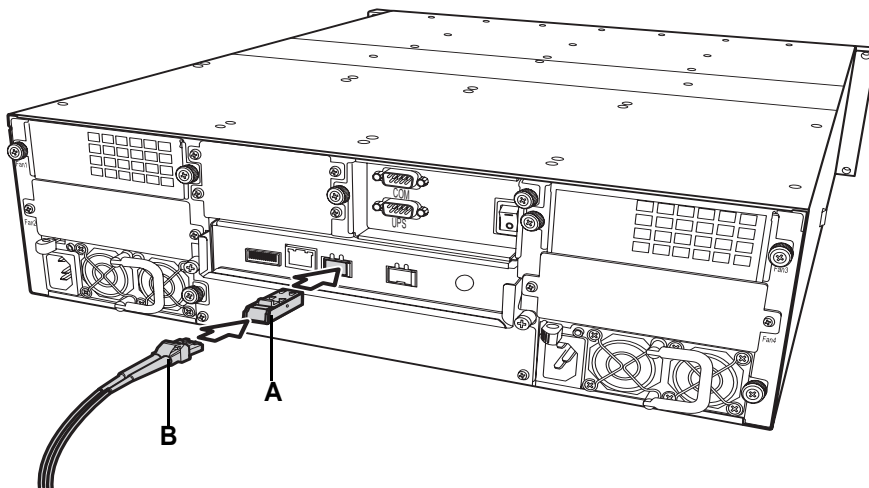

## Connecting the GUI management port

Connecting the GUI management port by a Ethernet cable (standard RJ45) to LAN/WAN environment, and open a web-browser with SA-6651E IP address (Default is 192.168.0.1 and DHCP exabled) for easily monitoring/configuring RAID system.

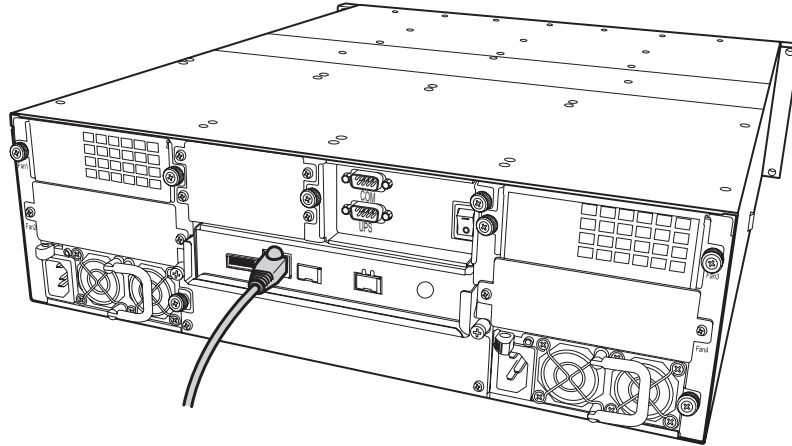

## Connecting the JBOD enclosure

Connect a SAS (SFF-8088, miniSAS connector) external cable to JBOD enclosure.

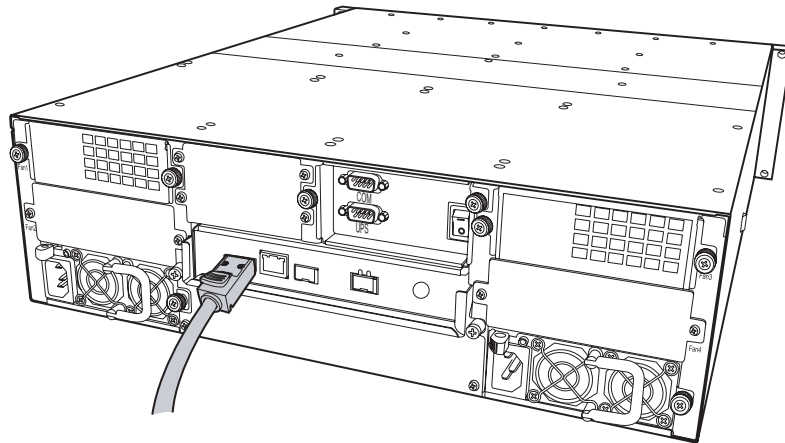

## Connecting and Turning on the Power

- 1 Plug a power cable (A) to a power connector at the rear of the unit, then plug the second power supply cable into the second power connector (B).



---

### Note

The system is equipped with auto switching power supplies that can run on 100 to 240 VAC.

---

- 2 Switch on both power supply switch (C).

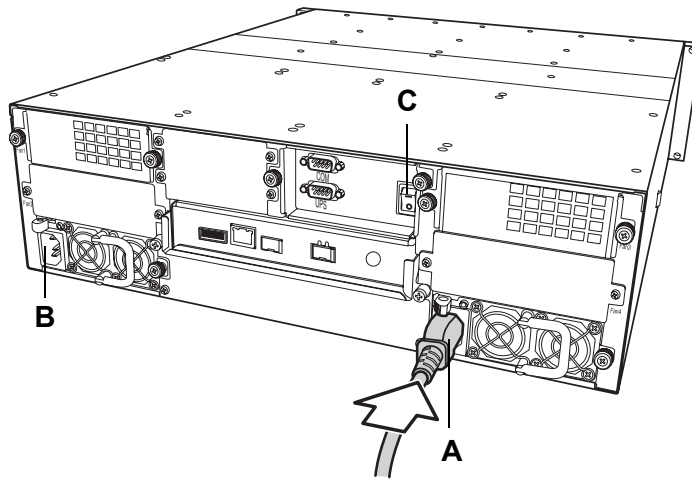

# Mounting in a Rack

When the disk array system is completely set up, it can be installed in a standard 19-inch rack. Follow the instructions in this section to install the disk array system in a rack.

- 1 Clip eight rack nuts supplied with your rack, into the rack, taking care that they correspond with the mounting points on the rails.
- 2 Extend both of the rails so that they are the right length to fit in your rack.
- 3 Bolt the rails into the rack using the rack bolts supplied with your rack.

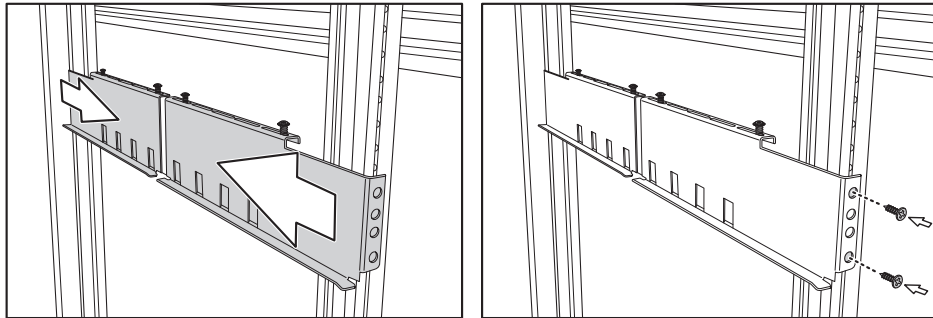

You will need four nuts and bolts (not included) for each rail; two at the front and two at the back.

- 4 Tighten the locking screws when they are the correct length.
- 5 Slide the disk array system into the rack and bolt it into place with the supplied fixing screws.

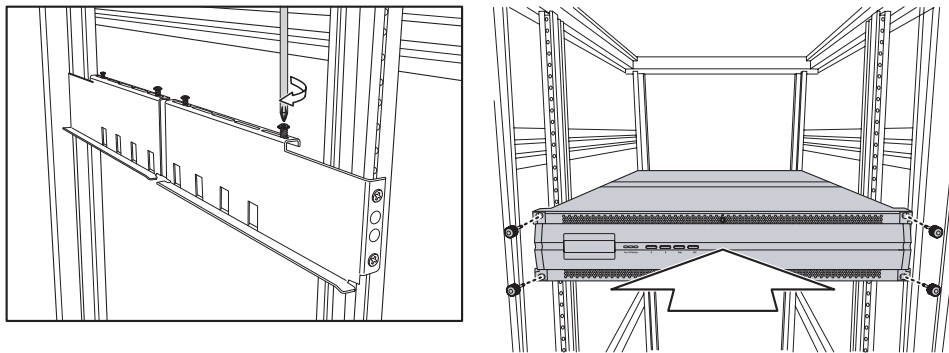

## Caution



This product is heavy. Attempting to install the disk array system in a rack by yourself could result in injury or damage to the product.

## Installing the Rail Extenders

Follow these instructions to fit the rail extenders if required.

- 1 If required, bolt the rail extenders into place as shown using the small bolts provided.
- 2 Slide the disk array system into the rack and bolt it into place with the supplied fixing screws.

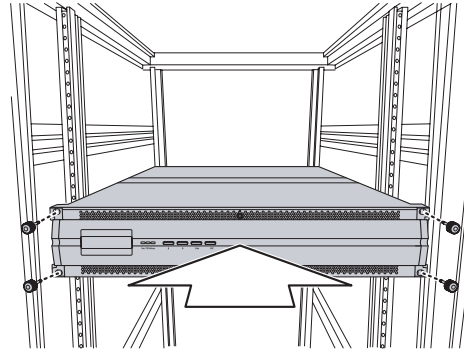
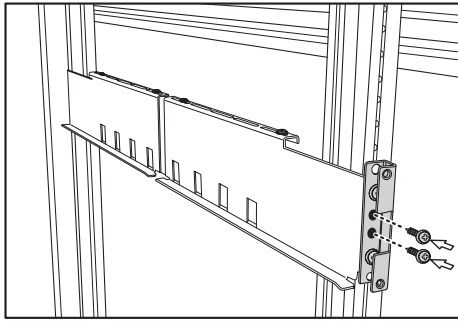

---

### Note

The rail extenders may be required to allow the disk array system room for the front door to open correctly.

---



# 3 Maintenance

## Replacing a Disk

A disk failure is indicated when the Power/Error LED at the front of the drive tray turns red and the audible alert sounds.



### Note

Turn off the audible alert by pressing the Up ↑ and Down ↓ function buttons on the front panel twice simultaneously.

The LCD panel displays the failure with the symbol “R” or “W”. “R” indicates a disk failure or error, and “W” indicates that there are too many bad sectors on the disk.

### Example:

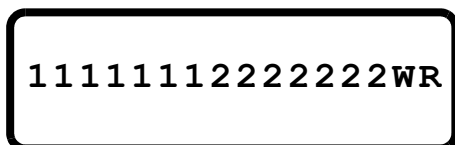

- Disks 1 to 7 are members of array group 1.
- Disks 8 to 14 are members of array group 2.
- Disk 15 has too many bad sectors.
- Disk 16 has an error or a fault.

Disks are hot swappable, which means that they can be inserted and removed while the disk array system is powered on and operating. Follow these instructions to replace a failed disk.

- 1 Unlock the front panel door, then pull it open.
- 2 Pull the tray handle away from the disk tray to release it; and pull the disk tray out.
- 3 Remove the screws from the failed disk, then remove the disk from the disk tray.
- 4 Align the rear of the new disk with the rear of the disk tray.
- 5 Insert the new disk into the disk tray.



### Note

The new disk must have the same or a greater capacity than the faulty disk that was removed. If the disk capacity is smaller, the audible alert sounds and the auto-rebuild operation doesn't start. For best performance, it is recommended that the new disk be identical to the failed disk.

- 6 Attach the disk to the disk tray with the screws that came with the disk.
- 7 Slide the disk tray back into the empty slot, then close the disk tray handle.
- 8 Push the front panel door closed, and lock it.

# Replacing a Power Supply

The disk array system is equipped with a Power Supply Fail Indicator LED at the front of the unit that turns red when one of the power supplies fails. The message “Power x failure” also appears on the LCD panel, where x refers to power supply 1, or 2, and an audible alert sounds.



## Note

Turn off the audible alert by pressing the Up ↑ and Down ↓ function buttons on the front panel twice simultaneously.

Power supplies are hot swappable, which means that they can be inserted and removed while the disk array is powered on and operating. Follow these instructions to replace a failed power supply.

- 1 Identify the power supply that has failed.
- 2 Remove the power cable from the power supply connector at the rear of the unit.
- 3 Loosen the power supply retaining screw.

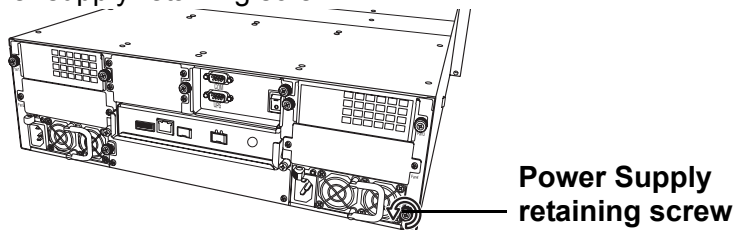

- 4 Remove the faulty power supply by pulling the power supply handle **A** and pressing the release catch **B** at the same time.

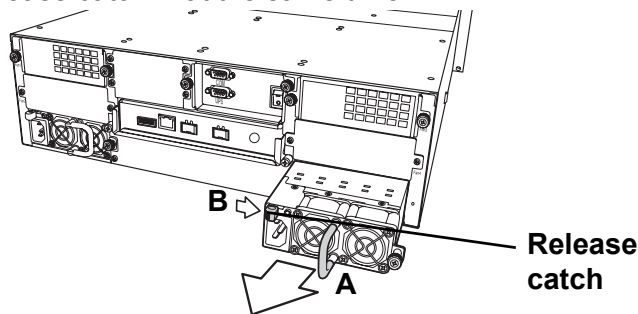

- 5 Insert a new power supply.
- 6 Tighten the power supply retaining screw.

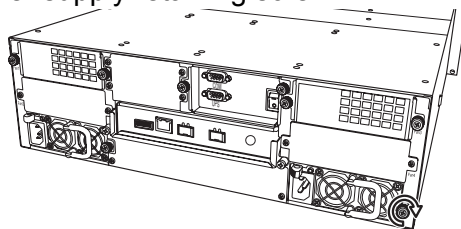

- 7 Reconnect the power cable.

# Upgrading Memory

The disk array system takes a single DDRII DIMM with a maximum capacity of 2 GB. Follow these instructions to upgrade the memory.

- 1 Loosen the screws holding the controller cage in place, slide the controller-cage out of the chassis.
- 2 Pull the DIMM retaining clips away from the DIMM; the DIMM springs out of the socket. Remove the DIMM.

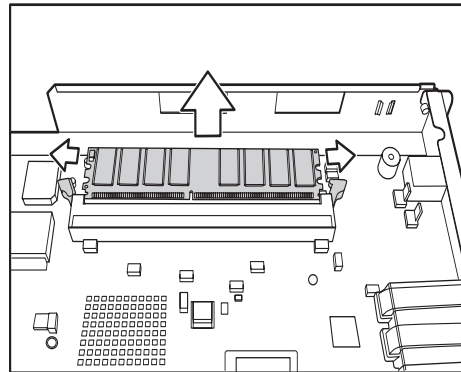
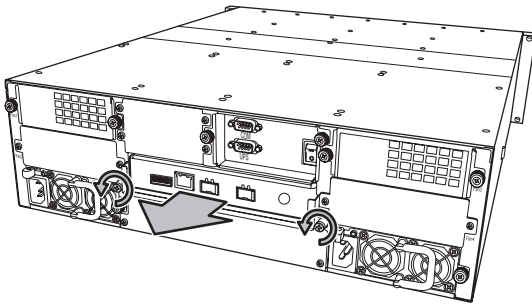

- 3 Gently push the new DIMM into the socket, then push the corners of the DIMM down. The DIMM is secured by the DIMM retaining clips. Push the controller cage back in, lower the handle, and tighten the retaining screws.



## Note

The DIMM module will fit in only one direction. Do not force the DIMM into place.

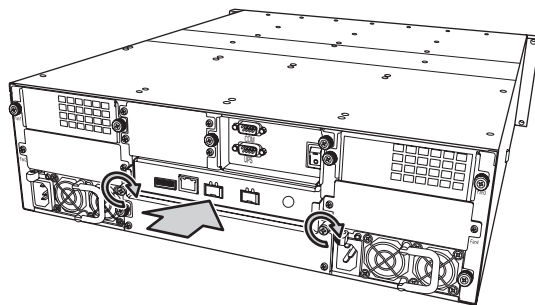
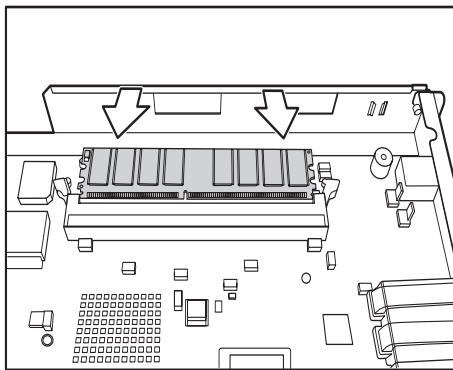

# Replacing a FAN module

When one of the FAN module fails, the message “FANx Fail” appears on the LCD panel, where x refers to power supply 1, or 2, and an audible alert sounds.



## Note

Turn off the audible alert by pressing the Up and Down function buttons on the front panel twice simultaneously.

- 1 Identify the FAN module that has failed, loosen the retaining screws, slide it out of chassis.

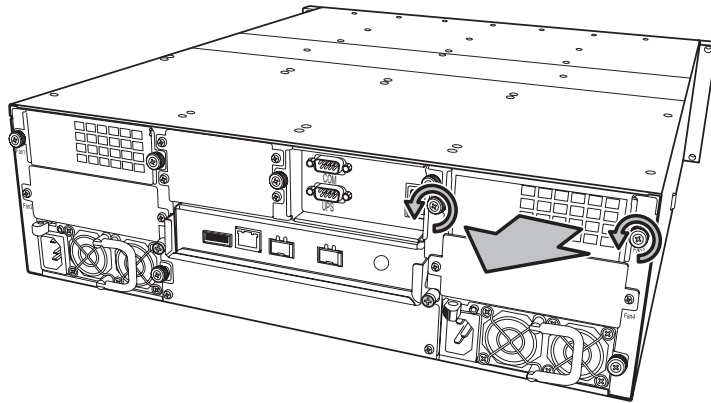

- 2 Insert a new FAN module, tighten retaining screws.

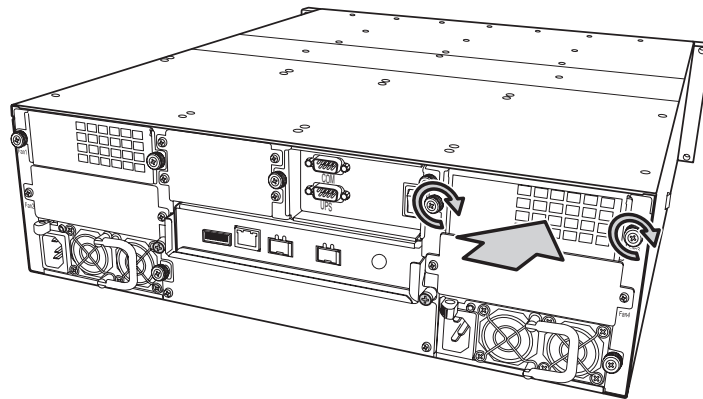

# Appendix

## Hardware Specifications

Item	Specification
CPU	AMCC PPC 440SP
Memory	DDRII 240pin DIMM (ECC support)
Host Interface	4 Gb Fibre Channel x 2
Disk Interface	3 Gb SATA x 16
Temperature Sensor	<ul style="list-style-type: none"><li>• 3 on controller</li><li>• 7 on backplane</li></ul>
Dimensions	132 mm (H) x 485 mm (W) x 574 mm (D)
Weight	24 Kg without disks
Management IO connector	<ul style="list-style-type: none"><li>• 1 x RS-232 COM port</li><li>• 1 x RJ-45 LAN port (10/100 Mbps)</li></ul>
JBOD Expansion	Yes (optional)
Battery Backup Module	Yes (optional)
FAN	<ul style="list-style-type: none"><li>• Turbine FAN x 2</li><li>• Hot Swapable</li></ul>
Power Supply	<ul style="list-style-type: none"><li>• Redundant 1 + 1, 460 Watt</li><li>• 100 - 240 VAC, 47-63 Hz, 6~3A +/- 10%</li><li>• Over voltage, current, power, and short circuit protection</li><li>• LED indicates power status</li><li>• Output: +5V, +3.3V, +12V</li></ul>
Operating Environment	<ul style="list-style-type: none"><li>• Temperature : 5°C ~ 40°C</li><li>• Humidity: 10 ~ 85% (non condensing)</li></ul>
Warranty	3 year warranty
Safety	UL, CUL, CB
EMC	FCC, CE, C-Tick, BSMI

