

INSTRUCTIONS-PARTS LIST

307-724

Rev H

This manual contains **IMPORTANT WARNINGS and INFORMATION**
READ AND RETAIN FOR REFERENCE

Supersedes Rev F
(and Rev G – not published)

EM 390® PORTABLE/ELECTRIC AIRLESS PAINT SPRAYER

2500 psi (172 bar) MAXIMUM WORKING PRESSURE

U.S. Patent No. 4,323,741

Upright Carts

Model 231-001, Series B

Basic sprayer, without hose or gun

Model 231-390

Complete sprayer with hose, "Flex" gun, Reverse-A-Clean IV® DripLess® Tip Guard, and 517 size SwitchTip®, and is CSA listed



Model 231-018

Same as Model 231-390 except has "Contractor" gun

Lo-Boy Carts

Model 220-726, Series C

Basic sprayer, without hose or gun

Model 231-051

Complete sprayer with hose, "Flex" gun, Reverse-A-Clean IV® DripLess® Tip Guard, and 517 size SwitchTip®, and is CSA listed

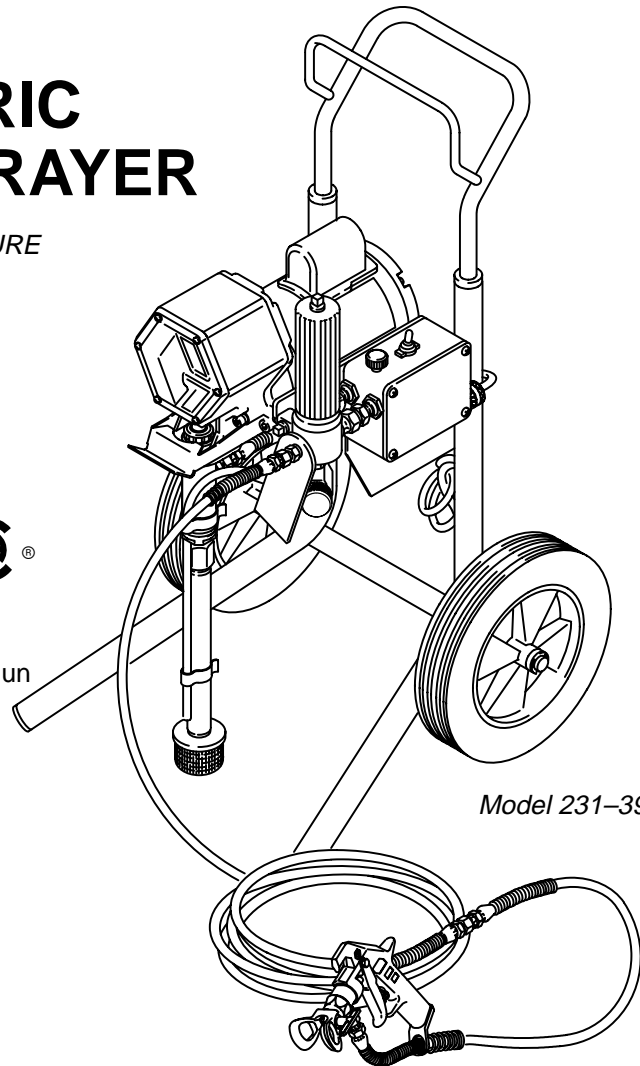

Model 231-390 shown

See Table Of Contents on page 36.

NOTE: This is an example of the DANGER label on your sprayer.
This label is available in other languages, free of charge.
See page 33 to order.

0663

! DANGER !			
	FIRE AND EXPLOSION HAZARD		SKIN INJECTION HAZARD
<p>Spray painting, flushing or cleaning equipment with flammable liquids in confined areas can result in fire or explosion.</p> <p>Use outdoors or in extremely well ventilated areas. Ground equipment, hoses, containers and objects being sprayed.</p> <p>Avoid all ignition sources such as static electricity from plastic drop cloths, open flames such as pilot lights, hot objects such as cigarettes, arcs from connecting or disconnecting power cords or turning light switches on and off.</p> <p>Failure to follow this warning can result in death or serious injury.</p>		<p>Liquids can be injected into the body by high pressure airless spray or leaks – especially hose leaks.</p> <p>Keep body clear of the nozzle. Never stop leaks with any part of the body. Drain all pressure before removing parts. Avoid accidental triggering of gun by always setting safety latch when not spraying.</p> <p>Never spray without a tip guard.</p> <p>In case of accidental skin injection, seek immediate "Surgical Treatment".</p> <p>Failure to follow this warning can result in amputation or serious injury.</p>	
READ AND UNDERSTAND ALL LABELS AND INSTRUCTION MANUALS BEFORE USE			

GRACO INC. P.O. BOX 1441 MINNEAPOLIS, MN 55440-1441

©COPYRIGHT 1985, GRACO INC.

WARNINGS

HIGH PRESSURE SPRAY CAN CAUSE SERIOUS INJURY. FOR PROFESSIONAL USE ONLY. OBSERVE ALL WARNINGS.

Read and understand all instruction manuals before operating the equipment.

FLUID INJECTION HAZARD

General Safety

This equipment generates very high fluid pressure. Spray from the gun, leaks or ruptured components can inject fluid through your skin and into your body, and cause extremely serious bodily injury, including the need for amputation. Also, fluid injected or splashed into the eyes or on the skin can cause serious damage.

NEVER point the spray gun at any one or at any part of the body. NEVER put your hand or fingers over the spray tip. NEVER try to “blow back” paint; this is NOT an air spray system.

ALWAYS have the tip guard in place on the spray gun when spraying.

ALWAYS follow the **PRESSURE RELIEF PROCEDURE**, below, before cleaning or removing the spray tip or servicing any system equipment.

NEVER try to stop or deflect leaks with your hand or body.

Be sure equipment safety devices are operating properly before each use.

Medical Alert—Airless Spray Wounds

If any fluid appears to penetrate your skin, get **EMERGENCY MEDICAL CARE AT ONCE. DO NOT TREAT AS A SIMPLE CUT.** Tell the doctor exactly what fluid was injected.

Note to Physician: *Injection into the skin is a traumatic injury. It is important to treat the injury surgically as soon as possible. Do not delay treatment to research toxicity. Toxicity is a concern with some exotic coatings injected directly into the blood stream. Consultation with a plastic surgeon or reconstructive hand surgeon may be advisable.*

Spray Gun Safety Devices

Be sure all gun safety devices are operating properly before each use. Do not remove or modify any part of the gun; this can cause a malfunction and result in serious bodily injury.

Safety Latch

Whenever you stop spraying, even for a moment, always set the gun safety latch in the closed or “safe” position, making the gun inoperative. Failure to set the safety latch can result in accidental triggering of the gun.

Diffuser

The gun diffuser breaks up spray and reduces the risk of fluid injection when the tip is not installed. Check the diffuser operation regularly. Follow the **PRESSURE RELIEF PROCEDURE**, below, then remove the spray tip. Aim the gun into a metal pail, holding the gun firmly to the pail. Using the lowest possible pressure, trigger the gun. If the fluid emitted *is not* diffused into an irregular stream, replace the diffuser immediately.

Tip Guard

ALWAYS have the tip guard in place on the spray gun while spraying. The tip guard alerts you to the fluid injection hazard and helps reduce, but does not prevent, the risk of accidentally placing your fingers or any part of your body close to the spray tip.

Trigger Guard

Always have the trigger guard in place on the gun when spraying to reduce the risk of accidentally triggering the gun if it is dropped or bumped.

Spray Tip Safety

Use extreme caution when cleaning or changing spray tips. If the spray tip clogs while spraying, engage the gun safety latch immediately. ALWAYS follow the **PRESSURE RELIEF PROCEDURE**, below, and then remove the spray tip to clean it.

NEVER wipe off build-up around the spray tip until the pressure is fully relieved and the gun safety latch is engaged.

PRESSURE RELIEF PROCEDURE

To reduce the risk of serious bodily injury, including fluid injection, splashing fluid or solvent in the eyes or on the skin, or injury from moving parts or electric shock, always follow this procedure whenever you shut off the sprayer, when checking or servicing any part of the spray system, when installing, cleaning or changing spray tips, and whenever you stop spraying.

1. Engage the gun safety latch.
2. Turn the ON/OFF switch to OFF.
3. Unplug the power supply cord.

4. Disengage the gun safety latch. Hold a metal part of the gun firmly to the side of a grounded metal pail, and trigger the gun to relieve pressure.
5. Engage the gun safety latch.
6. Open the pressure drain valve, having a container ready to catch the drainage. Leave the valve open until you are ready to spray again.

If you suspect that the spray tip or hose is completely clogged, or that pressure has not been fully relieved after following the steps above, VERY SLOWLY loosen the tip guard retaining nut or hose end coupling to relieve pressure gradually, then loosen completely. Now clear the tip or hose obstruction.

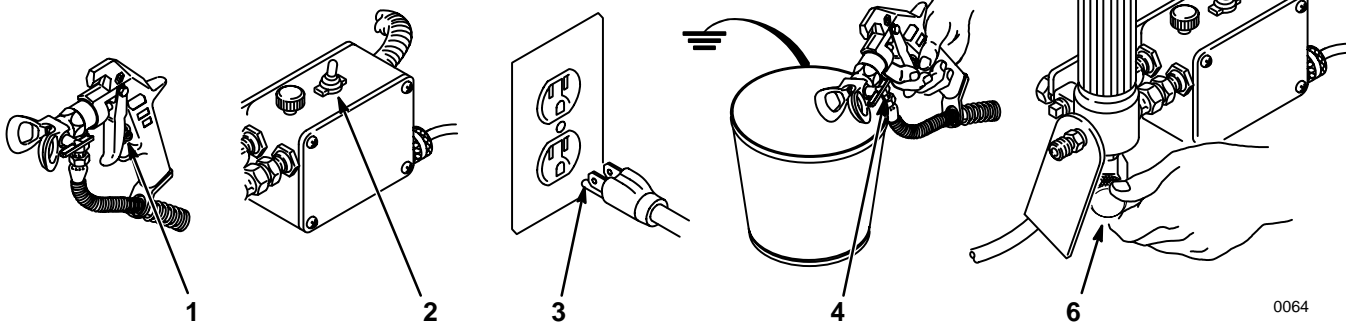

MOVING PARTS HAZARD

Moving parts can pinch or amputate your fingers or other body parts. KEEP CLEAR of moving parts when starting or operating the sprayer. Follow the **Pressure Relief Procedure** on page 2 before checking or servicing any part of the sprayer, to prevent it from starting accidentally.

EQUIPMENT MISUSE HAZARD

General Safety

Any misuse of the spray equipment or accessories, such as overpressurizing, modifying parts, using incompatible chemicals and fluids, or using worn or damaged parts, can cause them to rupture and result in fluid injection, splashing in the eyes or on the skin, or other serious bodily injury, or fire, explosion or property damage.

NEVER alter or modify any part of this equipment; doing so could cause it to malfunction.

CHECK all spray equipment regularly and repair or replace worn or damaged parts immediately.

Always wear protective eyewear, gloves, clothing and respirator as recommended by the fluid and solvent manufacturer.

System Pressure

This sprayer can develop 2500 psi (172 bar) **MAXIMUM WORKING PRESSURE**. Be sure all spray equipment and accessories used are rated to withstand this pressure. DO NOT exceed the maximum working pressure of any component or accessory used in the system.

Fluid and Solvent Compatibility

All chemicals used in the sprayer must be chemically compatible with the wetted parts shown in the **TECHNICAL DATA** on page 34. Consult your chemical supplier to ensure compatibility.

Do not use 1,1,1-trichloroethane, methylene chloride, other halogenated hydrocarbon solvents or fluids containing such solvents in this equipment, which contains aluminum and/or zinc parts. Such use could result in a serious chemical reaction, with the possibility of explosion, which could cause death, serious bodily injury and/or substantial property damage.

FIRE OR EXPLOSION HAZARD

Static electricity is created by the flow of fluid through the pump and hose. If every part of the spray equipment is not properly grounded, sparking may occur, and the system may become hazardous. Sparking may also occur when plugging in or unplugging a power supply cord or using a gasoline engine. Sparks can ignite fumes from solvents and the fluid being sprayed, dust particles and other flammable substances, whether you are spraying indoors or outdoors, and can cause a fire or explosion and serious bodily injury and property damage. Always plug the sprayer into an outlet at least 20 feet (6 m) away from the sprayer and the spray area. Do not plug in or unplug any power supply cords in the spray area when there is any chance of igniting fumes still in the air.

If you experience any static sparking or even a slight shock while using this equipment, **STOP SPRAYING IMMEDIATELY**. Check the entire system for proper grounding. Do not use the system again until the problem has been identified and corrected.

Grounding

To reduce the risk of static sparking, ground the sprayer and all other spray equipment used or located in the spray area. CHECK your local electrical code for detailed grounding instructions for your area and type of equipment. BE SURE to ground all of this spray equipment:

1. *Sprayer*: plug the power supply cord, or extension cord – each equipped with an undamaged, three-prong plug, into a properly grounded outlet. Do not use an adapter. All extension cords must have three wires and be rated for 15 Amps.

HOSE SAFETY

High pressure fluid in the hoses can be very dangerous. If the hose develops a leak, split or rupture due to any kind of wear, damage or misuse, the high pressure spray emitted from it can cause a fluid injection injury or other serious bodily injury or property damage.

ALL FLUID HOSES MUST HAVE STRAIN RELIEFS ON BOTH ENDS! The strain reliefs help protect the hose from kinks or bends at or close to the coupling which can result in hose rupture.

TIGHTEN all fluid connections securely before each use. High pressure fluid can dislodge a loose coupling or allow high pressure spray to be emitted from the coupling.

NEVER use a damaged hose. Before each use, check the entire hose for cuts, leaks, abrasion, bulging cover, or damage or movement of the hose couplings. If any of these conditions exist, replace the hose immediately. DO NOT try to recouple high pressure hose or mend it with tape or any other device. A repaired hose cannot contain the high pressure fluid.

HANDLE AND ROUTE HOSES CAREFULLY. Do not pull on hoses to move equipment. Keep hoses clear of moving parts and hot surfaces of the pump. Do not use fluids or solvents which are not compatible with the inner tube and cover of the hose. DO NOT expose Graco hoses to temperatures above 180° F (82° C) or below -40° F (-40° C).

Hose Grounding Continuity

Proper hose grounding continuity is essential to maintaining a grounded spray system. Check the electrical resistance of your fluid hoses at least once a week. If your hose does not have a tag on it which specifies the maximum electrical resistance, contact the hose supplier or manufacturer for the maximum resistance limits. Use a resistance meter in the appropriate range for your hose to check the resistance. If the resistance exceeds the recommended limits, replace it immediately. An ungrounded or poorly grounded hose can make your system hazardous. Also read **FIRE OR EXPLOSION HAZARD**, below.

2. *Fluid hoses*: use only grounded hoses with a maximum of 500 ft. (150 m) combined hose length to ensure grounding continuity. See **Hose Grounding Continuity** on page 3.
3. *Spray gun*: obtain grounding through connection to a properly grounded fluid hose and sprayer.
4. *Object being sprayed*: according to local code.
5. *Fluid supply container*: according to local code.
6. *All solvent pails used when flushing*, according to local code. Use only metal pails, which are conductive. Do not place the pail on a non-conductive surface, such as paper or cardboard, which interrupts the grounding continuity.
7. *To maintain grounding continuity when flushing or relieving pressure*, always hold a metal part of the gun firmly to the side of a grounded metal pail, then trigger the gun.

Flushing Safety

Reduce the risk of fluid injection injury, static sparking, or splashing by following the flushing procedure given on page 13 of this manual. Follow the **PRESSURE RELIEF PROCEDURE** on page 2, and remove the spray tip before flushing. Hold a metal part of the gun firmly to the side of a grounded metal pail and use the lowest possible fluid pressure during flushing.

IMPORTANT

United States Government safety standards have been adopted under the Occupational Safety and Health Act. These standards – particularly the General Standards, Part 1910, and the Construction Standards, Part 1926 – should be consulted.

AVERTISSEMENT

La pulvérisation à haute pression peut causer de blessures très graves.
Réservé exclusivement à l'usage professionnel. Observer toutes les consignes de sécurité.
Bien lire et bien comprendre tous les manuels d'instructions avant d'utiliser le matériel.

RISQUES D'INJECTION

Consignes générales de sécurité

Cet appareil produit un fluide à très haute pression. Le fluide pulvérisé par le pistolet ou le fluide sous pression provenant de fuites ou de ruptures peut pénétrer sous la peau ou à l'intérieur du corps et entraîner des blessures très graves, voir même une amputation. Même sans être sous pression, le fluide éclaboussant ou entrant dans les yeux peut aussi entraîner des blessures graves.

NE JAMAIS pointer le pistolet vers quelqu'un ou vers une partie quelconque du corps. NE JAMAIS mettre la main ou les doigts sur l'ajutage du pulvérisateur. NE JAMAIS essayer de "refouler" la peinture. Cet appareil n'est PAS un compresseur pneumatique.

TOUJOURS garder la protection de l'ajutage en place sur le pistolet pendant la pulvérisation.

TOUJOURS observer la **Marche à Suivre Pour Détendre la Pression** donnée plus loin, avant de nettoyer ou d'enlever l'ajutage du pulvérisateur, ou d'effectuer un travail quelconque sur une partie de l'appareil.

NE JAMAIS essayer d'arrêter ou de dévier les fuites avec la main ou le corps.

Avant chaque utilisation, bien s'assurer que les dispositifs de sécurité fonctionnent correctement.

Soins médicaux

En cas de pénétration de fluide sous la peau: **DEMANDER IMMEDIATEMENT DES SOINS MÉDICAUX D'URGENCE. NE PAS SOIGNER CETTE BLESSURE COMME UNE SIMPLE COUPURE.**

***Avis au médecin:** La pénétration des fluides sous la peau est un traumatisme. Il est important de traiter chirurgicalement cette blessure immédiatement. Ne pas retarder le traitement pour effectuer des recherches sur la toxicité. Certains revêtements exotiques sont dangereusement toxiques quand ils sont injectés directement dans le sang. Il est souhaitable de consulter un chirurgien esthétiques ou un chirurgien spécialisé dans la reconstruction des mains.*

Dispositifs de sécurité du pistolet

Avant chaque utilisation, bien s'assurer que tous les dispositifs de sécurité du pistolet fonctionnent correctement. Ne pas enlever ni modifier une partie quelconque du pistolet; ceci risquerait d'entraîner un mauvais fonctionnement et des blessures graves.

MARCHE À SUIVRE POUR DÉTENDRE LA PRESSIION

Pour réduire les risques de blessures graves, y compris les blessures par projection de fluide ou celles causées par de éclaboussures dans les yeux ou sur la peau, par des pièces en mouvement, toujours bien observe cette marche à suivre chaque fois que l'on arrête le pulvérisateur, à l'occasion de la vérification, du Égale ou du nettoyage du système ou lors du changement des ajutages.

1. Engager le verrou de sécurité du pistolet.
2. Mettre le levier d'arrêt du moteur sur ARRÊT (OFF).
3. Débrancher le cord d'alimentation.
4. Désengager le verrou de sécurité du pistolet. Tout en mainte-

Verrou de sécurité

A chaque fois que l'on s'arrête de pulvériser, même s'il s'agit d'un court instant, toujours mettre le verrou de sécurité du pistolet sur la position, "fermée" ou "sécurité" ("safe"), pour empêcher le pistolet de fonctionner. Si le verrou de sécurité n'est pas mis, le pistolet peut se déclencher accidentellement.

Diffuseur

Le diffuseur du pistolet sert à diviser le jet et à réduire les risques d'injection accidentelle quand l'ajutage n'est pas en place. Vérifier le fonctionnement du diffuseur régulièrement. Pour cette vérification, détendre la pression en observant la **Marche à Suivre Pour Détendre la Pression** donnée plus loin enlever l'ajutage du pulvérisateur. Pointer le pistolet dans un seau en métal, en le maintenant fermement contre le seau. Puis, en utilisant la pression la plus faible possible, appuyer sur la gâchette du pistolet. Si le fluide projeté n'est pas diffusé sous forme de jet irrégulier, remplacer immédiatement le diffuseur.

Protection de l'ajutage

TOUJOURS maintenir la protection de l'ajutage en place sur le pistolet du pulvérisateur pendant la pulvérisation. La protection de l'ajutage attire l'attention sur les risques d'injection et contribue à réduire, mais n'évite pas le risque, que les doigts ou une partie quelconque du corps ne passent accidentellement à proximité immédiate de l'ajutage du pulvérisateur.

Consignes de sécurité concernant l'ajutage du pulvérisateur

Faire extrêmement attention à l'occasion du nettoyage ou du remplacement des ajutages du pulvérisateur. Si l'ajutage se bouche pendant la pulvérisation, mettre immédiatement le verrou de sécurité du pistolet. TOUJOURS bien observe la **Marche à Suivre Pour Détendre la Pression** puis enlever l'ajutage du pulvérisateur pour le nettoyer.

NE JAMAIS essayer ce qui s'est accumulé autour de l'ajutage du pulvérisateur avant que la pression ne soit complètement tombée et que le verrou de sécurité du pistolet ne soit engagé.

nant une partie métallique du pistolet fermement appuyé contre le côté d'un seau en métal, actionner le pistolet pour libérer la pression.

5. Engager le verrou de sécurité du pistolet.
6. Ouvrir la soupape de sécurité et la laisser ouverte jusqu'à ce que l'on soit prêt à se servir de nouveau du pulvérisateur.

Si l'on soupçonne que le tuyau ou l'ajutage est complètement bouché ou que la pression n'a pas été complètement libérée après avoir procédé aux opérations ci-dessus, desserrer TRES LENTEMENT un raccord de bout de tuyau ou l'écrou de retenue de la protection de l'ajutage et libérer progressivement la pression.

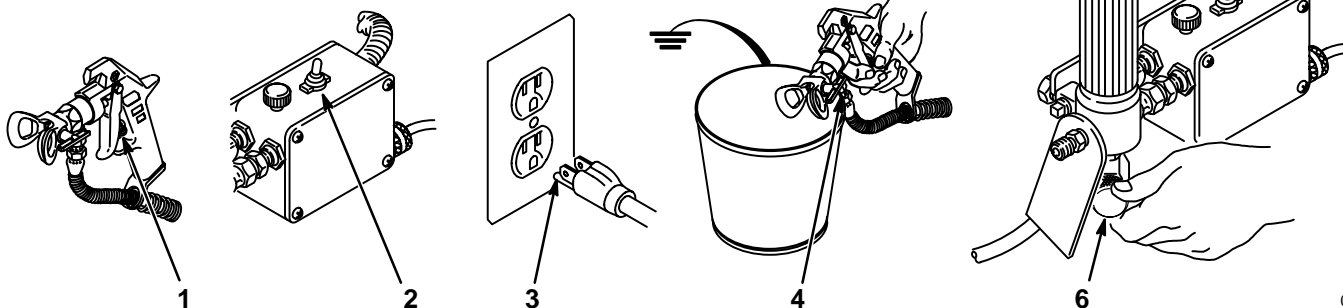

RISQUES EN CAS DE MAUVAISE UTILISATION DU MATERIAL

Consignes générales de sécurité

Toute utilisation anormale de l'appareil de pulvérisation ou des accessoires comme, par exemple, la mise sous une pression excessive, les modifications de pièces, l'utilisation de produits chimiques et de matières incompatibles et l'utilisation de pièces usées ou abîmées peut causer des dégâts à l'appareil ou des ruptures de pièces et entraîner une injection de liquide ou d'autres blessures sérieuses, un incendie, une explosion ou d'autres dégâts.

Toujours porter une protection pour les yeux, de gants, des vêtements protecteur et un dispositif pour la respiration correspondant aux recommandations des fabricants de fluides et solvants.

Pression

Ce pulvérisateur peut produire une **PRESSION MAXIMUM DE TRAVAIL 172 bar (2500 lb/po.²)**. S'assurer que tous les éléments du pulvérisateur et ses accessoires sont conçus pour résister à la pression maximum de travail de ce pulvérisateur. **NE PAS** dépasser la pression maximum de travail d'aucun des éléments ou accessoires utilisés avec cet appareil.

Compatibilité chimique des corps

BIEN S'ASSURER que tous les corps des solvants utilisés sont chimiquement compatibles avec les parties mouillées indiquées dans les "Données techniques", à page 34. Toujours lire soigneusement les documents et brochures du fabricant des fluides et solvants utilisés avant de s'en servir dans ce pulvérisateur.

Le fluide à haute pression circulant dans les tuyaux peut être très dangereux. En cas de fuite sur le tuyau, de fissure, déchirure ou rupture à la suite de l'usure, de dégâts ou d'une mauvaise utilisation, les projections de fluide haute pression qui en proviennent peuvent entraîner des blessures graves par pénétration sous la peau ou par contact, ainsi que des dégâts matériels.

RISQUES D'INCENDIE OU D'EXPLOSION

De l'électricité statique est produite par le passage du fluide à grande vitesse dans la pompe et dans les tuyaux. Si toutes les pièces de l'appareil de pulvérisation ne sont pas convenablement reliées ou à la masse ou à la terre, des étincelles peuvent se produire et l'appareil risque d'être dangereux. Des étincelles peuvent également se produire à l'occasion du branchement ou du débranchement du cordon d'alimentation ou de l'utilisation d'un moteur à essence. Les étincelles sont suffisantes pour allumer les vapeurs de solvants et le fluide pulvérisé, les fines particules de poussière ainsi que d'autres substances inflammables, quand on pulvérise à l'intérieur ou à l'extérieur, et elles peuvent causer un incendie ou une explosion, ainsi que des blessures graves et des dégâts matériels. Toujours brancher le pulvérisateur dans une prise se trouvant à au moins 6 m (20 pieds) de l'appareil et de l'endroit où se fait la pulvérisation. Ne pas brancher ou débrancher un cordon d'alimentation quel qu'il soit dans la zone où se fait la pulvérisation quand il y a le moindre risque que des vapeurs encore présentes dans l'air prennent feu.

S'il se produit des étincelles d'électricité statique, ou si vous ressentez la moindre décharge, **ARRETEZ IMMEDIATEMENT LA PULVERISATION**. Vérifiez que le système avant que le problème soit identifié et corrigé.

Mise à la terre ou à la masse

Pour réduire les risques de production d'étincelles d'électricité statique, le pulvérisateur et tous les équipements utilisés ou se trouvant dans la zone de pulvérisation doivent être reliés à la terre ou à la masse. Pour connaître le détail des instructions de mise à la terre dans la région et le type particulier d'équipement, **CONSULTER** le code ou les réglementations électriques locales. **S'ASSURER** que tous les équipements de pulvérisation suivants sont bien reliés à la terre:

TOUS LES TUYAUX FLEXIBLES DOIVENT AVOIR DES RESORTS SPIRALE DE PROTECTION AUX 2 BOUTS! Les spirales de protection contribuent à éviter la formation de plis, de boucles ou de nœuds sur les tuyaux qui pourraient entraîner la rupture du tuyau à l'endroit du raccord ou à son voisinage.

SERRER FERMEMENT tous les raccords avant chaque utilisation. Le fluide sous pression peut faire sauter un raccord desserré ou produire un jet à haute pression s'échappant par le raccord.

NE JAMAIS utiliser un tuyau endommagé. **NE PAS** essayer de refaire le raccord d'un tuyau haute pression ni de réparer le tuyau avec du ruban adhésif ou par tout autre moyen. Un tuyau réparé ne peut pas résister au fluide sous pression.

MANIPULER LES TUYAUX AVEC PRECAUTION ET CHOISIR SOIGNEUSEMENT LEUR CHEMIN. Ne pas déplacer le fluide en tirant sur le tuyau. Ne pas utiliser de fluides ou de solvants qui ne sont pas compatibles avec l'enveloppe intérieur ou extérieur de tuyau. **NE PAS** exposer le tuyau à fluides des températures supérieures à 82°C (180°F) ou inférieures à -40°C (-40°F).

Continuité de la mise à la terre des tuyaux

Une bonne continuité de la mise à la terre des tuyaux est essentielle pour maintenir la mise à la terre de l'ensemble de vaporisation. Vérifiez la résistance électrique de vos tuyaux à fluides et à air, au moins une fois par semaine. Si votre tuyau ne comporte pas d'étiquette qui précise la résistance électrique maximum, prenez contact avec le fournisseur de tuyaux ou le fabricant pour avoir les limites de résistance maximum. Utilisez un mètre de résistance de la gamme appropriée pour votre tuyau et vérifiez la résistance. Si celle-ci dépasse les limites recommandées, remplacez le tuyau immédiatement. Un tuyau sans mise à la terre ou avec une mise à la terre incorrecte peut entraîner des risques pour votre système. Lisez aussi **LES RISQUES D'INCENDIE OU D'EXPLOSION**.

1. *Pulvérisateur*: Brancher le cordon d'alimentation ou la rallonge qui doivent être équipés d'une prise à 3 fiches en bon état, dans une prise de courant convenablement mis à la terre. Ne pas utiliser d'adaptateur. Toutes les rallonges doivent avoir 3 fils et être prévues pour 15 ampères.
2. *Pistolet*: Réaliser la mise à la terre en le raccordant à un tuyau flexible et à un pulvérisateur déjà convenablement reliés à la terre.
3. *Tuyaux flexibles*: Afin d'assurer la continuité de la mise à la terre, n'utiliser que des tuyaux comportant une mise à la terre et ayant une longueur maximum combinée de 150 m (500 pieds). Se reporter également au paragraphe, "**Continuité du circuit de mis à la terre des tuyaux**".
4. *Récipient d'alimentation*: observer le code ou les réglementations locales.
5. *Objets, matériel ou surfaces recevant la pulvérisation*: observer le code ou les réglementations locales.
6. *Tous le seaux de solvant* utilisés pour le rinçage: observer le code ou les réglementations locales. *N'utiliser que des seaux métallique* conducteurs de l'électricité. Ne pas mettre le seau sur une surface non conductrice comme sur du papier ou du carton car cela interromprait la continuité de la mise à la terre.
7. *Pour conserver la continuité de la mise à la terre quand on rince le matériel ou quand on libère la pression*, toujours maintenir une partie métallique du pistolet fermement appuyée contre le côté d'un seau *en métal* puis appuyer sur la détente du pistolet.

Mesures de Sécurité concernant le Rinçage

Pour réduire les risques de blessures par pénétration de la peau et les risques dûs aux étincelles d'électricité statique ou aux éclaboussures, observe la marche à suivre pour le rinçage donnée à la page 13 de ce manuel.

ADVERTENCIA

**EL ROCIADO A ALTA PRESION PUEDE CAUSAR GRAVES LESIONES.
SOLO PARA USO PROFESIONAL. RESPECTE LOS AVISOS DE ADVERTENCIA.**

Lea y entienda todo el manual de instrucciones antes de manejar el equipo.

PELIGRO DE INYECCION DE FLUIDO

Seguridad general

Este equipo general un fluido a una presión muy alta. El rociado de la pistola, los escapes de fluido o roturas de los componentes pueden inyectar fluido en la piel y el cuerpo y causar lesiones extremadamente graves, incluyendo a veces la necesidad de amputación. También, el fluido inyectado o salpicado en los ojos puede causar graves daños.

NUNCA apuntar la pistola hacia alguien o alguna parte del cuerpo. NUNCA colocar la mano o los dedos encima de la boquilla. NUNCA tratar de "hacer retornar la pintura"; este NO es un sistema de rociado de aire.

SIEMPRE tener colocado el protector de la boquilla en la pistola mientras se está pulverizando.

SIEMPRE seguir el **procedimiento de descarga de presión**, dado más abajo, *antes* de limpiar o sacar la boquilla o de dar servicio a cualquier del sistema.

NUNCA tratar de parar o desviar los escapes con la mano o el cuerpo.

Asegurar que todos los aparatos de seguridad del equipo están funcionando bien antes de cada uso.

Tratamiento médico

Si pareciera que un poco de fluido penetró la piel, conseguir **TRATAMIENTO MEDICO DE URGENCIA DE INMEDIATO. NO TRATAR LA HERIDA COMO UN SIMPLE CORTE.** Decir al médico exactamente cua fluido fue.

Aviso al médico: Si se llega a inyectar este fluido en la piel se causa una lesión traumática. Es importante tratar quirúrgicamente la lesión a la brevedad posible. No demorar el tratamiento para investigar la toxicidad. La toxicidad es algo de sumar importancia en algunas pinturas exóticas cuando se inyectan directamente al torrente sanguíneo. Sirá conveniente consultar a un especialista en cirugía plástica o reconstructiva de las manos.

PROCEDIMIENTO DE DESCARGA DE PRESION

Para reducir el riesgo de sufrir graves lesiones corporales, incluyendo la inyección de fluidos, salpicaduras en los ojos o la piel, o lesiones causadas por piezas en movimiento, siempre seguir este procedimiento al apagar la máquina pulverizadora, al revisar, ajustar o limpiar el sistema, o al cambiar las boquillas.

1. Enganchar el pestillo de seguridad de la pistola.
2. Mover el interruptor de parada del motor a OFF.
3. Desenchufar el cordón eléctrico.
4. Desenganchar el pestillo de seguridad de la pistola. Mantener una parte metálica de la pistola firmemente contra el lado de un balde de metal y activar la pistola para descargar la presión.

Aparatos de seguridad de la pistola pulverizadora

Asegurar que todos los aparatos protectores de la pistola están funcionando bien antes de cada uso. No sacar ni modificar ninguna pieza de la pistola pues podría causar el malfuncionamiento de la misma con las consiguientes lesiones personales.

Pestillo de seguridad

Cada vez que se deje de pulverizar, aunque sea por un breve momento, siempre colocar el pestillo de seguridad en la posición "cerrada", lo que deja la pistola inoperante. El no hacerlo puede llevar al disparo imprevisto de la pistola.

Difusor

El difusor de la pistola dispersa el chorro pulverizado y reduce el riesgo de inyección cuando no está instalada la boquilla. Revisar con regularidad el funcionamiento del difusor. Seguir el **procedimiento de descarga de presión**, dado más abajo, y después sacar la boquilla. Apuntar la pistola a un balde metálico, sosteniéndola bien firme contra él. Utilizando la presión más bajo posible, disparar la pistola. Si el fluido emitido *no sale disperso* en un chorro irregular, reemplazar de inmediato el difusor.

Protector de la boquilla

SIEMPRE tener el protector de la boquilla colocado en la pistola mientras se está pulverizando. Este protector llama la atención contra el peligro de inyección y ayuda a reducir, pero no evita, la colocación accidental de los dedos o cualquier otra parte del cuerpo cerca de la boquilla.

Seguridad de la boquilla pulverizadora

Tener mucho cuidado al limpiar o cambiar las boquillas. Si llegara a obstruirse mientras está pulverizando, enganchar el pestillo de la pistola de inmediato. SIEMPRE seguir el **procedimiento de descarga de presión** y después sacar la boquilla para limpiarla

NUNCA limpiar la acumulación de pintura alrededor de la boquilla antes de que se haya descargado por completo la presión y el pestillo esté enganchado.

5. Volver a enganchar el pestillo de seguridad de la pistola.
6. Abrir la válvula de alivio de presión y dejarla abierta hasta que se esté nuevamente listo para pulverizar.

Si se sospecha que la boquilla o la manguera esté completamente obstruida, o que no se ha descargado por completo la presión después de haber seguido el procedimiento anterior, aflojar MUY LENTAMENTE un adaptador de extremo de la manguera o la tuerca de renovación del protector de la punta y descargar gradualmente la presión.

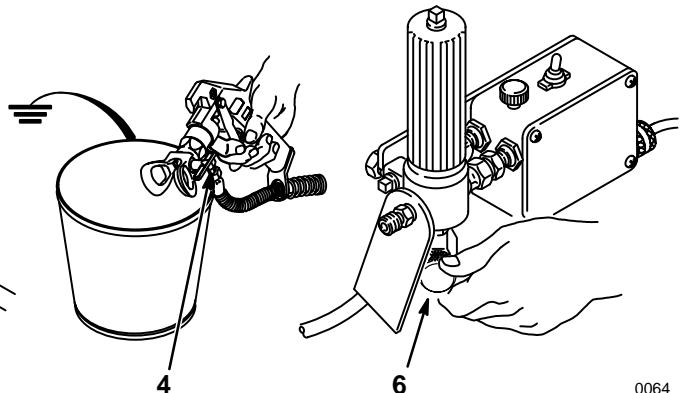
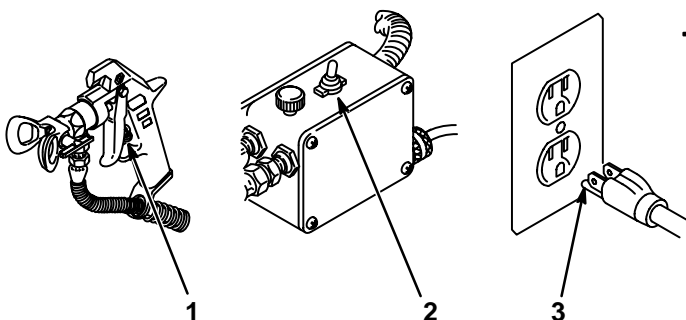

PELIGRO POR MAL USO DEL EQUIPO

Seguridad general

Cualquier mal uso del equipo pulverizador o los accesorios, tal como sobre presurización, modificación de piezas, uso de materiales y productos químicos incompatibles, o utilización de piezas dañadas o desgastadas, puede hacer que se rompan y causen la inyección de fluido u otras lesiones corporales graves, incendio, explosión o daños a la propiedad.

Siempre usar gafas, guantes, vestimentas protectoras y un respiradero, tal como recomiendan los fabricantes del fluido y del solvente.

SEGURIDAD EN EL USO DE LAS MANGUERAS

El fluido que escapa a alta presión por las mangueras puede ser muy peligroso. Si en la manguera se desarrolla un escape, una rotura o rajadura debido a cualquier tipo de desgaste, daño o maltrato, el chorro a alta presión emitido por allí puede causar una lesión por inyección u otras lesiones corporales graves o daños a la propiedad.

¡TODAS LAS MANGUERAS PARA FLUIDOS TIENEN QUE TENER GUARDAS DE RESORTE EN AMBOS EXTREMOS! Estas protegen las mangueras contra dobleces o retorceduras en los acoplamientos o cerca de ellos, los que podrían traducirse en roturas de la manguera.

Antes de usarlas, APRETAR bien firmes todas las conexiones. El fluido a alta presión puede desalojar un acoplamiento suelto o dejar que por él escape un chorro a alta presión.

NUNCA usar una manguera que está dañada. Siempre revisarla en busca de cortaduras, escapes, abrasión, cubierta abultada, o acoplamientos sueltos o dañados. Si llegara a encontrarse cualquiera de estas condiciones, reemplazar de inmediato la manguera. NO intentar reacoplar una manguera de alta presión o enmendarla con cinta adhesiva u otro material similar. Una manguera que ha sido remendada no aguantará el fluido al alta presión.

PELIGRO DE INCENDIO O EXPLOSION

El flujo a alta velocidad del fluido al pasar por la bomba y manguera crea electricidad estática. Si todas las partes del equipo pulverizador no tienen buena tierra, pueden ocurrir chispas, convirtiéndolo al sistema en algo peligroso. También, pueden producirse chispas al enchufar o desenchufar el cordón eléctrico o al usar un motor de gasolina. Estas chispas pueden inflamar los vapores de los solventes y el chorro de fluido pulverizado, partículas de polvo y otras sustancias inflamables, sea al aire libre o bajo techo, lo que podría causar una explosión o incendio y graves lesiones corporales y daños a la propiedad. Enchufar siempre la pulverizadora a un tomacorriente que se encuentre a por lo menos 6 m (20 pies) de la máquina y del área que se va a rociar. No enchufar o desenchufar ningún cordón eléctrico en el lugar donde se está rociando cuando todavía exista la posibilidad de que queden vapores inflamables en el aire.

Si ocurre una chispa de electricidad estática o incluso un ligero choque eléctrico mientras se usa el equipo, DEJAR DE PULVERIZAR DE INMEDIATO. Revisar todo el sistema en busca de una tierra apropiada. No usar de nuevo el sistema hasta haber identificado y solucionado el problema.

Puesta a tierra

Para reducir el riesgo de chispas estáticas, conectar a tierra la pulverizadora y todo el otro equipo de pulverizar que se use o se encuentre en el lugar que se va a rociar. CONSULTAR el código eléctrico de la localidad para las instrucciones sobre las conexiones a tierra exigidas para la zona y tipo de equipo. ASEGURAR de conectar a tierra todo este equipo pulverizador:

1. *Pulverizadora*: enchufar el cordón eléctrico, o cable extensor, cada uno con un enchuf de tres patas en buen estado, a un tomacorriente con puesta a tierra apropiada. No usar un adaptador. Todos los cables extensores tienen que tener tres hilos y una capacidad de 15 amperios.

Presión del sistema

Esta pulverizadora puede desarrollar 172 barías (2500 psi) de **PRESION DE TRABAJO MAXIMA**. Asegurar que todo el equipo pulverizador y sus accesorios tienen la capacidad para aguantar la presión máxima de trabajo de ningún componente o accesorio de este sistema.

Compatibilidad de fluido

Siempre leer las instrucciones del fabricante del fluido y solvente antes de usarlos en esta pulverizadora dadas en la página 34.

MANEJAR Y PASAR CUIDADOSAMENTE LAS MANGUERAS. No tirar de las mangueras para mover el equipo. No usar fluidos o solventes que sean incompatibles con el tubo interno y la cubierta de la manguera. NO exponer las mangueras a temperaturas sobre 82° C (180°F) o bajo -40°C (-40° F).

Continuidad del circuito de puesta a tierra de la manguera

La continuidad del circuito de puesta a tierra apropiado es esencial para mantener conectado a tierra el sistema pulverizador. Es indispensable revisar la resistencia eléctrica máxima de las mangueras de aire y de fluido por lo menos una vez a la semana. Si la manguera no tiene una etiqueta en la cual se especifica la resistencia eléctrica máxima, ponerse en contacto con el proveedor o fabricante de la manguera para la información sobre los límites de resistencia. Usar un metro de resistencia en la gama apropiada para comprobar la resistencia; si excede los límites recomendados, reemplazarla de inmediato. Es muy arriesgado tener una manguera sin puesta a tierra o con la puesta a tierra en malas condiciones. Leer también la información sobre **RIESGO DE INCENDIO O EXPLOSION**, más abajo.

2. *Mangueras para fluidos*: usar solamente mangueras con puesta a tierra de una longitud combinada de 150 m (500 pies), para asegurar buena continuidad a tierra. Referirse también al párrafo sobre **continuidad a tierra de la manguera**.
3. *Pistola*: hacer la puesta a tierra conectándola a una manguera de fluido y pulverizadora bien conectadas a tierra.
4. *Suministrar un recipiente*: de acuerdo al código local. Usar solamente baldes de metal, que sean conductivos. No colocar el balde en una superficie no conductiva, como papel o cartón, que interrumpe la continuidad a tierra.
5. *Objeto que se está rociando*: de conformidad con el código local.
6. *Todos los baldes de solvente* usados durante el lavado, de conformidad con el código local.
7. *Para mantener la continuidad a tierra durante el lavado o descarga de presión*, siempre apoyar una parte metálica de la pistola bien firme contra el costado de *balde de metal*, después apretar el gatillo.

Seguridad durante el lavado

Para reducir el riesgo de que se inyecte o salpique fluido en la piel, o que ocurra una descarga de electricidad estática, siempre seguir las INSTRUCCIONES PARA EL LAVADO, dadas en la página 13. Seguir el **procedimiento de descarga de presión** en la página 6, y quitar la *boquilla de metal* y usar la presión más baja posible de fluido durante el lavado.

SETUP

WARNING

If you are supplying your own hoses and spray gun, be sure the hoses are electrically conductive, that the gun has a tip guard, and that each part is rated for at least *2500 psi (172 bar) Maximum Working Pressure*. This is to reduce the risk of serious bodily injury caused by static sparking, fluid injection or over-pressurization and rupture of the hose or gun.

CAUTION

To avoid damaging the pressure control, which may result in poor equipment performance and component damage, follow these precautions.

1. Always use nylon spray hose at least 50 ft. (15.2 m) long.
2. Never use a wire braid hose; it is too rigid to act as a pulsation dampener.
3. Never install any shutoff device between the filter and the main hose. See Fig 9-1.
4. Never plug the filter outlet.

3. Check the electrical service.

- a. Be sure the electrical service is 120 V, 60 HzAC, 15 Amp (minimum), and that the outlet you use is properly grounded.
- b. DO NOT remove the grounding prong of the plug, and do not use an adapter.
- c. Use a grounded extension cord which has 3 wires having a minimum 12 gauge size, and a maximum length of 200 ft. (61 m). Longer lengths or smaller gauges will affect sprayer performance.

WARNING

Proper grounding is essential to reduce the risk of static sparking which can cause a fire or explosion and result in serious bodily injury and property damage.

Read the warning section FIRE OR EXPLOSION HAZARD on page 3 of this manual and ground the spray system as explained there.

4. Plug in the sprayer.

- a. Be sure the ON/OFF switch is OFF. See Fig 9-1.
- b. Plug the power supply cord into a grounded electrical outlet that is at least 20 ft. (6 m) away from the spray area to reduce the chance of a spark igniting the spray vapors.
- c. Do not remove the third prong of the power supply cord plug, which is the grounding prong, and do not use an adapter.

5. Flush the pump to remove the lightweight oil which was left in the pump to protect it from rust. Refer to the flushing guidelines on pages 13 and 14.

6. Prepare the paint according to the manufacturer's recommendations.

- a. Remove any skin that may have formed.
- b. Stir the paint to mix pigments.
- c. Strain the paint through a fine nylon mesh bag (available at most paint dealers) to remove particles that could clog the filter or spray tip. This is probably the most important step toward trouble-free spraying.

1. Connect the hose and gun. See Fig 9-1.

- a. Remove the plastic cap plug from the filter outlet nipple and screw a minimum 50 ft. (15.2 m) fluid hose onto the nipple.
- b. Connect the 3 ft. (0.9 m) whip hose between the fluid hose and the gun inlet connection, for more flexible gun movement. If you have a Flex gun, route the hose through the hose guard before connecting it to the gun.
- c. DO NOT use thread sealant, and DO NOT install the spray tip yet!

2. Fill the packing nut/wetcup 1/3 full with Graco Throat Seal Liquid (TSL), supplied. Remove the plastic plug from the top of the pump first. See Fig 9-1.

SETUP

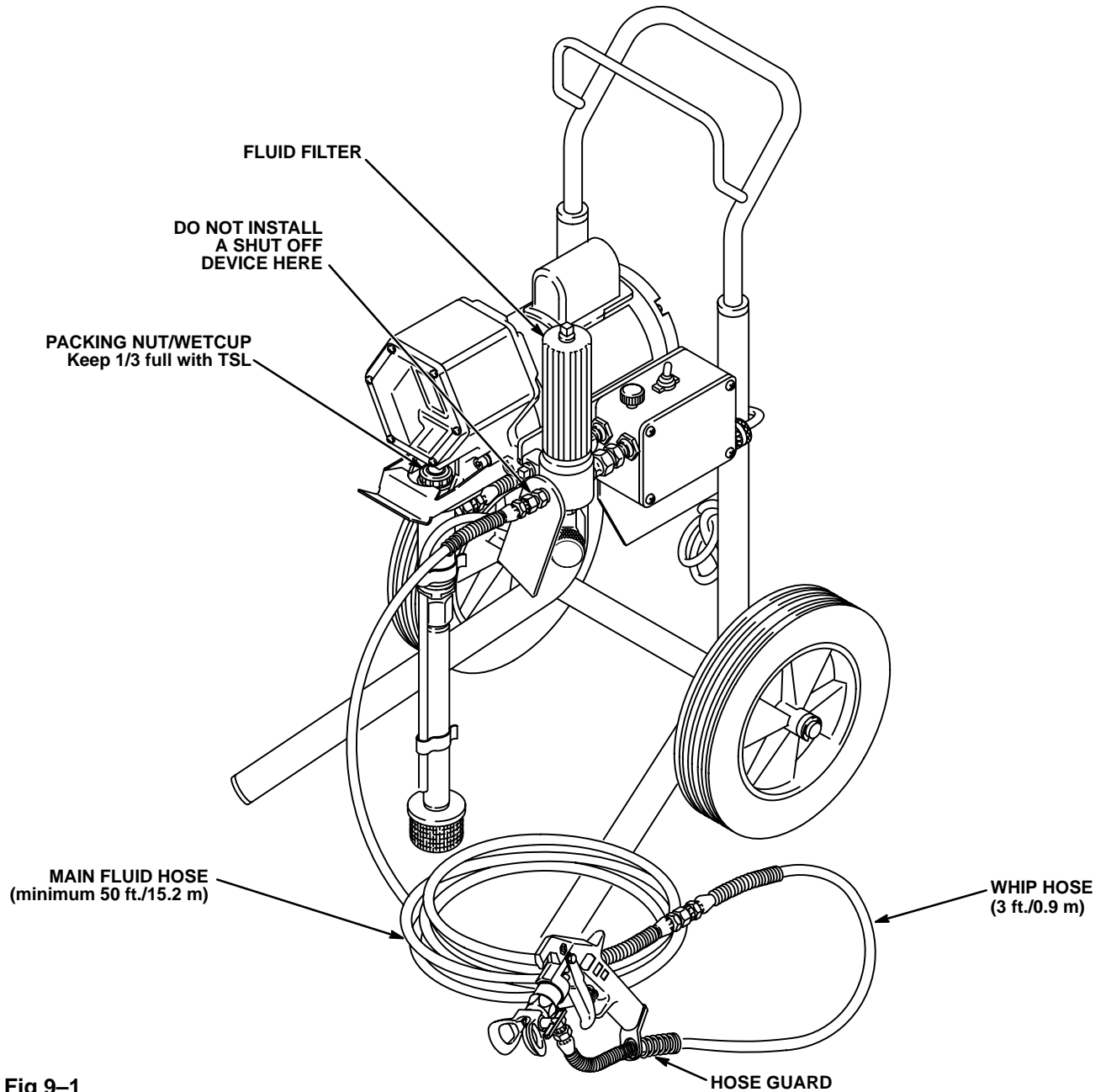

Fig 9-1

0663

OPERATION

WARNING

Pressure Relief Procedure

To reduce the risk of serious bodily injury, including injection; splashing in the eyes or on the skin; injury from moving parts or electric shock, always follow this procedure whenever you shut off the sprayer, when checking or servicing any part of the spray system, when installing, cleaning or changing spray tips, and whenever you stop spraying.

1. Engage the trigger safety latch.
2. Turn the ON/OFF switch to OFF.
3. Unplug the power supply cord.
4. Disengage the trigger safety latch. Hold a metal part of the gun firmly to the side of a grounded metal pail, and trigger the gun to relieve pressure.

5. Engage the trigger safety latch.
6. Open the pressure drain valve, having a container ready to catch the drainage. Leave the pressure drain valve open until you are ready to operate the sprayer again.

*If you suspect that the spray tip or hose is completely clogged, or that pressure has not been fully relieved after following the steps above, **VERY SLOWLY** loosen the tip guard retaining nut or hose end coupling and relieve pressure gradually. Then loosen the part completely. Clear the tip or hose obstruction.*

OPERATION

1. Prime the sprayer with paint.

- Close the pressure drain valve. See Fig 10-2.
- Don't install the spray tip yet!
- Put the suction tube into the paint container. You can hang the pail on the pail hanger. See Fig 10-2.
- Turn the pressure adjusting knob all the way counterclockwise to lower the pressure.
- Disengage the trigger safety latch. See the detail in Fig 10-2.
- Hold a metal part of the gun firmly against a grounded metal waste container. See Fig 10-1. Hold the trigger open, turn the sprayer ON, and slowly increase the pressure until the sprayer starts. Keep the gun triggered until all air is forced out of the system and the paint flows freely from the gun. Release the trigger and engage the trigger safety latch.

NOTE: If the pump is hard to prime, open the pressure drain valve. When fluid comes through the drain tube, close the drain valve. Disengage the trigger safety latch and repeat Step 1.f.

- Check all fluid connections for leaks; relieve pressure before tightening connections.

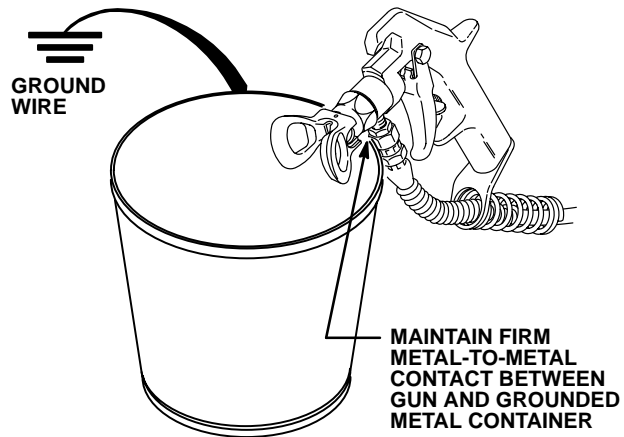

Fig 10-1

0664

2. Install the spray tip and tip guard.

- Be sure the trigger safety latch is engaged.
- Install the spray tip. If using the RAC IV, refer to manual 307-848, supplied with the gun, for installation instructions.

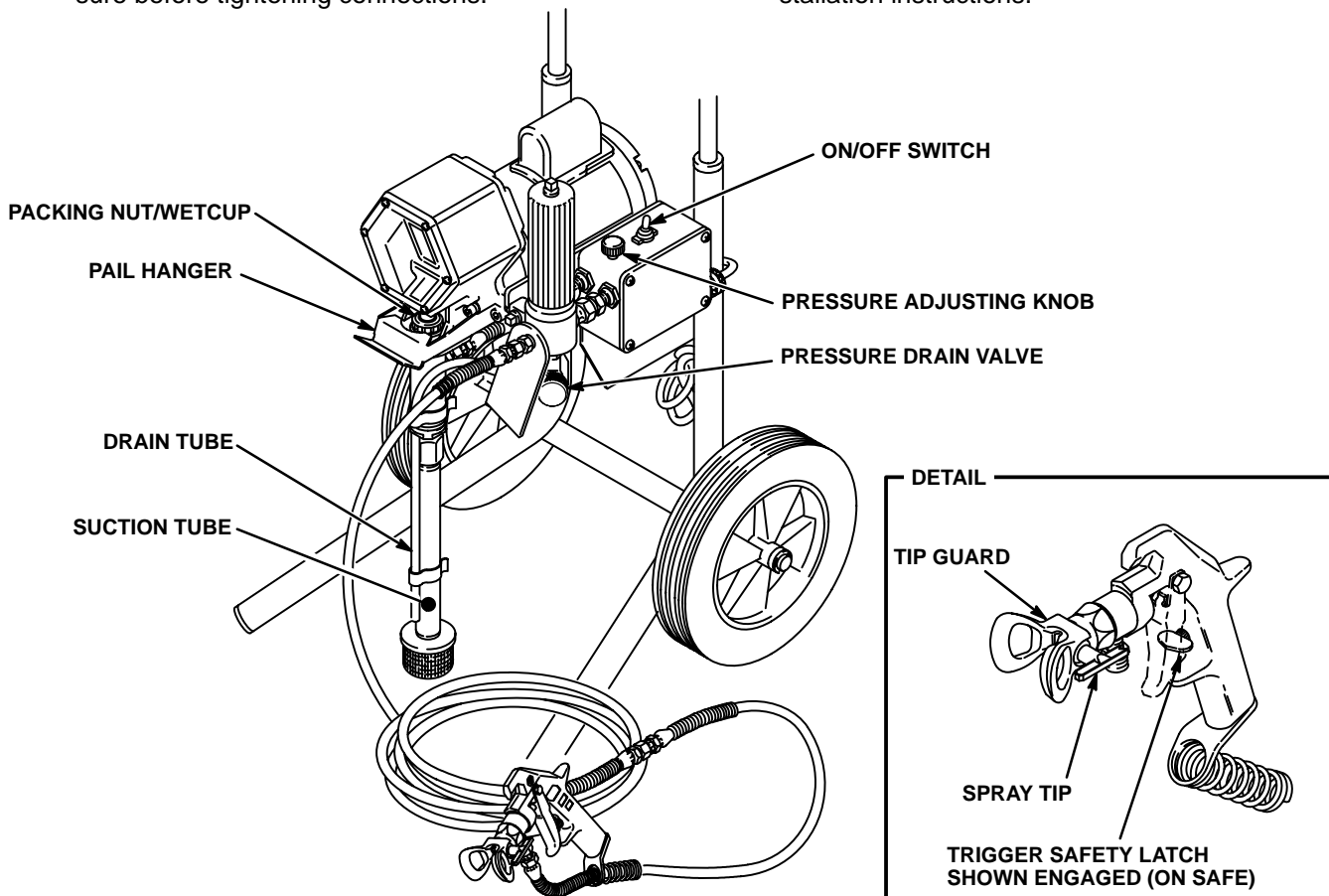



Fig 11-1

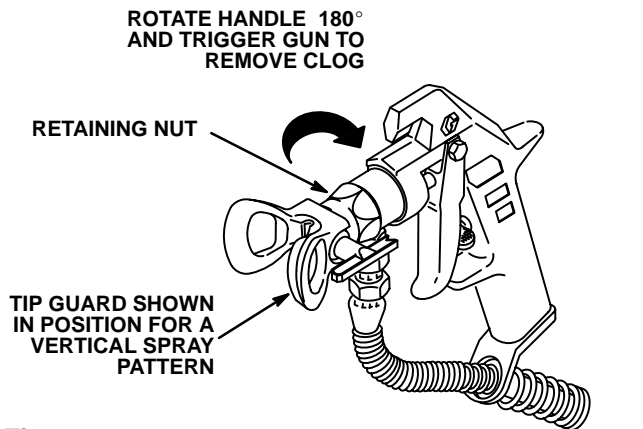

Fig 11-2

3. Adjust the spray pattern.

- Increase the pressure setting just until spray from the gun is completely atomized. See Fig 11-1. To avoid excessive overspray and fogging, and to decrease tip wear and extend the life of the sprayer, always use the lowest possible pressure needed to get the desired results.
- If more coverage is needed, use a larger tip rather than increasing the pressure.
- Test the spray pattern. To adjust the direction of the spray pattern, engage the trigger safety latch and loosen the retaining nut. Position the tip guard horizontally for a horizontal pattern or vertically for a vertical pattern. Then tighten the retaining nut. See Fig 11-2.

4. Cleaning a Clogged Tip

WARNING

To reduce the risk of serious bodily injury from injection, use extreme caution when cleaning or changing spray tips. If the spray tip clogs while spraying, engage the trigger safety latch immediately, then follow the procedure in Steps 4a to 4e, below.

NEVER wipe off buildup around the spray tip until pressure is fully relieved and the trigger safety latch is engaged.

- Clean the front of the tip frequently during operation. First the relieve pressure; see page 9. Then use a solvent-soaked brush to clean the tip and to reduce fluid build up and tip clogging.
- If the spray tip does clog, release the gun trigger, and engage the trigger safety latch.
- If using the RAC IV Spray Tip Kit, rotate the RAC IV handle 180°. See Fig 11-2. Disengage the trigger safety latch. Trigger the gun into a grounded waste container. Engage the trigger safety latch again. Return the handle to the original position.

If using a spray tip which is not self-cleaning, VERY SLOWLY loosen the tip guard retaining nut or hose coupling to relieve pressure gradually, then loosen the part completely. Clear the tip or hose obstruction, and reassemble it.

- Disengage the trigger safety latch, and resume spraying.
- If the tip is still clogged, engage the trigger safety latch, shutoff and unplug the sprayer, and open the pressure drain valve to relieve pressure. Remove the spray tip and clean it.
- Instructions for cleaning the RAC IV are given in manual 307-848.

SHUTDOWN AND CARE

1. **Check the packing nut/wetcup daily.** First relieve the pressure; see page 9. Be sure the wetcup is 1/3 full of TSL at all times to help prevent fluid buildup on the piston rod and premature wear of packings. The packing nut should be tight enough to stop leakage, but no tighter. Overtightening may cause binding and excessive packing wear. See Fig 12-1.
2. **Clean the fluid filter often** and before storing the sprayer. First relieve pressure; see page 9. See manual 307-273, supplied, for the filter cleaning procedure.
3. **Flush the sprayer at the end of each work day** and fill it with mineral spirits to help prevent pump corrosion and freezing. Refer to the flushing guidelines on pages 13 and 14.

CAUTION

Never leave water or any paint in the sprayer overnight to: (1) prevent pump corrosion; (2) prevent the fluid from freezing in the pump and pressure control which can cause loss of pressure, stalling or serious sprayer damage.

Always use mineral spirits for the final flush, relieve pressure and leave the mineral spirits in the sprayer.

4. **For very short shutoff periods,** leave the suction tube in the paint, relieve the pressure, and clean the spray tip.
5. **Coil the hose** and hang it on the cart's hose rack when storing it, even for overnight, to help protect the hose from kinking, abrasion, coupling damage, etc. See Fig 12-2.
6. **For the Lo-Boy cart,** use the brackets on the side of the cart to hold the suction assembly. See the Parts Drawing on page 31.
7. **Lubricate the bearing housing** after every 100 hours of operation. Remove the drive housing cover. Fill the bearing housing with SAE non-detergent oil. See Fig 12-3.

WARNING

Refer to the warning section HOSE SAFETY on page 3 for information on the hazard of using damaged hoses.

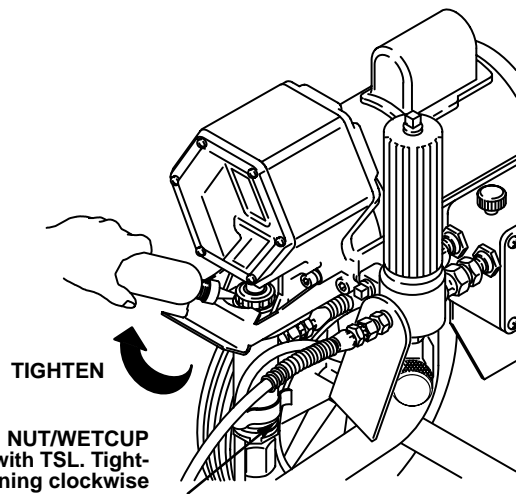

Fig 12-1

0665

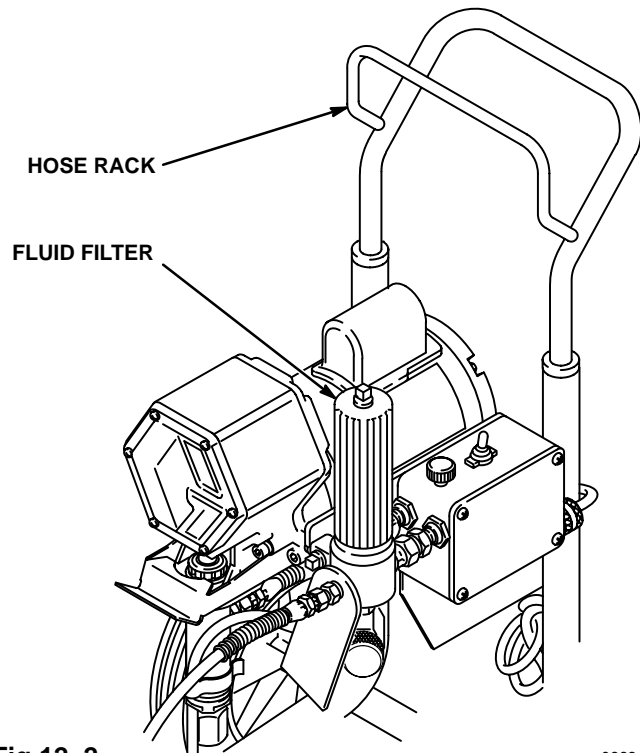

Fig 12-2

0663

EVERY 100 HOURS OF OPERATION FILL BEARING HOUSING CAVITY WITH SAE NON-DETERGENT OIL

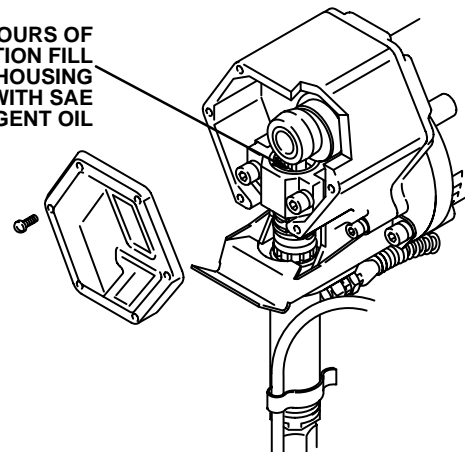

Fig 12-3

0670

WHEN TO FLUSH

NOTE: The **Pressure Relief Procedure Warning** is on page 16.

CAUTION

NEVER leave water or water-base paint in the sprayer if there is the slightest chance it could freeze. Flush out the water or water-base paint with mineral spirits. If water freezes in the pressure control tube, it prevents the sprayer from being started, and causes serious damage to the pressure control.

1. **New Sprayer.** The sprayer was factory tested in lightweight oil, which was left in to protect the pump parts.

Before using water-base paint, flush with mineral spirits, followed by a soapy water flush, and then a clean water flush.

Before using oil-base paint, flush with mineral spirits, only.

2. **Changing Colors.** Flush with a compatible solvent such as mineral spirits or water.

3. **Changing from water-base to oil-base paint.**
Flush with warm, soapy water, then mineral spirits.
4. **Changing from oil-base to water-base paint.**
Flush with mineral spirits, followed by warm, soapy water, and then a clean water flush.
5. **Storage.**

Water-base paint: Flush with water, and then mineral spirits. Leave the pump, hose and gun filled with mineral spirits. Shut off the sprayer and open the pressure drain valve to relieve pressure.

Oil-base paint: Flush with mineral spirits. Shut off and unplug the sprayer, open the pressure drain valve to relieve pressure.

6. **Startup after storage.**

Before using water-base paint, flush out the mineral spirits with soapy water, and then with clean water.

When using oil-based paint, flush out the mineral spirits with the paint to be sprayed.

NOTE: HOW TO FLUSH is on page 14.

HOW TO FLUSH

1. Relieve pressure. See page 16.
2. Remove the filter bowl and screen; see instruction manual 307–273, supplied. Clean the screen separately and install the bowl (only) to flush it. See Fig 14–1.
3. Close the pressure drain valve.
4. Pour one-half gallon (2 liters) of compatible solvent into a grounded metal pail. Put the suction tube in the pail.
5. Remove the spray tip from the gun.

WARNING

To reduce the risk of static sparking and splashing when flushing, always remove the spray tip from the gun, and hold a metal part of the gun firmly to the side of, and aimed into, a grounded metal pail

6. Disengage the trigger safety latch. Point the gun into a grounded metal waste container. With metal part of the gun firmly touching the metal container, squeeze the gun trigger. See Fig 14–2. This procedure reduces the risk of static sparking and splashing. Start the sprayer, trigger the gun, and slowly turn the pressure adjusting knob clockwise just until the pump starts. Keep the gun triggered until clean solvent comes from the nozzle. Release the trigger and engage the trigger safety latch.
7. Check all fluid connections for leaks. If any connections leak, first relieve the pressure. Tighten the connections. Start the sprayer. Recheck the connections for leaks.
8. Remove the suction tube from the pail. Disengage the trigger safety latch. Trigger the gun to force solvent from the hose. **Do not run the pump dry for more than 30 seconds to avoid damaging the pump packings!** Relieve the pressure.
9. Unscrew the filter bowl and reinstall the clean screen. Reinstall the bowl, hand tight only.

10. Remove the suction tube assembly and clean it separately. Flushing alone may not thoroughly clean these parts.
11. If you flushed with mineral spirits and are going to immediately use a water-base paint, flush with soapy water followed by a clean water flush. If you are storing the sprayer, leave the mineral spirits in it. Relieve pressure.
12. Leave the pressure drain valve open until you are ready to use the sprayer again.

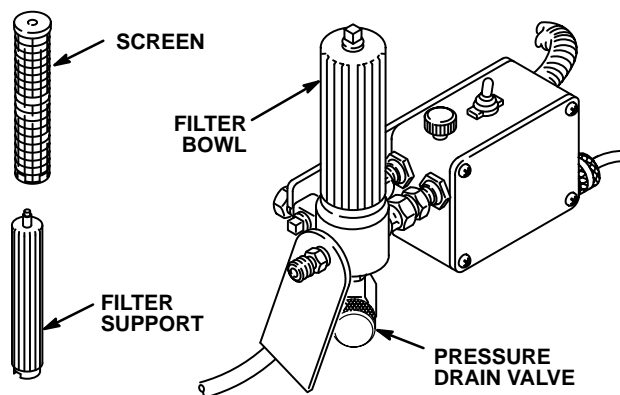

Fig 14–1

0671

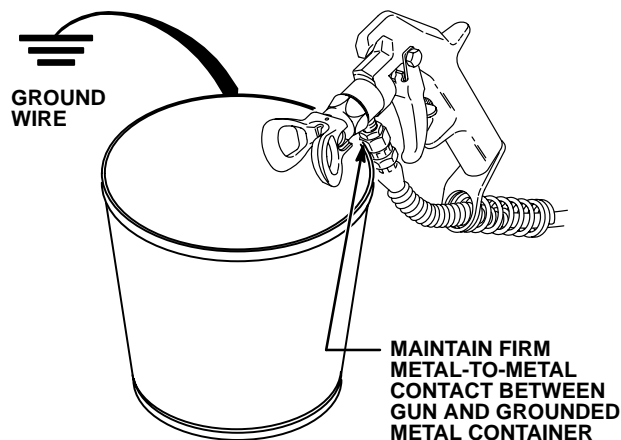

Fig 14–2

0664

APPLICATION METHODS

Always hold the gun perpendicular to the work surface and at an even 12 to 14 in. (300 to 356 mm) from the surface you are spraying. See Fig 15-1.

Begin moving the gun in a horizontal direction at a steady rate. Start the spray stroke off the target surface and pull the trigger as the gun is moving. Then, while the gun is still moving, and as you approach the other edge of the work surface, release the trigger. This method avoids excess paint buildup at the end of each stroke.

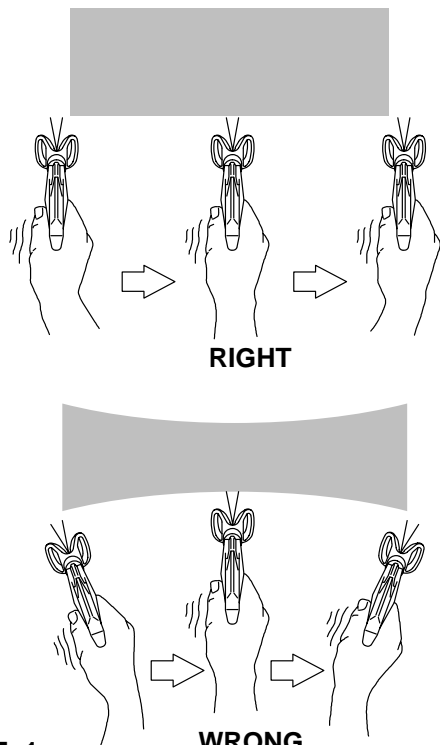

Fig 15-1

0072

Move the gun at a speed that provides a full, wet coating to be applied without runs or sags. Lap each stroke 50% over the previous stroke to produce a uniform paint thickness. Spray in a uniform pattern alternately from right to left and then left to right to get a professional finish. See Fig 15-2.

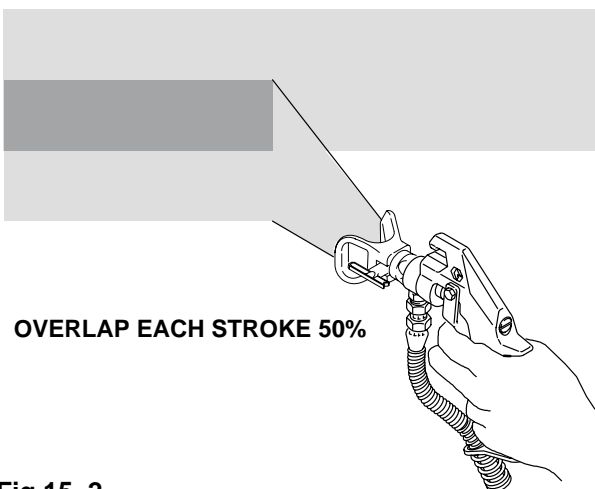

Fig 15-2

0672

The best way to control the rate of coverage is with the gun tip size. A small tip orifice applies less paint. A larger tip orifice applies more paint. The width of the pattern depends on the fan pattern of the tip you choose.

Do not try to increase coverage by increasing the fluid pressure! Using the lowest pressure necessary to get the desired paint atomization will help prolong the life of your sprayer and minimize paint lost by overspray.

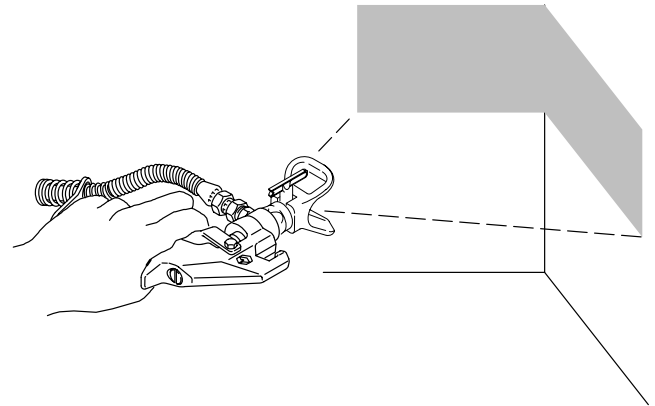

Fig 15-3

0673

For interior corners, aim the gun toward the center of the corner to be sprayed. By dividing the spray pattern this way, the edges on both sides are sprayed evenly. See Fig 15-3.

If there is a wind, angle the spray pattern into the wind to minimize drifting. Paint from the ground to the roof.

Shrubs. Tie back shrubs with rope and stakes. Cover them with a canvas dropcloth as the painter approaches the area. Remove the dropcloth as soon as the area is painted to prevent damage to the shrubs.

Concrete walks. If the walkways will be walked on, cover them with a canvas dropcloth to avoid slipping. Otherwise a plastic dropcloth can be used.

Electrical outlets and lamps. Protect electrical outlets with masking tape. Cover lamps with plastic bags secured with masking tape.

Nearby objects. Move portable upwind of the surface to be sprayed. If there is a nearby home, make a protective barrier by hanging plastic between two long poles.

TROUBLESHOOTING GUIDE

WARNING

Pressure Relief Procedure

To reduce the risk of serious bodily injury, including fluid injection, splashing in the eyes or on the skin, or injury from moving parts, always follow this procedure when you shut off the sprayer, when checking, adjusting or cleaning the system, and when changing spray tips.

1. Engage the gun safety latch.
2. Turn the ON/OFF switch to OFF.
3. Unplug the power supply cord.

4. Disengage the gun safety latch. Hold a metal part of the gun firmly to the side of a grounded metal pail, and trigger the gun.
5. Engage the gun safety latch.
6. Open the fluid pressure drain valve and leave it open until you start the sprayer again.

If you suspect the hose or spray tip is completely clogged or that pressure is not fully relieved after following the steps above, VERY SLOWLY loosen the tip guard retaining nut or hose end coupling and relieve pressure gradually. Now loosen the part completely. Clear the tip or hose obstruction.

Check everything in the chart before disassembling the sprayer.

PROBLEM	CAUSE	SOLUTION
Electric motor won't run	Power cord or extension cord unplugged, or damaged, or building circuit breaker or fuse has tripped	Check, reset or replace.
	Motor overload switch ¹ has opened	Unplug power supply cord, relieve pressure, allow motor to cool, clear motor air passages of dirt and overspray, decrease pressure.
	Pressure setting too low	Increase pressure.
	Pressure control frozen ² or damaged by over-pressurization ³	Try to thaw, or replace pressure control.
Electric motor stops while spraying	Power cord or extension cord unplugged, or damaged, or building circuit or fuse is blown	Check, reset or replace.
	Motor overload switch ¹ has opened	Unplug power supply cord, relieve pressure, allow motor to cool, clear motor air passages of dirt and overspray, decrease pressure.
	Pressure setting too low	Increase pressure.
	Spray tip or filter plugged	Remove and clean.
	Wrong type extension cord	Use maximum 200 ft. (61 m), 3 wires, 12 gauge, grounded extension cord.
Electric motor runs, but low paint output or no paint output; or pump is not stroking See the PROBLEM , "Not enough paint pressure", on page 17, also	Piston ball check not seating	Service the pump. See page 18.
	Piston packings worn or damaged	Replace the piston. See page 18.
	Intake valve ball check not seating	Service the pump. See page 18.
	Pump is frozen	Thaw ²
	Filter element installed upside down	Install element correctly. See page 14 or manual 307-273.
	Pressure control frozen ² or damaged by over-pressurization ³	Try to thaw, or replace pressure control.
	Drive assembly damaged	Replace drive housing. See page 21.
	Displacement pump worn or damaged	Replace displacement pump. See page 18.
	Sprayer is not primed.	Prime sprayer. See page 10.

PROBLEM	CAUSE	SOLUTION
Electric motor labors when starting, and trips building circuit breaker or fuse	Motor capacitor has failed	Replace the capacitor. See page 22.
	Circuit board has failed	Replace the circuit board. See page 23.
Paint leaks into wet-cup	Throat packings are worn or damaged	Replace the packings. See page 18.
Excessive surging from spray gun	Spray tip or fluid filter is plugged	Disassemble and clean.
	Spray tip too big or worn	Change the spray tip.
	Paint too viscous	Thin the paint.
	Wrong type hose	Use minimum 50 ft. (15.2 m), static-free nylon hose (wire braid hose is unacceptable).
Not enough paint pressure	Pressure setting too low	Increase pressure.
	Spray tip too big or worn	Change the spray tip.
	Pressure control frozen ² or damaged by over-pressurization ³	Try to thaw, or replace pressure control.
	Displacement pump worn or damaged	Replace the displacement pump. See page 18.
Tails or fingers in spray pattern	Pressure setting too low	Increase pressure.
	Fluid outlet filter is dirty or clogged	Clean the filter. See page 14 or manual 307-273.
	Spray tip too big or worn	Change the spray tip.
	Fluid supply is low or empty	Refill and prime the pump. See page 10. Check fluid supply often to prevent running the pump dry.
	Paint too viscous	Thin the paint.
	Wrong type hose	Use minimum 50 ft. (15.2 m), static-free nylon hose (wire braid hose is unacceptable).
Paint runs or sags	Spray tip too big or worn	Change the spray tip.
Spitting from gun	Air in fluid pump or hose	Check for loose connections at pump intake and tighten. Then prime the pump. See page 10.
	Tip partially clogged	Clear the tip. See page 11.
	Fluid supply is low or empty	Refill and prime the pump. See page 10. Check fluid supply often to prevent running the pump dry.
Static sparking from the gun	Spray or work being sprayed is not properly grounded	Correct problem before continuing. Follow the warning section, FIRE OR EXPLOSION HAZARD on page 3.

¹ The electric motor has an over-temperature switch which automatically resets upon cooling. If it opens and the electric motor shuts itself off, unplug the power supply cord and let the sprayer cool for 30 to 60 minutes. Always use the lowest pressure setting needed when spraying. Prevent overspray from restricting the motor air passages; check and clean often.

² Freezing results from failure to replace the water-base paint or flushing water with mineral spirits, and usually causes permanent damage to the pressure control.

³ Over-pressurization results from (1) using less than 50 ft. (15.2 m) of nylon spray hose, (2) from using a wire braid spray hose, (3) from adding a shutoff device between the pump outlet and the spray gun, (4) from attaching a spray hose to the pressure drain valve, or (5) from using a clogged or incorrectly assembled filter.

DISPLACEMENT PUMP

WARNING

To reduce the risk of serious bodily injury, follow the **Pressure Relief Procedure Warning** on page 16 before checking or repairing any part of the spray system. *Unplug the sprayer!*

Removing the Pump. See Fig 18-1.

1. Flush the sprayer. Relieve pressure.
2. For the upright sprayer, remove the clips (110,114) and drain tube (125) from the pump.
3. Hold the intake valve (222) steady with a wrench and unscrew the adapter (38).
4. Unscrew the hose (52).
5. Use a screwdriver to push the retaining spring (33) aside, and then push out the pin (34).
6. Loosen the locknut (112) and unscrew the pump (58).

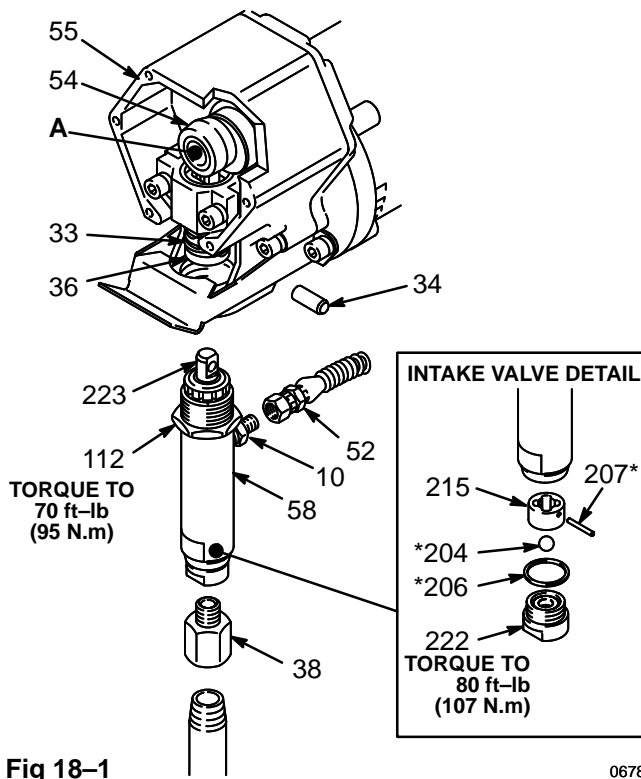

Reinstalling the Pump. See Fig 18-1.

1. Rotate the crankshaft (A) so the connecting rod (54) is in its lowest position. The pump piston rod (223) should protrude about 1 in. (25 mm) above the pump cylinder.
2. Screw the pump into the drive housing (55) until the pin holes are aligned with the pump coupling (36). Insert the pin (34). Position the spring (33) so it covers the ends of the pin.

WARNING

Be sure the retaining spring (33) is firmly and completely in the groove of the connecting rod to prevent the pin (34) from working loose due to vibration. See Fig 18-1.

If the pin works loose, it or other parts could break off due to the force of the pumping action. These parts could be projected through the air and result in serious bodily injury or property damage, including damage to the pump, connecting rod or bearing housing.

3. Screw the pump further into the drive housing (55) until it stops at the locknut (112). Unscrew the pump just until the nipple (10) faces straight back.
4. Torque the locknut (112) to 70 ft-lb (95 N.m).
5. Reassemble the remaining parts, in the reverse order of removal.

Disassembly. See Fig 19-1, except where noted.

1. Remove and disassemble the intake valve (222). If no further service is needed, reassemble the valve, using a new gasket (206*). Torque the intake valve to 80 ft-lb (107 N.m). See Fig 18-1.
2. Remove the packing nut (221) and plug (201).
3. Tap the piston rod (223) down with a plastic mallet. Pull the rod out the bottom of the cylinder (216).
4. Remove the packings and glands from the throat of the cylinder (216).
5. Clamp the flats of the piston rod (223) in a vise. Unscrew the retaining nut (214). Unscrew the piston valve (224) from the rod. Remove all parts from the piston.

Reassembly Notes

- A. Packing Repair Kit 222-587 is available. Parts included in the kit are marked with an asterisk (*) in the text and drawings.
- B. Clean all parts thoroughly. Check the outside of the piston rod (223) and the inside of the cylinder (216) for scoring or scratches, which prevent the packings from sealing properly. Replace all worn parts.
- C. Alternate polyethylene and leather packings as shown in Fig 19-1, starting with the polyethylene packings. Incorrect installation damages the packings and results in pump leakage. Notice that:
 - the lips of the throat v-packings face down;
 - the lips of the piston V-packings face up;
 - the lips of the U-cup seal (205) face down.
- D. Coat the piston rod and the inside of the cylinder with lightweight oil, and soak the packings in oil before reassembling.

DISPLACEMENT PUMP

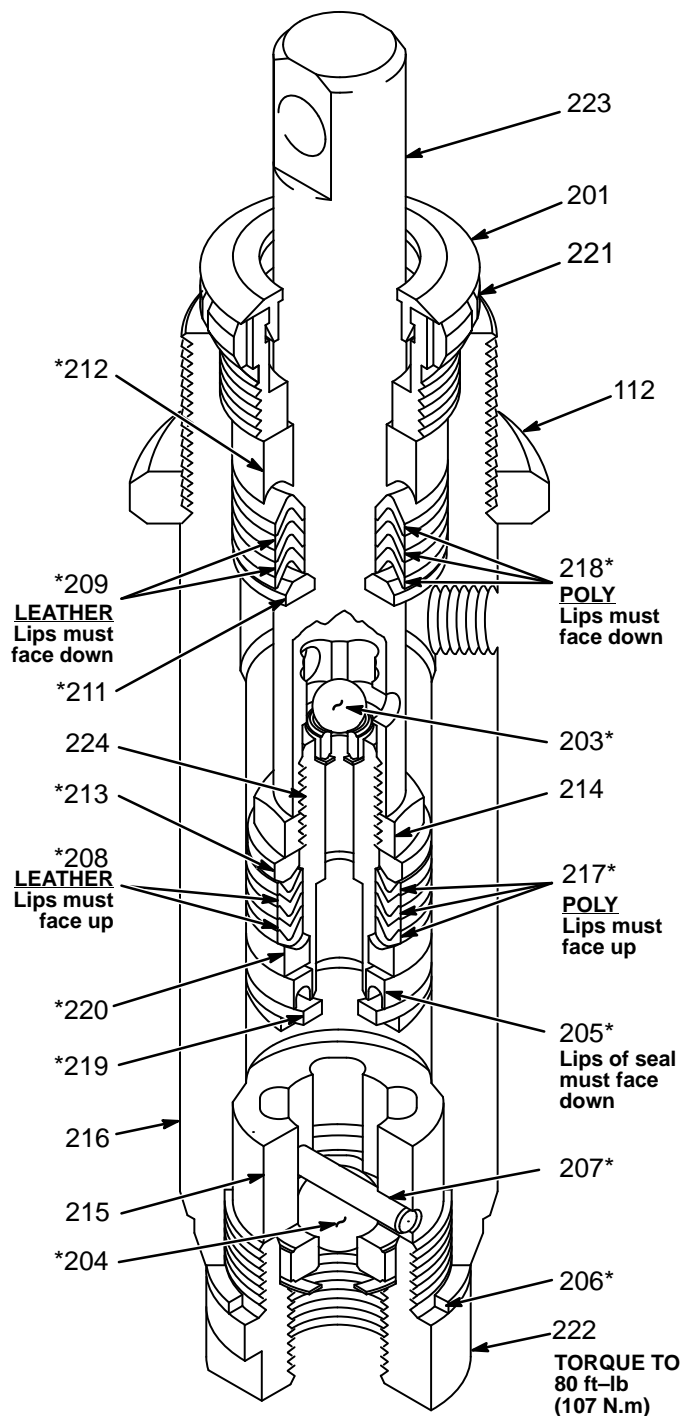

Fig 19-1

Reassembly Procedure

1. Stack these parts one at a time onto the piston valve (224): backup washer (219*), U-cup seal (205*) *lips down*, and female gland (220*), alternate the polyethylene and leather v-packings (217*, 208*) *lips up*, and then the male gland (213*). See Fig 19-1.

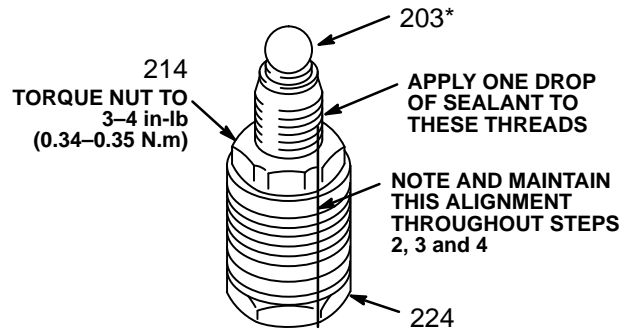

Fig 19-2

0082

2. Tighten the packing retaining nut (214) against the gland (213) and torque to 3-4 in-lb (0.34 - 0.35 N.m). See Fig 19-2.

NOTE: NOTE THE ALIGNMENT of the piston (224) to the nut (214). Maintain this alignment throughout Steps 2, 3 and 4.

3. Apply 1 drop only of sealant, supplied with the repair kit, to the piston valve threads. Place the small ball (203*) on the valve. See Fig 19-2. Hand tighten the valve into the rod (223) just until the nut contacts the rod. Place the flats of the displacement rod in a vise.

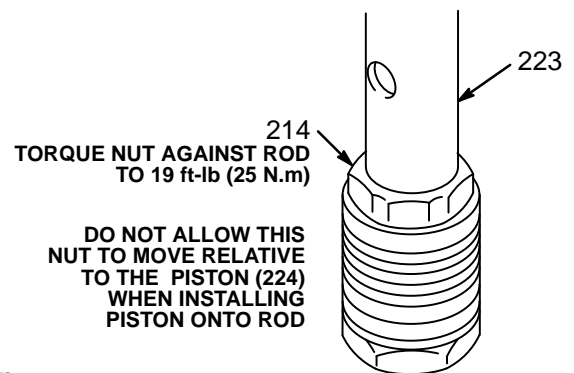

Fig 19-3

0083

4. Torque the nut (214) against the rod (223) to 19 ft-lb (25 N.m). Use two wrenches to maintain the alignment as mentioned in the **NOTE** above. See Fig 19-3.
5. Stack these parts one at a time into the top of the cylinder (216): male gland (211*), alternate the polyethylene and leather v-packings (218*, 209*) *lips down*, and then the female gland (212*). See Fig 19-1.
6. Loosely install the packing nut (221) and plug (201).
7. Insert the oiled piston rod (223) through the bottom of the cylinder.
8. Assemble the intake valve. Use a new gasket (206*). Screw the intake valve into the cylinder and tighten to 80 ft-lb (107 N.m). See Fig 19-1.
9. Screw down the cylinder locknut (112) until it is finger tight at the bottom of the external cylinder threads. See Fig 19-1.
10. Install the displacement pump on the sprayer. See page 18.

REPLACING THE CONNECTING ROD and BEARING

WARNING

To reduce the risk of serious bodily injury, including fluid injection or splashing in the eyes or on the skin, or injury from moving parts, always follow the **Pressure Relief Procedure Warning** on page 16 before checking, adjusting, cleaning or shutting off the sprayer. *Unplug the power supply cord.*

NOTE: Refer to Fig 20–1 for this procedure unless otherwise instructed.

1. Remove the displacement pump. See page 18.
2. Remove the front cover (35).
3. Remove the bearing housing screws (20).
4. Slide the bearing and connecting rod assembly (A) off the crankshaft (B).
5. Use a screwdriver to push the retaining spring (33) up. Remove the pin (34) and the coupling (36).
6. Clean and inspect the bearing housing (53) and connecting rod (54), including the needle bearing (D). Replace both parts if either is worn or damaged.
7. Clean and inspect the crankshaft (B). Wipe the crankshaft clean with a rag (don't use solvent). If the crankshaft is badly worn, replace the drive assembly (55). See page 21.

CAUTION

To extend the service life of the connecting rod bearing, lubricate it properly. After every 100 hours of operation, or whenever servicing the pump (whichever comes first), fill the cavity (E) in the connecting rod (54) with SAE non-detergent motor oil.

8. Coat the surfaces of the new connecting rod and bearing (C) with SAE non-detergent motor oil. Liberally pack the needle bearing (D) with industrial-grade, heavy-duty, extreme-pressure, lithium-soap grease.

9. Assemble the connecting rod (54) and bearing (53). Assemble the coupling (36) to the connecting rod and install the pin (34). Push the spring (33) over both ends of the pin (34).
10. Align the connecting rod (54) with the crankshaft (B) and push the bearing housing (A) onto the drive housing (55). Assemble the remaining parts.

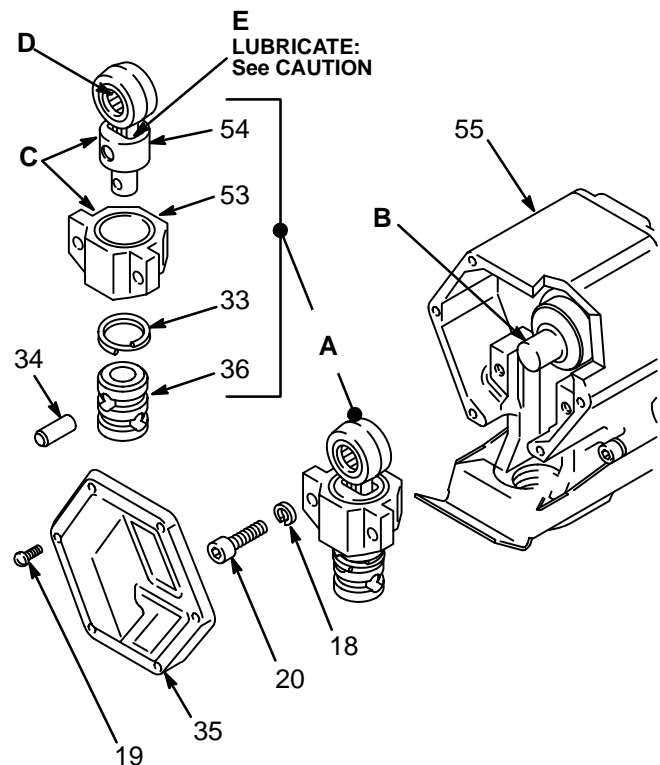

Fig 20–1

0075

REPLACING THE ELECTRIC MOTOR & CAPACITOR

WARNING

To reduce the risk of serious bodily injury, including fluid injection or splashing in the eyes or on the skin, or injury from moving parts, always follow the **Pressure Relief Procedure Warning** on page 16 before checking, adjusting, cleaning or shutting off the sprayer. *Unplug the power supply cord.*

1. Disconnect the hose at the displacement pump.
2. Remove the drive assembly. See page 21. The pump, connecting rod and bearing can stay assembled to the drive assembly.
3. Drive out the pin (27) and remove the gear (37). See Fig 22-2.
4. Remove the pressure control cover (41). Disconnect the motor leads as shown in Fig 22-1.
5. Unscrew the connector (13 and 303) nuts on both ends of the conduit (1). See Fig 22-1.
6. Remove the motor mounting screws (7). Lift the motor and carefully guide the wires through the pressure control connector (303). Remove the conduit (1) from wires. See Fig 22-2.

CAUTION

Pull the motor leads through the conduit one at a time to avoid loosening the terminals.

7. Loosen the locknut and unscrew the connector (13) from the motor. Do not twist the wires. See Fig 22-1.
8. Install the new motor in the reverse order of removal.

NOTE: Install the new circuit board (23f) which is included with a new motor. Do not reuse the old board. See page 26 for installation.

Capacitor

1. Remove the capacitor (23d) cover. See Fig 22-2. Remove the flag connectors from the old capacitor and connect them to the new capacitor. Replace the cover.

NOTE: The replacement capacitor includes a new resistor, installed.

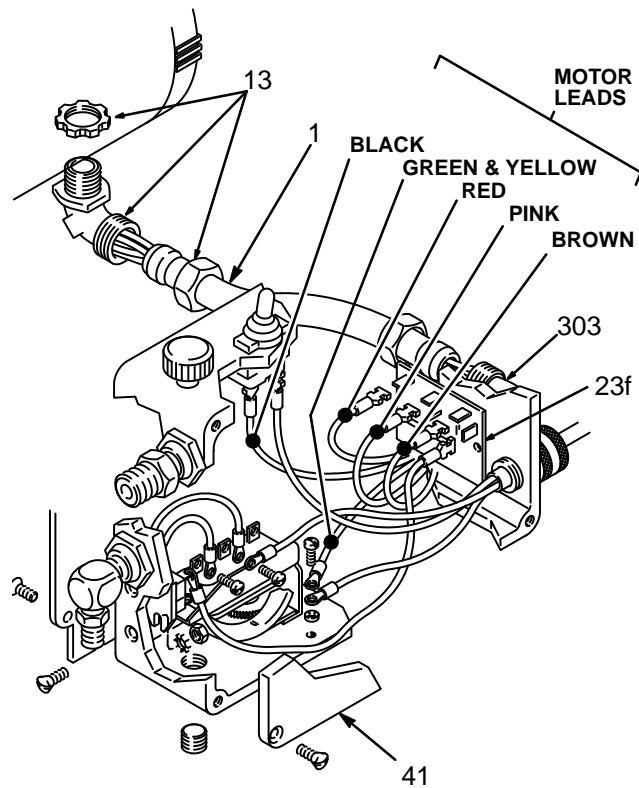

Fig 22-1

0749

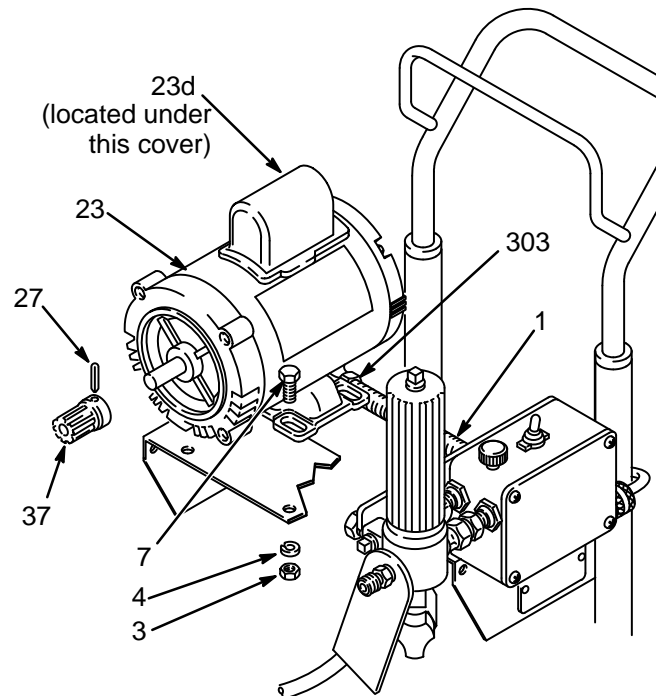

Fig 22-2

0675

REPLACING THE PRESSURE CONTROL & CIRCUIT BOARD

WARNING

To reduce the risk of serious bodily injury, including fluid injection or splashing in the eyes or on the skin, or injury from moving parts, always follow the **Pressure Relief Procedure Warning** on page 16 before checking, adjusting, cleaning or shutting off the sprayer. *Unplug the power supply cord.*

NOTE: A circuit board (23f) is not included with a new pressure control (50). However, it is included with a new motor and it can be ordered separately.

Be sure to order the correct circuit board. See the application information on page 26.

CAUTION

Do not allow the fittings (A) to move when removing the elbow (312) or nipple (313) from the pressure control, to avoid altering the factory setting of the pressure control or damaging the pressure control.

Circuit Board Removal

1. Remove the pressure control cover (41). Pull the circuit board (23f) out carefully, just enough to reach the wire terminals. Disconnect the leads. Remove the board. See Fig 23-1.

Pressure Control Removal

2. Disconnect the hose (52). See Fig 23-2.
3. Disconnect the remaining two motor leads (black and green/yellow). See Fig 23-1.
4. Remove the screws (7). See Fig 23-2.
5. Pull the pressure control (50) away from the conduit (1) and carefully guide the leads through the connector (303) one at a time. See Fig 23-1.
6. Remove the mounting bracket (40). Remove the fittings (302, 312, and 313). Remove the fluid filter (47). Install these parts on the new pressure control. See Fig 23-2.

Pressure Control Installation

7. Guide the motor leads into the new pressure control.
8. Position the circuit board in the pressure control so the wire connectors are at the top. Connect the leads to the board. Guide the leads into the pressure control, making sure they don't catch on anything. Slide the board into place.
9. Connect any other loose wires. See Fig 23-1.

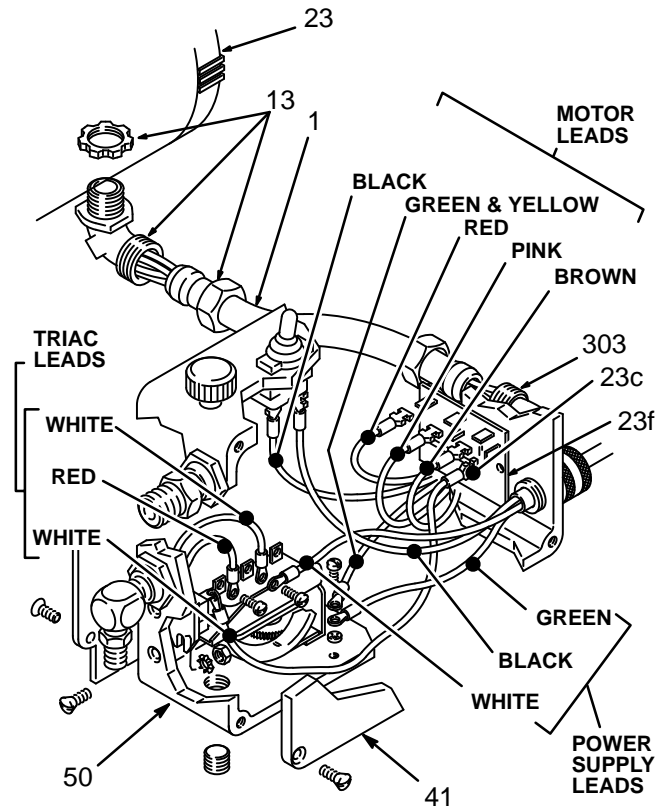

Fig 23-1

0749

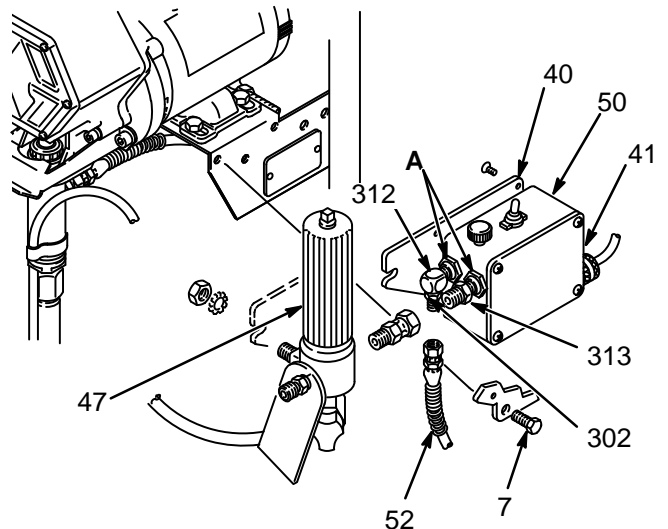

Fig 23-2

0677

10. Mount the pressure control on the cart.

11. **ADJUST THE PRESSURE CONTROL!** See page 24.

WARNING

Adjust the pressure control whenever a new or used pressure control or circuit board is installed, to reduce the risk of overpressurization which can result in component rupture, fire or explosion. Improper adjustment may also prevent the sprayer from obtaining the maximum working pressure, resulting in poor sprayer performance.

PRESSURE CONTROL ADJUSTMENT

WARNING

USE EXTREME CAUTION WHEN PERFORMING THIS ADJUSTMENT PROCEDURE to reduce the risk of a fluid injection injury or other serious bodily injury, which can result from component rupture, electric shock, fire, explosion or moving parts.

This procedure sets the sprayer to 2500 psi (172 bar) **MAXIMUM WORKING PRESSURE**.

Perform this procedure whenever the microswitch or pressure control assembly is reinstalled or replaced, to be sure the sprayer is properly calibrated.

Improper adjustment can cause the sprayer to over-pressurize and result in component rupture, fire or explosion. It may also prevent the sprayer from obtaining the maximum working pressure, resulting in poor sprayer performance.

NEVER attempt to increase the fluid outlet pressure by performing these adjustments in any other way. Normal operation of the sprayer at higher pressures could result in component rupture, fire or explosion. To perform this adjustment, however, the sprayer pressure must be *temporarily* increased above the normal working pressure.

Use a *new* 50 foot (15.2 m) spray hose, rated for at least 3000 psi (210 bar) **MAXIMUM WORKING PRESSURE**, when performing this procedure. A used, under-rated hose could develop a high pressure leak or rupture.

WARNING

Pressure Relief Procedure

To reduce the risk of serious bodily injury, including fluid injection, splashing in the eyes or on the skin, or injury from moving parts, always follow this procedure when you shut off the sprayer, when checking, adjusting or cleaning the system, and when changing spray tips.

1. Engage the gun safety latch.
2. Turn the ON/OFF switch to OFF.
3. Unplug the power supply cord.

4. Disengage the gun safety latch. Hold a metal part of the gun firmly to the side of a grounded metal pail, and trigger the gun.
5. Engage the gun safety latch.
6. Open the fluid pressure drain valve and leave it open until you start the sprayer again.

If you suspect the hose or spray tip is completely clogged or that pressure is not fully relieved after following the steps above, VERY SLOWLY loosen the tip guard retaining nut or hose end coupling and relieve pressure gradually. Now loosen the part completely. Clear the tip or hose obstruction.

Service Tools Needed:

- **NEW** 50 foot (15.2 m), 3000 psi (210 bar), flexible nylon, airless spray hose, Part No. 223-541
- 0-5000 psi (0-350 bar) fluid-filled pressure gauge, Part No. 102-814
- Needle valve, Part No. 102-715 or 103-067
- 3/8 in. socket wrench
- 5 gallon pail and water
- Mineral spirits

1. Follow the **Pressure Relief Procedure Warning**, above.
2. Connect the new 50 ft. (15.2 m) spray hose to the sprayer outlet. Install the needle valve on the other end of the hose. Install the fluid-filled pressure gauge in the top port of the fluid filter.
3. Remove the pressure control cover (41) and the plug (121) (*see the parts drawings*) from the bottom of the pressure control. In Step 6, you will insert the 3/8 in. socket wrench through the plug hole (C) to engage the pressure adjustment nut (B) which is located on the bottom of the pressure control knob shaft. See Fig 25-1.

PRESSURE CONTROL ADJUSTMENT

NOTE: See Fig 25–1 for the following procedure.

4. Open the needle valve slightly. Turn the pressure control knob (A) to the minimum setting.
5. Plug in the sprayer and turn the switch ON. Increase the pressure setting just enough to start the sprayer. Prime the hose, being sure to eliminate all air from the system.
6. Open the needle valve a little more—enough to allow the pump to run continuously—and turn the pressure control knob to maximum. Now, very slowly start to close the needle valve, but don't close it all the way. Observe the pressure at which the pump stalls, which should be approximately 2500 psi (172 bar).

NOTE: The slower the pressure is raised, the easier it is to note the exact stall pressure. Closing the needle valve quickly causes the pressure to rise too fast which gives a false reading.

If the pressure is lower than 2500 psi (172 bar):

Unplug the sprayer. Relieve pressure. Insert the wrench and untighten the pressure adjustment nut 1/8 turn or less, then repeat steps 5 and 6.

If the pressure is higher than 2500 psi (172 bar):

Unplug the sprayer. Relieve pressure. Insert the wrench and tighten the pressure adjustment nut 1/8 turn or less and repeat steps 5 and 6. Repeat this procedure until the proper stall pressure is obtained.

7. Now check to see at what pressure the sprayer starts to run again after it stalls. Plug in the sprayer, turn it on, close the needle valve, and set the pressure at maximum. Allow the sprayer to run until it stalls.

8. Open the needle valve very slowly while observing the pressure gauge. Check to see if the pressure drops to approximately 2100 psi (147 bar) before starting again.

If the pressure is not 2100 psi (147bar):

Shut off and unplug the sprayer, but do not relieve pressure. Turn the differential wheel (D) just one notch and repeat Steps 5 and 6. Check the pressure drop again, and repeat if necessary.

NOTE: If you adjust the differential wheel, recheck the stall pressure (steps 5 and 6) to be sure the stall pressure has not changed.

9. Follow the **Pressure Relief Procedure Warning** on page 24. Flush the water out with mineral spirits. Relieve pressure again. Install the plug (121) and the pressure control cover (41). Remove the test hose, needle valve and pressure gauge.

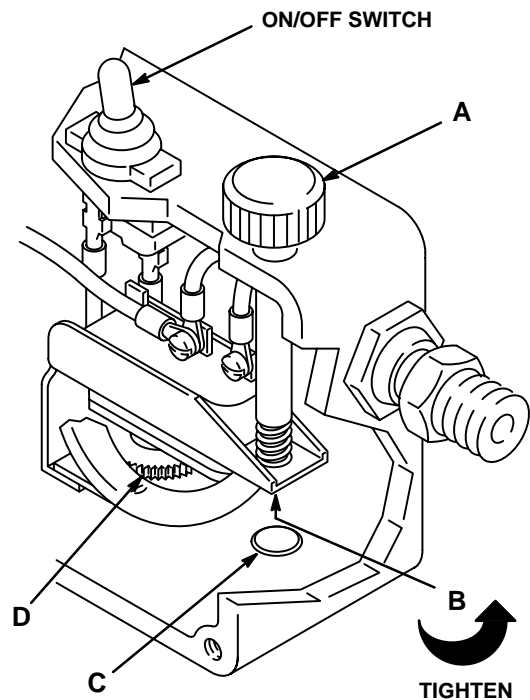

Fig 25–1

0750

PARTS DRAWING & LIST – PRESSURE CONTROL

Part No. 215-860

Ref No. 50

Pressure Control Assembly

Includes replaceable items 301 to 316, as listed below

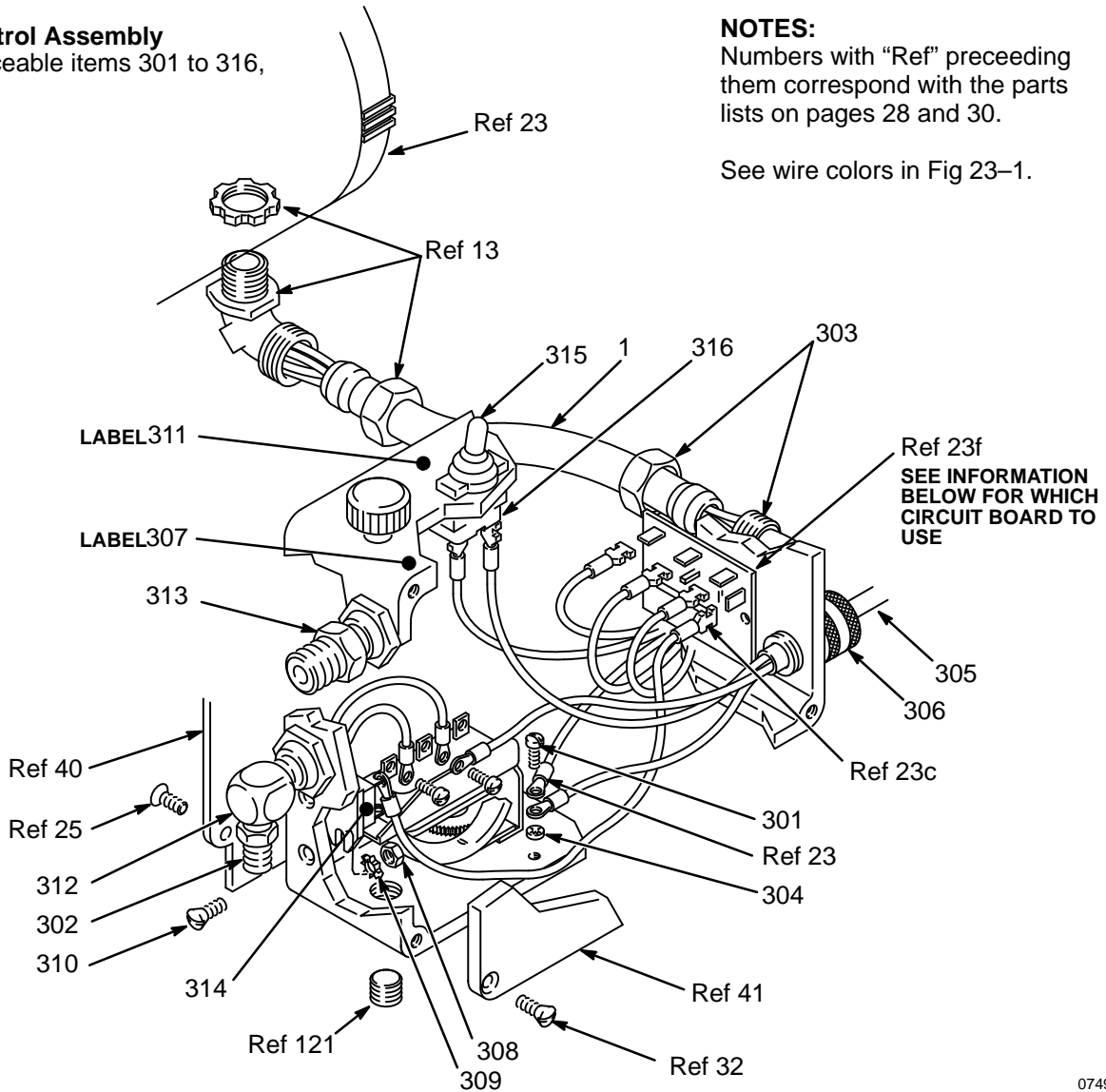

NOTES:
Numbers with "Ref" preceding them correspond with the parts lists on pages 28 and 30.

See wire colors in Fig 23-1.

0749

Ref No.	Part No.	Description	Qty
301	100-035	SCREW, mach, pan hd, 8-32 x 5/16"	1
302	162-453*	NIPPLE, 1/4 npsm x 1/4 npt	1
303	102-932	CONNECTOR, conduit, 90°	2
304	157-021	LOCKWASHER, int. shkprf, No. 8	1
305	217-492	CORD, power supply	1
306	108-295	RELIEF, strain	1
307	178-035‡	LABEL, caution	1
308	100-072	NUT, hex, mscr, 6-32	2
309	103-181	LOCKWASHER, No. 6	2
310	107-070	SCREW, mach, flat hd, 6-32 x 5/8"	2
311	178-797‡	LABEL, warning	1
312	100-840*	ELBOW, street, 1/4 npt(f x m)	1
313	157-350*	ADAPTER, 3/8 npt x 1/4 npt	1
314	218-916	TRIAC	1
315	105-659	BOOT, switch	1
316	105-679	TOGGLE, switch	1

‡Extra warning labels available at no cost.

* **NOTE:** A new pressure control (50) does not include items 302, 312, 313 or any items preceded by "Ref" in the above drawing.

CIRCUIT BOARD APPLICATIONS

Identify the correct circuit board for your sprayer by matching the information below. The circuit boards may be purchased separately, but all replacement motors for this sprayer include a new circuit board.

105-683 used in	Circuit Board P/N and style	223-597 used in
220-726, A & B 231-001, A	Sprayer, Series	220-726, C 231-001, B
218-949	Graco Motor P/N	224-727
Yes	External Motor Fan?	No
1112125400	Franklin Motor P/N	1101007414

DISPLACEMENT PUMP PARTS DRAWING & LIST

Model 218-215, Series C
Carbon Steel Displacement Pump
 Includes items 201 to 224

NOTE: See the repair instructions for important torque values and procedures

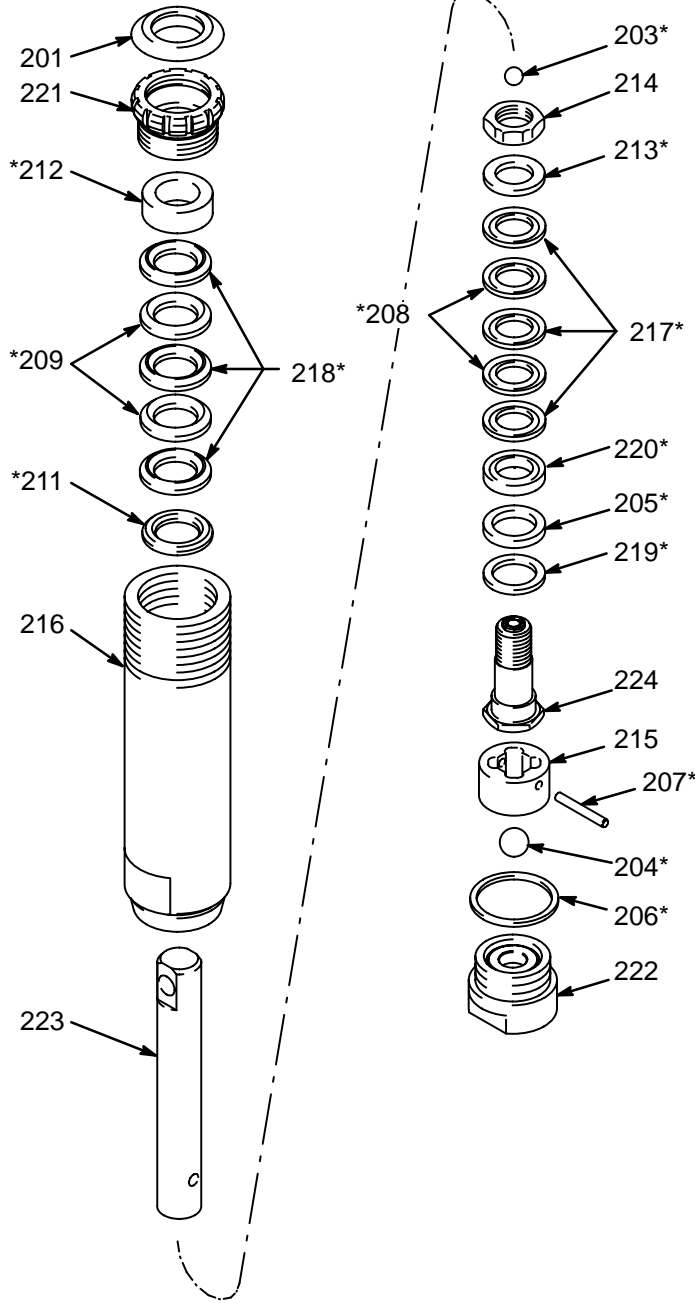

Ref No.	Part No.	Description	Qty
201	180-656	PLUG	1
203	105-444*	BALL, sst, 0.3125" dia.	1
204	105-445*	BALL, sst, 0.5" dia.	1
205	105-522*	SEAL, u-cup, polyurethane	1
206	176-761*	GASKET, brass	1
207	176-759*	PIN, ball stop	1
208	176-749*	V-PACKING, leather	2
209	176-755*	V-PACKING, leather	2
211	176-754*	GLAND, male, Delrin®	1
212	176-757*	GLAND, female, Delrin®	1
213	176-750*	GLAND, male, Delrin®	1
214	176-751	NUT, hex, 1/2-20, sst	1
215	176-760	GUIDE, ball, sst	1
216	177-929	CYLINDER, alloy steel	1
217	176-882*	V-PACKING, polyethylene	3
218	176-997*	V-PACKING, polyethylene	3
219	180-161*	WASHER, backup, aluminum	1
220	180-073*	GLAND, female, plated steel	1
221	176-758	NUT, packing/wet-cup	1
222	215-455	VALVE, intake	1
223	181-879	ROD, piston, alloy steel	1
224	218-197	VALVE, piston	1

Also included in **Repair Kit 222-587, sold separately. Keep a kit on hand to reduce down time.*

PARTS LIST – SPRAYER WITH UPRIGHT CART

Model 231–001, Series B, Basic Sprayer

Includes items 1 to 125 as listed below

Ref No.	Part No.	Description	Qty	Ref No.	Part No.	Description	Qty
1	065–099	CONDUIT, electrical	4 in.	50	215–860	PRESSURE CONTROL ASSEM-	
3	100–188	NUT, hex, 5/16–18	7	BLY			
4	100–214	LOCKWASHER, spring, 3/8"	7			<i>see parts on page 26</i>	1
7	100–057	CAPSCREW, hex hd, 5/16–18 x 3/4"	7	52	223–766	HOSE, nylon, 1/4" ID, cpld 1/4 npsm(fbe), 29" (737 mm) long, spring guard one end	1
10	162–453	NIPPLE, 1/4 npsm x 1/4 npt	1	53	215–903	BEARING ASSEMBLY	1
13	102–932	CONNECTOR, conduit, 90°	1	54	215–904	CONNECTING ROD ASSEMBLY	1
14	181–073	STRAINER	1	55	215–905	DRIVE ASSEMBLY	
18	104–008	LOCKWASHER, spring, 5/16"	2			<i>includes replacement items 55a – 55g 1</i>	
19	107–156	SCREW, mach, pan hd, 6–32 x 5/8"	6	55a	104–008	. LOCKWASHER, spring, 5/16"	2
20	105–509	CAPSCREW, soc hd, 5/16–18 x 7/8"	2	55b	106–115	. LOCKWASHER, spring, 3/8"	4
23	224–727	MOTOR, electric, 1/2 HP <i>includes replaceable items 23a–23g</i>	1	55c	100–659	. CAPSCREW, soc hd, 3/8–16 x 1"4	
23a	102–799	. TERMINAL, wire, ring <i>see page 26</i>	1	55d	100–657	. CAPSCREW, soc hd, 5/16–18 x 2"	2
23b	185–955‡	. LABEL, DANGER, English	1	55e	105–510	. LOCKWASHER, 1/4"	4
23c	596–421	. TERMINAL, wire, female, snap-on <i>see page 26</i>	4	55f	100–644	. CAPSCREW, soc hd, 1/4–20 x 3/4"	4
23d	105–771*	. CAPACITOR, motor, includes resistor	1	55g	110–293	. LUBRICANT (<i>not shown</i>)	1
23e	181–118	. LABEL, 1/2 HP	1	58	218–215	DISPLACEMENT PUMP <i>see page 27 for parts</i>	1
23f	223–597	. CIRCUIT BOARD <i>See page 26 for application information</i>	1	84	155–665	UNION, straight adapter, 3/8 npt(m) x 3/8 npsm(f) swivel	1
23g	185–952‡	. LABEL, DANGER, French	1	92	177–762‡	LABEL, warning	1
25	106–078	SCREW, flat hd, 10–24 x 3/4"	4	94	206–994	THROAT SEAL LIQUID, 8 oz. <i>not shown</i>	1
27	105–680	PIN, spring, straight, 0.167" dia x 0.94"	1	95	178–034	TAG, caution	1
29	178–597	TUBE, suction	1	97	101–242	RING, retaining	2
32	110–037	SCREW, mach, pan hd, 10–24 x 1/2"	4	99	108–179	WHEEL, semi-pneumatic	2
33	176–817	SPRING, retaining	2	100	176–884	WASHER, flat	4
34	176–818	PIN, str, hdls, 5/16" dia x 1.023"	2	110	178–341	CLIP, spring	1
35	181–062	COVER, gear box	1	112	176–762	NUT, hex, 1–1/2–18	1
36	176–824	COUPLING, pump	1	113	181–048	BRACKET, pail	1
37	176–825	GEAR, pinion	1	114	178–342	CLIP, spring	1
38	178–460	ADAPTER, 3/8 npt(m) x 1/2 npt(f)	1	115	150–513	NUT, jam, 1 7/16–20	1
40	185–524	BRACKET, mounting	1	116	100–322	WASHER, 1/4"	1
41	183–998	COVER	1	117	100–509	PLUG, 1/4–18 nptf	1
45	108–982	CONNECTOR, tube	1	118	179–945	ADAPTER, elbow, 1/4–18 npt(m) x 7/16–20	1
46	222–198	PRESSURE DRAIN VALVE <i>Includes item 45</i>	1	119	218–906	CART ASSEMBLY <i>Includes item 119a</i>	1
47	214–570	FLUID FILTER <i>Includes items 47a and 47b see 307–273 for additional parts</i>	1	119a	105–521	. PLUG, tubing	2
47a	100–040	. PLUG, pipe, 1/4 npt	1	121	101–754	PLUG, 3/8 nptf <i>see page 26</i>	1
47b	162–453	. NIPPLE, 1/4 npsm x 1/4 npt	1	125	186–495	TUBE, return	1

*Recommended spare parts.

Keep on hand to reduce down time.

‡Extra Danger and Warning labels available at no charge.

PARTS DRAWING – SPRAYER WITH UPRIGHT CART

Model 231-001, Series B
Basic Sprayer with Upright Cart

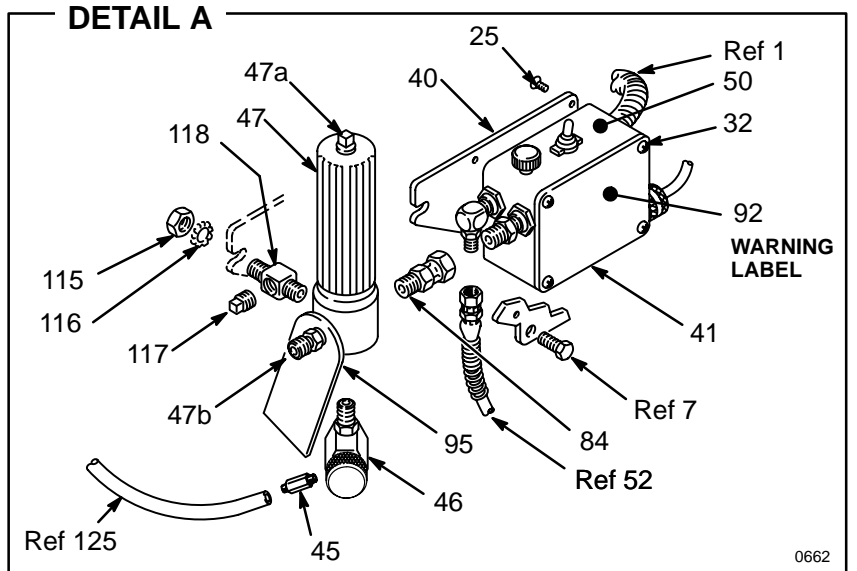
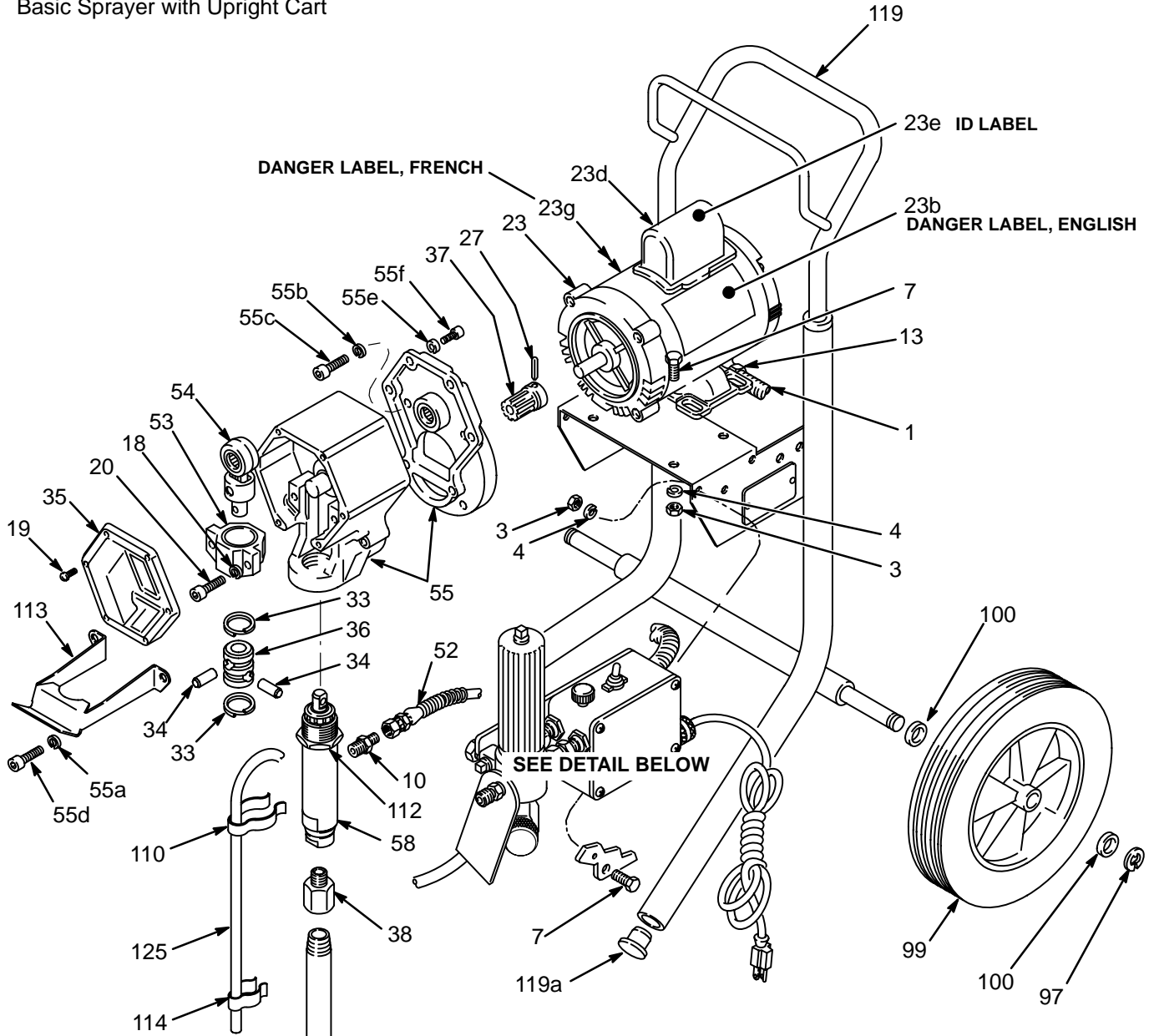

0662

PARTS LIST – SPRAYER WITH LO-BOY CART

Model 220–726, Series C, Basic Sprayer

Includes items 1 to 127 as listed below

Ref No.	Part No.	Description	Qty	Ref No.	Part No.	Description	Qty
1	065–099	CONDUIT, electrical	4 in.	52	223–767	HOSE, nylon, 1/4" ID,	
3	100–188	NUT, hex, 5/16–18	7			cpld 1/4 npsm(fbe), 21–3/4"	
4	100–214	LOCKWASHER, spring, 3/8"	7			(552 mm), spring guard one end	1
7	100–057	CAPSCREW, hex hd,		53	215–903	BEARING ASSEMBLY	1
		5/16–18 x 3/4"	7	54	215–904	CONNECTING ROD ASSEMBLY	1
10	156–823	UNION, 1/4 npt(m) x		55	215–905	DRIVE ASSEMBLY	
		1/4 npt(f) swivel	1			<i>includes replacement items 55a – 55g</i>	
13	102–932	CONNECTOR, conduit, 90°	1	55a	104–008	. LOCKWASHER, spring, 5/16"	2
14	181–073	STRAINER	1	55b	106–115	. LOCKWASHER, spring, 3/8"	2
18	104–008	LOCKWASHER, spring, 5/16"	2	55c	100–659	. CAPSCREW, soc hd, 3/8–16	
19	107–156	SCREW, mach, pan hd, 6–32				x 1"	4
		x 5/8"	6	55d	100–657	. CAPSCREW, soc hd, 5/16–18	
20	105–509	CAPSCREW, soc hd, 5/16–18				x 2"	2
		x 7/8"	2	55e	105–510	. LOCKWASHER, 1/4"	4
23	224–727	MOTOR, electric, 1/2 HP		55f	100–644	. CAPSCREW, soc hd, 1/4–20	
		<i>includes replaceable items 23a–23g</i>	1			x 3/4"	4
23a	102–799	. TERMINAL, wire, ring <i>see page 26</i>	1	55g	110–293	. LUBRICANT <i>not shown</i>	1
23b	185–955‡	. LABEL, DANGER, English	1	58	218–215	PUMP, displacement	
23c	596–421	. TERMINAL, wire, female,				<i>see page 27 for parts</i>	1
		snap–on <i>see page 26</i>	4	84	155–665	UNION, 3/8 npt(m) x	
23d	105–771*	. CAPACITOR, motor,				3/8 npsm(f) swivel	1
		<i>includes resistor</i>	1	92	177–762‡	LABEL, warning	1
23e	181–118	. LABEL, 1/2 HP	1	94	206–994	THROAT SEAL LIQUID, 8 oz.	
23f	223–597	. CIRCUIT BOARD				<i>not shown</i>	1
		<i>see page 26 for application</i>		95	178–034	TAG, caution	1
		<i>information</i>	1	99	108–179	WHEEL, semi–pneumatic	2
23g	185–952‡	. LABEL, DANGER, French	1	100	154–636	WASHER, flat	2
25	106–078	SCREW, flat hd, 10–24 x 3/4"	4	112	176–762	NUT, hex, 1 1/2–18	1
27	105–680	PIN, spring, straight,		115	150–513	NUT, jam, 7/16–20	1
		0.167" dia x 0.94"	1	116	100–322	WASHER, 1/4"	1
29	170–113	TUBE, suction	1	117	100–509	PLUG, 1/4–18 nptf	1
32	110–037	SCREW, mach, pan head,		118	179–945	ADAPTER, elbow, 7/16" stud,	
		10–24 x 1/2"	4			1/4 npt(f)	1
33	176–817	SPRING, retaining	2	119	178–342	CLIP, spring	2
34	176–818	PIN, str, hdls, 5/16" dia x 1.023"	2	120	103–927	CLAMP, hose, 1–1/4" ID	2
35	181–062	COVER, gear box	1	121	103–473	STRAP, wire, tie	2
36	176–824	COUPLING, pump	1	123	220–678	CART ASSEMBLY	
37	176–825	GEAR, pinion	1			<i>Includes item 123a and 123b</i>	1
38	183–285	ADAPTER, 3/8 npt(m) x		123a	101–242	. RING, retaining	2
		1/2 npsm (m)	1	123b	183–275	. SPACER	2
40	185–524	BRACKET, mounting	1	123c	105–521	. PLUG, tubing	2
41	183–998	COVER	1	124	176–920	HOSE, suction, 30" (762 mm)	1
45	108–982	CONNECTOR, tube	1	125	183–281	HOSE, drain	1
46	222–198	PRESSURE DRAIN VALVE		126	157–416	UNION, swivel, 90°	1
		<i>Includes item 45</i>	1	127	183–291	COUPLING, 1/2 npt x	
47	214–570	FLUID FILTER				1/2" straight pipe	1
		<i>Includes items 47a and 47b</i>					
		<i>see 307–273 for additional parts</i>	1				
47a	100–040	. PLUG, pipe, 1/4"	1				
47b	162–453	. NIPPLE, 1/4 npsm x 1/4 npt	1				
50	215–860	PRESSURE CONTROL ASSEM-					
BLY		<i>see parts on page 26</i>	1				

*Recommended spare parts.

Keep on hand to reduce down time.

‡Extra Danger and Warning labels available at no charge.

PARTS DRAWING – SPRAYER WITH LO-BOY CART

Model 220-726, Series C
Basic Sprayer with Lo-Boy Cart

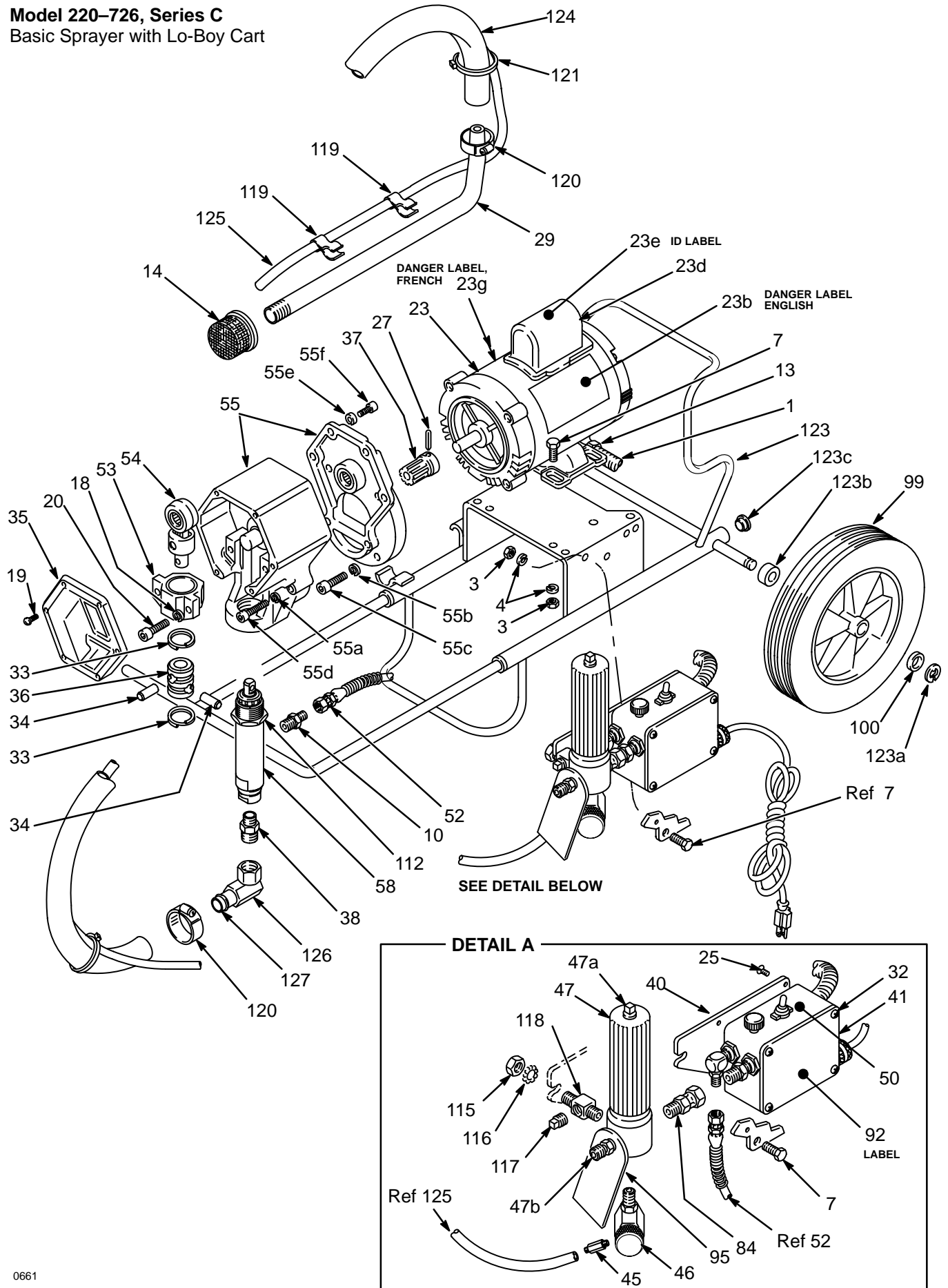

PARTS DRAWING & LIST – COMPLETE SPRAYERS

Model	Description	Ref No.	Part No.	Description	Qty
Model 231-390	Complete Upright Sprayer with Flex Gun Includes items 200 to 202, and 204	200	220-956	GUN, Flex, airless spray, see 307-633 for parts	1
		201	223-541*	HOSE, spray, cpld 1/4 npsm(fbe) swivel, 1/4" ID, nylon, 50 ft (15 m), spring guard both ends	1
Model 231-018	Complete Upright Sprayer with Contractor Gun Includes items 201, 202, 204 and 205	202	214-701*	HOSE, whip end, cpld 1/4 npt(m) x 1/4 npsm(f) swivel, 29" (740 mm) long, spring guard one end	1
		203	220-726	LO-BOY SPRAYER See parts on page 30	1
Model 231-051	Complete Lo-Boy Sprayer with Flex Gun Includes items 200 to 203	204	231-001	UPRIGHT SPRAYER See parts on page 28	1
		205	220-955	GUN, contractor, airless; see 307-614 for parts	1

**Recommended spare parts.
Keep on hand to reduce down time.*

PARTS DRAWING & LIST – COMPLETE SPRAYERS

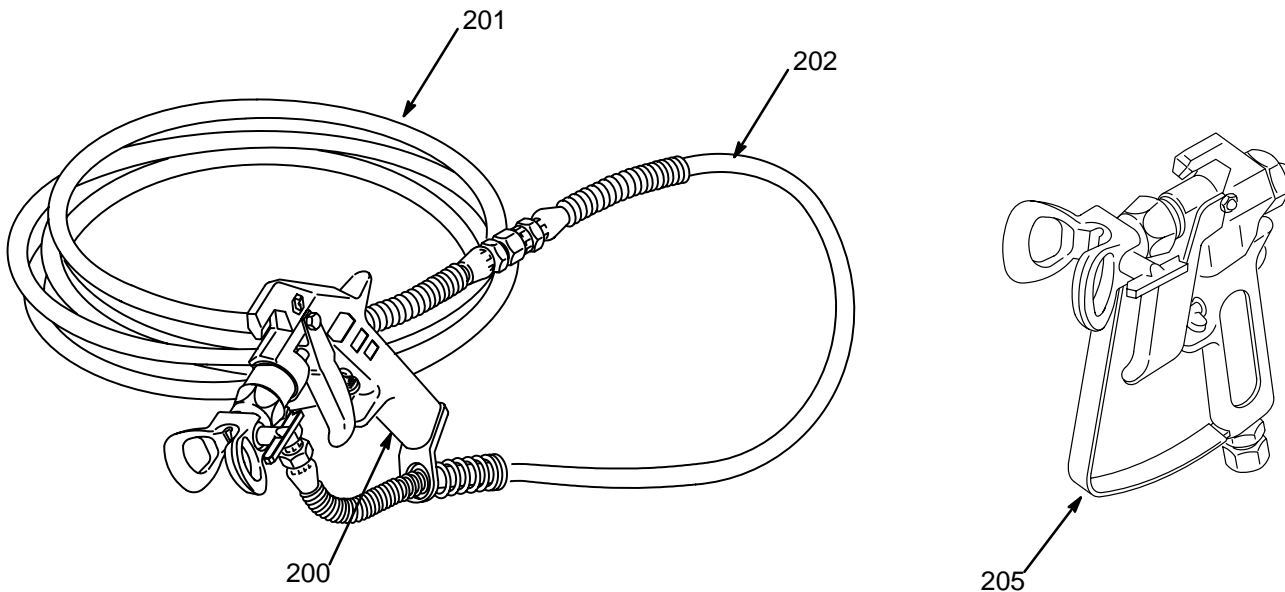

ACCESSORIES

DANGER LABELS

The English language DANGER label shown on page 1 and the same label in French is on your sprayer. If you have painters who do not read English or French, order one of the following labels to apply to your sprayer. The drawing below shows the best placement of these labels for good visibility.

Order the labels directly from Graco, free of charge. Call 1-800-328-0211

Spanish **185-961**
German **186-041**
Greek **186-045**
Korean **186-049**

Apply other
language here

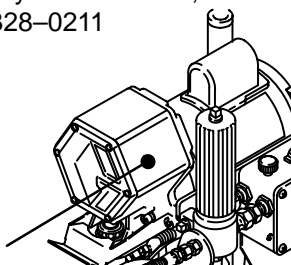

SPRAY TIP ACCESSORIES

205-264 TIP FILTER

0.005 in. spacing (equivalent to 100 mesh screen).
For stains and enamels.

205-265 TIP FILTER

0.009 in. spacing (equivalent to 60 mesh screen).
For latex.

TIP GASKETS

Provides seal between gun and spray tip.

166-969 Thin
162-863 Thick

OUTLET FILTER REPLACEMENT SCREENS

Stainless steel, 18 in.² (120 cm²)

167-025 60 mesh
167-026 100 mesh
167-027 200 mesh

THROAT SEAL LIQUID

Place in pump's wet cup to lubricate piston rod and packings.

206-994 8 oz. (0.5 liter)
206-995 1 quart (1 liter)
206-996 1 gallon (3.8 liter)
206-997 4 gallon (16 liter)

MANUAL CHANGE SUMMARY

Non-part number changes include adding the displacement pump repair and parts information (pages 18, 19 and 27) and adding Accessories (page 33).

Part number changes are listed below by the assembly changed. OLD and NEW parts are interchangeable – ADDED and DELETED parts are not. Numbers in parentheses indicate a quantity added or deleted.

Model 223-001 (only) Upright Sprayer

Part Status	Ref No.	Part No.	Name
Add (2)	100	176-884	Washer
Add	110	178-341	Clip
Add	111	186-495	Tube
Add	114	178-342	Clip
Add	45	108-982	Connector
Old	52	218-083	Hose
New	52	223-766	Hose

Model 220-726 (only) Lo-Boy Sprayer

Add (2)	55a	104-008	Lockwasher
Delete	122	801-971	Clamp
Add	122	108-982	Connector
Add	123c	105-521	Plug
Old	52	218-083	Hose
New	52	223-767	Hose

Model 223-001, Upright Sprayer AND Model 220-726, Lo-Boy Sprayer, To Rev.C

Add (1)	3	100-188	Nut
Add (1)	4	100-214	Lockwasher
Old	7	101-344	Capscrew
New (+1)	7	100-057	Capscrew
Old	23	218-949	Motor
New	23	224-727	Motor
Old	23b	178-094	Warning Label
New	23b	185-955	Danger Label
Old	23f	105-683	Circuit Board
New	23f	223-597	Circuit Board
Add	23g	185-952	Danger Label
Old	25	106-075	Screw
New	32	110-037	Screw
New	25	106-078	Screw
Old	40	181-070	Bracket
New	40	185-524	Bracket
Old	41	181-071	Cover
New	41	183-998	Cover
Old	46	210-657	Ball Valve
New	46	222-198	Drain Valve
Old	50	218-707	Pressure Ctrl
New	50	215-860	Pressure Ctrl

Models 231-390, 231-018, 231-051 Complete Sprayers

Old	201	210-541	Hose
New		223-541	Hose

TECHNICAL DATA

Maximum Working Pressure	2500 psi (172 bar)
Motor	1/2 HP, AC
Power Requirements	120V AC, 60Hz, 15 amp or 4000 Watt Generator
Extension Cord Requirements	No. 12 AWG, 3 wire, up to 200 ft (61 m)
Maximum Delivery	0.33 GPM (125 liter/min)
Cycles Per Gallon (liter)	750 (197)
Tip Size	One gun to 0.017 tip <i>with latex at 2000 psi (138 bar)</i>
Fluid Inlet	1/2 npt(m) with 30° chamfer
Fluid Outlet size	1/4 npsm(m)
Outlet Fluid Filter	60 mesh (250 micron) Stainless Steel screen, reusable
Spray Hose Requirements	Grounded, 50 ft (15 m) minimum, non-wire braid, spring guards both ends
Wetted Parts	
<i>Displacement Pump</i>	Carbon Steel, Polyurethane Polyethylene, Delrin®, Leather
<i>Filter</i>	Aluminum, Carbon Steel, Stainless Steel

NOTE: Delrin® is a registered trademark of the DuPont Co.

DIMENSIONS

Model 231-001 Upright cart without hoses or gun		Model 220-726 With lo-boy cart without hoses or gun	
Weight (dry)	70 lb (32 Kg)	Weight (dry)	70 lb (32 Kg)
Height	41 in. (1041 mm)	Height	20 in. (508 mm)
Length	20.5 in. (521 mm)	Length	31 in. (787 mm)
Width	20.5 in. (521 mm)	Width	18 in. (457 mm)

IMPORTANT PHONE NUMBERS

TO PLACE AN ORDER, contact your Graco distributor, or call this number to identify the distributor closest to you: **1-800-328-0211 Toll Free**

FOR TECHNICAL ASSISTANCE, service repair information or assistance regarding the application of Graco equipment: **1-800-543-0339 Toll Free**

TABLE OF CONTENTS

Warnings		Parts Lists and Drawings	
English	2	Pressure Control	26
French	4	Displacement pump	27
Spanish	6	Model 231-001, basic upright	28
Setup	8	Model 220-726, basic lo-boy	30
Operation	9	Model 231-390, complete upright	32
Shutdown and care	12	Model 231-018, complete upright	32
Flushing	13	Model 231-051, complete lo-boy	32
Application Methods	15	Technical Data	34
Troubleshooting	16	Accessories	34
Repair	18	Dimensions	34
		Graco Phone Numbers	34
		Warranty	36

THE GRACO WARRANTY AND DISCLAIMERS

WARRANTY

Graco warrants all equipment manufactured by it and bearing its name to be free from defects in material and workmanship on the date of sale by an authorized Graco distributor to the original purchaser for use. As purchaser's sole remedy for breach of this warranty, Graco will, for a period of twelve months from the date of sale, repair or replace any part of the equipment proven defective. This warranty applies only when the equipment is installed, operated and maintained in accordance with Graco's written recommendations.

This warranty does not cover, and Graco shall not be liable for, any malfunction, damage or wear caused by faulty installation, misapplication, abrasion, corrosion, inadequate or improper maintenance, negligence, accident, tampering, or substitution of non-Graco component parts. Nor shall Graco be liable for malfunction, damage or wear caused by the incompatibility with Graco equipment of structures, accessories, equipment or materials not supplied by Graco, or the improper design, manufacture, installation, operation or maintenance of structures, accessories, equipment or materials not supplied by Graco.

This warranty is conditioned upon the prepaid return of the equipment claimed to be defective to an authorized Graco distributor for verification of the claim. If the claimed defect is verified, Graco will repair or replace free of charge any defective parts. The equipment will be returned to the original purchaser transportation prepaid. If inspection of the equipment does not disclose any defect in material or workmanship, repairs will be made at a reasonable charge, which charges may include the costs of parts, labor and transportation.

DISCLAIMERS AND LIMITATIONS

THE TERMS OF THIS WARRANTY CONSTITUTE PURCHASER'S SOLE AND EXCLUSIVE REMEDY AND ARE IN LIEU OF ANY OTHER WARRANTIES (EXPRESS OR IMPLIED), INCLUDING WARRANTY OF MERCHANTABILITY OR WARRANTY OF FITNESS FOR A PARTICULAR PURPOSE, AND OF ANY NON-CONTRACTUAL LIABILITIES, INCLUDING PRODUCT LIABILITIES, BASED ON NEGLIGENCE OR STRICT LIABILITY. EVERY FORM OF LIABILITY FOR DIRECT, SPECIAL OR CONSEQUENTIAL DAMAGES OR LOSS IS EXPRESSLY EXCLUDED AND DENIED. IN NO CASE SHALL GRACO'S LIABILITY EXCEED THE AMOUNT OF THE PURCHASE PRICE. ANY ACTION FOR BREACH OF WARRANTY MUST BE BROUGHT WITHIN TWO (2) YEARS OF THE DATE OF SALE.

EQUIPMENT NOT COVERED BY GRACO WARRANTY

GRACO MAKES NO WARRANTY, AND DISCLAIMS ALL IMPLIED WARRANTIES OF MERCHANTABILITY AND FITNESS FOR A PARTICULAR PURPOSE, WITH RESPECT TO ACCESSORIES, EQUIPMENT, MATERIALS, OR COMPONENTS SOLD BUT NOT MANUFACTURED BY GRACO. These items sold, but not manufactured by Graco (such as electric motor, switches, hose, etc.) are subject to the warranty, if any, of their manufacturer. Graco will provide purchaser with reasonable assistance in making any claim for breach of these warranties.

Factory Branches: Atlanta, Chicago, Dallas, Detroit, Los Angeles, West Caldwell (N.J.)

Subsidiary and Affiliate Companies: Canada; England; Korea; Switzerland; France; Germany; Hong Kong; Japan

GRACO INC. P.O. BOX 1441 MINNEAPOLIS, MN 55440-1441

PRINTED IN U.S.A. 307-724 3-85 Revised 8-91

- Upright Cart — Model 231-001, Basic Sprayer
Model 231-390, Complete Sprayer*
- LoBoy Cart — Model 220-726, Basic Sprayer
Model 231-051, Complete Sprayer*

Model 231-390 shown

* Complete sprayers include 50 ft (15 m) 1/4 in. I.D. hose, 3 ft (0.9 m) 3/16 in. I.D. whip hose, and Flex gun with RAC IV DripLess™ Tip Guard and 517 SwitchTip™.

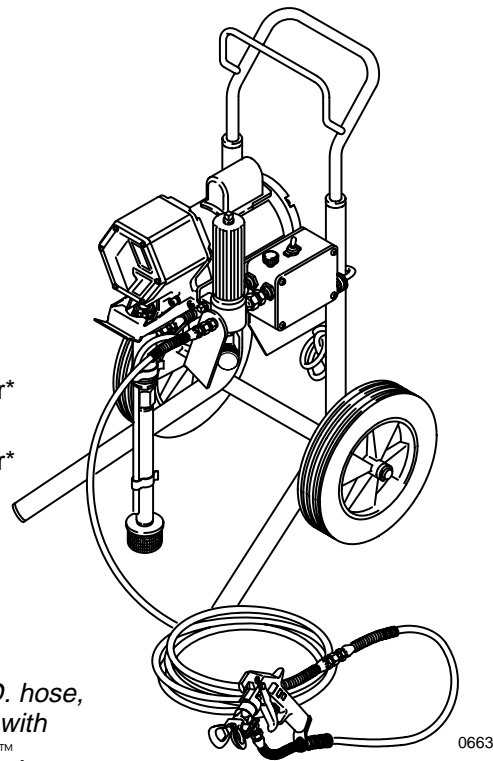

Technical Data

Maximum Working Pressure 2500 psi (172 bar)
Electric Motor 1/2 HP, AC
Power Requirements 120 VAC, 60 Hz, 15 amp or
4000 watt generator
Delivery 0.33 gpm (1.25 lpm)
Cycles Per Gallon (liter) 750 (197)
Tip Size one gun to 0.017 inch tip
with latex at 2000 psi (138 bar)
Fluid Inlet 1/2 npt(m) with 30° inside chamfer
Inlet Paint Strainer 16 mesh (1190 micron)
reusable stainless steel screen
Fluid Filter Outlet Size 1/4 npsm(m)
Fluid Filter Material aluminum, stainless steel,
carbon steel
60 mesh (250 micron) reusable SST screen
Spray Hose Requirements grounded,
50 ft (15 m) minimum, non-wire braid,
spring guards on both ends
Pump Material . . . carbon steel, polyurethane, Delrin®
Pump Packing Material UHMWPE, leather

Application

Sprays stains, lacquers, oil base, or latex. **Do not** use with solvents such as methylene chloride or other HHCs.

U.S. patent number 4,323,741.

Dimensions

	Upright	LoBoy
Height	41 in. (1041 mm)	20 in (508 mm)
Length	20.5 in. (521 mm)	31 in. (787 mm)
Width	20.5 in. (521 mm)	18 in. (457 mm)
Weight	75 lb (34 kg)	75 lb (34 kg)



GRACO INC. P.O. BOX 1441
MINNEAPOLIS, MN 55440-1441

©COPYRIGHT 1995, GRACO INC.
PRINTED IN U.S.A. 327-724 August 1995

TO PLACE AN ORDER, call
1-800-367-4023 Toll Free

FOR TECHNICAL ASSISTANCE, call
1-800-543-0339 Toll Free

Supplement to instruction manual 307-724.

EM 390 Airless Paint Sprayer

⚠ WARNING



INJECTION HAZARD

This form is only a quick reference to the features and frequently ordered parts of this sprayer. To reduce the risk of serious injury, including fluid injection, while operating or repairing this sprayer, follow the warnings and instructions in manual 307-724.

Ref No.	Upright Part No.	LoBoy Part No.	Description
16	178-597	170-113	Suction Tube
17	181-073	Same	Strainer
18	186-495	183-281	Drain Hose
19	None	176-920	Suction Hose
20	See chart below		Circuit Board (not shown)

Model 231-001, Series B, with Upright Cart
 Model 231-051, Series C, with LoBoy Cart

Ref No.	Upright Part No.	LoBoy Part No.	Description
1	215-903	Same	Bearing Assembly
2	215-904	Same	Connecting Rod
3	215-905	Same	Drive Housing
4	176-825	Same	Pinion Gear
5	224-727	Same	Motor
6	105-771	Same	Capacitor
7	110-155	Same	Motor Fan
8▲	185-952	Same	Danger Label
9	218-906	220-678	Cart
10	215-860	Same	Pressure Control
11	214-570	Same	Fluid Filter
12	222-198	Same	Pressure Drain Valve
13	108-982	Same	Connector Tube
14	223-766	223-767	Hose
15	218-215	Same	Displacement Pump
15a	176-758	Same	Packing Nut/Wet-Cup
15b	177-929	Same	.Cylinder
15c	181-879	Same	.Piston Rod
15d	218-197	Same	.Piston Valve
15e	215-455	Same	.Intake Valve

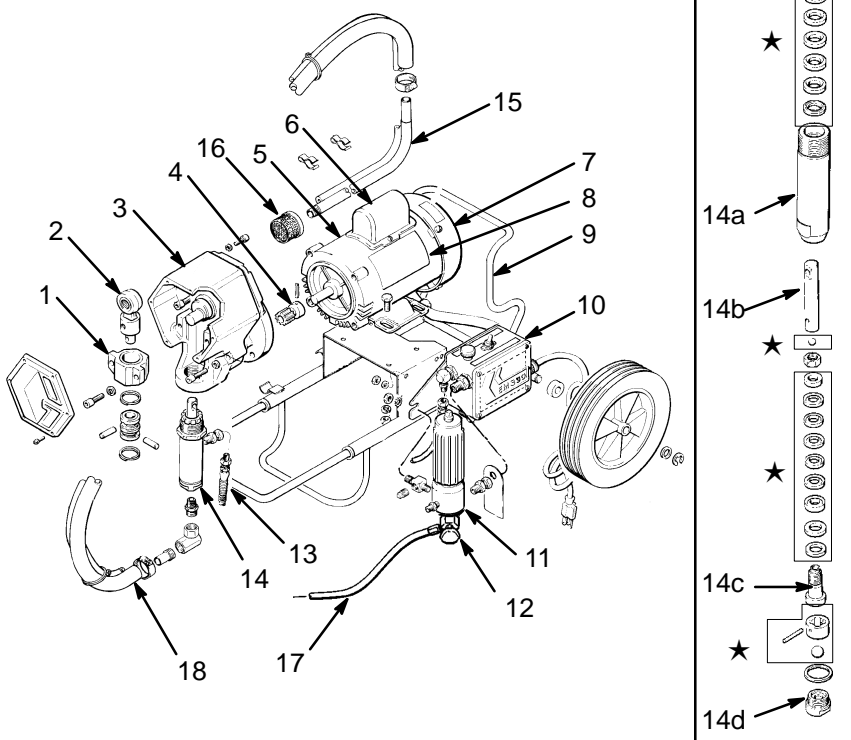
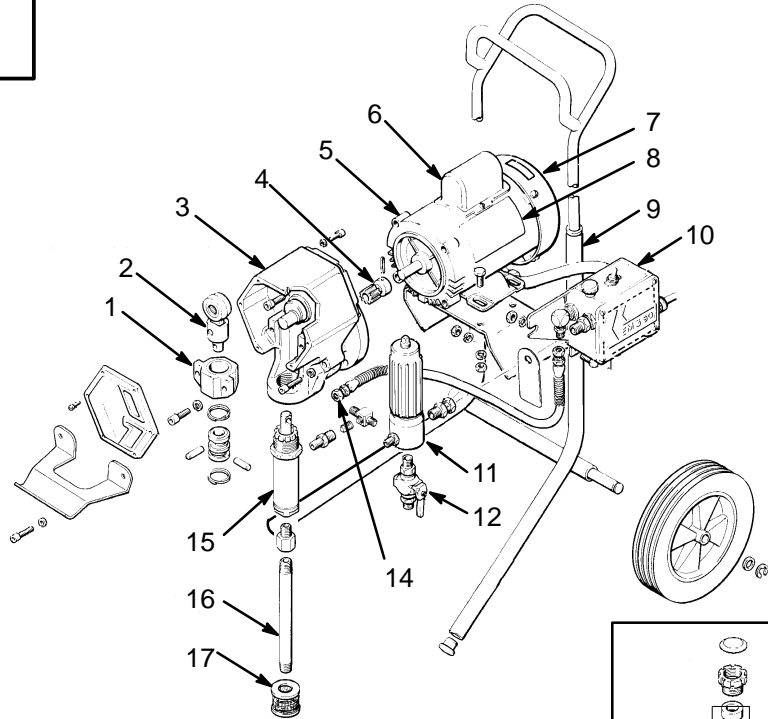

106-076 used in	Circuit Board P/N and Style	223-597 used in
220-726, A & B 231-001, A	Sprayer, Series	220-726 C & above 231-001 B & above
218-949	Graco Motor P/N	224-727
Yes	External Motor Fan	No
112125400	Franklin Motor P/N	1101007414

▲ Extra danger labels are available for free.

Packing Repair Kit 222-587
 Includes all parts marked with a ★