

# HWA Water Chillers

Installation, use and maintenance manual



**ONLY COOLING, HEAT PUMP AND FREE-COOLING  
UNITS**

**CE**

COMPANY  
WITH QUALITY SYSTEM  
CERTIFIED BY AFAQ-AFNOR  
=ISO 9001/2000=

**LENNOX**<sup>TM</sup>

## INDEX

TECHNICAL DATA	Ref. technical data label
	PAGE
<b>1 THE SERIES</b>	<b>4</b>
<b>2 FIELD OF APPLICATION</b>	<b>4</b>
<b>3 GENERALITIES</b>	<b>4</b>
<b>4 INSPECTION, CONVEYANCE, SITING</b>	<b>5</b>
4.1 INSPECTION	5
4.2 LIFTING AND CONVEYANCE	5
4.3 UNPACKING	6
4.4 SITING	6
<b>5 INSTALLATION</b>	<b>7</b>
5.1 INSTALLATION CLEARANCE REQUIREMENTS	7
5.2 GENERAL GUIDELINES FOR PLUMBING CONNECTIONS	8
5.3 WATER CONNECTION TO THE EVAPORATOR	9
5.4 INSTRUCTIONS FOR THE FILLING UP OF THE TANK	10
5.5 SAFETY VALVE DRAIN PIPES	11
<b>6 ELECTRICAL CONNECTIONS</b>	<b>11</b>
6.1 GENERALITIES	11
6.2 ELECTRIC CONNECTIONS OF FLOW SWITCH OR DIFFERENTIAL WATER PRESSURE SWITCH	12
6.3 ELECTRIC CONNECTIONS OF THE CIRCULATION PUMP	12
6.4 REMOTE CONTROLS	12
6.5 REMOTE SUMMER-WINTER SWITCHING	12
<b>7 STARTING UP</b>	<b>12</b>
7.1 PRELIMINARY CHECKS	12
7.2 STARTING OPERATION	13
7.3 CHECKS DURING OPERATION	14
7.4 CHECKING THE REFRIGERANT LEVEL	14
7.5 STOPPING THE UNIT	15
<b>8 OPERATING LIMITS</b>	<b>16</b>
8.1 WATER FLOW TO EVAPORATOR	16
8.2 CHILLED WATER TEMPERATURES	16
8.3 OUTDOOR AIR TEMPERATURE	16
8.4 OPERATION WITH WATER AT LOW TEMPERATURES	16
8.5 FREE COOLING VERSION HWA-F	17
<b>9 CONTROL DEVICE SETTINGS</b>	<b>21</b>
9.1 GENERALITIES	21
9.2 MAXIMUM PRESSURE SWITCH	23

9.3	MINIMUM PRESSURE SWITCH	23
9.4	SERVICE THERMOSTAT	23
9.5	ANTIFREEZE THERMOSTAT	23
9.6	ANTI-RECYCLE TIMER	23
9.7	OIL DIFFERENTIAL PRESSURE SWITCH	24
<b>10</b>	<b>ROUTINE MAINTENANCE AND CHECKS</b>	<b>24</b>
10.1	WARNINGS	24
10.2	GENERALITIES	25
10.3	REPAIRING THE COOLING CIRCUIT	25
10.4	TIGHTNESS TEST	25
10.5	HARD VACUUM AND DRYING OF THE COOLING CIRCUIT	26
10.6	CHARGING WITH R407C REFRIGERANT	26
10.7	ENVIRONMENTAL PROTECTION	27
<b>11</b>	<b>RETIRING THE UNIT</b>	<b>27</b>
<b>12</b>	<b>TROUBLESHOOTING</b>	<b>27</b>
<b>13</b>	<b>WATER PRESSURE DROPS</b>	<b>31</b>
13.1	EVAPORATOR PRESSURE DROPS	31
13.2	RECUPERATOR PRESSURE DROPS	31
13.3	FREE COOLING COILS PRESSURE DROPS	32
13.4	WEIGHTS SUMMARIZING TABLES	32
13.4.1	TOTAL WEIGHTS STD C-H-F	33
13.4.2	HYDRONIC MODULES WEIGHTS C-H	35
13.4.3	HYDRONIC MODULES WEIGHTS F	37
13.5	WATER PUMPING AND STORAGE SYSTEMS	39



## Declaration of conformity

Hiref S.p.A., whose main office is at n°31/33 Viale Spagna, Tribano (Pd) - Italy, hereby declares, under its sole responsibility, that the HWA water chillers, CS-CL only cooling, HS-HL with heat pump and FS-FL with free-cooling, devices for air conditioning systems, conform to the specifications of EEC Directives 73/23, 89/392, 91/368, 93/44, 93/68, 97/23, 89/336.

Tribano li, 05/04/2006

Luiqi Galletti President



## 1 THE SERIES

The group series includes:

- Chillers with fluid and heat pump HWA CS-CL-HS-HL, which cover a power range from 44.8 to 304.9 kW
- Chillers with liquid HWA FS-FL, which cover a power range from 46.2 to 301.2 kW

## 2 FIELD OF APPLICATION

These machines are designed to cool-heat water and solutions containing up to 30% glycol (percentage by weight) in civil, industrial and technological air-conditioning systems.

They must be used in observance of the operating limits specified in this manual; failure to comply with said limits will invalidate the warranties provided in the contract of sale.

## 3 GENERALITIES

- When installing or servicing the chiller, you must strictly follow the rules provided in this manual, comply with the directions on the units and take all such precautions as are necessary.
- The fluids under pressure in the cooling circuit and the presence of electrical components may cause hazardous situations during installation and maintenance work.



**Therefore, only qualified personnel may perform any kind of work on the unit.**

**ONLY QUALIFIED PERSONNEL MAY EXECUTE THE FIRST START-UP OF THE UNIT AND IT IS NECESSARY THE AUTHORIZATION BY GALLETTI S.P.A. (SEE ATTACHMENT)**

- Failure to comply with the rules provided in this manual or any modification made to the unit without prior authorisation will result in the immediate invalidation of the warranty.



**Warning: Before performing any kind of work on the unit, make sure it has been disconnected from the power supply.**

## 4 INSPECTION, CONVEYANCE, SITING

### 4.1 INSPECTION

On receiving the unit, check that it is perfectly intact: the machine left the factory in perfect conditions; immediately report any signs of damage to the carrier and note them on the Delivery Slip before signing it.

Galletti S.p.A. or its Agent must be promptly notified of the entity of the damage.

The Customer must submit a written report describing every significant sign of damage.

- Starting operation ratio,
- Electric pattern,
- Certificate of warranty and list of assistance centres,
- Check integrity of this user manual.

### 4.2 LIFTING AND CONVEYANCE

While the unit is being unloaded and positioned, utmost care must be taken to avoid abrupt or violent manoeuvres. The unit must be handled carefully and gently: avoid using machine components as anchorages when lifting or moving it.

The unit must be lifted using steel pipes of  $\text{Ø}1\frac{1}{2}$ " GAS with depth at least 3mm inserted through the eyebolts provided on the base frame (see fig. below) and check off with appropriate stickers. The pipes which must run at least 300mm out of each side should be harnessed with rope all equal and ensured to the uplift hook (firms at pipes ends are necessary to avoid that, because of the unit weight, the rope run away from the pipe itself).

Use ropes or belts of adequate length (longer than the unit height) and spacer bars put on the unit top to avoid damaging the sides and top of the unit itself.



**Warning: In all lifting operations make sure that the unit is securely anchored in order to prevent accidental falls or overturning.**

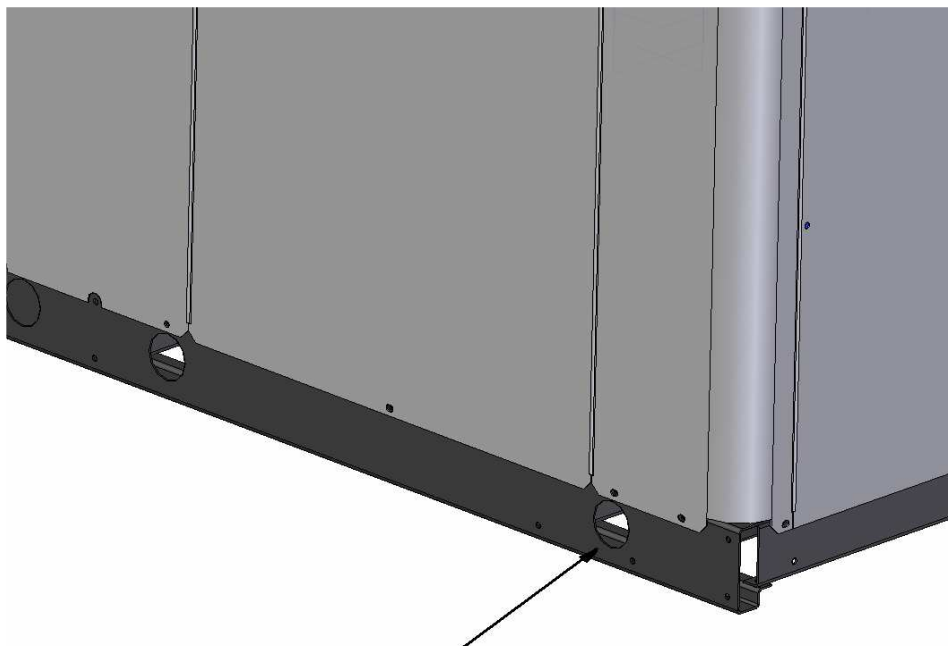

### 4.3 UNPACKING

The packing must be carefully removed to avoid the risk of damaging the unit. Different packing materials are used: wood, cardboard, nylon etc.

It is recommended to keep them separately and deliver them to suitable waste disposal or recycling facilities in order to minimise their environmental impact.

*Inside the unit, if provided with pump/s and/or tank, you'll find the expansion pot packed, and you have to fix it on the suction pipes of the pump, in which you can find a "TEE" tight-fixed, or on the tank itself. Remove the top and screw down the expansion pot (only made by qualified personnel) before filling the circuit with water and starting up the unit.*

### 4.4 SITING

You should bear in mind the following aspects when choosing the best site for installing the unit and the relative connections:

- size and origin of water pipes;
- location of power supply;
- accessibility for maintenance or repairs;
- solidity of the supporting surface;
- ventilation of the air-cooled condenser and necessary clearance;
- direction of prevalent winds: avoid positioning the unit in such a way that the prevalent winds favour the backflow of air to the condenser coils; a speed of 8 m/s (28.8 km/h) already generates a sufficient stagnation pressure to guarantee 60% of the nominal air flow rate.[In situations where the action of air currents is inevitable and there is a simultaneous presence of temperatures below - 5°C, the control of condensation for low outdoor temperatures must be of the flooding type or with a device for choking the condensing exchanger -contact the technical department for further details]
- possible reverberation of sound waves.

All models belonging to the HWA series are designed and built for outdoor installation: avoid covering them with roof structures or positioning them near plants (even if they only partly cover the unit) which may interfere with the regular ventilation of the unit condenser.

It is a good idea to create a base of adequate dimensions to support the unit. This precaution becomes essential when the unit is to be sited on unstable ground (various types of soil, gardens, etc.).

It is advisable to place a rigid rubber strip between the base frame and the supporting surface.

Whenever more effective insulation is required, it is recommended to use vibrating-damping spring supports.

In the case of installation on roofs or intermediate storeys, the unit and pipes must be insulated from walls and ceilings by placing rigid rubber joints in between and using supports that are not rigidly anchored to the walls.

If the unit is to be installed in proximity to private offices, bedrooms or areas where noise levels must be kept down, it is advisable to conduct a thorough analysis of the sound field generated and verify its compatibility with the local laws in force.

## 5 INSTALLATION

### 5.1 INSTALLATION CLEARANCE REQUIREMENTS

It is of fundamental importance to ensure an adequate volume of air both on the intake and outlet sides of the condenser coils; it is highly important to prevent the air delivered from being re-aspirated as this may impair the performance of the unit or even cause an interruption in normal operation. For this reason it is necessary to guarantee the following clearances (see figure on this page):

- rear side/plumbing connections: min. 1.5 metres to guarantee access to plumbing connections and/or for any necessary maintenance on the pumps, reservoir, expansion tank and flow switch.
- electric control board side: min. 1.5 metres to guarantee access for inspection and/or maintenance of cooling components
- coil side: min. 1.5 metres to ensure proper air circulation and access to the compressor compartment, also from the side.
- top side: there must be no obstacle to expulsion.

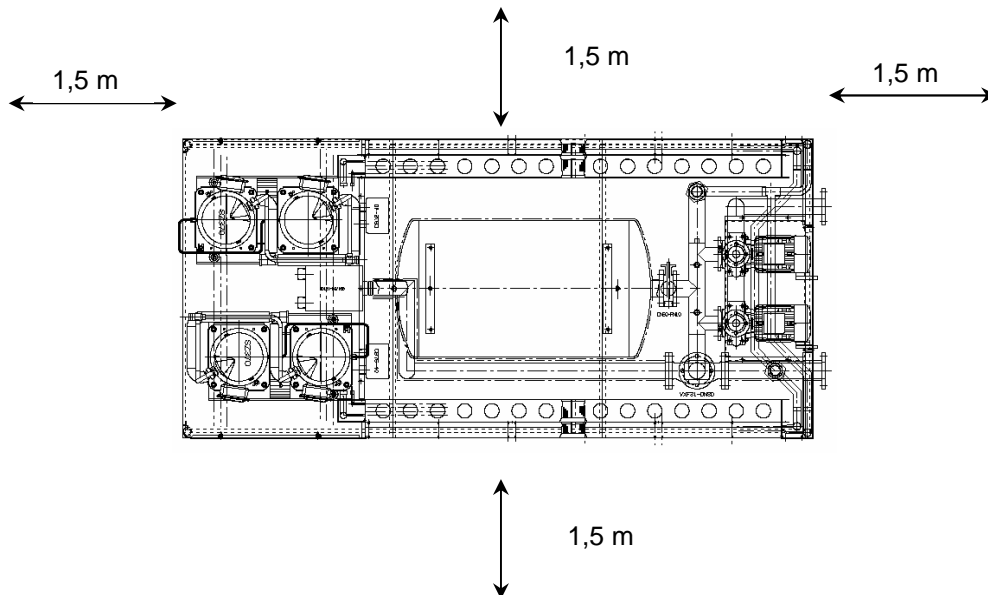

## 5.2 GENERAL GUIDELINES FOR PLUMBING CONNECTIONS

When you are getting ready to set up the water circuit for the evaporator you should follow the directions below and in any case make sure you comply with national or local regulations (use the diagrams included in this manual as your reference).

- Connect the pipes to the chiller using flexible couplings to prevent the transmission of vibrations and to compensate thermal expansions.
- It is recommended to install the following components on the pipes:
  - temperature and pressure indicators for routine maintenance and monitoring of the unit. Checking the pressure on the water side will enable you to verify whether the expansion tank is working efficiently and to promptly detect any water leaks within the equipment.
  - traps on incoming and outgoing pipes for temperature measurements, which can provide a direct reading of the operating temperatures. Temperature readings can in any case be obtained from the microprocessor installed on the unit.
  - regulating valves (gate valves) for isolating the unit from the water circuit.
  - metal mesh filter (incoming pipes), with a mesh not to exceed 1 mm, to protect the exchanger from scale or impurities present in the pipes.
  - air vent valves, to be placed at the highest points of the water circuit for the purpose of bleeding air. [The internal pipes of the unit are fitted with small air vent valves for bleeding the unit itself: **this operation may only be carried out when the unit is disconnected from the power supply – mainly on Free-Cooling units be sure that the circuit is completely full of water, than clean the water coils from air to avoid cavitation events of the pump itself**].
  - drainage valve and, where necessary, a drainage tank for emptying out the equipment for maintenance purposes or when the unit is taken out of service at the end of the season. [A 1" drainage valve is provided on the optional water storage reservoir: **this operation may only be carried out when the unit is disconnected from the power supply**]
  - It is necessary to use glycolic solutions on FS-FL units (max. 30% of weight) to prevent hardly reparable damages at the finned coil caused by freezing of the coil itself. Check carefully the minimum air T which the unit could be exposed to and consequently define the % of antifreeze to add.



If you don't use antifreeze solutions you may cause serious damages to the freecooling coils and in general to the hydraulic / cooling circuit.



### 5.3 WATER CONNECTION TO THE EVAPORATOR



It is of fundamental importance that the incoming water supply is hooked up to the connection marked "Water Inlet"

Otherwise the evaporator would be exposed to the risk of freezing since the antifreeze thermostat would not be able to perform its function; moreover the reverse cycle would not be respected in the cooling mode, resulting in additional risks of malfunctioning

The dimensions and position of plumbing connections are shown in the dimension tables at the back of the manual.



The water circuit must be set up in such a way as to guarantee that the nominal flow rate of the water supplied to the evaporator remains constant (+/- 15%) in all operating conditions.

The compressors often work intermittently, since the chilling requirements of the user generally do not coincide with the compressor output. In systems containing little water, where the thermal inertia of the water itself is lower, it is a good idea to check that the water content in the section delivering to users satisfies the condition below:

$$V = \frac{Cc \times \Delta\tau}{\rho \times Sh \times \Delta T \times Ns}$$

V	= water content in user section	[m <sup>3</sup> ]
Sh	= specific heat of the fluid	[J/(kg/°C)]
ρ	= fluid density	[kg/m <sup>3</sup> ]
Dτ	= minimum time lapse between 2 compressor restarts	[s]
DT	= allowed water T differential	[°C]
Cc	= Cooling capacity	[W]
Ns	= N° of choking steps	

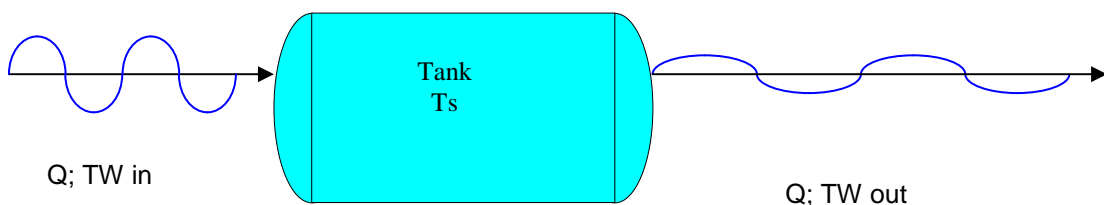

A **standard** feature of HWA / HWA-F units is a device for controlling the flow rate (flow switch or differential pressure switch) in the water circuit in the immediate vicinity of the evaporator. Frame 3, 4, 5 units include a blade-type flow switch positioned in the ventilation compartment.



Any tampering with said device will immediately invalidate the warranty.

It is advisable to install a metal mesh filter on the inlet water pipe.



It is strongly recommended to install a safety valve in the water circuit. In the event of serious equipment faults (e.g. fire) it will enable water to be drained from the system, thereby preventing possible bursts. Always connect the drain outlet to a pipe with a diameter at least as large as that of the valve opening and direct it toward an area where the discharge of water cannot harm people. This is a standard feature of units equipped with the optional storage reservoir.



Warning: When making the plumbing connections, make sure there are no open flames in proximity to or inside the unit.

#### 5.4 INSTRUCTIONS FOR THE FILLING UP OF THE TANK



The tank is not planned to resist to a depression greater than -0,15 Bar, so pay attention to the fact that the suction pressure of the pump, where the expansion tank is positioned, has to be always greater than 0,5 Bar with the pump in operation: this fact also contributes to reduce any risks concerning the cavitation of the pump.

It is of fundamental importance for the installer to follow and check the instructions written below stepwise, so as to avoid every kind of risks concerning the implosion of the tank or the cavitation of the pump:

- a) Empty the expansion tank until the pressure is 0,5 Bar
- b) Charge the system and pressurize it until about + 1 Bar in suction, pump side (with pump not working)
- c) Allow air to escape from the system
- d) Check the suction pressure of the pump (about 1 Bar) and start the system
- e) Stop the pump after 15-30 minutes and repeat from point **c**) until you don't hear noises, caused by air still present in the system, anymore.

## 5.5 SAFETY VALVE DRAIN PIPES



Safety valves are fitted in each refrigerant circuit: some regulations provide that the refrigerant drained from the valves be conveyed to the outside by means of a suitable pipe with a diameter at least matching that of the valve drainage outlet; the valve must not be made to bear the weight of the pipe. The valves positioned on the compressor outlet only discharge hot saturated gas; those on the liquid receivers, despite being positioned in the top part of the latter, may discharge saturated liquid and pose a greater hazard of burns due to the strong dehydrating effect caused by the sudden evaporation of refrigerant fluid in contact with bodies having a  $T > -41$  °C.



Warning: Always direct the drain pipe toward an area where the discharge cannot harm people.

## 6 ELECTRICAL CONNECTIONS

### 6.1 GENERALITIES



Before carrying out any job on electrical parts, make sure the power supply is disconnected.

Check that the mains electricity supply is compatible with the specifications (voltage, number of phases, frequency) shown on the unit rating plate.

The connection to the power supply should be made with a three-pole + neutral cable and earthing wire.



The size of the cable and line protections must conform to the specifications provided in the wiring diagram.

The supply voltage may not undergo fluctuations exceeding  $\pm 5\%$  and the unbalance between phases must always be below 2%.



The above operating conditions must always be complied with: failure to ensure said conditions will result in the immediate invalidation of the warranty.

The electrical connections must be made in accordance with the information shown in the wiring diagram provided with the unit and current regulations.

An earth connection is required by law. The installer must connect the earthing wire using the earthing terminal situated on the electric control board (yellow and green wire).

The power supply to the control circuit is shunted from the power line through an insulating transformer situated on the electric control board.

The control circuit is protected by suitable fuses.

## 6.2 ELECTRIC CONNECTIONS OF FLOW SWITCH OR DIFFERENTIAL WATER PRESSURE SWITCH

It is pre-wired in all HWA units. Units up to model 105 feature a differential pressure switch that detects pressure drops upstream and downstream from the evaporator (outgoing – returning water in the case of units equipped with a pump system) ; units from model 115 to model 300 have a blade-type flow switch installed in series with water circuit.

## 6.3 ELECTRIC CONNECTIONS OF THE CIRCULATION PUMP

If selected on ordering, it/they is/are supplied pre-wired with all HWA units.



The pump must be started before the chiller and stopped after the latter (minimum recommended delay: 60 seconds). If included as an option, this function is already performed by the electric control board on the unit.

## 6.4 REMOTE CONTROLS

If you wish to include a remote control for switching the unit on and off, you must remove the bridge between the contacts indicated in the wiring diagram and connect the remote ON/OFF control to the terminals themselves [see annexed wiring diagram].



All remote controls work with a very low voltage (24 Vac) supplied by the insulating transformer on the electric control board.

## 6.5 REMOTE SUMMER-WINTER SWITCHING

If you wish to include a remote control for switching the unit between the summer and winter operating modes, you must remove the bridge between the contacts indicated in the wiring diagram and connect the remote switching control to the terminals themselves [see annexed wiring diagram].

# 7 STARTING UP

## 7.1 PRELIMINARY CHECKS

- Check that all the valves in the cooling circuit are open (liquid line).
- Check that the electrical connections have been made properly and that all the terminals **are securely tightened**. This check should also be included in a periodic six-month inspection.
- Check that the voltage at the RST terminals is  $400\text{ V} \pm 5\%$  and **make sure** the yellow indicator light of the phase sequence relay is on. The phase sequence relay is positioned in the middle right part of the electric control board; if the sequence is not duly observed, it will not enable the machine to start.
- Make sure there are no refrigerant leaks that may have been caused by accidental impacts during transport and/or installation.
- Check that the crankcase heating elements are properly connected to the power supply (present on HS-HL-FS-FL units, by series).



The heating elements must be turned on at least 12 hours before the unit is started. Their function is to raise the T of the oil in the sump and limit the quantity of refrigerant dissolved in it.

To verify whether the heating elements are working properly, check the lower part of the compressors: it should be warm or in any case at a temperature 10 - 15 °C higher than the ambient temperature.

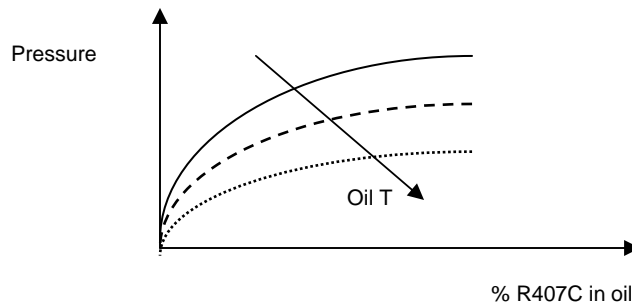

The diagram above illustrates a specific property [Charles' Law] of gases, which are more soluble in liquids as the pressure increases but less soluble as the temperature increases: if the oil in the sump is held at a constant pressure, an increase in temperature will significantly reduce the amount of refrigerant dissolved in it, thus ensuring that the lubricating function desired is maintained.

- Check that the plumbing connections have been properly made according to the indications given on the plates to be found on the unit itself (proper inlet and outlet connections).
- Make sure that the water circuit is duly bled to completely eliminate the presence of air: load the circuit gradually and open the air vent valves on the top part, which the installer should have set in place.

## 7.2 STARTING OPERATION

Before starting the chiller, turn the main switch off, select the operating mode desired from the control panel [red button = heating, green button = cooling] and press the "ON" button on the control panel.

The unit will start up if enabled:

- by the safety devices of the water circulation pump/s
- by the flow switch (or differential pressure switch)
- by the T sensor measuring the temperature of the water returning from the system [chiller inlet]
- and no alarms have been triggered

If the unit fails to start up, check whether the service thermostat has been set according to the nominal values provided



You should not disconnect the unit from the power supply during periods when it is inoperative but only when it is to be taken out of service for a prolonged period (e.g. at the end of the season). To turn off the unit temporarily follow the directions provided in the section "Stopping the Unit"

### 7.3 CHECKS DURING OPERATION

- Check the phase sequence relay on the electric panel to verify whether the phases occur in the correct sequence: if they do not, disconnect the unit from power supply and invert two phases of the incoming three-pole cable. Never attempt to modify internal electrical connections: any undue modifications will render the warranty null and void.



All the three-phase devices on the unit, compressor, water pump and fans have a set direction of rotation and were harmonized in the factory.

- Check that the temperature of the water entering the evaporator is close to the value set on the service thermostat.

### 7.4 CHECKING THE REFRIGERANT LEVEL

- After a few hours of operation, check whether the liquid level indicator has a green crown: a yellow colour indicates the presence of humidity in the circuit. In such a case the circuit must be dehumidified by qualified personnel.
- Large quantities of bubbles should not appear through the liquid level indicator. A constant passage of numerous bubbles may indicate that the refrigerant level is low and needs to be topped up. The presence of a few bubbles is however allowed, especially in the case of high-glide ternary mixtures such as HFC R407C
- A few minutes after the compressors have started up, check that the end-of-condensation temperature shown on the pressure gauge (refer to the pressure gauge scale for the refrigerant R407C, marked with the initials B.P. - Bubble Point) is about 19÷22 °C higher than the temperature of the air entering the condenser with the fans driven at top speed.
- Also check that the end-of-evaporation temperature shown on the pressure gauge (refer to the pressure gauge scale for the refrigerant R407C, marked with the initials D.P. - Dew Point) is about 5÷6 °C lower than the temperature of the water leaving the evaporator.
- Make sure the overheating of the cooling fluid is limited to between 5 and 8 °C: to this end:
  - 1) read the temperature indicated by a contact thermometer placed on the compressor intake pipe;
  - 2) read the temperature indicated on the scale of a pressure gauge likewise connected to the intake side; refer to the pressure gauge scale for the refrigerant R407C, marked with the initials D.P. (Dew Point).The degree of overheating is given by the difference between the temperatures thus determined.
- Make sure that the undercooling of the cooling fluid is limited to between 4 and 6°C: to this end:
  - 1) read the temperature indicated by a contact thermometer placed on the condenser outlet pipe;
  - 2) read the temperature indicated on the scale of a pressure gauge connected to the liquid inlet at the condenser outlet; refer to the pressure gauge scale for the refrigerant R407C, marked with the initials B.P. (Bubble Point).

The degree of undercooling is given by the difference between the temperatures thus determined.



Warning: all HWA units are charged with R407C: any top-ups must be made by specialised personnel using the same type of refrigerant, exclusively in the liquid phase.



Warning: the refrigerant R407C requires "POE" polyolester oil of a type approved by the compressor manufacturer.  
For no reason should a mineral oil be introduced into the oil circuit.

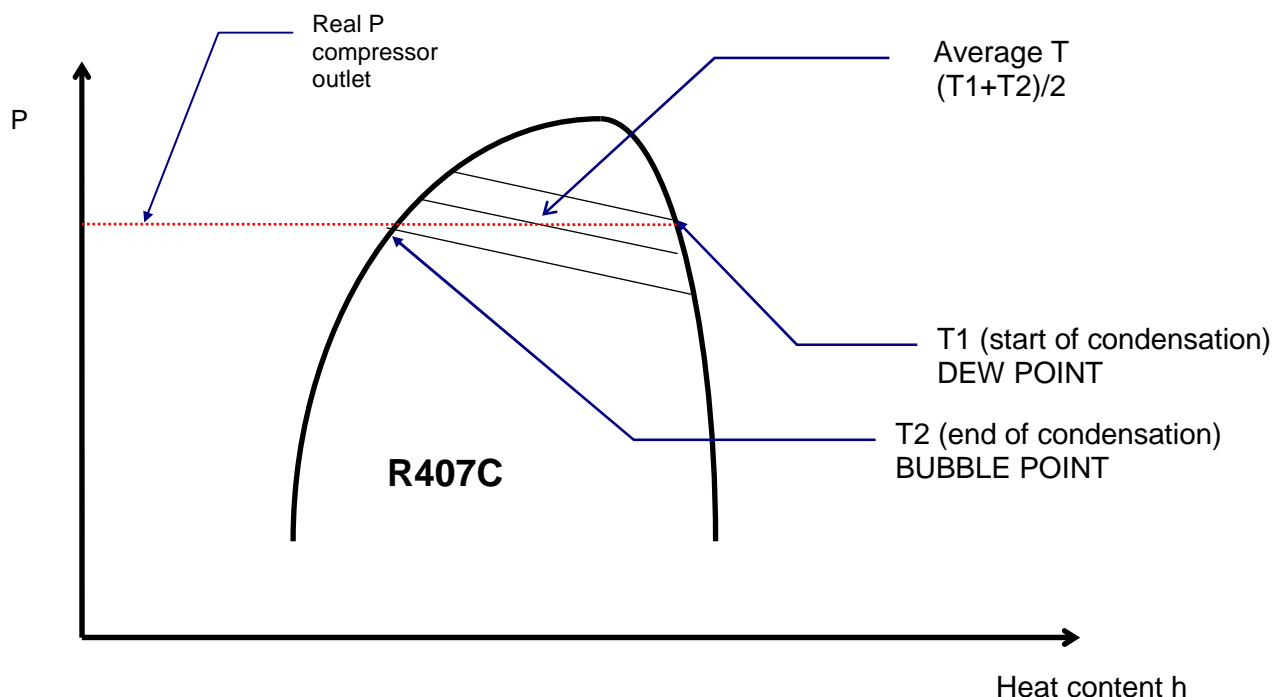

- The difference between the Dew Point and Bubble Point is known as "GLIDE" and this is a characteristic property of refrigerant mixtures. If pure fluids are used, the phase change occurs at a constant T and thus the glide is equal to zero.

## 7.5 STOPPING THE UNIT

To stop the unit press the "OFF" unit on the front panel.



Warning: do not stop the unit using the main switch: the latter device serves to disconnect the unit from the electricity supply when there is no passage of current, i.e. when the unit is already turned OFF.  
Moreover, if you completely disconnect the unit from the electricity supply, the crankcase heating elements will receive no power, thereby jeopardising the integrity of the compressor the next time the unit is started.

## 8 OPERATING LIMITS

Operating limits of HWA chillers in relation to the outlet water temperature and outdoor air temperature:

	Min.	Max.
<b>Temperature of water leaving evaporator [°C]:</b>	<b>5 (30)</b>	<b>12 (45)</b>
<b>Outdoor air temperature [°C]:</b>	<b>-10</b>	<b>45</b>

### 8.1 WATER FLOW TO EVAPORATOR

The nominal flow rate is based on a thermal differential of 5° C between inlet and outlet water, in relation to the cooling capacity provided at the nominal water (12/7 °C) and air (35°C) temperatures.

The maximum allowed flow rate is associated with a thermal differential of 3 °C: higher flow rates, though admissible, cause pointless, high drops in pressure.

The minimum allowed flow rate is associated with a thermal differential of 8 °C or a minimum pressure drop of 10 kPa: lower flow rates cause a reduction in heat exchange coefficients and excessively low evaporation temperatures, which may trigger the safety devices and cause the unit to stop.

### 8.2 CHILLED WATER TEMPERATURES

The minimum temperature of the water leaving the evaporator is 5 °C: lower temperatures are possible, but for such applications the Manufacturer should be consulted at the time the order is placed.

The maximum temperature of the water entering the evaporator is 20 °C. To allow higher temperatures specific equipment solutions must be adapted (split circuits, three-way valves, bypasses, storage reservoirs): contact the Manufacturer.

### 8.3 OUTDOOR AIR TEMPERATURE

The units are designed and built to work with outdoor temperatures ranging from -10 (with condensation control) to 45 °C. Contact the Manufacturer in the event of outdoor temperatures beyond this range.

On request, the units may be equipped with an electric heating element serving to heat the evaporator in cases where the unit is exposed to rigid temperatures during wintertime periods of quiescence.

The heating element is activated whenever the temperature of the water leaving the evaporator falls below the temperature set on the antifreeze heating element.

### 8.4 OPERATION WITH WATER AT LOW TEMPERATURES



The standard units are not designed to work with chilled water temperatures below 5 °C at the evaporator outlet. In order to work below this limit, the unit requires specific technical adjustments: in such cases contact the Manufacturer.



### 8.5 FREE COOLING VERSION HWA-F

Free Cooling units are only in cooling execution and it's not possible to link this execution with the heat pump one. The series of these units, because of the particular application type, is equipped with a condensation pressure control device and microprocessor ADVANCED control.

The following picture shows the normal field of application of free cooling units.

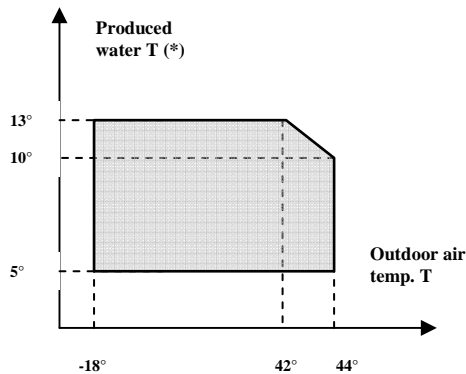

The inferior limit is dew to the freezing temperature limitation of glycolated solutions of 35% of glycol weight, that is the maximum value possible for the tightness of the pumps in use. On demand, special ceramic tights of the pumps are available to allow the employment with T lower than the listed ones (use of glycol in % up to 50 % of weight).

<b>Produced water min. temperature °C</b>	5	2	-1	-5	-10
<b>Etilenic glycol weight steel %</b>	0 %	10 %	15%	25 %	30 %
<b>Blend freezing temperature</b>	0	-4	-8	-14	-18

The series of free cooling units is provided with the heaters of the compressor oil sump. The picture below fig. "Oil" shows the characteristic [Charles' law] for gases that melt in a liquid in greater volumes as well as the pressure and the contemporary temperature opposition action are higher: on equal pressure in the sump, an oil temperature increase reduces the melt refrigerant volume sensibly so that you could obtain the maintenance of the desired lubrication characteristics. The problem of insufficient lubrication, when a suitable heating of the carter is absent, occurs mainly after stops during which, because of the lift compressor, there occurs a sudden pressure droop in the sump and consequently a strong evaporation of the refrigerant melt before in the oil. This event, when there are no heatings, could cause 2 problems:

- ❑ oil dilution than insufficient lubrication
- ❑ oil migration towards the cooling circuit because of the dragging of the refrigerant.

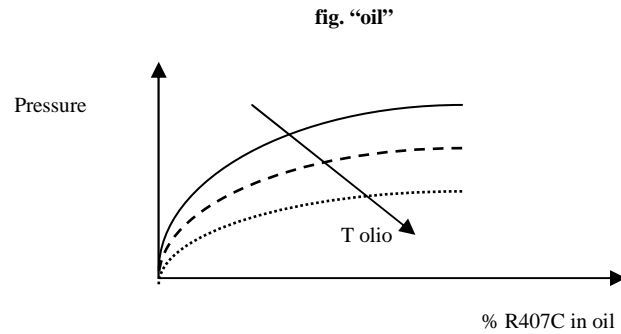

Using the heaters is important mainly during the first starting up of the unit, and it is better to switch them on at least 12 hours before starting the compressors up.

If outdoor air T decreases a lot, the system water T control is warranted by the modulating action of the fans and, in the negative (strong dominant winds), by the 3-way valve lock. Only on demand, for borderline cases, the modulating joint action by the 3-way valve is available.

#### Cooling circuit in Free Cooling units

In addition to above-written, Free Cooling units are provided with a 3-way valve able to deviate the flow towards the Free Cooling coils, that are put upstream, compared with the condensing ones, in the air flow. The valve activation is controlled by microprocessor (ADVANCED on series) that check the difference between the set-point T of water coming back from the user (T1) and outdoor air (T2). **[fig. 5]**

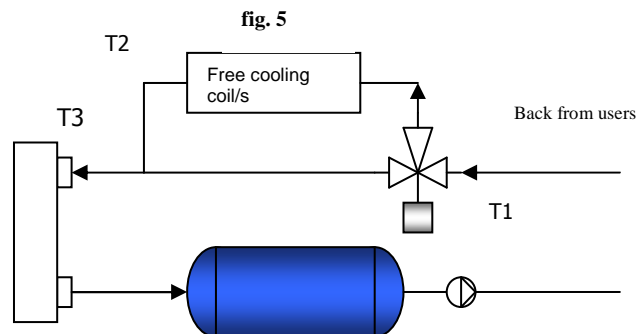

The probe put at the evaporator input (T3) than pilots the compressors starting up in integration in the event that the free cooling performance is not sufficient to cover the whole thermal requirements. The temperatures T1 and T3 are always controlled by the microprocessor on board to verify possible anomalies of the free cooling 3-way valve: for example, if you have free cooling phase, so with exchanged valve, but T1 and T3 are equal, it means that the valve is blocked; in case of free cooling anomalies, you can decide to produce only an alarm or to force the unit in power off.

The 3-way valve is also predisposed to manual positioning if there are some anomalies in the service servo-motor: in the following picture you can see the positioning of the 3-way valve

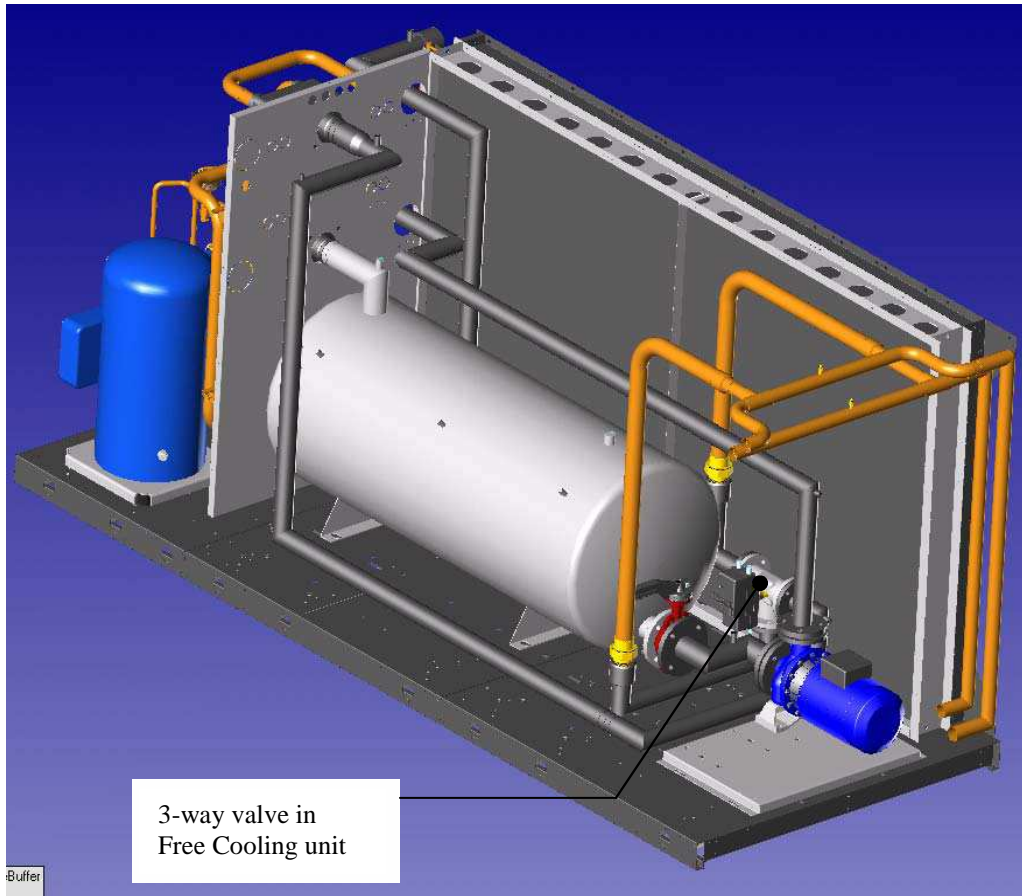

which you can have access to removing the cap shown in the following picture, for manual activation.

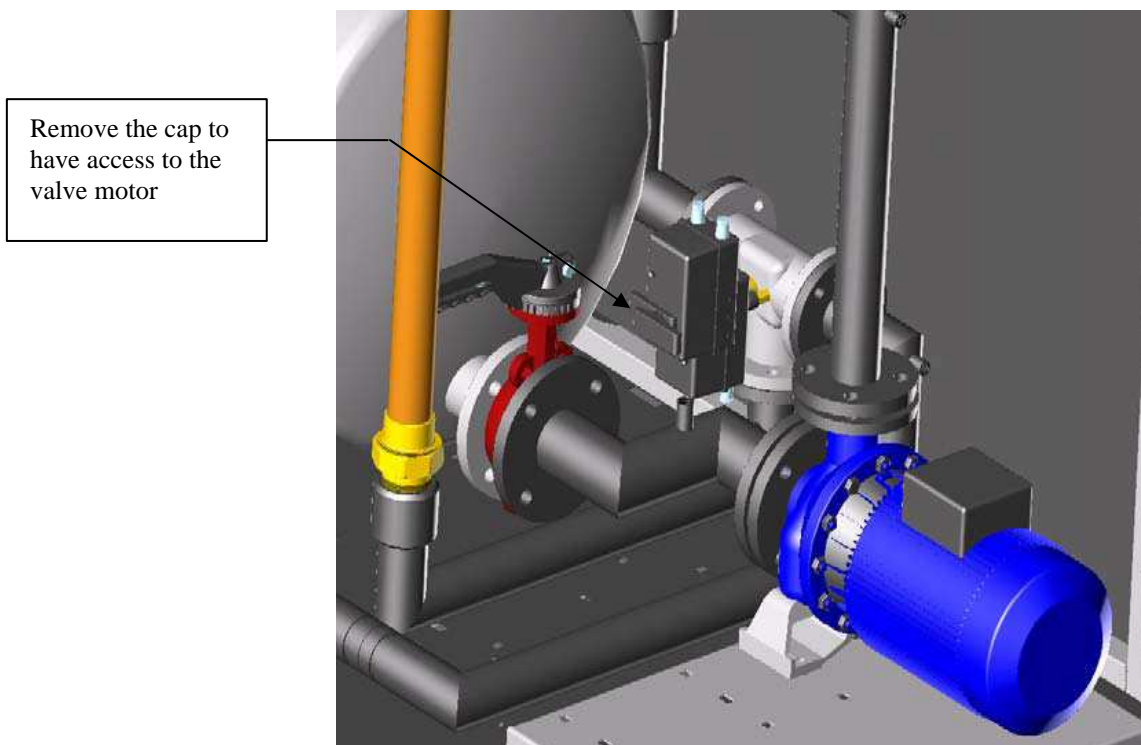

The free cooling execution allows a very great energy saving in all those situations in which the outdoor temperature is lower than the temperature of the circulating flow (process industry, close control applications, information technology in general, convention halls, etc.). The free cooling circuit performance depends on the difference between the outdoor air T and the circulating water T, as shown in the picture **fig. 6**

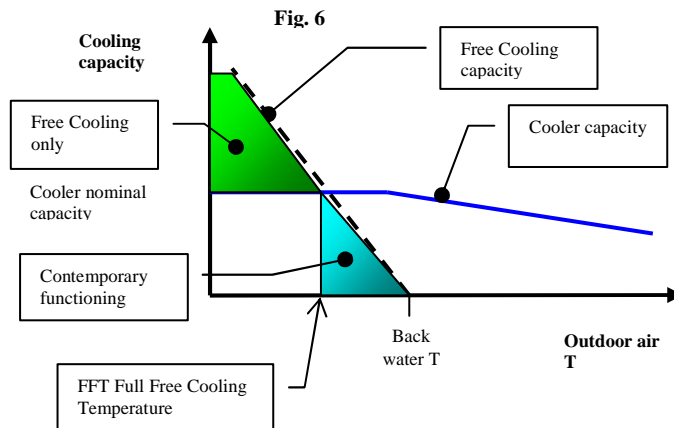

when the outdoor air  $T_2$  decrease below the water  $T_1$  back from the user, it is possible to have thermal exchange and so free cooling action starts with a possible integration of one or more steps mechanical cooling. During this phase it is important to have the maximum air flow so that the free cooling coils capacity is maximized, and so as to have at the same time an effective control of the condensing pressure, the condensing coils are provided with a special partialization circuit that reduces their thermal exchange surfaces allowing in this way the unit to work with maximum air flow (fig.7)

**fig. 7**

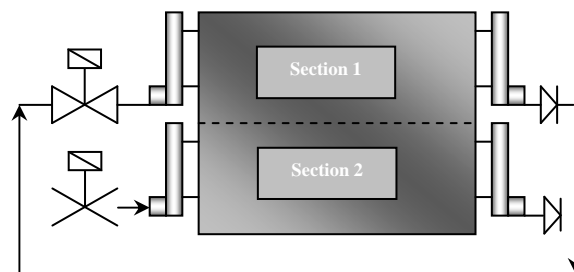

The both coil sections in fact are normally operating in only mechanical cooling working, but when Free Cooling phase is activated, so that outdoor air  $T_2$  are lower than  $(T_1 - \Delta T)^\circ\text{C}$ , in case of a contemporary mechanical cooling request (integration), the section 1 is excluded and the ventilation can be forced at most maintaining an excellent control of the condensing pressure.

In total free cooling field, the cooling capacity is modulated regulating the fans speed to keep the outlet water T constant.

To prevent that the 3-way valve blocks off, it is automatically exchanged up to 30% in every 140 h of work maintaining the cooler in motion.

## 9 CONTROL DEVICE SETTINGS

### 9.1 GENERALITIES

All the control devices are set and tested in the factory before the unit is dispatched. However, after the unit has been in service for a reasonable period of time you can perform a check on the operating and safety devices. The settings are shown in Tables II and III.



**The control devices may be serviced SOLELY BY QUALIFIED TECHNICIANS: incorrect settings may cause serious damage to the unit and injury to persons.**

Many of the operating parameters and system settings are configured by means of the microprocessor control and are protected by passwords.

**TABLE II – SETTING OF CONTROL DEVICES**

- HWA SERIES

CONTROL DEVICE		SET POINT	DIFFERENTIAL
Service Thermostat [CS-CL]	°C	12	4
Service Thermostat [HS-HL]	°C	40	4

- HWA-F SERIES

CONTROL DEVICE		SET POINT	DIFFERENTIAL
Service Thermostat [FS-FL]	°C	10-18	1-3

TABLE III – SETTING OF SAFETY-CONTROL DEVICES

## - HWA SERIES

CONTROL DEVICE		ACTIVATION	DIFFERENTIAL	RESETTING
Antifreeze thermostat	°C	+4	2	Automatic
Safety maximum pressure switch	bars	28	4	Manual
High pressure relief valve	bars	29	-	-
Minimum pressure switch	bars	2	1.5	Automatic
Modulating condensation control device	bars	14	7	
Time lapse between two starts of the same compressor	s	480	-	-
Delay in flow switch alarm	s	20	-	-
Delay in low pressure alarm	s	120	-	-
Pump rotation [optional]	h	24		
End-of-defrost pressure	bars	19	-	-
Maximum defrost time	s	360	-	-
Minimum time lapse between two defrosting operations	s	1800	-	-

## - HWA FREE-COOLING SERIES

CONTROL DEVICE		ACTIVATION	DIFFERENTIAL	RESETTING
Antifreeze thermostat	°C	+4	2	Automatic
Safety maximum pressure switch	bars	28	4	Manual
High pressure relief valve	bars	29	-	-
Minimum pressure switch	bars	2	1.5	Automatic
Modulating condensation control device	bars	14	7	
Time lapse between two starts of the same compressor	s	480	-	-
Delay in flow switch alarm	s	20	-	-
Delay in low pressure alarm	s	120	-	-
Pump rotation [optional]	h	24		
End-of-defrost pressure	bars	n.a.	-	-
Maximum defrost time	s	n.a.	-	-
Minimum time lapse between two defrosting operations	s	n.a.	-	-
Safety valve water side	bars	3		
Max PN water side with tank	bars	3		
Max PN standard 3-way valve	bars	6		
Max PN 3-way valve stem (option)	bars	16		

## 9.2 MAXIMUM PRESSURE SWITCH

The high pressure switch is of the manually reset type and classifiable as category IV under EEC 97/23. It directly stops the compressor when the discharge pressure exceeds the set value.



Warning: do not attempt to change the setting of the pressure switch: should the latter fail to trip in the event of a pressure increase, the pressure relief valve will open!

To verify its efficiency, while the compressors are running, close off the passage of air into the condensers and check by referring to the compressor outlet pressure gauge (previously installed) whether the pressure switch trips (i.e. the compressors stop) when the set value is reached.



Warning: while you are carrying out this check, you should be ready to shut off the unit as directed in the section "Stopping the Unit" in case the safety device fails to trip

The high pressure switch must be **manually reset**; this is possible only when the pressure falls below the set differential (see Table III).

## 9.3 MINIMUM PRESSURE SWITCH

The low pressure switch stops the compressor when the intake pressure falls below the set value for more than 180 seconds.

The switch is automatically reset when the pressure rises above the set differential (see Table III); however, the unit will not resume operation until the alarm memory on the microprocessor control is cleared.

## 9.4 SERVICE THERMOSTAT

The function of this device is to start and stop the compressors according to the demand for chilled water, as determined by a sensor placed at the evaporator inlet [water returning from the circuit] This device is a function included in the microprocessor control and works with a proportional bandwidth that may be set as desired.

## 9.5 ANTIFREEZE THERMOSTAT

The antifreeze sensor situated at the evaporator outlet detects the presence of excessively low temperatures and stops the unit. Together with the flow switch and low pressure switch, this device protects the evaporator from the risk of freezing as a result of faults in the water circuit. This device is a function included in the microprocessor control.

## 9.6 ANTI-RECYCLE TIMER

The function of the timer is to prevent excessively frequent compressor starts and stops. This device is a function included in the microprocessor control. It imposes a minimum time lapse of 300 seconds between two successive starts.



Never attempt to change the delay set in the factory: wrong settings could cause serious damage to the unit.

## 9.7 OIL DIFFERENTIAL PRESSURE SWITCH

HWA units are equipped with spinning scroll compressors; these compressors do not have a lubricant pump and therefore no oil differential pressure switch is provided.

# 10 ROUTINE MAINTENANCE AND CHECKS

## 10.1 WARNINGS



**All the operations described in this chapter MUST ALWAYS BE PERFORMED BY QUALIFIED PERSONNEL.**



**Before carrying out any work on the unit or accessing internal parts, make sure you have disconnected it from the mains electricity supply.**



**The upper part and outlet pipe of the compressor may reach temperatures as high as 110°C. Be especially careful when working in the surrounding area while the unit is running.**



**Be especially careful when working in proximity to finned coils since the 0.11 mm-thick aluminium fins can cause superficial injuries due to cuts.**



**After completing maintenance jobs, always replace the panels enclosing the units and secure them with the fastening screws provided.**



## 10.2 GENERALITIES

It is a good idea to carry out periodic checks to ensure that the unit is working properly:

- Check the efficiency of all the control and safety devices as previously described.
- Check the terminals on the electric control board and compressor terminal boards to ensure that they are securely tightened. The movable and fixed contacts of the circuit breakers must be periodically cleaned and replaced whenever they show signs of deterioration.
- Check the refrigerant level by means of the liquid level indicator (every 6 months).
- Check the oil levels through the windows provided on the compressor crankcases (every 6 months).
- Check the water circuit for leaks (every 6 months).
- If the unit has to remain out of service for a long time, drain the water from the pipes and heat exchanger, from the pump/s (option), from the collect tank (option), and from the water coil if they are FREE COOLING units (if you don't use glycolated solutions). This is indispensable if during the period of quiescence the ambient temperature is expected to fall below the freezing point of the fluid used (routine seasonal operation).
- Check the replenishment of the hydraulic circuit allowing air in the circuit to escape from the small valves put on the highest points.
- Check the efficiency of the flow switch or differential pressure switch
- Check the heating elements, where present, of the compressor crankcases.
- Clean the metal mesh filters mounted externally on the water pipes.
- Check the humidity indicator on the liquid level indicator (green=dry, yellow=humid); if the indicator is not green as shown on the indicator sticker, replace the filter (every 6 months).
- Check that the noise emissions of the unit are regular (every 6 months) and more specifically that no vibrations and/or knocking can be detected.

## 10.3 REPAIRING THE COOLING CIRCUIT



**Warning: while performing repairs on the cooling circuit or maintenance work on the compressors, make sure the circuit is left open for as little time as possible. Even if briefly exposed to air, ester oils tend to absorb large amounts of humidity, which results in the formation of weak acids.**

If the cooling circuit has undergone any repairs, the following operations must be carried out:

- tightness test;
- emptying and drying of the cooling circuit;
- charging with refrigerant.



If the system has to be drained, always recover the refrigerant present in the circuit using suitable equipment; the refrigerant should be handled exclusively in the liquid phase.

## 10.4 TIGHTNESS TEST

Fill the circuit with anhydrous nitrogen supplied from a tank with a pressure-reducing valve until the pressure rises to 10 bars.



During the pressurisation phase, do not exceed the pressure setting of the safety valves; otherwise you will cause the latter to open.

The presence of any leaks must be determined using special leak detectors. Should any leaks be detected during the test, empty out the circuit before repairing the leaks with suitable alloys.



Do not use oxygen in the place of nitrogen as a test agent, since this could cause a risk of explosion as well as the certainty of extensive oxidation in high-temperature areas.

## 10.5 HARD VACUUM AND DRYING OF THE COOLING CIRCUIT

To achieve a hard vacuum in the cooling circuit it is necessary to use a pump capable of generating a high degree of vacuum, i.e. 15 Pa of absolute pressure.

If there is no suitable vacuum pump available, or whenever the circuit has remained open for long periods of time, you are strongly recommended to adopt the triple evacuation method. This method is also recommended when there is a presence of humidity within the circuit.

The vacuum pump should be connected to the inlets.

The procedure to be carried out is as follows:

- Evacuate the circuit until you reach an absolute pressure of at least 35 Pa: at this point inject nitrogen into the circuit until you reach a relative pressure of about 1 bar.
- Repeat the step described above.
- Carry out the step described above for the third time, but in this case attempting to reach the hardest vacuum possible.

Using this procedure you can easily remove up to 99% of pollutants.

## 10.6 CHARGING WITH R407C REFRIGERANT

- Connect the cylinder of refrigerant gas to the male 1/4 SAE inlet situated on the liquid line after discharging a little gas to eliminate air in the connection pipe.
- **Carry out the charging operation with the refrigerant in liquid form** until you reach 75% of the total charge.
- Then connect to the inlet on the intake line and complete the charging process with the refrigerant **in liquid form** until no more bubbles can be seen on the liquid level indicator and the operating parameters specified in the section "Checking the refrigerant level" have been reached".



Since R407C is a ternary mixture, charging must take place exclusively with liquid refrigerant to ensure the correct percentages of the three constituents. Introduce refrigerant through the inlet in the liquid line.



A unit that was originally charged with R407C in the factory cannot be charged with R22 or other refrigerants.

## 10.7 ENVIRONMENTAL PROTECTION

The law implementing the regulations [reg. EEC 2037/00] which govern the use of ozone-depleting substances and greenhouse gases bans the dispersal of refrigerant gases in the environment and requires whoever is in their possession to recover them and, at the end of their useful life, either to return them to the dealer or take them to a suitable waste disposal facility.

The refrigerant HFC R407C is not harmful to the ozone layer but is included among the substances responsible for the greenhouse effect and thus falls within the scope of the aforesaid regulations.



Therefore, special care should be taken when carrying out maintenance work to minimise refrigerant leaks.

## 11 RETIRING THE UNIT

When the unit has reached the end of its working life and needs to be removed and replaced, a series of operations should be carried out:

- the refrigerant gas it contains should be recovered by specialised personnel and sent to a waste collection facility;
- the lubricating oil in the compressors should also be recovered and sent to a waste collection facility;
- if they cannot be reused, the framework and components should be scrapped and separated according to the type of material: this applies especially for the considerable quantities of copper and aluminium present in the unit.

This will make the job of waste collection, disposal and recycling facilities easier and minimise the environmental impact of such processes.

## 12 TROUBLESHOOTING

On the next pages you will find a list of the most common causes that may cause the chilling unit to fail or malfunction. These causes are broken down according to easily identifiable symptoms.



You should be extremely careful when attempting to implement any of the possible remedies suggested: overconfidence can result in injuries, even serious ones, to inexperienced individuals. Therefore, once the cause has been identified, you are advised to contact the manufacturer or a qualified technician for help.

FAULT	Possible causes	Corrective actions
<b>The unit does not start</b>	No power supply	Check that power is being supplied both to the primary and auxiliary circuits.
	The electronic card is cut off from the power supply	Check the fuses
	Alarms have been triggered	Check whether any alarms are signalled on the microprocessor control panel, eliminate the causes and restart the unit.
	The phase sequence is wrong	Invert two phases in the primary power line after disconnecting them upstream from the unit
<b>The compressor is noisy</b>	The compressor is rotating in the wrong direction	Check the phase sequence relay. Invert the phases on the terminal board after disconnecting the unit and contact the manufacturer.
<b>Presence of abnormally high pressure</b>	Insufficient flow of air to the condenser	Check whether all the fans are turning properly
		Check the air T at the condenser inlet and make sure no back suction occurs
		Check whether the effective RMS voltage to the fans is the maximum. If necessary, check the pressure transducers controlling the revolution regulator, where present [optional]
		Check the cleanliness of the finned coils
	Presence of air in the refrigerant circuit, as revealed by the presence of bubbles in the flow indicator also with undercooling values exceeding 5 °C	Drain and pressurise the circuit and check for leaks. Generate a slow vacuum [longer than 3 hours] until reaching a pressure of 15 Pa and then recharge in the liquid phase
	Unit overcharged, as revealed by an undercooling of more than 8 °C	Drain the circuit
	Thermostatic valve and/or filter obstructed. These symptoms may also occur in the presence of an abnormally low pressure.	Check the temperatures upstream and downstream from the valve and filter and replace them if necessary.
Insufficient flow of water in the case of heat pump operation	Check the water circuit for pressure drops and/or whether the pump is working properly [direction of rotation]. Check the outgoing water T and make sure it less than or equal to 45°C	

FAULT	Possible causes	Corrective actions
<b>Low condensation pressure</b>	Transducer fault	Check the transducers and the efficiency of the needle pusher on the schrader valves they are connected to
	Outdoor T too low and/or presence of strong winds	Install the condensation control device and/or protect the unit from prevalent winds
	Low water T, in the case of heat pump operation	Check whether the thermal load is compatible with the unit's potential.
<b>Low evaporation pressure</b>	Insufficient flow of water	Check whether the pumps are rotating in the right direction. Check the water system for pressure drops. Check the efficiency of the pump system check valve (optional)
	Malfunctioning of thermostatic valve	Warming the bulb with your hand, check whether the valve opens and adjust it if necessary. If it does not respond, replace it.
	Filter clogged	Pressure drops upstream and downstream from the filter should not exceed 2°C. If they do, replace the filter.
	Low condensation T	Check the efficiency of the condensation control device [where present]
	Low level of refrigerant	Check the refrigerant level by measuring the degree of undercooling; if it is below 2°C replenish the charge
	Coil covered with frost, in the case of heat pump operation	Check whether the defrost parameters have been properly set. Check the efficiency of the 4-way valve.
	Low outdoor T, if the unit is operating with the heat pump on	Check compliance with the operating limits and eliminate any bypasses and back flow of air.
<b>The compressor does not start</b>	The internal thermal protection device has tripped	In the case of compressors equipped with a protection module, check the thermal contact. Identify the causes after restarting.
	The circuit breakers or line fuses have been tripped by a short circuit	Pinpoint the cause by measuring the resistance of the individual windings and the insulation from the casing before restoring power.
	One of the high or low pressure switches has tripped	Check on the microprocessor, eliminate the causes.
	The phases have been inverted in the distribution compartment	Check the phase sequence relay.

FAULT	Possible causes	Corrective actions
<b>High evaporation pressure</b>	Water T too high	Check the thermal load and/or efficiency of the thermostat function.
		Check the efficiency of the thermostatic valve
<b>Defrosting absent or incomplete (HS-HL versions)</b>	Error in parameter settings	Check the setting of the start and end defrost parameters on the microprocessor
		Check whether defrosting water is properly drained from the coils
		Check the uniformity of the refrigerant circuit outlet temperatures at the top and bottom of the coils: the maximum thermal differential allowed is 10 °C. Check the refrigerant level
	The 4-way valve has failed to work	Check whether it is regularly energized and deenergized.
<b>Free Cooling malfunctioning (FS-FL units)</b>	Failure to exchange the 3-way valve in activation	It is possible to hand-force the valve to open, but it is <u>advisable</u> to leave the unit working only mechanically
	Failure to exchange the 3-way valve in deactivation	It is necessary to hand-force the valve to close, replacing its servomotor as soon as possible.

### 13 WATER PRESSURE DROPS

#### 13.1 EVAPORATOR PRESSURE DROPS

The diagram shows the pressure drops on the water side ( $D_{pw}$ ) as a function of the water flow rate ( $Q_w$ ), assuming an average water temperature of 10°C

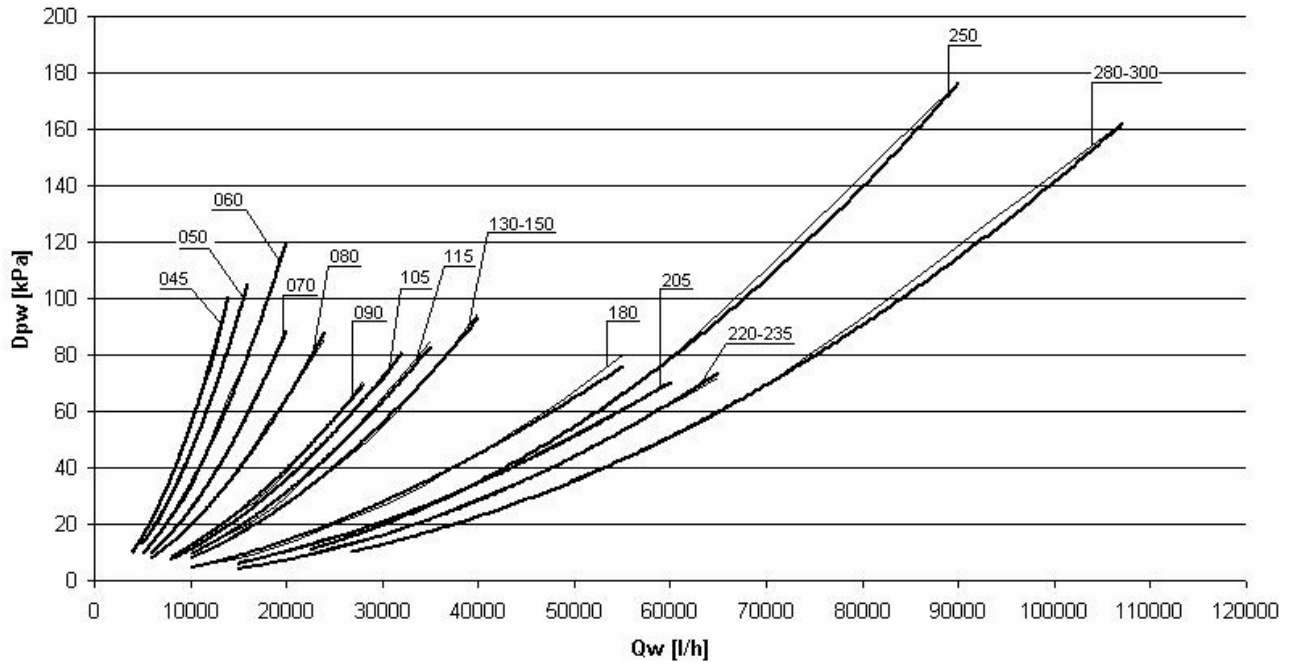

#### 13.2 RECUPERATOR PRESSURE DROPS

The diagram shows the pressure drops on the water side ( $D_{pw}$ ) as a function of the water flow rate ( $Q_w$ ), assuming an average water temperature of 42.5°C

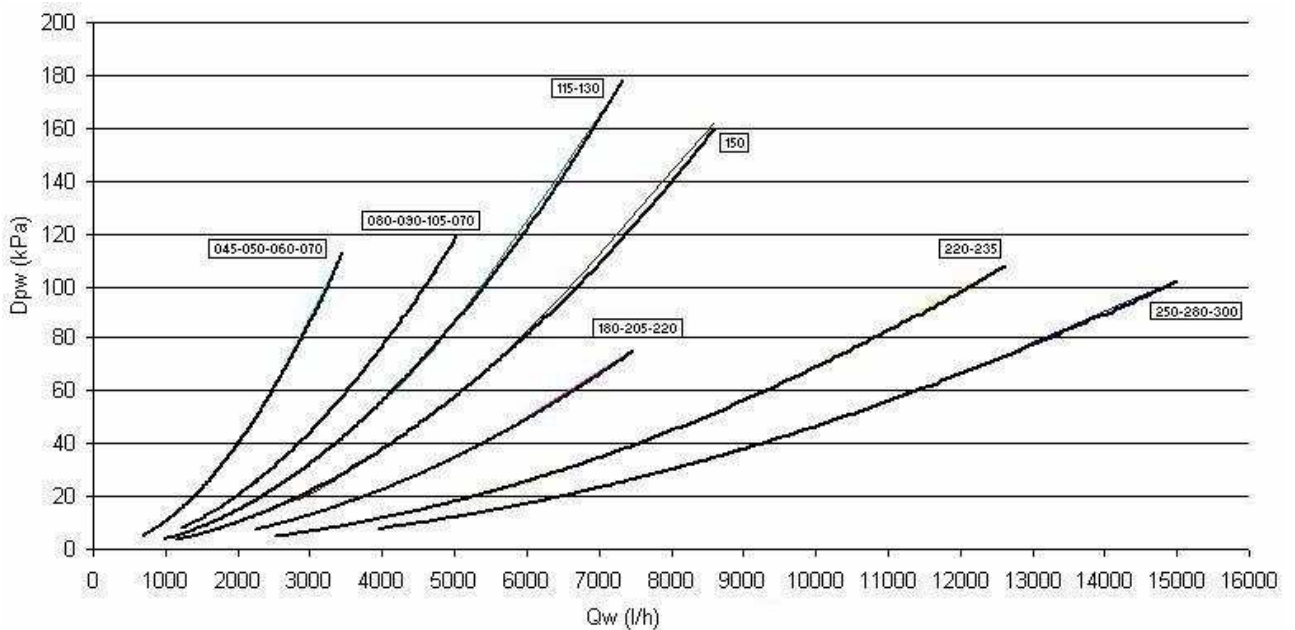



### 13.3 FREE COOLING COILS PRESSURE DROPS

The diagram shows the pressure drops of the free cooling coils dependent on water flow, referred to the water average temperature 12 °C (outlet from the coils).

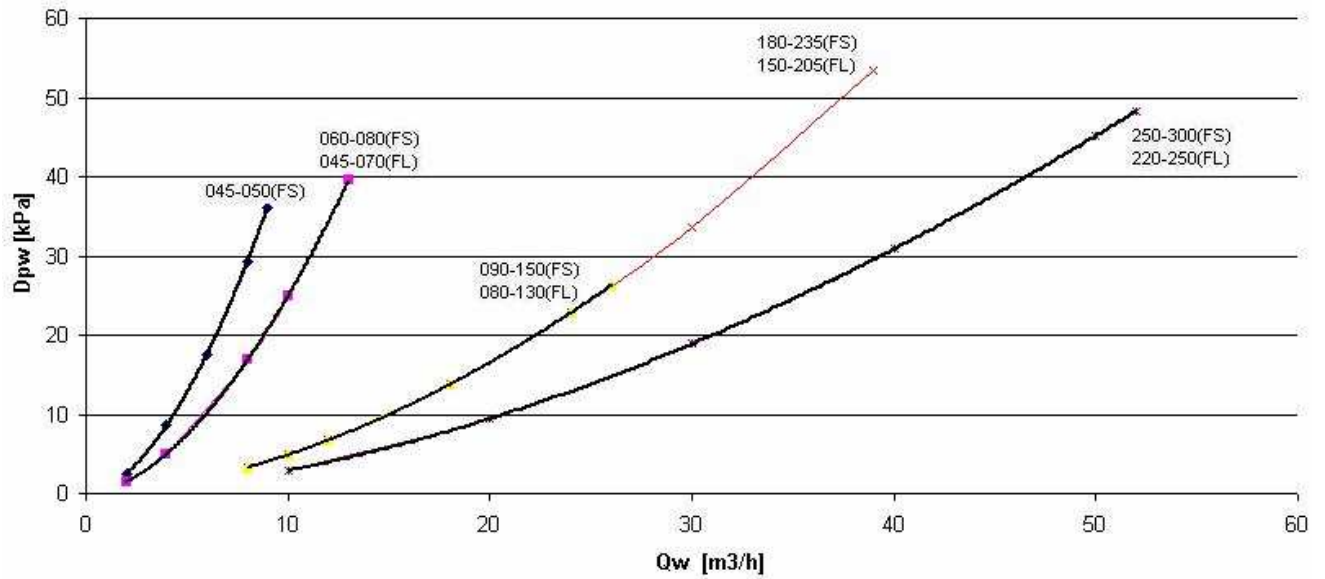

### 13.4 WEIGHTS SUMMARIZING TABLES

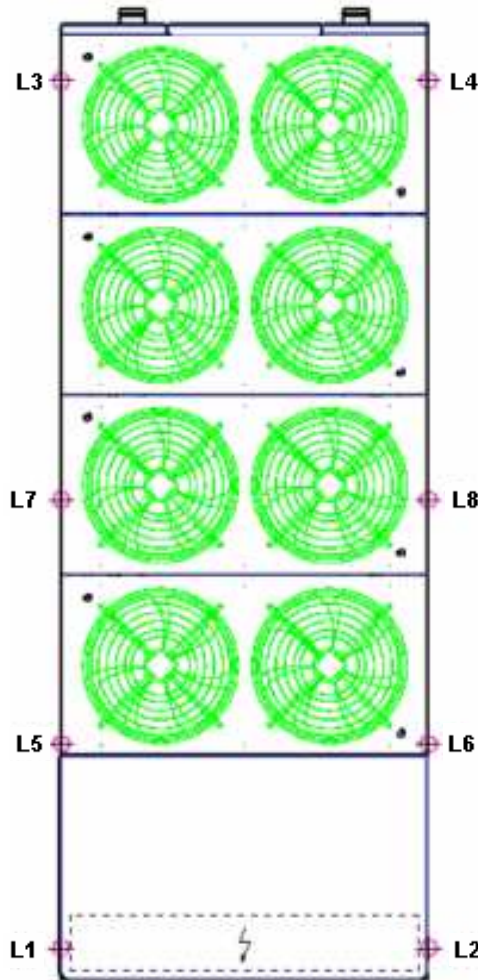

In this draw you can see the points of the unit we have calculated the weight values for, and they are shown in the following tables: nota bene, the hydronic modules weight values (C-H, F; with 2 pumps+full tank, with 2 pumps, with 1 pump) must be added to the weight values of the standard units, basic version (C-H-F; only cooling STD, heat pump STD, free cooling STD).

FRAME	LENGHT	DEPTH	HEIGHT
1	1960	1197	1578.5
2	2360	1197	1578.5
3	3140	1197	1578.5
4	3481.5	1654	1637
5	4296	1654	1637
6	4296	1654	2137



13.4.1 TOTAL WEIGHTS STD C-H-F

➤ Only cooling HWA weights

MODEL	045	050	060	070	080	090	105	115CS	115CL
FRAME	1	1	2	2	2	3	3	4	4
Total [kg]	581,15	591,99	688,92	704,09	725,78	928,36	985,36	1233,68	1264,68
L1	174,345	177,597	120,561	123,21575	127,0115	162,463	172,438	185,052	189,702
L2	174,345	177,597	120,561	123,21575	127,0115	162,463	172,438	185,052	189,702
L3	116,23	118,398	103,338	105,6135	108,867	139,254	147,804	123,368	126,468
L4	116,23	118,398	103,338	105,6135	108,867	139,254	147,804	123,368	126,468
L5			120,561	123,21575	127,0115	162,463	172,438	185,052	189,702
L6			120,561	123,21575	127,0115	162,463	172,438	185,052	189,702
L7								123,368	126,468
L8								123,368	126,468
MODEL	130CS	130CL	150CS	150CL	180CS	180CL	205CS	205CL	220CS
FRAME	4	4	4	4	4	5	5	5	5
Total [kg]	1241,68	1272,68	1426,37	1472,37	1585,31	1830,54	1885,54	1885,54	1921,04
L1	186,252	190,902	213,9555	220,8555	237,7965	274,581	282,831	282,831	288,156
L2	186,252	190,902	213,9555	220,8555	237,7965	274,581	282,831	282,831	288,156
L3	124,168	127,268	142,637	147,237	158,531	183,054	188,554	188,554	192,104
L4	124,168	127,268	142,637	147,237	158,531	183,054	188,554	188,554	192,104
L5	186,252	190,902	213,9555	220,8555	237,7965	274,581	282,831	282,831	288,156
L6	186,252	190,902	213,9555	220,8555	237,7965	274,581	282,831	282,831	288,156
L7	124,168	127,268	142,637	147,237	158,531	183,054	188,554	188,554	192,104
L8	124,168	127,268	142,637	147,237	158,531	183,054	188,554	188,554	192,104
MODEL	220CL	235CS	235CL	250CS	250CL	280CS	280CL	300CS	300CL
FRAME	5	5	5	6	6	6	6	6	6
Total [kg]	1987,04	1931,04	1998,04	2198,34	2244,76	2237,14	2283,56	2289,34	2305,76
L1	298,056	289,656	299,706	329,751	336,714	335,571	342,534	343,401	345,864
L2	298,056	289,656	299,706	329,751	336,714	335,571	342,534	343,401	345,864
L3	198,704	193,104	199,804	219,834	224,476	223,714	228,356	228,934	230,576
L4	198,704	193,104	199,804	219,834	224,476	223,714	228,356	228,934	230,576
L5	298,056	289,656	299,706	329,751	336,714	335,571	342,534	343,401	345,864
L6	298,056	289,656	299,706	329,751	336,714	335,571	342,534	343,401	345,864
L7	198,704	193,104	199,804	219,834	224,476	223,714	228,356	228,934	230,576
L8	198,704	193,104	199,804	219,834	224,476	223,714	228,356	228,934	230,576

➤ Heat pump HWA weights

MODEL	045	050	060	070	080	090	105	115HS	115HL
FRAME	1	1	2	2	2	3	3	4	4
Total [kg]	601,15	611,99	710,92	726,09	747,78	953,36	1010,36	1263,68	1294,68
L1	180,345	183,597	124,411	127,06575	130,8615	166,838	176,813	189,552	194,202
L2	180,345	183,597	124,411	127,06575	130,8615	166,838	176,813	189,552	194,202
L3	120,23	122,398	106,638	108,9135	112,167	143,004	151,554	126,368	129,468
L4	120,23	122,398	106,638	108,9135	112,167	143,004	151,554	126,368	129,468
L5			124,411	127,06575	130,8615	166,838	176,813	189,552	194,202
L6			124,411	127,06575	130,8615	166,838	176,813	189,552	194,202
L7								126,368	129,468
L8								126,368	129,468
MODEL	130HS	130HL	150HS	150HL	180HS	180HL	205HS	205HL	220HS
FRAME	4	4	4	4	4	5	5	5	5
Total [kg]	1271,68	1302,68	1456,37	1502,37	1615,31	1865,54	1920,54	1920,54	1956,04
L1	190,752	195,402	218,4555	225,3555	242,2965	279,831	288,081	288,081	293,406
L2	190,752	195,402	218,4555	225,3555	242,2965	279,831	288,081	288,081	293,406
L3	127,168	130,268	145,637	150,237	161,531	186,554	192,054	192,054	195,604
L4	127,168	130,268	145,637	150,237	161,531	186,554	192,054	192,054	195,604
L5	190,752	195,402	218,4555	225,3555	242,2965	279,831	288,081	288,081	293,406
L6	190,752	195,402	218,4555	225,3555	242,2965	279,831	288,081	288,081	293,406
L7	127,168	130,268	145,637	150,237	161,531	186,554	192,054	192,054	195,604
L8	127,168	130,268	145,637	150,237	161,531	186,554	192,054	192,054	195,604
MODEL	220HL	235HS	235HL	250HS	250HL	280HS	280HL	300HS	300HL
FRAME	5	5	5	6	6	6	6	6	6
Total [kg]	2024,04	1966,04	2034,04	2261,86	2308,28	2330,66	2347,08	2352,86	2369,28
L1	303,606	294,906	305,106	339,279	346,242	349,599	352,062	352,929	355,392
L2	303,606	294,906	305,106	339,279	346,242	349,599	352,062	352,929	355,392
L3	202,404	196,604	203,404	226,186	230,828	233,066	234,708	235,286	236,928
L4	202,404	196,604	203,404	226,186	230,828	233,066	234,708	235,286	236,928
L5	303,606	294,906	305,106	339,279	346,242	349,599	352,062	352,929	355,392
L6	303,606	294,906	305,106	339,279	346,242	349,599	352,062	352,929	355,392
L7	202,404	196,604	203,404	226,186	230,828	233,066	234,708	235,286	236,928
L8	202,404	196,604	203,404	226,186	230,828	233,066	234,708	235,286	236,928

➤ Free cooling HWA weights

MODEL	045FS	045FL	050FS	050FL	060FS	060FL	070FS	070FL
FRAME	1	2	1	2	2	2	2	2
<b>Total [kg]</b>	<b>707,35</b>	<b>808,18</b>	<b>718,19</b>	<b>819,02</b>	<b>837,52</b>	<b>858,52</b>	<b>852,69</b>	<b>873,69</b>
L1	212,205	141,4315	215,457	143,3285	146,566	150,241	149,22075	152,89575
L2	212,205	141,4315	215,457	143,3285	146,566	150,241	149,22075	152,89575
L3	141,47	121,227	143,638	122,853	125,628	128,778	127,9035	131,0535
L4	141,47	121,227	143,638	122,853	125,628	128,778	127,9035	131,0535
L5		141,4315		143,3285	146,566	150,241	149,22075	152,89575
L6		141,4315		143,3285	146,566	150,241	149,22075	152,89575
L7								
L8								
MODEL	080FS	080FL	090FS	090FL	105FS	0105FL	115FS	115FL
FRAME	2	3	3	4	3	4	4	4
<b>Total [kg]</b>	<b>874,38</b>	<b>1056,76</b>	<b>1131,76</b>	<b>1460,28</b>	<b>1188,76</b>	<b>1471,68</b>	<b>1452,08</b>	<b>1483,08</b>
L1	153,0165	184,933	198,058	219,042	208,033	220,752	217,812	222,462
L2	153,0165	184,933	198,058	219,042	208,033	220,752	217,812	222,462
L3	131,157	158,514	169,764	146,028	178,314	147,168	145,208	148,308
L4	131,157	158,514	169,764	146,028	178,314	147,168	145,208	148,308
L5	153,0165	184,933	198,058	219,042	208,033	220,752	217,812	222,462
L6	153,0165	184,933	198,058	219,042	208,033	220,752	217,812	222,462
L7				146,028		147,168	145,208	148,308
L8				146,028		147,168	145,208	148,308
MODEL	130FS	130FL	150FS	150FL	180FS	180FL	205FS	205FL
FRAME	4	4	4	5	5	5	5	5
<b>Total [kg]</b>	<b>1460,08</b>	<b>1491,08</b>	<b>1644,77</b>	<b>1939,9</b>	<b>2052,84</b>	<b>2100,84</b>	<b>2155,84</b>	<b>2209,84</b>
L1	219,012	223,662	246,7155	290,985	307,926	315,126	323,376	331,476
L2	219,012	223,662	246,7155	290,985	307,926	315,126	323,376	331,476
L3	146,008	149,108	164,477	193,99	205,284	210,084	215,584	220,984
L4	146,008	149,108	164,477	193,99	205,284	210,084	215,584	220,984
L5	219,012	223,662	246,7155	290,985	307,926	315,126	323,376	331,476
L6	219,012	223,662	246,7155	290,985	307,926	315,126	323,376	331,476
L7	146,008	149,108	164,477	193,99	205,284	210,084	215,584	220,984
L8	146,008	149,108	164,477	193,99	205,284	210,084	215,584	220,984
MODEL	220FS	220FL	235FS	235FL	250FS	250FL	280FS	300FS
FRAME	5	6	5	6	6	6	6	6
<b>Total [kg]</b>	<b>2191,34</b>	<b>2560,76</b>	<b>2201,34</b>	<b>2572,16</b>	<b>2537,14</b>	<b>2583,56</b>	<b>2575,94</b>	<b>2628,14</b>
L1	328,701	384,114	330,201	385,824	380,571	387,534	386,391	394,221
L2	328,701	384,114	330,201	385,824	380,571	387,534	386,391	394,221
L3	219,134	256,076	220,134	257,216	253,714	258,356	257,594	262,814
L4	219,134	256,076	220,134	257,216	253,714	258,356	257,594	262,814
L5	328,701	384,114	330,201	385,824	380,571	387,534	386,391	394,221
L6	328,701	384,114	330,201	385,824	380,571	387,534	386,391	394,221
L7	219,134	256,076	220,134	257,216	253,714	258,356	257,594	262,814
L8	219,134	256,076	220,134	257,216	253,714	258,356	257,594	262,814

13.4.2 HYDRONIC MODULES WEIGHTS C-H

➤ **Weights with 2 pumps + full tank (to be added to STD weight)**

MODEL	045	050	060	070	080	090	105	115CS-HS	115CL-HL
FRAME	1	1	2	2	2	3	3	4	4
<b>Total [kg]</b>	<b>415,59</b>	<b>415,59</b>	<b>571,42</b>	<b>571,42</b>	<b>571,42</b>	<b>692,2</b>	<b>692,2</b>	<b>895,6</b>	<b>895,6</b>
L1	83,118	83,118	57,142	57,142	57,142	69,22	69,22	17,912	17,912
L2	83,118	83,118	57,142	57,142	57,142	69,22	69,22	17,912	17,912
L3	124,677	124,677	114,284	114,284	114,284	138,44	138,44	179,12	179,12
L4	124,677	124,677	114,284	114,284	114,284	138,44	138,44	179,12	179,12
L5			114,284	114,284	114,284	138,44	138,44	71,648	71,648
L6			114,284	114,284	114,284	138,44	138,44	71,648	71,648
L7								179,12	179,12
L8								179,12	179,12
MODEL	130CS-HS	130CL-HL	150CS-HS	150CL-HL	180CS-HS	180CL-HL	205CS-HS	205CL-HL	220CS-HS
FRAME	4	4	4	4	4	5	5	5	5
<b>Total [kg]</b>	<b>895,6</b>	<b>895,6</b>	<b>896,6</b>	<b>896,6</b>	<b>934,6</b>	<b>1151,465</b>	<b>1151,465</b>	<b>1151,465</b>	<b>1151,465</b>
L1	17,912	17,912	17,932	17,932	18,692	23,0293	23,0293	23,0293	23,0293
L2	17,912	17,912	17,932	17,932	18,692	23,0293	23,0293	23,0293	23,0293
L3	179,12	179,12	179,32	179,32	186,92	230,293	230,293	230,293	230,293
L4	179,12	179,12	179,32	179,32	186,92	230,293	230,293	230,293	230,293
L5	71,648	71,648	71,728	71,728	74,768	92,1172	92,1172	92,1172	92,1172
L6	71,648	71,648	71,728	71,728	74,768	92,1172	92,1172	92,1172	92,1172
L7	179,12	179,12	179,32	179,32	186,92	230,293	230,293	230,293	230,293
L8	179,12	179,12	179,32	179,32	186,92	230,293	230,293	230,293	230,293
MODEL	220CL-HL	235CS-HS	235CL-HL	250CS-HS	250CL-HL	280CS-HS	280CL-HL	300CS-HS	300CL-HL
FRAME	5	5	5	6	6	6	6	6	6
<b>Total [kg]</b>	<b>1151,465</b>	<b>1151,465</b>	<b>1151,465</b>	<b>1160,43</b>	<b>1161,43</b>	<b>1162,43</b>	<b>1163,43</b>	<b>1164,43</b>	<b>1165,43</b>
L1	23,0293	23,0293	23,0293	23,2086	23,2286	23,2486	23,2686	23,2886	23,3086
L2	23,0293	23,0293	23,0293	23,2086	23,2286	23,2486	23,2686	23,2886	23,3086
L3	230,293	230,293	230,293	301,7118	301,9718	302,2318	302,4918	302,7518	303,0118
L4	230,293	230,293	230,293	301,7118	301,9718	302,2318	302,4918	302,7518	303,0118
L5	92,1172	92,1172	92,1172	23,2086	23,2286	23,2486	23,2686	23,2886	23,3086
L6	92,1172	92,1172	92,1172	23,2086	23,2286	23,2486	23,2686	23,2886	23,3086
L7	230,293	230,293	230,293	232,086	232,286	232,486	232,686	232,886	233,086
L8	230,293	230,293	230,293	232,086	232,286	232,486	232,686	232,886	233,086

➤ **Weights with 2 pumps (to be added to STD weight)**

MODEL	045	050	060	070	080	090	105	115CS-HS	115CL-HL
FRAME	1	1	2	2	2	3	3	4	4
<b>Total [kg]</b>	<b>160,59</b>	<b>160,59</b>	<b>191,42</b>	<b>191,42</b>	<b>191,42</b>	<b>195,2</b>	<b>195,2</b>	<b>196,6</b>	<b>196,6</b>
L1	16,059	16,059	19,142	19,142	19,142	19,52	19,52	3,932	3,932
L2	16,059	16,059	19,142	19,142	19,142	19,52	19,52	3,932	3,932
L3	64,236	64,236	19,142	19,142	19,142	19,52	19,52	51,116	51,116
L4	64,236	64,236	19,142	19,142	19,142	19,52	19,52	51,116	51,116
L5			57,426	57,426	57,426	58,56	58,56	3,932	3,932
L6			57,426	57,426	57,426	58,56	58,56	3,932	3,932
L7								39,32	39,32
L8								39,32	39,32
MODEL	130CS-HS	130CL-HL	150CS-HS	150CL-HL	180CS-HS	180CL-HL	205CS-HS	205CL-HL	220CS-HS
FRAME	4	4	4	4	4	5	5	5	5
<b>Total [kg]</b>	<b>196,6</b>	<b>196,6</b>	<b>197,6</b>	<b>197,6</b>	<b>235,6</b>	<b>254,465</b>	<b>254,465</b>	<b>254,465</b>	<b>254,465</b>
L1	3,932	3,932	3,952	3,952	4,712	5,0893	5,0893	5,0893	5,0893
L2	3,932	3,932	3,952	3,952	4,712	5,0893	5,0893	5,0893	5,0893
L3	51,116	51,116	51,376	51,376	61,256	66,1609	66,1609	66,1609	66,1609
L4	51,116	51,116	51,376	51,376	61,256	66,1609	66,1609	66,1609	66,1609
L5	3,932	3,932	3,952	3,952	4,712	5,0893	5,0893	5,0893	5,0893
L6	3,932	3,932	3,952	3,952	4,712	5,0893	5,0893	5,0893	5,0893
L7	39,32	39,32	39,52	39,52	47,12	50,893	50,893	50,893	50,893
L8	39,32	39,32	39,52	39,52	47,12	50,893	50,893	50,893	50,893
MODEL	220CL-HL	235CS-HS	235CL-HL	250CS-HS	250CL-HL	280CS-HS	280CL-HL	300CS-HS	300CL-HL
FRAME	5	5	5	6	6	6	6	6	6
<b>Total [kg]</b>	<b>254,465</b>	<b>254,465</b>	<b>254,465</b>	<b>263,23</b>	<b>264,23</b>	<b>265,23</b>	<b>266,23</b>	<b>267,23</b>	<b>268,23</b>
L1	5,0893	5,0893	5,0893	5,2646	5,2846	5,3046	5,3246	5,3446	5,3646
L2	5,0893	5,0893	5,0893	5,2646	5,2846	5,3046	5,3246	5,3446	5,3646
L3	66,1609	66,1609	66,1609	68,4398	68,6998	68,9598	69,2198	69,4798	69,7398
L4	66,1609	66,1609	66,1609	68,4398	68,6998	68,9598	69,2198	69,4798	69,7398
L5	5,0893	5,0893	5,0893	5,2646	5,2846	5,3046	5,3246	5,3446	5,3646
L6	5,0893	5,0893	5,0893	5,2646	5,2846	5,3046	5,3246	5,3446	5,3646
L7	50,893	50,893	50,893	52,646	52,846	53,046	53,246	53,446	53,646
L8	50,893	50,893	50,893	52,646	52,846	53,046	53,246	53,446	53,646

➤ **Weights with 1 pump (to be added to STD weight)**

MODEL	045	050	060	070	080	090	105	115CS-HS	115CL-HL
FRAME	1	1	2	2	2	3	3	4	4
<b>Total [kg]</b>	<b>128,39</b>	<b>128,39</b>	<b>156,42</b>	<b>156,42</b>	<b>156,42</b>	<b>160,2</b>	<b>160,2</b>	<b>161,6</b>	<b>161,6</b>
L1	12,839	12,839	15,642	15,642	15,642	16,02	16,02	3,232	3,232
L2	12,839	12,839	15,642	15,642	15,642	16,02	16,02	3,232	3,232
L3	51,356	51,356	15,642	15,642	15,642	16,02	16,02	42,016	42,016
L4	51,356	51,356	15,642	15,642	15,642	16,02	16,02	42,016	42,016
L5			46,926	46,926	46,926	48,06	48,06	3,232	3,232
L6			46,926	46,926	46,926	48,06	48,06	3,232	3,232
L7								32,32	32,32
L8								32,32	32,32
MODEL	130CS-HS	130CL-HL	150CS-HS	150CL-HL	180CS-HS	180CL-HL	205CS-HS	205CL-HL	220CS-HS
FRAME	4	4	4	4	4	5	5	5	5
<b>Total [kg]</b>	<b>161,6</b>	<b>161,6</b>	<b>162,6</b>	<b>162,6</b>	<b>175,6</b>	<b>176,465</b>	<b>176,465</b>	<b>176,465</b>	<b>176,465</b>
L1	3,232	3,232	3,252	3,252	3,512	3,5293	3,5293	3,5293	3,5293
L2	3,232	3,232	3,252	3,252	3,512	3,5293	3,5293	3,5293	3,5293
L3	42,016	42,016	42,276	42,276	45,656	45,8809	45,8809	45,8809	45,8809
L4	42,016	42,016	42,276	42,276	45,656	45,8809	45,8809	45,8809	45,8809
L5	3,232	3,232	3,252	3,252	3,512	3,5293	3,5293	3,5293	3,5293
L6	3,232	3,232	3,252	3,252	3,512	3,5293	3,5293	3,5293	3,5293
L7	32,32	32,32	32,52	32,52	35,12	35,293	35,293	35,293	35,293
L8	32,32	32,32	32,52	32,52	35,12	35,293	35,293	35,293	35,293
MODEL	220CL-HL	235CS-HS	235CL-HL	250CS-HS	250CL-HL	280CS-HS	280CL-HL	300CS-HS	300CL-HL
FRAME	5	5	5	6	6	6	6	6	6
<b>Total [kg]</b>	<b>176,465</b>	<b>176,465</b>	<b>176,465</b>	<b>183,37</b>	<b>183,37</b>	<b>183,37</b>	<b>183,37</b>	<b>183,37</b>	<b>183,37</b>
L1	3,5293	3,5293	3,5293	3,6674	3,6674	3,6674	3,6674	3,6674	3,6674
L2	3,5293	3,5293	3,5293	3,6674	3,6674	3,6674	3,6674	3,6674	3,6674
L3	45,8809	45,8809	45,8809	47,6762	47,6762	47,6762	47,6762	47,6762	47,6762
L4	45,8809	45,8809	45,8809	47,6762	47,6762	47,6762	47,6762	47,6762	47,6762
L5	3,5293	3,5293	3,5293	3,6674	3,6674	3,6674	3,6674	3,6674	3,6674
L6	3,5293	3,5293	3,5293	3,6674	3,6674	3,6674	3,6674	3,6674	3,6674
L7	35,293	35,293	35,293	36,674	36,674	36,674	36,674	36,674	36,674
L8	35,293	35,293	35,293	36,674	36,674	36,674	36,674	36,674	36,674

13.4.3 HYDRONIC MODULES WEIGHTS F

➤ **Weights with 2 pumps + full tank (to be added to Free Cooling STD weight)**

MODEL	045FS	045FL	050FS	050FL	060FS	060FL	070FS	070FL
FRAME	1	2	1	2	2	2	2	2
<b>Total [kg]</b>	<b>428,7</b>	<b>577,7</b>	<b>428,7</b>	<b>577,7</b>	<b>584,7</b>	<b>584,7</b>	<b>584,7</b>	<b>584,7</b>
L1	128,61	101,0975	128,61	101,0975	102,3225	102,3225	102,3225	102,3225
L2	128,61	101,0975	128,61	101,0975	102,3225	102,3225	102,3225	102,3225
L3	85,74	86,655	85,74	86,655	87,705	87,705	87,705	87,705
L4	85,74	86,655	85,74	86,655	87,705	87,705	87,705	87,705
L5		101,0975		101,0975	102,3225	102,3225	102,3225	102,3225
L6		101,0975		101,0975	102,3225	102,3225	102,3225	102,3225
L7								
L8								
MODEL	080FS	080FL	090FS	090FL	105FS	0105FL	115FS	115FL
FRAME	2	3	3	4	3	4	4	4
<b>Total [kg]</b>	<b>584,7</b>	<b>705,6</b>	<b>710,9</b>	<b>916,8</b>	<b>710,9</b>	<b>916,8</b>	<b>921,2</b>	<b>921,2</b>
L1	102,3225	123,48	124,4075	137,52	124,4075	137,52	138,18	138,18
L2	102,3225	123,48	124,4075	137,52	124,4075	137,52	138,18	138,18
L3	87,705	105,84	106,635	91,68	106,635	91,68	92,12	92,12
L4	87,705	105,84	106,635	91,68	106,635	91,68	92,12	92,12
L5	102,3225	123,48	124,4075	137,52	124,4075	137,52	138,18	138,18
L6	102,3225	123,48	124,4075	137,52	124,4075	137,52	138,18	138,18
L7				91,68		91,68	92,12	92,12
L8				91,68		91,68	92,12	92,12
MODEL	130FS	130FL	150FS	150FL	180FS	180FL	205FS	205FL
FRAME	4	4	4	5	5	5	5	5
<b>Total [kg]</b>	<b>921,2</b>	<b>921,2</b>	<b>921,2</b>	<b>1121,1</b>	<b>1128,3</b>	<b>1128,3</b>	<b>1128,3</b>	<b>1128,3</b>
L1	138,18	138,18	138,18	168,165	169,245	169,245	169,245	169,245
L2	138,18	138,18	138,18	168,165	169,245	169,245	169,245	169,245
L3	92,12	92,12	92,12	112,11	112,83	112,83	112,83	112,83
L4	92,12	92,12	92,12	112,11	112,83	112,83	112,83	112,83
L5	138,18	138,18	138,18	168,165	169,245	169,245	169,245	169,245
L6	138,18	138,18	138,18	168,165	169,245	169,245	169,245	169,245
L7	92,12	92,12	92,12	112,11	112,83	112,83	112,83	112,83
L8	92,12	92,12	92,12	112,11	112,83	112,83	112,83	112,83
MODEL	220FS	220FL	235FS	235FL	250FS	250FL	280FS	300FS
FRAME	5	6	5	6	6	6	6	6
<b>Total [kg]</b>	<b>1128,3</b>	<b>1130,5</b>	<b>1128,3</b>	<b>1130,5</b>	<b>1134,7</b>	<b>1134,7</b>	<b>1134,7</b>	<b>1134,7</b>
L1	169,245	169,575	169,245	169,575	170,205	170,205	170,205	170,205
L2	169,245	169,575	169,245	169,575	170,205	170,205	170,205	170,205
L3	112,83	113,05	112,83	113,05	113,47	113,47	113,47	113,47
L4	112,83	113,05	112,83	113,05	113,47	113,47	113,47	113,47
L5	169,245	169,575	169,245	169,575	170,205	170,205	170,205	170,205
L6	169,245	169,575	169,245	169,575	170,205	170,205	170,205	170,205
L7	112,83	113,05	112,83	113,05	113,47	113,47	113,47	113,47
L8	112,83	113,05	112,83	113,05	113,47	113,47	113,47	113,47

➤ **Weights with 2 pumps (to be added to Free Cooling STD weight)**

MODEL	045FS	045FL	050FS	050FL	060FS	060FL	070FS	070FL
FRAME	1	2	1	2	2	2	2	2
<b>Total [kg]</b>	<b>173,7</b>	<b>197,7</b>	<b>173,7</b>	<b>197,7</b>	<b>204,7</b>	<b>204,7</b>	<b>204,7</b>	<b>204,7</b>
L1	52,11	34,5975	52,11	34,5975	35,8225	35,8225	35,8225	35,8225
L2	52,11	34,5975	52,11	34,5975	35,8225	35,8225	35,8225	35,8225
L3	34,74	29,655	34,74	29,655	30,705	30,705	30,705	30,705
L4	34,74	29,655	34,74	29,655	30,705	30,705	30,705	30,705
L5		34,5975		34,5975	35,8225	35,8225	35,8225	35,8225
L6		34,5975		34,5975	35,8225	35,8225	35,8225	35,8225
L7								
L8								
MODEL	080FS	080FL	090FS	090FL	105FS	0105FL	115FS	115FL
FRAME	2	3	3	4	3	4	4	4
<b>Total [kg]</b>	<b>204,7</b>	<b>208,6</b>	<b>213,9</b>	<b>217,8</b>	<b>213,9</b>	<b>217,8</b>	<b>222,2</b>	<b>222,2</b>
L1	35,8225	36,505	37,4325	32,67	37,4325	32,67	33,33	33,33
L2	35,8225	36,505	37,4325	32,67	37,4325	32,67	33,33	33,33
L3	30,705	31,29	32,085	21,78	32,085	21,78	22,22	22,22
L4	30,705	31,29	32,085	21,78	32,085	21,78	22,22	22,22
L5	35,8225	36,505	37,4325	32,67	37,4325	32,67	33,33	33,33
L6	35,8225	36,505	37,4325	32,67	37,4325	32,67	33,33	33,33
L7				21,78		21,78	22,22	22,22
L8				21,78		21,78	22,22	22,22

MODEL	130FS	130FL	150FS	150FL	180FS	180FL	205FS	205FL
FRAME	4	4	4	5	5	5	5	5
Total [kg]	222,2	222,2	222,2	224,1	231,3	231,3	231,3	231,3
L1	33,33	33,33	33,33	33,615	34,695	34,695	34,695	34,695
L2	33,33	33,33	33,33	33,615	34,695	34,695	34,695	34,695
L3	22,22	22,22	22,22	22,41	23,13	23,13	23,13	23,13
L4	22,22	22,22	22,22	22,41	23,13	23,13	23,13	23,13
L5	33,33	33,33	33,33	33,615	34,695	34,695	34,695	34,695
L6	33,33	33,33	33,33	33,615	34,695	34,695	34,695	34,695
L7	22,22	22,22	22,22	22,41	23,13	23,13	23,13	23,13
L8	22,22	22,22	22,22	22,41	23,13	23,13	23,13	23,13
MODEL	220FS	220FL	235FS	235FL	250FS	250FL	280FS	300FS
FRAME	5	6	5	6	6	6	6	6
Total [kg]	231,3	233,5	231,3	233,5	237,7	237,7	237,7	237,7
L1	34,695	35,025	34,695	35,025	35,655	35,655	35,655	35,655
L2	34,695	35,025	34,695	35,025	35,655	35,655	35,655	35,655
L3	23,13	23,35	23,13	23,35	23,77	23,77	23,77	23,77
L4	23,13	23,35	23,13	23,35	23,77	23,77	23,77	23,77
L5	34,695	35,025	34,695	35,025	35,655	35,655	35,655	35,655
L6	34,695	35,025	34,695	35,025	35,655	35,655	35,655	35,655
L7	23,13	23,35	23,13	23,35	23,77	23,77	23,77	23,77
L8	23,13	23,35	23,13	23,35	23,77	23,77	23,77	23,77

➤ Weights with 1 pump (to be added to Free Cooling STD weight)

MODEL	045FS	045FL	050FS	050FL	060FS	060FL	070FS	070FL
FRAME	1	2	1	2	2	2	2	2
Total [kg]	139,2	163,2	139,2	163,2	168,4	168,4	168,4	168,4
L1	41,76	28,56	41,76	28,56	29,47	29,47	29,47	29,47
L2	41,76	28,56	41,76	28,56	29,47	29,47	29,47	29,47
L3	27,84	24,48	27,84	24,48	25,26	25,26	25,26	25,26
L4	27,84	24,48	27,84	24,48	25,26	25,26	25,26	25,26
L5		28,56		28,56	29,47	29,47	29,47	29,47
L6		28,56		28,56	29,47	29,47	29,47	29,47
L7								
L8								
MODEL	080FS	080FL	090FS	090FL	105FS	0105FL	115FS	115FL
FRAME	2	3	3	4	3	4	4	4
Total [kg]	168,4	172,3	175,9	179,7	175,9	179,7	182,3	182,3
L1	29,47	30,1525	30,7825	26,955	30,7825	26,955	27,345	27,345
L2	29,47	30,1525	30,7825	26,955	30,7825	26,955	27,345	27,345
L3	25,26	25,845	26,385	17,97	26,385	17,97	18,23	18,23
L4	25,26	25,845	26,385	17,97	26,385	17,97	18,23	18,23
L5	29,47	30,1525	30,7825	26,955	30,7825	26,955	27,345	27,345
L6	29,47	30,1525	30,7825	26,955	30,7825	26,955	27,345	27,345
L7				17,97		17,97	18,23	18,23
L8				17,97		17,97	18,23	18,23
MODEL	130FS	130FL	150FS	150FL	180FS	180FL	205FS	205FL
FRAME	4	4	4	5	5	5	5	5
Total [kg]	182,3	182,3	182,3	184,1	189,6	189,6	189,6	189,6
L1	27,345	27,345	27,345	27,615	28,44	28,44	28,44	28,44
L2	27,345	27,345	27,345	27,615	28,44	28,44	28,44	28,44
L3	18,23	18,23	18,23	18,41	18,96	18,96	18,96	18,96
L4	18,23	18,23	18,23	18,41	18,96	18,96	18,96	18,96
L5	27,345	27,345	27,345	27,615	28,44	28,44	28,44	28,44
L6	27,345	27,345	27,345	27,615	28,44	28,44	28,44	28,44
L7	18,23	18,23	18,23	18,41	18,96	18,96	18,96	18,96
L8	18,23	18,23	18,23	18,41	18,96	18,96	18,96	18,96
MODEL	220FS	220FL	235FS	235FL	250FS	250FL	280FS	300FS
FRAME	5	6	5	6	6	6	6	6
Total [kg]	189,6	191,8	189,6	191,8	194,2	194,2	194,2	194,2
L1	28,44	28,77	28,44	28,77	29,13	29,13	29,13	29,13
L2	28,44	28,77	28,44	28,77	29,13	29,13	29,13	29,13
L3	18,96	19,18	18,96	19,18	19,42	19,42	19,42	19,42
L4	18,96	19,18	18,96	19,18	19,42	19,42	19,42	19,42
L5	28,44	28,77	28,44	28,77	29,13	29,13	29,13	29,13
L6	28,44	28,77	28,44	28,77	29,13	29,13	29,13	29,13
L7	18,96	19,18	18,96	19,18	19,42	19,42	19,42	19,42
L8	18,96	19,18	18,96	19,18	19,42	19,42	19,42	19,42

### 13.5 WATER PUMPING AND STORAGE SYSTEMS

HWA units may be equipped with 4 types of pumping systems, complete with expansion tank, and inertial storage reservoirs:

- single standard pump
- single uprated pump
- standard pump and back-up pump
- uprated pump and back-up pump.

In the case of pump systems including a back-up pump, the microprocessor controls the pumps in such a way as to equally divide the hours of operation, changing over the pumps in the event of a fault.

HWA		045	050	060	070	080	090
Standard pump type		A	A	B	B	B	C
Available head, HWA with standard pump (nominal flow rate)	kPa	79	74	123	117	116	159
Rated electrical output, standard pump	kW	0.55	0.55	0.75	0.75	0.75	1.50
Operating current, standard pump	A	1.7	1.7	2.3	2.3	2.3	4.3
Uprated pump type		C	C	D	D	D	E
Available head, HWA with uprated pump (nominal flow rate)	kPa	183	178	138	224	221	229
Rated electrical output, uprated pump	kW	1.50	1.50	2.20	2.20	2.20	3.00
Operating current, uprated pump	A	4.3	4.3	5.3	5.3	5.3	6.6
Inertial storage reservoir capacity	dm <sup>3</sup>	218	218	315	315	315	485
Expansion tank	dm <sup>3</sup>	8	8	8	8	8	12
HWA		105	115	130	150	180	205
Standard pump type		C	C	C	D	D	E
Available head, HWA with standard pump (nominal flow rate)	kPa	137	131	126	143	138	146
Rated electrical output, standard pump	kW	1.50	1.50	1.50	2.20	2.20	3.00
Operating current, standard pump	A	4.3	4.3	4.3	5.3	5.3	6.6
Uprated pump type		E	F	F	F	G	G
Available head, HWA with uprated pump (nominal flow rate)	kPa	217	264	258	238	279	281
Rated electrical output, uprated pump	kW	3.00	4.00	4.00	4.00	7.50	7.50
Operating current, uprated pump	A	6.6	9.6	9.6	9.6	16.0	16.0
Inertial storage reservoir capacity	dm <sup>3</sup>	485	600	600	600	600	765
Expansion tank	dm <sup>3</sup>	12	24	24	24	24	24
HWA		220	235	250	280	300	
Standard pump type		E	E	F	F	F	
Available head, HWA with standard pump (nominal flow rate)	kPa	139	131	174.9	168.9	156.2	
Rated electrical output, standard pump	kW	3.00	3.00	4.00	4.00	4.00	
Operating current, standard pump	A	6.6	6.6	9.2	9.2	9.2	
Uprated pump type		G	G	H	H	H	
Available head, HWA with uprated pump (nominal flow rate)	kPa	278	261	292.6	286.6	273.9	
Rated electrical output, uprated pump	kW	7.50	7.50	7.50	7.50	7.50	
Operating current, uprated pump	A	16.0	16.0	15.5	15.5	15.5	
Inertial storage reservoir capacity	dm <sup>3</sup>	765	765	765	765	765	
Expansion tank	dm <sup>3</sup>	24	24	24	24	24	

