

MATRIX[®] FILTER

SERIES D

600 Volts, 60HZ

USER MANUAL

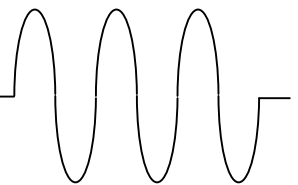

PART NO. INSTR -026

REL. 120628

REV. 007

© 2012 MTE Corporation

IMPORTANT USER INFORMATION

NOTICE

The MTE Corporation Matrix[®] Filter is designed for harmonic mitigation of six pulse inverter drives supplying variable torque loads in a wide variety of applications. The suitability of this filter for a specific application must therefore be determined by the customer. In no event will MTE Corporation assume responsibility or liability for any direct or consequential damages resulting from the use or application of this filter. Nor will MTE Corporation assume patent liability with respect to the use of information, circuits or equipment described in this instruction manual. The series D Matrix Filter uses patented Harmonics Mitigating Reactor (HMR) technology to limit full load current distortion to less than 5% THID.



MDG0403E

TABLE OF CONTENTS

IMPORTANT USER INFORMATION..... 1

TABLE OF CONTENTS 2

IMPORTANT SAFETY INFORMATION..... 3

INTRODUCTION 5

PART NUMBER CODES..... 6

SPECIFICATIONS: 7

 AGENCY APPROVALS..... 7

RATINGS 8

 WATTS LOSS..... 8

 REGULATION TABLE 9

 CAPACITOR CURRENTS 10

 OVER TEMPERATURE SWITCH RATINGS 11

OPEN STYLE SIZE AND WEIGHTS 12

ENCLOSED UNIT SIZE AND WEIGHTS..... 13

PERFORMANCE DATA..... 14

 LOAD EFFECT ON THID..... 14

 HARMONIC SPECTRUM 100% LOAD..... 14

 POWER FACTOR..... 15

 PERFORMANCE WITH UNBALANCED LINE VOLTAGE (TYPICAL)..... 15

 ALTITUDE DE-RATING CURVE 16

 TEMPERATURE DE-RATING CURVE 16

INSTALLATION INSTRUCTIONS 17

 HMR BOLT HOLE MOUNTING PATTERNS..... 18

 CAP-PANEL BOLT HOLE MOUNTING PATTERNS 19

 HMR MOUNTING & TERMINAL LOCATIONS 20

HMR 6 - 11 Amps..... 20

HMR 14 -34 Amp 21

HMR 44 - 83 Amp 22

HMR 103 - 208 Amp 23

HMR 240 - 786 Amp 24

HMR 850 - 1200 Amp 25

 CAP-ASSEMBLY MOUNTING & TERMINAL LOCATIONS..... 26

 ENCLOSED UNIT INTERNAL DETAILS & TERMINAL LOCATIONS 28

CAB-12C 6-34 AMPS..... 28

CAB-17C 44-66 AMPS..... 29

CAB-26C 83-208 AMPS..... 30

CAB-26D 240-403 AMPS..... 31

CAB-30D 482-636 AMPS..... 32

CAB-42D 786 AMPS..... 33

POWER WIRING CONNECTION 34

 INPUT AND OUTPUT TERMINAL SPECIFICATIONS..... 36

 OPEN PANEL UNIT INTERCONNECTION DIAGRAM 37

 ENCLOSED UNIT INTERCONNECTION DIAGRAM..... 38

FILTER DESCRIPTION..... 39

 BLOCK DIAGRAM 40

 MATRIX D BASIC SCHEMATIC DIAGRAM..... 41

 CONTACTOR COIL SWITCHING CURRENTS 48

 STARTUP 49

 SAFETY PRECAUTIONS 49

 SEQUENCE OF OPERATION 49

TROUBLESHOOTING 50

 MTE MATRIX FILTER FIELD CHECKS..... 51

IMPORTANT SAFETY INFORMATION



WARNING

ONLY A QUALIFIED ELECTRICIAN CAN CARRY OUT THE ELECTRICAL INSTALLATION OF THIS FILTER



WARNING

High voltage is used in the operation of this filter. Use Extreme caution to avoid contact with high voltage when operating, installing or repairing this filter.

INJURY OR DEATH MAY RESULT IF SAFETY PRECAUTIONS ARE NOT OBSERVED.

After removing power, allow at least five minutes to elapse and verify that the capacitors have discharged to a safe level before contacting internal components. Connect a DC voltmeter across the capacitor terminals. Start with the meter on the highest scale and progressively switch to a lower scale as the indicated voltage falls below the maximum value of the scale used.



WARNING

The opening of the branch circuit protective device may be an indication that a fault current has been interrupted. To reduce the risk of fire or electrical shock, current-carrying parts and other components of the filter should be examined and replaced if damaged.



WARNING

An upstream disconnect/protection device must be used as required by the National Electrical Code (NEC) or governing authority.

IMPORTANT SAFETY INFORMATION, CONT.



WARNING

Even if the upstream disconnect/protection device is open, the drive down stream of the filter may feed back high voltage to the filter. The drive safety instructions must be followed.

INJURY OR DEATH MAY RESULT IF SAFETY PRECAUTIONS ARE NOT OBSERVED



WARNING

The filter must be grounded with a grounding conductor connected to all grounding terminals.



WARNING

Only spare parts obtained from MTE Corporation or an authorized MTE distributor can be used.



WARNING

Loose or improperly secured connections may damage or degrade filter performance. Visually inspect and secure all electrical connections before loading the filter.

Introduction

This manual was specifically developed to assist in the installation, interconnection and operation of the MTE Corporation "Series D" Matrix Filter.

This manual is intended for use by personnel experienced in the operation and maintenance of electronic drives. Because of the high voltages required by the filter and drive and the potential dangers presented by rotating machinery, it is essential that all personnel involved in the operation and maintenance of this filter know and practice the necessary safety precautions for this type of equipment. Personnel should read and understand the instructions contained in this manual before installing, operating or servicing the filter and the drive to which the filter is connected.

Upon Receipt of this Filter:

The MTE Matrix Filter has been subjected to demanding factory tests before shipment. Carefully inspect the shipping container for damage that may have occurred in transit. Then unpack the filter and carefully inspect for any signs of damage. Save the shipping container for future transport of the filter.

In the event of damage, please contact and file a claim with the freight carrier involved immediately.

If the equipment is not going to be put into service upon receipt, cover and store the filter in a clean, dry location. After storage, ensure that the equipment is dry and that no condensation or dirt has accumulated on the internal components of the filter before applying power.

Repair/Exchange Procedure

MTE Corporation requires a Returned Material Authorization Number before it can accept any filters that qualify for return or repair. If problems or questions arise during installation, setup, or operation of the filter, please call the Director of Corporate Quality for assistance at:

Phone: 262-253-8200 ext. 148

FAX: 858-300-5070

PART NUMBER CODES

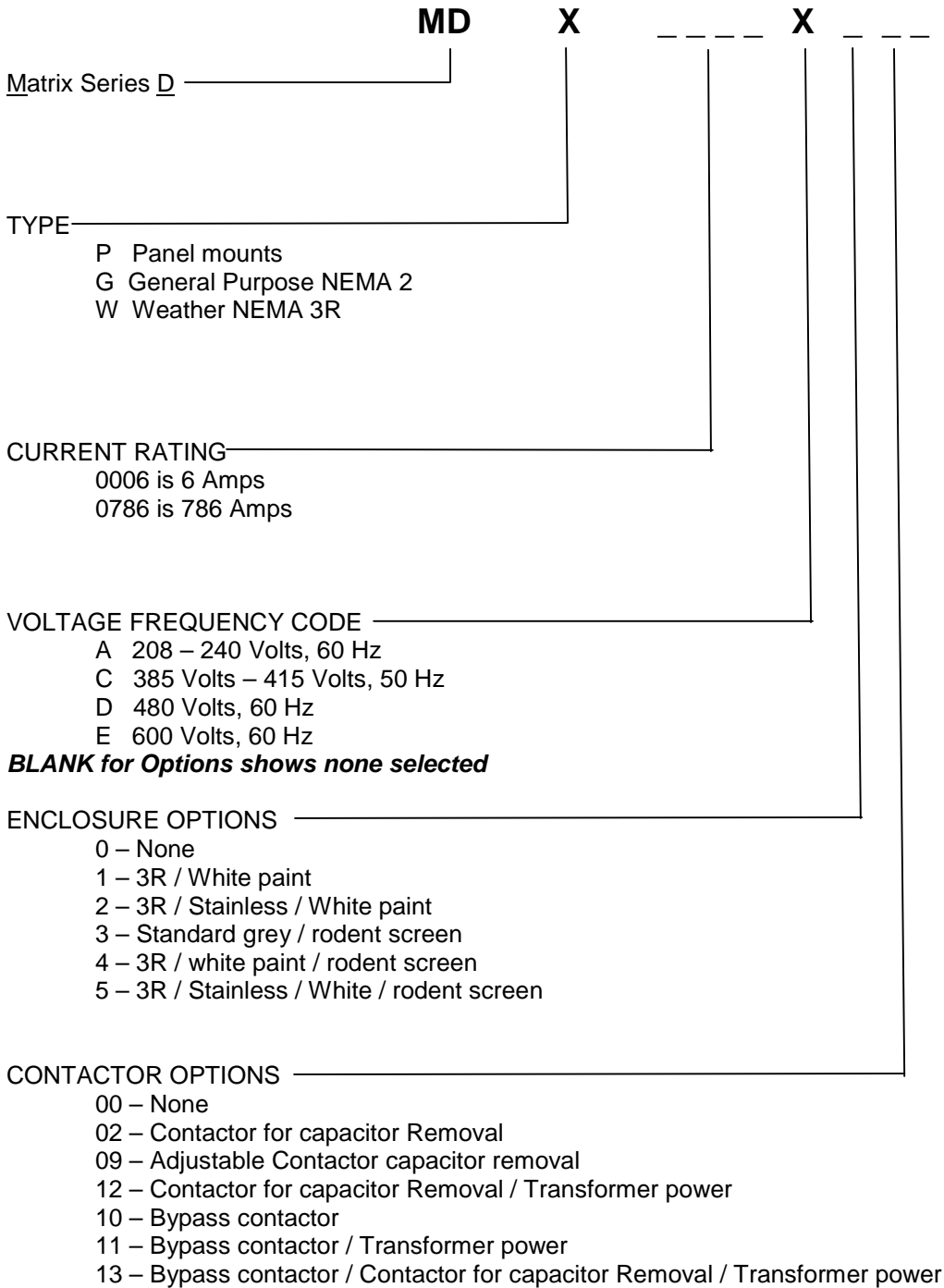

Specifications:

Service Conditions

Load: 6 pulse variable torque rectifier only

Input voltage: 600 VAC +/- 10%, 60 ± 0.75 Hz, 3 phase

Input voltage line unbalance: 1% maximum

Maximum source impedance: 6.00%

Minimum source impedance: 1.5%

Service Factor: 1.00

Overload: 150 % for 1 minute duration with 10% output voltage reduction of nominal of voltage.

Ambient Temperature (Operating)

Enclosed Filters:	-40 to +40 degrees C
Open Panel Filters:	-40 to +50 degrees C
Storage Temperature:	-40 to +90 degrees C

Altitude: 0 to 3300 Feet above sea level. Refer to figure 4 for altitude de-rating.

Relative Humidity: 0 to 95% non-condensing

Agency Approvals

UL and cUL listed to UL508 Type MX and CSA-C22.2 No 14-95
File E180243 (3 – 1000 HP, 120VAC through 600 VAC
50, 50/60, 60 Hz Three Phase

Notes (SCCR):

- 1. The Short Circuit Current Rating (SCCR) is not required under Exception No.1 of UL508A SB4.2.1 effective 4/25/06. This exception also applies to all the Contactor Options (002, 009, 012, and similar), where the Contactors are separated from the Main Power path by exempt components (such as Reactors) of sufficient Impedance, which is assured in case of the Reactors that are integral components of our Filter.*
- 2. The SCCR of Matrix Harmonic Filters with the Bypass Options (010, 011, 013, and similar) is determined by the rating of the Bypass Contactor, if the Contactor is supplied by MTE. These Options use Eaton (Cutler-Hammer) Freedom Series Contactors. The Contactors are UL certified as IEC Type 2, and have the SCCR of 100,000 Amps, when protected by appropriate Current Limiting Fuses (or Fast Acting Breaker of similar characteristics), such upstream branch protection devices being supplied and installed by Others. Customer's election to substitute their own Contactor for MTE's Standard, renders such Contactor separate from the Filter and thus has no impact on the Filter Rating Exemption Status.*

Performance

Total Harmonic Current Distortion:

Five Percent Filter: 5% MAX at FULL LOAD

Standby Current:

Without Optional Capacitor Contactor: 70% of the full load capacitor current listed in Table 3

With Optional Capacitor Contactor: Refer to Drive User's Manual

Ratings

Watts loss

Table 1

Maximum Output Amps RMS	Efficiency (Typical) (%)	Power Dissipation @ Rated Current (Typical) (Watts)
6	97.4	132
8	97.6	161
11	97.8	197
14	98.0	232
21	98.3	294
27	98.5	343
34	98.6	399
44	98.7	472
52	98.8	533
66	98.9	621
83	98.9	735
103	99.0	844
128	99.1	959
165	99.2	1143
208	99.2	1355
240	99.2	1493
320	99.3	1829
403	99.4	2194
482	99.4	2214
636	99.4	3091
786	99.5	3192

Regulation table
Table 2

FILTER VOLTAGE REGULATION		600 VAC
MAXIMUM OUTPUT VOLTAGE AT NO LOAD	RMS PEAK	627 885
MINIMUM OUTPUT VOLTAGE AT FULL LOAD	RMS PEAK	575 750
*MAXIMUM PCC VOLTAGE WITH 6% SOURCE IMPEDANCE	RMS PEAK	612 864

Note: PCC is the point of common coupling with the power distribution system

Capacitor Currents
 Table 3

Capacitor Current at Full Load	
Filter Current Rating Amps RMS	Capacitor Current (Typical) Amps RMS
6	2.3
8	3.1
11	4.2
14	5.4
21	8.1
27	10.4
34	13.1
44	16.9
52	20.0
66	25.3
83	31.9
103	39.6
128	49.2
165	63.4
208	79.9
240	92.2
320	122.9
403	154.8
482	185.1
636	244.2
786	301.8

Over Temperature Switch Ratings

Table 6

<i>NC Switch</i> opens at 180 Deg. +/- 5 deg C		
Current Amps	Voltage	Contact Load
6	120 AC	Resistive Loads
3	120 AC	Inductive Loads
3	240 AC	Resistive Loads
2.5	240 AC	Inductive Loads
8	12 VDC	Resistive Loads
4	24 VDC	Resistive Loads

Open Style Size and Weights

Table 4

Amps rating	Catalog Part Number	Total Weight Lbs.	HMR Size Inches	HMR Ref. Figure	Cap-Panel P.N.	Capacitor assemblies size Inches	Cap Ref. Figure
6	MDP0006E	18	11.3"H x 6"W x 6.2"D	Figure 5	242	5.6"H x 5.6"W x 9.3"D	Figure 12
8	MDP0008E	20	12.3"H x 7.3"W x 5.8"D	Figure 5	243	5.6"H x 5.6"W x 9.3"D	Figure 12
11	MDP0011E	25	12.3"H x 7.3"W x 6.1"D	Figure 5	201	5.6"H x 5.6"W x 7.3"D	Figure 12
14	MDP0014E	32	15.8"H x 9"W x 6.5"D	Figure 6	202	5.6"H x 5.6"W x 8.2"D	Figure 12
21	MDP0021E	42	15.8"H x 9"W x 7"D	Figure 6	244	5.6"H x 5.6"W x 9.3"D	Figure 12
27	MDP0027E	59	15.8"H x 9"W x 7.5"D	Figure 6	204	5.6"H x 5.6"W x 7.3"D	Figure 12
34	MDP0034E	70	15.8"H x 9"W x 8"D	Figure 6	205	5.6"H x 5.6"W x 8.2"D	Figure 12
44	MDP0044E	80	16.5"H x 12.3"W x 9.4"D	Figure 7	245	8"H x 9.1"W x 12"D	Figure 13
52	MDP0052E	124	16.5"H x 12.3"W x 10.4"D	Figure 7	246	8"H x 9.1"W x 12"D	Figure 13
66	MDP0066E	149	16.5"H x 12.3"W x 11.3"D	Figure 7	247	8"H x 9.1"W x 12"D	Figure 13
83	MDP0083E	173	16.5"H x 12.3"W x 11.6"D	Figure 7	248	12"H x 9.1"W x 12"D	Figure 14
103	MDP0103E	178	22.9"H x 15.5"W x 11.5"D	Figure 8	249	12"H x 9.1"W x 12"D	Figure 14
128	MDP0128E	210	22.9"H x 15.5"W x 11.9"D	Figure 8	250	15"H x 9.1"W x 12"D	Figure 15
165	MDP0165E	289	27.4"H x 15.5"W x 13.4"D	Figure 8	250	15"H x 9.1"W x 12"D	Figure 15
					251	5.6"H x 5.6"W x 9.3"D	Figure 12
208	MDP0208E	278	27.4"H x 15.5"W x 12.3"D	Figure 8	252	15"H x 9.1"W x 12"D	Figure 15
					253	8"H x 9.1"W x 12"D	Figure 13
240	MDP0240E	296	35.5"H x 16.5"W x 24"D	Figure 9	252	15"H x 9.1"W x 12"D	Figure 15
					254	12"H x 9.1"W x 12"D	Figure 14
320	MDP0320E	453	35.5"H x 22.5"W x 24"D	Figure 9	252	15"H x 9.1"W x 12"D	Figure 15
					252	15"H x 9.1"W x 12"D	Figure 13
					255	5.6"H x 5.6"W x 9.3"D	Figure 12
403	MDP0403E	494	35.5"H x 22.5"W x 24"D	Figure 9	256	15"H x 9.1"W x 12"D	Figure 15
					257	15"H x 9.1"W x 12"D	Figure 15
482	MDP0482E	583	35.5"H x 22.5"W x 24"D	Figure 9	256	15"H x 9.1"W x 12"D	Figure 15
					256	15"H x 9.1"W x 12"D	Figure 15
					258	12"H x 9.1"W x 12"D	Figure 14
					259	12"H x 9.1"W x 12"D	Figure 14
636	MDP0636E	834	35.5"H x 22.5"W x 25"D	Figure 9	252	15"H x 9.1"W x 12"D	Figure 15
					252	15"H x 9.1"W x 12"D	Figure 15
					252	15"H x 9.1"W x 12"D	Figure 15
					246	8"H x 9.1"W x 12"D	Figure 13
786	MDP0786E	1072	35.5"H x 22.5"W x 25.3"D	Figure 9	260	15"H x 9.1"W x 12"D	Figure 15
					260	15"H x 9.1"W x 12"D	Figure 15
					260	15"H x 9.1"W x 12"D	Figure 15
					261	15"H x 9.1"W x 12"D	Figure 12
					261	15"H x 9.1"W x 12"D	Figure 16
					262	8"H x 9.1"W x 12"D	Figure 13

Enclosed Unit Size and Weights

Table 5

Filter Amps	NEMA 2	Enclosure	Weight	NEMA 3R	Enclosure	Weight	Figure
6	MDG0006E	CAB-12C2	76	MDW0006E	CAB-12C3	86	Figure 17
8	MDG0008E	CAB-12C2	79	MDW0008E	CAB-12C3	89	Figure 17
11	MDG0011E	CAB-12C2	83	MDW0011E	CAB-12C3	93	Figure 17
14	MDG0014E	CAB-12C2	90	MDW0014E	CAB-12C3	100	Figure 17
21	MDG0021E	CAB-12C2	100	MDW0021E	CAB-12C3	110	Figure 17
27	MDG0027E	CAB-12C2	117	MDW0027E	CAB-12C3	127	Figure 17
34	MDG0034E	CAB-12C2	128	MDW0034E	CAB-12C3	138	Figure 17
44	MDG0044E	CAB-17C2	159	MDW0044E	CAB-17C3	168	Figure 18
52	MDG0052E	CAB-17C2	197	MDW0052E	CAB-17C3	206	Figure 18
66	MDG0066E	CAB-17C2	222	MDW0066E	CAB-17C3	231	Figure 18
83	MDG0083E	CAB-26C2	354	MDW0083E	CAB-26C3	375	Figure 19
103	MDG0103E	CAB-26C2	357	MDW0103E	CAB-26C3	378	Figure 19
128	MDG0128E	CAB-26C2	394	MDW0128E	CAB-26C3	415	Figure 19
165	MDG0165E	CAB-26C2	466	MDW0165E	CAB-26C3	487	Figure 19
208	MDG0208E	CAB-26C2	481	MDW0208E	CAB-26C3	502	Figure 19
240	MDG0240E	CAB-26D2	526	MDW0240E	CAB-26D3	658	Figure 20
320	MDG0320E	CAB-26D2	686	MDW0320E	CAB-26D3	817	Figure 20
403	MDG0403E	CAB-26D2	737	MDW0403E	CAB-26D3	868	Figure 20
482	MDG0482E	CAB-30D2	970	MDW0482E	CAB-30D3	1012	Figure 21
636	MDG0636E	CAB-30D2	1244	MDW0636E	CAB-30D3	1286	Figure 21
786	MDG0786E	CAB-42D2	1545	MDW0786E	CAB-42D3	1610	Figure 22

Note: Weight is shown in pounds

Performance Data

Figure 1
Load effect on THID

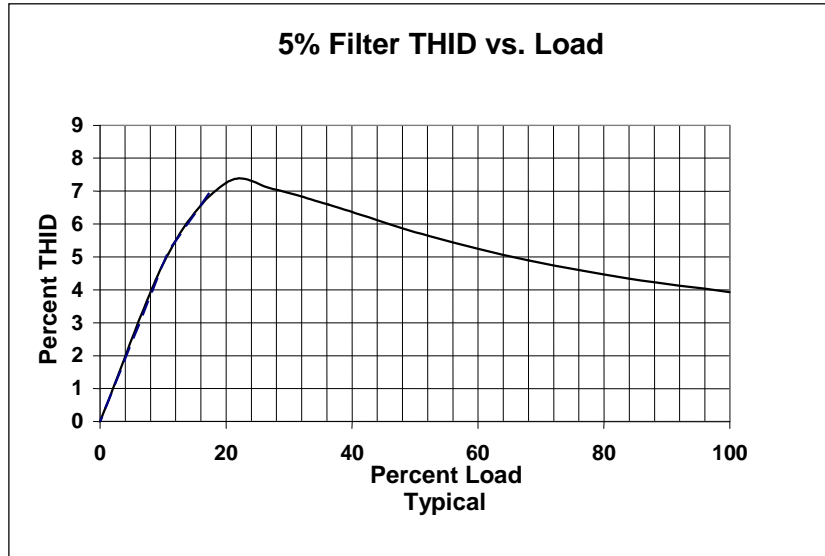

Figure 2
Harmonic Spectrum 100% Load

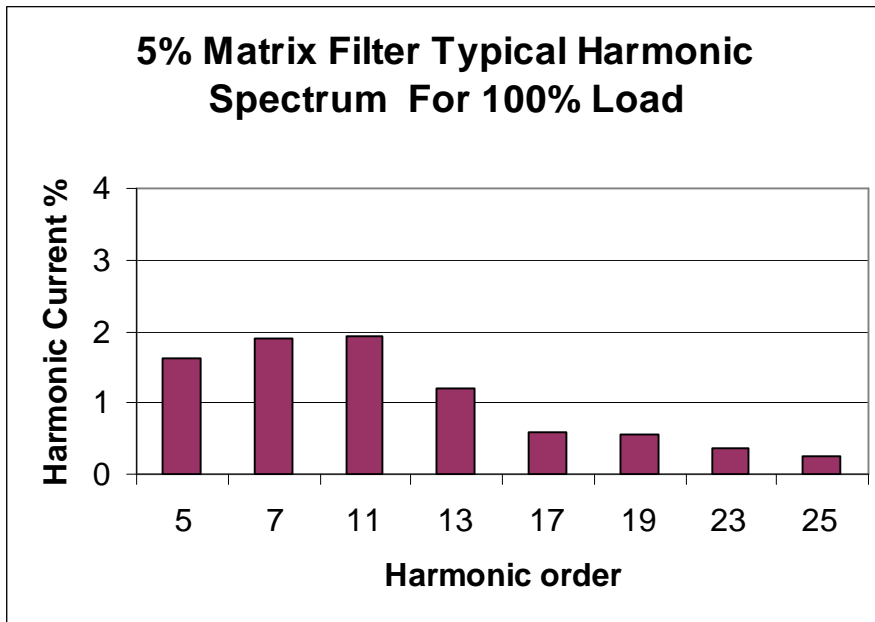
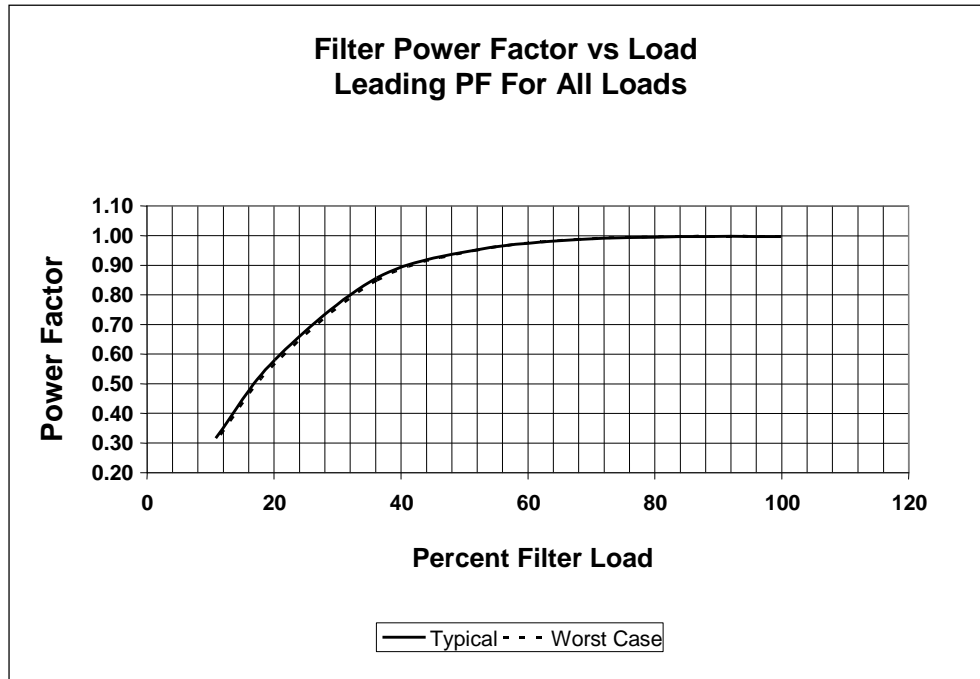

Figure 3
Power Factor



Performance with Unbalanced Line Voltage (Typical)

Table 7

All Components at Nominal Values and Worse Case Service Conditions	
100% Load	
Nominal THID	3.93%
1% Unbalance	4.06%
2% Unbalance	4.47%
3% Unbalance	5.10%
30% Load	
Nominal THID	7.06%
1% Unbalance	7.45%
2% Unbalance	8.21%
3% Unbalance	10.46%

Altitude De-rating Curve

Figure 4

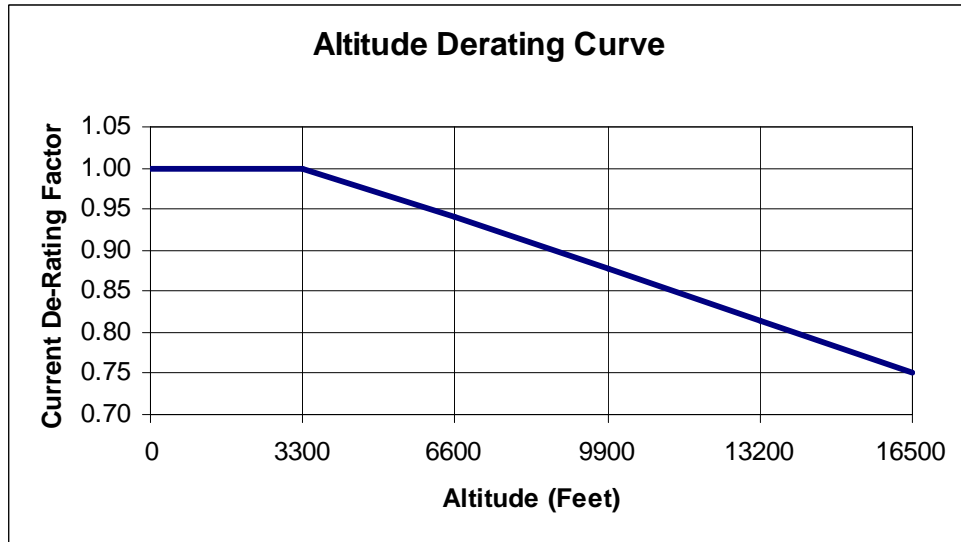

Temperature De-rating Curve

Figure 4A

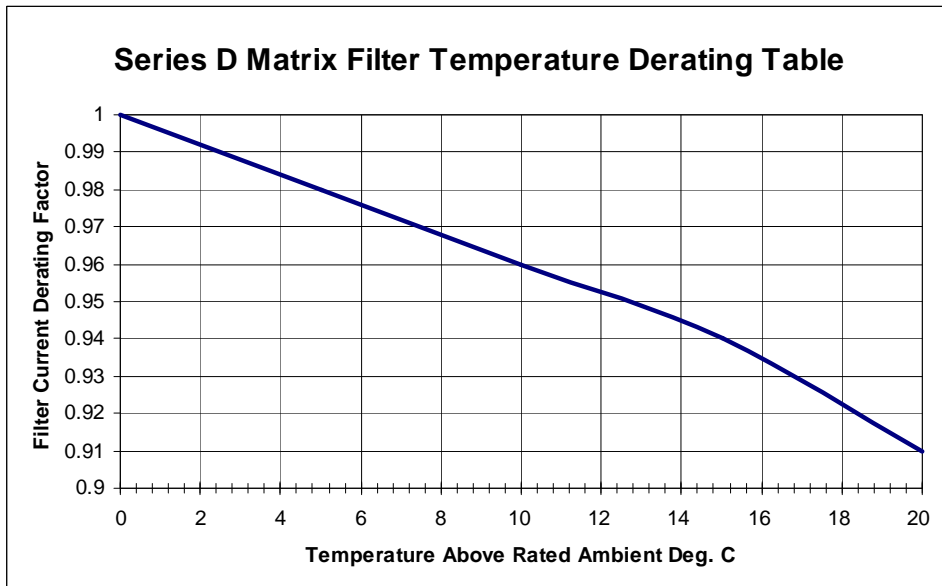

Note: Contact factory if Ambient is 20 °C above temperature rating.
 See or click [Specifications](#) for temperature ratings

INSTALLATION INSTRUCTIONS

Matrix Filters are supplied in the following mechanical configurations:

Panel mounted assemblies

Floor mounted general purpose NEMA 2, & 3R cabinets,

Select a well-ventilated, dust-free area away from direct sunlight, rain or moisture. Do not install in or near a corrosive environment. Avoid locations where the filter would be subjected to excessive vibrations.

Panel mounted filters are designed for mounting in the vertical plane within the customer's enclosure. Panel mount units are made up of a Harmonic Mitigating Reactor (HMR) and one or more capacitor panel assemblies referred to as cap-panels on drawings and diagrams.

Mount the Harmonic Mitigating Reactor in a location where the ambient temperature does not exceed 50 degrees C. Allow a minimum side clearance of four (4) inches and a vertical clearance of six (6) inches for proper heat dissipation and access.



WARNING

Do not install capacitor assembly above/near resistors and Harmonic Mitigating Reactor. Premature or catastrophic failure may occur.

The capacitor assembly must be located in the lowest temperature regions of the enclosure - generally toward the bottom and away from high temperature components.



Figure's 5 - 22 contain outline drawings for the various ratings and show mounting orientation with bolt patterns.

Include the power dissipation of the filter along with all the other components located in the enclosure to determine the internal temperature rise and cooling requirements of the enclosure.

General purpose NEMA 2, and 3R enclosed filters are designed for floor mounting in the vertical plane in an environment suitable for the enclosure type. Do not install in or near a corrosive environment. Avoid locations where the filter would be subjected to excessive vibrations. Allow a minimum side and back clearance of eight (8) inches and front clearance of thirty-six (36) inches for proper heat dissipation and access.

Refer to Article 430 Table 430.91 of the National Electrical code for the selection of the appropriate enclosure Type Number for your application.

HMR Bolt Hole Mounting Patterns

Table 8

Part Number	Lbs.	Overall Size	Rear Mount Centerline	Base Mount Centerline	Mounting Holes	Figure
MDP0006E	14	11.3"H x 6"W x 6.2"D	10.25"A x 5"B	3"C x 2.5"E	0.281 DIA	Figure 5
MDP0008E	16	12.3"H x 7.3"W x 5.8"D	11.38"A x 5"B	3"C x 2.5"E	0.281 DIA	Figure 5
MDP0011E	21	12.3"H x 7.3"W x 6.1"D	11.38"A x 5"B	3"C x 2.75"E	0.281 DIA	Figure 5
MDP0014E	26	15.8"H x 9"W x 6.5"D	14.25"A x 6"B	4.26"C x 2.88"E	0.358 DIA	Figure 5
MDP0021E	42	15.8"H x 9"W x 7"D	14.25"A x 6"B	4.26"C x 3.66"E	0.358 DIA	Figure 5
MDP0027E	51	15.8"H x 9"W x 7.5"D	14.25"A x 6"B	4.26"C x 4.16"E	0.358 DIA	Figure 5
MDP0034E	61	15.8"H x 9"W x 8"D	14.25"A x 6"B	4.26"C x 4.66"E	0.358 DIA	Figure 5
MDP0044E	71	16.5"H x 12.3"W x 9.4"D	12.25"A x 11"B	11"C x 6.5"E	0.413 DIA	Figure 5
MDP0052E	80	16.5"H x 12.3"W x 10.4"D	12.14"A x 11"B	11"C x 6.5"E	0.413 DIA	Figure 6
MDP0066E	90	16.5"H x 12.3"W x 11.3"D	12.25"A x 11"B	11"C x 6.5"E	0.413 DIA	Figure 6
MDP0083E	101	16.5"H x 12.3"W x 11.6"D	12.25"A x 11"B	11"C x 6.5"E	0.413 DIA	Figure 6
MDP0103E	125	22.9"H x 15.5"W x 11.5"D	17.83"A x 14"B	14"C x 8"E	0.413 DIA	Figure 6
MDP0128E	150	22.9"H x 15.5"W x 11.9"D	17.86"A x 14"B	14"C x 8"E	0.413 DIA	Figure 7
MDP0165E	200	27.4"H x 15.5"W x 13.4"D	17.14"A x 14"B	14"C x 8"E	0.413 DIA	Figure 7
MDP0208E	250	27.4"H x 15.5"W x 12.3"D	17.12"A x 14"B	14"C x 8"E	0.413 DIA	Figure 7
MDP0240E	275	35.5"H x 16.5"W x 24"D	31"A x 16.5"B	16.5"C x 17.5"E	0.413 DIA	Figure 7
MDP0320E	375	35.5"H x 22.5"W x 24"D	31"A x 22.5"B	22.5"C x 17.5"E	0.413 DIA	Figure 8
MDP0403E	480	35.5"H x 22.5"W x 24"D	31"A x 22.5"B	22.5"C x 17.5"E	0.413 DIA	Figure 8
MDP0482E	560	35.5"H x 22.5"W x 24"D	31"A x 22.5"B	22.5"C x 17.5"E	0.413 DIA	Figure 8
MDP0636E	725	35.5"H x 22.5"W x 25"D	31"A x 22.5"B	22.5"C x 17.5"E	0.413 DIA	Figure 9
MDP0786E	900	35.5"H x 22.5"W x 25.3"D	31"A x 22.5"B	22.5"C x 17.5"E	0.413 DIA	Figure 9

Use the above table and referenced figures to establish suitable reactor mounting.

Cap-panel Bolt Hole Mounting Patterns

Table 9

Part Number	CAP P.N.	Cap-panel Weight Lbs.	Overall Size	Rear Mount Centerline	Mounting Holes	Figure
MDP0006E	242	3.75	5.6"H x 5.6"W x 9.3"D	5.06"A x 5.06"B	0.218	Figure 12
MDP0008E	243	3.75	5.6"H x 5.6"W x 9.3"D	5.06"A x 5.06"B	0.218	Figure 12
MDP0011E	201	3.75	5.6"H x 5.6"W x 7.3"D	5.06"A x 5.06"B	0.218	Figure 12
MDP0014E	202	3.75	5.6"H x 5.6"W x 8.2"D	5.06"A x 5.06"B	0.218	Figure 12
MDP0021E	244	3.75	5.6"H x 5.6"W x 9.3"D	5.06"A x 5.06"B	0.218	Figure 12
MDP0027E	204	3.75	5.6"H x 5.6"W x 7.3"D	5.06"A x 5.06"B	0.218	Figure 12
MDP0034E	205	3.75	5.6"H x 5.6"W x 8.2"D	5.06"A x 5.06"B	0.218	Figure 12
MDP0044E	245	7.5	8"H x 9.1"W x 12"D	7.25"A x 4.5"B	0.218	Figure 13
MDP0052E	246	7.5	8"H x 9.1"W x 12"D	7.25"A x 4.5"B	0.218	Figure 13
MDP0066E	247	7.5	8"H x 9.1"W x 12"D	7.25"A x 4.5"B	0.218	Figure 13
MDP0083E	248	11.25	12"H x 9.1"W x 12"D	11.25"A x 4.5"B	0.218	Figure 14
MDP0103E	249	11.25	12"H x 9.1"W x 12"D	11.25"A x 4.5"B	0.218	Figure 14
MDP0128E	250	15	15"H x 9.1"W x 12"D	14.25"A x 4.5"B	0.218	Figure 15
MDP0165E	250	15	15"H x 9.1"W x 12"D	14.25"A x 4.5"B	0.218	Figure 15
	251	3.75	5.6"H x 5.6"W x 9.3"D	5.06"A x 5.06"B	0.218	Figure 12
MDP0208E	252	15	15"H x 9.1"W x 12"D	14.25"A x 4.5"B	0.218	Figure 15
	253	7.5	8"H x 9.1"W x 12"D	7.25"A x 4.5"B	0.218	Figure 13
MDP0240E	252	15	15"H x 9.1"W x 12"D	14.25"A x 4.5"B	0.218	Figure 15
	254	11.25	12"H x 9.1"W x 12"D	11.25"A x 4.5"B	0.218	Figure 14
MDP0320E	252	15	15"H x 9.1"W x 12"D	14.25"A x 4.5"B	0.218	Figure 15
	252	15	15"H x 9.1"W x 12"D	14.25"A x 4.5"B	0.218	Figure 15
	255	3.75	5.6"H x 5.6"W x 9.3"D	5.06"A x 5.06"B	0.218	Figure 12
MDP0403E	256	15	15"H x 9.1"W x 12"D	14.25"A x 4.5"B	0.218	Figure 15
	256	15	15"H x 9.1"W x 12"D	14.25"A x 4.5"B	0.218	Figure 15
	257	15	15"H x 9.1"W x 12"D	14.25"A x 4.5"B	0.218	Figure 15
MDP0482E	256	15	15"H x 9.1"W x 12"D	14.25"A x 4.5"B	0.218	Figure 15
	256	15	15"H x 9.1"W x 12"D	14.25"A x 4.5"B	0.218	Figure 15
	258	11.25	12"H x 9.1"W x 12"D	11.25"A x 4.5"B	0.218	Figure 14
	259	11.25	12"H x 9.1"W x 12"D	11.25"A x 4.5"B	0.218	Figure 14
MDP0636E	252	15	15"H x 9.1"W x 12"D	14.25"A x 4.5"B	0.218	Figure 15
	252	15	15"H x 9.1"W x 12"D	14.25"A x 4.5"B	0.218	Figure 15
	252	15	15"H x 9.1"W x 12"D	14.25"A x 4.5"B	0.218	Figure 15
	252	15	15"H x 9.1"W x 12"D	14.25"A x 4.5"B	0.218	Figure 15
	246	7.5	8"H x 9.1"W x 12"D	7.25"A x 4.5"B	0.218	Figure 13
MDP0786E	260	15	15"H x 9.1"W x 12"D	14.25"A x 4.5"B	0.218	Figure 15
	260	15	15"H x 9.1"W x 12"D	14.25"A x 4.5"B	0.218	Figure 15
	260	15	15"H x 9.1"W x 12"D	14.25"A x 4.5"B	0.218	Figure 15
	261	15	15"H x 9.1"W x 12"D	14.25"A x 4.5"B	0.218	Figure 15
	261	15	15"H x 9.1"W x 12"D	14.25"A x 4.5"B	0.218	Figure 15
	262	7.5	8"H x 9.1"W x 12"D	7.25"A x 4.5"B	0.218	Figure 13

Note: Units above 128 amps require multiple parallel cap panels
Use the above table and referenced figures to establish suitable Cap-panel mounting

HMR MOUNTING & TERMINAL LOCATIONS

HMR 6 - 11 Amps

**Filters No Longer Ship
 With Resistors**

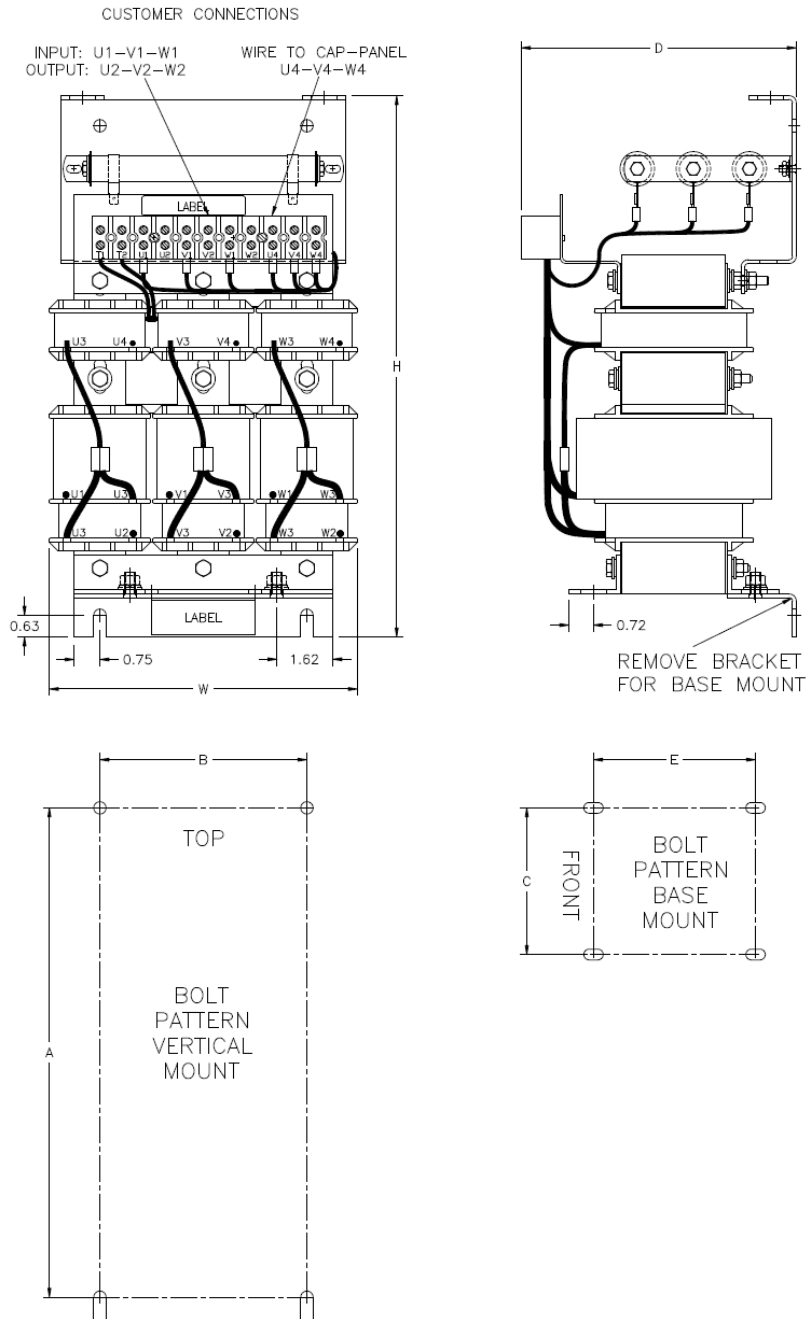

Figure 5 6 - 11 AMP

HMR MOUNTING & TERMINAL LOCATIONS

HMR 14 -34 Amp

**Filters No Longer Ship
 With Resistors**

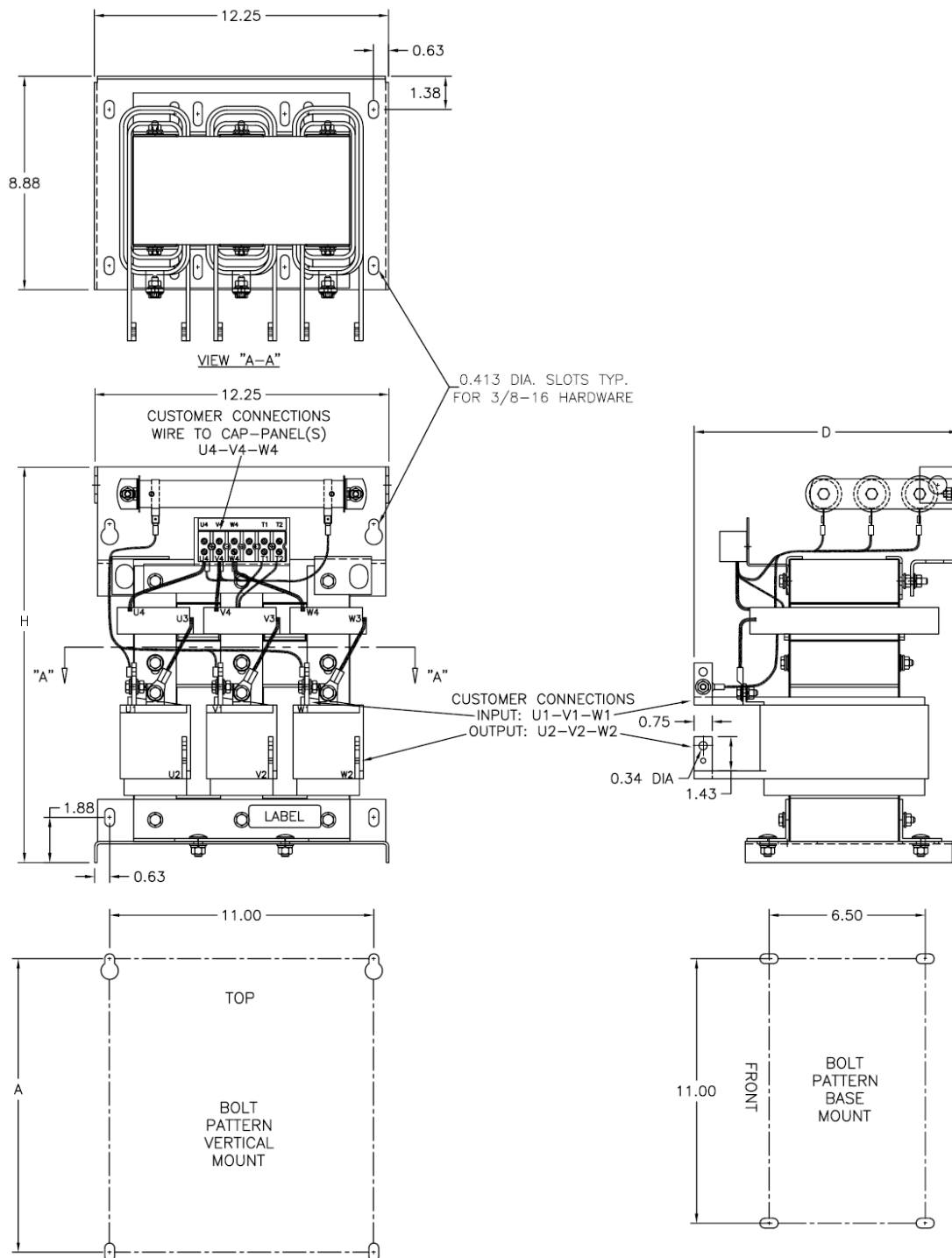

Figure 6 14 - 34 AMP

HMR MOUNTING & TERMINAL LOCATIONS

HMR 44 - 83 Amp

**Filters No Longer Ship
 With Resistors**

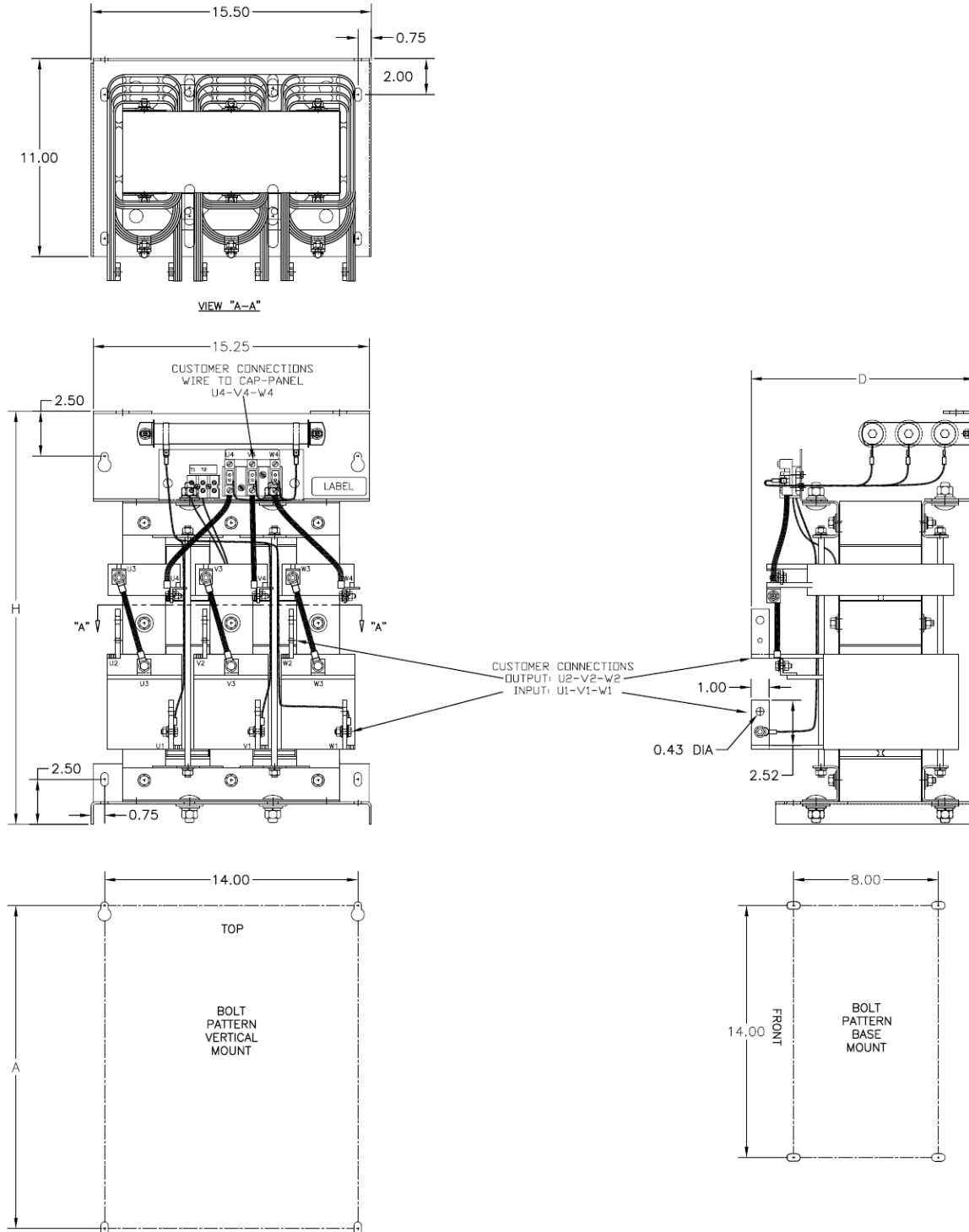

Figure 7 44 – 83 AMP

HMR MOUNTING & TERMINAL LOCATIONS

HMR 103 - 208 Amp

**Filters No Longer Ship
 With Resistors**

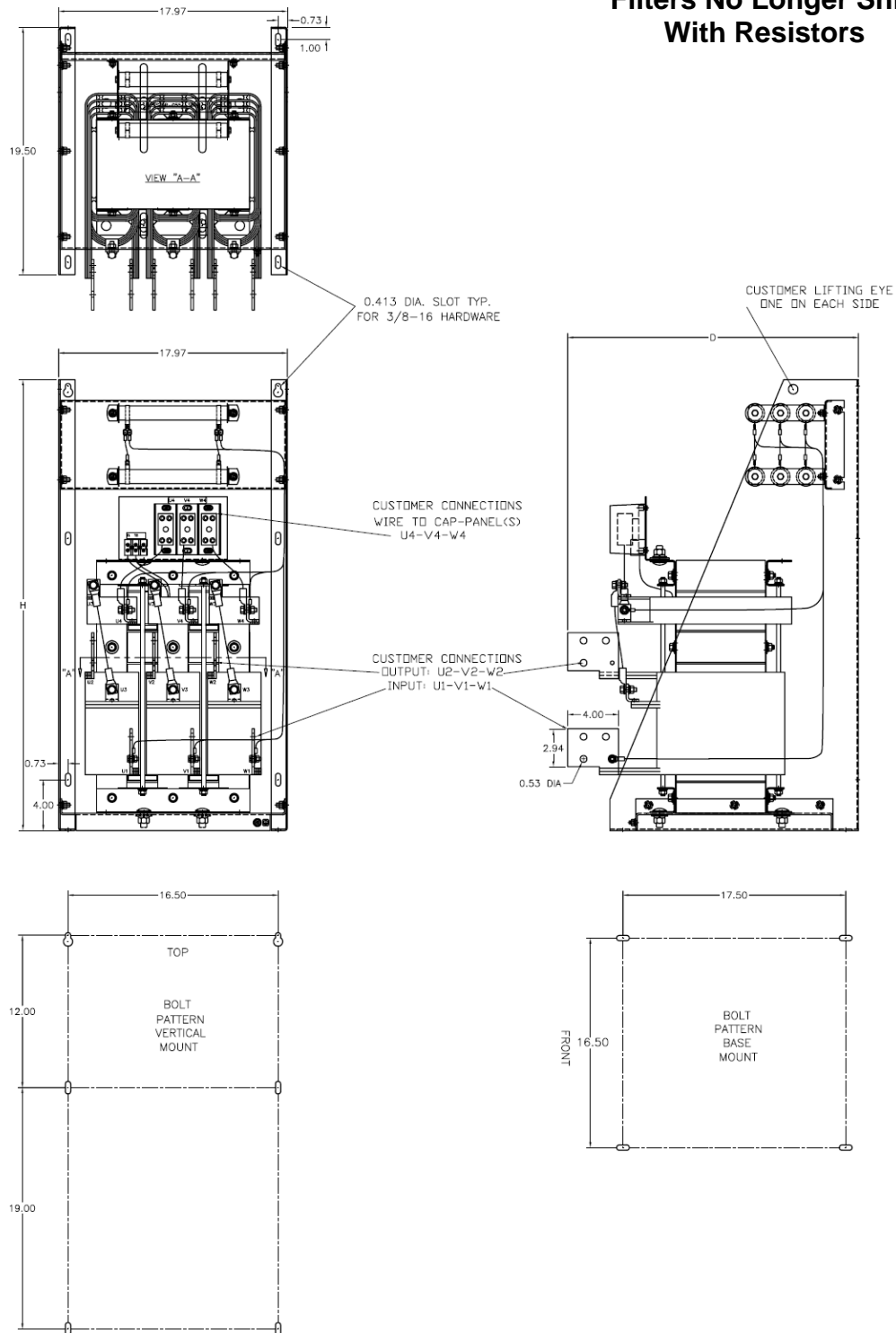

Figure 8 103 – 208 AMP

HMR MOUNTING & TERMINAL LOCATIONS

HMR 240 - 786 Amp

**Filters No Longer Ship
 With Resistors**

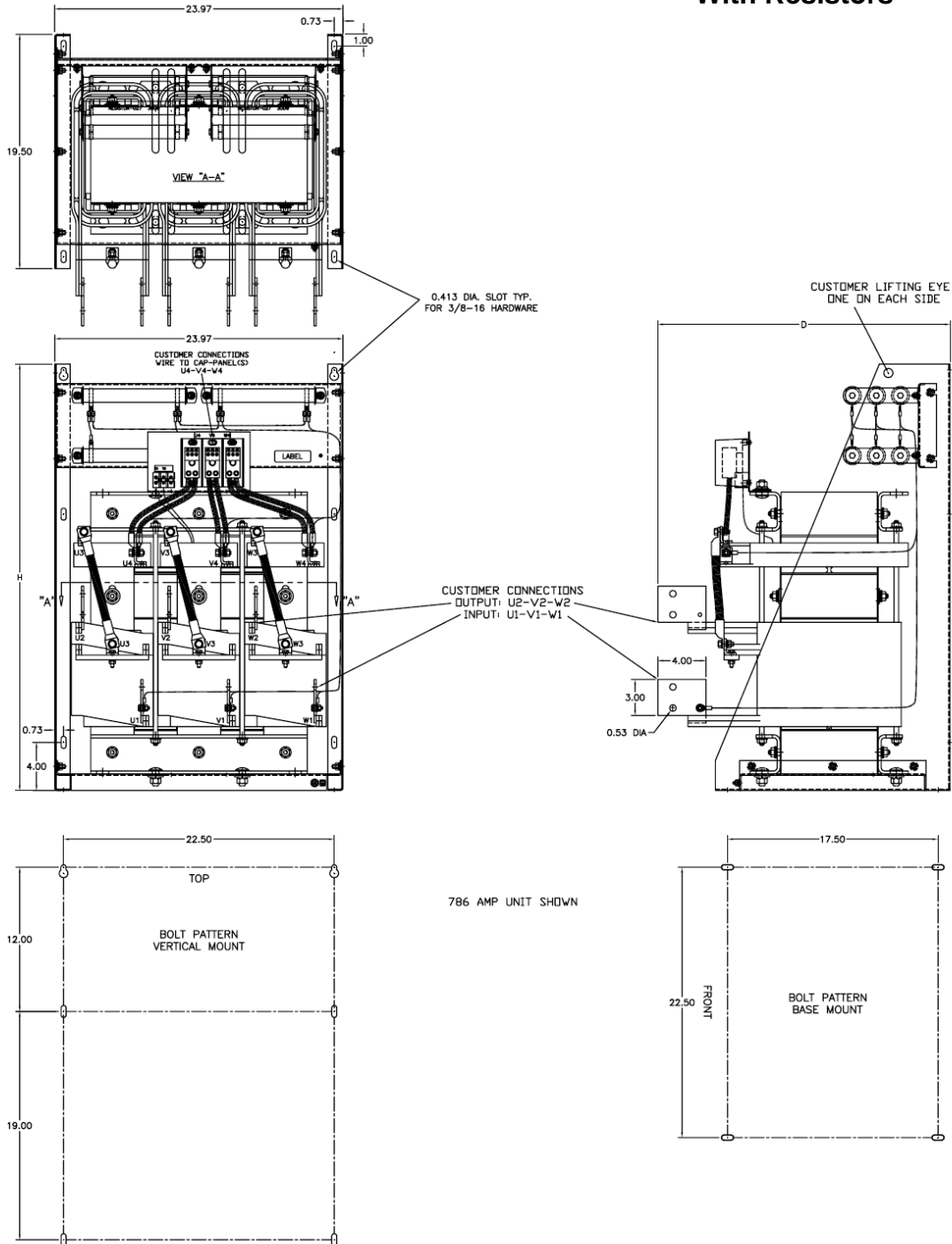
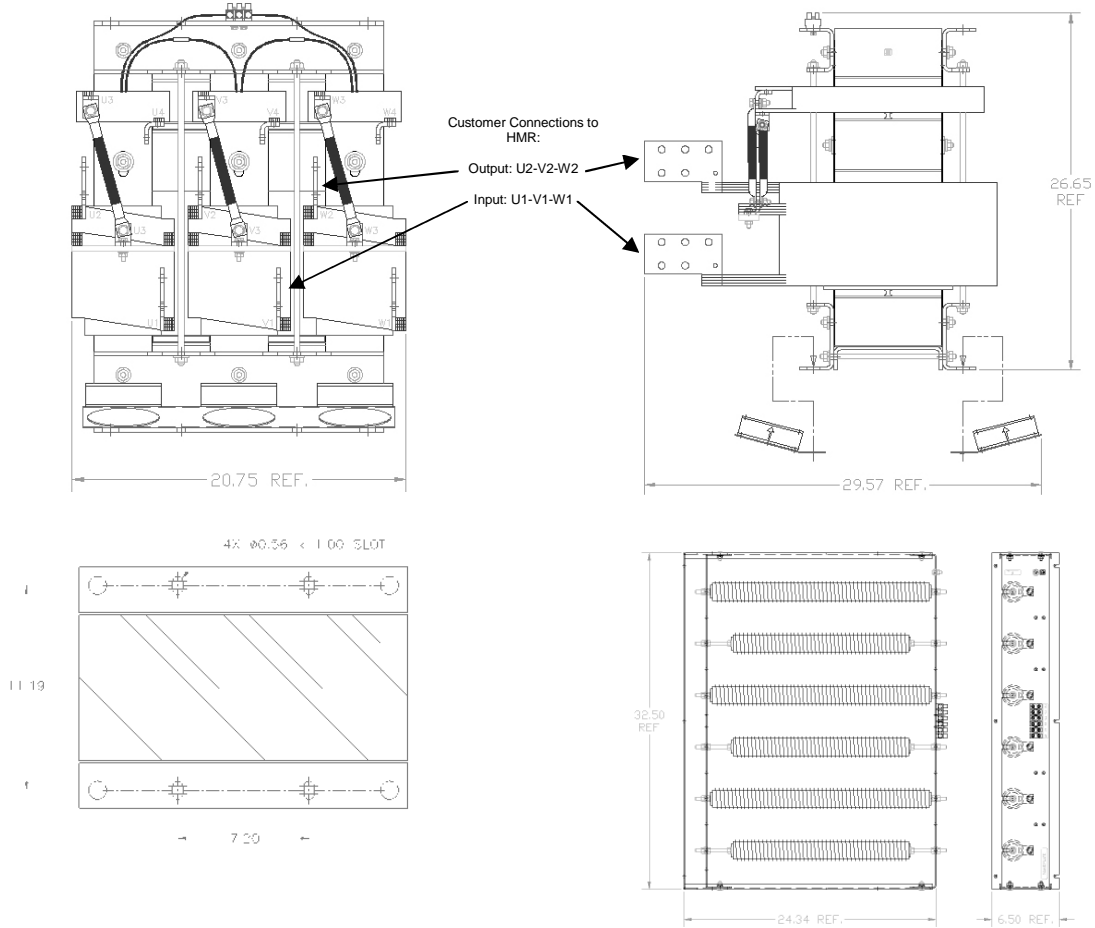

Figure 9 240 – 786 AMP

HMR MOUNTING & TERMINAL LOCATIONS

HMR 850 - 1200 Amp



**Filters No Longer Ship
 With Resistors**

Figure 10 850 – 1200 AMP

CAP-ASSEMBLY MOUNTING & TERMINAL LOCATIONS

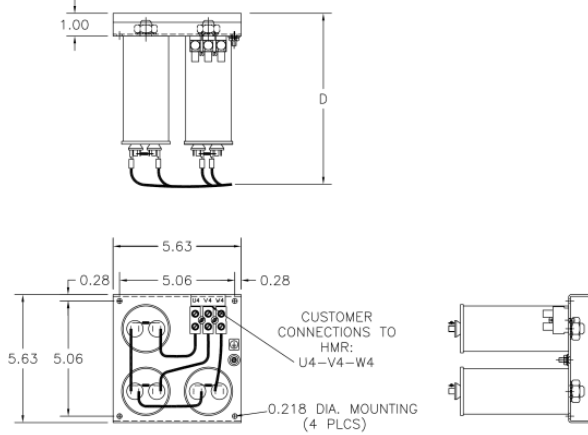

Figure 12 3 Caps

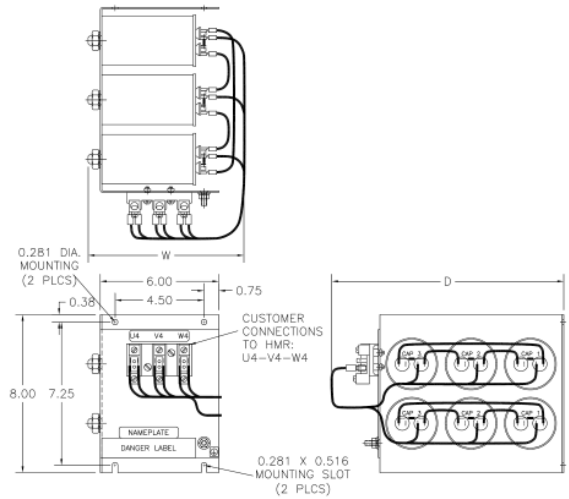

Figure 13 6 Caps

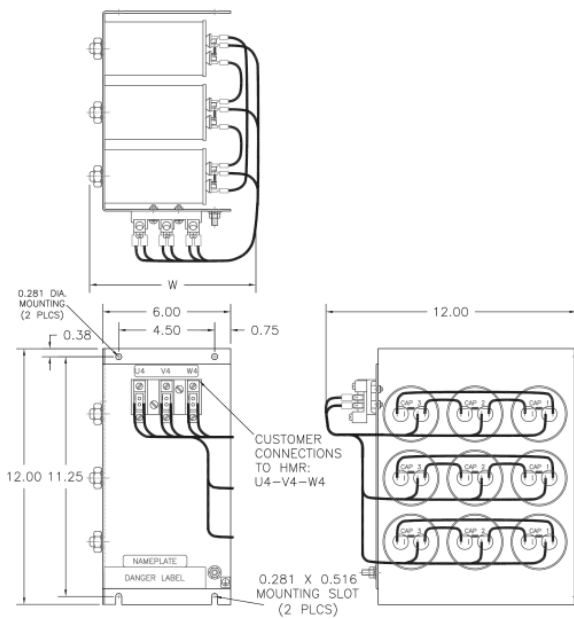

Figure 14 9 Caps

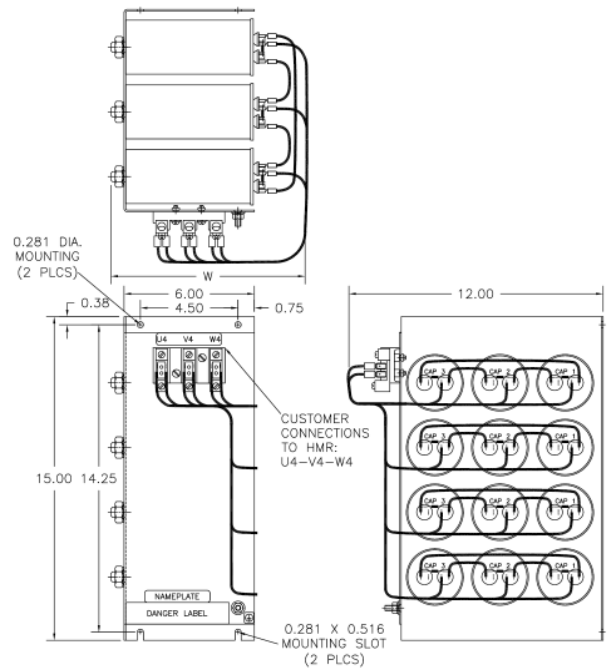

Figure 15 12 Caps

CAP-ASSEMBLY MOUNTING & TERMINAL LOCATIONS, CONT.

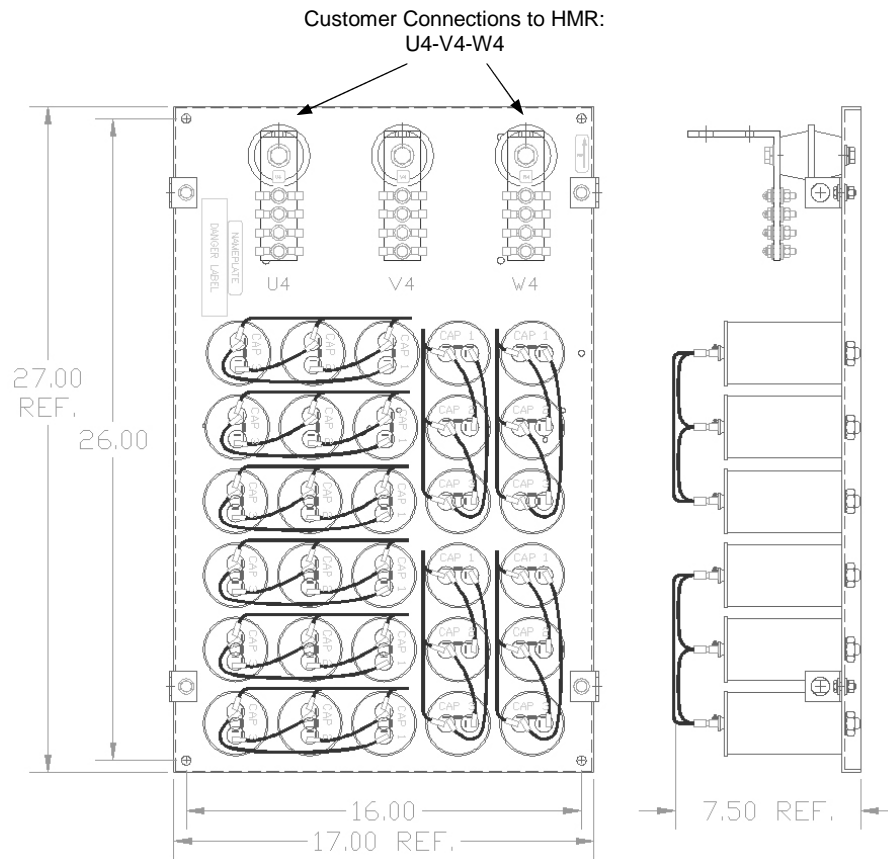
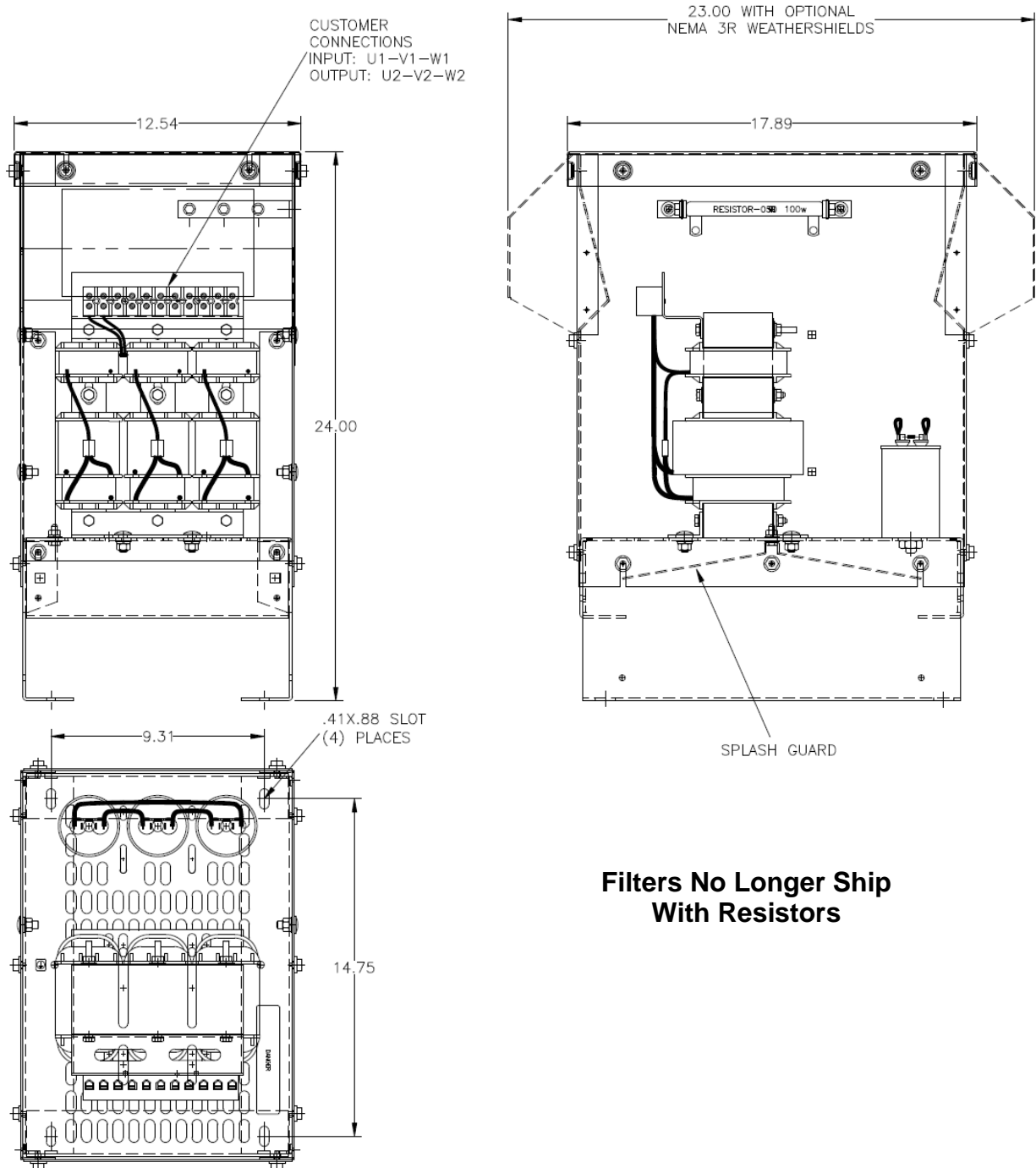

Figure 16 Up to 30 Caps

Note: Number of capacitors will vary depending on the size of the filter.

ENCLOSED UNIT INTERNAL DETAILS & TERMINAL LOCATIONS

CAB-12C 6-34 AMPS



**Filters No Longer Ship
 With Resistors**

Figure 17 6 - 34 AMP

Refer to the MTE website, www.mtecorp.com, for Detailed Specifications
 Capacitor placement shown for illustrative purposes only

ENCLOSED UNIT INTERNAL DETAILS & TERMINAL LOCATIONS

CAB-17C 44-66 AMPS

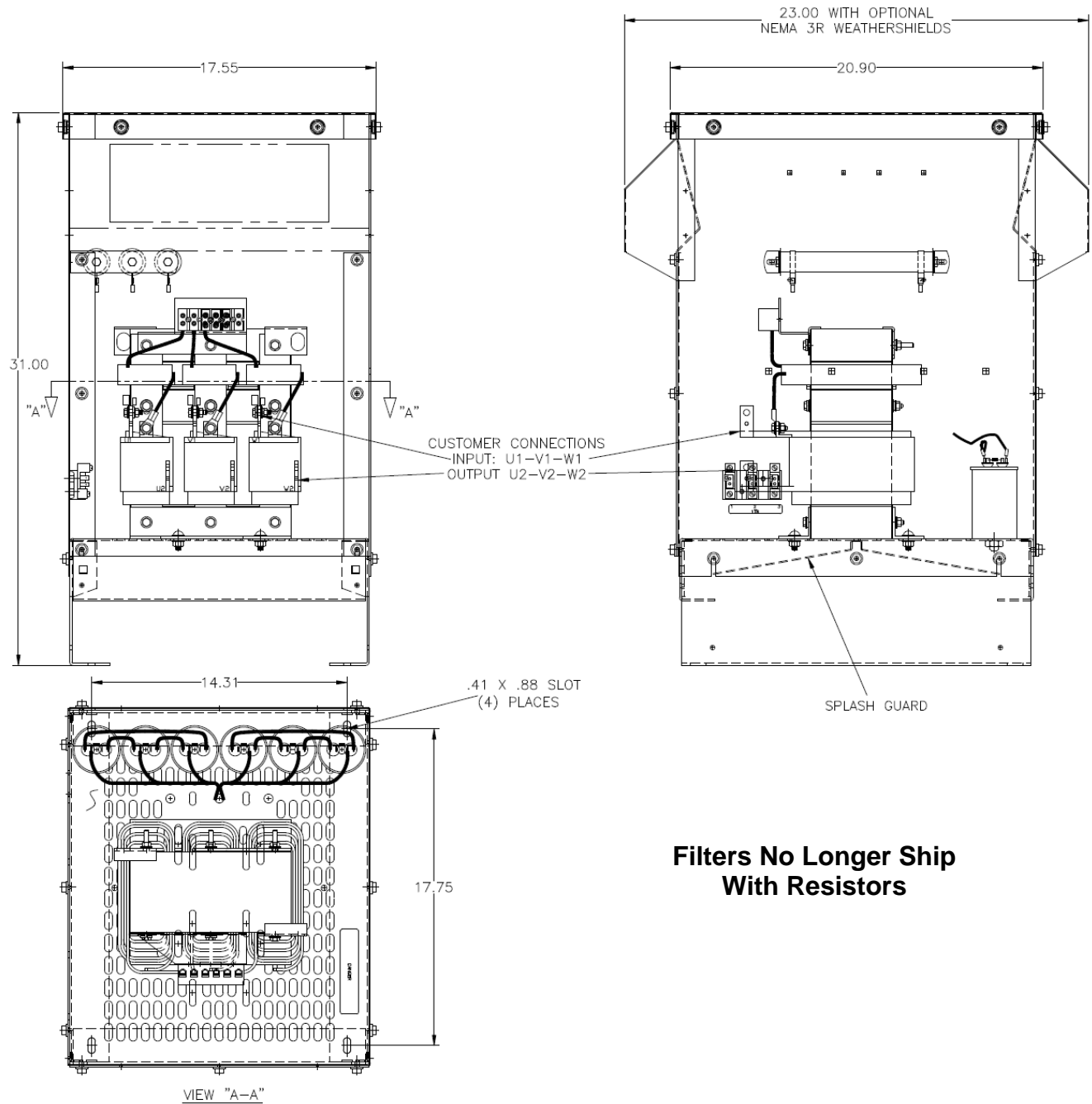

Figure 18 44-66 AMP

Refer to the MTE website, www.mtecorp.com, for Detailed Specifications
 Capacitor placement shown for illustrative purposes only

ENCLOSED UNIT INTERNAL DETAILS & TERMINAL LOCATIONS

CAB-26C 83-208 AMPS

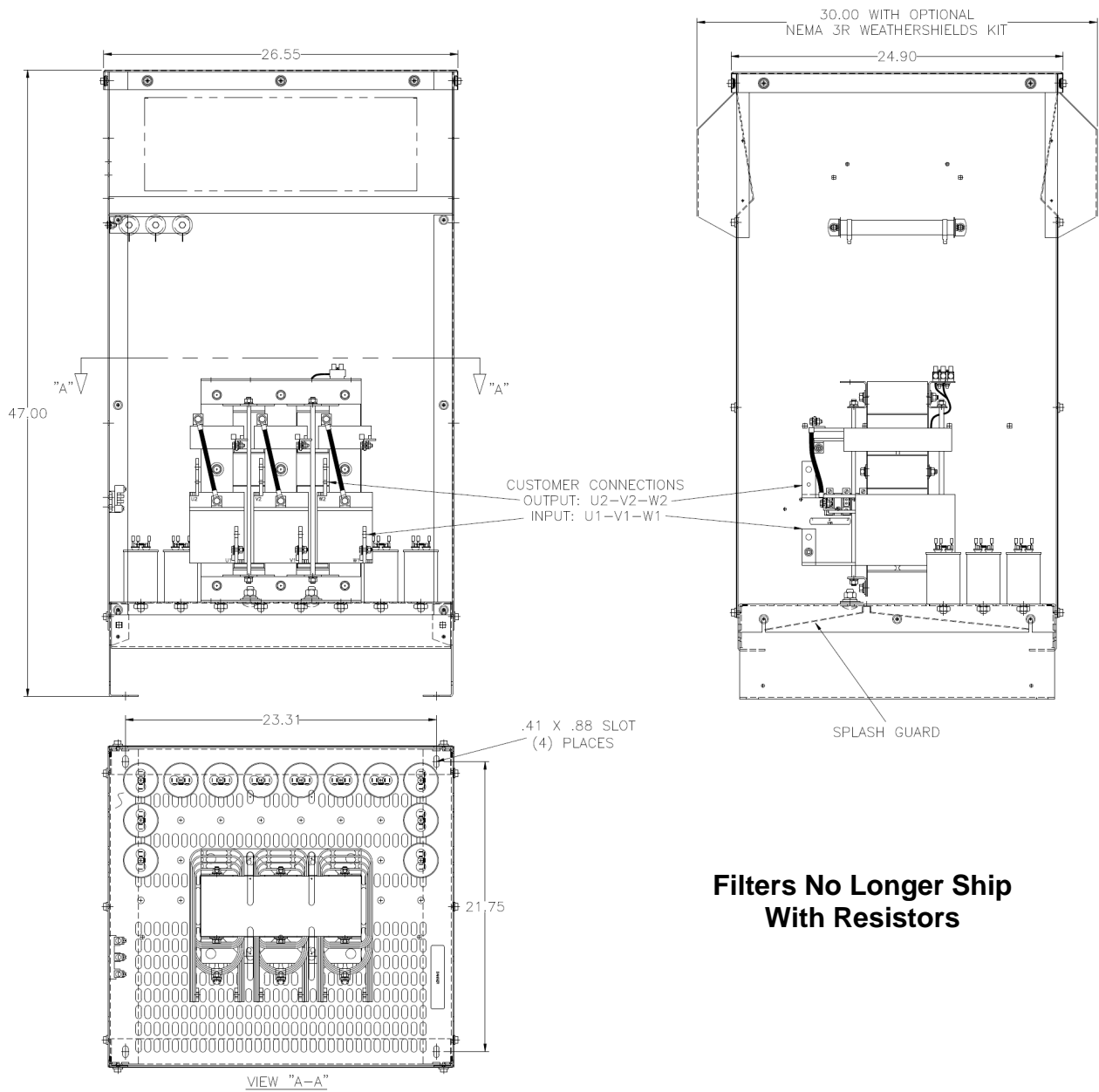
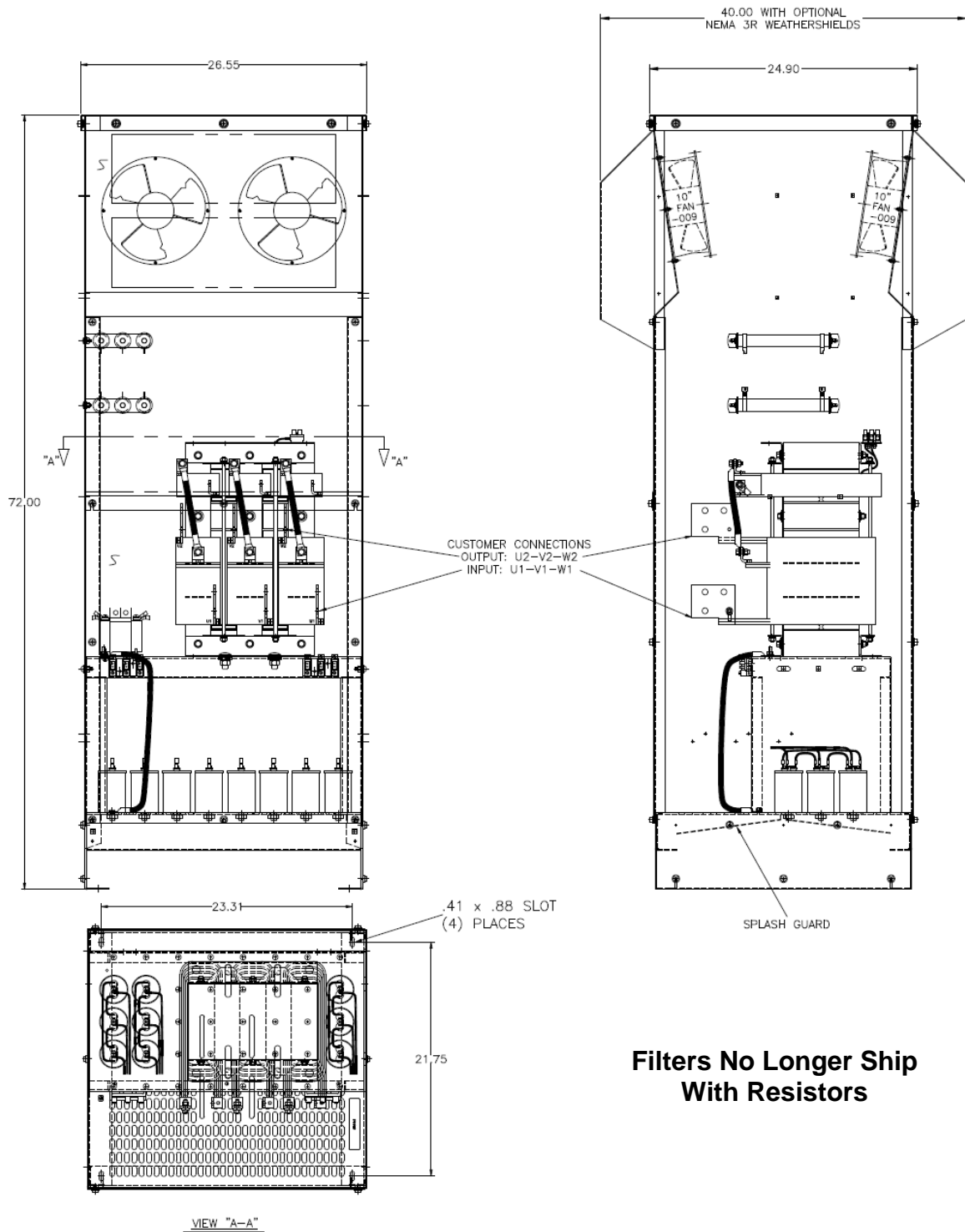

Figure 19 83-208 AMP

Refer to the MTE website, www.mtecorp.com, for Detailed Specifications
 Capacitor placement shown for illustrative purposes only

ENCLOSED UNIT INTERNAL DETAILS & TERMINAL LOCATIONS

CAB-26D 240-403 AMPS



**Filters No Longer Ship
 With Resistors**

Figure 20 240-403 AMP

Refer to the MTE website, www.mtecorp.com, for Detailed Specifications
 Capacitor placement shown for illustrative purposes only

ENCLOSED UNIT INTERNAL DETAILS & TERMINAL LOCATIONS

CAB-30D 482-636 AMPS

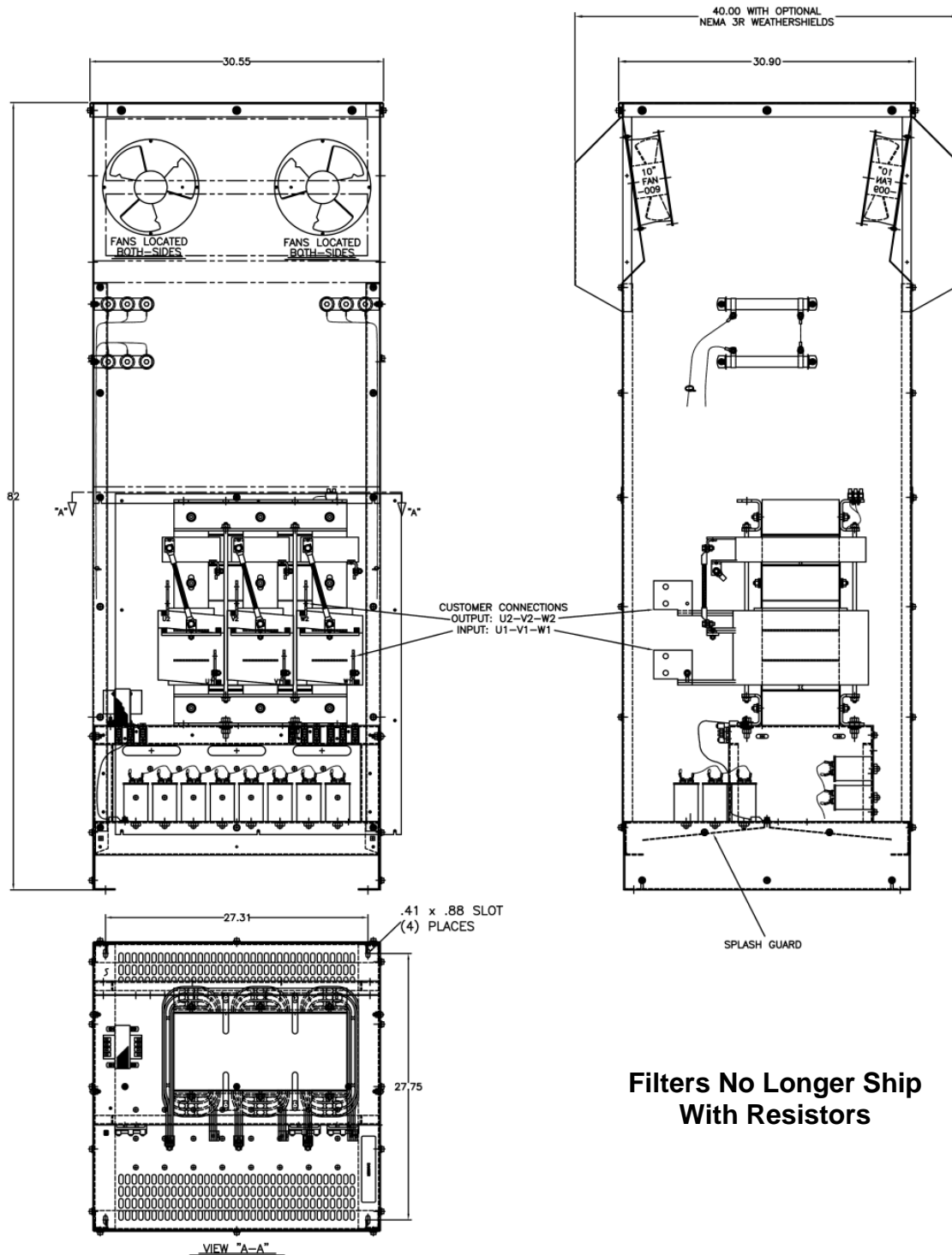

Figure 21 482-636 AMP

Refer to the MTE website, www.mtecorp.com, for Detailed Specifications
 Capacitor placement shown for illustrative purposes only

ENCLOSED UNIT INTERNAL DETAILS & TERMINAL LOCATIONS

CAB-42D 786 AMPS

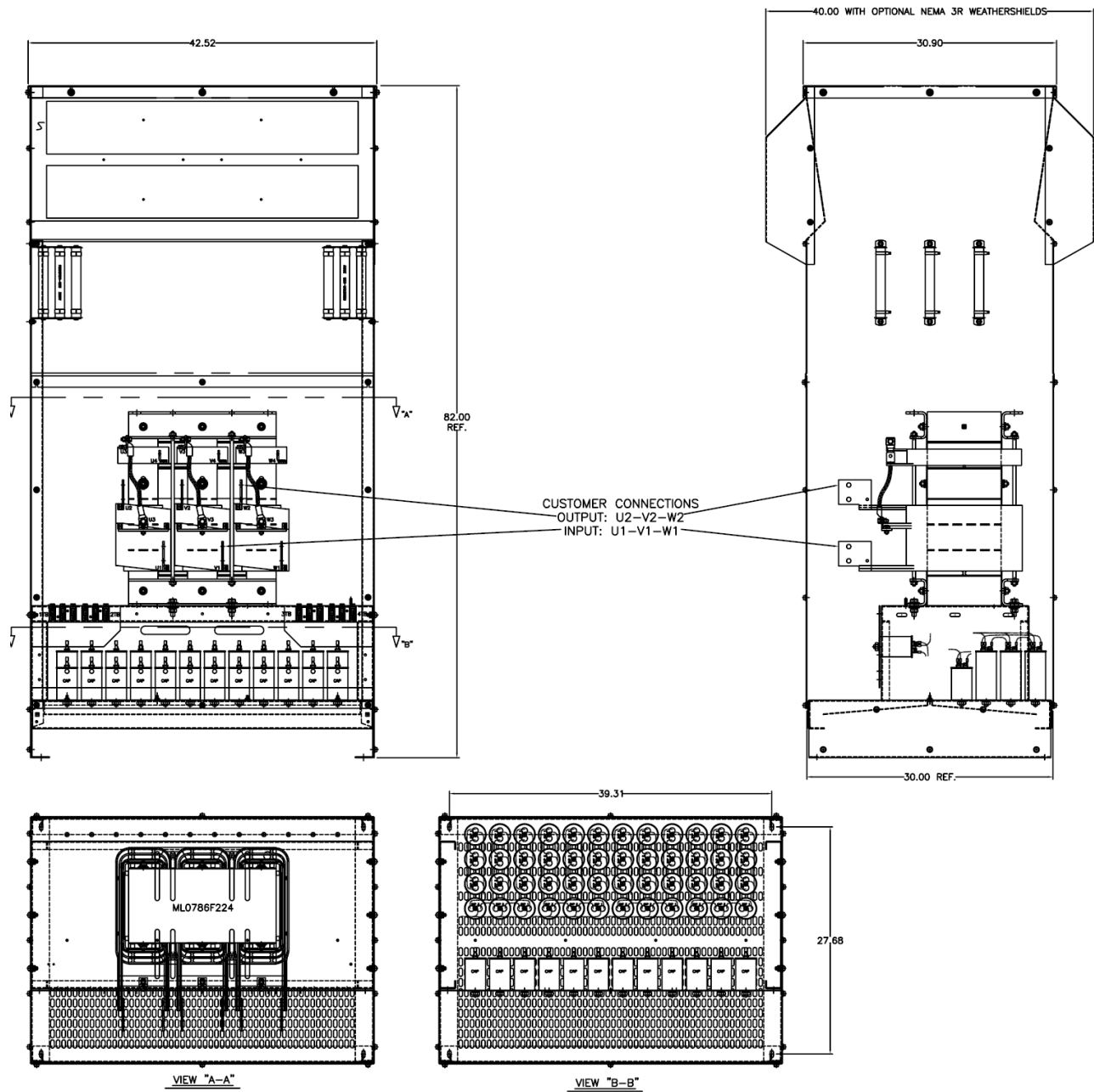

Figure 22 786 AMP

Refer to the MTE website, www.mtecorp.com, for Detailed Specifications
 Capacitor placement shown for illustrative purposes only

**Filters No Longer Ship
 With Resistors**

Power Wiring Connection



WARNING

Input and output power wiring to the filter should be performed by authorized personnel in accordance with the NEC and all local electrical codes and regulations. Cable lugs and mounting hardware are provided by the customer.

Verify that the power source to which the filter is to be connected is in agreement with the nameplate data on the filter. A fused disconnect switch or circuit breaker should be installed between the filter and its source of power in accordance with the requirements of the NEC and all local electrical codes and regulations. Refer to the drive user manual for selection of the correct fuse rating and class.

The filter is suitable for use on a circuit capable of delivering not more than 100K RMS symmetrical amperes at 480 volts maximum when protected by type J, T or RK1 class fuses or a circuit breaker having an interrupting rating not less than 100K RMS symmetrical amperes, 480 volts maximum.

For panel mounted filter applications interconnection between the filter, its power source the cap-panels and the drive is shown in Figure 24. Table 10 lists the wire range and terminal torque requirements as a function of filter current ratings. Use table 10 for selecting conductors that interconnect the HMR and capacitor assemblies. Filters that use multiple cap-panels share total cap current shown on table 3.

Refer to the drive user manual for instructions on interconnecting the drive and motor and the correct start-up procedures for the drive.

The filter is designed for use with copper conductors with a minimum temperature rating of 75 degrees C.

For filters supplied in general purpose NEMA, 2 & 3R cabinets, interconnection between the filter, its power source, and the drive is shown in Figure 25. Refer to Figures 5 to 10 for the location of input, output, ground, and over temperature switch terminals. Table 10 lists the wire range and terminal torque requirements as a function of filter current ratings. Refer to the drive user manual for instructions on interconnecting the drive and motor and the correct start-up procedures for the drive.

Wiring checks

Using Figure 27 visually check the wired components for wiring errors then with a multi meter check phase to phase isolation using the 100 K ohm range. The multi meter will read the parallel equivalent of the bleeder resistors after the capacitors initially charge. All phase to phase resistance values should be the same.



WARNING

Any extremely low or high resistance readings indicate a mis-wire and may result in damage to filter components if not corrected.

Check for the following faults:

- Resistors wired phase to phase
- Capacitor shorted
- Capacitor bus not connected
- Capacitor bus to chassis short
- Paralleling wiring errors

Power Wiring Connection, Cont.

Grounding and Ground Fault Protection

The filter must always be grounded with a grounding conductor connected to all ground terminals.

Due to high leakage currents associated with variable frequency drives, ground fault protective devices do not necessarily operate correctly when placed ahead of a Matrix Filter feeding a drive. When using this type of device, its function should be tested in the actual installation.

Over Temperature Switch

The temperature switch is provided to annunciate adverse filter heating. Damage to the filter or drive may be avoided by interlocking this switch to shut down the drive or illuminate a service light; see figures 24 and 25 for connection diagrams. Read the vendor drive manual for details in using interlock inputs.

Input and Output Terminal Specifications

Table 10

Filter Rating (Amps)	HMR Terminals			Cap-panel Terminals U4-V4-W4		
	Input /Output Power U1-V1-W1 / U2-V2-W2		U4-V4-W4 interconnect cappanel	CAPPANEL Part Number	Minimum Interconnect Wire Gauge (AWG)	Max Terminal Torque (in-lbs)
	Wire Range (AWG)	Terminal Torque (in-lbs)	Terminal Torque (in-lbs)			
6	14 – 4	16	16	242	14	16
8	14 – 4	16	16	243	14	16
11	14 – 4	16	16	201	14	16
14	14 – 4	16	16	202	14	16
21	14 – 4	16	16	244	14	16
27	14 – 4	16	16	204	14	16
34	14 – 4	16	16	205	14	16
44	14 – 4	16	16	245	12	35
52	Flat copper tab	N/A	16	246	12	35
66	Flat copper tab	N/A	16	247	10	35
83	Flat copper tab	N/A	16	248	8	40
103	Flat copper tab	N/A	16	249	8	40
128	Flat copper tab	N/A	16	250	8	40
165	Flat copper tab	N/A	35	250	6	45
				251	14	16
208	Flat copper tab	N/A	16	252	6	45
				253	10	35
240	Flat copper tab	N/A	35	252	6	40
				254	8	40
320	Flat copper tab	N/A	35	252	6	45
				252	6	45
			20	255	14	16
				403	Flat copper tab	N/A
256	8	40				
			35	257	6	45
				482	Flat copper tab	N/A
256	8	40				
			25	258	8	40
				259	6	45
			35	252	6	45
				252	6	45
636	Flat copper tab	N/A	35	252	6	45
				252	6	45
			20	246	10	35
				786	Flat copper tab	N/A
260	4	45				
			25	260	4	45
				261	8	40
			20	261	8	40
				262	12	35

Note: Cappanel interconnect wiring specification according to UL508 75° C Table.
Note: To prevent flexing or bending of the coil windings attached to MHR Flat copper terminal tabs, use two wrenches to tighten customer provided cable mounting hardware.

Open Panel Unit Interconnection Diagram

Figure 24

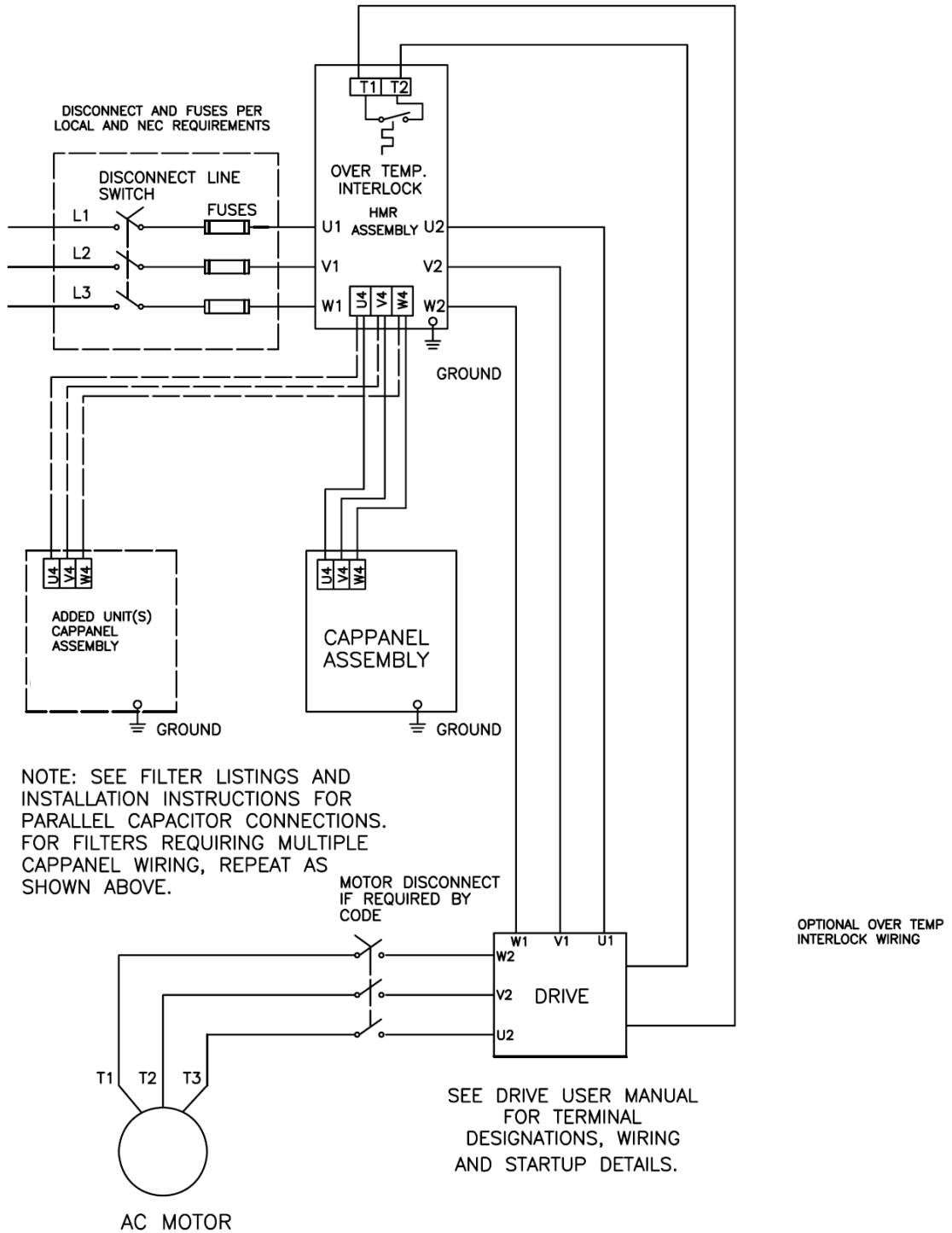

Enclosed Unit interconnection Diagram

Figure 25

Matrix Filter Series D

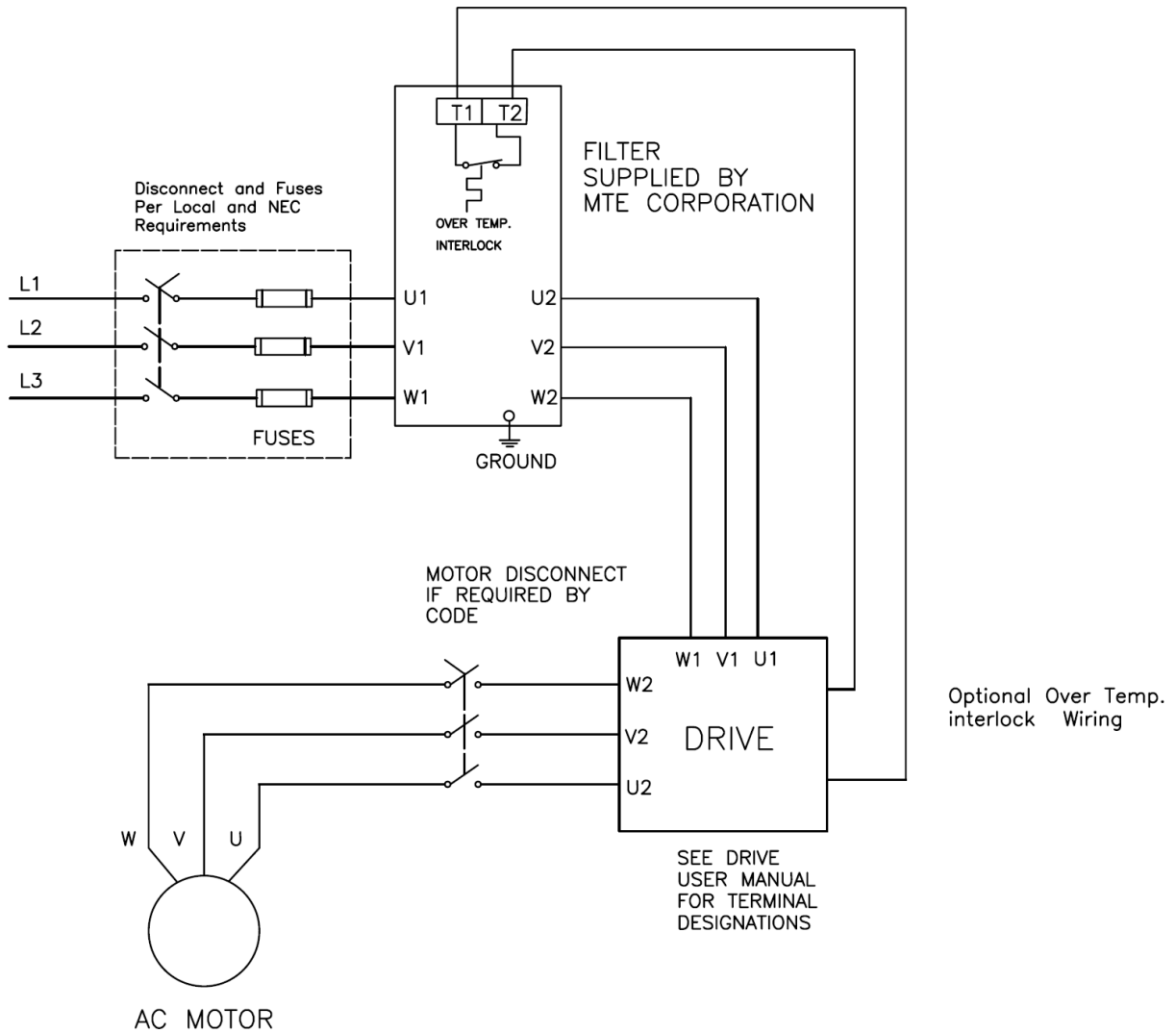

FILTER DESCRIPTION

The MTE Matrix Filter is a low pass filter containing proprietary technology, which makes it particularly useful for harmonic mitigation of adjustable speed drives. Figure 26 shows a block diagram of the filter. Three phase AC power is connected to the Harmonic Mitigating reactor HMR section which contains patented circuitry which inhibits oscillation of the filter with the AC power system. Shunt resistors and capacitor panels make up the rest of the filter. Because of the capacitor bank the filter operates with leading power factor at light loads, but unlike trap filters the MTE Matrix Filter does not produce significant voltage rise at the point of common coupling with the power system.

Matrix Filters are suitable for use with AC and DC drives and they can be used in both regenerative and non-regenerative applications when properly selected. For AC regenerative drives application consult the factory.

Filters for variable torque AC drives rated 7.5 HP and above should be selected for a filter output current rating greater than or equal to the motor current rating. If the motor current rating is not available, use the NEC motor current rating.

Filters for variable torque AC drives rated 2 – 5 HP should be selected for a filter output current rating greater than or equal to 105% of the motor current rating. If the motor current rating is not available, select on the basis of 105% of the NEC motor current rating.

Filters for variable torque AC drives rated less than 1.5 HP should be selected for an output current rating greater than or equal to 110% of the motor current rating or 110% OF the NEC motor current rating.

For constant torque, AC and DC drive applications operating from six pulse rectifier front ends selected a filter current rating according to application engineering note "Matrix Filter Operation in Constant Torque Applications with Six Pulse Rectifiers" or consult MTE engineering. For phase controlled DC drive applications, select filter current rating per application note "Matrix Filter with Phase Controlled DC Drivers."

Where a single filter is used to feed multiple drives, the output current rating of the filter should be selected to equal the total current rating of the individual drives when calculated according to the instructions above.

Because the filter supplies harmonic currents required by the drive, linear loads (such as space heaters, incandescent lighting and AC motors operated across the line) should not be connected to the output of the filter.

Block Diagram

Figure 26

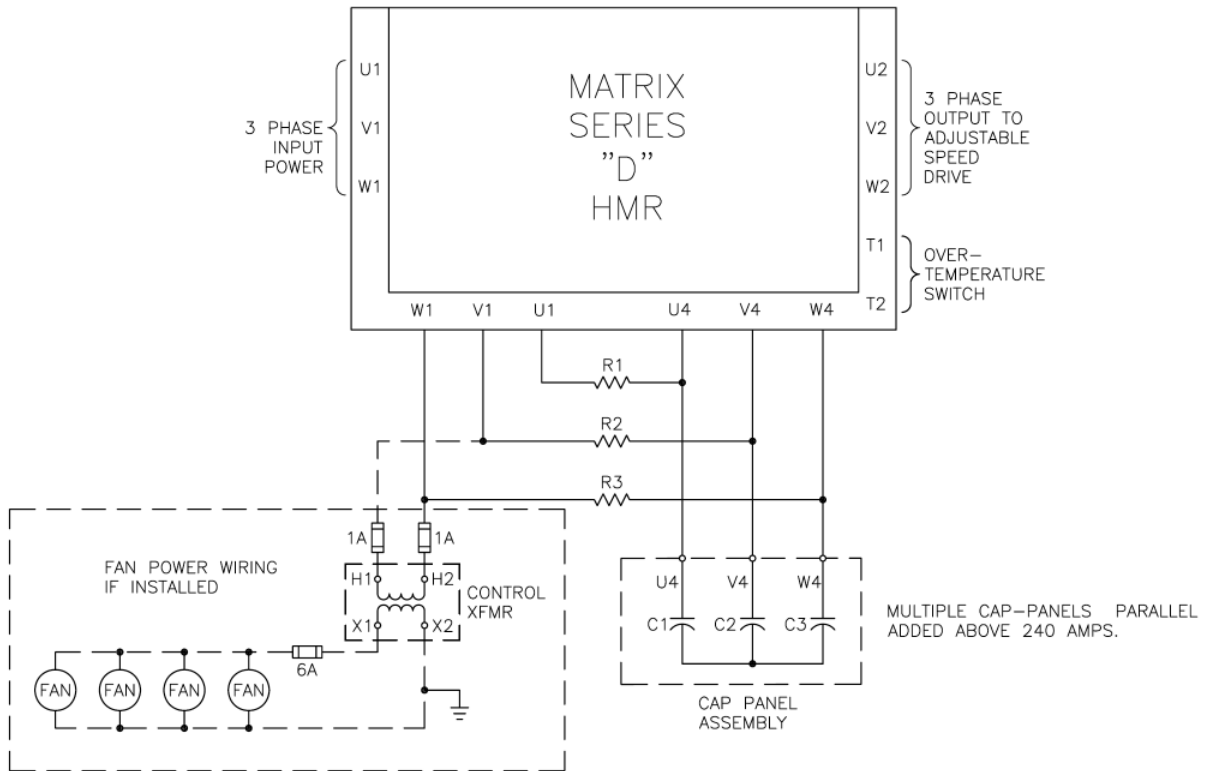

Note: Fuse sizes will vary depending on size of filter.

Matrix D Basic Schematic Diagram

Figure 27

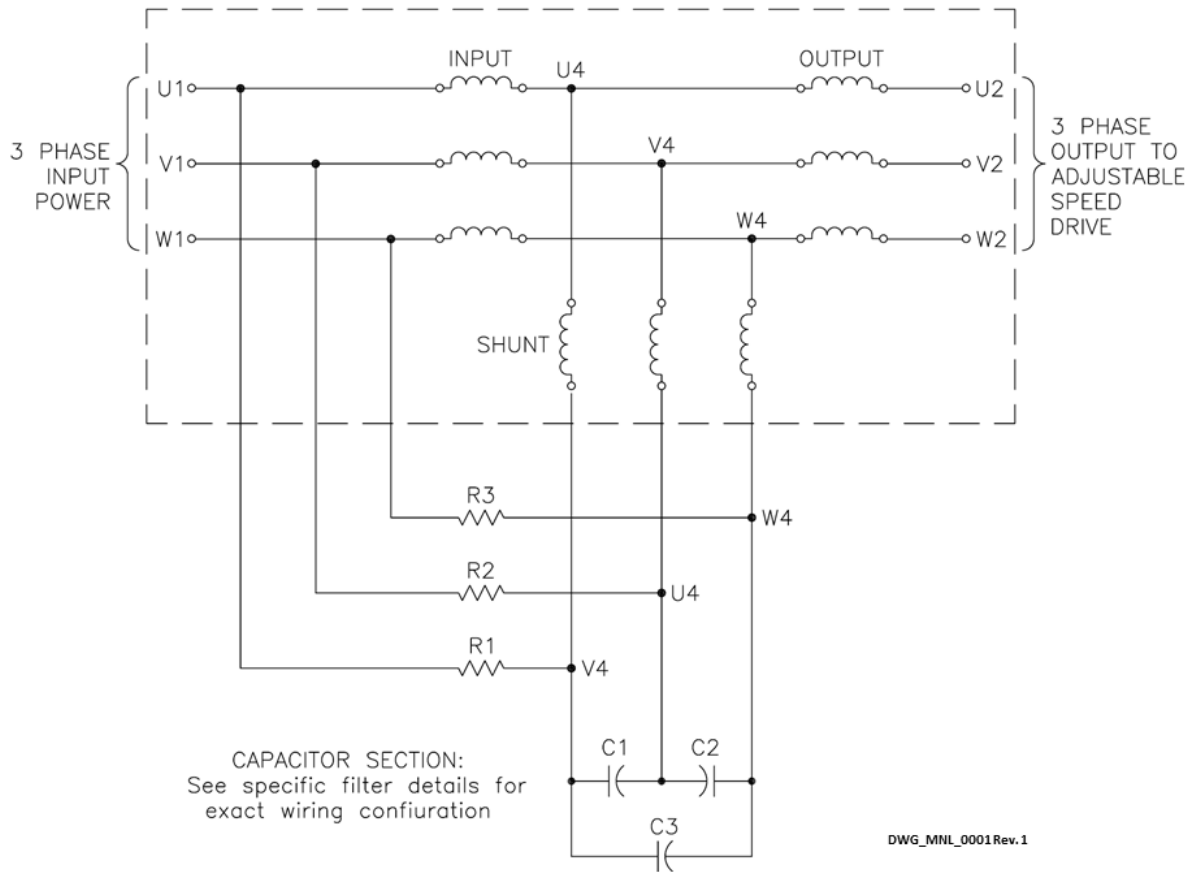

Contactor Options
 Option -002
 Capacitor Contactor

This option provides a contactor to disconnect the filter capacitor bank when the drive is not running. The contactor is supplied with NO/NC auxiliary contacts. The contactor coil and auxiliary contacts are wired to a customer terminal block. See page 48 for contactor coil switching characteristics. This option is provided pre-wired complete for enclosed filters and as loose parts for open panel filters.

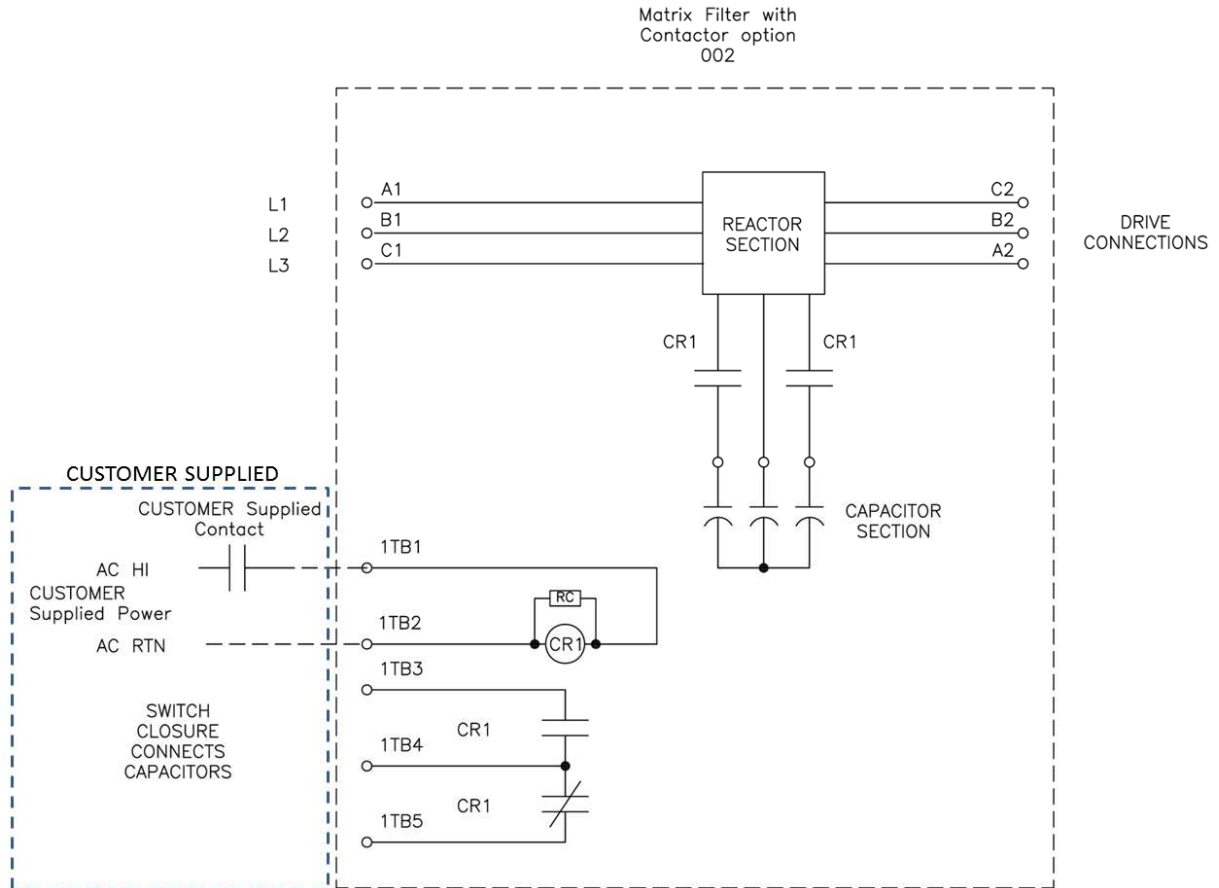

DWG_MNL_0002 Rev. 1

The above contactor option diagram is provided to help understand the circuit function and does not reflect actual circuit wiring.

Option -009
 Capacitor Contactor with adjustable pick up and drop out

This option provides a contactor to disconnect the filter capacitor bank based on the motor load current. Two current operated switches provide independent adjustment of the pick-up and drop current levels. The switches are preset at the factory for pick up at 35% and drop out at 20% of the filter output current rating. The switches are each field adjustable over a 0 – 100% current range. This option is only available for enclosed filters and except for ratings 320 – 482 amps, includes a larger cabinet to accommodate the contactor and parts associated with this option.

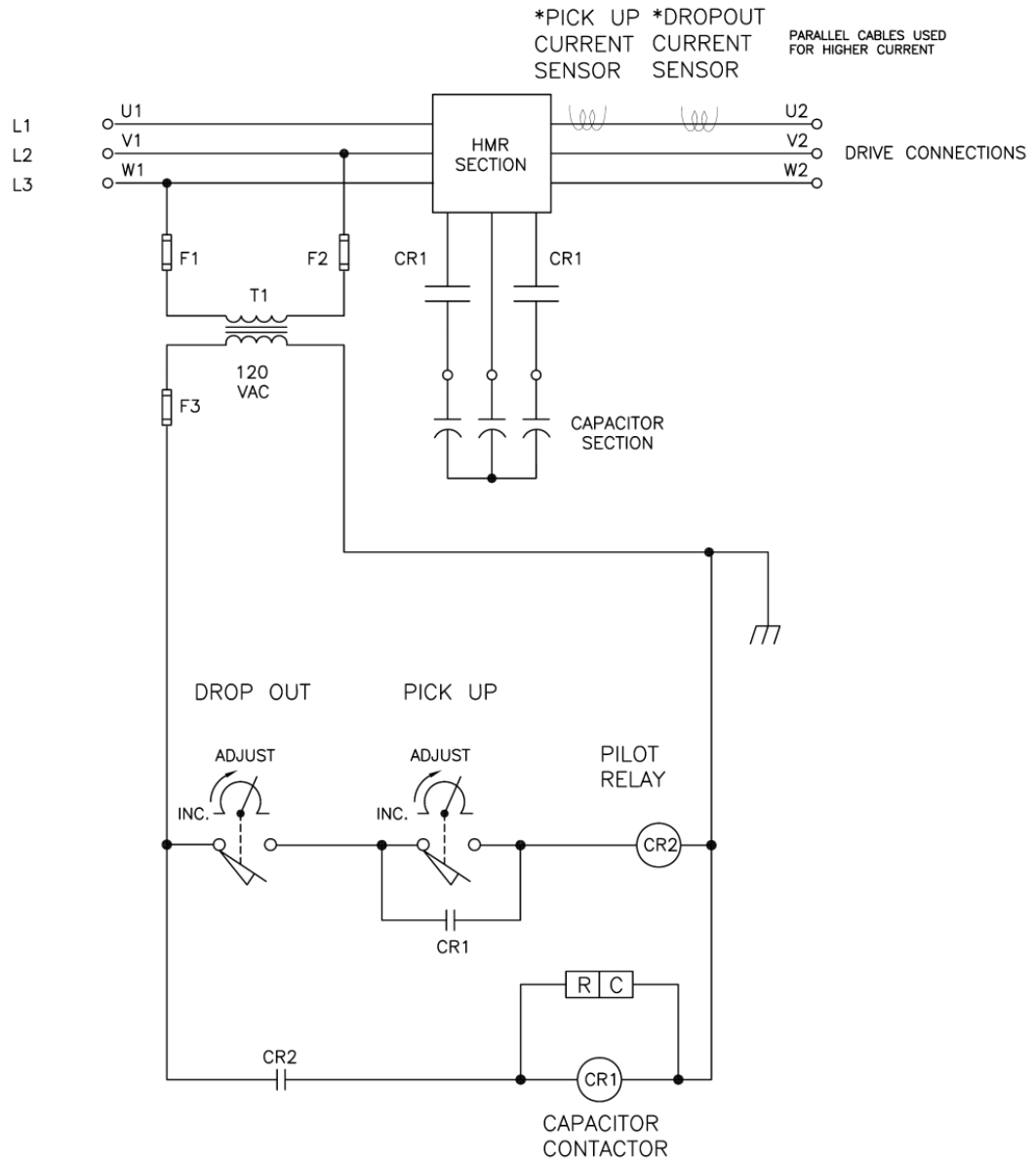

The above contactor option diagram is provided to help understand the circuit function and does not reflect actual circuit wiring.

Option -012

Capacitor contactor with control transformer

This option provides a control transformer to power the capacitor contactor. The contractor is provided with NO/NC auxiliary contacts. For filter ratings 165 amps and above a pilot relay is also provided to limit inrush current below 0.60 amps. Connections are wired to a customer terminal block. This option is only available for enclosed filters and except for ratings 320 – 482 amps, includes a larger cabinet to accommodate the contactor and parts associated with this option.

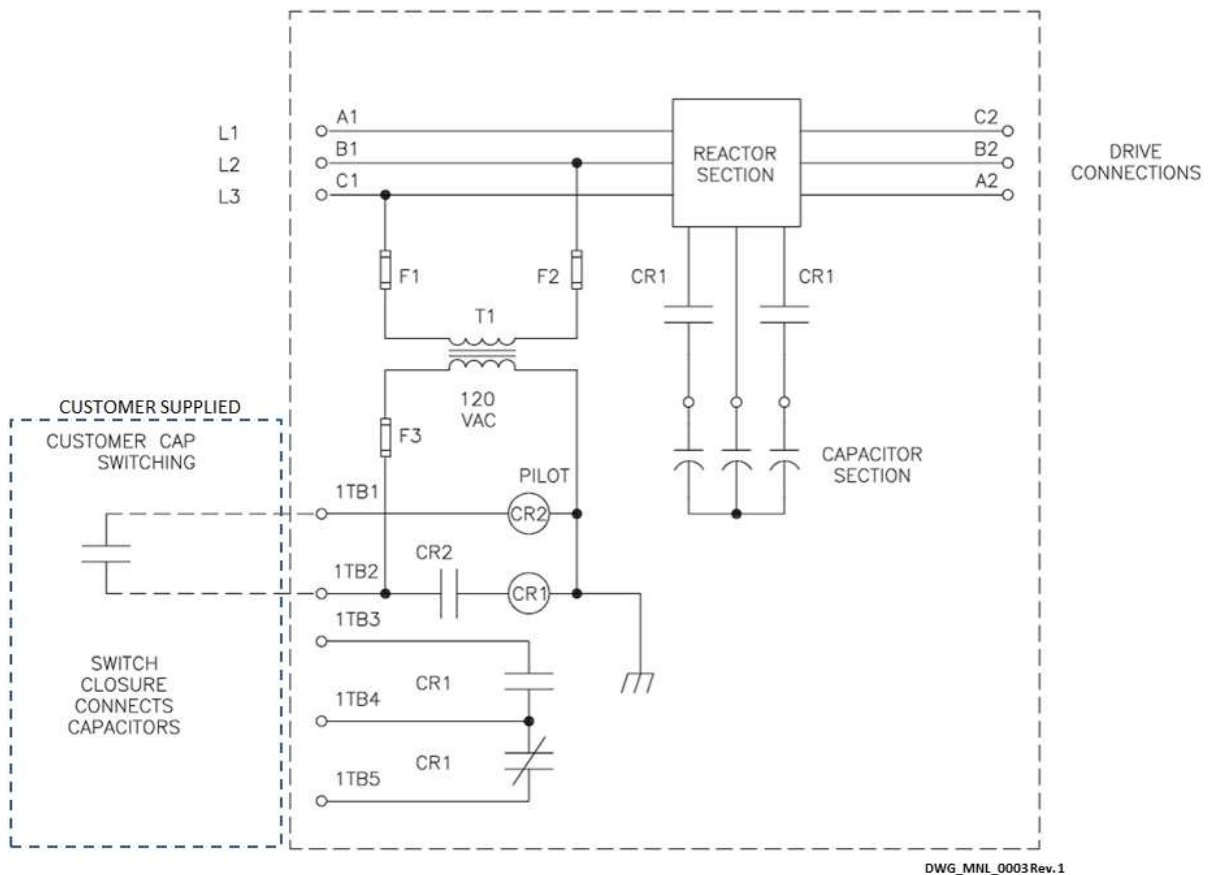

The above contactor option diagram is provided to help understand the circuit function and does not reflect actual circuit wiring.

Option -010

Filter Bypass

The filter bypass option is designed to provide filter bypass for drives that have an integrated bypass option as typically found in HVAC applications. Filter bypass is initiated by a contact closure when the motor is switched to operate directly from the AC line instead of the drive. See page 48 for contactor coil switching characteristics. A 120VAC control power source is required. This option is only available for enclosed filters and except for ratings 320 – 482 amps, includes a larger cabinet to accommodate the contactor and parts associated with this option.

Option -011

Filter Bypass with transformer

The filter bypass option is designed to provide filter bypass for drives that have an integrated bypass option as typically found in HVAC applications. Filter bypass is initiated by a contact closure when the motor is switched to operate directly from the AC line instead of the drive. A control transformer provides 120 VAC power for contactor operation. See page 48 for contactor coil switching characteristics. This option is only available for enclosed filters and except for ratings 320 – 482 amps, includes a larger cabinet to accommodate the contactor and parts associated with this option.

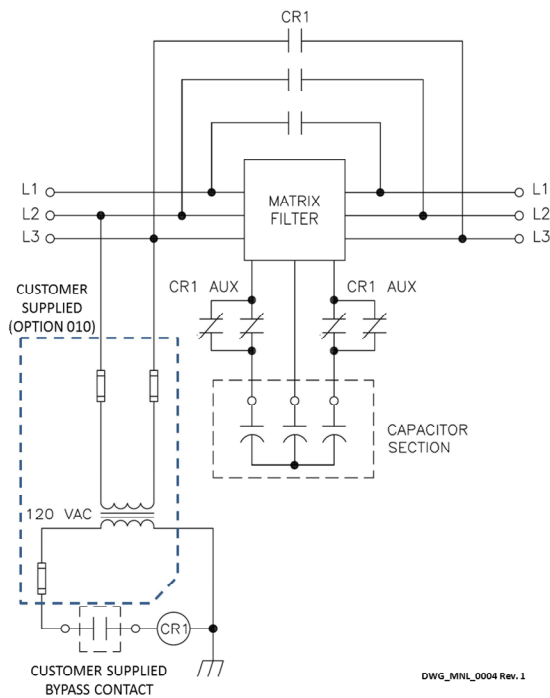

Filters rated 44 Amps and below

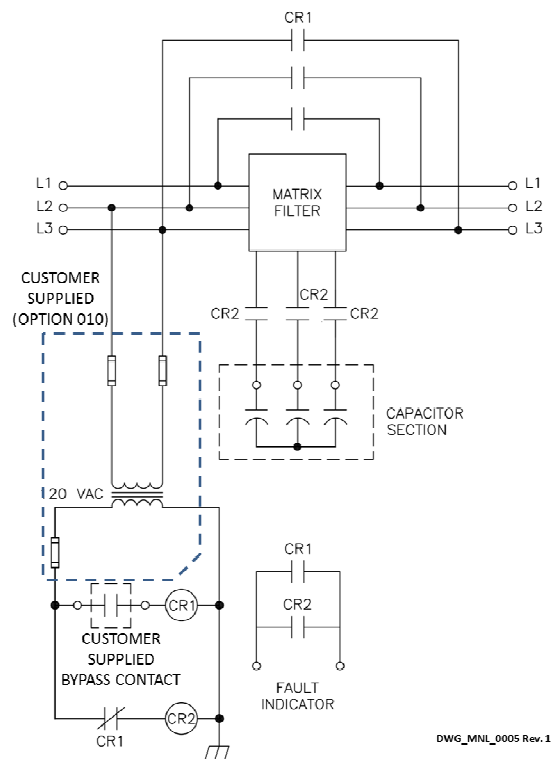

Filters rated 55 Amps and above

The above contactor option diagram is provided to help understand the circuit function and does not reflect actual circuit wiring.

Option -013

Filter bypass and capacitor contactor with control transformer

This option provides a 120 VAC control transformer to power the capacitor and bypass contactors. Contactors are provided with NO/NC auxiliary contacts. For filter ratings 44 amps and above pilot relays are also provided to limit inrush currents below 0.60 amps. A jumper selection provides single contact switching for normal bypass control with capacitor removal. Connections are wired to a customer terminal block.

This option is only available for enclosed filters and except for ratings 320 – 482 amps, includes a larger cabinet to accommodate the contactor and parts associated with this option.

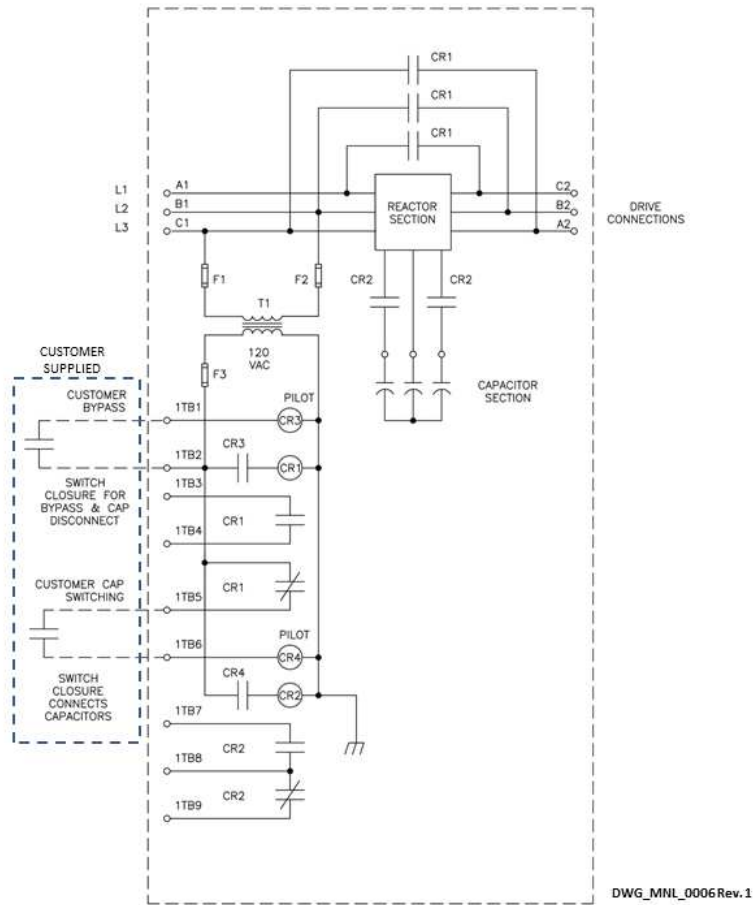

The above contactor option diagram is provided to help understand the circuit function and does not reflect actual circuit wiring.

MTE BY-PASS option 010, 011 and 013



Warning!!!

Equipment damage may result from activation of the bypass contactor during motor operation. Ensure the motor is at rest before switching the bypass control contactor!

Purpose: Provide compatible hardware to integrate a system motor bypass when used in conjunction with a drive which supports the bypass function as required for HVAC and control applications.

- 1.) To switch out the Matrix Filter and connect utility power to the Matrix output terminals to support a motor bypass initiated from the control contact of the drive.
- 2.) During the bypass mode, remove the effect of Matrix Filter capacitor loading on drive utility branch circuits

Design:

For low current Matrix Filters a single contactor CR1 provides the dual function switching to accomplish bypassing the Matrix Filter and removal of the filter's capacitors. For higher current filters a second powered contactor CR2 connects the capacitors to the filter circuit. See the schematic drawings that show these circuits.

Function description:

- 1.) (Matrix Filter mode): The bypass coil CR1 is de-energized: the Matrix Filter provides normal harmonic attenuation of the VFD distorted power. For the dual contactor systems the capacitor contactor CR2 must be powered to get maximum THID reduction.
- 2.) With 120 VAC 60 Hz on CR1 from the customer supplied contact selection:
A three phase connection is made across the Matrix Filter input to the corresponding output terminals. At the same time CR1 auxiliary contacts or the second CR2 contactor remove the capacitors from the filter circuit.

Contactor coil switching currents

Table 11

Options 002, 010 & 011

The following table indicates the 120 VAC 60 Hz current required to switch and hold the various size contactors used in Matrix Filter capacitor switching and bypass options. This data is provided to select the proper switch rating to remotely control the contactor.

Contactor Currents for 120 VAC 60 Hz coils.

Matrix filter current Rating AMPS	Capacitor Contactor Option 002 AMPS		Filter Bypass Options 010 & 011 AMPS	
	<i>INRUSH</i>	<i>SEALED</i>	<i>INRUSH</i>	<i>SEALED</i>
6	0.62	0.048	1.25	0.096
8	0.62	0.048	1.25	0.096
11	0.62	0.048	1.25	0.096
14	0.62	0.048	1.25	0.096
21	0.62	0.048	1.25	0.096
27	0.62	0.048	1.25	0.096
34	0.62	0.048	1.25	0.096
44	0.62	0.048	1.55	0.112
52	0.62	0.048	2.33	0.352
66	0.62	0.048	3.50	0.30
83	0.62	0.048	3.50	0.30
103	0.62	0.048	2.04	0.074
128	0.92	0.064	2.34	0.95
165	1.70	0.30	3.78	1.73
208	2.88	0.25	4.96	0.286
240	1.42	0.026	3.50	0.062
320	1.42	0.026	5.17	0.062
403	2.08	0.036	5.83	0.072
482	2.08	0.036	5.83	0.072
636	2.08	0.036	8.75	0.072
786	3.75	0.036	10.42	0.072

STARTUP

Safety Precautions

Before startup, observe the following warnings and instructions:



WARNING

Internal components of the filter are at line potential when the filter is connected to the utility. This voltage is extremely dangerous and may cause death or severe injury if you come in contact with it.



WARNING

After disconnecting the utility power, wait at least 5 minutes before doing any work on the filter connections. After removing power, allow at least five minutes to elapse and verify that the capacitors have discharged to a safe level before contacting internal components. Connect a DC voltmeter across the capacitor terminals. Start with the meter on the highest scale and progressively switch to a lower scale as the indicated voltage falls below the maximum value of the scale used.

Sequence of Operation

1. Read and follow safety precautions.
2. After installation, ensure that:
 - All filter ground terminals are connected to ground.
 - Power wiring to the utility, drive and motor is in accordance with the power wiring connection diagrams shown in installation instructions section. Use the guidelines of table 10 for power and cap-panel wire gauges.

3. Check that moisture has not condensed on the filter components. If moisture is present, do not proceed with startup until the moisture has been removed.
4. Disconnect the filter output from the drive.
5. Connect the filter to the utility.



WARNING

Use extreme caution to avoid contact with line voltage when checking for power. **INJURY OR DEATH MAY RESULT IF SAFETY PRECAUTIONS ARE NOT OBSERVED.**

6. Confirm that line voltage is present at the input terminals (U, V1, W1) of the filter.
7. Confirm that line voltage is present at the output terminals (U2, V2, W2) of the filter and that it is less than or equal to 1.05 times the input voltage.
8. Using a clamp on Amp meter, check input phase currents to verify they are within a 5% match to each other. Use 70% of the values from Table 3.
9. Remove power and verify that **NO VOLTAGE** is present on the filter terminals.
10. Connect the filter output to the drive.
11. Refer to the drive user manual for the drive startup procedure. Observe all safety instructions in the drive user manual.



WARNING

INJURY OR DEATH MAY RESULT IF THE DRIVE SAFETY PRECAUTIONS ARE NOT OBSERVED. DAMAGE TO EQUIPMENT MAY OCCUR IF THE DRIVE STARTUP PROCEDURES ARE NOT OBSERVED.

TROUBLESHOOTING



WARNING

When properly installed, this equipment has been designed to provide maximum safety for operating personnel. However, hazardous voltages exist within the confines of the enclosure. Servicing should therefore be performed by qualified personnel only and in accordance with OSHA Regulations.

To aid in troubleshooting, a block diagram is shown in Figure 26 and a list of potential problems and solutions are listed below.



WARNING

High voltage is used in the operation of this filter. Use Extreme caution to avoid contact with high voltage when operating, installing or repairing this filter. **INJURY OR DEATH MAY RESULT IF SAFETY PRECAUTIONS ARE NOT OBSERVED.**

After removing power, allow at least five minutes to elapse and verify that the capacitors have discharged to a safe level before contacting internal components. Connect a DC voltmeter across the capacitor terminals. Start with the meter on the highest scale and progressively switch to a lower scale as the indicated voltage falls below the maximum value of the scale used.

Troubleshooting, Cont.

MTE Matrix Filter Field Checks

1. Read and understand the voltage appropriate MTE Matrix user manual. These manuals may be downloaded from the www.mtecorp.com web site. Locate figures and drawings for your particular filter and identify the terminals locations.
2. Disconnect all power and remove input power wiring from U1, V1, W1 terminals.
3. Remove VFD drive power connections from filter terminals U2, V2, W2 and any contactor or temperature switch wiring. (For filters having control transformers: remove power fuses on top of transformer.)
4. Visually inspect filter terminals and wiring lugs for signs of heat and corrosion. **Contact factory if any wires appear to be missing or cut!**
5. Inspect the U4, V4, W4 capacitor interconnect terminals and wiring.
6. Visually inspect all capacitors for signs of case deformation bowing of the top, leaking oil or terminal damage. Note the CAP- # and date code of any damaged capacitors.
7. Using a multi meter set to read 100K ohms check:
 - a. Phase to phase U1-V1-W1-U1 (mechanically activate contactor if present) after reactor and caps charge reading should be about 40K (total equivalent breeder resistance value) and should be the same for each phase. Open circuit or very low readings indicate a problem.
 - b. Phase to chassis U1- case, V1-case, W1- case; low readings indicate a ground fault problem.
8. Ensure the "disconnect" is safe then wire the utility power to U1, V1, W1.
9. Apply power and verify that proper output voltage is present on U2, V2, and W2.
10. Using a clamp on amp meter read the filter input current:
 - a. Readings will be 0.7 of the capacitor current listed in table 3 for the listed filter current in the user manual (mechanically activate the contactor if the filter is equipped with one). Readings should be the same (+/- 5%) for all phase currents; **contact the factory if currents are out of tolerance!**
 - b. Open contactor readings will show zero current for all phases.
11. Disconnect filter power and wire the VFD to U2, V2, and W2 as well as any control wiring to the filter contactor or temperature switch. Replace any control transformer fuses. Follow the drive power startup guidelines in the drive manufactures user manual.

PROBLEM:	Line voltage is not present at the filter output terminals.
Possible cause:	Power to the filter is turned off.
Solution:	Turn power on.
Possible cause:	One or more external line fuses are blown.
Solution:	Verify the continuity of line fuses in all phases. Replace as necessary.

PROBLEM:	Full Load Harmonic current distortion exceeds 5% on one or more phases at full load.
Possible cause:	The capacitor assembly has not been connected.
Solution:	Check interconnection of capacitor assembly with HMR (Figure 19 & 20).
Possible cause:	A capacitor has failed.
Solution:	Inspect the tops of all capacitors for bowing. Replace failed capacitors.
Possible cause:	Source impedance is less than 1.5%.
Solution	Add a minimum 1.5% impedance line reactor to the filter input
Possible cause:	Input source voltage harmonic distortion.
Solution	Identify equipment causing harmonic voltage distortion and add filters as required or accept elevated THVD
Possible cause:	Line voltage unbalance exceeds 1%.
Solution:	Balance input line voltage to 1% or less.

PROBLEM:	Filter output voltage is not within specification
Possible cause:	Filter input voltage is not within specification.
Solution:	Check the AC input line voltage and verify that it is within tolerance. Refer to the filter service conditions and performance specifications for tolerances.
Possible cause:	Source impedance is out of tolerance.
Solution:	Verify that the source impedance is within tolerance. Refer to the filter service conditions and performance specifications for tolerances.
Possible cause:	One or more Capacitors is damaged
Solution:	Visually check capacitor top for distortion or doming check for shorts or open caps.
Possible cause:	Drive set up parameters do not allow for input filter
Solution:	Consult drive manufacturer to update setup to accommodate input filter
Possible cause:	Input voltage subject to extreme transients such as switching between two voltage sources. Drive faults on over or under voltage.
Solution:	Source switching is not recommended without proper phase synchronizing or allowing reasonable time delay before transfer to new source.